

**MM&D Engineering Services, Inc.**

6901 S Yosemite Street, Suite 200  
Centennial, Colorado 80112

**Phase III Drainage Study  
For  
Boondocks Entertainment Facility**

**December 21, 2014  
Revised June 3, 2015**

**Prepared For:**

**Mr. Randy Fulmer  
Select Development & Contracting, LLC  
PO Box 1030  
Meridian, Idaho 83860**

**Prepared By:**

**MM&D Engineering Services, LLC  
6901 S Yosemite St., Suite 200  
Centennial, Colorado 80112  
William E. Miller PE  
(303)-908-0062**

**JN: 12-343**

**ENGINEER'S CERTIFICATION**

The report for the final design of the Replat of Lot 4, Crown Point Filing 1, 15<sup>th</sup> Amendment was prepared by me in accordance with the provision of the Town of Parker Storm Drainage and Environmental Criteria Manual. I understand that the Town of Parker and its designated town authority do not and will not assume liability for drainage facilities designed by others.

William E. Miller PE

Registered Professional Engineer  
State of Colorado No. 13889

By: \_\_\_\_\_  
Authorized Signature

Date: \_\_\_\_\_

## TABLE OF CONTENTS

|  |       |
|--|-------|
| I Purpose  | 1     |
| II. General location and Description                   | 1-2   |
| III. Drainage basin and sub-basin                      | 2-11  |
| IV. Drainage design criteria                           | 11-13 |
| V Storm Water Management                               | 13-16 |
| VI. Conclusion   | 16    |
| Appendix A. Vicinity Map, FIRM & SCS Soils Information |       |
| Appendix B. Hydrologic calculations                    |       |
| Time Intensity Curves                                  |       |
| Time of Concentration Calc's.                          |       |
| Runoff Calculations                                    |       |
| Appendix C. Inlet Calculations                         |       |
| Appendix D. Storm Sewer Hydraulic Calculations         |       |
| Appendix E. Rip Rap Design into Rain Gardens           |       |
| Appendix F. Detention & Rain Garden Calculations       |       |
| Appendix G Emergency Overflow Calculations             |       |
| Appendix H References                                  |       |
| Appendix I Developed Map                               |       |

**Final Drainage Plan**  
**Replat of Lot 4, Crown Point, Filing 1, 15<sup>th</sup> Amendment**

**I. Purpose**

The intent of this report is to define the general runoff direction and quantities, as well as the receiving facilities of those runoff quantities, together with the locations of the water of existing water quality and detention facilities, to service the property.

**II. GENERAL LOCATION AND DESCRIPTION**

**A. Site Location**

The project is located at the southwest corner of Cottonwood Drive and E-470. The entire parcel contains 14.875 acres and access to the individual parcels are from access roads as defined in the final plat of Crown Point, F#1, 14<sup>th</sup> Amendment as recorded in the Douglas County Records at Reception No. 2007081477, October 17<sup>th</sup>, 2007. All roads with the referenced F#1 are private and are maintained by the commercial association. The re-subdivided lots within Lot 4 are mainly accessed off of a private road that skirts the west side of lot 4. A right in/right out access is proposed off of Cottonwood about midpoint of the frontage along Lot 4. The project is surrounded by E-470 on the east, Parker Road on the south, Cosco on the west, and proposed commercial property on the north. A vicinity map is included in Appendix A of this report for reference.

The entire project is located in a part of Sections 3 and 4, Township 6 South, Range 66 West of the 6<sup>th</sup> Principal Meridian, Town of Parker, County of Douglas, State of Colorado. A replat of Lot 4, Crown Point has been submitted to the Town of Parker for their review. The replat indicates that Lot 4 of F#1 is divided into 5 lots, ranging in area from 1.19 acres in lot 5 to the largest of 9.04 acres for lot 1. Boondocks Entertainment is to be constructed in Lot 1 and will consist of a 30,100 sf building with approximately 3.74 acres of outside entertainment. The outside entertainment consists of two race tracks, two miniature golf courses and a boat bumper pool.

**B. Property Description**

The property is currently owned by Stratus Companies, LLC and contains a total of 14.875 acres. The existing ground of the entire acreage slopes from the east to the west at an approximate gradient of 2%. The runoff from the property is currently collected in a drainage ditch which flows along the western property from the southwest corner of the property to the northwest corner where it is collected in a temporary water quality and sediment basin. The lot has had structural fill placed to create the slope that it now has. That structural fill has been reseeded with the native grasses that Urban Drainage has recommended for the area. The ground cover is probably at 75% and has provided protection against erosion. There do not appear to be any rivulets on the property and all the runoff appears to discharge in a sheet flow manner into the aforementioned swale.

A Custom Soil Report was prepared by NCRS for this project through their WEB program. The report identifies the soils as Bressner Sandy loam on 9.2 acres, Mazanola Clay loam over 4.2 acres with the remainder of the area consisting of Bressner-Truckton sandy loam and Sampson loam..

Nunn loam which generally has slopes of 0 to 3% and is found in streams and stream terraces. The soil is well drained and generally the depth to water table is 80 inches or greater. A typical profile is 0 to 3" of loam, 3 to 22" of Clay loam, and 22 to 60" contains Sandy clay

loam, fine sandy loam and sandy loam. A copy of the NCRS report is located in Appendix A, pages A.2 through A.16. Nunn loam is classified as Hydrologic Group C.

There are no major or minor drainage ways nor existing irrigation canals and ditches which are tributary to or traverse the site.

According to the Flood Insurance Rate Map (FIRM) published by FEMA, the subject property is referenced within Map Number 08035C0067F, latest Revision September 30, 2005. The subject property is indicated to be in Zone X which is defined as areas of minimal flooding outside of the 500 year flood area.

In order to ensure proper foundation construction of the future building a soils investigation has been performed by Ground Engineering. During that investigation ground water was found at 21' below existing grade. The soils engineer recommends that they be notified during the construction process to evaluate the need for an under drain around the building foundations, especially the extension of the downspouts beyond 10 from the foundation. MM&D Engineering experience indicates the downspout extension is a hit and miss situation during construction. Downspouts and splash blocks have a tendency to move during the final exterior covering of the building surfaces and may not be replaced immediately. We have had extensions left up during heavy spring downpours and during the thawing cycle of a snow storm. Both conditions have inundated the backfill immediate to the building and created problems later in the building's life.

### **III. DRAINAGE BASINS AND SUB-BASINS**

#### **A. Major Basin Description**

A major drainage study was completed for the Crown Point F#1 development on September 7, 2007 by J.R. Engineering. A more detailed report for Crown Point F#1, 14<sup>th</sup> Amendment was prepared by Merrick & Company on August 15, 2007. The project is located in the Cherry Creek major drainage way planning area and the Cherry Creek flood hazard area delineation. The project site is located in an unnamed Major Basin tributary to Cherry Creek, which drains approximately 600 acres towards the intersection of South Parker Road and Cottonwood Drive. The site is not within any floodplain as delineated on the FEMA FIRM Map No. 08035C0067F, dated September 30, 2005.

The drainage report complies with the previous reports prepared for the overall site titled *Crown Point F#1, 6<sup>th</sup> Amendment Final Drainage Report* dated August 2004 prepared by Merrick and Company as well as *Crown Point F#114<sup>th</sup> Amendment, Final Drainage Report*, dated August 15, 2007 prepared by Merrick and Company. Lot 4 release rates are compared later in the report with those anticipated in the 14<sup>th</sup> Amendment report. All runoff from the southern portion of Lot 4 will be directed into the existing storm sewer as installed with Lot 2 and the northern portion will be directed into an existing 42" that collects the runoff and transferred it under the access road to Cosco.

In order to provide better site visibility of the Boondocks Facility from the E-470, a portion of the berm along the E-470 exit ramp to Parker Road will be removed. However, the amount drainage flowing into the Boondocks site as well as the drainage into the E-470 ROW and borrow ditch will remain the same. The resultant drainage to E-470 will continue along the borrow ditch between the E-470 asphalt and the toe of the berm. The borrow ditch will remain in the same configuration, vertically as well as horizontally. Although the berm will be lowered, the top of the berm will divide the amount of runoff to both sides as it currently does.

## **B. Site Sub-basin Description**

### ***Developed On and Offsite Basins***

As described earlier the site is located at the northwest corner of E-470 and S Parker Road intersection. With the construction of E-470 all offsite flows that were historically conveyed across the site have been eliminated. The site historically drained from the east to the west to the Cosco site into existing storm sewer. All the flows are then routed to a "regional" detention pond located northwest of the site.

## **IV. DRAINAGE DESIGN CRITERIA**

### **A. Regulations**

The onsite drainage design complies with the *Town of Parker's Storm Drainage and Environmental Criteria Manual*, the final drainage report *Crown Point F#1, 14<sup>th</sup> Amendment* prepared by Merrick & Company, August 15, 2007, and the *Urban Storm drainage Manual* by Urban Drainage and Flood Control District. The report and plan also complies with the Town of Parker Flood Plain Ordinance.

As stated earlier the project is not within any 100 year mapped floodplain.

### **B. Compliance with Towns Stream Preservation Standards**

There are no streams which either traverse through or are adjacent to the project. As stated earlier that the overall drainage for the Crown point F#1 is collected in a common water quality and detention pond located on the west end of Crown Point. The water is then carried into Cherry Creek after water quality BMP's.

### **C. Development Reference Criteria and Constraints**

.This drainage design within this study conforms to the drainage design criteria proposed in *Crown Point F#1, 14<sup>th</sup> Amendment* by Merrick and Company. A comparison of the anticipated runoff flows and the actual calculated flows from our report is summed later in the Conclusions; Drainage Concept of this report.

Drainage Constraints of this site consist of the surrounding roads and storm sewer as well as the existing development of the Cosco site. The road constraints consist of E-470 on the west, Cottonwood Dr on the north, Parker Road & E-470 off ramp on the south, 18800 Road on the westerly upper portion of the site, and the Cosco parking lot and associated development structures on the southwestern side of the project. A vicinity map is attached in Appendix A which graphically defines the constraints. However even though these are physical constraints to the site, they are not necessarily a negative constraint. The runoff from the east has been blocked by the development of E-470, the runoff from the northeast is captured in storm sewer in Cottonwood Dr and is transported to a water quality/detention pond, with the development of 18800 Rd into the Cosco complex, a 42" RCP storm sewer was constructed under the access to the commercial site which is to collect runoff from 8.77 acres of the 14.875 acres contributing from the Boondocks/Commercial Site, and a 30" RCP storm sewer with 24" RCP stub-outs for collecting the runoff from the remaining acreage of the Boondocks/Commercial site. All storm runoff from the Boon/docks/Commercial site are collected in the existing storm sewer and directed into the master pond.

#### D. Hydrology Criteria

The Town of Parker drainage criteria requirements were followed in this report. The minor storm reflects the runoff generated by the 5 year storm and the major storm runoff reflects the runoff from the 100 year storm. All runoff was calculated utilizing the Rational Method for the model and the calculations are reproduced in Appendix B of this report. Since all the runoff from this project is collected into an existing storm sewer system and will be directed into an existing water quality/detention pond site, no ponds were required. The Master Drainage Study already has accounted for the flow generated by the development of Lot 4, Crown point F#1, 14<sup>th</sup> Amendment.

#### E. Hydraulic Criteria

There are no "streets" in this development. All access to the proposed buildings will be through private drive lanes. Maintenance of the parking and drive aisles will be the responsibility of the Owners Association. Storm sewer inlets and connecting storm sewer is anticipated to collect all the runoff from the site within the parking areas and be directed into the existing storm sewer. The attached drainage map indicates where the storm sewer is to be located at where it is to connect to the existing storm sewer. All storm sewer shall be a minimum of 18"RCP pipe per the Town of Parker's Criteria.

#### F. Variance From Criteria

There is no variance required with this project.

### V. Drainage Facility Design

#### A. General Concept

The project is divided into two major basin. Basin A consists of 21 sub-basins with a total acreage of 16.09 acres. The flows collected in Basins A.1 – A.6 are collected in inlets and connected to the existing 30" storm sewer which is in the road between Cosco and Boondocks. Basin A.7-A.21 collects runoff from approximately 7.19 acres and discharges into inlets proposed within the development. The flows with the A.7-A.21 Basins are directed to the existing 42" storm which crosses 18800 Rd. per the Crown point F#1 14<sup>th</sup> Amendment drainage report. The remaining Basin, Basin B, is also further subdivided into 4 sub-basins. Basin B.1 and B.2 collect runoff from the south portion of Cottonwood Dr. and it is added with the flows from Basin B.3 and B.4. Basins B.3 and B.4 collect runoff from the east side of 18800 Rd. The sum of the flows is then directed into an existing inlet at the southeast corner of Cottonwood Dr and 18800 Rd. The only offsite flows contributing to this project are those flows described in OS-1, Merrick Report for the 14<sup>th</sup> Amendment. The Merrick report reflects a flow of 5.0 cfs for the 5 year and 10.4 cfs for the 100 year flow within Cottonwood. The street calculations for flows at the flattest portion of the street (1.25%) reflects a depth of 5.1 inches for the 5 year and 6.2 inches for the 100 year. The engineer for this MM&D report added the flows from the OS-1 (Merrick) and determined the resulting flows within Cottonwood with Basins B.1 and B.2 added to OS-1 as 7.7 cfs for the 5 year and 14.3 cfs for the 100 year. The new flow depths in Cottonwood on the same grade reflect a depth of flow of 5.65 inches for the 5 year and 6.70 inches for the 100 year. The added flows will increase the depth of flow in Cottonwood approximately 0.5 inches for the 5 year and 100 year storms the street calculations are reproduced in Appendix C of this report.

The flows from the project are collected in existing storm sewer that was placed during the construction of the infrastructure of the Cosco commercial area. The flow from the southern end of the project is collected into an existing 30" pipe and directed to the existing water quality/detention pond at the west end of Crown Point F#1. The flow from the northern portion of the project is routed to an existing 42" culvert under road 18800 at the intersection about 300' south of the intersection of 18800 Rd and Cottonwood Dr. The 42" pipe is then proposed to traverse across Lot 3, Crown Point F#1 and connect with a 42" pipe located on the west side of Lot 3 where it is to discharge into the existing water quality/detention pond. However because Lot 3 has not been developed and the proposed 42" cannot be located at this time, the developer of Lot 4 and Lot 3 have come to an agreement that the existing 42" pipe that Lot 4 ties into, can daylight in an open channel and direct its flows into an existing temporary sediment control pond as described in the Crown Point F#1, 14<sup>th</sup> Amendment by Merrick and Company.

The accompanying Appendices contain the tables, charts, and figures required to model the proposed flows, inlet sizes and storm sewer determinations. The majority of the charts are reproduced from the Town of Parker Storm Drainage Criteria Manual or Urban Drainage and Flood Control Volumes. Appendix E contains the drainage map from the Merrick & Company report referenced herein. Its use is three fold, to give a graphic depiction of the drainage flow direction, the flow quantities expected at the connecting pipes from the Boondocks/commercial site as well as the intent of the engineered master plan.

Because of the master planning of the Crown Point F#! Project, there are no problems which occur with the development of Lot 4.

As previously discussed, all the flows generated within the project are collected in inlets located within the property or along the westerly adjoined accesses. The runoff will not be transported downstream other than in the controlled confines a storm sewer.

#### B. Specific Details

As previously explained the project is broken into two major basins ( A & B). The basins and their sub-basins are shown on the attached drainage map as well as the design points. Each design point reflects the runoff from the sub-basins for the 5 year and 100 year storms. The inlets were designed to capture 100% of the runoff. There are no problems associated with the design of this project. All flows are captured in a pipe and delivered to the points as delineated in the Crown Point F#1, 14<sup>th</sup> Amendment.

The design point summations and inlet size is reproduced on page C.16 of Appendix C. Inlets at DP 1 though DP 3 shall be type C inlet with close mesh grate. Inlets at DP 1 and DP 3 total flow assumes that all the internal private inlets are fully plugged with debris. All of the type C inlets are designed to be set at the elevation that will allow 100% of the total plugged flow to be captured. The inlets at DP 4 thru 13, DP 15 thru DP 17 are designed to be 5' type R inlets in sump condition. The flow at DP 14 is the anticipated flow that will pass through a proposed chase section.

DP 18, DP 19. & DP 20 are anticipated collection points for the commercial area which is not, at this time designed. The flows to the design points are assumed to be picked up in type R inlets, but because of the chance of a different layout, the size and type of inlets may be altered. Since the exact location of the collection points are not know, an 18" pipe will be

stubbed to the north to capture the flow from DP 18 & DP19 and an 18" pipe will be stubbed to the south to capture the flow from DP 20.

The design points associated with Basin B are B.1 thru B.4. DP B.1 reflects the flow which is in the existing curb of Cottonwood Dr. to Basin B.2. Basin B.2 flows are then routed to the intersection of Cottonwood Dr and 18800 DFR where it is added with flow from Basin B.4 at DP 24. DP.23 reflects the flow from Basin B.3 to the curb in Basin B.4. All flows from B.4 and B.2 are added and enter the existing 10' Type R inlet at the intersection of Cottonwood Dr and 18800 RD.

**C. Detention Storage Requirements**

Because a water quality/detention facility was designed with the Crown Point F#1, which is to accommodate all the runoff from the Crown Point Subdivision, neither detention or water quality is required.

**D. Outlet Requirements**

There are no requirements for an outlet configuration on the project.

**E. Storm Sewer Discussion & Swale Description**

The storm sewer calculations, inlet calculation and temporary swales are reproduced in Appendix C and D. Generally the proposed storm sewer is to connect to the existing storm sewer at DP 1, 2,3,4 on the south side and DP 28 on the north side. A graphical representation of those connections is shown on the attached drainage map. The swale calculation is also shown on Appendix D. The proposed channel is to transport the runoff from DP 28 across Lot 2 to the existing swale and the existing sediment ponds.

A summation of the comparison of the original design flows at DP 4 and DP 5 as shown in the Crown Point F#1, 14<sup>th</sup> Amendment with those of the total flow in the existing 30" RCP as it leaves the project, the 42" RCP as it collects runoff from the northern portion, and the discharge into the existing 10" Type R at Cottonwood Dr and 18800 Rd is as follows:

| <b>Flow in 30" RCP</b>           | <b>Q(5)</b> | <b>Q(100)</b> |
|----------------------------------|-------------|---------------|
| <b>14<sup>th</sup> Amendment</b> |             |               |
| <b>At DP 5</b>                   | <b>14.9</b> | <b>33.0</b>   |
| <b>This report DP 6</b>          | <b>7.6</b>  | <b>21.8</b>   |

| <b>Flow in 42" RCP</b>           |             |             |
|----------------------------------|-------------|-------------|
| <b>14<sup>th</sup> Amendment</b> |             |             |
| <b>At DP 4</b>                   | <b>32.9</b> | <b>70.3</b> |
| <b>This Report DP 28</b>         | <b>17.1</b> | <b>37.3</b> |

| <b>Flow at Cottonwood</b>        |            |             |
|----------------------------------|------------|-------------|
| <b>14<sup>th</sup> Amendment</b> |            |             |
| <b>At DP 3</b>                   | <b>7.1</b> | <b>14.6</b> |
| <b>This report</b>               | <b>2.2</b> | <b>13.8</b> |

As can be deduced from the flow comparison the amount of runoff is less than that which was originally calculated in the Merrick Report.

The flow from the 42" RCP needs to be routed in a grassed channel. Those calculations for this channel are located in Appendix D, pages D.25 and D.26. The channel is designed at a natural slope of 0.94%, with a 5' base and 4:1 side slopes.

#### F. Stormwater Utility Eligible Facilities

All of the onsite facilities are private. However, the discharge from the 42" across Lot 2 may be considered public since it is taking private water across an adjacent property.

### **VI. Environmental Protection Criteria**

#### A. General

The site contains 14.875 acres of undeveloped property. The area has previously been graded and the vegetative stand that was reseeded after construction appears to be about 70% coverage. The soils consist of weathered claystone/siltstone, claystone/siltstone and sandstone bedrock. This resubdivision of Lot 4 is being subdivided into 5 commercial lots, private drives and utilities.

There are no wetlands or potential T & E species. The site does not contain habitat protection areas or stream restoration. The site is in compliance with state and federal environmental permitting regulations. There are no variances requested for this project.

#### C. Construction BMP Plan

The site erosion control measures are to be placed on the site to reduce on site erosion, prevent sediment from entering the storm sewer system, and to eliminate sediment deposit runoff onto off-site properties. There currently exists one on site temporary sediment pond which will be utilized until other areas have been filled and stabilized with reseeded. Once the reseeded has been placed, the existing sediment pond will be filled and the outlet plugged in order to prevent any sediment from leaving the site. The inlets will be protected by inlet protection until construction has been completed. Any inlets that may continue to receive runoff from undeveloped areas will have the soil protection retained until full upstream development. All areas not covered by asphalt concrete, building or permanent landscaping shall be seeded with an approved native seed per the Towns specifications. The contractor shall be responsible for the inspection; maintaining and replacing erosion control measures during the construction sequence.

#### D. Permanent BMP Plan

All flows remain within the Crown Point F#1 development and are directed into an existing water quality/detention pond.

## **VII CONCLUSION**

### **A. Compliance with Standards**

The drainage report and calculations are in compliance with the Town of Parkers Storm Drainage and Environmental Criteria.

### **B. Drainage Concept**

The design presented in this report effectively controls the peak runoff generated from this site. Temporary erosion control sediment basin will be placed at undeveloped areas to control the release of sediment from the undeveloped sites. The development of the basin will be addressed in detail with the Grading Erosion Sediment Control Plan to be presented with final construction documents. The development of sites other than that of Boondocks is unknown at this time.

Storm drain pipes and inlets have been designed to accommodate the 100 year storm in all cases. Although all of the inlets are located on private property, they have been design with the Town Criteria for both the Type R and the Type C inlets.

### **C. Sediment & Erosion Control Concept**

The sediment and erosion control plan will effectively contain sediment and storm water quality through the interim and final stages of the plan.

**Final Drainage Report  
Crown Point F#1, 14<sup>th</sup> Amendment  
Parker, Colorado**

**REFERENCES**

1. United States Department of Agriculture Natural Resources Conservation Service. Soil survey of Castle Rock Area, Colorado.
2. Town of Parker. Storm Drainage and Environmental Criteria Manual. Revised February, 2014.
3. Federal Emergency Management Agency. F.E.M.A. flood Insurance Rate Map (FIRM) Douglas County, Colorado Community Panel Number 08035COO67F, Effective September 30, 2005.
4. Urban Drainage and Flood Control District. Urban Storm Drainage Criteria Manual June, 2001.
5. JR Engineering Final Drainage Report for Crown Point September, 2000.
6. Merrick & Company Crown Point Filing No. 1, 14<sup>th</sup> Amendment Final Drainage Report. August 15, 2007.
7. Haested Methods. Storm CAD.

**APPENDIX A**

**Vicinity Map, FEMA (FIRM) & SCS Soils Information**

## Location Map

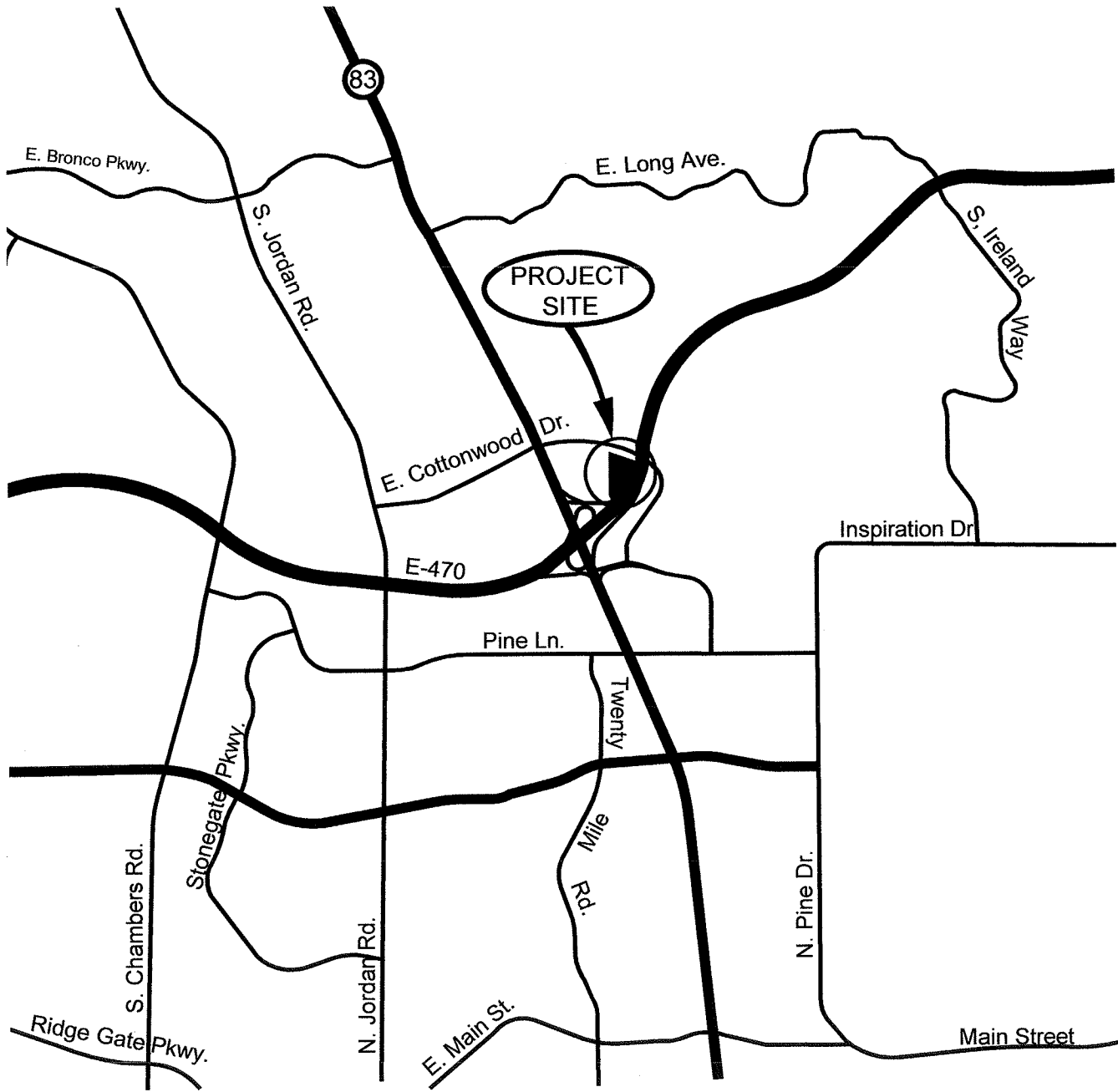

|  |   |
|--|---|
| <p><b>MM&amp;D Engineering Services, Inc.</b><br/> <u>William E. Miller, P.E.</u><br/> <b>ENGINEERING*CONSTRUCTION MANAGEMENT*SURVEYING</b><br/>                 9125 North Clydedale Road<br/>                 Castle Rock Colorado 80108<br/>                 PH (303) 908-0062 ★ FAX (303) 708-8399</p> | <p>Project Name:<br/> <b>Boondocks</b></p> <hr/> <p>DATE: 01/30/14<br/>                 DES/DFT: WEM/kem<br/>                 PROJ NO.: 13-343<br/>                 SHEET: 1 of 1</p> |
|--|---|

*Al*

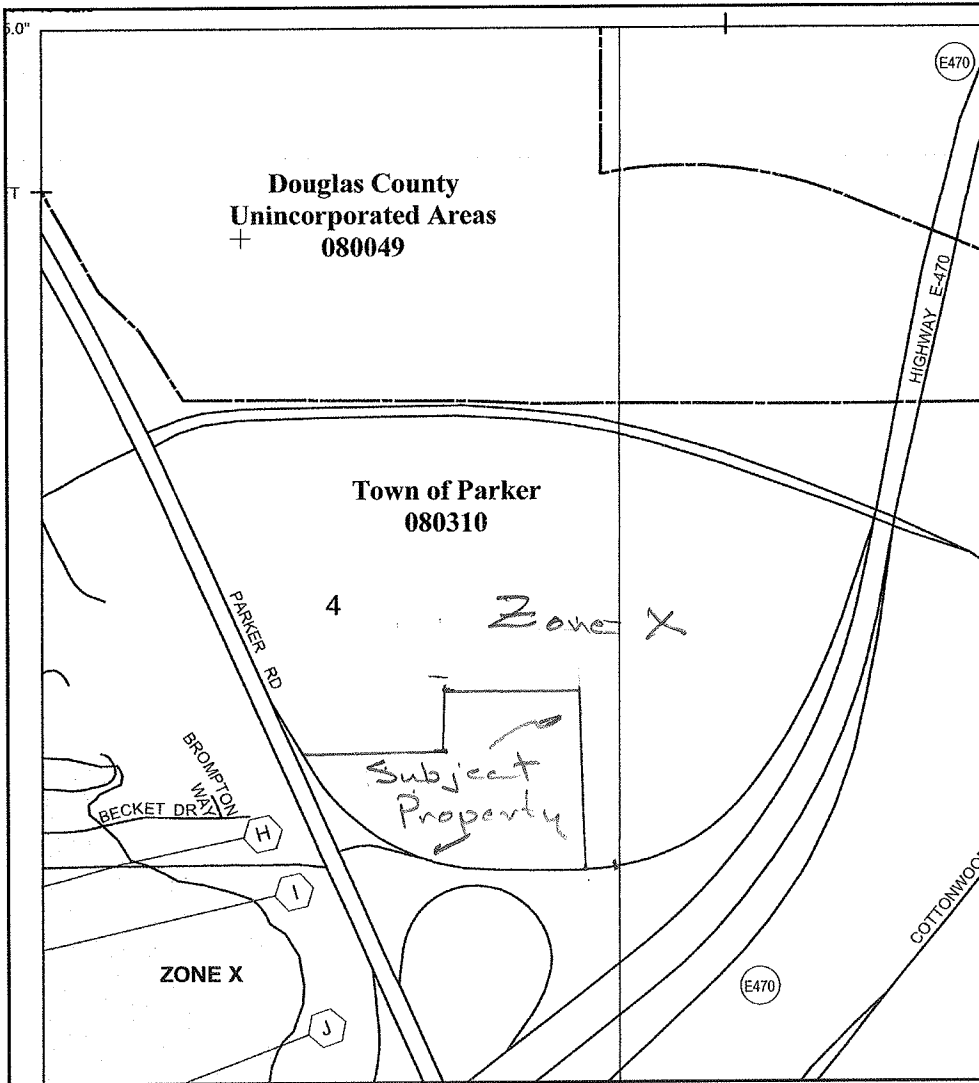

  
**MAP SCALE 1" = 500'**  
 500      1000  
 FEET

**PANEL 0067F**

**FIRM**  
**FLOOD INSURANCE RATE MAP**  
**DOUGLAS COUNTY,**  
**COLORADO**  
**AND INCORPORATED AREAS**

**PANEL 67 OF 495**  
 (SEE MAP INDEX FOR FIRM PANEL LAYOUT)

| CONTAINS        | COMMUNITY | NUMBER | PANEL | SUFFIX |
|-----------------|-----------|--------|-------|--------|
| DOUGLAS COUNTY  |           | 080049 | 0067  | F      |
| PARKER, TOWN OF |           | 080310 | 0067  | F      |

Notice to User: The Map Number shown below should be used when placing map orders; the Community Number shown above should be used on insurance applications for the subject community.

**MAP NUMBER**  
**08035C0067F**  
**EFFECTIVE DATE:**  
**SEPTEMBER 30, 2005**

**Federal Emergency Management Agency**

This is an official copy of a portion of the above referenced flood map. It was extracted using F-MIT On-Line. This map does not reflect changes or amendments which may have been made subsequent to the date on the title block. For the latest product information about National Flood Insurance Program flood maps check the FEMA Flood Map Store at [www.msc.fema.gov](http://www.msc.fema.gov)

A.2

Help

Zoom Win Print

Zoom In Zoom Out

MAX

Zoom In Zoom Out

Follow Instructions

Select page size

Letter 8.5x11

Legal 8.5x14

Tabloid 11x17

Select & Move Areas

Print Area

Scale and North Arrow

Title Block

Create PIR/Slide

Adobe PDF

map.pdf

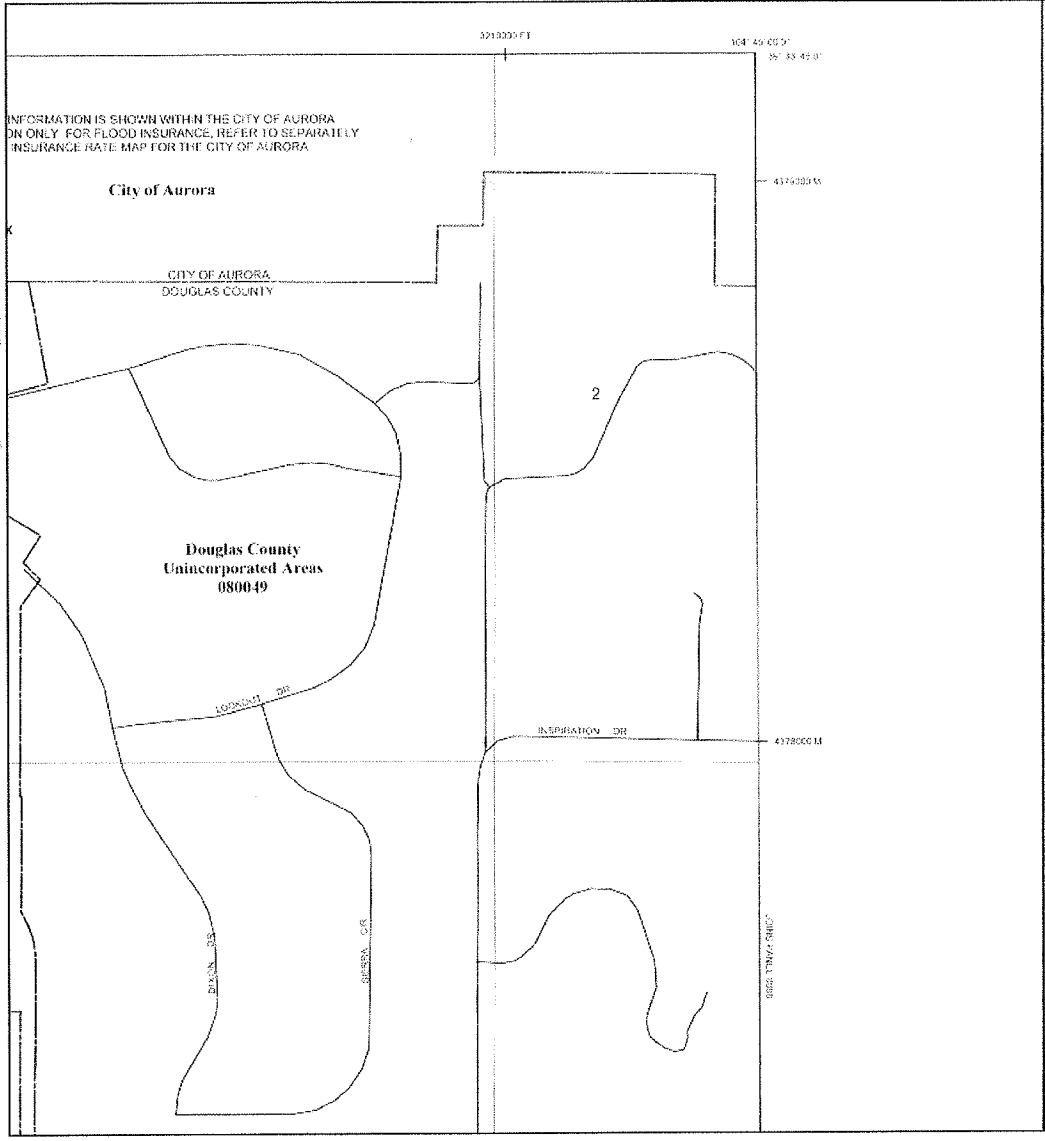

**SPECIAL FLOOD HAZARD AREAS (SFHAs) SUBJECT TO INHA BY THE 1% ANNUAL CHANCE FLOOD**

The 1% annual chance flood (100-year flood) is shown as the flood depth in the flood map and a 1% chance of being exceeded or equaled in any given year. The Special Flood Hazard Area is the area subject to flooding by the 1% annual chance flood. State of Oregon Flood Hazard zones are Zone A, AE, AH, AO, AR, AX, X, and Z. The Base Flood Elevation of the water surface elevation (BFE) is annual chance flood.

**ZONE A** No Base Flood Elevation determined.

**ZONE AE** Base Flood Elevation determined.

**ZONE AH** Flood depths of 1 to 3 feet (usually areas of parking). Base Flood Elevation determined.

**ZONE AO** Flood depths of 1 to 3 feet (usually street overtopping, terraces, lawns, depths determined). For areas of shallow fan flooding, velocities also determined.

**ZONE AR** Special Flood Hazard Area formerly protected from the 1% annual chance flood by a flood control system that was subsequently destroyed. For velocities that the former flood control system is being restored to give protection from the 1% annual chance flood.

**ZONE AX** Area to be protected from 1% annual chance flood by a Federal flood control system under construction, or base flood elevations determined.

**FLOODWAY AREAS IN ZONE AE**

The floodway is the channel of a stream plus any adjacent floodplain areas that must be kept unobstructed to carry the 1% annual chance flood to the river without substantial rise in flood heights.

**OTHER FLOOD AREAS**

**ZONE X** Areas of 0.2% annual chance flood; areas of 1% annual chance flood; storage depths of less than 1 foot in wet drainage areas. Also, Zone 1 only, and areas protected by levees from 1% annual chance flood.

**OTHER AREAS**

**ZONE X** Areas determined to be outside the 0.2% annual chance floodplain, but possibly:

**ZONE D** Areas in which flood hazards are undetermined, but possibly:

- Floodway boundary
- Boundary boundary
- Zone D boundary

Boundary defining Special Flood Hazard Area zones and boundary defining Special Flood Hazard Area of different flood elevations, flood depths or flood velocities.

513 Base Flood Elevation site and water elevation in feet.

DEL 8871 Base Flood Elevation value where uniform within zone boundaries only.

\*Reference to the North American Vertical Datum of 1988.

(A) (A) Cross section line.

104 50 32 00 39 50 00 Geographic coordinates, referenced to the North American Datum of 1983 (NAD 83), Western Hemisphere.

4275000 M North-North Universal Transverse Mercator grid (NAD 83).

3185000 FT 5000-foot U.S. Coastal State Plane coordinate system, central zone (SPS7000E 5003), Lambert Conformal Conic projection.

AK66460 National Geodetic Survey bench mark (see explanation below in the section of the FIRM panel).

**MAP REPOSITORY**  
Refer to listing of Map Repositories on Map Index

**EFFECTIVE DATE OF COUNTYWIDE FLOOD INSURANCE RATE MAP**  
SEPTEMBER 30, 2005

**EFFECTIVE DATE(S) OF REVISION(S) TO THIS PANEL**



United States  
Department of  
Agriculture

NRCS

Natural  
Resources  
Conservation  
Service

A product of the National  
Cooperative Soil Survey,  
a joint effort of the United  
States Department of  
Agriculture and other  
Federal agencies, State  
agencies including the  
Agricultural Experiment  
Stations, and local  
participants

# Custom Soil Resource Report for Castle Rock Area, Colorado

Boondocks



July 30, 2014

A-4

# Preface

---

Soil surveys contain information that affects land use planning in survey areas. They highlight soil limitations that affect various land uses and provide information about the properties of the soils in the survey areas. Soil surveys are designed for many different users, including farmers, ranchers, foresters, agronomists, urban planners, community officials, engineers, developers, builders, and home buyers. Also, conservationists, teachers, students, and specialists in recreation, waste disposal, and pollution control can use the surveys to help them understand, protect, or enhance the environment.

Various land use regulations of Federal, State, and local governments may impose special restrictions on land use or land treatment. Soil surveys identify soil properties that are used in making various land use or land treatment decisions. The information is intended to help the land users identify and reduce the effects of soil limitations on various land uses. The landowner or user is responsible for identifying and complying with existing laws and regulations.

Although soil survey information can be used for general farm, local, and wider area planning, onsite investigation is needed to supplement this information in some cases. Examples include soil quality assessments (<http://www.nrcs.usda.gov/wps/portal/nrcs/main/soils/health/>) and certain conservation and engineering applications. For more detailed information, contact your local USDA Service Center (<http://offices.sc.egov.usda.gov/locator/app?agency=nrcs>) or your NRCS State Soil Scientist ([http://www.nrcs.usda.gov/wps/portal/nrcs/detail/soils/contactus/?cid=nrcs142p2\\_053951](http://www.nrcs.usda.gov/wps/portal/nrcs/detail/soils/contactus/?cid=nrcs142p2_053951)).

Great differences in soil properties can occur within short distances. Some soils are seasonally wet or subject to flooding. Some are too unstable to be used as a foundation for buildings or roads. Clayey or wet soils are poorly suited to use as septic tank absorption fields. A high water table makes a soil poorly suited to basements or underground installations.

The National Cooperative Soil Survey is a joint effort of the United States Department of Agriculture and other Federal agencies, State agencies including the Agricultural Experiment Stations, and local agencies. The Natural Resources Conservation Service (NRCS) has leadership for the Federal part of the National Cooperative Soil Survey.

Information about soils is updated periodically. Updated information is available through the NRCS Web Soil Survey, the site for official soil survey information.

The U.S. Department of Agriculture (USDA) prohibits discrimination in all its programs and activities on the basis of race, color, national origin, age, disability, and where applicable, sex, marital status, familial status, parental status, religion, sexual orientation, genetic information, political beliefs, reprisal, or because all or a part of an individual's income is derived from any public assistance program. (Not all prohibited bases apply to all programs.) Persons with disabilities who require alternative means

for communication of program information (Braille, large print, audiotape, etc.) should contact USDA's TARGET Center at (202) 720-2600 (voice and TDD). To file a complaint of discrimination, write to USDA, Director, Office of Civil Rights, 1400 Independence Avenue, S.W., Washington, D.C. 20250-9410 or call (800) 795-3272 (voice) or (202) 720-6382 (TDD). USDA is an equal opportunity provider and employer.

# Contents

---

|   |    |
|---|----|
| <b>Preface</b> .....  | 2  |
| <b>How Soil Surveys Are Made</b> .....                        | 5  |
| <b>Soil Map</b> .....   | 7  |
| Soil Map.....   | 8  |
| Legend.....   | 9  |
| Map Unit Legend.....  | 10 |
| Map Unit Descriptions.....                                    | 10 |
| Castle Rock Area, Colorado.....                               | 12 |
| BrD—Bresser sandy loam, 3 to 9 percent slopes.....            | 12 |
| BtE—Bresser-Truckton sandy loams, 5 to 25 percent slopes..... | 13 |
| Ma—Manzanola clay loam.....                                   | 14 |
| Sa—Sampson loam.....  | 16 |
| <b>References</b> .....                                       | 18 |

# How Soil Surveys Are Made

---

Soil surveys are made to provide information about the soils and miscellaneous areas in a specific area. They include a description of the soils and miscellaneous areas and their location on the landscape and tables that show soil properties and limitations affecting various uses. Soil scientists observed the steepness, length, and shape of the slopes; the general pattern of drainage; the kinds of crops and native plants; and the kinds of bedrock. They observed and described many soil profiles. A soil profile is the sequence of natural layers, or horizons, in a soil. The profile extends from the surface down into the unconsolidated material in which the soil formed or from the surface down to bedrock. The unconsolidated material is devoid of roots and other living organisms and has not been changed by other biological activity.

Currently, soils are mapped according to the boundaries of major land resource areas (MLRAs). MLRAs are geographically associated land resource units that share common characteristics related to physiography, geology, climate, water resources, soils, biological resources, and land uses (USDA, 2006). Soil survey areas typically consist of parts of one or more MLRA.

The soils and miscellaneous areas in a survey area occur in an orderly pattern that is related to the geology, landforms, relief, climate, and natural vegetation of the area. Each kind of soil and miscellaneous area is associated with a particular kind of landform or with a segment of the landform. By observing the soils and miscellaneous areas in the survey area and relating their position to specific segments of the landform, a soil scientist develops a concept, or model, of how they were formed. Thus, during mapping, this model enables the soil scientist to predict with a considerable degree of accuracy the kind of soil or miscellaneous area at a specific location on the landscape.

Commonly, individual soils on the landscape merge into one another as their characteristics gradually change. To construct an accurate soil map, however, soil scientists must determine the boundaries between the soils. They can observe only a limited number of soil profiles. Nevertheless, these observations, supplemented by an understanding of the soil-vegetation-landscape relationship, are sufficient to verify predictions of the kinds of soil in an area and to determine the boundaries.

Soil scientists recorded the characteristics of the soil profiles that they studied. They noted soil color, texture, size and shape of soil aggregates, kind and amount of rock fragments, distribution of plant roots, reaction, and other features that enable them to identify soils. After describing the soils in the survey area and determining their properties, the soil scientists assigned the soils to taxonomic classes (units). Taxonomic classes are concepts. Each taxonomic class has a set of soil characteristics with precisely defined limits. The classes are used as a basis for comparison to classify soils systematically. Soil taxonomy, the system of taxonomic classification used in the United States, is based mainly on the kind and character of soil properties and the arrangement of horizons within the profile. After the soil scientists classified and named the soils in the survey area, they compared the

## Custom Soil Resource Report

individual soils with similar soils in the same taxonomic class in other areas so that they could confirm data and assemble additional data based on experience and research.

The objective of soil mapping is not to delineate pure map unit components; the objective is to separate the landscape into landforms or landform segments that have similar use and management requirements. Each map unit is defined by a unique combination of soil components and/or miscellaneous areas in predictable proportions. Some components may be highly contrasting to the other components of the map unit. The presence of minor components in a map unit in no way diminishes the usefulness or accuracy of the data. The delineation of such landforms and landform segments on the map provides sufficient information for the development of resource plans. If intensive use of small areas is planned, onsite investigation is needed to define and locate the soils and miscellaneous areas.

Soil scientists make many field observations in the process of producing a soil map. The frequency of observation is dependent upon several factors, including scale of mapping, intensity of mapping, design of map units, complexity of the landscape, and experience of the soil scientist. Observations are made to test and refine the soil-landscape model and predictions and to verify the classification of the soils at specific locations. Once the soil-landscape model is refined, a significantly smaller number of measurements of individual soil properties are made and recorded. These measurements may include field measurements, such as those for color, depth to bedrock, and texture, and laboratory measurements, such as those for content of sand, silt, clay, salt, and other components. Properties of each soil typically vary from one point to another across the landscape.

Observations for map unit components are aggregated to develop ranges of characteristics for the components. The aggregated values are presented. Direct measurements do not exist for every property presented for every map unit component. Values for some properties are estimated from combinations of other properties.

While a soil survey is in progress, samples of some of the soils in the area generally are collected for laboratory analyses and for engineering tests. Soil scientists interpret the data from these analyses and tests as well as the field-observed characteristics and the soil properties to determine the expected behavior of the soils under different uses. Interpretations for all of the soils are field tested through observation of the soils in different uses and under different levels of management. Some interpretations are modified to fit local conditions, and some new interpretations are developed to meet local needs. Data are assembled from other sources, such as research information, production records, and field experience of specialists. For example, data on crop yields under defined levels of management are assembled from farm records and from field or plot experiments on the same kinds of soil.

Predictions about soil behavior are based not only on soil properties but also on such variables as climate and biological activity. Soil conditions are predictable over long periods of time, but they are not predictable from year to year. For example, soil scientists can predict with a fairly high degree of accuracy that a given soil will have a high water table within certain depths in most years, but they cannot predict that a high water table will always be at a specific level in the soil on a specific date.

After soil scientists located and identified the significant natural bodies of soil in the survey area, they drew the boundaries of these bodies on aerial photographs and identified each as a specific map unit. Aerial photographs show trees, buildings, fields, roads, and rivers, all of which help in locating boundaries accurately.

# Soil Map

---

The soil map section includes the soil map for the defined area of interest, a list of soil map units on the map and extent of each map unit, and cartographic symbols displayed on the map. Also presented are various metadata about data used to produce the map, and a description of each soil map unit.



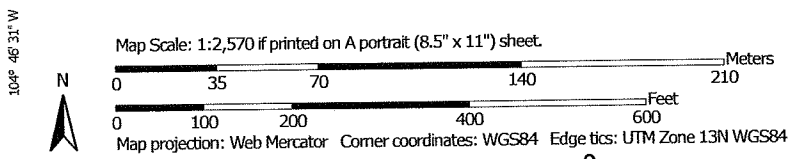
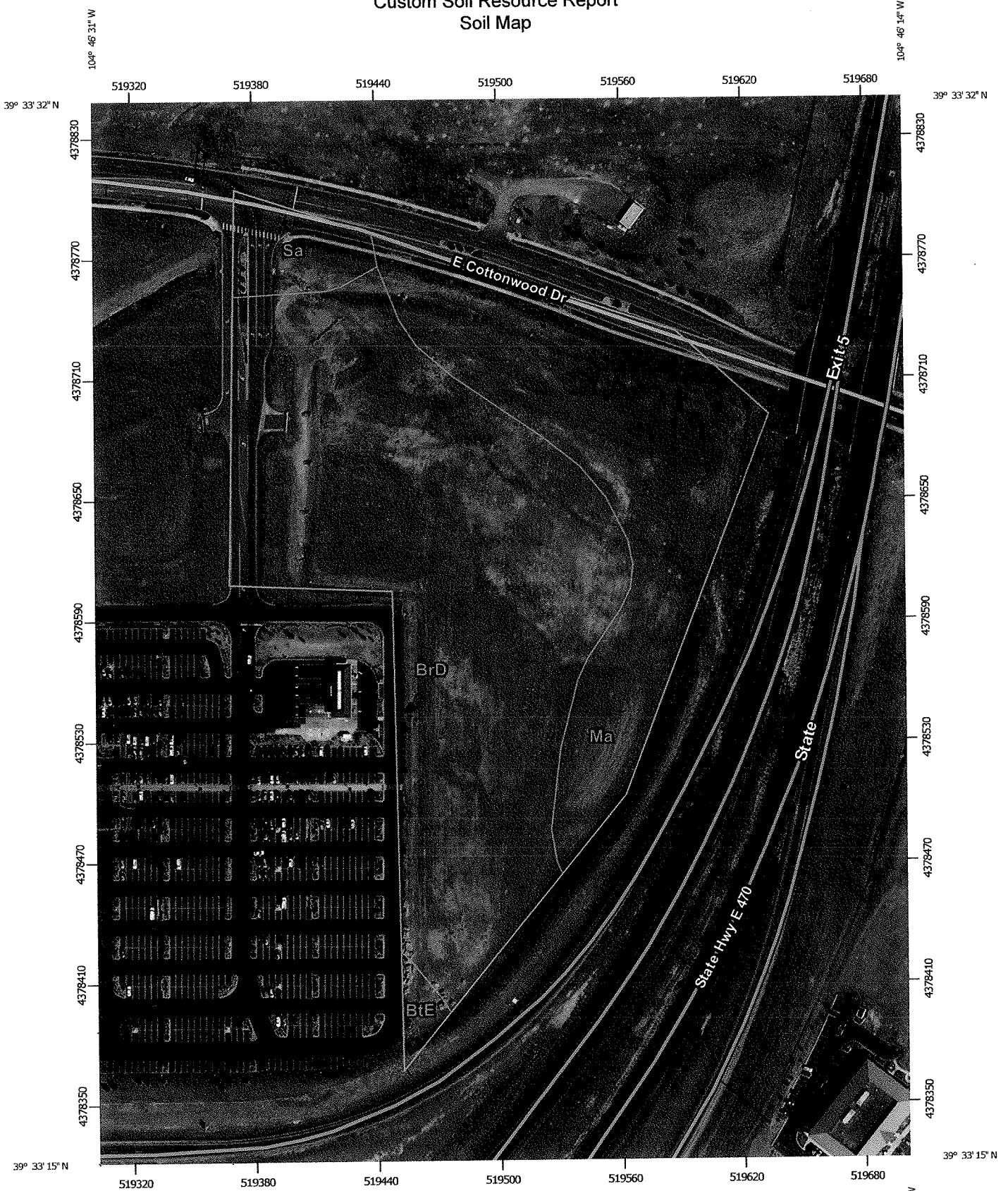

































# Custom Soil Resource Report Soil Map



A. 11

Custom Soil Resource Report

**MAP LEGEND**

|  |  |   |
|--|--|---|
| <b>Area of Interest (AOI)</b>  |  |  Spoil Area            |
|  Area of Interest (AOI) |  |  Stony Spot            |
| <b>Soils</b>   |  |  Very Stony Spot       |
|  Soil Map Unit Polygons |  |  Wet Spot              |
|  Soil Map Unit Lines    |  |  Other                 |
|  Soil Map Unit Points   |  |  Special Line Features |
| <b>Special Point Features</b>  |  | <b>Water Features</b>   |
|  Blowout                |  |  Streams and Canals    |
|  Borrow Pit             |  | <b>Transportation</b>   |
|  Clay Spot              |  |  Rails                 |
|  Closed Depression      |  |  Interstate Highways   |
|  Gravel Pit             |  |  US Routes            |
|  Gravelly Spot        |  |  Major Roads         |
|  Landfill             |  |  Local Roads         |
|  Lava Flow            |  | <b>Background</b>   |
|  Marsh or swamp       |  |  Aerial Photography  |
|  Mine or Quarry       |  |   |
|  Miscellaneous Water  |  |   |
|  Perennial Water      |  |   |
|  Rock Outcrop         |  |   |
|  Saline Spot          |  |   |
|  Sandy Spot           |  |   |
|  Severely Eroded Spot |  |   |
|  Sinkhole             |  |   |
|  Slide or Slip        |  |   |
|  Sodic Spot           |  |   |

**MAP INFORMATION**

The soil surveys that comprise your AOI were mapped at 1:20,000.

Warning: Soil Map may not be valid at this scale.

Enlargement of maps beyond the scale of mapping can cause misunderstanding of the detail of mapping and accuracy of soil line placement. The maps do not show the small areas of contrasting soils that could have been shown at a more detailed scale.

Please rely on the bar scale on each map sheet for map measurements.

Source of Map: Natural Resources Conservation Service  
 Web Soil Survey URL: <http://websoilsurvey.nrcs.usda.gov>  
 Coordinate System: Web Mercator (EPSG:3857)

Maps from the Web Soil Survey are based on the Web Mercator projection, which preserves direction and shape but distorts distance and area. A projection that preserves area, such as the Albers equal-area conic projection, should be used if more accurate calculations of distance or area are required.

This product is generated from the USDA-NRCS certified data as of the version date(s) listed below.

Soil Survey Area: Castle Rock Area, Colorado  
 Survey Area Data: Version 7, Dec 23, 2013

Soil map units are labeled (as space allows) for map scales 1:50,000 or larger.

Date(s) aerial images were photographed: Mar 16, 2012—Apr 13, 2012

The orthophoto or other base map on which the soil lines were compiled and digitized probably differs from the background imagery displayed on these maps. As a result, some minor shifting of map unit boundaries may be evident.

A.1.2

## Map Unit Legend

| Castle Rock Area, Colorado (CO622) |  |              |                |
|------------------------------------|--|--------------|----------------|
| Map Unit Symbol                    | Map Unit Name  | Acres in AOI | Percent of AOI |
| BrD                                | Bresser sandy loam, 3 to 9 percent slopes            | 9.2          | 61.7%          |
| BtE                                | Bresser-Truckton sandy loams, 5 to 25 percent slopes | 0.2          | 1.2%           |
| Ma                                 | Manzanola clay loam                                  | 4.9          | 32.7%          |
| Sa                                 | Sampson loam   | 0.7          | 4.4%           |
| <b>Totals for Area of Interest</b> |  | <b>15.0</b>  | <b>100.0%</b>  |

## Map Unit Descriptions

The map units delineated on the detailed soil maps in a soil survey represent the soils or miscellaneous areas in the survey area. The map unit descriptions, along with the maps, can be used to determine the composition and properties of a unit.

A map unit delineation on a soil map represents an area dominated by one or more major kinds of soil or miscellaneous areas. A map unit is identified and named according to the taxonomic classification of the dominant soils. Within a taxonomic class there are precisely defined limits for the properties of the soils. On the landscape, however, the soils are natural phenomena, and they have the characteristic variability of all natural phenomena. Thus, the range of some observed properties may extend beyond the limits defined for a taxonomic class. Areas of soils of a single taxonomic class rarely, if ever, can be mapped without including areas of other taxonomic classes. Consequently, every map unit is made up of the soils or miscellaneous areas for which it is named and some minor components that belong to taxonomic classes other than those of the major soils.

Most minor soils have properties similar to those of the dominant soil or soils in the map unit, and thus they do not affect use and management. These are called noncontrasting, or similar, components. They may or may not be mentioned in a particular map unit description. Other minor components, however, have properties and behavioral characteristics divergent enough to affect use or to require different management. These are called contrasting, or dissimilar, components. They generally are in small areas and could not be mapped separately because of the scale used. Some small areas of strongly contrasting soils or miscellaneous areas are identified by a special symbol on the maps. If included in the database for a given area, the contrasting minor components are identified in the map unit descriptions along with some characteristics of each. A few areas of minor components may not have been observed, and consequently they are not mentioned in the descriptions, especially where the pattern was so complex that it was impractical to make enough observations to identify all the soils and miscellaneous areas on the landscape.

The presence of minor components in a map unit in no way diminishes the usefulness or accuracy of the data. The objective of mapping is not to delineate pure taxonomic classes but rather to separate the landscape into landforms or landform segments that

## Custom Soil Resource Report

have similar use and management requirements. The delineation of such segments on the map provides sufficient information for the development of resource plans. If intensive use of small areas is planned, however, onsite investigation is needed to define and locate the soils and miscellaneous areas.

An identifying symbol precedes the map unit name in the map unit descriptions. Each description includes general facts about the unit and gives important soil properties and qualities.

Soils that have profiles that are almost alike make up a *soil series*. Except for differences in texture of the surface layer, all the soils of a series have major horizons that are similar in composition, thickness, and arrangement.

Soils of one series can differ in texture of the surface layer, slope, stoniness, salinity, degree of erosion, and other characteristics that affect their use. On the basis of such differences, a soil series is divided into *soil phases*. Most of the areas shown on the detailed soil maps are phases of soil series. The name of a soil phase commonly indicates a feature that affects use or management. For example, Alpha silt loam, 0 to 2 percent slopes, is a phase of the Alpha series.

Some map units are made up of two or more major soils or miscellaneous areas. These map units are complexes, associations, or undifferentiated groups.

A *complex* consists of two or more soils or miscellaneous areas in such an intricate pattern or in such small areas that they cannot be shown separately on the maps. The pattern and proportion of the soils or miscellaneous areas are somewhat similar in all areas. Alpha-Beta complex, 0 to 6 percent slopes, is an example.

An *association* is made up of two or more geographically associated soils or miscellaneous areas that are shown as one unit on the maps. Because of present or anticipated uses of the map units in the survey area, it was not considered practical or necessary to map the soils or miscellaneous areas separately. The pattern and relative proportion of the soils or miscellaneous areas are somewhat similar. Alpha-Beta association, 0 to 2 percent slopes, is an example.

An *undifferentiated group* is made up of two or more soils or miscellaneous areas that could be mapped individually but are mapped as one unit because similar interpretations can be made for use and management. The pattern and proportion of the soils or miscellaneous areas in a mapped area are not uniform. An area can be made up of only one of the major soils or miscellaneous areas, or it can be made up of all of them. Alpha and Beta soils, 0 to 2 percent slopes, is an example.

Some surveys include *miscellaneous areas*. Such areas have little or no soil material and support little or no vegetation. Rock outcrop is an example.

## Castle Rock Area, Colorado

### BrD—Bresser sandy loam, 3 to 9 percent slopes

#### Map Unit Setting

*Elevation:* 5,500 to 6,600 feet  
*Mean annual precipitation:* 15 to 19 inches  
*Mean annual air temperature:* 47 to 52 degrees F  
*Frost-free period:* 120 to 135 days

#### Map Unit Composition

*Bresser and similar soils:* 85 percent  
*Minor components:* 15 percent

#### Description of Bresser

##### Setting

*Landform:* Hills, ridges  
*Landform position (three-dimensional):* Side slope, crest, base slope  
*Down-slope shape:* Linear  
*Across-slope shape:* Linear  
*Parent material:* Sandy eolian deposits

##### Typical profile

*H1 - 0 to 8 inches:* sandy loam  
*H2 - 8 to 30 inches:* sandy clay loam  
*H3 - 30 to 60 inches:* loamy sand

##### Properties and qualities

*Slope:* 3 to 9 percent  
*Depth to restrictive feature:* More than 80 inches  
*Natural drainage class:* Well drained  
*Capacity of the most limiting layer to transmit water (Ksat):* Moderately high to high  
(0.20 to 2.00 in/hr)  
*Depth to water table:* More than 80 inches  
*Frequency of flooding:* None  
*Frequency of ponding:* None  
*Available water storage in profile:* Moderate (about 7.6 inches)

##### Interpretive groups

*Farmland classification:* Not prime farmland  
*Land capability classification (irrigated):* 4e  
*Land capability classification (nonirrigated):* 4e  
*Hydrologic Soil Group:* B  
*Ecological site:* Sandy Foothill (R049BY210CO)

#### Minor Components

##### Truckton

*Percent of map unit:* 5 percent

##### Bresser

*Percent of map unit:* 5 percent

##### Loamy alluvial land

*Percent of map unit:* 4 percent

## Custom Soil Resource Report

### **Aquic haplustolls**

*Percent of map unit:* 1 percent

*Landform:* Swales

## **BtE—Bresser-Truckton sandy loams, 5 to 25 percent slopes**

### **Map Unit Setting**

*Elevation:* 5,500 to 6,600 feet

*Mean annual precipitation:* 15 to 19 inches

*Mean annual air temperature:* 47 to 52 degrees F

*Frost-free period:* 120 to 135 days

### **Map Unit Composition**

*Bresser and similar soils:* 50 percent

*Truckton and similar soils:* 35 percent

*Minor components:* 15 percent

### **Description of Bresser**

#### **Setting**

*Landform:* Terraces

*Landform position (three-dimensional):* Tread, riser

*Down-slope shape:* Linear

*Across-slope shape:* Linear

*Parent material:* Sandy eolian deposits

#### **Typical profile**

*H1 - 0 to 8 inches:* sandy loam

*H2 - 8 to 30 inches:* sandy clay loam

*H3 - 30 to 60 inches:* loamy sand

#### **Properties and qualities**

*Slope:* 5 to 15 percent

*Depth to restrictive feature:* More than 80 inches

*Natural drainage class:* Well drained

*Capacity of the most limiting layer to transmit water (Ksat):* Moderately high to high  
(0.20 to 2.00 in/hr)

*Depth to water table:* More than 80 inches

*Frequency of flooding:* None

*Frequency of ponding:* None

*Available water storage in profile:* Moderate (about 7.6 inches)

#### **Interpretive groups**

*Farmland classification:* Not prime farmland

*Land capability classification (irrigated):* None specified

*Land capability classification (nonirrigated):* 6e

*Hydrologic Soil Group:* B

*Ecological site:* Sandy Foothill (R049BY210CO)

## Custom Soil Resource Report

### Description of Truckton

#### Setting

*Landform:* Terraces  
*Landform position (three-dimensional):* Tread, riser  
*Down-slope shape:* Linear  
*Across-slope shape:* Linear  
*Parent material:* Alluvium derived from arkosic sedimentary rock

#### Typical profile

*H1 - 0 to 4 inches:* sandy loam  
*H2 - 4 to 19 inches:* sandy loam  
*H3 - 19 to 60 inches:* sandy loam

#### Properties and qualities

*Slope:* 10 to 25 percent  
*Depth to restrictive feature:* More than 80 inches  
*Natural drainage class:* Well drained  
*Capacity of the most limiting layer to transmit water (Ksat):* High (2.00 to 6.00 in/hr)  
*Depth to water table:* More than 80 inches  
*Frequency of flooding:* None  
*Frequency of ponding:* None  
*Available water storage in profile:* Low (about 6.0 inches)

#### Interpretive groups

*Farmland classification:* Not prime farmland  
*Land capability classification (irrigated):* None specified  
*Land capability classification (nonirrigated):* 6e  
*Hydrologic Soil Group:* B

### Minor Components

#### Newlin

*Percent of map unit:* 5 percent

#### Blakeland

*Percent of map unit:* 5 percent

#### Stapleton

*Percent of map unit:* 4 percent

#### Aquic haplustolls

*Percent of map unit:* 1 percent  
*Landform:* Swales

### Ma—Manzanola clay loam

#### Map Unit Setting

*Elevation:* 5,500 to 6,200 feet  
*Mean annual precipitation:* 15 to 17 inches  
*Mean annual air temperature:* 49 to 54 degrees F

## Custom Soil Resource Report

*Frost-free period:* 120 to 135 days

### Map Unit Composition

*Manzanola and similar soils:* 85 percent

*Minor components:* 15 percent

### Description of Manzanola

#### Setting

*Landform:* Mesas, plateaus

*Down-slope shape:* Linear

*Across-slope shape:* Linear

*Parent material:* Alluvium derived from sedimentary rock and/or eolian deposits

#### Typical profile

*H1 - 0 to 8 inches:* clay loam

*H2 - 8 to 42 inches:* clay loam

*H3 - 42 to 60 inches:* clay loam

#### Properties and qualities

*Slope:* 3 to 6 percent

*Depth to restrictive feature:* More than 80 inches

*Natural drainage class:* Well drained

*Capacity of the most limiting layer to transmit water (Ksat):* Moderately low to moderately high (0.06 to 0.20 in/hr)

*Depth to water table:* More than 80 inches

*Frequency of flooding:* None

*Frequency of ponding:* None

*Calcium carbonate, maximum in profile:* 25 percent

*Gypsum, maximum in profile:* 2 percent

*Salinity, maximum in profile:* Nonsaline to slightly saline (2.0 to 8.0 mmhos/cm)

*Available water storage in profile:* High (about 10.7 inches)

#### Interpretive groups

*Farmland classification:* Not prime farmland

*Land capability classification (irrigated):* None specified

*Land capability classification (nonirrigated):* 4e

*Hydrologic Soil Group:* C

*Ecological site:* Clayey Foothill (R049BY208CO)

### Minor Components

#### Reno Hill

*Percent of map unit:* 5 percent

#### Satanta

*Percent of map unit:* 3 percent

#### Buick

*Percent of map unit:* 3 percent

#### Fondis

*Percent of map unit:* 2 percent

#### Newlin

*Percent of map unit:* 2 percent

## Sa—Sampson loam

### Map Unit Setting

*Elevation:* 5,500 to 6,600 feet  
*Mean annual precipitation:* 15 to 19 inches  
*Mean annual air temperature:* 48 to 50 degrees F  
*Frost-free period:* 120 to 135 days

### Map Unit Composition

*Sampson and similar soils:* 80 percent  
*Minor components:* 20 percent

### Description of Sampson

#### Setting

*Landform:* Stream terraces on drainageways  
*Landform position (three-dimensional):* Tread  
*Down-slope shape:* Linear  
*Across-slope shape:* Linear  
*Parent material:* Weathered alluvium derived from arkose

#### Typical profile

*H1 - 0 to 9 inches:* loam  
*H2 - 9 to 28 inches:* clay loam  
*H3 - 28 to 38 inches:* loam  
*H4 - 38 to 60 inches:* silt loam

#### Properties and qualities

*Slope:* 1 to 4 percent  
*Depth to restrictive feature:* More than 80 inches  
*Natural drainage class:* Well drained  
*Capacity of the most limiting layer to transmit water (Ksat):* Moderately high to high  
(0.60 to 2.00 in/hr)  
*Depth to water table:* More than 80 inches  
*Frequency of flooding:* None  
*Frequency of ponding:* None  
*Calcium carbonate, maximum in profile:* 15 percent  
*Salinity, maximum in profile:* Nonsaline (0.0 to 2.0 mmhos/cm)  
*Available water storage in profile:* High (about 9.5 inches)

#### Interpretive groups

*Farmland classification:* Farmland of statewide importance  
*Land capability classification (irrigated):* 3e  
*Land capability classification (nonirrigated):* 3c  
*Hydrologic Soil Group:* B  
*Ecological site:* Loamy Foothill (R049BY202CO)

## Custom Soil Resource Report

### Minor Components

#### **Englewood**

*Percent of map unit: 8 percent*

#### **Bresser**

*Percent of map unit: 7 percent*

#### **Loamy alluvial land**

*Percent of map unit: 4 percent*

#### **Aquic haplustolls**

*Percent of map unit: 1 percent*

*Landform: Swales*

# References

---

- American Association of State Highway and Transportation Officials (AASHTO). 2004. Standard specifications for transportation materials and methods of sampling and testing. 24th edition.
- American Society for Testing and Materials (ASTM). 2005. Standard classification of soils for engineering purposes. ASTM Standard D2487-00.
- Cowardin, L.M., V. Carter, F.C. Golet, and E.T. LaRoe. 1979. Classification of wetlands and deep-water habitats of the United States. U.S. Fish and Wildlife Service FWS/OBS-79/31.
- Federal Register. July 13, 1994. Changes in hydric soils of the United States.
- Federal Register. September 18, 2002. Hydric soils of the United States.
- Hurt, G.W., and L.M. Vasilas, editors. Version 6.0, 2006. Field indicators of hydric soils in the United States.
- National Research Council. 1995. Wetlands: Characteristics and boundaries.
- Soil Survey Division Staff. 1993. Soil survey manual. Soil Conservation Service. U.S. Department of Agriculture Handbook 18. [http://www.nrcs.usda.gov/wps/portal/nrcs/detail/national/soils/?cid=nrcs142p2\\_054262](http://www.nrcs.usda.gov/wps/portal/nrcs/detail/national/soils/?cid=nrcs142p2_054262)
- Soil Survey Staff. 1999. Soil taxonomy: A basic system of soil classification for making and interpreting soil surveys. 2nd edition. Natural Resources Conservation Service, U.S. Department of Agriculture Handbook 436. [http://www.nrcs.usda.gov/wps/portal/nrcs/detail/national/soils/?cid=nrcs142p2\\_053577](http://www.nrcs.usda.gov/wps/portal/nrcs/detail/national/soils/?cid=nrcs142p2_053577)
- Soil Survey Staff. 2010. Keys to soil taxonomy. 11th edition. U.S. Department of Agriculture, Natural Resources Conservation Service. [http://www.nrcs.usda.gov/wps/portal/nrcs/detail/national/soils/?cid=nrcs142p2\\_053580](http://www.nrcs.usda.gov/wps/portal/nrcs/detail/national/soils/?cid=nrcs142p2_053580)
- Tiner, R.W., Jr. 1985. Wetlands of Delaware. U.S. Fish and Wildlife Service and Delaware Department of Natural Resources and Environmental Control, Wetlands Section.
- United States Army Corps of Engineers, Environmental Laboratory. 1987. Corps of Engineers wetlands delineation manual. Waterways Experiment Station Technical Report Y-87-1.
- United States Department of Agriculture, Natural Resources Conservation Service. National forestry manual. [http://www.nrcs.usda.gov/wps/portal/nrcs/detail/soils/home/?cid=nrcs142p2\\_053374](http://www.nrcs.usda.gov/wps/portal/nrcs/detail/soils/home/?cid=nrcs142p2_053374)
- United States Department of Agriculture, Natural Resources Conservation Service. National range and pasture handbook. <http://www.nrcs.usda.gov/wps/portal/nrcs/detail/national/landuse/rangepasture/?cid=stelp2rb1043084>

## Custom Soil Resource Report

United States Department of Agriculture, Natural Resources Conservation Service. National soil survey handbook, title 430-VI. [http://www.nrcs.usda.gov/wps/portal/nrcs/detail/soils/scientists/?cid=nrcs142p2\\_054242](http://www.nrcs.usda.gov/wps/portal/nrcs/detail/soils/scientists/?cid=nrcs142p2_054242)

United States Department of Agriculture, Natural Resources Conservation Service. 2006. Land resource regions and major land resource areas of the United States, the Caribbean, and the Pacific Basin. U.S. Department of Agriculture Handbook 296. [http://www.nrcs.usda.gov/wps/portal/nrcs/detail/national/soils/?cid=nrcs142p2\\_053624](http://www.nrcs.usda.gov/wps/portal/nrcs/detail/national/soils/?cid=nrcs142p2_053624)

United States Department of Agriculture, Soil Conservation Service. 1961. Land capability classification. U.S. Department of Agriculture Handbook 210. [http://www.nrcs.usda.gov/Internet/FSE\\_DOCUMENTS/nrcs142p2\\_052290.pdf](http://www.nrcs.usda.gov/Internet/FSE_DOCUMENTS/nrcs142p2_052290.pdf)

**APPENDIX B**

**Hydrologic Calculations**

**Table RO-3—Recommended Percentage Imperviousness Values**

| Land Use or Surface Characteristics                   | Percentage Imperviousness |
|---|---------------------------|
| <b>Business:</b>                                      |                           |
| Commercial areas                                      | 95                        |
| Neighborhood areas                                    | 85                        |
| <b>Residential:</b>                                   |                           |
| Single-family   | *                         |
| Multi-unit (detached)                                 | 60                        |
| Multi-unit (attached)                                 | 75                        |
| Half-acre lot or larger                               | *                         |
| Apartments  | 80                        |
| <b>Industrial:</b>                                    |                           |
| Light areas   | 80                        |
| Heavy areas   | 90                        |
| Parks, cemeteries                                     | 5                         |
| Playgrounds   | 10                        |
| Schools   | 50                        |
| Railroad yard areas                                   | 15                        |
| <b>Undeveloped Areas:</b>                             |                           |
| Historic flow analysis                                | 2                         |
| Greenbelts, agricultural                              | 2                         |
| Off-site flow analysis<br>(when land use not defined) | 45                        |
| <b>Streets:</b>                                       |                           |
| Paved   | 100                       |
| Gravel (packed)                                       | 40                        |
| Drive and walks                                       | 90                        |
| Roofs   | 90                        |
| Lawns, sandy soil                                     | 0                         |
| Lawns, clayey soil                                    | 0                         |

\* See Figures RO-3 through RO-5 for percentage imperviousness.

$$C_A = K_A + (1.31i^3 - 1.44i^2 + 1.135i - 0.12) \text{ for } C_A \geq 0, \text{ otherwise } C_A = 0 \quad (\text{RO-6})$$

$$C_{CD} = K_{CD} + (0.858i^3 - 0.786i^2 + 0.774i + 0.04) \quad (\text{RO-7})$$

$$C_B = (C_A + C_{CD})/2$$

## Boondoks and Commercial Area

### Weighted I Values - Developed Values

Soil Types                      Bresser Sandy Loam and Sampson Loam  
All Hydrologic Group B  
6/04/15

| Typical I Values    | Imperviousness |
|---------------------|----------------|
| Building roof       | 90             |
| Parking Lots, Walks | 90             |
| Landscaping         | 5              |

| Basin Number | Building Roof (sf) | Parking Lots, Walks (sf) | Landscape (sf) | Total Area (sf) | Weighted Imperviousness | Total Area (ac) |
|--------------|--------------------|--------------------------|----------------|-----------------|-------------------------|-----------------|
| A.1          | 0                  | 2500                     | 33500          | 36000           | 11                      | 0.50            |
| A.2          | 2000               | 16250                    | 37250          | 55500           | 33                      | 1.27            |
| A.3          | 17500              | 30000                    | 52250          | 99750           | 45                      | 2.29            |
| A.4          | 8000               | 10000                    | 3250           | 21250           | 77                      | 0.49            |
| A.5          | 1000               | 11500                    | 0              | 12500           | 90                      | 0.29            |
| A.6          | 8000               | 25250                    | 0              | 33250           | 90                      | 0.76            |
| A.7          | 0                  | 10750                    | 0              | 10750           | 90                      | 0.25            |
| A.8          | 11500              | 6750                     | 6750           | 25000           | 67                      | 0.57            |
| A.9          | 35000              | 3000                     | 3000           | 41000           | 84                      | 0.94            |
| A.10         | 1000               | 2500                     | 2750           | 6250            | 53                      | 0.14            |
| A.11         | 0                  | 7750                     | 8250           | 16000           | 46                      | 0.37            |
| A.12         | 9650               | 17000                    | 0              | 26650           | 90                      | 0.61            |
| A.13         | 9000               | 16500                    | 0              | 25500           | 90                      | 0.59            |
| A.14         | 0                  | 7750                     | 3500           | 11250           | 64                      | 0.26            |
| A.15         | 3000               | 14500                    | 2500           | 20000           | 79                      | 0.46            |
| A.16         | 0                  | 8000                     | 0              | 8000            | 90                      | 0.18            |
| A.17         | 0                  | 10750                    | 0              | 10750           | 90                      | 0.25            |
| A.18         | 0                  | 24000                    | 0              | 24000           | 90                      | 0.55            |
| A.19         | 0                  | 17500                    | 0              | 17500           | 90                      | 0.40            |
| A.20         | 2750               | 16250                    | 0              | 19000           | 90                      | 0.44            |
| A.21         | 3250               | 48250                    | 0              | 51500           | 90                      | 1.18            |
| B.1          | 3900               | 4450                     | 15500          | 23850           | 35                      | 0.55            |
| B.2          | 7000               | 31600                    | 17500          | 56100           | 63                      | 1.29            |
| B.3          | 3500               | 25500                    | 3000           | 32000           | 82                      | 0.73            |
| B.4          | 0                  | 17250                    | 13750          | 31000           | 52                      | 0.71            |
| Total Basins | 126050             | 385550                   | 202750         | 714350          | 66                      | 16.07           |

**Table RO-5— Runoff Coefficients, C**

| Percentage Imperviousness | Type C and D NRCS Hydrologic Soil Groups  |      |       |       |       |        |
|---------------------------|---|------|-------|-------|-------|--------|
|                           | 2-yr                                      | 5-yr | 10-yr | 25-yr | 50-yr | 100-yr |
| 0%                        | 0.04                                      | 0.15 | 0.25  | 0.37  | 0.44  | 0.50   |
| 5%                        | 0.08                                      | 0.18 | 0.28  | 0.39  | 0.46  | 0.52   |
| 10%                       | 0.11                                      | 0.21 | 0.30  | 0.41  | 0.47  | 0.53   |
| 15%                       | 0.14                                      | 0.24 | 0.32  | 0.43  | 0.49  | 0.54   |
| 20%                       | 0.17                                      | 0.26 | 0.34  | 0.44  | 0.50  | 0.55   |
| 25%                       | 0.20                                      | 0.28 | 0.36  | 0.46  | 0.51  | 0.56   |
| 30%                       | 0.22                                      | 0.30 | 0.38  | 0.47  | 0.52  | 0.57   |
| 35%                       | 0.25                                      | 0.33 | 0.40  | 0.48  | 0.53  | 0.57   |
| 40%                       | 0.28                                      | 0.35 | 0.42  | 0.50  | 0.54  | 0.58   |
| 45%                       | 0.31                                      | 0.37 | 0.44  | 0.51  | 0.55  | 0.59   |
| 50%                       | 0.34                                      | 0.40 | 0.46  | 0.53  | 0.57  | 0.60   |
| 55%                       | 0.37                                      | 0.43 | 0.48  | 0.55  | 0.58  | 0.62   |
| 60%                       | 0.41                                      | 0.46 | 0.51  | 0.57  | 0.60  | 0.63   |
| 65%                       | 0.45                                      | 0.49 | 0.54  | 0.59  | 0.62  | 0.65   |
| 70%                       | 0.49                                      | 0.53 | 0.57  | 0.62  | 0.65  | 0.68   |
| 75%                       | 0.54                                      | 0.58 | 0.62  | 0.66  | 0.68  | 0.71   |
| 80%                       | 0.60                                      | 0.63 | 0.66  | 0.70  | 0.72  | 0.74   |
| 85%                       | 0.66                                      | 0.68 | 0.71  | 0.75  | 0.77  | 0.79   |
| 90%                       | 0.73                                      | 0.75 | 0.77  | 0.80  | 0.82  | 0.83   |
| 95%                       | 0.80                                      | 0.82 | 0.84  | 0.87  | 0.88  | 0.89   |
| 100%                      | 0.89                                      | 0.90 | 0.92  | 0.94  | 0.95  | 0.96   |
|                           | <b>TYPE B NRCS HYDROLOGIC SOILS GROUP</b> |      |       |       |       |        |
| 0%                        | 0.02                                      | 0.08 | 0.15  | 0.25  | 0.30  | 0.35   |
| 5%                        | 0.04                                      | 0.10 | 0.19  | 0.28  | 0.33  | 0.38   |
| 10%                       | 0.06                                      | 0.14 | 0.22  | 0.31  | 0.36  | 0.40   |
| 15%                       | 0.08                                      | 0.17 | 0.25  | 0.33  | 0.38  | 0.42   |
| 20%                       | 0.12                                      | 0.20 | 0.27  | 0.35  | 0.40  | 0.44   |
| 25%                       | 0.15                                      | 0.22 | 0.30  | 0.37  | 0.41  | 0.46   |
| 30%                       | 0.18                                      | 0.25 | 0.32  | 0.39  | 0.43  | 0.47   |
| 35%                       | 0.20                                      | 0.27 | 0.34  | 0.41  | 0.44  | 0.48   |
| 40%                       | 0.23                                      | 0.30 | 0.36  | 0.42  | 0.46  | 0.50   |
| 45%                       | 0.26                                      | 0.32 | 0.38  | 0.44  | 0.48  | 0.51   |
| 50%                       | 0.29                                      | 0.35 | 0.40  | 0.46  | 0.49  | 0.52   |
| 55%                       | 0.33                                      | 0.38 | 0.43  | 0.48  | 0.51  | 0.54   |
| 60%                       | 0.37                                      | 0.41 | 0.46  | 0.51  | 0.54  | 0.56   |
| 65%                       | 0.41                                      | 0.45 | 0.49  | 0.54  | 0.57  | 0.59   |
| 70%                       | 0.45                                      | 0.49 | 0.53  | 0.58  | 0.60  | 0.62   |
| 75%                       | 0.51                                      | 0.54 | 0.58  | 0.62  | 0.64  | 0.66   |
| 80%                       | 0.57                                      | 0.59 | 0.63  | 0.66  | 0.68  | 0.70   |
| 85%                       | 0.63                                      | 0.66 | 0.69  | 0.72  | 0.73  | 0.75   |
| 90%                       | 0.71                                      | 0.73 | 0.75  | 0.78  | 0.80  | 0.81   |
| 95%                       | 0.79                                      | 0.81 | 0.83  | 0.85  | 0.87  | 0.88   |
| 100%                      | 0.89                                      | 0.90 | 0.92  | 0.94  | 0.95  | 0.96   |

**TABLE RO-5 (Continued)—Runoff Coefficients, *C***

| Percentage Imperviousness | Type A NRCS Hydrologic Soils Group |      |       |       |       |        |
|---------------------------|------------------------------------|------|-------|-------|-------|--------|
|                           | 2-yr                               | 5-yr | 10-yr | 25-yr | 50-yr | 100-yr |
| 0%                        | 0.00                               | 0.00 | 0.05  | 0.12  | 0.16  | 0.20   |
| 5%                        | 0.00                               | 0.02 | 0.10  | 0.16  | 0.20  | 0.24   |
| 10%                       | 0.00                               | 0.06 | 0.14  | 0.20  | 0.24  | 0.28   |
| 15%                       | 0.02                               | 0.10 | 0.17  | 0.23  | 0.27  | 0.30   |
| 20%                       | 0.06                               | 0.13 | 0.20  | 0.26  | 0.30  | 0.33   |
| 25%                       | 0.09                               | 0.16 | 0.23  | 0.29  | 0.32  | 0.35   |
| 30%                       | 0.13                               | 0.19 | 0.25  | 0.31  | 0.34  | 0.37   |
| 35%                       | 0.16                               | 0.22 | 0.28  | 0.33  | 0.36  | 0.39   |
| 40%                       | 0.19                               | 0.25 | 0.30  | 0.35  | 0.38  | 0.41   |
| 45%                       | 0.22                               | 0.27 | 0.33  | 0.37  | 0.40  | 0.43   |
| 50%                       | 0.25                               | 0.30 | 0.35  | 0.40  | 0.42  | 0.45   |
| 55%                       | 0.29                               | 0.33 | 0.38  | 0.42  | 0.45  | 0.47   |
| 60%                       | 0.33                               | 0.37 | 0.41  | 0.45  | 0.47  | 0.50   |
| 65%                       | 0.37                               | 0.41 | 0.45  | 0.49  | 0.51  | 0.53   |
| 70%                       | 0.42                               | 0.45 | 0.49  | 0.53  | 0.54  | 0.56   |
| 75%                       | 0.47                               | 0.50 | 0.54  | 0.57  | 0.59  | 0.61   |
| 80%                       | 0.54                               | 0.56 | 0.60  | 0.63  | 0.64  | 0.66   |
| 85%                       | 0.61                               | 0.63 | 0.66  | 0.69  | 0.70  | 0.72   |
| 90%                       | 0.69                               | 0.71 | 0.73  | 0.76  | 0.77  | 0.79   |
| 95%                       | 0.78                               | 0.80 | 0.82  | 0.84  | 0.85  | 0.86   |
| 100%                      | 0.89                               | 0.90 | 0.92  | 0.94  | 0.95  | 0.96   |

# Boondocks & Commercial

6/04/15

## Weighted C Values

Soil Types Bresser Sandy Loam and Sampson Loam  
All Hydrologic Group B

| Basin Number | Total Area (ac) | Percent Imperviousness | 5 year | 100 year |
|--------------|-----------------|------------------------|--------|----------|
| A.1          | 0.50            | 11                     | 0.14   | 0.40     |
| A.2          | 1.27            | 33                     | 0.26   | 0.48     |
| A.3          | 2.29            | 45                     | 0.32   | 0.51     |
| A.4          | 0.49            | 77                     | 0.56   | 0.68     |
| A.5          | 0.29            | 90                     | 0.73   | 0.81     |
| A.6          | 0.76            | 90                     | 0.73   | 0.81     |
| A.7          | 0.25            | 90                     | 0.73   | 0.81     |
| A.8          | 0.57            | 67                     | 0.47   | 0.60     |
| A.9          | 0.94            | 84                     | 0.64   | 0.74     |
| A.10         | 0.14            | 53                     | 0.37   | 0.53     |
| A.11         | 0.37            | 46                     | 0.32   | 0.51     |
| A.12         | 0.61            | 90                     | 0.73   | 0.81     |
| A.13         | 0.59            | 90                     | 0.73   | 0.81     |
| A.14         | 0.26            | 64                     | 0.45   | 0.63     |
| A.15         | 0.46            | 79                     | 0.44   | 0.59     |
| A.16         | 0.18            | 90                     | 0.73   | 0.81     |
| A.17         | 0.25            | 90                     | 0.73   | 0.81     |
| A.18         | 0.55            | 90                     | 0.73   | 0.81     |
| A.19         | 0.40            | 90                     | 0.73   | 0.81     |
| A.20         | 0.44            | 90                     | 0.73   | 0.81     |
| A.21         | 1.18            | 90                     | 0.73   | 0.81     |
| B.1          | 0.55            | 36                     | 0.28   | 0.48     |
| B.2          | 1.29            | 64                     | 0.45   | 0.63     |
| B.3          | 0.73            | 82                     | 0.45   | 0.63     |
| B.4          | 0.71            | 52                     | 0.36   | 0.53     |
| Total        | 16.07           |                        |        |          |

**Boondocks & Commercial Area**  
**Summary Runoff Table**  
 12/19/14

| Basin ID                                 | DP | Contributing Area (acres) | Percent Imperv. % | Runoff Coefficient C (5 yr) | Runoff Coefficient C (100 yr) | Routed Flows 5 yr cfs | Routed Flows 100 yr cfs | Comments                                      |
|--|----|---------------------------|-------------------|-----------------------------|-------------------------------|-----------------------|-------------------------|---|
| A.1                                      | 1  | 0.50                      | 11                | 0.14                        | 0.40                          | 0.3                   | 1.3                     | single Type C with close mesh grate           |
| A.2                                      | 2  | 1.27                      | 33                | 0.26                        | 0.48                          | 1.25                  | 4.0                     | single Type C with close mesh grate           |
| A.3                                      | 3  | 2.29                      | 45                | 0.32                        | 0.51                          | 3.0                   | 8.9                     | single Type C with close mesh grate           |
| A.4                                      | 4  | 0.49                      | 77                | 0.58                        | 0.68                          | 1.3                   | 2.9                     | 5' type R inlet                               |
| A.5                                      | 5  | 0.29                      | 90                | 0.73                        | 0.81                          | 1.0                   | 2.1                     | 5' type R inlet                               |
| A.6                                      | 6  | 0.76                      | 90                | 0.73                        | 0.81                          | 2.6                   | 5.4                     | 5' type R inlet                               |
| A.7                                      | 7  | 0.25                      | 90                | 0.73                        | 0.81                          | 0.9                   | 1.8                     | 5' type R inlet                               |
| A.8                                      | 8  | 0.57                      | 67                | 0.47                        | 0.6                           | 1.3                   | 3                       | 5' type R inlet                               |
| A.9                                      | 9  | 0.94                      | 84                | 0.64                        | 0.74                          | 2.2                   | 4.8                     | 5' type R inlet                               |
| A.10                                     | 10 | 0.14                      | 53                | 0.37                        | 0.53                          | 0.2                   | 0.7                     | 5' type R inlet                               |
| A.11                                     | 11 | 0.37                      | 45                | 0.32                        | 0.51                          | 0.6                   | 1.7                     | 5' type R inlet                               |
| A.12                                     | 12 | 0.61                      | 90                | 0.73                        | 0.81                          | 2.1                   | 4.4                     | 5' type R inlet                               |
| A.13                                     | 13 | 0.59                      | 90                | 0.73                        | 0.81                          | 2.0                   | 4.2                     | 510' type R inlet                             |
| A.14                                     | 14 | 0.26                      | 64                | 0.45                        | 0.63                          | 0.6                   | 1.4                     | chase section to A.15                         |
| A.15                                     | 15 | 0.46                      | 79                | 0.44                        | 0.59                          | 1.0                   | 2.5                     |   |
| Sum A.14+A.15                            |    | 0.72                      |                   |                             |                               | 1.5                   | 3.7                     | 5' type R inlet                               |
| A.16                                     | 16 | 0.18                      | 90                | 0.73                        | 0.81                          | 0.6                   | 1.3                     | flow into basin A.17                          |
| A.17                                     | 17 | 0.25                      | 90                | 0.73                        | 0.81                          | 0.9                   | 1.8                     |   |
| Sum A.16+A.17                            |    | 0.43                      |                   |                             |                               | 1.4                   | 2.9                     | 5' type R inlet                               |
| A.18                                     | 18 | 0.55                      | 90                | 0.73                        | 0.81                          | 1.9                   | 3.9                     | future 5' type R with Commercial construction |
| A.19                                     | 19 | 0.40                      | 90                | 0.73                        | 0.81                          | 1.4                   | 2.9                     | future 5' type R with Commercial construction |
| A.20                                     | 20 | 0.44                      | 90                | 0.73                        | 0.81                          | 1.5                   | 3.1                     | future 5' type R with Commercial construction |
| A.21                                     | 21 | 1.18                      | 90                | 0.73                        | 0.81                          | 4.1                   | 8.4                     | future 5' type R with Commercial construction |
| B.1                                      | 22 | 0.55                      | 36                | 0.28                        | 0.48                          | 0.7                   | 2.3                     | flow into Basin B.2 in curb                   |
| B.2                                      | 23 | 1.29                      | 64                | 0.45                        | 0.63                          | 2.3                   | 6                       | includes flow from B.1                        |
| Sum B.1+B.2                              |    | 1.84                      |                   |                             |                               | 2.8                   | 7.5                     | To be added with (B.3+B.4)                    |
| Existing Flow from OS-1 (Merrick Report) |    | 1.62                      |                   |                             |                               | 5                     | 10.4                    |   |
| Total Sum OS-1 + B.1 + B.2               |    | 3.46                      |                   |                             |                               | 7.7                   | 16.8                    |   |
| B.3                                      | 24 | 0.73                      | 82                | 0.45                        | 0.63                          | 1.4                   | 3.7                     | flow into Basin B.4 in curb                   |
| B.4                                      | 25 | 0.71                      | 52                | 0.36                        | 0.63                          | 1.2                   | 3.9                     | includes flow from B.3                        |
| Sum B.3+B.4                              |    | 1.44                      |                   |                             |                               | 2.3                   | 6.5                     | To be added with (B.1+B.2)                    |
| Sum B.1-B.4                              |    | 0.14                      |                   |                             |                               | 9.8                   | 23.1                    | sum flow into exist. 10' type R               |

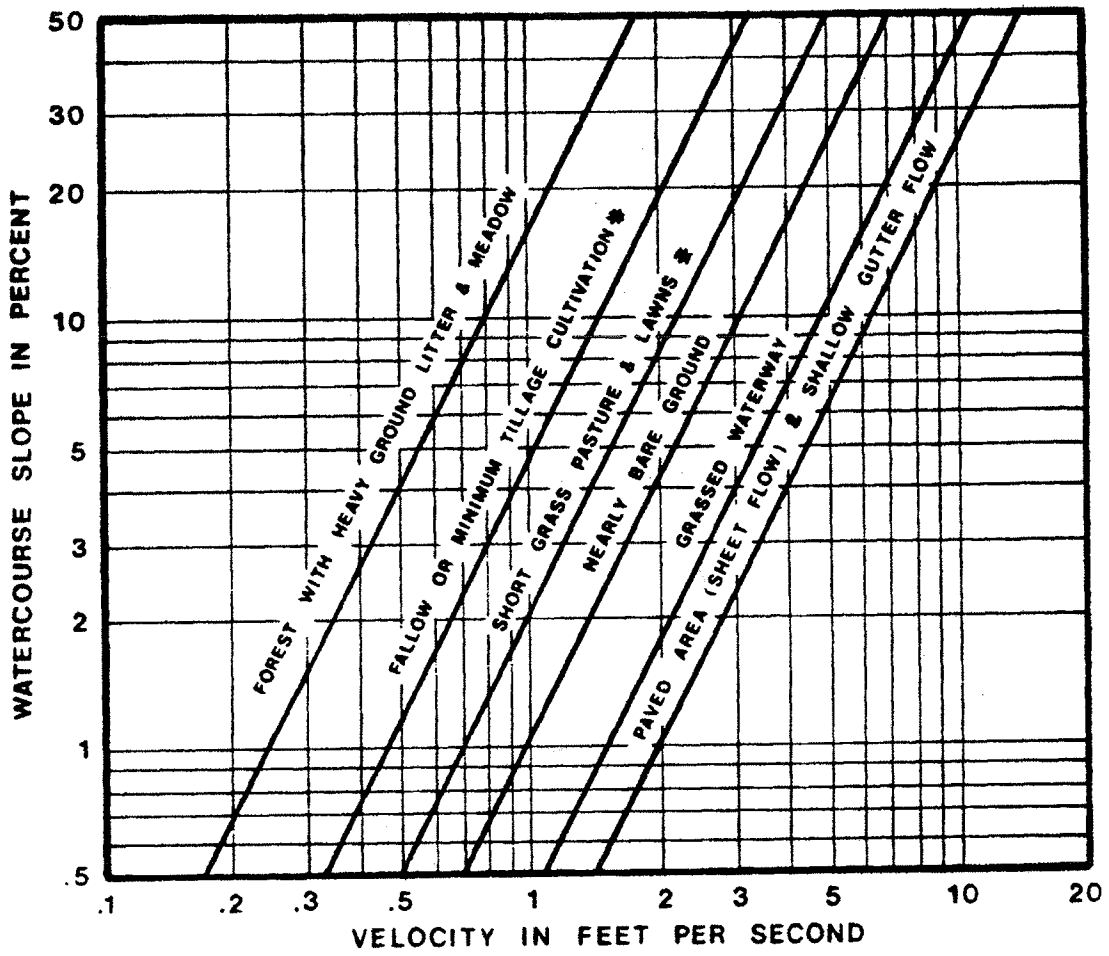

Figure RO-1—Estimate of Average Overland Flow Velocity for Use With the Rational Formula

**TABLE 5.1  
ONE-HOUR POINT RAINFALL**

| Frequency of Design<br>Event<br>(yr) | One-hour Point<br>Rainfall, P <sub>1</sub><br>(in) |
|--------------------------------------|--|
| 2                                    | 0.99   |
| 5                                    | 1.39   |
| 10                                   | 1.64   |
| 25                                   | 1.98   |
| 50                                   | 2.31   |
| 100                                  | 2.60   |

### 5.3 FLOOD HYDROLOGY OVERVIEW

Various methods exist to determine appropriate flood peaks or hydrographs for storm drainage planning and design. Methods for determining flood peaks or hydrographs are the Rational Method, the Colorado Urban Hydrograph Procedure (CUHP), and Urban Drainage Stormwater Management (UDSWM) model. The Town of Parker discourages the use of computer models other than CUHP and UDSWM since these programs are preferred, if not required, by UDFCD for studies involving major drainageways where UDFCD approval is sought or where maintenance eligibility is requested.

The three methods are briefly described in this section, and a discussion of their applicability to the Town of Parker is discussed. UDSWM is mostly used to combine and route the hydrographs generated using CUHP.

In general, the Rational Method is the most widely used and accepted technique for determining peak flows in urban areas for small basins. Within the constraints outlined in the MANUAL, use of the Rational Method provides a relatively simple but effective way to analyze storm runoff.

CUHP is somewhat more complicated than the Rational Method. It allows a manual computation of a runoff hydrograph which may be used for further hydraulic routing through channels and/or detention ponds. Historically, CUHP is best used in urban areas for which runoff coefficients have been derived. However, recent improvements by UDFCD include consideration for different soil types, thus CUHP is now more applicable to rural areas. The reader is referred to UDFCD for the latest version of CUHP.

UDSWM is a computer model that generates runoff hydrographs and routes and combines these hydrographs. UDSWM is a modified version of the Runoff Block of the Environmental Protection Agency's Storm Water Management Model (SWMM). It has been modified to be used in conjunction with CUHP. Table 5.2 herein provides guidance on selecting the appropriate method for a given project.

Intensity, Duration, Frequency  
Parker, Colorado

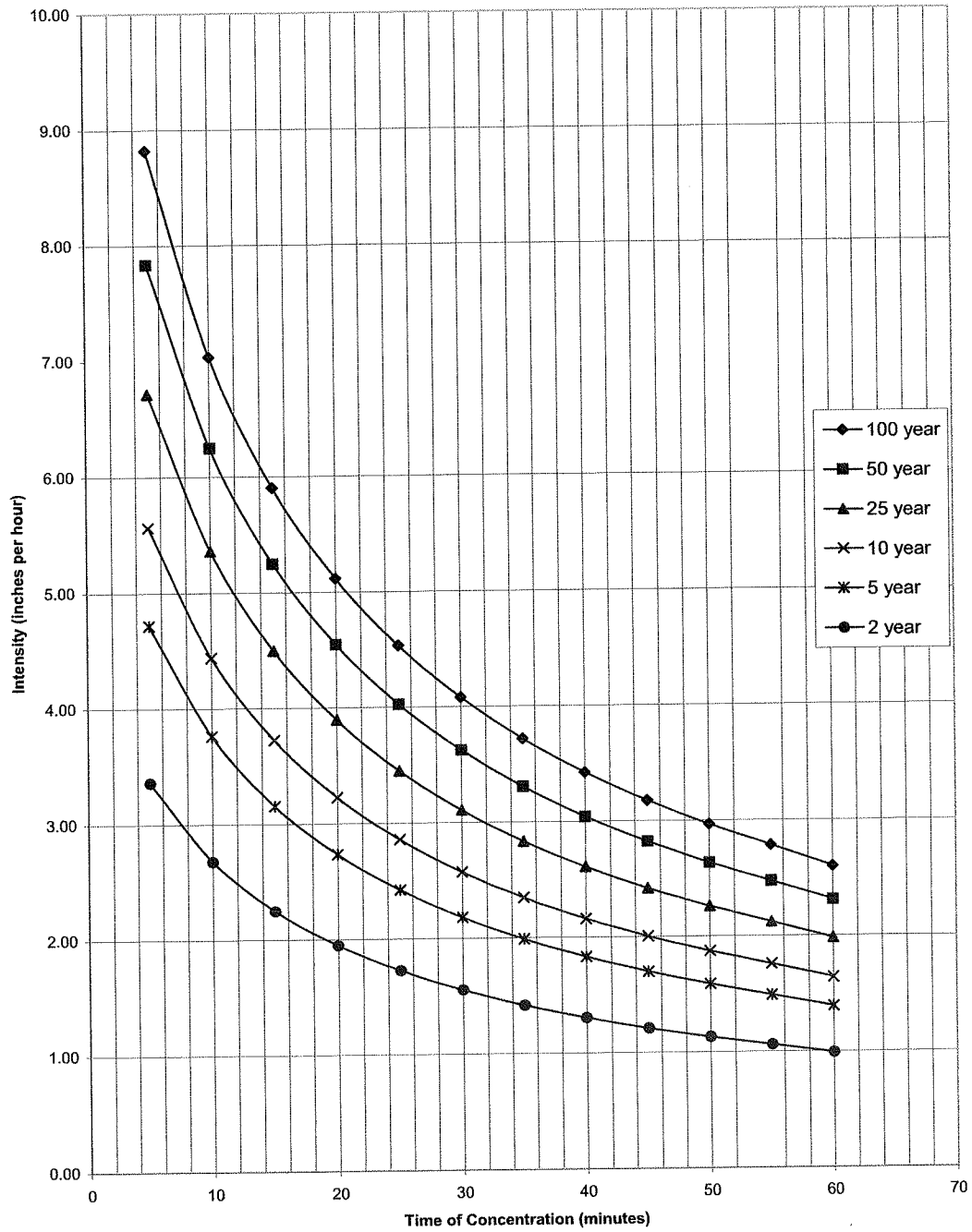

FIGURE 5.1  
RAINFALL INTENSITY VERSUS DURATION CURVES FOR PARKER, COLORADO

## TIME OF CONCENTRATION

Developed

**MM&D Engineering Consultants, inc.**

Calculated by **WEM**

Date **10/28/14**

Revised

Job num. **12-326**

Project **Boondocks & Commercial Arrea**

$$t_i = 0.395(1.1 - C_5)^*(L)^{0.5} / (S)^{0.33}$$

| Sub-Basin Data |      | Overland Time (ti) |      |              | Travel Time (tt) |           |              | tc Check (Urban Basins) |             |           | Final       |                   | REMARKS |                       |
|----------------|------|--------------------|------|--------------|------------------|-----------|--------------|-------------------------|-------------|-----------|-------------|-------------------|---------|-----------------------|
|                |      | AREA<br>Ac         | C5   | LENGTH<br>ft | SLOPE<br>%       | ti<br>min | LENGTH<br>ft | SLOPE<br>%              | Vel.<br>fps | tt<br>min | Comp.<br>tc | total leng.<br>ft |         | tc=(L/180)<br>+10 min |
| A.1            | 0.50 | 0.14               | 0.50 | 240          | 3.3              | 18.1      | 0            | 0.0                     | 0.0         | 0.0       | 18.1        | 240               | 11.3    | 11.3                  |
| A.2            | 1.27 | 0.26               | 0.50 | 240          | 1.7              | 19.7      | 100          | 4.0                     | 4.0         | 0.4       | 20.1        | 340               | 11.9    | 11.9                  |
| A.3            | 2.29 | 0.32               | 0.50 | 60           | 6.7              | 5.8       | 370          | 1.9                     | 2.7         | 2.3       | 8.1         | 430               | 12.4    | 8.1                   |
| A.4            | 0.49 | 0.58               | 0.50 | 5            | 2.0              | 1.7       | 280          | 4.2                     | 4.1         | 1.1       | 2.8         | 285               | 11.6    | 5.0                   |
| A.5            | 0.29 | 0.73               | 0.50 | 5            | 2.0              | 1.2       | 200          | 4.0                     | 4.0         | 0.8       | 2.0         | 205               | 11.1    | 5.0                   |
| A.6            | 0.76 | 0.73               | 0.50 | 5            | 2.0              | 1.2       | 350          | 4.3                     | 4.2         | 1.4       | 2.6         | 355               | 12.0    | 5.0                   |
| A.7            | 0.25 | 0.73               | 0.50 | 5            | 2.0              | 1.2       | 225          | 4.0                     | 4.0         | 0.9       | 2.1         | 230               | 11.3    | 5.0                   |
| A.8            | 0.57 | 0.47               | 0.50 | 5            | 2.0              | 2.0       | 50           | 2.0                     | 2.8         | 0.3       | 2.3         | 55                | 10.3    | 5.0                   |
| A.9            | 0.94 | 0.64               | 0.50 | 5            | 2.0              | 14.8      | 50           | 2.0                     | 2.8         | 0.3       | 15.1        | 55                | 10.3    | 10.3                  |
| A.10           | 0.14 | 0.37               | 0.50 | 5            | 2.0              | 2.3       | 50           | 2.0                     | 2.8         | 0.3       | 2.6         | 55                | 10.3    | 5.0                   |
| A.11           | 0.37 | 0.32               | 0.50 | 50           | 20.0             | 3.7       | 50           | 2.0                     | 2.8         | 0.3       | 4.0         | 100               | 10.6    | 5.0                   |
| A.12           | 0.61 | 0.73               | 0.50 | 5            | 2.0              | 1.2       | 130          | 3.1                     | 3.4         | 0.6       | 1.8         | 135               | 10.8    | 5.0                   |
| A.13           | 0.59 | 0.73               | 0.50 | 5            | 2.0              | 1.2       | 160          | 3.1                     | 3.4         | 0.8       | 2.0         | 1030              | 15.7    | 5.0                   |
| A.14           | 0.26 | 0.45               | 0.50 | 25           | 20.0             | 2.2       | 130          | 1.5                     | 2.4         | 0.9       | 3.1         | 155               | 10.9    | 5.0                   |

## TIME OF CONCENTRATION

Developed

**MM&D Engineering Consultants, inc.**

Calculated by **WEM**

Date **10/28/14**

Revised

Job num. **12-326**

Project **Boondocks & Commercial Arrea**

$$t_j = 0.395 \frac{(1.1 - C_5) \cdot (L)^{0.5}}{(S)^{0.33}}$$

| Sub-Basin Data |            | Overland Time (t <sub>i</sub> ) |            | Travel Time (t <sub>t</sub> ) |              |            | t <sub>c</sub> Check (Urban Basins) |                       | Final                   |                   | REMARKS |                       |
|----------------|------------|---------------------------------|------------|-------------------------------|--------------|------------|-------------------------------------|-----------------------|-------------------------|-------------------|---------|-----------------------|
| DESIGN         | AREA<br>Ac | LENGTH<br>ft                    | SLOPE<br>% | t <sub>i</sub><br>min         | LENGTH<br>ft | SLOPE<br>% | Vel.<br>fps                         | t <sub>t</sub><br>min | Comp.<br>t <sub>c</sub> | total leng.<br>ft |         | t <sub>c</sub><br>min |
| A.15           | 0.46       | 5                               | 2.0        | 2.1                           | 160          | 2.0        | 2.8                                 | 1.0                   | 3.1                     | 165               | 10.9    | 5.0                   |
| A.16           | 0.18       | 5                               | 2.0        | 1.2                           | 180          | 3.1        | 3.4                                 | 0.9                   | 2.1                     | 185               | 11.0    | 5.0                   |
| A.17           | 0.25       | 5                               | 2.0        | 1.2                           | 170          | 4.7        | 4.2                                 | 0.7                   | 1.9                     | 175               | 11.0    | 5.0                   |
| A.18           | 0.55       | 5                               | 2.0        | 1.2                           | 140          | 3.7        | 4.0                                 | 0.6                   | 1.8                     | 145               | 10.8    | 5.0                   |
| A.19           | 0.40       | 5                               | 2.0        | 1.2                           | 150          | 3.3        | 3.6                                 | 0.7                   | 1.9                     | 155               | 10.9    | 5.0                   |
| A.20           | 0.44       | 5                               | 2.0        | 1.2                           | 150          | 3.3        | 3.6                                 | 0.7                   | 1.9                     | 155               | 10.9    | 5.0                   |
| A.21           | 1.18       | 5                               | 2.0        | 1.2                           | 200          | 1.5        | 2.5                                 | 1.3                   | 2.5                     | 205               | 11.1    | 5.0                   |
| B.1            | 0.56       | 40                              | 10.0       | 4.4                           | 260          | 1.9        | 2.8                                 | 1.5                   | 5.9                     | 300               | 11.7    | 5.9                   |
| B.2            | 1.30       | 5                               | 2.0        | 2.1                           | 570          | 1.0        | 2.0                                 | 4.8                   | 6.8                     | 575               | 13.2    | 8.8                   |
| B.3            | 0.73       | 40                              | 2.0        | 5.9                           | 200          | 3.0        | 3.5                                 | 1.0                   | 6.9                     | 240               | 11.3    | 6.9                   |
| B.4            | 0.71       | 5                               | 2.0        | 2.4                           | 320          | 1.5        | 2.5                                 | 2.1                   | 4.5                     | 325               | 11.8    | 5.0                   |

**STORM DRAINAGE SYSTEM DESIGN  
(RATIONAL METHOD PROCEDURE)**

**MM&D Engineering Services, Inc.**

Calculated by WEM  
Date 10/29/14  
Revised I = (28.5P)/(10+tc) = 0.786

Job num. 13-343  
Project Boondocks & Commercial Property  
Design Storm 5.0 I = 1.39

| STREET  | DESIGN POINT | AREA DESIGN (acre) | AREA (acre) | RUNOFF COEFF. | tc min. | DIRECT RUNOFF |         |       | TOTAL RUNOFF |             |         | COMMENTS                  |       |  |
|---|--------------|--------------------|-------------|---------------|---------|---------------|---------|-------|--------------|-------------|---------|---------------------------|-------|--|
|   |              |                    |             |               |         | C * A         | I in/hr | Q cfs | tc min.      | C * A (sum) | I in/hr |                           | Q cfs |  |
| <b>Developed Basins</b>   |              |                    |             |               |         |               |         |       |              |             |         |                           |       |  |
| 5 year runoff   |              |                    |             |               |         |               |         |       |              |             |         |                           |       |  |
| 1   | A.1          | 0.50               | 0.14        | 11.3          | 0.07    | 3.6           | 0.3     |       |              |             |         | flows into Type C inlet   |       |  |
| 2   | A.2          | 1.27               | 0.26        | 11.9          | 0.33    | 3.5           | 1.2     |       |              |             |         | flows into Type C inlet   |       |  |
| 3   | A.3          | 2.29               | 0.32        | 8.1           | 0.73    | 4.1           | 3.0     |       |              |             |         | flows into Type C inlet   |       |  |
| 4   | A.4          | 0.49               | 0.58        | 5.0           | 0.28    | 4.7           | 1.3     |       |              |             |         | Flows into 5 Type R inlet |       |  |
| 5   | A.5          | 0.29               | 0.73        | 5.0           | 0.21    | 4.7           | 1.0     |       |              |             |         | Flows into 5 Type R inlet |       |  |
| 6   | A.6          | 0.76               | 0.73        | 5.0           | 0.55    | 4.7           | 2.6     |       |              |             |         | Flows into 5 Type R inlet |       |  |
| <b>Total Flow in existing 30" RCP; Sum (AC) = AC (DP 1 - DP 6) = 2.17</b> |              |                    |             |               |         |               |         |       |              | 11.9        | 2.17    | 3.5                       | 7.6   |  |
| 7   | A.7          | 0.25               | 0.73        | 5.0           | 0.18    | 4.7           | 0.9     |       |              |             |         | Flows into 5 Type R inlet |       |  |
| 8   | A.8          | 0.57               | 0.47        | 5.0           | 0.27    | 4.7           | 1.3     |       |              |             |         | Flows into 5 Type R inlet |       |  |
| 9   | A.9          | 0.94               | 0.64        | 10.3          | 0.60    | 3.7           | 2.2     |       |              |             |         | Flows into 5 Type R inlet |       |  |
| 10  | A.10         | 0.14               | 0.37        | 5.0           | 0.05    | 4.7           | 0.2     |       |              |             |         | Flows into 5 Type R inlet |       |  |
| 11  | A.11         | 0.37               | 0.32        | 5.0           | 0.12    | 4.7           | 0.6     |       |              |             |         | Flows into 5 Type R inlet |       |  |
| 12  | A.12         | 0.61               | 0.73        | 5.0           | 0.45    | 4.7           | 2.1     |       |              |             |         | Flows into 5 Type R inlet |       |  |

**STORM DRAINAGE SYSTEM DESIGN  
(RATIONAL METHOD PROCEDURE)**

**MM&D Engineering Services, Inc.**

Calculated by WEM  
Date 10/29/14  
Revised  $I = (28.5P)^{0.1} / (10 + t_c)^{0.786}$

Job num. 13-343  
Project Boondocks & Commercial Property  
Design Storm 5 year  $I = 1.39$

| STREET | DESIGN POINT | AREA DESIGN (acre) | AREA | RUNOFF COEF. | t <sub>c</sub> min. | DIRECT RUNOFF |   |   | TOTAL RUNOFF |   |   | COMMENTS |
|--------|--------------|--------------------|------|--------------|---------------------|---------------|---|---|--------------|---|---|----------|
|        |              |                    |      |              |                     | C * A         | I | Q | C * A        | I | Q |          |

**Developed Basins**

| 5 year runoff |  |      |      |     |      |      |     |  |  |  |  |   |
|---------------|--|------|------|-----|------|------|-----|--|--|--|--|---|
|               |  |      |      |     |      |      |     |  |  |  |  |   |
| 13            | A.13                                       | 0.59 | 0.73 | 5.0 | 0.43 | 4.7  | 2.0 |  |  |  |  | flows into 5' Type R inlet                    |
| 14            | A.14                                       | 0.26 | 0.45 | 5.0 | 0.12 | 4.7  | 0.6 |  |  |  |  | flows into chase & added with A.15            |
|               | A.15                                       | 0.48 | 0.44 | 5.0 | 0.21 | 4.7  | 1.0 |  |  |  |  | Flows into Type C inlets                      |
| 15            | Sum AC=A.14)+AC(A.15) = 0.21+0.12= 0.33    |      |      | 6.0 |      | 4.5  |     |  |  |  |  | t <sub>c</sub> = 5min + 1.0 travel time = 6.0 |
|               |  |      |      |     | 6.0  | 0.33 | 4.5 |  |  |  |  | 1.5 flows into 5' Type R inlet                |
| 16            | A.16                                       | 0.18 | 0.73 | 5.0 | 0.13 | 4.7  | 0.6 |  |  |  |  | Flows into A.17                               |
|               | A.17                                       | 0.25 | 0.73 | 5.0 | 0.18 | 4.7  | 0.9 |  |  |  |  | Flows into 5 Type R inlet                     |
|               | Sum AC=AC(A.16)+AC(A.17) = 0.13+0.18= 0.31 |      |      | 5.9 |      | 4.5  |     |  |  |  |  | t <sub>c</sub> = 5min + 0.9 travel time = 5.9 |
|               |  |      |      |     | 5.9  | 0.31 | 4.5 |  |  |  |  | 1.4 Flow into 5' Type R Inlet                 |
| 17            | A.18                                       | 0.55 | 0.73 | 5.0 | 0.40 | 4.7  | 1.9 |  |  |  |  | Flows into 5 Type R inlet                     |
| 18            | A.19                                       | 0.40 | 0.73 | 5.0 | 0.29 | 4.7  | 1.4 |  |  |  |  | Flows into 5 Type R inlet                     |
| 19            | A.20                                       | 0.44 | 0.73 | 5.0 | 0.32 | 4.7  | 1.5 |  |  |  |  | Flows into 5 Type R inlet                     |
| 20            | A.21                                       | 1.18 | 0.73 | 5.0 | 0.86 | 4.7  | 4.1 |  |  |  |  |   |

**Total flow into existing 42" RCP; Sum(AC) = AC(DP 7 to DP 20) = 4.63; T<sub>c</sub> = 10.7**  
 10.7    4.63    3.7    17.1

**STORM DRAINAGE SYSTEM DESIGN  
(RATIONAL METHOD PROCEDURE)**

**MM&D Engineering Services, Inc.**

Calculated by WEM  
Date 10/29/14  
Revised I = (28.5Pi)/(10\*tc)\*0.786

Job num. 13-343  
Project Boondocks & Commercial Property  
Design Storm 5 year I = 1.39

| STREET POINT  | DESIGN AREA                                   | AREA (acre) | RUNOFF COEF. | DIRECT RUNOFF |      |      | TOTAL RUNOFF |       |     | COMMENTS                             |
|---|---|-------------|--------------|---------------|------|------|--------------|-------|-----|--------------------------------------|
|   |   |             |              | C * A         | I    | Q    | tc           | C * A | I   |                                      |
|   |   |             |              | in/hr         | cfs  | min. | (sum)        | in/hr | cfs |                                      |
| <b>Developed Basins</b>                                 |   |             |              |               |      |      |              |       |     |                                      |
| 5 year runoff   |   |             |              |               |      |      |              |       |     |                                      |
| 21  | B.1   | 0.55        | 0.28         | 5.9           | 0.15 | 4.5  | 0.7          |       |     | flows into Basin B.2                 |
|   | B.2   | 1.29        | 0.45         | 8.8           | 0.58 | 3.9  | 2.3          |       |     |                                      |
| 22  | Sum AC=AC(B.1)+AC(B.2) = 0.15+0.58=0.73       |             |              |               |      |      |              |       |     | tc = 5.9 min + 4.5 travel time = 0.4 |
|   |   |             |              | 10.4          | 3.7  | 10.4 | 0.73         | 3.7   | 2.7 | 2.7 flow to be added with B.4        |
| <b>Total flow added to Flow in Cottonwood</b>           |   |             |              |               |      |      |              |       |     |                                      |
| Existing flow in Cottonwood from Merrick Report at DP 7 |   |             |              |               |      |      |              |       |     |                                      |
|   |   |             |              |               |      | 8.2  | 1.24         | 4.0   | 5.0 |                                      |
|   |   |             |              |               |      | 10.4 | 2.07         | 3.7   | 7.7 |                                      |
| Total flow in street = (7.3)+(1.24)=2.07                |   |             |              |               |      |      |              |       |     |                                      |
| 23  | B.3   | 0.73        | 0.45         | 6.9           | 0.33 | 4.3  | 1.4          |       |     | flow to be added with B.4            |
|   | B.4   | 0.71        | 0.36         | 5.0           | 0.26 | 4.7  | 1.2          |       |     |                                      |
| 24  | Sum AC=AC(B.3)+AC(B.4) = 0.33+0.26=0.59       |             |              |               |      |      |              |       |     | tc = 6.9 min + 2.1 travel time = 9.0 |
|   |   |             |              | 9.0           | 3.9  | 9.0  | 0.59         | 3.9   | 2.3 | 2.3 flow to be added with B.4        |
| 25  | Total flow leaving Basin B.4 to north         |             |              |               |      |      |              |       |     |                                      |
|   | Sum AC=AC(DP 22)+AC(BDP 24) = 2.07+0.59= 2.66 |             |              |               |      |      |              |       |     |                                      |
|   |   |             |              | 10.4          | 3.7  | 10.4 | 2.66         | 3.7   | 9.8 | 9.8 Flow into existing inlet         |

**STORM DRAINAGE SYSTEM DESIGN  
(RATIONAL METHOD PROCEDURE)**

**MM&D Engineering Services, Inc.**

Calculated by WEM  
Date 10/29/14  
Revised I = (28.5P)/(10+tc) = 0.786

Job num. 13-343  
Project Boondocks & Commercial Property  
Design Storm 100 year I = 2.60

| STREET   | DESIGN POINT | AREA DESIGN (acre) | AREA RUNOFF (acre) | COEF. | tc min. | DIRECT RUNOFF |         |       | TOTAL RUNOFF |             |         | COMMENTS |                           |
|--|--------------|--------------------|--------------------|-------|---------|---------------|---------|-------|--------------|-------------|---------|----------|---------------------------|
|  |              |                    |                    |       |         | C * A         | I in/hr | Q cfs | tc min.      | C * A (sum) | I in/hr |          | Q cfs                     |
| <b>Developed Basins</b>  |              |                    |                    |       |         |               |         |       |              |             |         |          |                           |
| 100 year runoff  |              |                    |                    |       |         |               |         |       |              |             |         |          |                           |
| 1  | A.1          | 0.50               | 0.40               | 0.40  | 11.3    | 0.20          | 6.7     | 1.3   |              |             |         |          | flows into Type C inlet   |
| 2  | A.2          | 1.27               | 0.48               | 0.48  | 11.9    | 0.61          | 6.5     | 4.0   |              |             |         |          | flows into Type C inlet   |
| 3  | A.3          | 2.29               | 0.51               | 0.51  | 8.1     | 1.17          | 7.6     | 8.9   |              |             |         |          | flows into Type C inlet   |
| 4  | A.4          | 0.49               | 0.68               | 0.68  | 5.0     | 0.33          | 8.8     | 2.9   |              |             |         |          | Flows into 5 Type R inlet |
| 5  | A.5          | 0.29               | 0.81               | 0.81  | 5.0     | 0.23          | 8.8     | 2.1   |              |             |         |          | Flows into 5 Type R inlet |
| 6  | A.6          | 0.76               | 0.81               | 0.81  | 5.0     | 0.62          | 8.8     | 5.4   |              |             |         |          | Flows into 5 Type R inlet |
| <b>Total Flow in existing 30" RCP; Sum (AC) = AC (DP 1 - DP 6) = 3.36; Tc = 11.9 min</b> |              |                    |                    |       |         |               |         |       |              |             |         |          |                           |
| 11.9 3.36 6.5 21.8   |              |                    |                    |       |         |               |         |       |              |             |         |          |                           |
| 7  | A.7          | 0.25               | 0.81               | 0.81  | 5.0     | 0.20          | 8.8     | 1.8   |              |             |         |          | Flows into 5 Type R inlet |
| 8  | A.8          | 0.57               | 0.60               | 0.60  | 5.0     | 0.34          | 8.8     | 3.0   |              |             |         |          | Flows into 5 Type R inlet |
| 9  | A.9          | 0.94               | 0.74               | 0.74  | 10.3    | 0.70          | 7.0     | 4.8   |              |             |         |          | Flows into 5 Type R inlet |
| 10   | A.10         | 0.14               | 0.53               | 0.53  | 5.0     | 0.07          | 8.8     | 0.7   |              |             |         |          | Flows into 5 Type R inlet |
| 11   | A.11         | 0.37               | 0.51               | 0.51  | 5.0     | 0.19          | 8.8     | 1.7   |              |             |         |          | Flows into 5 Type R inlet |
| 12   | A.12         | 0.61               | 0.81               | 0.81  | 5.0     | 0.49          | 8.8     | 4.4   |              |             |         |          | Flows into 5 Type R inlet |

B.15

**STORM DRAINAGE SYSTEM DESIGN  
(RATIONAL METHOD PROCEDURE)**

**MM&D Engineering Services, Inc.**

Calculated by **WEM**  
Date **10/29/14**  
Revised **I = (28.5P)/(10+tc)^0.786**

Job num. **13-343**  
Project **Boondocks & Commercial Property**  
Design Storm **100 year I = 2.60**

| STREET                  | DESIGN POINT                              | AREA DESIGN (acre) | AREA | RUNOFF COEF. | tc min. | DIRECT RUNOFF |      |     | TOTAL RUNOFF |             |   | COMMENTS   |
|-------------------------|---|--------------------|------|--------------|---------|---------------|------|-----|--------------|-------------|---|--|
|                         |   |                    |      |              |         | C * A         | I    | Q   | tc min.      | C * A (sum) | I |  |
|                         |   |                    |      |              |         | in/hr         | cfs  |     | in/hr        | cfs         |   |  |
| <b>Developed Basins</b> |   |                    |      |              |         |               |      |     |              |             |   |  |
| 100 year runoff         |   |                    |      |              |         |               |      |     |              |             |   |  |
| <b>13</b>               | A.13                                      | 0.59               | 0.48 | 8.8          | 4.2     |               |      |     |              |             |   | flows into 5' Type R inlet   |
| <b>14</b>               | A.14                                      | 0.26               | 0.16 | 8.8          | 1.4     |               |      |     |              |             |   | flows into chase & added with A.15                                 |
|                         | A.15                                      | 0.48               | 0.28 | 8.8          | 2.5     |               |      |     |              |             |   | Flows into Type C inlets   |
| <b>15</b>               | Sum AC=A.14)+AC(A.15) = 0.16+0.28=0.44    |                    |      |              |         | 6.0           | 0.44 | 8.4 | 3.7          |             |   | tc = 5min + 1.0 travel time = 6.0<br>3.7 flows into 5' type R      |
| <b>16</b>               | A.16                                      | 0.18               | 0.15 | 8.8          | 1.3     |               |      |     |              |             |   | Flows into A.17  |
|                         | A.17                                      | 0.25               | 0.20 | 8.8          | 1.8     |               |      |     |              |             |   | Flows into 5 Type R inlet  |
| <b>16</b>               | Sum AC=AC(A.16)+AC(A.17) = 0.15+0.20=0.35 |                    |      |              |         | 5.9           | 0.35 | 8.4 | 2.9          |             |   | tc = 5min + 0.9 travel time = 5.9<br>2.9 Flow into 5' Type R Inlet |
| <b>17</b>               | A.18                                      | 0.55               | 0.45 | 8.8          | 3.9     |               |      |     |              |             |   | Flows into 5 Type R inlet  |
| <b>18</b>               | A.19                                      | 0.40               | 0.32 | 8.8          | 2.9     |               |      |     |              |             |   | Flows into 5 Type R inlet  |
| <b>19</b>               | A.20                                      | 0.44               | 0.36 | 8.8          | 3.1     |               |      |     |              |             |   | Flows into 5 Type R inlet  |
| <b>20</b>               | A.21                                      | 1.18               | 0.96 | 8.8          | 8.4     |               |      |     |              |             |   | Flows into 5 Type R inlet  |

**Total flow into existing 42" RCP; Sum(AC) = AC(DP 7 to DP 20) = 5.33 ; Tc = 10.7**  
 10.7    5.33    7.0    37.3

**STORM DRAINAGE SYSTEM DESIGN  
(RATIONAL METHOD PROCEDURE)**

**MM&D Engineering Services, Inc.**

Calculated by WEM Job num. 13-343  
 Date 10/29/14 Project Boondocks & Commercial Property  
 I = (28.5P)/(10+tc)^0.786 Design Storm 100 year I = 2.6  
 Revised 6/03/15

| STREET POINT  | DESIGN AREA (acre)                       | AREA DESIGN | RUNOFF COEF. | DIRECT RUNOFF |       |         |       | TOTAL RUNOFF |             |         |       | COMMENTS |                                      |
|---|--|-------------|--------------|---------------|-------|---------|-------|--------------|-------------|---------|-------|----------|--------------------------------------|
|   |  |             |              | tc min.       | C * A | I in/hr | Q cfs | tc min.      | C * A (sum) | I in/hr | Q cfs |          |                                      |
| <b>Developed Basins</b>                                 |  |             |              |               |       |         |       |              |             |         |       |          |                                      |
| 100 year runoff   |  |             |              |               |       |         |       |              |             |         |       |          |                                      |
| 21  | B.1                                      | 0.55        | 1.29         | 5.9           | 0.71  | 8.4     | 6.0   |              |             |         |       |          | flows into Basin B.2                 |
| 22  | B.2                                      | 1.30        | 0.63         | 8.8           | 0.82  | 7.4     | 6.0   |              |             |         |       |          | tc = 5.9 min + 4.5 travel time = 0.4 |
|   | Sum AC=AC(B.1)+AC(B.2) = 0.71+0.82= 1.03 |             |              |               |       |         |       | 10.4         | 1.03        | 6.9     | 7.1   |          | 10.4 flow to be added with B.4       |
| <b>Total flow added to Flow in Cottonwood</b>           |  |             |              |               |       |         |       |              |             |         |       |          |                                      |
| Existing flow in Cottonwood from Merrick Report at DP 7 |  |             |              |               |       |         |       |              |             |         |       |          |                                      |
|   |  |             |              |               |       |         |       | 8.1          | 1.41        | 7.4     | 10.4  |          | 10.4 flow to be added with B.4       |
|   |  |             |              |               |       |         |       | 10.4         | 2.44        | 6.9     | 16.8  |          | tc = 6.9 min + 2.1 travel time = 9.0 |
| 23  | B.3                                      | 0.73        | 0.63         | 6.9           | 0.46  | 8.0     | 3.7   |              |             |         |       |          | flow to be added with B.4            |
| 24  | B.4                                      | 0.71        | 0.63         | 5.0           | 0.45  | 8.8     | 3.9   |              |             |         |       |          |                                      |
|   | Sum AC=AC(B.3)+AC(B.4) = 0.46+0.45= 0.91 |             |              |               |       |         |       | 9.0          | 0.91        | 7.3     | 6.6   |          |                                      |
| 25  | Total flow leaving Basin B.4 to north    |             |              |               |       |         |       |              |             |         |       |          |                                      |
|   |  |             |              |               |       |         |       |              |             |         |       |          |                                      |
|   |  |             |              |               |       |         |       | 10.4         | 3.35        | 6.9     | 23.1  |          |                                      |
|   |  |             |              |               |       |         |       | 10.4         | 3.35        | 6.9     | 23.1  |          |                                      |

**Boondocks & Commercial Area**  
**Summary Runoff Table**  
 12/19/14

| Basin ID                                 | DP | Contributing Area (acres) | Percent Imperv. % | Runoff Coefficient C (5 yr) | Runoff Coefficient C (100 yr) | Routed Flows 5 yr cfs | Routed Flows 100 yr cfs | Comments                                      |
|--|----|---------------------------|-------------------|-----------------------------|-------------------------------|-----------------------|-------------------------|---|
| A.1                                      | 1  | 0.50                      | 11                | 0.14                        | 0.40                          | 0.3                   | 1.3                     | single Type C with close mesh grate           |
| A.2                                      | 2  | 1.27                      | 33                | 0.26                        | 0.48                          | 1.25                  | 4.0                     | single Type C with close mesh grate           |
| A.3                                      | 3  | 2.29                      | 45                | 0.32                        | 0.51                          | 3.0                   | 8.9                     | single Type C with close mesh grate           |
| A.4                                      | 4  | 0.49                      | 77                | 0.58                        | 0.68                          | 1.3                   | 2.9                     | 5' type R inlet                               |
| A.5                                      | 5  | 0.29                      | 90                | 0.73                        | 0.81                          | 1.0                   | 2.1                     | 5' type R inlet                               |
| A.6                                      | 6  | 0.76                      | 90                | 0.73                        | 0.81                          | 2.6                   | 5.4                     | 5' type R inlet                               |
| A.7                                      | 7  | 0.25                      | 90                | 0.73                        | 0.81                          | 0.9                   | 1.8                     | 5' type R inlet                               |
| A.8                                      | 8  | 0.57                      | 67                | 0.47                        | 0.6                           | 1.3                   | 3                       | 5' type R inlet                               |
| A.9                                      | 9  | 0.94                      | 84                | 0.64                        | 0.74                          | 2.2                   | 4.8                     | 5' type R inlet                               |
| A.10                                     | 10 | 0.14                      | 53                | 0.37                        | 0.53                          | 0.2                   | 0.7                     | 5' type R inlet                               |
| A.11                                     | 11 | 0.37                      | 45                | 0.32                        | 0.51                          | 0.6                   | 1.7                     | 5' type R inlet                               |
| A.12                                     | 12 | 0.61                      | 90                | 0.73                        | 0.81                          | 2.1                   | 4.4                     | 5' type R inlet                               |
| A.13                                     | 13 | 0.59                      | 90                | 0.73                        | 0.81                          | 2.0                   | 4.2                     | 510' type R inlet                             |
| A.14                                     | 14 | 0.26                      | 64                | 0.45                        | 0.63                          | 0.6                   | 1.4                     | chase section to A.15                         |
| A.15                                     | 15 | 0.46                      | 79                | 0.44                        | 0.59                          | 1.0                   | 2.5                     |   |
| Sum A.14+A.15                            |    | 0.72                      |                   |                             |                               | 1.5                   | 3.7                     | 5' type R inlet                               |
| A.16                                     | 16 | 0.18                      | 90                | 0.73                        | 0.81                          | 0.6                   | 1.3                     | flow into basin A.17                          |
| A.17                                     | 17 | 0.25                      | 90                | 0.73                        | 0.81                          | 0.9                   | 1.8                     |   |
| Sum A.16+A.17                            |    | 0.43                      |                   |                             |                               | 1.4                   | 2.9                     | 5' type R inlet                               |
| A.18                                     | 18 | 0.55                      | 90                | 0.73                        | 0.81                          | 1.9                   | 3.9                     | future 5' type R with Commercial construction |
| A.19                                     | 19 | 0.40                      | 90                | 0.73                        | 0.81                          | 1.4                   | 2.9                     | future 5' type R with Commercial construction |
| A.20                                     | 20 | 0.44                      | 90                | 0.73                        | 0.81                          | 1.5                   | 3.1                     | future 5' type R with Commercial construction |
| A.21                                     | 21 | 1.18                      | 90                | 0.73                        | 0.81                          | 4.1                   | 8.4                     | future 5' type R with Commercial construction |
| B.1                                      | 22 | 0.55                      | 36                | 0.28                        | 0.48                          | 0.7                   | 2.3                     | flow into Basin B.2 in curb                   |
| B.2                                      | 23 | 1.29                      | 64                | 0.45                        | 0.63                          | 2.3                   | 6                       | includes flow from B.1                        |
| Sum B.1+B.2                              |    | 1.84                      |                   |                             |                               | 2.8                   | 7.5                     | To be added with (B.3+B.4)                    |
| Existing Flow from OS-1 (Merrick Report) |    | 1.62                      |                   |                             |                               | 5                     | 10.4                    |   |
| Total Sum OS-1 + B.1 + B.2               |    | 3.46                      |                   |                             |                               | 7.7                   | 16.8                    |   |
| B.3                                      | 24 | 0.73                      | 82                | 0.45                        | 0.63                          | 1.4                   | 3.7                     | flow into Basin B.4 in curb                   |
| B.4                                      | 25 | 0.71                      | 52                | 0.36                        | 0.63                          | 1.2                   | 3.9                     | includes flow from B.3                        |
| Sum B.3+B.4                              |    | 1.44                      |                   |                             |                               | 2.3                   | 6.5                     | To be added with (B.1+B.2)                    |
| Sum B.1-B.4                              |    | 0.14                      |                   |                             |                               | 9.8                   | 23.1                    | sum flow into exist. 10' type R               |

**APPENDIX C**

**Inlet Calculations**

**INLET CAPACITY CHART SUMP CONDITIONS**  
**AREA (TYPE C) INLET**

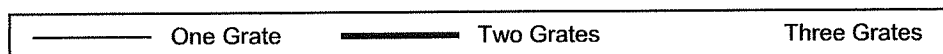
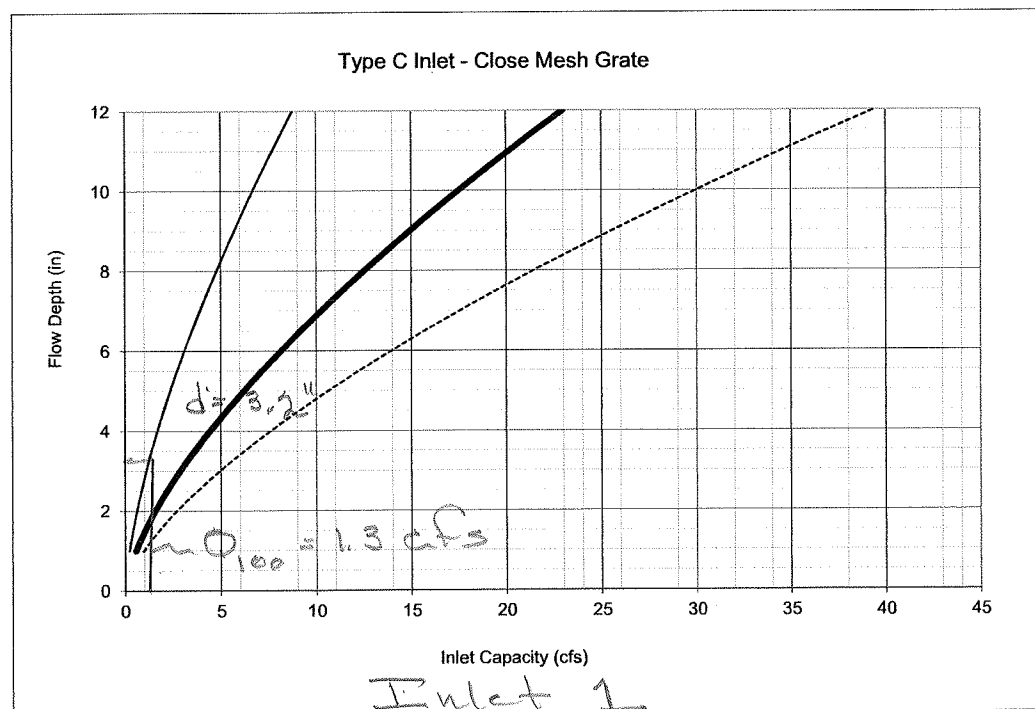
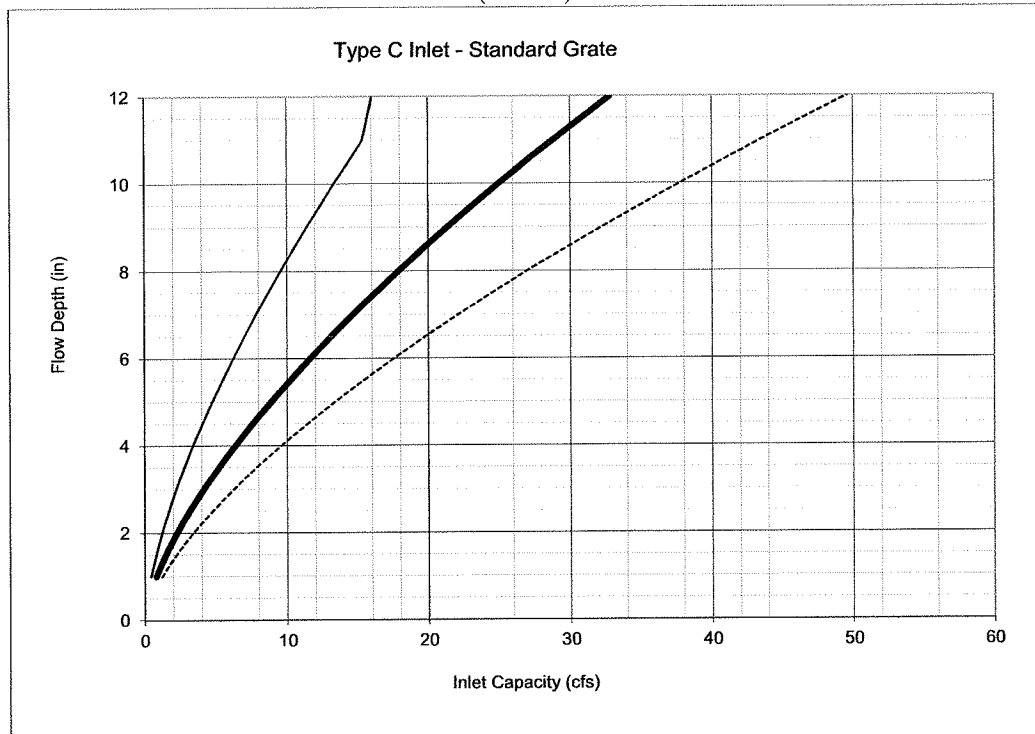

Note:

1. The Town of Parker standard inlet parameters must apply to use these charts. See the Roadway Manual.

$Q_s = 0.3 \text{ cfs}; d = 1\frac{1}{2}''$   
 $Q_{100} = 1.3 \text{ cfs}; d = 3\frac{1}{4}''$

**INLET CAPACITY CHART SUMP CONDITIONS**  
**AREA (TYPE C) INLET**

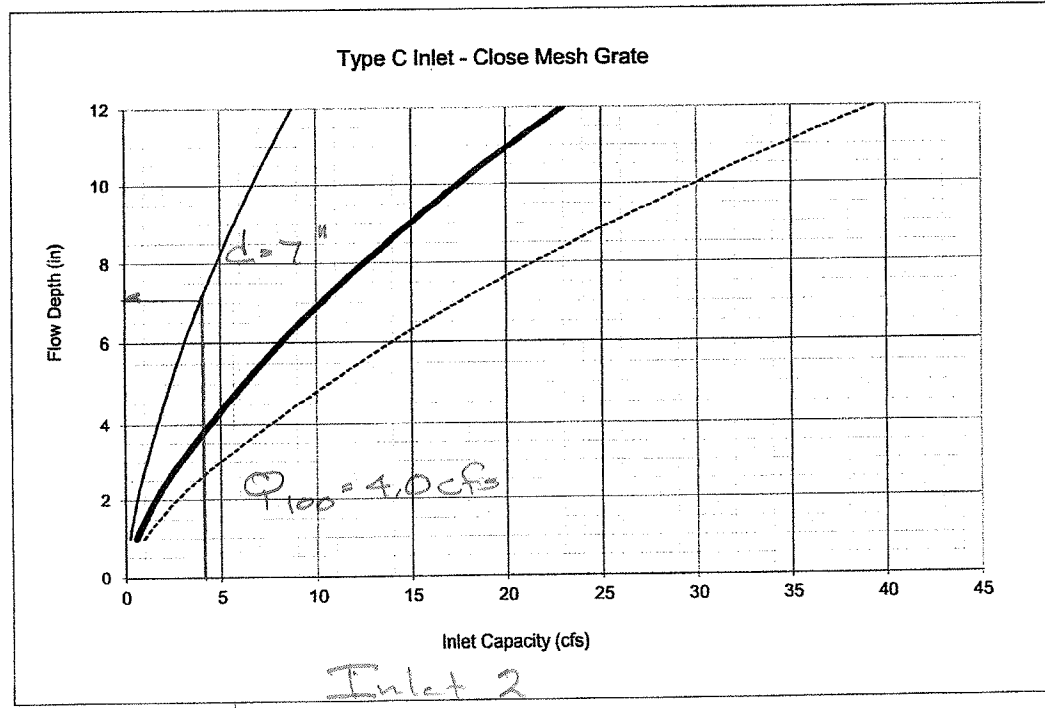
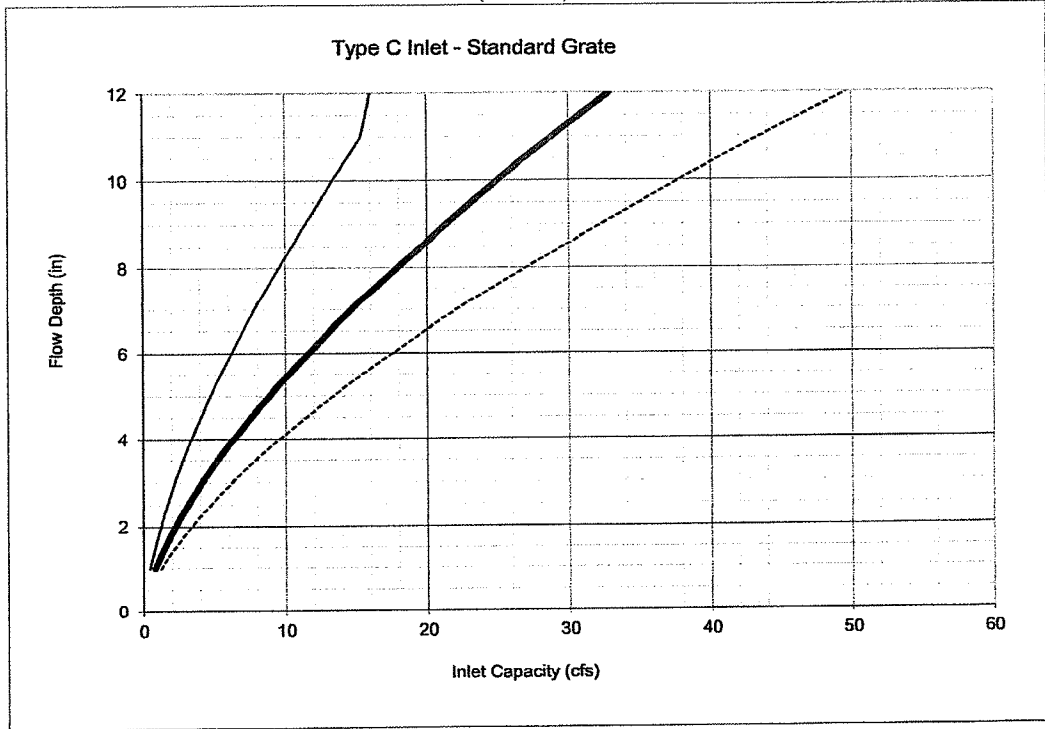

One Grate    
  Two Grates    
  Three Grates

Note:  
 1. The Town of Parker standard inlet parameters must apply to use these charts. See the Roadway Manual.

*Handwritten notes:*  
 $Q_5 = 1.25 \text{ cfs}; d = 3.1/4''$   
 $Q_{100} = 4.0 \text{ cfs}; d = 7''$   
 Assumes all up stream inlets are plugged.

**INLET CAPACITY CHART SUMP CONDITIONS**  
**AREA (TYPE C) INLET**

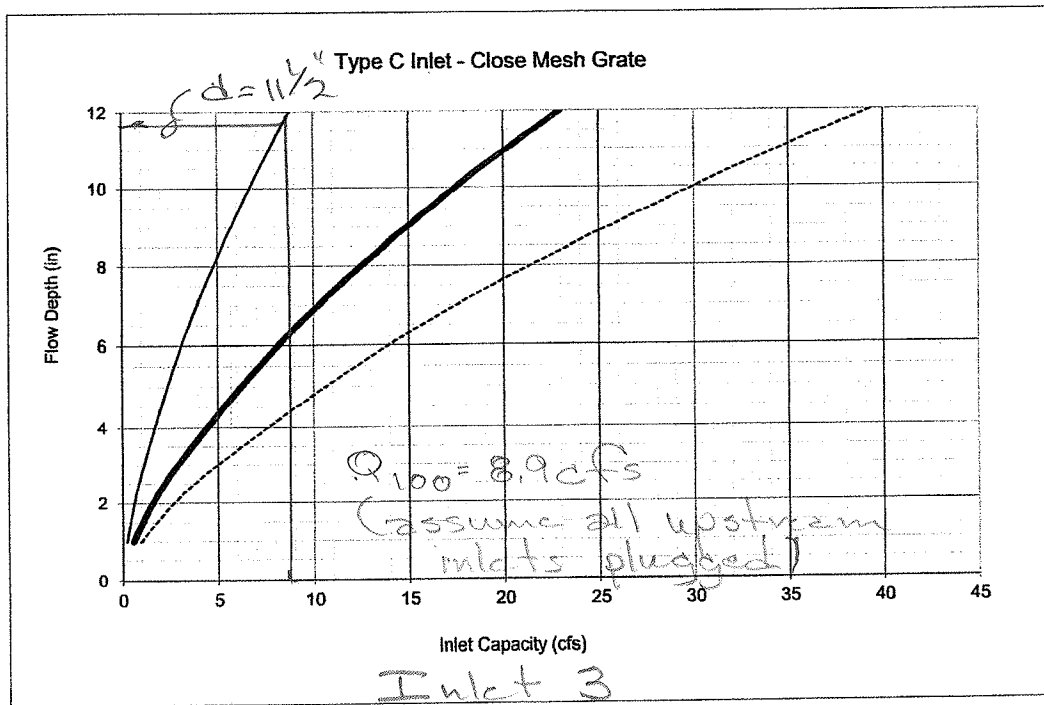
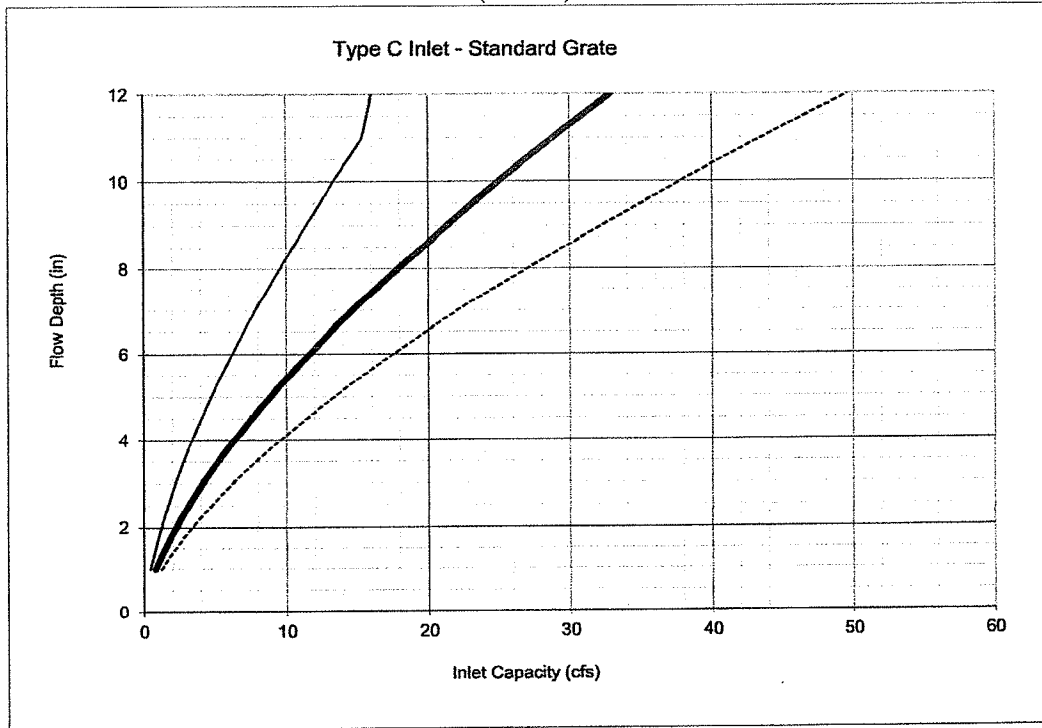

One Grate    
  Two Grates    
  Three Grates

Note:

1. The Town of Parker standard inlet parameters must apply to use these charts. See the Roadway Manual.

$Q_s = 3.0 \text{ cfs}; d = 6"$   
 $Q_{100} = 8.9 \text{ cfs}; d = 1\frac{1}{2}"$   
 Assumes all upstream inlets are plugged

**INLET CAPACITY CHART SUMP CONDITIONS**  
**CURB OPENING (TYPE R) INLET**

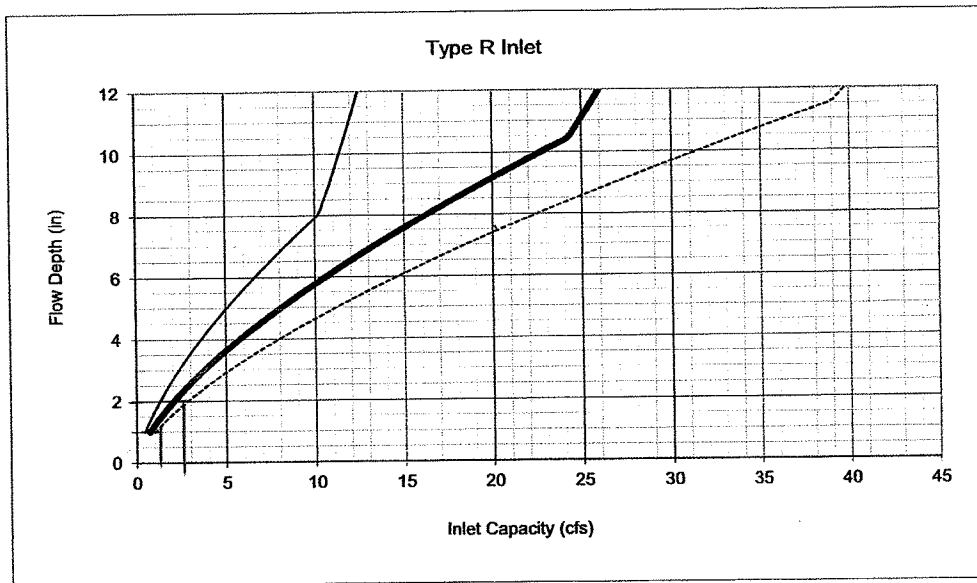

— 5' Inlet      — 10' Inlet      - - - 15' Inlet

Inlet 4  
 $Q_5 = 1.7 \text{ cfs}; d = 1\frac{1}{4}''$   
 $Q_{100} = 3.0 \text{ cfs}; d = 2''$

Note:

1. The Town of Parker standard inlet parameters must apply to use this chart. See the Roadway Manual.

**INLET CAPACITY CHART SUMP CONDITIONS**  
**CURB OPENING (TYPE R) INLET**

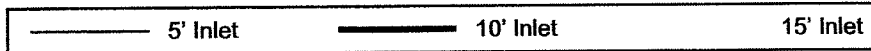
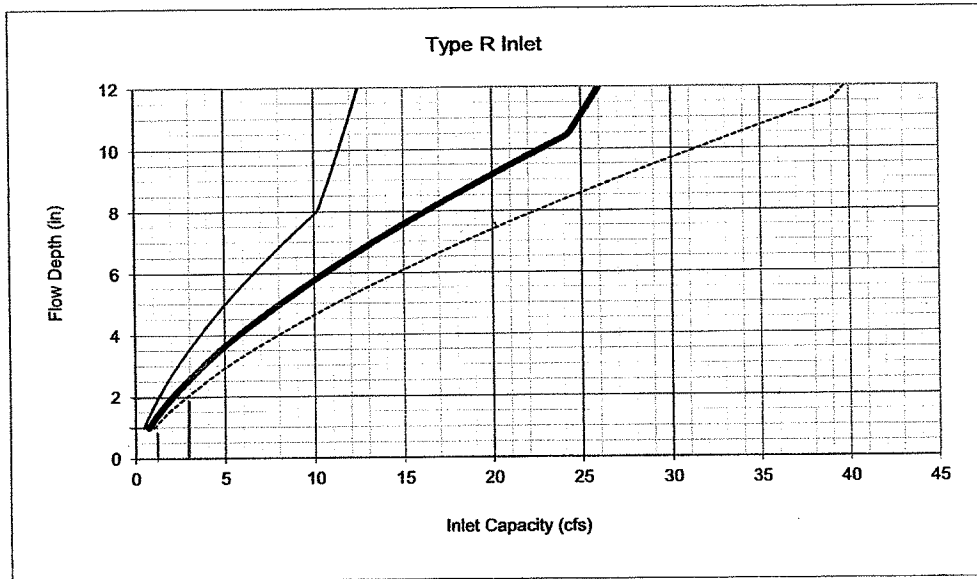

Inlet #5  
 $Q_5 = 1.4 \text{ cfs}; d = 1''$   
 $Q_{100} = 2.9 \text{ cfs}; d = 2''$

Note:

1. The Town of Parker standard inlet parameters must apply to use this chart. See the Roadway Manual.

**INLET CAPACITY CHART SUMP CONDITIONS**  
**CURB OPENING (TYPE R) INLET**

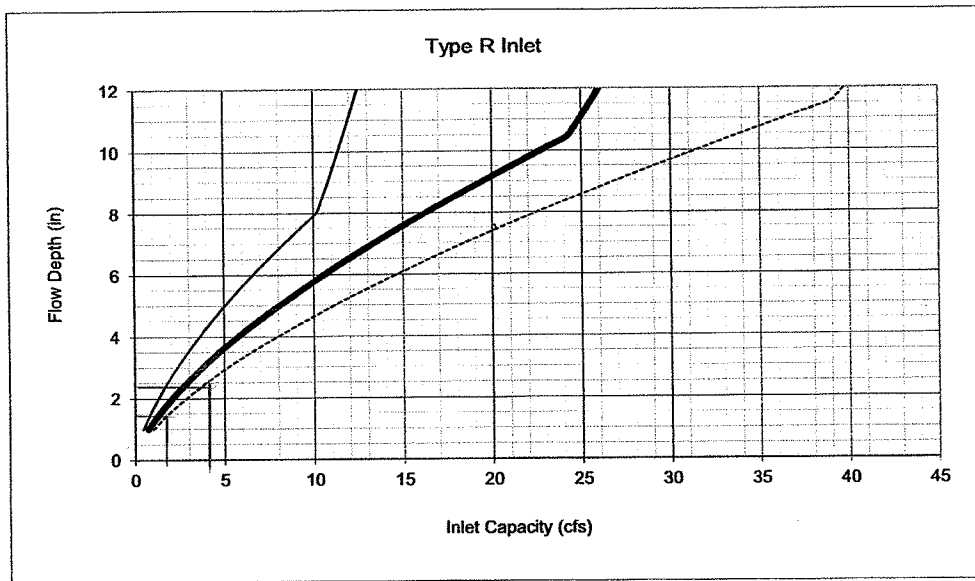

— 5' Inlet      — 10' Inlet      ····· 15' Inlet

Inlet 6  
 $Q_5 = 2.0 \text{ cfs}; d = 1\frac{1}{2}''$   
 $Q_{100} = 4.2 \text{ cfs}; d = 2\frac{1}{2}''$

Note:

1. The Town of Parker standard inlet parameters must apply to use this chart. See the Roadway Manual.

**INLET CAPACITY CHART SUMP CONDITIONS**  
**CURB OPENING (TYPE R) INLET**

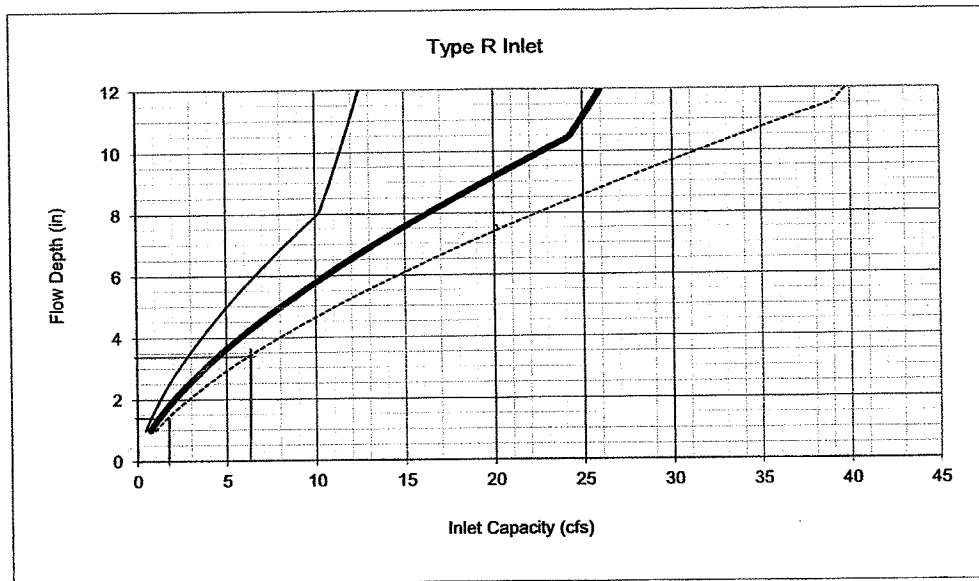

— 5' Inlet      — 10' Inlet      — 15' Inlet

Inlet 7  
 $Q_5 = 2.7 \text{ cfs}; d = 1\frac{1}{2}''$   
 $Q_{100} = 6.1 \text{ cfs}; d = 3\frac{1}{2}''$

Note:

1. The Town of Parker standard inlet parameters must apply to use this chart. See the Roadway Manual.

**INLET CAPACITY CHART SUMP CONDITIONS**  
CURB OPENING (TYPE R) INLET

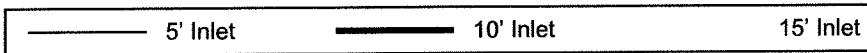
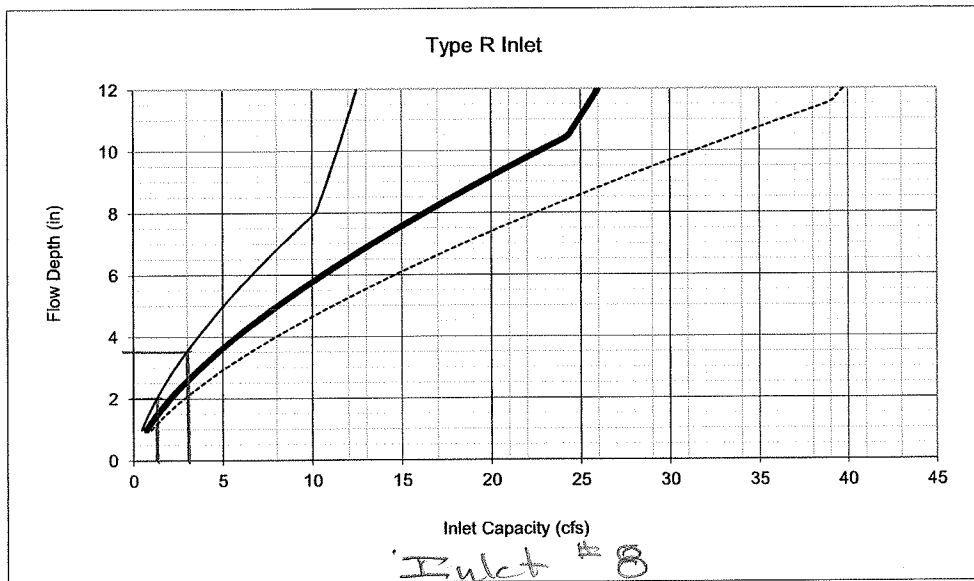

Inlet #8  
 $Q_5 = 1.3 \text{ cfs}; d = 2''$   
 $Q_{100} = 3.0 \text{ cfs}; d = 3\frac{1}{2}''$

Note:

1. The Town of Parker standard inlet parameters must apply to use this chart. See the Roadway Manual.

**INLET CAPACITY CHART SUMP CONDITIONS**  
**CURB OPENING (TYPE R) INLET**

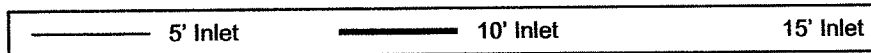
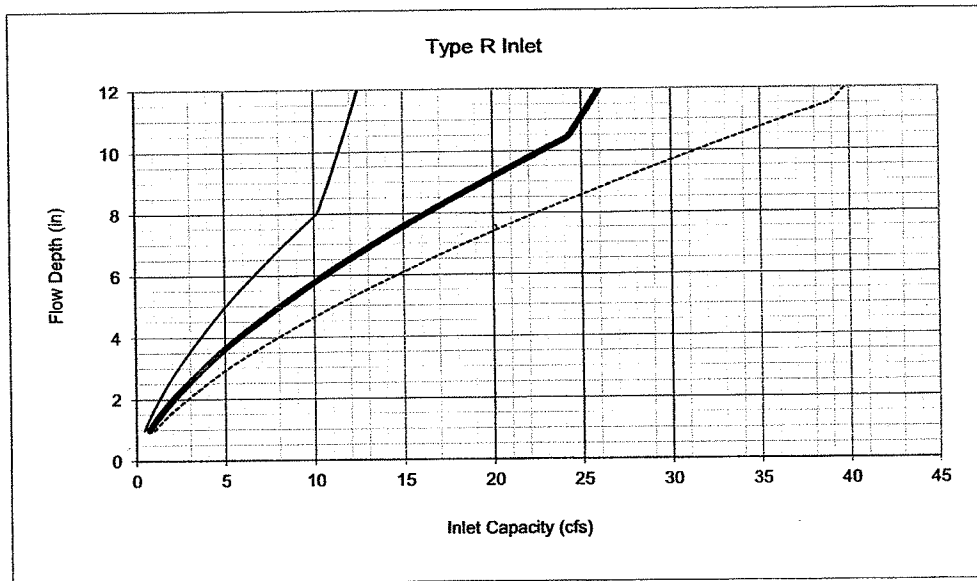

Inlet #9  
 $Q_5 = 0.2 \text{ cfs}; d = 1''$   
 $Q_{100} = 0.7 \text{ cfs}; d = 1''$

Note:

1. The Town of Parker standard inlet parameters must apply to use this chart. See the Roadway Manual.

**INLET CAPACITY CHART SUMP CONDITIONS**  
**CURB OPENING (TYPE R) INLET**

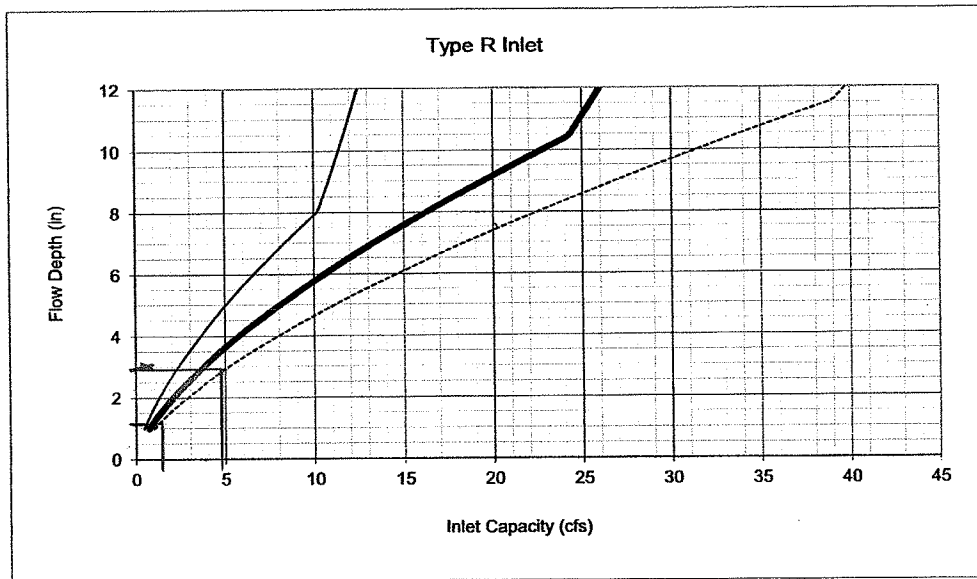

Inlet 10  
 $Q_5 = 2.2 \text{ cfs}; d = 1\frac{3}{4}''$   
 $Q_{100} = 4.8 \text{ cfs}; d = 3''$

Note:

1. The Town of Parker standard inlet parameters must apply to use this chart. See the Roadway Manual.

**INLET CAPACITY CHART SUMP CONDITIONS**  
CURB OPENING (TYPE R) INLET

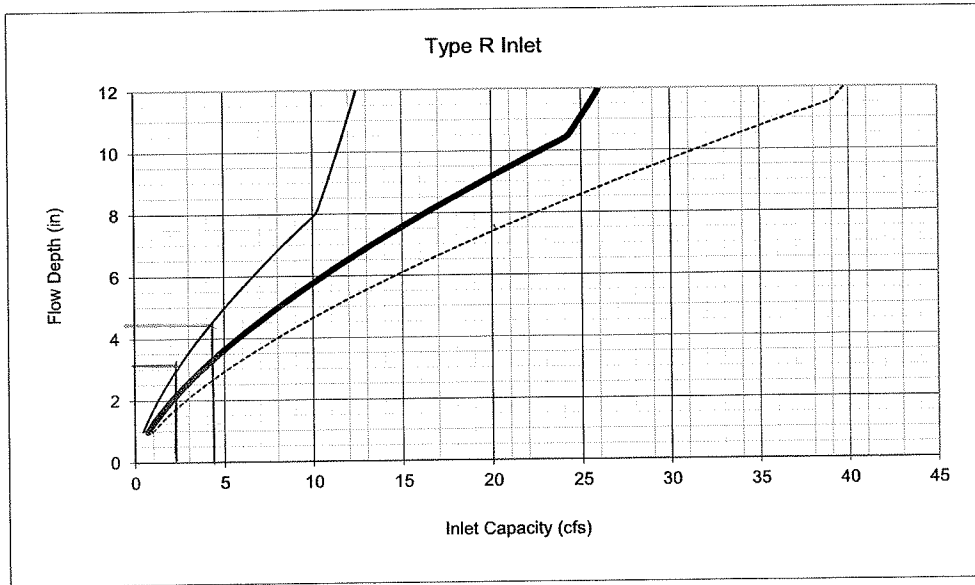

— 5' Inlet      — 10' Inlet      - - - 15' Inlet

Inlet #12  
 5 yr = 2.1 cfs; d = 3"  
 100 yr = 4.4 cfs; d = 4 1/2"

Note:

1. The Town of Parker standard inlet parameters must apply to use this chart. See the Roadway Manual.

**INLET CAPACITY CHART SUMP CONDITIONS**  
CURB OPENING (TYPE R) INLET

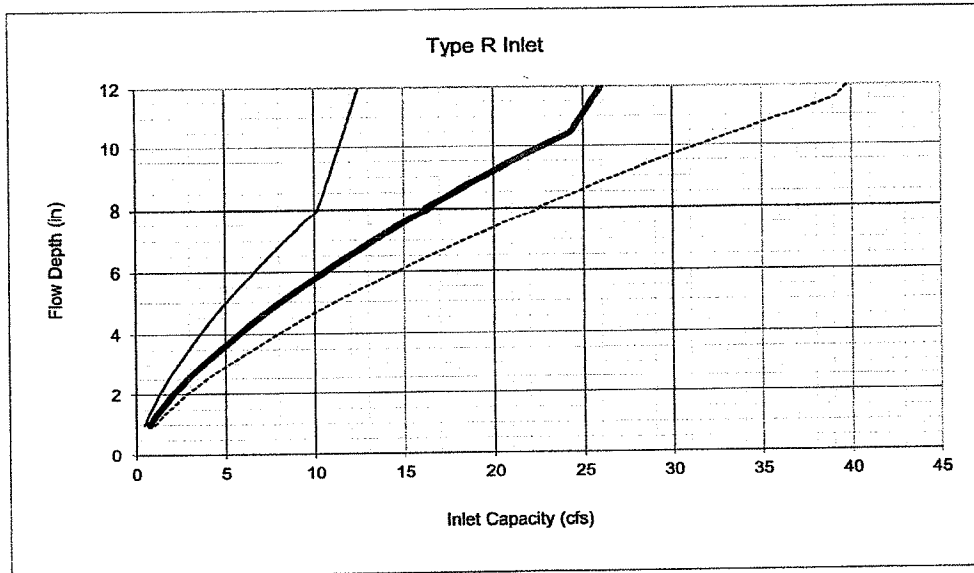

Inlet 13.

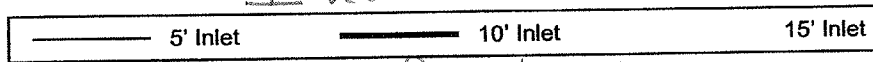

$Q_5 = 2.0 \text{ cfs}; d = 3''$   
 $Q_{100} = 4.2 \text{ cfs}; d = 4\frac{1}{2}''$

Note:

1. The Town of Parker standard inlet parameters must apply to use this chart. See the Roadway Manual.

### INLET CAPACITY CHART SUMP CONDITIONS CURB OPENING (TYPE R) INLET

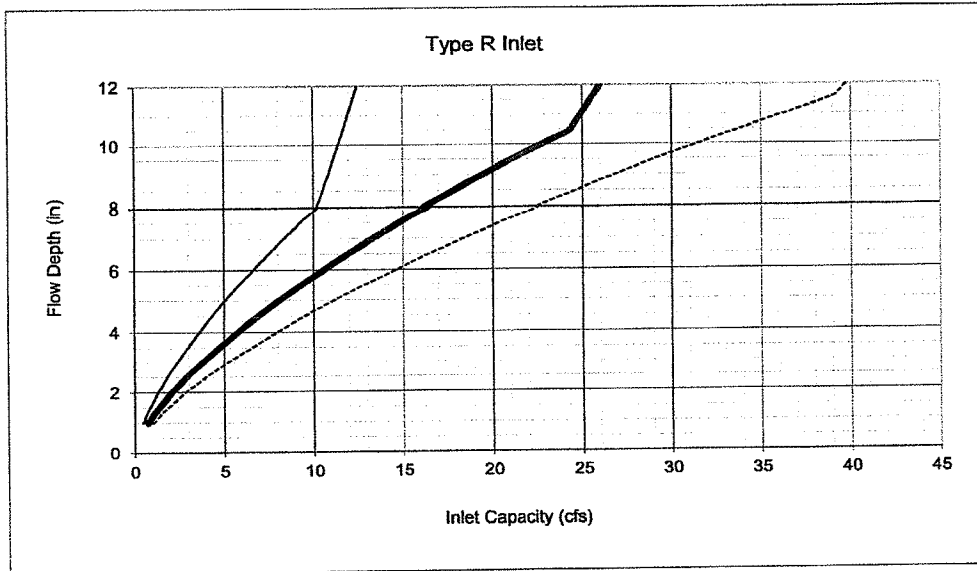

Inlet #15



$Q_5 = 1.5 \text{ cfs}; d = 2''$   
 $Q_{100} = 3.7 \text{ cfs}; d = 4''$

**Note:**

1. The Town of Parker standard inlet parameters must apply to use this chart. See the Roadway Manual.

**INLET CAPACITY CHART SUMP CONDITIONS**  
**CURB OPENING (TYPE R) INLET**

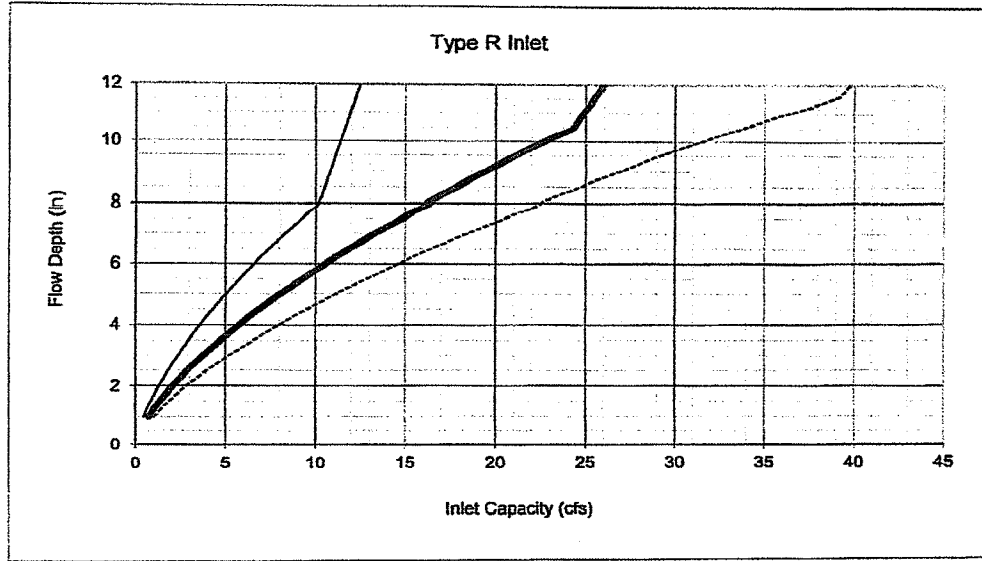

*Inlet 16*



$Q_5 = 1.5 \text{ cfs}; d = 2\frac{1}{4}''$   
 $Q_{100} = 3.7 \text{ cfs}; d = 4.1''$

**Note:**

1. The Town of Parker standard inlet parameters must apply to use this chart. See the Roadway Manual.

**INLET CAPACITY CHART SUMP CONDITIONS**  
**CURB OPENING (TYPE R) INLET**

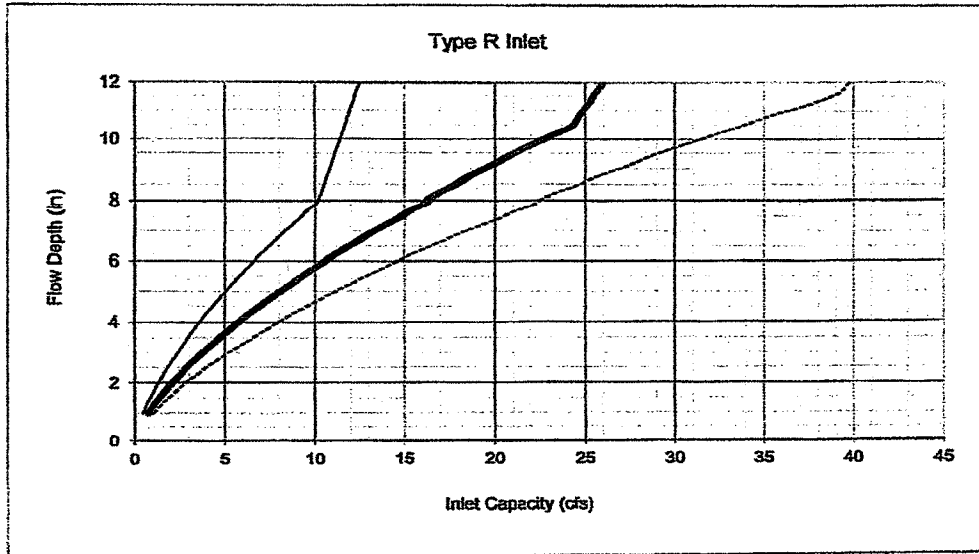

Inlet 17

— 5' Inlet      — 10' Inlet      — 15' Inlet

$Q_5 = 1.9 \text{ cfs}; d = 2\frac{3}{4}''$   
 $Q_{100} = 3.9 \text{ cfs}; d = 4\frac{1}{2}''$

Note:

1. The Town of Parker standard inlet parameters must apply to use this chart. See the Roadway Manual.

**INLET CAPACITY CHART SUMP CONDITIONS**  
**CURB OPENING (TYPE R) INLET**

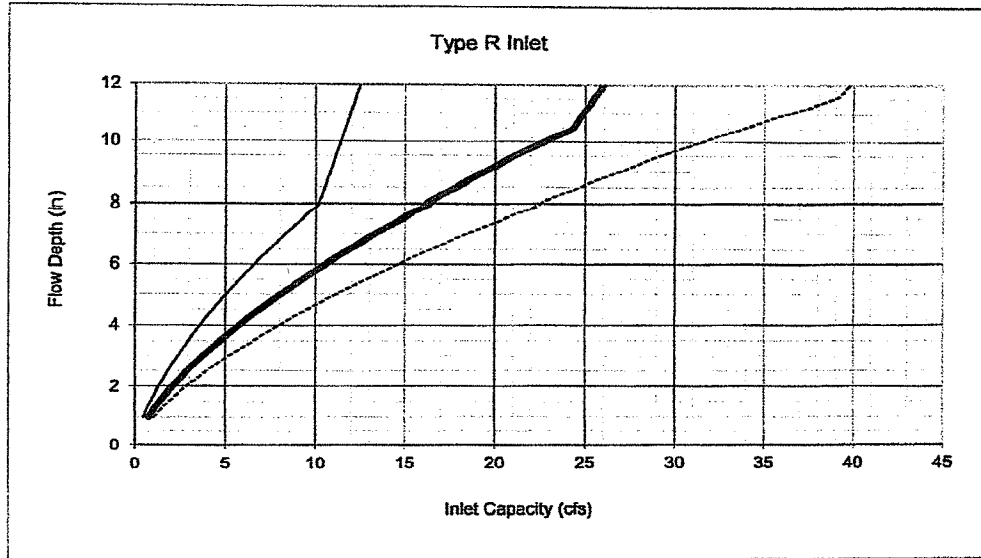

Existing 10' inlet



$Q_5 = 9.8 ; d = 5.6 \text{ inches}$

$Q_{100} = 23.1 ; d = 10.5 \text{ inches}$

Note:

1. The Town of Parker standard inlet parameters must apply to use this chart. See the Roadway Manual.

## ALLOWABLE CAPACITY FOR ONE-HALF OF STREET (Major & Minor Storm)

(Based on Regulated Criteria for Maximum Allowable Flow Depth and Spread)

Project: Boondocks - Cottonwood Dr.  
 Inlet ID: \_\_\_\_\_

**street capacity calculations with Merrick calculations for Cottonwood Only**

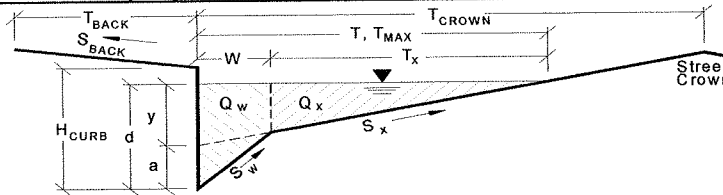

### Gutter Geometry (Enter data in the blue cells)

Maximum Allowable Width for Spread Behind Curb

Side Slope Behind Curb (leave blank for no conveyance credit behind curb)

Manning's Roughness Behind Curb

|            |   |        |                       |
|------------|---|--------|-----------------------|
| $T_{BACK}$ | = | 5.0    | ft                    |
| $S_{BACK}$ | = | 0.0200 | ft. vert. / ft. horiz |
| $n_{BACK}$ | = | 0.0300 |                       |

Height of Curb at Gutter Flow Line

Distance from Curb Face to Street Crown

Gutter Depression

Gutter Width

Street Transverse Slope

Street Longitudinal Slope - Enter 0 for sump condition

Manning's Roughness for Street Section

|              |   |        |                       |
|--------------|---|--------|-----------------------|
| $H_{CURB}$   | = | 6.00   | inches                |
| $T_{CROWN}$  | = | 30.0   | ft                    |
| $a$          | = | 2.00   | inches                |
| $W$          | = | 2.00   | ft                    |
| $S_x$        | = | 0.0200 | ft. vert. / ft. horiz |
| $S_o$        | = | 0.0125 | ft. vert. / ft. horiz |
| $n_{STREET}$ | = | 0.0200 |                       |

Max. Allowable Water Spread for Minor & Major Storm

Max. Allowable Depth at Gutter Flow Line for Minor & Major Storm

Allow Flow Depth at Street Crown (leave blank for no)

|           | Minor Storm | Major Storm |         |
|-----------|-------------|-------------|---------|
| $T_{MAX}$ | 30.0        | 30.0        | ft      |
| $d_{MAX}$ | 5.10        | 6.20        | inches  |
|           |             |             | X = yes |

### Maximum Gutter Capacity Based On Allowable Water Spread

Gutter Cross Slope (Eq. ST-8)

Water Depth without Gutter Depression (Eq. ST-2)

Water Depth with a Gutter Depression

Allowable Spread for Discharge outside the Gutter Section  $W$  ( $T - W$ )

Gutter Flow to Design Flow Ratio by FHWA HEC-22 method (Eq. ST-7)

Discharge outside the Gutter Section  $W$ , carried in Section  $T_x$

Discharge within the Gutter Section  $W$  ( $Q_T - Q_x$ )

Discharge Behind the Curb (e.g., sidewalk, driveways, & lawns)

### Maximum Flow Based On Allowable Water Spread

Flow Velocity Within the Gutter Section

$V \cdot d$  Product: Flow Velocity Times Gutter Flowline Depth

|             | Minor Storm | Major Storm |        |
|-------------|-------------|-------------|--------|
| $S_w$       | 0.1033      | 0.1033      | ft/ft  |
| $y$         | 7.20        | 7.20        | inches |
| $d$         | 9.20        | 9.20        | inches |
| $T_x$       | 28.0        | 28.0        | ft     |
| $E_o$       | 0.202       | 0.202       |        |
| $Q_x$       | 33.3        | 33.3        | cfs    |
| $Q_w$       | 8.5         | 8.5         | cfs    |
| $Q_{BACK}$  | 2.2         | 2.2         | cfs    |
| $Q_T$       | 44.0        | 44.0        | cfs    |
| $V$         | 6.4         | 6.4         | fps    |
| $V \cdot d$ | 4.9         | 4.9         |        |

### Maximum Gutter Capacity Based on Allowable Gutter Depth

Theoretical Water Spread

Theoretical Spread for Discharge outside the Gutter Section  $W$  ( $T - W$ )

Gutter Flow to Design Flow Ratio by FHWA HEC-22 method (Eq. ST-7)

Theoretical Discharge outside the Gutter Section  $W$ , carried in Section  $T_{xTH}$

Actual Discharge outside the Gutter Section  $W$ , (limited by distance  $T_{CROWN}$ )

Discharge within the Gutter Section  $W$  ( $Q_d - Q_x$ )

Discharge Behind the Curb (e.g., sidewalk, driveways, & lawns)

### Total Discharge for Major & Minor Storm

Flow Velocity Within the Gutter Section

$V \cdot d$  Product: Flow Velocity Times Gutter Flowline Depth

Slope-Based Depth Safety Reduction Factor for Major & Minor ( $d \geq 6"$ ) Storm

### Max Flow Based on Allow. Gutter Depth (Safety Factor Applied)

Resultant Flow Depth at Gutter Flowline (Safety Factor Applied)

Resultant Flow Depth at Street Crown (Safety Factor Applied)

|             | Minor Storm | Major Storm |        |
|-------------|-------------|-------------|--------|
| $T_{TH}$    | 12.9        | 17.5        | ft     |
| $T_{xTH}$   | 10.9        | 15.5        | ft     |
| $E_o$       | 0.487       | 0.360       |        |
| $Q_{xTH}$   | 2.7         | 6.9         | cfs    |
| $Q_x$       | 2.7         | 6.9         | cfs    |
| $Q_w$       | 2.6         | 3.9         | cfs    |
| $Q_{BACK}$  | 0.0         | 0.0         | cfs    |
| $Q$         | 5.3         | 10.8        | cfs    |
| $V$         | 4.0         | 4.7         | fps    |
| $V \cdot d$ | 1.7         | 2.4         |        |
| $R$         | 1.00        | 1.00        |        |
| $Q_d$       | 5.3         | 10.8        | cfs    |
| $d$         | 5.10        | 6.20        | inches |
| $d_{CROWN}$ | 0.00        | 0.00        | inches |

### Max. Allowable Gutter Capacity Based on Minimum of $Q_T$ or $Q_d$

|             | Minor Storm | Major Storm |     |
|-------------|-------------|-------------|-----|
| $Q_{allow}$ | 5.3         | 10.8        | cfs |

## ALLOWABLE CAPACITY FOR ONE-HALF OF STREET (Major & Minor Storm)

(Based on Regulated Criteria for Maximum Allowable Flow Depth and Spread)

Project:  
Inlet ID:

**Boondocks - Cottonwood Dr.**

**street capacity calculations with Boondocks**

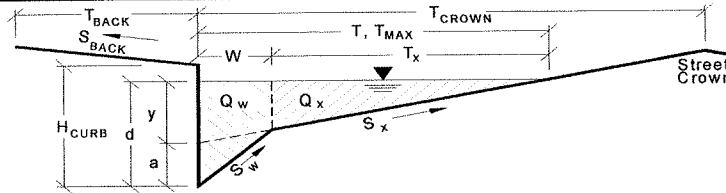

### Gutter Geometry (Enter data in the blue cells)

Maximum Allowable Width for Spread Behind Curb

Side Slope Behind Curb (leave blank for no conveyance credit behind curb)

Manning's Roughness Behind Curb

Height of Curb at Gutter Flow Line

Distance from Curb Face to Street Crown

Gutter Depression

Gutter Width

Street Transverse Slope

Street Longitudinal Slope - Enter 0 for sump condition

Manning's Roughness for Street Section

|            |   |        |                       |
|------------|---|--------|-----------------------|
| $T_{BACK}$ | = | 5.0    | ft                    |
| $S_{BACK}$ | = | 0.0200 | ft. vert. / ft. horiz |
| $n_{BACK}$ | = | 0.0300 |                       |

|              |   |        |                       |
|--------------|---|--------|-----------------------|
| $H_{CURB}$   | = | 6.00   | inches                |
| $T_{CROWN}$  | = | 30.0   | ft                    |
| $a$          | = | 2.00   | inches                |
| $W$          | = | 2.00   | ft                    |
| $S_x$        | = | 0.0200 | ft. vert. / ft. horiz |
| $S_o$        | = | 0.0125 | ft. vert. / ft. horiz |
| $n_{STREET}$ | = | 0.0200 |                       |

Max. Allowable Water Spread for Minor & Major Storm

Max. Allowable Depth at Gutter Flow Line for Minor & Major Storm

Allow Flow Depth at Street Crown (leave blank for no)

|           | Minor Storm | Major Storm |         |
|-----------|-------------|-------------|---------|
| $T_{MAX}$ | 30.0        | 30.0        | ft      |
| $d_{MAX}$ | 5.65        | 6.95        | inches  |
|           |             |             | X = yes |

### Maximum Gutter Capacity Based On Allowable Water Spread

Gutter Cross Slope (Eq. ST-8)

Water Depth without Gutter Depression (Eq. ST-2)

Water Depth with a Gutter Depression

Allowable Spread for Discharge outside the Gutter Section  $W$  ( $T - W$ )

Gutter Flow to Design Flow Ratio by FHWA HEC-22 method (Eq. ST-7)

Discharge outside the Gutter Section  $W$ , carried in Section  $T_x$

Discharge within the Gutter Section  $W$  ( $Q_T - Q_x$ )

Discharge Behind the Curb (e.g., sidewalk, driveways, & lawns)

Maximum Flow Based On Allowable Water Spread

Flow Velocity Within the Gutter Section

$V \cdot d$  Product: Flow Velocity Times Gutter Flowline Depth

|             | Minor Storm | Major Storm |        |
|-------------|-------------|-------------|--------|
| $S_w$       | 0.1033      | 0.1033      | ft/ft  |
| $y$         | 7.20        | 7.20        | inches |
| $d$         | 9.20        | 9.20        | inches |
| $T_x$       | 28.0        | 28.0        | ft     |
| $E_o$       | 0.202       | 0.202       |        |
| $Q_x$       | 33.3        | 33.3        | cfs    |
| $Q_w$       | 8.5         | 8.5         | cfs    |
| $Q_{BACK}$  | 2.2         | 2.2         | cfs    |
| $Q_T$       | 44.0        | 44.0        | cfs    |
| $V$         | 6.4         | 6.4         | fps    |
| $V \cdot d$ | 4.9         | 4.9         |        |

### Maximum Gutter Capacity Based on Allowable Gutter Depth

Theoretical Water Spread

Theoretical Spread for Discharge outside the Gutter Section  $W$  ( $T - W$ )

Gutter Flow to Design Flow Ratio by FHWA HEC-22 method (Eq. ST-7)

Theoretical Discharge outside the Gutter Section  $W$ , carried in Section  $T_{xTH}$

Actual Discharge outside the Gutter Section  $W$ , (limited by distance  $T_{CROWN}$ )

Discharge within the Gutter Section  $W$  ( $Q_d - Q_x$ )

Discharge Behind the Curb (e.g., sidewalk, driveways, & lawns)

Total Discharge for Major & Minor Storm

Flow Velocity Within the Gutter Section

$V \cdot d$  Product: Flow Velocity Times Gutter Flowline Depth

Slope-Based Depth Safety Reduction Factor for Major & Minor ( $d \geq 6"$ ) Storm

Max Flow Based on Allow. Gutter Depth (Safety Factor Applied)

Resultant Flow Depth at Gutter Flowline (Safety Factor Applied)

Resultant Flow Depth at Street Crown (Safety Factor Applied)

|             | Minor Storm | Major Storm |        |
|-------------|-------------|-------------|--------|
| $T_{TH}$    | 15.2        | 20.6        | ft     |
| $T_{xTH}$   | 13.2        | 18.6        | ft     |
| $E_o$       | 0.415       | 0.303       |        |
| $Q_{xTH}$   | 4.5         | 11.2        | cfs    |
| $Q_x$       | 4.5         | 11.2        | cfs    |
| $Q_w$       | 3.2         | 4.9         | cfs    |
| $Q_{BACK}$  | 0.0         | 0.1         | cfs    |
| $Q$         | 7.7         | 16.2        | cfs    |
| $V$         | 4.3         | 5.1         | fps    |
| $V \cdot d$ | 2.0         | 3.0         |        |
| $R$         | 1.00        | 1.00        |        |
| $Q_d$       | 7.7         | 16.3        | cfs    |
| $d$         | 5.65        | 6.95        | inches |
| $d_{CROWN}$ | 0.00        | 0.00        | inches |

Max. Allowable Gutter Capacity Based on Minimum of  $Q_T$  or  $Q_d$

|             | Minor Storm | Major Storm |     |
|-------------|-------------|-------------|-----|
| $Q_{allow}$ | 7.7         | 16.3        | cfs |

**APPENDIX D**

**Storm Sewer Hydraulic Calculations**

**STORM DRAINAGE SYSTEM DESIGN  
(RATIONAL METHOD PROCEDURE)**

**MM&D Engineering Services, Inc.**

Calculated by WEM  
Date 11/7/2014  
Revised I = (28.5P<sup>1.49</sup>)/(10+tc)<sup>0.786</sup>

Job num. 13-343  
Project Boondocks & Commercial Property  
Design Storm 5 year I = 1.39

| STREET                                | DESIGN POINT | AREA DESIGN (acre)                              | AREA RUNOFF COEF. | DIRECT RUNOFF |             |       | TOTAL RUNOFF |                   |       | COMMENTS  |
|---------------------------------------|--------------|---|-------------------|---------------|-------------|-------|--------------|-------------------|-------|---|
|                                       |              |   |                   | tc min.       | C * A in/hr | Q cfs | tc min.      | C * A (sum) in/hr | Q cfs |   |
| <b>Developed Basins</b>               |              |   |                   |               |             |       |              |                   |       |   |
| <b>DP 1 through 6</b>                 |              | Sum AC = AC(DP 1 - DP 6) = 2.17                 |                   |               |             |       |              |                   |       | Tc = Longest Tc (DP 2) + travel = 11.9 + 433/3 fps = 14.3 |
| <b>5 year runoff</b>                  |              |   |                   |               |             |       |              |                   |       |   |
| <b>Total Flow into existing storm</b> |              |   |                   |               |             |       |              |                   |       |   |
|                                       |              | 14.3  | 2.17              | 3.2           | 7.0         |       |              |                   |       |   |
| <b>Pipe from 9 to 10</b>              |              | Sum AC = AC(DP 8 - DP 9) = 0.87                 |                   |               |             |       |              |                   |       | Tc = Longest Tc (DP 9) = 10.3                             |
|                                       |              | 10.3  | 0.87              | 3.7           | 3.2         |       |              |                   |       |   |
| <b>Pipe from 10 to 11</b>             |              | Sum AC = AC(DP 9 + DP 10) = 0.87 + 0.95 = 0.92  |                   |               |             |       |              |                   |       | Tc = Longest Tc (DP 9) + travel = 10.3 + 45/3fps = 10.6   |
|                                       |              | 10.6  | 0.92              | 3.7           | 3.4         |       |              |                   |       |   |
| <b>Pipe from 11 to 12</b>             |              | Sum AC = AC(DP 10 + DP 11) = 0.92 + 0.12 = 1.04 |                   |               |             |       |              |                   |       | Tc = Longest Tc (DP 10) + travel = 10.6 + 155/3fps = 11.5 |
|                                       |              | 11.5  | 1.04              | 3.6           | 3.7         |       |              |                   |       |   |
| <b>Pipe from 11 to 12</b>             |              | Sum AC = AC(DP 11 + DP 12) = 1.04 + 0.45 = 1.49 |                   |               |             |       |              |                   |       | Tc = Longest Tc (DP 11) + travel = 11.5 + 120/3fps = 12.2 |
|                                       |              | 12.2  | 1.49              | 3.5           | 5.2         |       |              |                   |       |   |
| <b>Pipe from 12 to 13</b>             |              | Sum AC = AC(DP 12) = 1.49                       |                   |               |             |       |              |                   |       | Tc = Longest Tc (DP 12) + travel = 12.2 + 100/3fps = 12.7 |
|                                       |              | 12.7  | 1.49              | 3.4           | 5.1         |       |              |                   |       |   |
| <b>Pipe from 15 to 13</b>             |              | Sum AC = AC(DP 15) = 0.44                       |                   |               |             |       |              |                   |       | Tc = Longest Tc (DP 15) + travel = 6.0 + 45/3fps = 6.3    |
|                                       |              | 6.3   | 0.44              | 4.4           | 1.9         |       |              |                   |       |   |
| <b>Pipe from 13 to 16</b>             |              | Sum AC = AC(DP 15 + DP 12) = 0.44 + 1.49 = 1.93 |                   |               |             |       |              |                   |       | Tc = Longest Tc (DP 13) + travel = 12.7 + 150/3fps = 13.5 |
|                                       |              | 13.5  | 1.93              | 3.3           | 6.4         |       |              |                   |       |   |

**STORM DRAINAGE SYSTEM DESIGN  
(RATIONAL METHOD PROCEDURE)**

**MM&D Engineering Services, Inc.**

Calculated by WEM  
Date 11/07/14  
Revised I = (28.5P)/(10+tc) = 0.786

Job num. 13-343  
Project Boondocks & Commercial Property  
Design Storm 5 year I = 1.39

| STREET                                | DESIGN POINT | AREA DESIGN (acre)  | AREA RUNOFF COEF. | DIRECT RUNOFF |             |       | TOTAL RUNOFF |                   |       | COMMENTS   |
|---------------------------------------|--------------|---|-------------------|---------------|-------------|-------|--------------|-------------------|-------|--|
|                                       |              |   |                   | tc min.       | C * A in/hr | Q cfs | tc min.      | C * A (sum) in/hr | Q cfs |  |
| <b>Developed Basins</b>               |              |   |                   |               |             |       |              |                   |       |  |
| 5 year runoff                         |              |   |                   |               |             |       |              |                   |       |  |
| <b>Pipe from 16 to 17</b>             |              | Sum AC = AC(DP 13 + DP 16) = 1.93 + 0.35 = 2.28               |                   | 14.2          | 2.28        | 3.2   | 7.4          |                   |       | Tc = Longest Tc (DP 15) + travel = 13.5 + 130/3fps = 14.2  |
| <b>Pipe from 17 to 17A</b>            |              | Sum AC = AC(DP 16 + DP 18) = 2.28 + 0.32 = 2.60               |                   | 14.6          | 2.60        | 3.2   | 8.3          |                   |       | Tc = Longest Tc (DP 17) + travel = 14.2 + 76/3fps = 14.6   |
| <b>Pipe from 7 to 17A</b>             |              | Sum AC = AC(DP 7) = 0.18                                      |                   | 5.3           | 0.18        | 4.6   | 0.8          |                   |       | Tc = Longest Tc (DP 7) + travel = 5 + 55/3fps = 5.3        |
| <b>Pipe from 17A to 17B</b>           |              | Sum AC = AC(DP 17A + DP17) = 0.18 + 2.60 = 2.78               |                   | 15.5          | 2.78        | 3.1   | 8.6          |                   |       | Tc = Longest Tc (DP 17A) + travel = 14.6 + 158/3fps = 15.5 |
| <b>Pipe from 19 to 18</b>             |              | Sum AC = AC(DP 19) = 0.32                                     |                   | 5.3           | 0.32        | 4.6   | 1.5          |                   |       | Tc = Longest Tc (DP 19) + travel = 5 + 55/3fps = 5.3       |
| <b>Pipe from 18 to 17B</b>            |              | Sum AC = AC(DP 19 + DP18) = 0.32 + 0.40 = 0.72                |                   | 5.9           | 0.72        | 4.5   | 3.2          |                   |       | Tc = Longest Tc (DP 18) + travel = 5.3 + 105/3fps = 5.9    |
| <b>Total Flow to existing 42" RCP</b> |              | Sum AC = AC(DP 17A to 17B + DP18 to 17B) = 0.72 + 2.78 = 3.50 |                   | 15.7          | 3.50        | 3.1   | 10.8         |                   |       | Tc = Longest Tc (DP 17B) + travel = 15.5 + 42/3fps = 15.7  |

**STORM DRAINAGE SYSTEM DESIGN  
(RATIONAL METHOD PROCEDURE)**

**MM&D Engineering Services, Inc.**

Calculated by WEM

Date 11/7/2014

Revised I = (28.5P)/(10+tc)^0.786

Job num. 13-343  
Project Boondocks & Commercial Property  
Design Storm 100 year I = 2.6

| STREET                                | DESIGN POINT | AREA DESIGN                                      | AREA (acre) | RUNOFF COEF. | DIRECT RUNOFF |       |         | TOTAL RUNOFF |       |         | COMMENTS  |
|---------------------------------------|--------------|--|-------------|--------------|---------------|-------|---------|--------------|-------|---------|---|
|                                       |              |  |             |              | tc min.       | C * A | I in/hr | tc min.      | C * A | I in/hr |   |
| <b>Developed Basins</b>               |              |  |             |              |               |       |         |              |       |         |   |
| <b>DP 1 through 6</b>                 |              | Sum AC = AC(DP 1 - DP 6) = 3.16                  |             |              |               |       |         |              |       |         | Tc = Longest Tc (DP 2) + travel = 11.9 + 433/3 fps= 14.3  |
| <b>Total Flow into existing storm</b> |              |  |             |              |               |       |         |              |       |         |   |
| <b>Pipe from 9 to 10</b>              |              | Sum AC = AC(DP 8 - DP 9) = 1.04                  |             |              | 14.3          | 3.16  | 6.0     | 19.1         |       |         |   |
|                                       |              |  |             |              | 10.3          | 1.04  | 7.0     | 7.2          |       |         | Tc = Longest Tc (DP 9) = 10.3                             |
| <b>Pipe from 10 to 11</b>             |              | Sum AC = AC(DP 9 + DP10) = 1.04 + 0.07 = 1.11    |             |              | 10.6          | 1.11  | 6.9     | 7.6          |       |         | Tc = Longest Tc (DP 9) + travel = 10.3 + 45/3fps = 10.6   |
| <b>Pipe from 11 to 12</b>             |              | Sum AC = AC(DP 10 + DP11) = 1.11 + 0.19 = 1.30   |             |              | 11.5          | 1.30  | 6.6     | 8.6          |       |         | Tc = Longest Tc (DP 10) + travel = 10.6 + 155/3fps = 11.5 |
| <b>Pipe from 11 to 12</b>             |              | Sum AC = AC(DP 11 + DP12) = 1.30 + 0.49 = 1.79   |             |              | 12.2          | 1.79  | 6.5     | 11.6         |       |         | Tc = Longest Tc (DP 11) + travel = 11.5 + 120/3fps = 12.2 |
| <b>Pipe from 12 to 13</b>             |              | Sum AC = AC(DP 12 ) = 1.79                       |             |              | 12.7          | 1.79  | 6.4     | 11.4         |       |         | Tc = Longest Tc (DP 12) + travel = 12.2 + 100/3fps = 12.7 |
| <b>Pipe from 15 to 13</b>             |              | Sum AC = AC(DP 15 ) = 0.44                       |             |              | 6.3           | 0.44  | 8.3     | 3.6          |       |         | Tc = Longest Tc (DP 15) + travel = 6.0 + 45/3fps = 6.3    |
| <b>Pipe from 13 to 16</b>             |              | Sum AC = AC(DP 15 + DP 12 ) = 0.44 + 1.78 = 2.22 |             |              | 13.5          | 2.22  | 6.2     | 13.8         |       |         | Tc = Longest Tc (DP 13) + travel = 12.7 + 150/3fps = 13.5 |

**STORM DRAINAGE SYSTEM DESIGN  
(RATIONAL METHOD PROCEDURE)**

**MM&D Engineering Services, Inc.**

Calculated by WEM  
Date 11/07/14  
Revised I = (28.5P)<sup>1/3</sup> / (10+tc)<sup>0.786</sup>

Job num. 13-343  
Project Boondocks & Commercial Property  
Design Storm 100 year I = 2.6

| STREET POINT | DESIGN AREA | AREA DESIGN (acre) | DIRECT RUNOFF |       |     | TOTAL RUNOFF |             |         | COMMENTS |
|--------------|-------------|--------------------|---------------|-------|-----|--------------|-------------|---------|----------|
|              |             |                    | COEF.         | in/hr | cfs | tc min.      | C * A (sum) | I in/hr |          |

**Developed Basins**

100 year runoff

**Pipe from 16 to 17** Sum AC = AC(DP 13 + DP 16) = 2.22 + 0.35 = 2.57 Tc = Longest Tc (DP 15) + travel = 13.5 + 130/3fps = 14.2

14.2 2.57 6.1 15.6

**Pipe from 17 to 17A** Sum AC = AC(DP 16 + DP 18) = 2.58 + 0.32 = 2.80 Tc = Longest Tc (DP 17) + travel = 14.2 + 76/3fps = 14.6

14.6 2.80 6.0 16.7

**Pipe from 7 to 17A** Sum AC = AC(DP 7) = 0.20 Tc = Longest Tc (DP 7) + travel = 5 + 55/3fps = 5.3

5.3 0.20 8.7 1.7

**Pipe from 17A to 17B** Sum AC = AC(DP 17A + DP17) = 0.20 + 2.80 = 3.00 Tc = Longest Tc (DP 17A) + travel = 14.6 + 158/3fps = 15.5

15.5 3.00 5.8 17.4

**Pipe from 19 to 18** Sum AC = AC(DP 19) = 0.36 Tc = Longest Tc (DP 19) + travel = 5 + 55/3fps = 5.3

5.3 0.36 8.7 3.1

**Pipe from 18 to 17B** Sum AC = AC(DP 19 + DP18) = 0.36 + 0.32 = 0.68 Tc = Longest Tc (DP 18) + travel = 5.3 + 105/3fps = 5.9

5.9 0.68 8.4 5.7

**Total Flow to existing 42" RCP**

Sum AC = AC(DP 17A to 17B + DP18 to 17B) = 0.68 + 3.00 = 3.68  
 15.7 3.68 5.8 21.3 Tc = Longest Tc (DP 17B) + travel = 15.5 + 42/3fps = 15.7

# Circular Pipe Flow

Project: **Boondocks**  
 Pipe ID: **DP 8 to DP 9**

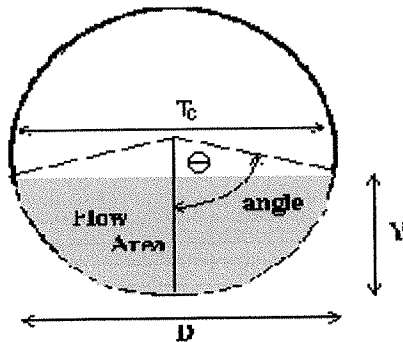

### Design Information (Input)

|                         |                         |                       |
|-------------------------|-------------------------|-----------------------|
| Pipe Invert Slope       | $S_o =$                 | <u>0.0068</u> ft/ft   |
| Pipe Manning's n-value  | $n =$                   | <u>0.0130</u>         |
| Pipe Diameter           | $D =$                   | <u>18.00</u> inches   |
| <b>Design discharge</b> | <b><math>Q =</math></b> | <b><u>7.2</u> cfs</b> |

### Full-flow Capacity (Calculated)

|                            |                           |                       |
|----------------------------|---------------------------|-----------------------|
| Full-flow area             | $A_f =$                   | <u>1.77</u> sq ft     |
| Full-flow wetted perimeter | $P_f =$                   | <u>4.71</u> ft        |
| Half Central Angle         | $\theta =$                | <u>3.14</u> rad       |
| <b>Full-flow capacity</b>  | <b><math>Q_f =</math></b> | <b><u>8.7</u> cfs</b> |

### Calculation of Normal Flow Condition

|  |                            |                       |
|--|----------------------------|-----------------------|
| Half Central Angle ( $0 < \theta < 3.14$ ) | $\theta =$                 | <u>1.97</u> rad       |
| Flow area                                  | $A_n =$                    | <u>1.31</u> sq ft     |
| Top width                                  | $T_n =$                    | <u>1.38</u> ft        |
| Wetted perimeter                           | $P_n =$                    | <u>2.96</u> ft        |
| Flow depth                                 | $Y_n =$                    | <u>1.04</u> ft        |
| Flow velocity                              | $V_n =$                    | <u>5.49</u> fps       |
| <b>Discharge</b>                           | <b><math>Q_n =</math></b>  | <b><u>7.2</u> cfs</b> |
| <b>Normal Depth Froude Number</b>          | <b><math>Fr_n =</math></b> | <b><u>0.99</u></b>    |

### Calculation of Critical Flow Condition

|  |                            |                    |
|--|----------------------------|--------------------|
| Half Central Angle ( $0 < \theta_c < 3.14$ ) | $\theta_c =$               | <u>1.97</u> rad    |
| Critical flow area                           | $A_c =$                    | <u>1.31</u> sq ft  |
| Critical top width                           | $T_c =$                    | <u>1.38</u> ft     |
| Critical flow depth                          | $Y_c =$                    | <u>1.04</u> ft     |
| Critical flow velocity                       | $V_c =$                    | <u>5.51</u> fps    |
| <b>Critical Depth Froude Number</b>          | <b><math>Fr_c =</math></b> | <b><u>1.00</u></b> |

# Circular Pipe Flow

Project: **Boondocks**  
 Pipe ID: **DP 9 to DP 10**

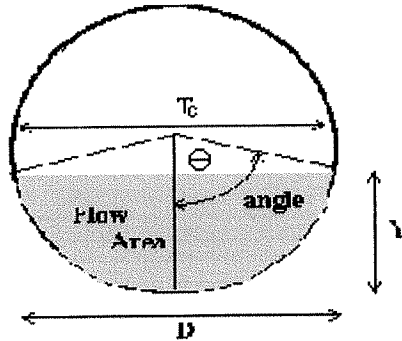

| <b>Design Information (Input)</b>             |                                     |
|---|-------------------------------------|
| Pipe Invert Slope                             | So = <u>0.0068</u> ft/ft            |
| Pipe Manning's n-value                        | n = <u>0.0130</u>                   |
| Pipe Diameter                                 | D = <u>18.00</u> inches             |
| <b>Design discharge</b>                       | <b>Q = <u>7.2</u> cfs</b>           |
| <b>Full-flow Capacity (Calculated)</b>        |                                     |
| Full-flow area                                | Af = <u>1.77</u> sq ft              |
| Full-flow wetted perimeter                    | Pf = <u>4.71</u> ft                 |
| Half Central Angle                            | Theta = <u>3.14</u> rad             |
| <b>Full-flow capacity</b>                     | <b>Qf = <u>8.7</u> cfs</b>          |
| <b>Calculation of Normal Flow Condition</b>   |                                     |
| Half Central Angle (0<Theta<3.14)             | Theta = <u>1.97</u> rad             |
| Flow area                                     | An = <u>1.31</u> sq ft              |
| Top width                                     | Tn = <u>1.38</u> ft                 |
| Wetted perimeter                              | Pn = <u>2.96</u> ft                 |
| Flow depth                                    | Yn = <u>1.04</u> ft                 |
| Flow velocity                                 | Vn = <u>5.49</u> fps                |
| <b>Discharge</b>                              | <b>Qn = <u>7.2</u> cfs</b>          |
| <b>Normal Depth Froude Number</b>             | <b>Fr<sub>n</sub> = <u>0.99</u></b> |
| <b>Calculation of Critical Flow Condition</b> |                                     |
| Half Central Angle (0<Theta-c<3.14)           | Theta-c = <u>1.97</u> rad           |
| Critical flow area                            | Ac = <u>1.31</u> sq ft              |
| Critical top width                            | Tc = <u>1.38</u> ft                 |
| Critical flow depth                           | Yc = <u>1.04</u> ft                 |
| Critical flow velocity                        | Vc = <u>5.51</u> fps                |
| <b>Critical Depth Froude Number</b>           | <b>Fr<sub>c</sub> = <u>1.00</u></b> |

# Circular Pipe Flow

Project: **Boondocks**  
 Pipe ID: **DP 10 to DP 11**

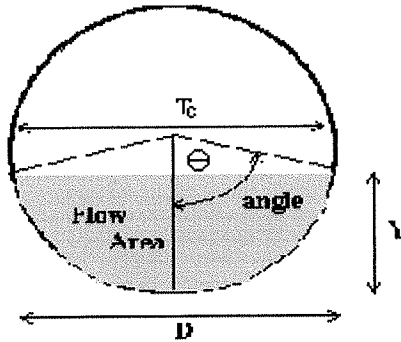

|   |                                     |
|---|-------------------------------------|
| <b>Design Information (Input)</b>             |                                     |
| Pipe Invert Slope                             | So = <u>0.0068</u> ft/ft            |
| Pipe Manning's n-value                        | n = <u>0.0130</u>                   |
| Pipe Diameter                                 | D = <u>18.00</u> inches             |
| <b>Design discharge</b>                       | <b>Q = <u>7.6</u> cfs</b>           |
| <b>Full-flow Capacity (Calculated)</b>        |                                     |
| Full-flow area                                | Af = <u>1.77</u> sq ft              |
| Full-flow wetted perimeter                    | Pf = <u>4.71</u> ft                 |
| Half Central Angle                            | Theta = <u>3.14</u> rad             |
| <b>Full-flow capacity</b>                     | <b>Qf = <u>8.7</u> cfs</b>          |
| <b>Calculation of Normal Flow Condition</b>   |                                     |
| Half Central Angle ( $0 < \theta < 3.14$ )    | Theta = <u>2.04</u> rad             |
| Flow area                                     | An = <u>1.37</u> sq ft              |
| Top width                                     | Tn = <u>1.34</u> ft                 |
| Wetted perimeter                              | Pn = <u>3.06</u> ft                 |
| Flow depth                                    | Yn = <u>1.09</u> ft                 |
| Flow velocity                                 | Vn = <u>5.54</u> fps                |
| <b>Discharge</b>                              | <b>Qn = <u>7.6</u> cfs</b>          |
| <b>Normal Depth Froude Number</b>             | <b>Fr<sub>n</sub> = <u>0.97</u></b> |
| <b>Calculation of Critical Flow Condition</b> |                                     |
| Half Central Angle ( $0 < \theta_c < 3.14$ )  | Theta-c = <u>2.01</u> rad           |
| Critical flow area                            | Ac = <u>1.35</u> sq ft              |
| Critical top width                            | Tc = <u>1.36</u> ft                 |
| Critical flow depth                           | Yc = <u>1.07</u> ft                 |
| Critical flow velocity                        | Vc = <u>5.65</u> fps                |
| <b>Critical Depth Froude Number</b>           | <b>Fr<sub>c</sub> = <u>1.00</u></b> |

0.7

# Circular Pipe Flow

Project: **Boondocks**  
 Pipe ID: **DP 11 to DP 12**

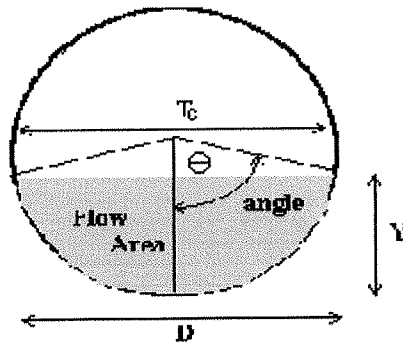

| <b>Design Information (Input)</b>             |                                     |
|---|-------------------------------------|
| Pipe Invert Slope                             | So = <u>0.0068</u> ft/ft            |
| Pipe Manning's n-value                        | n = <u>0.0130</u>                   |
| Pipe Diameter                                 | D = <u>18.00</u> inches             |
| <b>Design discharge</b>                       | <b>Q = <u>8.6</u> cfs</b>           |
| <b>Full-flow Capacity (Calculated)</b>        |                                     |
| Full-flow area                                | Af = <u>1.77</u> sq ft              |
| Full-flow wetted perimeter                    | Pf = <u>4.71</u> ft                 |
| Half Central Angle                            | Theta = <u>3.14</u> rad             |
| <b>Full-flow capacity</b>                     | <b>Qf = <u>8.7</u> cfs</b>          |
| <b>Calculation of Normal Flow Condition</b>   |                                     |
| Half Central Angle (0<Theta<3.14)             | Theta = <u>2.24</u> rad             |
| Flow area                                     | An = <u>1.54</u> sq ft              |
| Top width                                     | Tn = <u>1.17</u> ft                 |
| Wetted perimeter                              | Pn = <u>3.36</u> ft                 |
| Flow depth                                    | Yn = <u>1.22</u> ft                 |
| Flow velocity                                 | Vn = <u>5.60</u> fps                |
| <b>Discharge</b>                              | <b>Qn = <u>8.6</u> cfs</b>          |
| <b>Normal Depth Froude Number</b>             | <b>Fr<sub>n</sub> = <u>0.86</u></b> |
| <b>Calculation of Critical Flow Condition</b> |                                     |
| Half Central Angle (0<Theta-c<3.14)           | Theta-c = <u>2.11</u> rad           |
| Critical flow area                            | Ac = <u>1.44</u> sq ft              |
| Critical top width                            | Tc = <u>1.29</u> ft                 |
| Critical flow depth                           | Yc = <u>1.14</u> ft                 |
| Critical flow velocity                        | Vc = <u>5.99</u> fps                |
| <b>Critical Depth Froude Number</b>           | <b>Fr<sub>c</sub> = <u>1.00</u></b> |

0.8

# Circular Pipe Flow

Project: **Boondocks**

Pipe ID: **DP 11 to DP 12A**

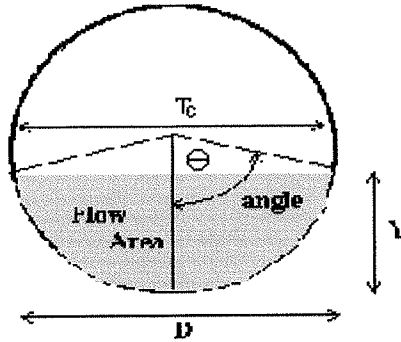

### Design Information (Input)

|                         |                         |                        |
|-------------------------|-------------------------|------------------------|
| Pipe Invert Slope       | $S_o =$                 | <u>0.0160</u> ft/ft    |
| Pipe Manning's n-value  | $n =$                   | <u>0.0130</u>          |
| Pipe Diameter           | $D =$                   | <u>18.00</u> inches    |
| <b>Design discharge</b> | <b><math>Q =</math></b> | <b><u>11.6</u> cfs</b> |

### Full-flow Capacity (Calculated)

|                            |                           |                        |
|----------------------------|---------------------------|------------------------|
| Full-flow area             | $A_f =$                   | <u>1.77</u> sq ft      |
| Full-flow wetted perimeter | $P_f =$                   | <u>4.71</u> ft         |
| Half Central Angle         | $\theta =$                | <u>3.14</u> rad        |
| <b>Full-flow capacity</b>  | <b><math>Q_f =</math></b> | <b><u>13.3</u> cfs</b> |

### Calculation of Normal Flow Condition

|  |                            |                        |
|--|----------------------------|------------------------|
| Half Central Angle ( $0 < \theta < 3.14$ ) | $\theta =$                 | <u>2.03</u> rad        |
| Flow area                                  | $A_n =$                    | <u>1.37</u> sq ft      |
| Top width                                  | $T_n =$                    | <u>1.34</u> ft         |
| Wetted perimeter                           | $P_n =$                    | <u>3.05</u> ft         |
| Flow depth                                 | $Y_n =$                    | <u>1.08</u> ft         |
| Flow velocity                              | $V_n =$                    | <u>8.49</u> fps        |
| <b>Discharge</b>                           | <b><math>Q_n =</math></b>  | <b><u>11.6</u> cfs</b> |
| <b>Normal Depth Froude Number</b>          | <b><math>Fr_n =</math></b> | <b><u>1.48</u></b>     |

### Calculation of Critical Flow Condition

|  |                            |                    |
|--|----------------------------|--------------------|
| Half Central Angle ( $0 < \theta_c < 3.14$ ) | $\theta_c =$               | <u>2.39</u> rad    |
| Critical flow area                           | $A_c =$                    | <u>1.62</u> sq ft  |
| Critical top width                           | $T_c =$                    | <u>1.03</u> ft     |
| Critical flow depth                          | $Y_c =$                    | <u>1.30</u> ft     |
| Critical flow velocity                       | $V_c =$                    | <u>7.14</u> fps    |
| <b>Critical Depth Froude Number</b>          | <b><math>Fr_c =</math></b> | <b><u>1.00</u></b> |

D,9

# Circular Pipe Flow

Project: **Boondocks**

Pipe ID: **DP 15 to DP 13**

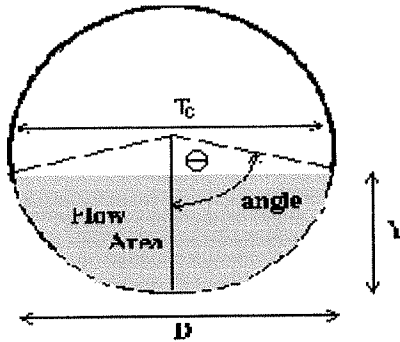

### Design Information (Input)

|                         |                         |                       |
|-------------------------|-------------------------|-----------------------|
| Pipe Invert Slope       | $S_o =$                 | <u>0.0040</u> ft/ft   |
| Pipe Manning's n-value  | $n =$                   | <u>0.0130</u>         |
| Pipe Diameter           | $D =$                   | <u>18.00</u> inches   |
| <b>Design discharge</b> | <b><math>Q =</math></b> | <b><u>3.6</u> cfs</b> |

### Full-flow Capacity (Calculated)

|                            |                           |                       |
|----------------------------|---------------------------|-----------------------|
| Full-flow area             | $A_f =$                   | <u>1.77</u> sq ft     |
| Full-flow wetted perimeter | $P_f =$                   | <u>4.71</u> ft        |
| Half Central Angle         | $\theta =$                | <u>3.14</u> rad       |
| <b>Full-flow capacity</b>  | <b><math>Q_f =</math></b> | <b><u>6.7</u> cfs</b> |

### Calculation of Normal Flow Condition

|  |                            |                       |
|--|----------------------------|-----------------------|
| Half Central Angle ( $0 < \theta < 3.14$ ) | $\theta =$                 | <u>1.62</u> rad       |
| Flow area                                  | $A_n =$                    | <u>0.94</u> sq ft     |
| Top width                                  | $T_n =$                    | <u>1.50</u> ft        |
| Wetted perimeter                           | $P_n =$                    | <u>2.43</u> ft        |
| Flow depth                                 | $Y_n =$                    | <u>0.79</u> ft        |
| Flow velocity                              | $V_n =$                    | <u>3.84</u> fps       |
| <b>Discharge</b>                           | <b><math>Q_n =</math></b>  | <b><u>3.6</u> cfs</b> |
| <b>Normal Depth Froude Number</b>          | <b><math>Fr_n =</math></b> | <b><u>0.86</u></b>    |

### Calculation of Critical Flow Condition

|  |                            |                    |
|--|----------------------------|--------------------|
| Half Central Angle ( $0 < \theta_c < 3.14$ ) | $\theta_c =$               | <u>1.54</u> rad    |
| Critical flow area                           | $A_c =$                    | <u>0.85</u> sq ft  |
| Critical top width                           | $T_c =$                    | <u>1.50</u> ft     |
| Critical flow depth                          | $Y_c =$                    | <u>0.72</u> ft     |
| Critical flow velocity                       | $V_c =$                    | <u>4.26</u> fps    |
| <b>Critical Depth Froude Number</b>          | <b><math>Fr_c =</math></b> | <b><u>1.00</u></b> |

D.10

## Circular Pipe Flow

Project: **Boondocks**

Pipe ID: **DP 13 to DP 16**

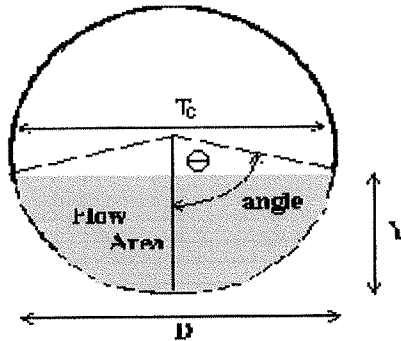

### Design Information (Input)

|                         |                         |                        |
|-------------------------|-------------------------|------------------------|
| Pipe Invert Slope       | $S_o =$                 | <u>0.0200</u> ft/ft    |
| Pipe Manning's n-value  | $n =$                   | <u>0.0130</u>          |
| Pipe Diameter           | $D =$                   | <u>18.00</u> inches    |
| <b>Design discharge</b> | <b><math>Q =</math></b> | <b><u>13.8</u> cfs</b> |

### Full-flow Capacity (Calculated)

|                            |                           |                        |
|----------------------------|---------------------------|------------------------|
| Full-flow area             | $A_f =$                   | <u>1.77</u> sq ft      |
| Full-flow wetted perimeter | $P_f =$                   | <u>4.71</u> ft         |
| Half Central Angle         | $\theta =$                | <u>3.14</u> rad        |
| <b>Full-flow capacity</b>  | <b><math>Q_f =</math></b> | <b><u>14.9</u> cfs</b> |

### Calculation of Normal Flow Condition

|  |                            |                        |
|--|----------------------------|------------------------|
| Half Central Angle ( $0 < \theta < 3.14$ ) | $\theta =$                 | <u>2.12</u> rad        |
| Flow area                                  | $A_n =$                    | <u>1.44</u> sq ft      |
| Top width                                  | $T_n =$                    | <u>1.28</u> ft         |
| Wetted perimeter                           | $P_n =$                    | <u>3.18</u> ft         |
| Flow depth                                 | $Y_n =$                    | <u>1.14</u> ft         |
| Flow velocity                              | $V_n =$                    | <u>9.57</u> fps        |
| <b>Discharge</b>                           | <b><math>Q_n =</math></b>  | <b><u>13.8</u> cfs</b> |
| <b>Normal Depth Froude Number</b>          | <b><math>Fr_n =</math></b> | <b><u>1.59</u></b>     |

### Calculation of Critical Flow Condition

|  |                            |                    |
|--|----------------------------|--------------------|
| Half Central Angle ( $0 < \theta_c < 3.14$ ) | $\theta_c =$               | <u>2.56</u> rad    |
| Critical flow area                           | $A_c =$                    | <u>1.70</u> sq ft  |
| Critical top width                           | $T_c =$                    | <u>0.83</u> ft     |
| Critical flow depth                          | $Y_c =$                    | <u>1.38</u> ft     |
| Critical flow velocity                       | $V_c =$                    | <u>8.13</u> fps    |
| <b>Critical Depth Froude Number</b>          | <b><math>Fr_c =</math></b> | <b><u>1.00</u></b> |

# Circular Pipe Flow

Project: **Boondocks**

Pipe ID: **DP 16 to DP 17**

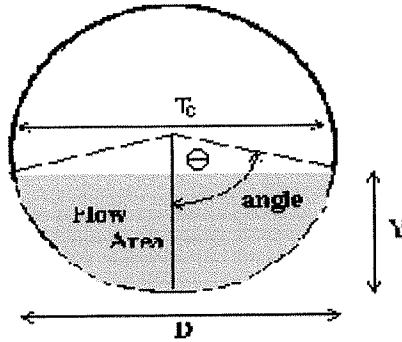

### Design Information (Input)

|                         |                         |                        |
|-------------------------|-------------------------|------------------------|
| Pipe Invert Slope       | $S_o =$                 | <u>0.0240</u> ft/ft    |
| Pipe Manning's n-value  | $n =$                   | <u>0.0130</u>          |
| Pipe Diameter           | $D =$                   | <u>18.00</u> inches    |
| <b>Design discharge</b> | <b><math>Q =</math></b> | <b><u>15.6</u> cfs</b> |

### Full-flow Capacity (Calculated)

|                            |                           |                        |
|----------------------------|---------------------------|------------------------|
| Full-flow area             | $A_f =$                   | <u>1.77</u> sq ft      |
| Full-flow wetted perimeter | $P_f =$                   | <u>4.71</u> ft         |
| Half Central Angle         | $\theta =$                | <u>3.14</u> rad        |
| <b>Full-flow capacity</b>  | <b><math>Q_f =</math></b> | <b><u>16.3</u> cfs</b> |

### Calculation of Normal Flow Condition

|  |                            |                        |
|--|----------------------------|------------------------|
| Half Central Angle ( $0 < \theta < 3.14$ ) | $\theta =$                 | <u>2.17</u> rad        |
| Flow area                                  | $A_n =$                    | <u>1.48</u> sq ft      |
| Top width                                  | $T_n =$                    | <u>1.24</u> ft         |
| Wetted perimeter                           | $P_n =$                    | <u>3.26</u> ft         |
| Flow depth                                 | $Y_n =$                    | <u>1.17</u> ft         |
| Flow velocity                              | $V_n =$                    | <u>10.51</u> fps       |
| <b>Discharge</b>                           | <b><math>Q_n =</math></b>  | <b><u>15.6</u> cfs</b> |
| <b>Normal Depth Froude Number</b>          | <b><math>Fr_n =</math></b> | <b><u>1.69</u></b>     |

### Calculation of Critical Flow Condition

|  |                            |                    |
|--|----------------------------|--------------------|
| Half Central Angle ( $0 < \theta_c < 3.14$ ) | $\theta_c =$               | <u>2.67</u> rad    |
| Critical flow area                           | $A_c =$                    | <u>1.73</u> sq ft  |
| Critical top width                           | $T_c =$                    | <u>0.68</u> ft     |
| Critical flow depth                          | $Y_c =$                    | <u>1.42</u> ft     |
| Critical flow velocity                       | $V_c =$                    | <u>9.02</u> fps    |
| <b>Critical Depth Froude Number</b>          | <b><math>Fr_c =</math></b> | <b><u>1.00</u></b> |

# Circular Pipe Flow

Project: **Boondocks**

Pipe ID: **DP 17 to DP 17A**

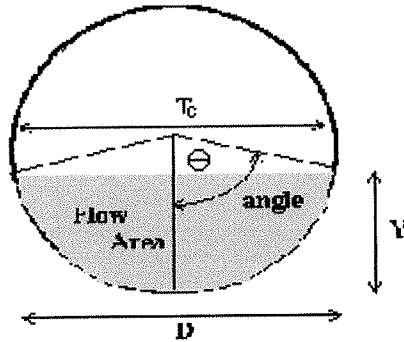

### Design Information (Input)

|                         |                         |                        |
|-------------------------|-------------------------|------------------------|
| Pipe Invert Slope       | $S_o =$                 | <u>0.0260</u> ft/ft    |
| Pipe Manning's n-value  | $n =$                   | <u>0.0130</u>          |
| Pipe Diameter           | $D =$                   | <u>18.00</u> inches    |
| <b>Design discharge</b> | <b><math>Q =</math></b> | <b><u>16.7</u> cfs</b> |

### Full-flow Capacity (Calculated)

|                            |                           |                        |
|----------------------------|---------------------------|------------------------|
| Full-flow area             | $A_f =$                   | <u>1.77</u> sq ft      |
| Full-flow wetted perimeter | $P_f =$                   | <u>4.71</u> ft         |
| Half Central Angle         | $\text{Theta} =$          | <u>3.14</u> rad        |
| <b>Full-flow capacity</b>  | <b><math>Q_f =</math></b> | <b><u>17.0</u> cfs</b> |

### Calculation of Normal Flow Condition

|  |                            |                        |
|--|----------------------------|------------------------|
| Half Central Angle ( $0 < \text{Theta} < 3.14$ ) | $\text{Theta} =$           | <u>2.23</u> rad        |
| Flow area  | $A_n =$                    | <u>1.52</u> sq ft      |
| Top width  | $T_n =$                    | <u>1.19</u> ft         |
| Wetted perimeter                                 | $P_n =$                    | <u>3.34</u> ft         |
| Flow depth                                       | $Y_n =$                    | <u>1.21</u> ft         |
| Flow velocity                                    | $V_n =$                    | <u>10.95</u> fps       |
| <b>Discharge</b>                                 | <b><math>Q_n =</math></b>  | <b><u>16.7</u> cfs</b> |
| <b>Normal Depth Froude Number</b>                | <b><math>Fr_n =</math></b> | <b><u>1.70</u></b>     |

### Calculation of Critical Flow Condition

|  |                            |                    |
|--|----------------------------|--------------------|
| Half Central Angle ( $0 < \text{Theta-c} < 3.14$ ) | $\text{Theta-c} =$         | <u>2.72</u> rad    |
| Critical flow area                                 | $A_c =$                    | <u>1.74</u> sq ft  |
| Critical top width                                 | $T_c =$                    | <u>0.61</u> ft     |
| Critical flow depth                                | $Y_c =$                    | <u>1.44</u> ft     |
| Critical flow velocity                             | $V_c =$                    | <u>9.59</u> fps    |
| <b>Critical Depth Froude Number</b>                | <b><math>Fr_c =</math></b> | <b><u>1.00</u></b> |

## Circular Pipe Flow

Project: **Boondocks**

Pipe ID: **DP 7 to DP 17A**

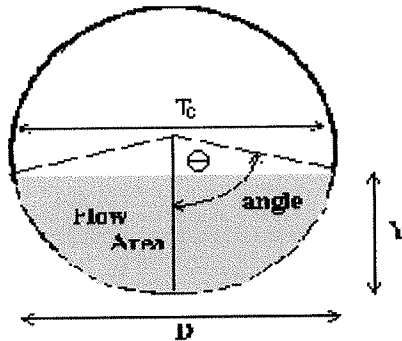

### Design Information (Input)

|                         |                         |                       |
|-------------------------|-------------------------|-----------------------|
| Pipe Invert Slope       | $S_o =$                 | <u>0.0040</u> ft/ft   |
| Pipe Manning's n-value  | $n =$                   | <u>0.0130</u>         |
| Pipe Diameter           | $D =$                   | <u>18.00</u> inches   |
| <b>Design discharge</b> | <b><math>Q =</math></b> | <b><u>1.7</u> cfs</b> |

### Full-flow Capacity (Calculated)

|                            |                           |                       |
|----------------------------|---------------------------|-----------------------|
| Full-flow area             | $A_f =$                   | <u>1.77</u> sq ft     |
| Full-flow wetted perimeter | $P_f =$                   | <u>4.71</u> ft        |
| Half Central Angle         | $\theta =$                | <u>3.14</u> rad       |
| <b>Full-flow capacity</b>  | <b><math>Q_f =</math></b> | <b><u>6.7</u> cfs</b> |

### Calculation of Normal Flow Condition

|  |                            |                       |
|--|----------------------------|-----------------------|
| Half Central Angle ( $0 < \theta < 3.14$ ) | $\theta =$                 | <u>1.26</u> rad       |
| Flow area                                  | $A_n =$                    | <u>0.54</u> sq ft     |
| Top width                                  | $T_n =$                    | <u>1.43</u> ft        |
| Wetted perimeter                           | $P_n =$                    | <u>1.88</u> ft        |
| Flow depth                                 | $Y_n =$                    | <u>0.52</u> ft        |
| Flow velocity                              | $V_n =$                    | <u>3.15</u> fps       |
| <b>Discharge</b>                           | <b><math>Q_n =</math></b>  | <b><u>1.7</u> cfs</b> |
| <b>Normal Depth Froude Number</b>          | <b><math>Fr_n =</math></b> | <b><u>0.90</u></b>    |

### Calculation of Critical Flow Condition

|  |                            |                    |
|--|----------------------------|--------------------|
| Half Central Angle ( $0 < \theta_c < 3.14$ ) | $\theta_c =$               | <u>1.22</u> rad    |
| Critical flow area                           | $A_c =$                    | <u>0.50</u> sq ft  |
| Critical top width                           | $T_c =$                    | <u>1.41</u> ft     |
| Critical flow depth                          | $Y_c =$                    | <u>0.49</u> ft     |
| Critical flow velocity                       | $V_c =$                    | <u>3.39</u> fps    |
| <b>Critical Depth Froude Number</b>          | <b><math>Fr_c =</math></b> | <b><u>1.00</u></b> |

# Circular Pipe Flow

Project: **Boondocks**

Pipe ID: **DP 17A to DP 17B**

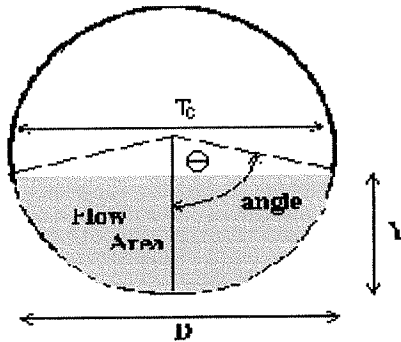

### Design Information (Input)

|                         |                         |                        |
|-------------------------|-------------------------|------------------------|
| Pipe Invert Slope       | $S_o =$                 | <u>0.0260</u> ft/ft    |
| Pipe Manning's n-value  | $n =$                   | <u>0.0130</u>          |
| Pipe Diameter           | $D =$                   | <u>24.00</u> inches    |
| <b>Design discharge</b> | <b><math>Q =</math></b> | <b><u>17.4</u> cfs</b> |

### Full-flow Capacity (Calculated)

|                            |                           |                        |
|----------------------------|---------------------------|------------------------|
| Full-flow area             | $A_f =$                   | <u>3.14</u> sq ft      |
| Full-flow wetted perimeter | $P_f =$                   | <u>6.28</u> ft         |
| Half Central Angle         | $\theta =$                | <u>3.14</u> rad        |
| <b>Full-flow capacity</b>  | <b><math>Q_f =</math></b> | <b><u>36.6</u> cfs</b> |

### Calculation of Normal Flow Condition

|  |                            |                        |
|--|----------------------------|------------------------|
| Half Central Angle ( $0 < \theta < 3.14$ ) | $\theta =$                 | <u>1.54</u> rad        |
| Flow area                                  | $A_n =$                    | <u>1.52</u> sq ft      |
| Top width                                  | $T_n =$                    | <u>2.00</u> ft         |
| Wetted perimeter                           | $P_n =$                    | <u>3.09</u> ft         |
| Flow depth                                 | $Y_n =$                    | <u>0.97</u> ft         |
| Flow velocity                              | $V_n =$                    | <u>11.48</u> fps       |
| <b>Discharge</b>                           | <b><math>Q_n =</math></b>  | <b><u>17.4</u> cfs</b> |
| <b>Normal Depth Froude Number</b>          | <b><math>Fr_n =</math></b> | <b><u>2.32</u></b>     |

### Calculation of Critical Flow Condition

|  |                            |                    |
|--|----------------------------|--------------------|
| Half Central Angle ( $0 < \theta_c < 3.14$ ) | $\theta_c =$               | <u>2.10</u> rad    |
| Critical flow area                           | $A_c =$                    | <u>2.53</u> sq ft  |
| Critical top width                           | $T_c =$                    | <u>1.73</u> ft     |
| Critical flow depth                          | $Y_c =$                    | <u>1.50</u> ft     |
| Critical flow velocity                       | $V_c =$                    | <u>6.87</u> fps    |
| <b>Critical Depth Froude Number</b>          | <b><math>Fr_c =</math></b> | <b><u>1.00</u></b> |

# Circular Pipe Flow

Project: **Boondocks**

Pipe ID: **DP 19 to DP 18**

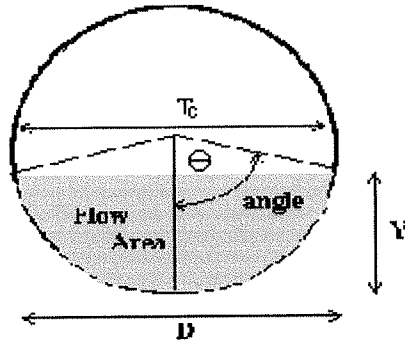

### Design Information (Input)

|                         |                         |                       |
|-------------------------|-------------------------|-----------------------|
| Pipe Invert Slope       | $S_o =$                 | <u>0.0040</u> ft/ft   |
| Pipe Manning's n-value  | $n =$                   | <u>0.0130</u>         |
| Pipe Diameter           | $D =$                   | <u>18.00</u> inches   |
| <b>Design discharge</b> | <b><math>Q =</math></b> | <b><u>3.1</u> cfs</b> |

### Full-flow Capacity (Calculated)

|                            |                           |                       |
|----------------------------|---------------------------|-----------------------|
| Full-flow area             | $A_f =$                   | <u>1.77</u> sq ft     |
| Full-flow wetted perimeter | $P_f =$                   | <u>4.71</u> ft        |
| Half Central Angle         | $\theta =$                | <u>3.14</u> rad       |
| <b>Full-flow capacity</b>  | <b><math>Q_f =</math></b> | <b><u>6.7</u> cfs</b> |

### Calculation of Normal Flow Condition

|  |                            |                       |
|--|----------------------------|-----------------------|
| Half Central Angle ( $0 < \theta < 3.14$ ) | $\theta =$                 | <u>1.53</u> rad       |
| Flow area                                  | $A_n =$                    | <u>0.84</u> sq ft     |
| Top width                                  | $T_n =$                    | <u>1.50</u> ft        |
| Wetted perimeter                           | $P_n =$                    | <u>2.30</u> ft        |
| Flow depth                                 | $Y_n =$                    | <u>0.72</u> ft        |
| Flow velocity                              | $V_n =$                    | <u>3.70</u> fps       |
| <b>Discharge</b>                           | <b><math>Q_n =</math></b>  | <b><u>3.1</u> cfs</b> |
| <b>Normal Depth Froude Number</b>          | <b><math>Fr_n =</math></b> | <b><u>0.87</u></b>    |

### Calculation of Critical Flow Condition

|  |                            |                    |
|--|----------------------------|--------------------|
| Half Central Angle ( $0 < \theta_c < 3.14$ ) | $\theta_c =$               | <u>1.46</u> rad    |
| Critical flow area                           | $A_c =$                    | <u>0.76</u> sq ft  |
| Critical top width                           | $T_c =$                    | <u>1.49</u> ft     |
| Critical flow depth                          | $Y_c =$                    | <u>0.67</u> ft     |
| Critical flow velocity                       | $V_c =$                    | <u>4.06</u> fps    |
| <b>Critical Depth Froude Number</b>          | <b><math>Fr_c =</math></b> | <b><u>1.00</u></b> |

## Circular Pipe Flow

Project: **Boondocks**

Pipe ID: **DP 18 to DP 17B**

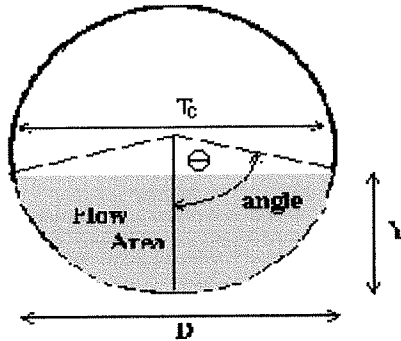

### Design Information (Input)

|                         |                         |                       |
|-------------------------|-------------------------|-----------------------|
| Pipe Invert Slope       | $S_o =$                 | <u>0.0040</u> ft/ft   |
| Pipe Manning's n-value  | $n =$                   | <u>0.0130</u>         |
| Pipe Diameter           | $D =$                   | <u>18.00</u> inches   |
| <b>Design discharge</b> | <b><math>Q =</math></b> | <b><u>5.7</u> cfs</b> |

### Full-flow Capacity (Calculated)

|                            |                           |                       |
|----------------------------|---------------------------|-----------------------|
| Full-flow area             | $A_f =$                   | <u>1.77</u> sq ft     |
| Full-flow wetted perimeter | $P_f =$                   | <u>4.71</u> ft        |
| Half Central Angle         | Theta =                   | <u>3.14</u> rad       |
| <b>Full-flow capacity</b>  | <b><math>Q_f =</math></b> | <b><u>6.7</u> cfs</b> |

### Calculation of Normal Flow Condition

|  |                            |                       |
|--|----------------------------|-----------------------|
| Half Central Angle ( $0 < \theta < 3.14$ ) | Theta =                    | <u>2.01</u> rad       |
| Flow area                                  | $A_n =$                    | <u>1.35</u> sq ft     |
| Top width                                  | $T_n =$                    | <u>1.36</u> ft        |
| Wetted perimeter                           | $P_n =$                    | <u>3.01</u> ft        |
| Flow depth                                 | $Y_n =$                    | <u>1.07</u> ft        |
| Flow velocity                              | $V_n =$                    | <u>4.23</u> fps       |
| <b>Discharge</b>                           | <b><math>Q_n =</math></b>  | <b><u>5.7</u> cfs</b> |
| <b>Normal Depth Froude Number</b>          | <b><math>Fr_n =</math></b> | <b><u>0.75</u></b>    |

### Calculation of Critical Flow Condition

|  |                            |                    |
|--|----------------------------|--------------------|
| Half Central Angle ( $0 < \theta_c < 3.14$ ) | Theta-c =                  | <u>1.80</u> rad    |
| Critical flow area                           | $A_c =$                    | <u>1.14</u> sq ft  |
| Critical top width                           | $T_c =$                    | <u>1.46</u> ft     |
| Critical flow depth                          | $Y_c =$                    | <u>0.92</u> ft     |
| Critical flow velocity                       | $V_c =$                    | <u>5.01</u> fps    |
| <b>Critical Depth Froude Number</b>          | <b><math>Fr_c =</math></b> | <b><u>1.00</u></b> |

## Circular Pipe Flow

Project: **Boondocks**

Pipe ID: **DP 17B to 42** '

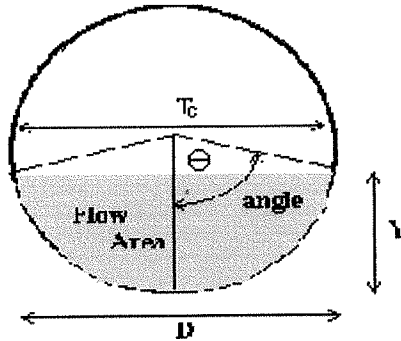

### Design Information (Input)

|                         |                         |                        |
|-------------------------|-------------------------|------------------------|
| Pipe Invert Slope       | $S_o =$                 | <u>0.0050</u> ft/ft    |
| Pipe Manning's n-value  | $n =$                   | <u>0.0130</u>          |
| Pipe Diameter           | $D =$                   | <u>42.00</u> inches    |
| <b>Design discharge</b> | <b><math>Q =</math></b> | <b><u>21.3</u> cfs</b> |

### Full-flow Capacity (Calculated)

|                            |                           |                        |
|----------------------------|---------------------------|------------------------|
| Full-flow area             | $A_f =$                   | <u>9.62</u> sq ft      |
| Full-flow wetted perimeter | $P_f =$                   | <u>11.00</u> ft        |
| Half Central Angle         | Theta =                   | <u>3.14</u> rad        |
| <b>Full-flow capacity</b>  | <b><math>Q_f =</math></b> | <b><u>71.3</u> cfs</b> |

### Calculation of Normal Flow Condition

|  |                            |                        |
|--|----------------------------|------------------------|
| Half Central Angle ( $0 < \theta < 3.14$ ) | Theta =                    | <u>1.32</u> rad        |
| Flow area                                  | $A_n =$                    | <u>3.29</u> sq ft      |
| Top width                                  | $T_n =$                    | <u>3.39</u> ft         |
| Wetted perimeter                           | $P_n =$                    | <u>4.61</u> ft         |
| Flow depth                                 | $Y_n =$                    | <u>1.31</u> ft         |
| Flow velocity                              | $V_n =$                    | <u>6.47</u> fps        |
| <b>Discharge</b>                           | <b><math>Q_n =</math></b>  | <b><u>21.3</u> cfs</b> |
| <b>Normal Depth Froude Number</b>          | <b><math>Fr_n =</math></b> | <b><u>1.16</u></b>     |

### Calculation of Critical Flow Condition

|  |                            |                    |
|--|----------------------------|--------------------|
| Half Central Angle ( $0 < \theta_c < 3.14$ ) | Theta-c =                  | <u>1.38</u> rad    |
| Critical flow area                           | $A_c =$                    | <u>3.65</u> sq ft  |
| Critical top width                           | $T_c =$                    | <u>3.44</u> ft     |
| Critical flow depth                          | $Y_c =$                    | <u>1.42</u> ft     |
| Critical flow velocity                       | $V_c =$                    | <u>5.84</u> fps    |
| <b>Critical Depth Froude Number</b>          | <b><math>Fr_c =</math></b> | <b><u>1.00</u></b> |

# Circular Pipe Flow

Project: **Boondocks**

Pipe ID: **DP 17B to 30"**

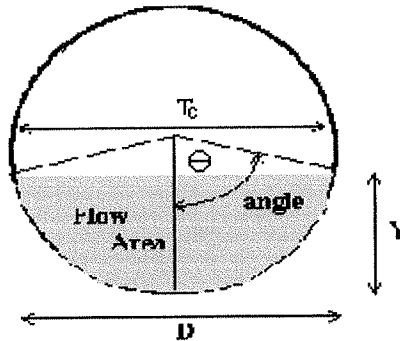

### Design Information (Input)

|                         |                         |                        |
|-------------------------|-------------------------|------------------------|
| Pipe Invert Slope       | $S_o =$                 | <u>0.0050</u> ft/ft    |
| Pipe Manning's n-value  | $n =$                   | <u>0.0130</u>          |
| Pipe Diameter           | $D =$                   | <u>30.00</u> inches    |
| <b>Design discharge</b> | <b><math>Q =</math></b> | <b><u>21.3</u> cfs</b> |

### Full-flow Capacity (Calculated)

|                            |                           |                        |
|----------------------------|---------------------------|------------------------|
| Full-flow area             | $A_f =$                   | <u>4.91</u> sq ft      |
| Full-flow wetted perimeter | $P_f =$                   | <u>7.85</u> ft         |
| Half Central Angle         | $\theta =$                | <u>3.14</u> rad        |
| <b>Full-flow capacity</b>  | <b><math>Q_f =</math></b> | <b><u>29.1</u> cfs</b> |

### Calculation of Normal Flow Condition

|  |                            |                        |
|--|----------------------------|------------------------|
| Half Central Angle ( $0 < \theta < 3.14$ ) | $\theta =$                 | <u>1.85</u> rad        |
| Flow area                                  | $A_n =$                    | <u>3.29</u> sq ft      |
| Top width                                  | $T_n =$                    | <u>2.41</u> ft         |
| Wetted perimeter                           | $P_n =$                    | <u>4.62</u> ft         |
| Flow depth                                 | $Y_n =$                    | <u>1.59</u> ft         |
| Flow velocity                              | $V_n =$                    | <u>6.47</u> fps        |
| <b>Discharge</b>                           | <b><math>Q_n =</math></b>  | <b><u>21.3</u> cfs</b> |
| <b>Normal Depth Froude Number</b>          | <b><math>Fr_n =</math></b> | <b><u>0.97</u></b>     |

### Calculation of Critical Flow Condition

|  |                            |                    |
|--|----------------------------|--------------------|
| Half Central Angle ( $0 < \theta_c < 3.14$ ) | $\theta_c =$               | <u>1.83</u> rad    |
| Critical flow area                           | $A_c =$                    | <u>3.24</u> sq ft  |
| Critical top width                           | $T_c =$                    | <u>2.42</u> ft     |
| Critical flow depth                          | $Y_c =$                    | <u>1.57</u> ft     |
| Critical flow velocity                       | $V_c =$                    | <u>6.57</u> fps    |
| <b>Critical Depth Froude Number</b>          | <b><math>Fr_c =</math></b> | <b><u>1.00</u></b> |

D.19

Scenario: Base

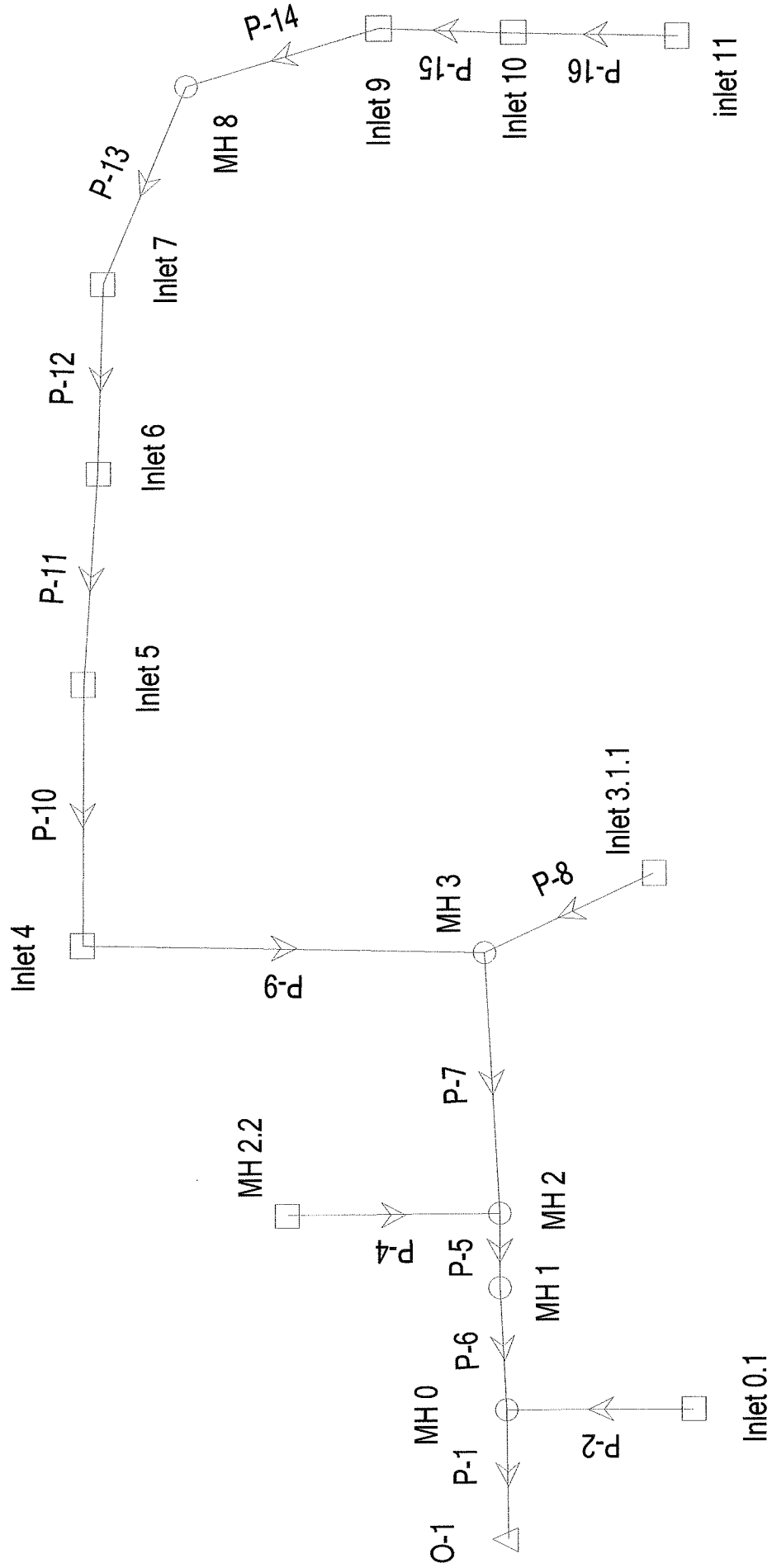

Scenario: Base

Combined Pipe\Node Report

| Upstream Node | Downstream Node | Label | Length (ft) | Section Size | Upstream Invert Elevation (ft) | Downstream Invert Elevation (ft) | Design Capacity (cfs) | Total Flow (cfs) | Average Velocity (ft/s) | Constructed Slope (ft/ft) | Hydraulic Grade Line In (ft) | Hydraulic Slope (ft/ft) | Hydraulic Grade Line Out (ft) | Energy Slope (ft/ft) | Energy Grade Line In (ft) | Energy Grade Line Out (ft) |
|---------------|-----------------|-------|-------------|--------------|--------------------------------|----------------------------------|-----------------------|------------------|-------------------------|---------------------------|------------------------------|-------------------------|-------------------------------|----------------------|---------------------------|----------------------------|
| Inlet 11      | Inlet 10        | P-16  | 84.00       | 18 inch      | 5,802.89                       | 5,802.19                         | 8.10                  | 1.30             | 3.36                    | 0.005952                  | 5,803.12                     | 0.002923                | 5,802.87                      | 0.004232             | 5,803.27                  | 5,802.91                   |
| Inlet 10      | Inlet 9         | P-15  | 134.00      | 18 inch      | 5,802.19                       | 5,800.93                         | 10.19                 | 3.20             | 5.10                    | 0.009403                  | 5,802.87                     | 0.009240                | 5,801.63                      | 0.009393             | 5,803.13                  | 5,801.87                   |
| Inlet 9       | MH 8            | P-14  | 125.00      | 18 inch      | 5,800.93                       | 5,799.88                         | 9.63                  | 3.40             | 4.98                    | 0.008400                  | 5,801.63                     | 0.009100                | 5,800.50                      | 0.008193             | 5,801.90                  | 5,800.88                   |
| MH 8          | Inlet 7         | P-13  | 133.00      | 18 inch      | 5,799.88                       | 5,798.79                         | 9.51                  | 3.40             | 4.93                    | 0.008195                  | 5,800.58                     | 0.006947                | 5,799.66                      | 0.007790             | 5,800.85                  | 5,799.82                   |
| Inlet 7       | Inlet 6         | P-12  | 97.50       | 18 inch      | 5,798.79                       | 5,795.37                         | 19.67                 | 5.10             | 9.35                    | 0.035077                  | 5,799.66                     | 0.033960                | 5,796.35                      | 0.034855             | 5,800.02                  | 5,796.62                   |
| Inlet 6       | Inlet 5         | P-11  | 150.00      | 18 inch      | 5,795.37                       | 5,793.11                         | 12.89                 | 6.40             | 7.28                    | 0.015067                  | 5,796.35                     | 0.014562                | 5,794.16                      | 0.015000             | 5,796.78                  | 5,794.53                   |
| Inlet 5       | Inlet 4         | P-10  | 137.00      | 18 inch      | 5,793.11                       | 5,789.61                         | 16.79                 | 7.40             | 9.20                    | 0.025547                  | 5,794.16                     | 0.025092                | 5,790.73                      | 0.025499             | 5,794.65                  | 5,791.15                   |
| Inlet 4       | MH 3            | P-9   | 79.00       | 18 inch      | 5,789.61                       | 5,787.36                         | 17.73                 | 8.30             | 9.87                    | 0.028481                  | 5,790.73                     | 0.033411                | 5,788.09                      | 0.021412             | 5,791.26                  | 5,789.57                   |
| Inlet 3.1.1   | MH 3            | P-8   | 65.00       | 18 inch      | 5,790.36                       | 5,787.36                         | 22.57                 | 0.30             | 4.47                    | 0.046154                  | 5,790.56                     | 0.033172                | 5,788.41                      | 0.034227             | 5,790.63                  | 5,788.41                   |
| MH 3          | MH 2            | P-7   | 155.00      | 24 inch      | 5,787.36                       | 5,783.11                         | 37.46                 | 8.60             | 9.68                    | 0.027419                  | 5,788.41                     | 0.026566                | 5,784.29                      | 0.027249             | 5,788.82                  | 5,784.60                   |
| MH 1          | MH 0            | P-6   | 30.00       | 42 inch      | 5,780.18                       | 5,780.00                         | 77.93                 | 10.80            | 5.69                    | 0.006000                  | 5,781.18                     | 0.005528                | 5,781.01                      | 0.005987             | 5,781.53                  | 5,781.35                   |
| MH 2          | MH 1            | P-5   | 22.00       | 24 inch      | 5,783.11                       | 5,780.18                         | 82.55                 | 10.80            | 18.17                   | 0.133182                  | 5,784.29                     | 0.160297                | 5,780.76                      | 0.039397             | 5,784.78                  | 5,783.91                   |
| MH 2.2        | MH 2            | P-4   | 50.00       | 12 inch      | 5,787.00                       | 5,783.11                         | 12.92                 | 2.20             | 12.27                   | 0.077800                  | 5,787.63                     | 0.066923                | 5,784.29                      | 0.069939             | 5,787.91                  | 5,784.41                   |
| Inlet 0.1     | MH 0            | P-2   | 100.00      | 12 inch      | 5,782.50                       | 5,780.00                         | 7.32                  | 0.30             | 4.58                    | 0.025000                  | 5,782.73                     | 0.017159                | 5,781.01                      | 0.017932             | 5,782.80                  | 5,781.01                   |
| MH 0          | O-1             | P-1   | 100.00      | 42 inch      | 5,780.00                       | 5,779.48                         | 72.55                 | 11.10            | 5.45                    | 0.005200                  | 5,781.01                     | 0.006041                | 5,780.41                      | 0.005043             | 5,781.37                  | 5,780.87                   |

5 year

D21

Scenario: Base

Combined Pipe/Node Report

| Upstream Node | Downstream Node | Label | Length (ft) | Section Size | Upstream Invert Elevation (ft) | Downstream Invert Elevation (ft) | Design Capacity (cfs) | Total Flow (cfs) | Average Velocity (ft/s) | Constructed Slope (ft/ft) | Hydraulic Grade Line In (ft) | Hydraulic Slope (ft/ft) | Hydraulic Grade Line Out (ft) | Energy Slope (ft/ft) | Energy Grade Line In (ft) | Energy Grade Line Out (ft) |
|---------------|-----------------|-------|-------------|--------------|--------------------------------|----------------------------------|-----------------------|------------------|-------------------------|---------------------------|------------------------------|-------------------------|-------------------------------|----------------------|---------------------------|----------------------------|
| Inlet 11      | Inlet 10        | P-16  | 84.00       | 18 inch      | 5,802.69                       | 5,802.19                         | 8.10                  | 3.00             | 4.24                    | 0.005952                  | 5,803.35                     | 0.001423                | 5,803.23                      | 0.003431             | 5,803.60                  | 5,803.31                   |
| Inlet 10      | Inlet 9         | P-15  | 134.00      | 18 inch      | 5,802.19                       | 5,800.93                         | 10.19                 | 7.20             | 6.25                    | 0.009403                  | 5,803.23                     | 0.009188                | 5,802.00                      | 0.009392             | 5,803.70                  | 5,802.44                   |
| Inlet 9       | MH 8            | P-14  | 125.00      | 18 inch      | 5,800.93                       | 5,799.88                         | 9.63                  | 7.60             | 6.04                    | 0.008400                  | 5,802.00                     | 0.008904                | 5,800.89                      | 0.008335             | 5,802.49                  | 5,801.45                   |
| MH 8          | Inlet 7         | P-13  | 133.00      | 18 inch      | 5,799.88                       | 5,798.79                         | 9.51                  | 7.60             | 5.98                    | 0.008195                  | 5,800.95                     | 0.006537                | 5,800.08                      | 0.007676             | 5,801.44                  | 5,800.42                   |
| Inlet 7       | Inlet 6         | P-12  | 97.50       | 18 inch      | 5,798.79                       | 5,795.37                         | 19.67                 | 11.40            | 11.54                   | 0.035077                  | 5,800.08                     | 0.034182                | 5,796.75                      | 0.034932             | 5,800.85                  | 5,797.45                   |
| Inlet 6       | Inlet 5         | P-11  | 150.00      | 18 inch      | 5,795.37                       | 5,793.11                         | 12.89                 | 13.80            | 8.17                    | 0.015067                  | 5,796.75                     | 0.014789                | 5,794.53                      | 0.015037             | 5,797.77                  | 5,795.52                   |
| Inlet 5       | Inlet 4         | P-10  | 137.00      | 18 inch      | 5,793.11                       | 5,789.61                         | 16.79                 | 15.60            | 10.79                   | 0.025547                  | 5,794.53                     | 0.025416                | 5,791.05                      | 0.025539             | 5,796.79                  | 5,792.29                   |
| Inlet 4       | MH 3            | P-9   | 79.00       | 18 inch      | 5,789.61                       | 5,787.36                         | 17.73                 | 16.70            | 11.41                   | 0.028481                  | 5,791.05                     | 0.027620                | 5,788.86                      | 0.028156             | 5,792.48                  | 5,790.25                   |
| Inlet 3.1.1   | MH 3            | P-8   | 65.00       | 18 inch      | 5,790.36                       | 5,787.36                         | 22.57                 | 0.70             | 5.77                    | 0.046154                  | 5,790.67                     | 0.027801                | 5,788.86                      | 0.029438             | 5,790.78                  | 5,788.87                   |
| MH 3          | MH 2            | P-7   | 155.00      | 24 inch      | 5,787.36                       | 5,783.11                         | 37.46                 | 17.40            | 11.70                   | 0.027419                  | 5,788.86                     | 0.026461                | 5,784.76                      | 0.027250             | 5,789.60                  | 5,785.37                   |
| MH 1          | MH 0            | P-6   | 30.00       | 42 inch      | 5,780.18                       | 5,780.00                         | 77.93                 | 21.30            | 6.90                    | 0.006000                  | 5,781.60                     | 0.005655                | 5,781.43                      | 0.005995             | 5,782.13                  | 5,781.95                   |
| MH 2          | MH 1            | P-5   | 22.00       | 24 inch      | 5,783.11                       | 5,780.18                         | 82.55                 | 21.30            | 22.04                   | 0.133182                  | 5,784.76                     | 0.167899                | 5,781.07                      | 0.033123             | 5,785.68                  | 5,784.95                   |
| MH 2.2        | MH 2            | P-4   | 50.00       | 12 inch      | 5,787.00                       | 5,783.11                         | 12.92                 | 3.90             | 14.40                   | 0.077800                  | 5,787.84                     | 0.061530                | 5,784.76                      | 0.063424             | 5,788.32                  | 5,785.15                   |
| Inlet 0.1     | MH 0            | P-2   | 100.00      | 12 inch      | 5,782.50                       | 5,780.00                         | 7.32                  | 0.30             | 4.58                    | 0.025000                  | 5,782.73                     | 0.013000                | 5,781.43                      | 0.013773             | 5,782.80                  | 5,781.43                   |
| MH 0          | O-1             | P-1   | 100.00      | 42 inch      | 5,780.00                       | 5,779.48                         | 72.55                 | 21.60            | 6.58                    | 0.005200                  | 5,781.43                     | 0.006363                | 5,780.79                      | 0.004991             | 5,781.96                  | 5,781.46                   |

100 year

D.22

Scenario: Base

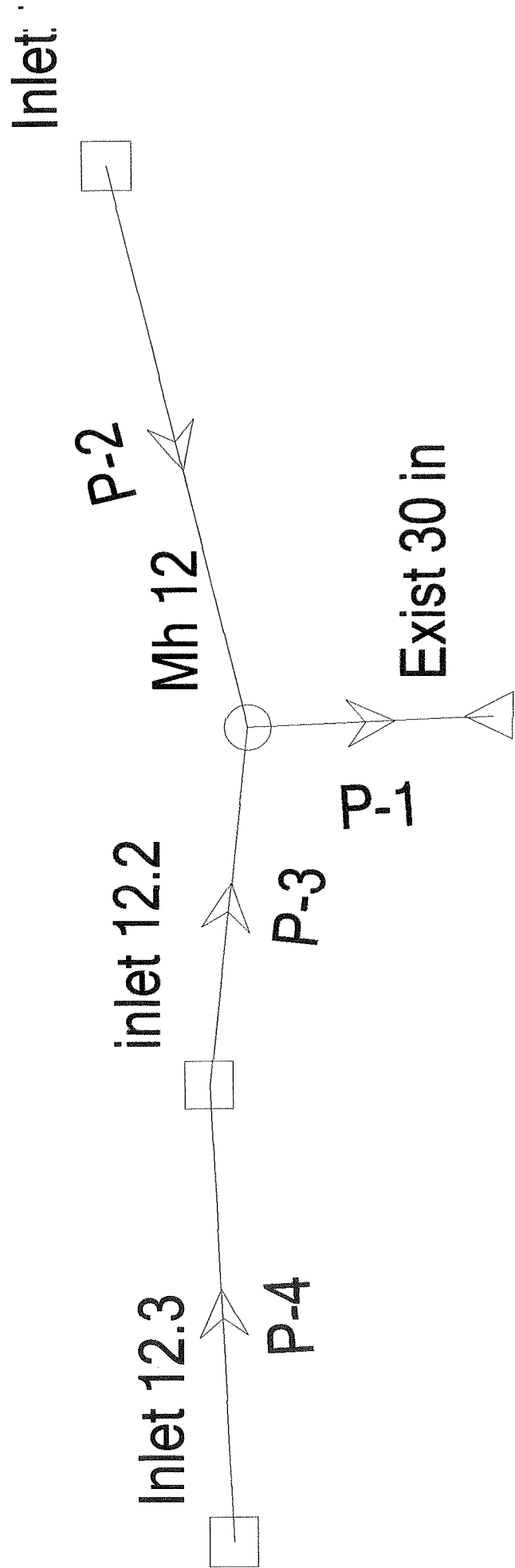

0.23

Scenario: Base

Combined Pipe/Node Report

| Upstream Node | Downstream Node | Label | Length (ft) | Section Size | Upstream Invert Elevation (ft) | Downstream Invert Elevation (ft) | Design Capacity (cfs) | Total Flow (cfs) | Average Velocity (ft/s) | Constructed Slope (ft/ft) | Hydraulic Grade Line In (ft) | Hydraulic Slope (ft/ft) | Hydraulic Grade Line Out (ft) | Energy Slope (ft/ft) | Energy Grade Line In (ft) | Energy Grade Line Out (ft) |
|---------------|-----------------|-------|-------------|--------------|--------------------------------|----------------------------------|-----------------------|------------------|-------------------------|---------------------------|------------------------------|-------------------------|-------------------------------|----------------------|---------------------------|----------------------------|
| Inlet 12.3    | inlet 12.2      | P-4   | 74.00       | 18 inch      | 5,795.60                       | 5,791.60                         | 24.42                 | 5.40             | 11.10                   | 0.054054                  | 5,796.50                     | 0.051818                | 5,792.66                      | 0.053445             | 5,796.87                  | 5,792.91                   |
| inlet 12.2    | Mh 12           | P-3   | 48.00       | 18 inch      | 5,791.60                       | 5,790.00                         | 19.18                 | 7.50             | 10.19                   | 0.033333                  | 5,792.66                     | 0.032971                | 5,791.08                      | 0.033322             | 5,793.15                  | 5,791.55                   |
| inlet 12.1    | Mh 12           | P-2   | 23.00       | 18 inch      | 5,790.46                       | 5,790.00                         | 14.85                 | 2.90             | 6.52                    | 0.020000                  | 5,791.11                     | 0.001236                | 5,791.08                      | 0.008847             | 5,791.35                  | 5,791.15                   |
| Mh 12         | Exist 30 in     | P-1   | 25.00       | 30 inch      | 5,790.00                       | 5,788.00                         | 116.01                | 10.40            | 14.64                   | 0.080000                  | 5,791.08                     | 0.043136                | 5,790.00                      | 0.055711             | 5,791.49                  | 5,790.09                   |

100 year

0.24

**APPENDIX E**

**References**

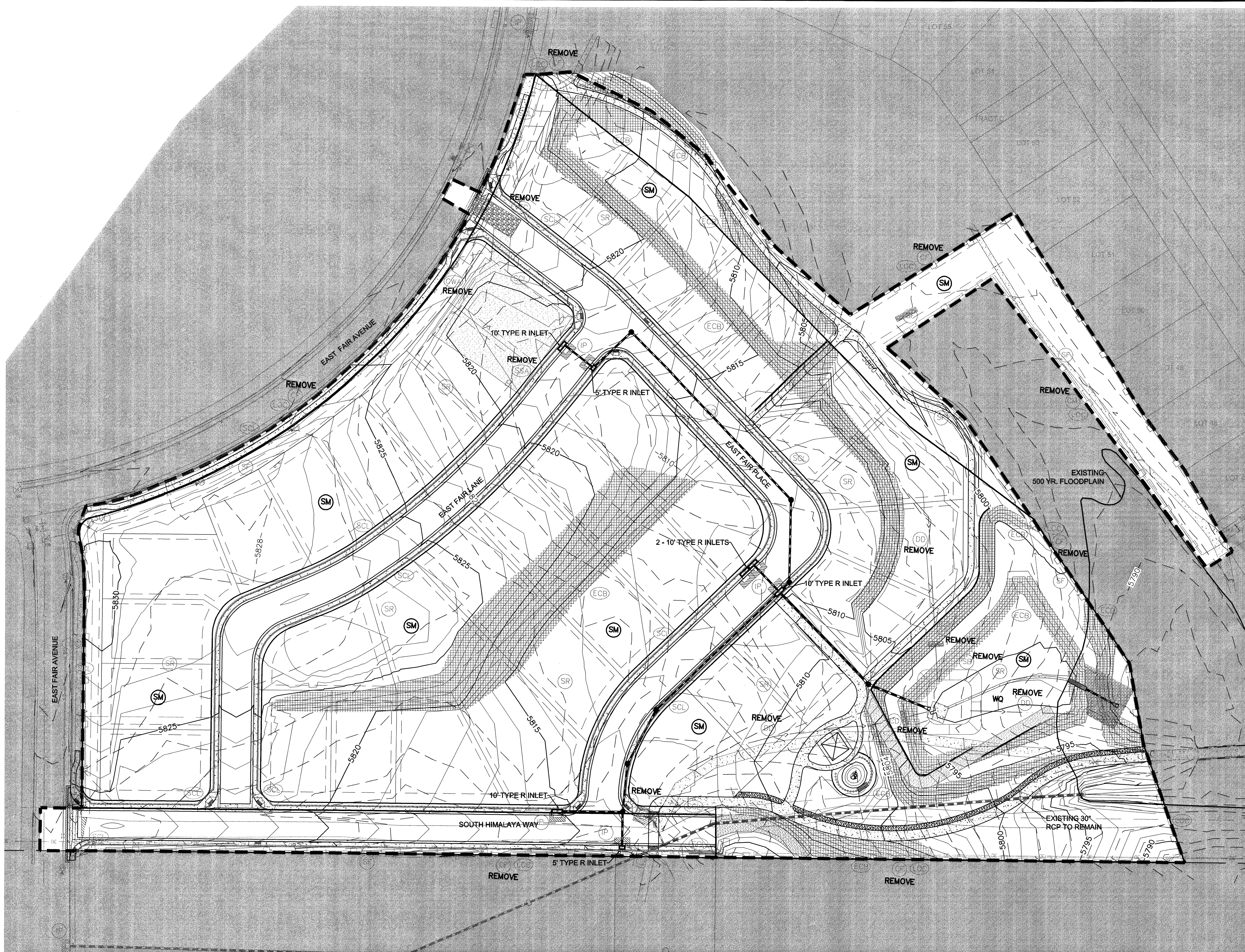

**BMP LEGEND**

|  |            |                            |
|--|------------|----------------------------|
|  | <b>CD</b>  | CHECK DAM                  |
|  | <b>CB</b>  | COMPOST BLANKET            |
|  | <b>CFB</b> | COMPOST FILTER BERM        |
|  | <b>CWA</b> | CONCRETE WASHOUT AREA      |
|  | <b>CF</b>  | CONSTRUCTION FENCE         |
|  | <b>CM</b>  | CONSTRUCTION MARKER        |
|  | <b>DW</b>  | DEWATERING                 |
|  | <b>DD</b>  | DIVERSION DITCH            |
|  | <b>ECB</b> | EROSION CONTROL BLANKET    |
|  | <b>IP</b>  | INLET PROTECTION           |
|  | <b>RCD</b> | REINFORCED CHECK DAM       |
|  | <b>RRB</b> | REINFORCED ROCK BERM       |
|  | <b>RRC</b> | RRB FOR CULVERT PROTECTION |
|  | <b>SB</b>  | SEDIMENT BASIN             |
|  | <b>SCL</b> | SEDIMENT CONTROL LOG       |
|  | <b>ST</b>  | SEDIMENT TRAP              |
|  | <b>SM</b>  | SEEDING AND MULCHING       |
|  | <b>SF</b>  | SILT FENCE                 |
|  | <b>SSA</b> | STABILIZED STAGING AREA    |
|  | <b>SR</b>  | SURFACE ROUGHENING         |
|  | <b>TSD</b> | TEMPORARY SLOPE DRAIN      |
|  | <b>TSC</b> | TEMPORARY STREAM CROSSING  |
|  | <b>TER</b> | TERRACING                  |
|  | <b>VTC</b> | VEHICLE TRACKING CONTROL   |
|  | <b>WW</b>  | VTC WITH WHEEL WASH        |
|  |            | ROCK AND RIPRAP GRADATIONS |
|  | <b>LOC</b> | LIMITS OF CONSTRUCTION     |

--- EXISTING 2' CONTOUR  
 - - - EXISTING 10' CONTOUR  
 - - - PROPOSED 1' CONTOUR  
 - - - PROPOSED 5' CONTOUR

- NOTES:**
- SEE COVER SHEET OF THE SEMSWA STANDARD NOTES AND DETAILS (SHEET 1 OF 4) FOR LEGEND OF BMP NAMES AND SYMBOLS.
  - SHADED BMPs WERE INSTALLED IN INITIAL OR INTERIM GESC DRAWING AND, UNLESS OTHERWISE INDICATED, SHALL BE LEFT IN PLACE UNTIL REVEGETATION ESTABLISHMENT IS APPROVED BY SEMSWA.
  - BENCHMARK: 2" BRASS CAP MARKED ART IN THE SOUTHWEST CORNER OF A CONCRETE TRANSFORMER PAD LOCATED 600 FEET NORTH OF ARAPAHOE ROAD, AND 100 FEET EAST OF LIVERPOOL. ELEVATION 5820.19 USGS NAVD83.
  - SEE CONSTRUCTION PLANS FOR DETAILS OF PERMANENT DRAINAGE FACILITIES SUCH AS DETENTION FACILITIES, CULVERTS, STORM DRAINAGE AND OUTLET PROTECTION.
  - SEDIMENT CONTROL LOGS (SCL) SHALL BE INSTALLED IMMEDIATELY FOLLOWING PLACEMENT OF THE CURB AND/OR SIDEWALK AND SHALL BE MAINTAINED IN GOOD WORKING ORDER UNTIL FINAL VEGETATION IS ESTABLISHED.
  - THE SEDIMENT BASIN SHALL REMAIN IN PLACE UNTIL THE UPSTREAM TRIBUTARY AREA IS STABILIZED (PAVEMENT/BACK OF CURB BMPs/STABILIZATION OF OPEN LOTS). AT THIS TIME THE SEDIMENT BASIN SHALL BE CONVERTED TO THE PERMANENT WATER QUALITY FEATURE.

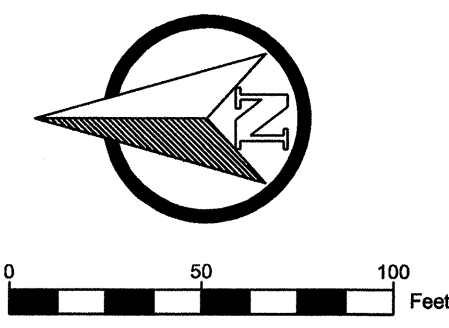

SEMSWA CASE NO. D13-1038

**Southeast Metro Stormwater Authority**  
 DIRECTOR, ENGINEERING & CONSTRUCTION DIVISION  
 Approved for Grading and Stormwater Improvements, or Grading, Erosion & Sediment Control

DATE \_\_\_\_\_  
 THESE PLANS HAVE BEEN REVIEWED BY SEMSWA FOR GRADING, EROSION, AND SEDIMENT CONTROL IMPROVEMENTS ONLY.  
 SEMSWA ACCEPTANCE BLOCK

FINAL GESC PLAN  
 GREENFIELD FILING NO. 9  
 VILLAGE HOMES, INC.  
 CITY OF CENTENNIAL, COLORADO

Project Number: 13008  
 Drawn By: RCE  
 Checked By: RCE  
 08-12-14