

Boondocks
Lot 4A, Crown Point Filing #1
 LOCATED IN A PORTION OF THE SW 1/4 OF SECTION 3,
 T6S, R66W, 6TH P.M., COUNTY OF DOUGLAS, STATE OF COLORADO.

CONSTRUCTION PLAN SET

LEGAL DESCRIPTION:

Lot 4, Crown Point F#1, 14th Amendment--Reception # 2007081477 of the records of Arapahoe County, Colorado. Containing 847,936 square feet, 14.875 acres, More or Less.

PROPOSED LEGAL DESCRIPTION:

The following descriptions are a part of lot 4; Crown Point F # 1, 14th Amendment Rec # 2007081477, Arapahoe County, Colorado and describes two parcels (A&B) which are to be included in a replat of the said lot 4;

Parcel A

Beginning at the northeast corner of said lot 4;
 Thence southerly along the east line of lot 4, which is coincident with west ROW line of E 470, S11°07'44"W, 191.10 feet;
 Thence leaving said coincident east line with west ROW line of E470; N70°01'13"W; 586.59 feet;
 Thence S00°00'00"E, 384.86 feet to a platted corner on said lot 4; said platted corner being the northeast corner of lot 2, Crown Point F #1, 14th Amendment, Reception # 20070081477; Arapahoe County, Colorado;
 Thence along a common lot line of lot 24, lot 4, said Crown Point F#1, 14th amendment; N90°00'00"W, 238.60 ft to a common corner of lot 3, Crown Point F#1, 14th amendment, reception #2007081477, and lot 4;
 Thence along a common property line of said lots 3 and 4 N00°06'31"W, 634.97 feet to a point on the south ROW line of Cottonwood Dr, Rec. # 00073633, Arapahoe County, Colorado;
 Thence along said south ROW line on a curve to the right having a chord of S74°15'58"E 526.95 ft and a radius of 2,702.00 ft with a central angle of 111°13'0" with an arc length of 527.79 ft to a point of Tangent;
 Thence continuing along said south ROW line S68°40'13"E, 90.33 feet.;
 Thence continuing along the said south ROW line S70°34'46"E, 240.13 ft. to the POINT OF BEGINNING.

Area of Parcel A 5.969 acres.

Parcel B

Beginning at the northeast corner of said lot 4;
 Thence along the east line of lot 4 which is coincident of the west ROW of E 470; S4°07'44"W, 191.10 feet to the TRUE POINT OF BEGINNING;
 Thence along the common lot line of lot 4 and west ROW of E 470 along the following 5 courses and distances;

- 1) Thence S11°07'44"W, 118.21 feet
 - 2) Thence S14°52'44"W, 95.13 feet to a point of curve;
 - 3) Thence on a curve to the right having a radius of 1,075.92'; a central angle of 22°03'52", an arc length of 414.33 ft and a chord of S25°54'40"W, 411.78 ft to a point of tangent.
 - 4) Thence S36°56'36"W, 228.17ft to a point of curve to the right;
 - 4) Thence on a curve to the right having a radius of 549.41 ft, a central angle of 25°49'10", an arc length of 247.58 ft and a chord of S49°51'11"W; 245.49 ft to the furthest south property corner of said lot 4;
- Thence leaving said E 470 ROW line and continuing north along the common lot line of lot 3, Crown Point F#1, 14th Amendment N00°00'00"E, 732.63 ft to the northeast corner of said lot 3, thence continuing N00°00'00"E, 384.46 ft;
 Thence S70°13'01"E, 586.59 ft to the TRUE POINT OF BEGINNING of Parcel B

Parcel B contains 8.906 acres.

TOWN OF PARKER CONTACTS:

Tom Williams, P.E. -- Engineering & Stormwater Manager: (303) 840-9546
 Michael Waugh -- Engineering Inspections Supervisor: (303) 805-3231 (Direct) (303) 434-9260 (Cell)
 Alex Mestdagh, P.E. -- Sr. Development Review Engineer: (303) 805-3204 (Direct) (303) 434-9306 (Cell)
 Jacob James, P.E. -- Stormwater Project Engineer (303) 805-3166 (Direct) (303) 242-4920 (Cell)
 Adam Nelson -- Environmental Program Manager: (303) 805-3226 (Direct) (303) 434-6590 (Cell)
 Alvin Lamle -- Stormwater Technician: (303) 805-3239 (Direct) (303) 434-3778 (Cell)
 Kurt Patrick ?Engineering Technician: (303) 805-3209 (Direct) (303) 961-1057 (Cell)

UTILITY CONTACTS:

Intermountain REA Mr. Jim Potter 5496 North US Highway 85 Sedalia, CO 80135 (303) 688-3100	Xcel Energy 1123 West 3rd Avenue Denver, CO 80223 Builder's Call Line (800) 628-2121
Comcast Cable Mr. Butch Buster 6850 South Tucson Way Englewood, CO 80112 (303) 603-5628	Cottonwood Water & Sanitation District Mr. Patrick F. Mulhern/Laurie Tatlock 2 Inverness Drive East, Suite 200 Englewood, CO 80112 (303) 649-9509
CenturyLink Mr. William Benson 9750 East Costilla Avenue Englewood, CO 80112 (720) 578-5142	

BENCHMARK:

A BRASS DISK SET IN CONCRETE FLUSH WITH THE GROUND AND MARKED WITH A DOUGLAS COUNTY FIBERGLASS WITNESS POST, 125 FEET NORTH OF THE CENTERLINE OF A DRIVEWAY, 84 FEET SOUTH OF A DOUBLE 36 IN. CULVERT, 25 FEET WEST OF THE EDGE OF PARKER ROAD, AND 25 FEET EAST OF THE WEST RIGHT OF WAY FENCE.
 ELEVATION = 5734.24

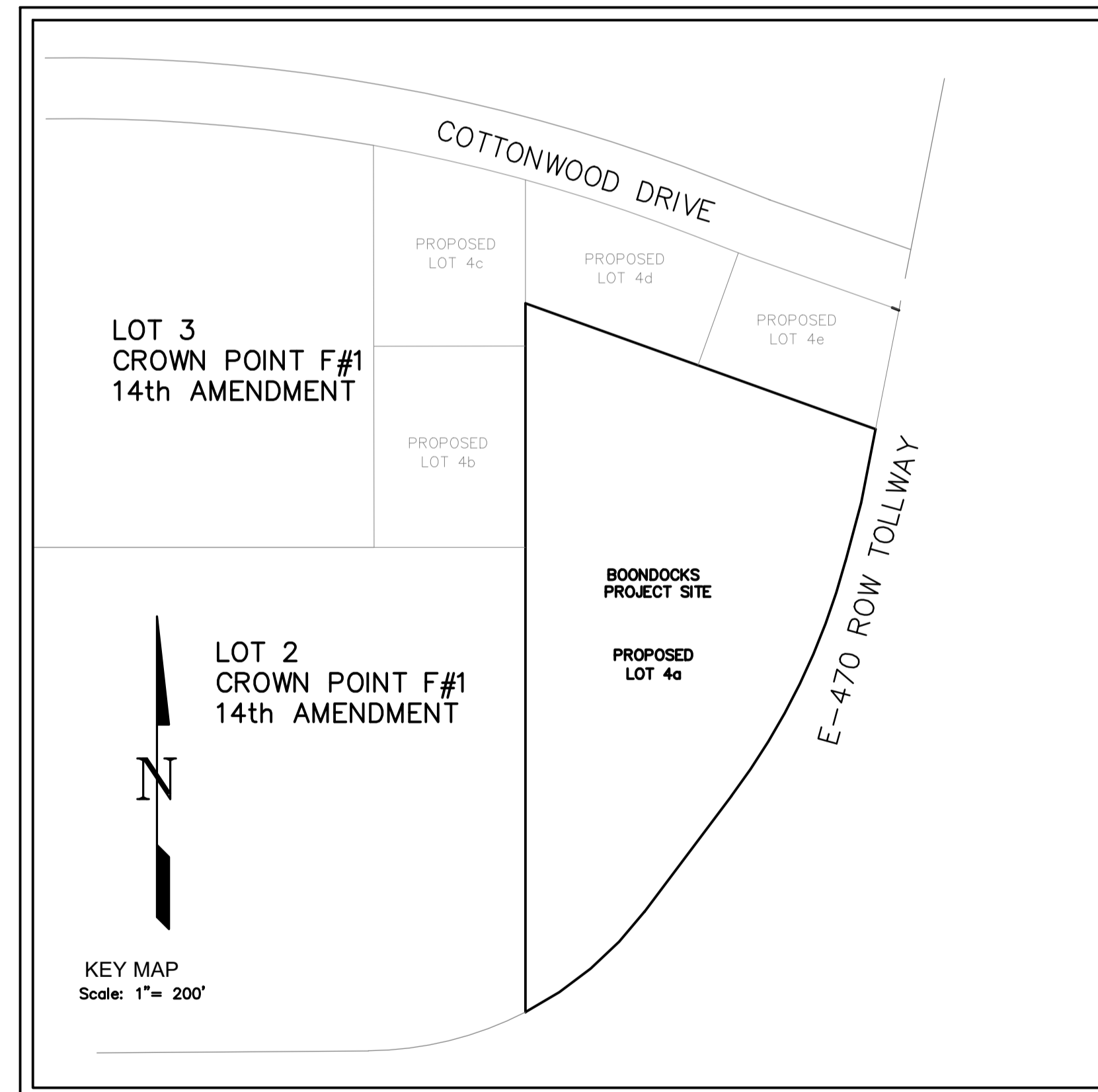
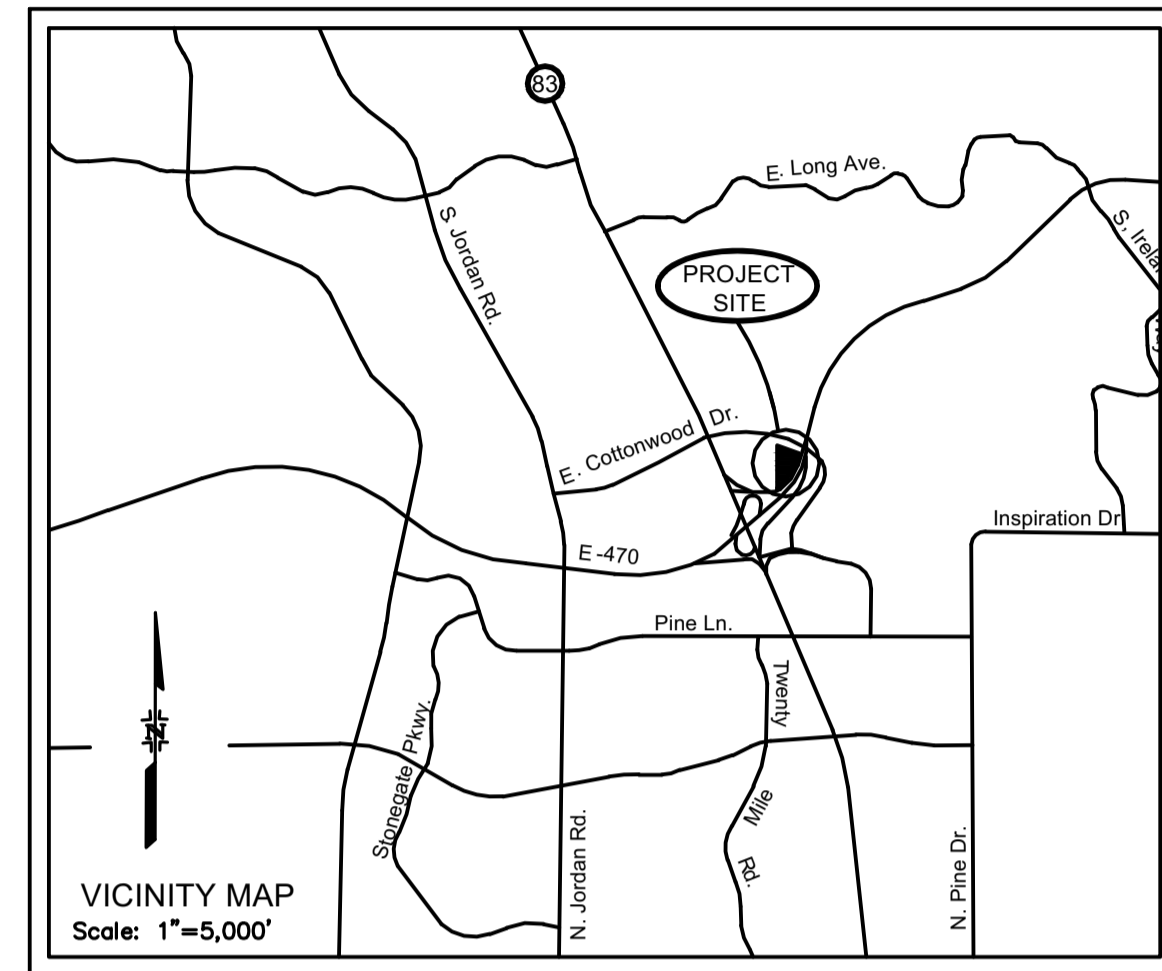

LEGEND

	EXISTING ELEVATION
	PROPOSED ELEVATION
	EXISTING MAJOR CONTOUR
	EXISTING MINOR CONTOUR
	PROPOSED MAJOR CONTOUR
	PROPOSED MINOR CONTOUR
	PROPOSED 6" VERTICAL CURB & GUTTER AND PARKING LOT STRIPING
	PROPOSED LIGHTING FIXTURE
	PROPOSED FENCE
	PROPOSED STORM SEWER W/ MANHOLE & INLET
	EXISTING STORM SEWER W/ MANHOLE
	EXISTING FIRE HYDRANT
	PROPOSED FIRE HYDRANT
	EXISTING WATER LINE W/VALVE & TEE
	PROPOSED WATER LINE W/VALVE & TEE
	EXISTING SANITARY SEWER W/MANHOLE
	PROPOSED SANITARY SEWER W/MANHOLE
	PROPOSED SIGN
	EXISTING EASEMENT
	PROPOSED EASEMENT
	PROPOSED CONCRETE PAN

SHEET INDEX:

CIVIL ENGINEERING PLANS	
SHEET 1	COVER SHEET
SHEET 2	NOTES
SHEET 3	SITE PLAN W/SIGNAGE & HORIZONTAL CONTROL
SHEET 4	HORIZONTAL CONTROL TABLE
SHEETS 5-6	GRADING PLAN
SHEET 7	EROSION CONTROL PLAN ~ INITIAL STAGE
SHEET 8	EROSION CONTROL PLAN ~ INTERIM STAGE
SHEET 9	EROSION CONTROL PLAN ~ FINAL STAGE
SHEETS 10-15	EROSION CONTROL PLAN NOTES & DETAILS
SHEETS 16-18	STORM SEWER PLAN & PROFILE
SHEET 19	ACCESS PLAN & PROFILE
SHEET 20	CROSS SECTIONS AT E-470 PLAN
SHEET 21	CROSS SECTIONS AT E-470 PROFILE
SHEET 22	'V' CHANNEL OFF SITE
SHEETS 23-24	DETAIL SHEETS

LAND USE SUMMARY TABLE:

TOTAL BUILDING AREA:	62,678.0 SF	15.9% OF TOTAL SITE
TOTAL PARKING AREA:	126,496.0 SF	32.1% OF TOTAL SITE
PARKING LOT LANDSCAPING:	12,674.0 SF	10.0% OF TOTAL PARKING AREA
DRIVE AISLES:	83,111.0 SF	6.6% OF TOTAL PARKING AREA
SITE LANDSCAPED AREA:	105,038.0 SF	26.7% OF TOTAL SITE
OUTDOOR RECREATIONAL AREA:	99,482.0 SF	25.3% OF TOTAL SITE
TOTAL SITE	393,695.6 SF	100% OF TOTAL SITE

The Town of Parker review constitutes general compliance with the Town's Standards and approved variances, subject to these plans being stamped, signed, and dated by the professional engineer of record. Review by the Town does not constitute approval of the plan design or accuracy and correctness of engineering calculations. Errors in the design or calculations remain the responsibility of the registered professional engineer whose stamp and signature are affixed to this document.

This review does not constitute approval of any private on-site improvements which may be shown. Construction cannot commence until all required drainage/traffic report(s), final development plan(s), special review(s), grading permit, and/or other permits are complete, approved and on file with the Town of Parker.

Town of Parker, Public Works Director	_____	Date
Town of Parker, Public Works Manager --Stormwater	_____	Date
Town of Parker, Public Works Manager --Transportation	_____	Date

REVISION	DATE	MM&D ENGINEERING SERVICES, INC.
COMMENTS	05/26/2015	
		William E. Miller, PE 13389 ENGINEERING
		CONSTRUCTION MANAGEMENT
		9125 N. Clydesdale Road PH (303) 908-0082 Castle Rock, Colorado 80108 FAX (303) 708-8399
		Boondocks Parker, Colorado Cover Sheet Construction Plans



Know what's below.
Call before you dig.

submittal 03/10/2015
 DATE 09/16/2014
 DES/DFI/CHK WEM/km
 PROJ. NO. 13-343
 SHEET 1 OF 24

CONSTRUCTION NOTES

1. All materials and construction shall be in conformance with the latest edition of the Colorado Department of Transportation Standard Specifications for Road and Bridge Construction, the latest edition of the Town of Parker Roadway Design and Construction Criteria Manual, and the Town of Parker Storm Drainage and Environmental Criteria Manual.
2. All materials and workmanship shall be subject to inspection by the Town of Parker Public Works Department. The Town reserves the right to accept or reject any such materials and workmanship that does not conform to its standards and specifications.
3. A preconstruction meeting shall be scheduled a minimum of 48 hours and a maximum of 96 hours prior to the start of construction. A preconstruction meeting will not be scheduled until the grading permit and all other necessary permits have been obtained.
4. A Development Review Engineer shall be contacted a minimum of 24 hours prior to a necessary inspection. If a Development Review Engineer is not available after proper notice of construction activity has been provided, the permittee may commence work in the Development Review Engineer's absence. However, Town of Parker reserves the right to reject the improvement if subsequent testing reveals an improper installation.
5. Location of existing utilities shall be verified by the contractor prior to actual construction. For information contact: Denver Inter-Utility Group, 303-534-6700 or 1-800-922-1987. The contractor shall field verify size and horizontal and vertical locations of existing facilities prior to construction, and notify the engineer of any discrepancies.
6. The contractor shall have one (1) signed copy of the plans, approved by the Town of Parker Public Works Director, and one (1) copy of the Roadway Design and Construction Criteria at the job site at all times.
7. All proposed street cuts to existing pavements for utilities, storm sewer or for other purposes are listed and referenced below:
WATER AND SANITARY SEWER – SHEET 3
STORM SEWER – SHEETS 3, 14-16
8. A plan for traffic control during construction shall be submitted to the Town of Parker for acceptance with the Right-of-Way Permit Use application. A permit will not be issued without an approved traffic control plan for use during construction.
9. All trenches shall be adequately supported and the safety of workers provided for as required by the most recent Occupational Safety and Health Administration (OSHA) "Safety and Health Regulations for Construction."
10. Compaction of all trenches must be attained and compaction test results submitted to the Development Review Engineer in preliminary form prior to paving and in final form prior to probationary acceptance.
11. The contractor is responsible for implementing and maintaining erosion and sediment control measures at all times during construction. The plan may be modified as field conditions warrant with approval from the Town of Parker Public Works Department.
12. The contractor shall provide, erect and maintain proper traffic control devices until the site is open to traffic. The contractor shall submit a traffic control plan to the Town of Parker Public Works Department for approval prior to construction.
13. Plans are approved for period of 1 (one) year from the date shown on the Town of Parker signature block. Plans shall be resubmitted to the Town for approval after 1 year. The cost of the plan re-review and re-acceptance will be charged back to the developer including all time and expenses of the Town of Parker Public Works Department.
14. Repair of any damage to existing improvements or landscaping is the responsibility of the contractor.
15. All damaged existing curb, gutter, and sidewalk shall be repaired prior to acceptance of completed improvements.
16. All construction activities must comply with the State of Colorado permitting process for "Stormwater Discharges Associated with Construction Activity." For information, please contact Colorado Department of Health, Water Quality Control Division, WQCD-PE-B2, 4300 Cherry Drive South, Denver, Colorado 80222-1530. Attention: Permits and Enforcement Section. Phone (303) 692-3500.
17. If dewatering is required, a state construction dewatering discharge permit is required for discharges to a storm sewer, channel, irrigation ditch, any street that is tributary to the aforementioned facilities, or any water of the United States.
18. All references to books, pages, maps, and the reception number are public documents on file with the County Clerk and Recorder's Office.

ROADWAY NOTES

1. Paving shall not commence until a soils report and pavement design is approved by the Engineering Division and subgrade compaction tests are submitted to and approved by the Development Review Engineer.
2. Standard Town of Parker Handicap Ramps are to be constructed at all curb returns and at all "T" intersections.
3. All stationing is based on centerline of roadways unless otherwise noted.
4. All elevations are on USGS DATUM with date. Range point or monument shall be shown on the construction plans.
5. Except where otherwise provided for in these plans and specifications, the Colorado Department of Highways Standard Specifications for Road and Bridge Construction, the Colorado Department of Highways M and S Standards, and the Town of Parker Roadway Design and Construction Criteria Manual, latest edition, shall apply.

STORM DRAINAGE INFRASTRUCTURE NOTES

1. All storm drainage improvements are subject to compliance with the Colorado Department of Transportation (CDOT) current edition of the Standard Specifications for Road and Bridge Construction, M & S Standards, and all standard special provisions currently used by CDOT, with the modifications set forth in the Town of Parker's Storm Drainage and Environmental Criteria Manual (SDECM), as amended.
2. The contractor shall comply with the "Colorado Water Quality Control Act" (Title 25, Article 8 CRS), the "Protection of Fishing Streams" Title 33, Article 5, CRS), the "Clean Water Act" (33 USC 1344), Cherry Creek Reservoir Control Regulation No. 72' (5 CCR 1002-72), the regulation promulgated, certification or permits issues, and the requirements presented in the SDECM Revision to Section 107 and the Construction BMP Plan. In the event of conflicts between these requirements and water quality control laws, rules, or regulations of other Federal, or State agencies, the more restrictive laws, rules, or regulations shall apply.
3. Inspections: Construction shall not begin until a grading permit has been issued for the project. The contractor shall notify the Town of Parker Engineering Department (Public Works) to schedule inspections a minimum of 48 hours prior the construction of all drainage infrastructure (storm sewers, inlets, manholes, energy dissipaters, riprap, grouted boulders, detention pond outlet structures, forebays, trickle channels, etc). Failure to notify the engineering department for inspections may result in nonacceptance of the infrastructure by the Town. Urban Drainage and Flood Control District must also be notified in a similar manner for all maintenance eligible drainage infrastructures (consult with Stormwater Engineering Division).
4. Structural backfill (CDOT Class 1) shall be compacted to conform to CDOT Standard Specification 203.03. Structural backfill (CDOT Class 2) shall conform to CDOT Standard Specification 203.07. At the contractor's option, Structural Backfill (Squeeze) meeting the gradation requirements contained in Revision of Section 206 of the CDOT Standard Specifications as presented in the SDECM, may be substituted for Structure backfill (Class 1) or Class 2) for backfilling of culvert pipes, storm sewer pipes, manholes and inlet structures; however, the top 2 feet below subgrade elevation shall be the required embankment material.
5. All excavations shall meet OSHA requirements.
6. Testing: Probationary acceptance of storm drainage improvements will be contingent upon satisfactory testing results. In all cases where tests indicate compaction less than that required by Town specifications, additional compaction and tests will be required until the specifications are met. Frequency of testing will be as follows:
-1 test for subgrade and 1 test for backfill at every above ground appurtenance (manholes, inlets, etc)
-1 test every 200 LF of mainline trench every 1 foot of backfill lift and within 1 foot from all structures.
7. Allowable storm sewer conduit material within the Town of Parker shall be limited to Reinforced Concrete Pipe (RCP) conforming to CDOT Standard Specification 706.02.
8. All RCP joints shall be manufactured in accordance with ASTM C443. Rubber gaskets shall be used on all pipe joints conforming to ASTM C443. All RCP sections shall be joined in such a manner that the ends are fully entered and the inner surfaces are reasonable flush. Average joint gap that exceeds 1/2 inch shall be filled with an approved flexible plastic sealant.
9. Joint restraints and toe-walls, conforming to CDOT M&S Standard Plan No. M-601-11 shall be used on all RCP flared end section outfalls.
10. Epoxy coated rebar shall be used as reinforcing steel on all storm inlets. Reference CDOT M&S Standard Plan No. M-604-10, 11, 12, and 13.
11. CDOT Class D concrete shall be used for all concrete drainage structures.
12. Pre-cast inlets and manhole bases shall not be used within the Town of Parker Right-of-way, with the exception of CDOT Type C and D inlets.
13. Two- (2) manhole access points are required on all Type "R" curb inlets greater than or equal to ten (10) feet in length as presented in CDOT M&S Standard Plan No. M-604-12.
14. All grouting (boulders, riprap) shall be in accordance with the Revision of Section 506 of the CDOT Standard Specifications as presented in the SDECM.
15. All boulders and riprap shall be selected and placed in accordance with the Revision of Section 506 of the CDOT Standard Specifications as presented in the SDECM.
16. Contractor shall refer to the Town of Parker's Construction Best Management Practices details and notes for all requirements relating to re-vegetation, sediment and erosion control requirements for construction activities.

SIGNAGE AND STRIPING NOTES

1. All traffic control devices shall conform to the most recent version of the federal Manual on Uniform Traffic Control Devices (MUTCD), Colorado Supplemental MUTCD, and the Town of Parker Roadway Design and Construction Criteria Manual. Further specifications and illustrations are located in the Colorado Department of Transportation (CDOT) M and S Standards.
2. A field inspection of location and installation of all signs and markings shall be performed by the Town of Parker.
3. The contractor installing signs shall be responsible for the locating and protecting of all underground utilities.
4. Type III (lighted) barricades shall be set at the ends of roadways separating finished (and/or accepted) and unfinished construction areas and shall be maintained by the contractor/developer. A "Road Closed Ahead" and "To Be Extended" warning signs shall be installed appropriately in advance of the Type III barricades.
5. Special care shall be taken in sign locations to ensure an unobstructed view of each sign.
6. Where stop sign control is appropriate, 36 inch stop signs shall be used for approaches to any roadway that is classified as a collector or greater.
7. A 7 foot minimum post length shall be maintained from the bottom of the sign panel to the ground. This requirement for vertical clearance is for all signs.
8. Delineation of roadways shall be as specified in the Colorado Department of Transportation M and S Standards.
9. Raised median island noses shall have R4-7 signs at each end and a 4'x12' high intensity yellow sign blank located midway between the R4-7 sign and finished grade on each post.
10. Signage and striping has been determined by information available at the time of review. Prior to the initiation of any warranty period, the Town of Parker reserves the right to require modifications to existing, or installation of, additional signage and/or pavement marking if it is determined that conditions warrant such modification according to the MUTCD or the CDOT M and S Standards. All signage and striping shall fall under the requirements of the two year warranty period for new construction. Additionally, all pavement markings shall not lift or peel during the first year after installation.
11. Diamond grade material shall be used on all stop signs and overhead signs. All other roadside traffic control devices shall use high intensity grade sheeting. No fluorescent yellow green sheeting shall be used unless specifically approved by the Town of Parker.
12. All street name signs shall be high intensity, extruded, green and white blades. Arterial and collector street name signs shall be 9 inch blades and have mixed case lettering. Local street name signs shall be 6 inches blades with mixed case lettering.
13. All layouts for internally illuminated street name signs shall be submitted to the Town for review and approval prior to fabrication.
14. All removed signs shall be returned to the Town of Parker.
15. Crosswalks: Shall be constructed using preformed thermo-plastic or an approved equal.

Shall be Longitudinal 2 feet by 10 feet (Continental) type or other approved by the Town of Parker.
Shall line up with handicap ramps.

Shall be centered within lanes and placed on lane and curb lines so as to avoid vehicle wheel paths.
16. All pavement marking material (including words and symbols) shall be as follows:
For Concrete Surface:

Long line markings (channelization lines, skips, etc.) shall be epoxy paint.
Other paint may be used for temporary application only when approved by the Town of Parker.

Words, symbols, and crosswalks/stop bars shall be methyl-methacrylate, preformed thermoplastic (90 mil), preformed plastic (90 mil), inlayed tape (STAMARK), or as specified.
(Sand or water blast curing compound prior to installation of markings.)

For Asphalt Surface:
Long line markings (channelization lines, skips, etc.) shall be epoxy paint.
Other paint may be used for temporary application only when approved by the Town of Parker.

Words, symbols, and crosswalks/stop bars shall be hot applied thermoplastic (90 mil), preformed plastic (90 mil), inlayed tape (STAMARK), Methyl-Mythacrylate, or as specified.

17. Inspection and approval of striping and crosswalk layout to be done by Town of Parker Development Review Engineer (call 303-840-9546) prior to application of final striping.

GENERAL NOTES:

- 1) MM&D ENGINEERING SERVICES, INC. SHALL BE NOTIFIED WITHIN 24HRS. OF DISCOVERY OF ANY DEVIATION TO THE PLANS.
- 2) THE CONTRACTOR SHALL FURNISH THE ENGINEER "AS CONSTRUCTED" LOCATIONS OF FACILITIES INSTALLED. THIS IN TURN SHALL BE USED WITH ADDITIONAL INFORMATION FROM THE ENGINEER TO CREATE "AS CONSTRUCTED" DRAWINGS TO BE SUBMITTED TO THE TOWN OF PARKER.

REVISION	DATE	MM&D ENGINEERING SERVICES, INC.	William E. Miller, PE 13389 ENGINEERING CONSTRUCTION MANAGEMENT 9125 N. Clydesdale Road PH (303) 908-0082 Castle Rock, Colorado 80108 FAX (303) 708-8399
COMMENTS	05/26/2015		
		Boondocks Parker, Colorado Notes Construction Plans	submittal 03/10/2015 DATE 09/16/2014 DES/DET/CHK WEM/km PROJ. NO. 13-343 SHEET 2 OF 24



Know what's below.
Call before you dig.

The Town of Parker review constitutes general compliance with the Town's Standards and approved variances, subject to these plans being stamped, signed, and dated by the professional engineer of record. Review by the Town does not constitute approval of the plan design or accuracy and correctness of engineering calculations. Errors in the design or calculations remain the responsibility of the registered professional engineer whose stamp and signature are affixed to this document.

This review does not constitute approval of any private on site improvements which may be shown. Construction cannot commence until all required drainage/traffic report(s), final development plan(s), special review(s), grading permit, and/or other permits are complete, approved and on file with the Town of Parker.

Town of Parker, Public Works Director	Date
Town of Parker, Public Works Manager - Stormwater	Date
Town of Parker, Public Works Manager - Transportation	Date

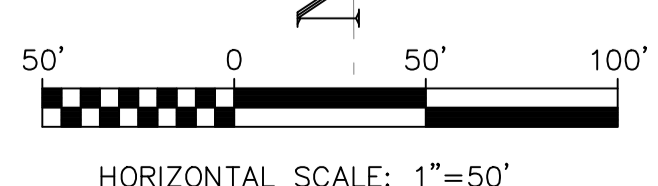
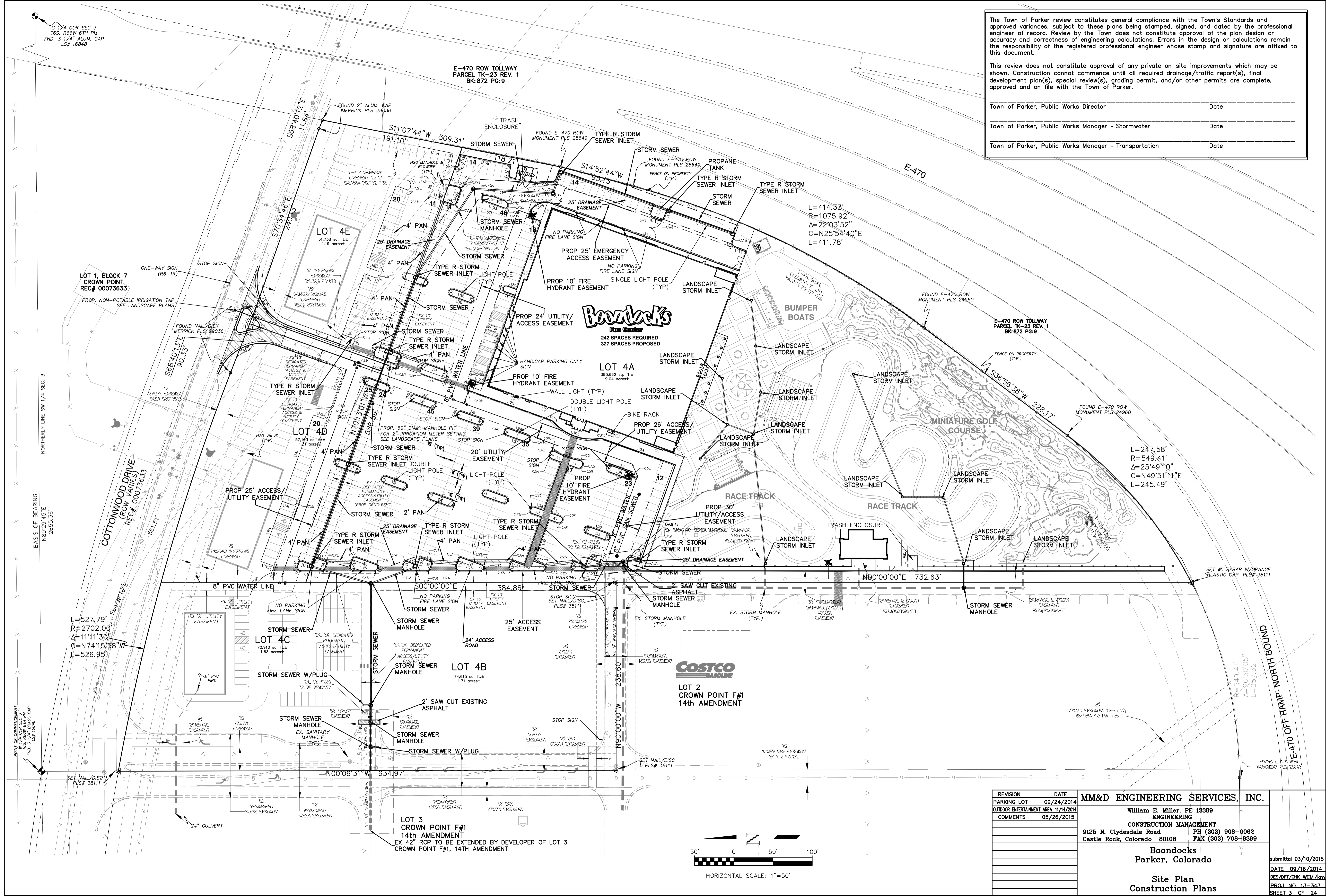

REVISION	DATE	MM&D ENGINEERING SERVICES, INC.
PARKING LOT	09/24/2014	William E. Miller, PE 13389 ENGINEERING
OUTDOOR ENTERTAINMENT AREA	11/14/2014	CONSTRUCTION MANAGEMENT
COMMENTS	05/26/2015	8125 N. Clydesdale Road PH (303) 908-0082 Castle Rock, Colorado 80108 FAX (303) 708-8399
		Boondocks Parker, Colorado
		Site Plan Construction Plans

submittal 03/10/2015
DATE 09/16/2014
DES/DFI/CHK WEM/km
PROJ. NO. 13-343
SHEET 3 OF 24

Flowline Curve Table

Curve #	Length	Radius	Delta
C1	14.137	4.500	090.0000
C2	14.137	4.500	180.0000
C3	14.137	4.500	180.0000
C4	14.137	4.500	180.0000
C5	14.137	4.500	180.0000
C6	14.137	4.500	180.0000
C7	14.137	4.500	180.0000
C8	14.137	4.500	180.0000
C9	6.128	5.000	070.2170
C10	9.580	5.000	109.7830
C11	4.712	3.000	090.0000
C12	4.712	3.000	090.0000
C13	3.921	2.500	090.0000
C14	4.712	3.000	090.0000
C15	6.128	5.000	070.2170
C16	9.580	5.000	109.7830
C17	4.712	3.000	090.0000
C18	6.128	5.000	070.2170
C19	9.580	5.000	109.7830
C20	4.712	3.000	090.0000

Curve #	Length	Radius	Delta
C21	3.921	2.500	090.0000
C22	4.712	3.000	090.0000
C23	6.128	5.000	070.2170
C24	9.580	5.000	109.7830
C25	9.580	5.000	109.7830
C26	4.712	3.000	090.0000
C27	4.712	3.000	090.0000
C28	6.128	5.000	070.2170
C29	14.137	4.500	180.0000
C30	14.137	4.500	180.0000
C31	14.137	4.500	180.0000
C32	14.137	4.500	180.0000
C33	7.969	4.500	090.0000
C34	7.969	4.500	090.0000
C35	7.969	4.500	090.0000
C36	33.814	104.543	018.4223
C37	7.969	4.500	090.0000
C38	6.128	5.000	090.0000
C39	9.580	5.000	109.7830
C40	7.969	4.500	090.0000

Curve #	Length	Radius	Delta
C41	4.712	3.000	090.0000
C42	6.128	5.000	070.2170
C43	9.580	5.000	109.7830
C44	4.712	3.000	090.0000
C45	7.969	4.500	090.0000
C46	14.137	4.500	180.0000
C47	14.137	4.500	180.0000
C48	14.137	4.500	180.0000
C49	14.137	4.500	180.0000
C50	14.137	4.500	180.0000
C51	14.137	4.500	180.0000
C52	14.137	4.500	180.0000
C53	14.137	4.500	180.0000
C54	7.969	4.500	090.0000
C55	3.921	2.500	090.0000
C56	14.137	4.500	180.0000
C57	3.921	2.500	090.0000
C58	4.231	5.000	048.4852
C59	38.039	43.000	090.8855
C60	92.794	60.000	088.8121

Line #	Length	Direction
L1	25.000	N19° 46' 58.79"E
L2	25.000	S19° 46' 58.79"W
L3	25.000	N19° 46' 58.79"E
L4	25.000	S19° 46' 58.79"W
L5	25.000	N19° 46' 58.79"E
L6	25.000	S19° 46' 58.79"W
L7	25.000	N19° 46' 58.79"E
L8	25.000	S19° 46' 58.79"W
L9	25.505	S00° 00' 00.00"E
L10	4.390	N70° 13' 01.21"W
L11	14.000	N19° 46' 58.79"E
L12	10.000	N70° 13' 01.21"W
L13	14.000	N19° 46' 58.79"E
L14	5.756	S70° 13' 01.21"E
L15	10.230	N70° 13' 01.21"W
L16	28.500	N19° 46' 58.79"E
L17	1.098	S70° 13' 01.21"E
L18	25.505	S00° 00' 00.00"E
L19	5.437	S70° 13' 01.21"E
L20	25.505	S00° 00' 00.00"E

Line #	Length	Direction
L21	4.070	N70° 13' 01.21"W
L22	14.000	N19° 46' 58.79"E
L23	10.000	N70° 13' 01.21"W
L24	14.000	N19° 46' 58.79"E
L25	9.550	N70° 13' 01.21"W
L26	28.505	N19° 46' 58.79"E
L27	0.417	S70° 13' 01.21"E
L28	25.505	S00° 00' 00.00"E
L29	2.882	N70° 13' 01.21"W
L30	14.000	N19° 46' 58.79"E
L31	14.000	N70° 13' 01.21"W
L32	10.000	N70° 13' 01.21"W
L33	14.000	N19° 46' 58.79"E
L34	4.249	S70° 13' 01.21"E
L35	25.000	N19° 46' 58.79"E
L36	25.000	S19° 46' 58.79"W
L37	25.000	N19° 46' 58.79"E
L38	25.000	S19° 46' 58.79"W
L39	12.500	N19° 46' 58.79"E
L40	65.000	N70° 13' 01.21"W
L41	12.500	S19° 46' 58.79"W

Line #	Length	Direction
L42	1.414	N70° 13' 01.21"W
L43	1.414	S70° 13' 01.21"E
L44	12.500	S19° 46' 58.79"W
L45	65.000	S70° 13' 01.21"E
L46	12.500	N19° 46' 58.79"E
L47	12.500	S19° 46' 58.79"W
L48	56.000	S70° 13' 01.21"E
L49	14.000	N19° 46' 58.79"E
L50	0.801	S70° 13' 01.21"E
L51	36.132	S00° 00' 00.00"E
L52	4.030	N70° 13' 01.21"W
L53	14.000	N19° 46' 58.79"E
L54	65.000	N70° 13' 01.21"W
L55	12.500	S19° 46' 58.79"W
L56	25.000	N19° 46' 58.79"E
L57	25.000	S19° 46' 58.79"W
L58	25.000	N19° 46' 58.79"E
L59	25.000	S19° 46' 58.79"W
L60	25.000	N19° 46' 58.79"E
L61	25.000	S19° 46' 58.79"W

Curve #	Length	Radius	Delta
C61	15.708	10.000	090.0000
C62	7.854	5.000	090.0000
C63	7.854	5.000	090.0000
C64	7.854	5.000	090.0000
C65	7.854	5.000	090.0000
C66	7.854	5.000	090.0000
C67	7.854	5.000	090.0000
C68	7.854	5.000	090.0000
C69	7.854	5.000	090.0000
C70	7.854	5.000	090.0000
C71	92.708	60.000	088.5298
C72	16.360	10.896	086.0282
C73	3.921	2.500	090.0000
C74	4.712	3.000	090.0000
C75	4.712	3.000	090.0000
C76	3.921	2.500	090.0000
C77	10.306	6.000	098.4118
C78	14.137	4.500	180.0000
C79	14.137	4.500	180.0000
C80	14.137	4.500	180.0000

Curve #	Length	Radius	Delta
C81	14.137	4.500	180.0000
C82	1.762	12.000	028.4116
C83	10.210	6.500	090.0000
C84	3.921	2.500	090.0000
C85	5.498	3.500	090.0000
C86	4.984	3.500	081.5884
C87	3.921	2.500	090.0000
C88	3.921	2.500	090.0000
C89	11.079	5.000	136.9522
C90	10.901	30.000	020.8184
C91	15.374	51.000	017.2116
C92	6.128	4.500	078.0413
C93	7.069	4.500	090.0000
C94	7.069	4.500	090.0000
C95	7.069	4.500	090.0000
C96	7.069	4.500	090.0000
C97	7.069	4.500	090.0000
C98	7.069	4.500	090.0000
C99	7.069	4.500	090.0000
C100	9.984	9.984	049.8157
C101	7.069	4.500	090.0000
C102	7.207	15.000	027.5271
C103	61.971	64.500	055.0541
C104	7.207	15.000	027.5271

Curve #	Length	Radius	Delta
C105	7.069	4.500	090.0000
C106	7.069	4.500	090.0000
C107	13.568	4.500	180.0000
C108	7.271	4.500	092.5793
C109	35.762	22.344	091.8212
C110	11.797	5.011	134.8993
C111	11.435	5.000	131.0357
C112	19.833	78.000	014.4220
C113	11.079	5.000	136.9522
C114	19.588	78.000	014.3888
C115	4.164	S70° 13' 01.21"E	
C116	4.272	3.000	081.5884
C117	7.729	4.500	098.4116
C118	7.069	4.500	090.0000

Line #	Length	Direction
L62	25.000	N19° 46' 58.79"E
L63	25.000	S19° 46' 58.79"W
L64	5.000	S70° 13' 01.21"E
L65	15.500	S19° 46' 58.79"W
L66	108.000	S70° 13' 01.21"E
L67	13.500	N19° 46' 58.79"E
L68	13.500	S19° 46' 58.79"W
L69	81.000	S70° 13' 01.21"E
L70	15.500	N19° 46' 58.79"E
L71	4.164	S70° 13' 01.21"E
L72	13.000	S70° 13' 01.21"E
L73	25.000	S19° 46' 58.79"W
L74	5.000	N70° 13' 01.21"W
L75	25.000	N19° 46' 58.79"E
L76	5.000	S70° 13' 01.21"E
L77	5.000	S70° 13' 01.21"E
L78	25.000	S19° 46' 58.79"W
L79	5.000	N70° 13' 01.21"W
L80	25.000	N19° 46' 58.79"E
L81	5.000	S70° 13' 01.21"E
L82	75.968	N19° 46' 58.79"E

Line #	Length	Direction
L83	0.500	N70° 13' 01.21"W
L84	15.500	S19° 46' 58.79"W
L85	82.000	N70° 13' 01.21"W
L86	15.000	N19° 46' 58.79"E
L87	3.000	N70° 13' 01.21"W
L88	15.000	S19° 46' 58.79"W
L89	109.999	N70° 13' 01.21"W
L90	15.500	N19° 46' 58.79"E
L91	3.119	N70° 13' 01.53"E
L92	25.000	N19° 46' 58.79"E
L93	25.000	N19° 46' 58.79"E
L94	25.000	S19° 46' 58.79"W
L95	25.000	N19° 46' 58.79"E
L96	25.000	S19° 46' 58.79"W
L101	12.959	N19° 46' 58.79"E
L102	0.059	S70° 13' 01.21"E
L103	28.500	S19° 46' 58.79"W
L104	0.444	N70° 13' 01.21"W
L105	10.410	N11° 22' 16.92"E
L106	13.499	S78° 37' 44.35"E
L107	5.000	N11° 22' 15.88"E

Line #	Length	Direction
L108	13.499	N78° 37' 44.35"W
L109	65.000	N11° 22' 15.35"E
L110	11.500	S78° 37' 44.11"E
L111	25.568	N11° 22' 15.78"E
L112	12.705	N70° 13' 01.22"W
L113	128.000	N19° 46' 58.79"E
L114	11.500	S70° 13' 01.21"E
L115	9.000	N19° 46' 58.79"E
L116	11.500	N70° 13' 01.21"W
L117	92.000	N19° 46' 58.79"E
L118	11.500	S70° 13' 01.21"E
L119	16.249	N19° 46' 58.79"E
L120	13.416	S00° 00' 00.00"E
L121	1.421	N70° 13' 01.21"W
L122	11.500	N19° 46' 58.79"E
L123	129.000	N70° 13' 01.21"W
L124	96.258	S19° 46' 58.79"W
L125	108.758	S19° 46' 58.79"W
L126	5.000	N70° 13' 01.21"W
L127	13.500	N19° 46' 58.79"E

Line #	Length	Direction
L128	120.000	N70° 13' 01.21"W
L129	13.500	S19° 46' 58.79"W
L130	13.500	N19° 46' 58.79"E
L131	92.000	N70° 13' 01.21"W
L132	12.484	S19° 46' 58.79"W
L133	251.749	N19° 46' 58.79"E
L134	43.834	N11° 22' 15.78"E
L135	79.864	N19° 46' 58.79"E
L136	22.736	S69° 00' 27.53"E
L137	25.505	S00° 00' 00.00"E
L138	15.000	S19° 50' 24.60"W
L139	13.500	N70° 09' 35.40"W
L140	0.554	N70° 09' 35.40"W
L141	15.216	N11° 25' 42.73"E
L142	11.856	N11° 25' 42.73"E
L143	14.533	S70° 09' 35.4

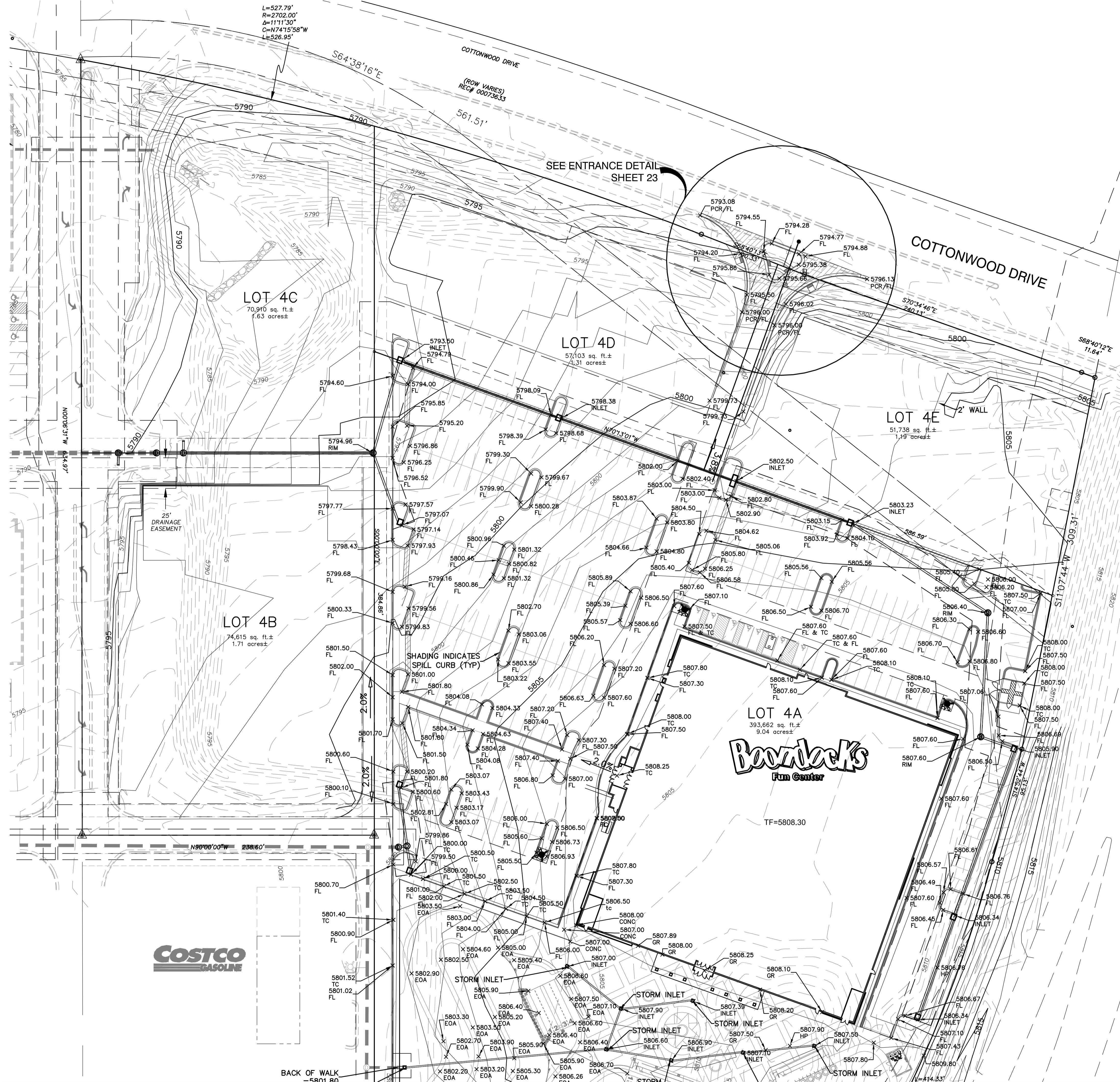
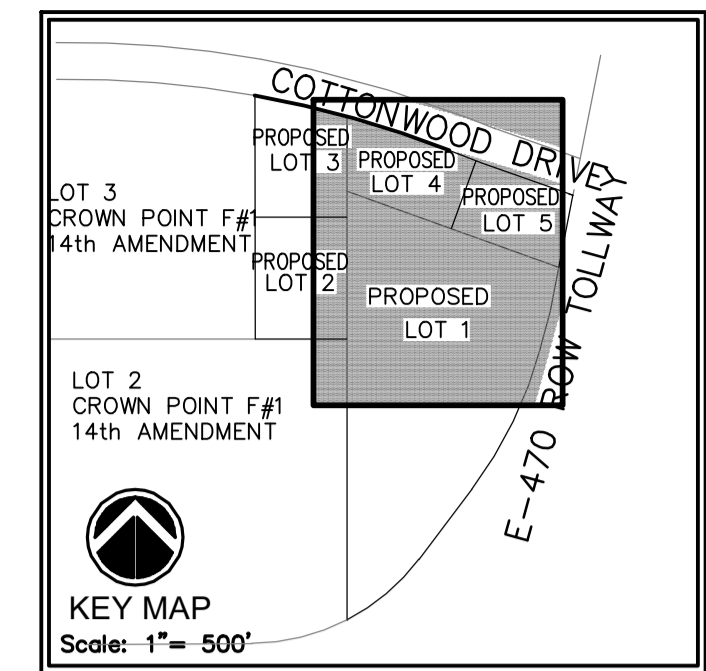

The Town of Parker review constitutes general compliance with the Town's Standards and approved variances, subject to these plans being stamped, signed, and dated by the professional engineer of record. Review by the Town does not constitute approval of the plan design or accuracy and correctness of engineering calculations. Errors in the design or calculations remain the responsibility of the registered professional engineer whose stamp and signature are affixed to this document.

This review does not constitute approval of any private on site improvements which may be shown. Construction cannot commence until all required drainage/traffic report(s), final development plan(s), special review(s), grading permit, and/or other permits are complete, approved and on file with the Town of Parker.

Town of Parker, Public Works Director	Date
Town of Parker, Public Works Manager - Stormwater	Date
Town of Parker, Public Works Manager - Transportation	Date

NOTES:
 LOT 4B TO LOT 4E, AS SHOWN ON THIS PLAN, ARE FOR REPRESENTATIONAL PURPOSES ONLY.
 EACH LOT SHALL SUBMIT A SEPARATE SITE PLAN FOR THE TOWN OF PARKER'S APPROVAL.

CONTOURS REFLECT PROPOSED SUB-GRADE ELEVATIONS BASED ON AN ASSUMED 4" ASPHALT OVER 8" BASE.

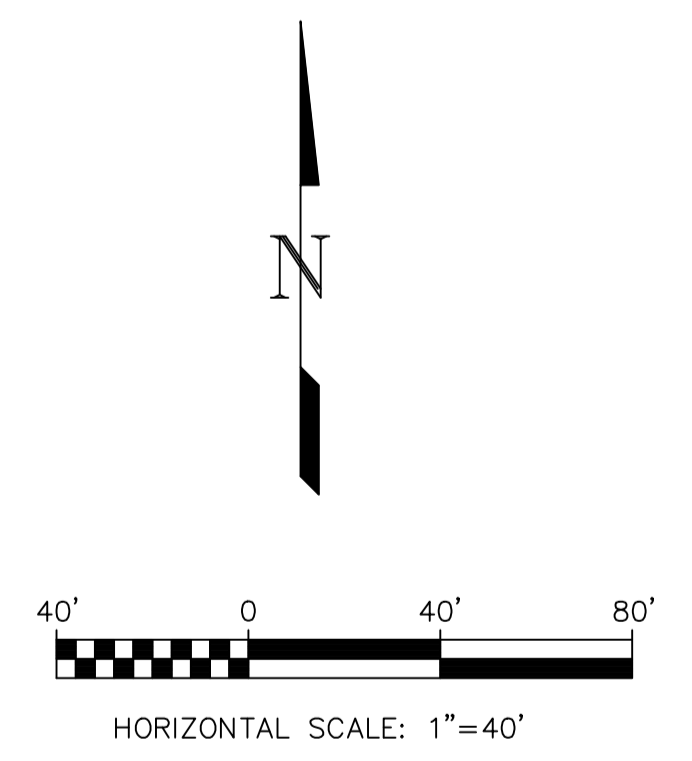

AREA OF DISTURBANCE: 741,500 SF

DIRT QUANTITIES (CU YD):

CUT	FILL	NET
19,161	26,983	7,822

REVISION	DATE	MM&D ENGINEERING SERVICES, INC. William E. Miller, PE 13389 ENGINEERING CONSTRUCTION MANAGEMENT 9125 N. Clydesdale Road PH (303) 908-0082 Castle Rock, Colorado 80108 FAX (303) 708-8399
PARKING LOT	09/24/2014	
COMMENTS	05/26/2015	
		Boondocks Parker, Colorado Grading Plan Construction Plans
		submittal 03/10/2015 DATE 09/16/2014 DES/CHK WEM/km PROJ. NO. 13-343 SHEET 5 OF 24

Matchline See Sheet 6

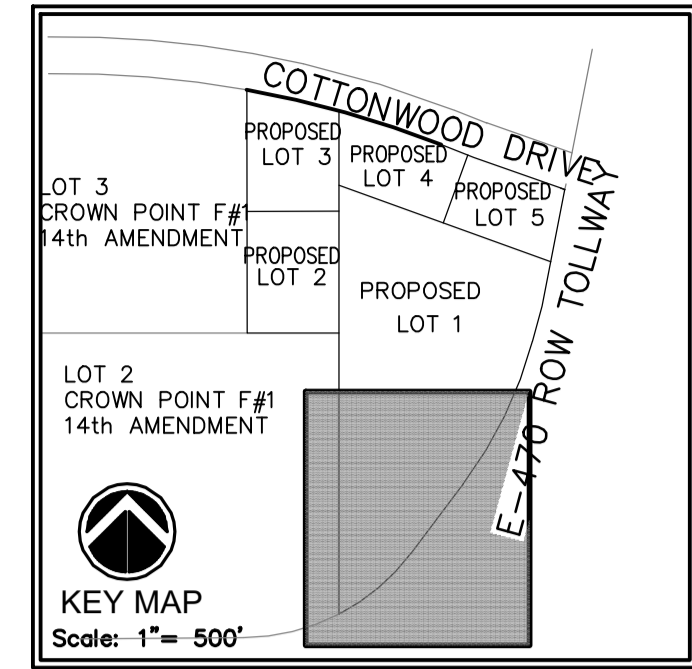

Matchline See Sheet 5

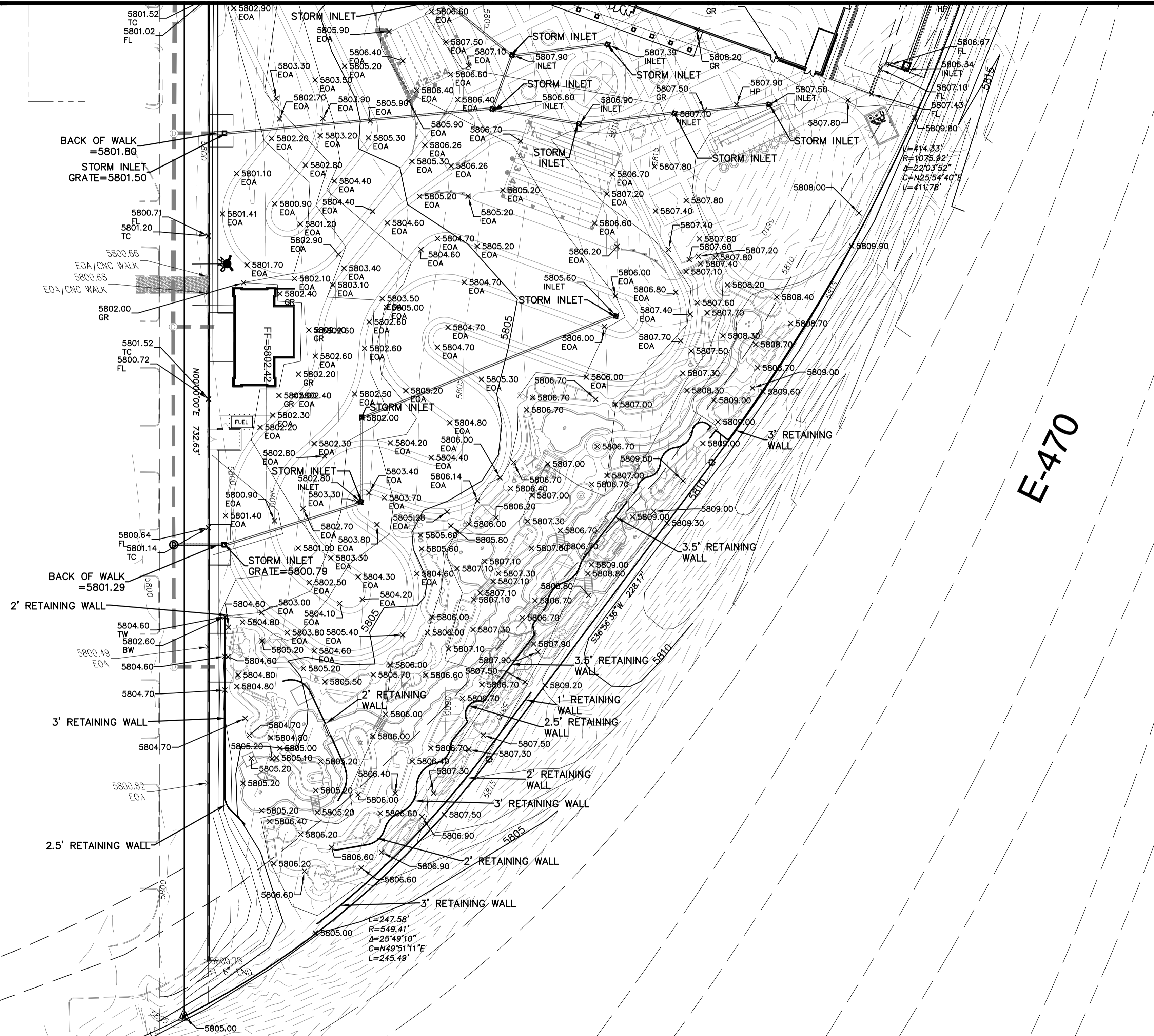

The Town of Parker review constitutes general compliance with the Town's Standards and approved variances, subject to these plans being stamped, signed, and dated by the professional engineer of record. Review by the Town does not constitute approval of the plan design or accuracy and correctness of engineering calculations. Errors in the design or calculations remain the responsibility of the registered professional engineer whose stamp and signature are affixed to this document.

This review does not constitute approval of any private on site improvements which may be shown. Construction cannot commence until all required drainage/traffic report(s), final development plan(s), special review(s), grading permit, and/or other permits are complete, approved and on file with the Town of Parker.

Town of Parker, Public Works Director	Date
Town of Parker, Public Works Manager - Stormwater	Date
Town of Parker, Public Works Manager - Transportation	Date

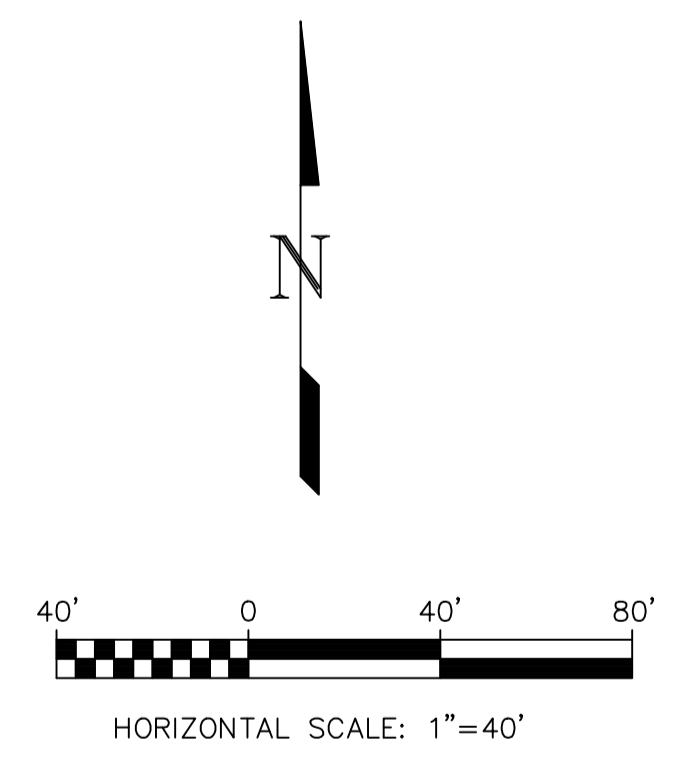







AREA OF DISTURBANCE: 741,500 SF

DIRT QUANTITIES (CU YD):

CUT	FILL	NET
19,161	26,983	7,822

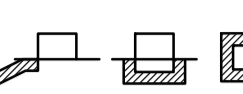
REVISION	DATE	MM&D ENGINEERING SERVICES, INC.
PARKING LOT	09/24/2014	
COMMENTS	05/26/2015	William E. Miller, PE 13389 ENGINEERING CONSTRUCTION MANAGEMENT 8125 N. Clydesdale Road PH (303) 908-0082 Castle Rock, Colorado 80108 FAX (303) 708-8399
		Boondocks Parker, Colorado Grading Plan Construction Plans
		submital 03/10/2015 DATE 09/16/2014 DES/CHK WEM/km PROJ. NO. 13-343 SHEET 6 OF 24

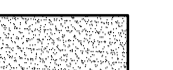
BMP LEGEND

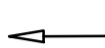
-  (CD) CHECK DAM
-  (CWA) CONCRETE WASHOUT AREA
-  (IP) INLET PROTECTION
-  (SF) SILT FENCE
-  (SSA) STABILIZED STAGING AREA
-  (VTC) VEHICLE TRACKING CONTROL
-  (LOC) LIMITS OF CONSTRUCTION
-  Flow Direction Arrow

Area Outside Limits of Construction
 SHADED AREAS OUTSIDE LIMITS OF CONSTRUCTION SHALL NOT BE DISTURBED. CONSTRUCTION FENCE OR CONSTRUCTION MARKERS TO DELINEATE LIMITS OF CONSTRUCTION SHALL BE INSTALLED PRIOR TO ANY OTHER WORK ON SITE.

The Town of Parker review constitutes general compliance with the Town's Standards and approved variances, subject to these plans being stamped, signed, and dated by the professional engineer of record. Review by the Town does not constitute approval of the plan design or accuracy and correctness of engineering calculations. Errors in the design or calculations remain the responsibility of the registered professional engineer whose stamp and signature are affixed to this document.

This review does not constitute approval of any private on site improvements which may be shown. Construction cannot commence until all required drainage/traffic report(s), final development plan(s), special review(s), grading permit, and/or other permits are complete, approved and on file with the Town of Parker.

Town of Parker, Public Works Director _____ Date _____
 Town of Parker, Public Works Manager - Stormwater _____ Date _____
 Town of Parker, Public Works Manager - Transportation _____ Date _____

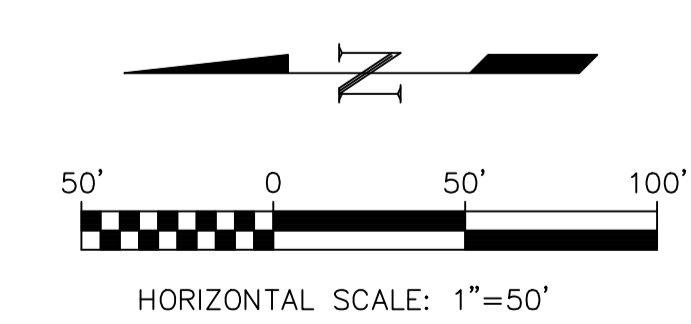
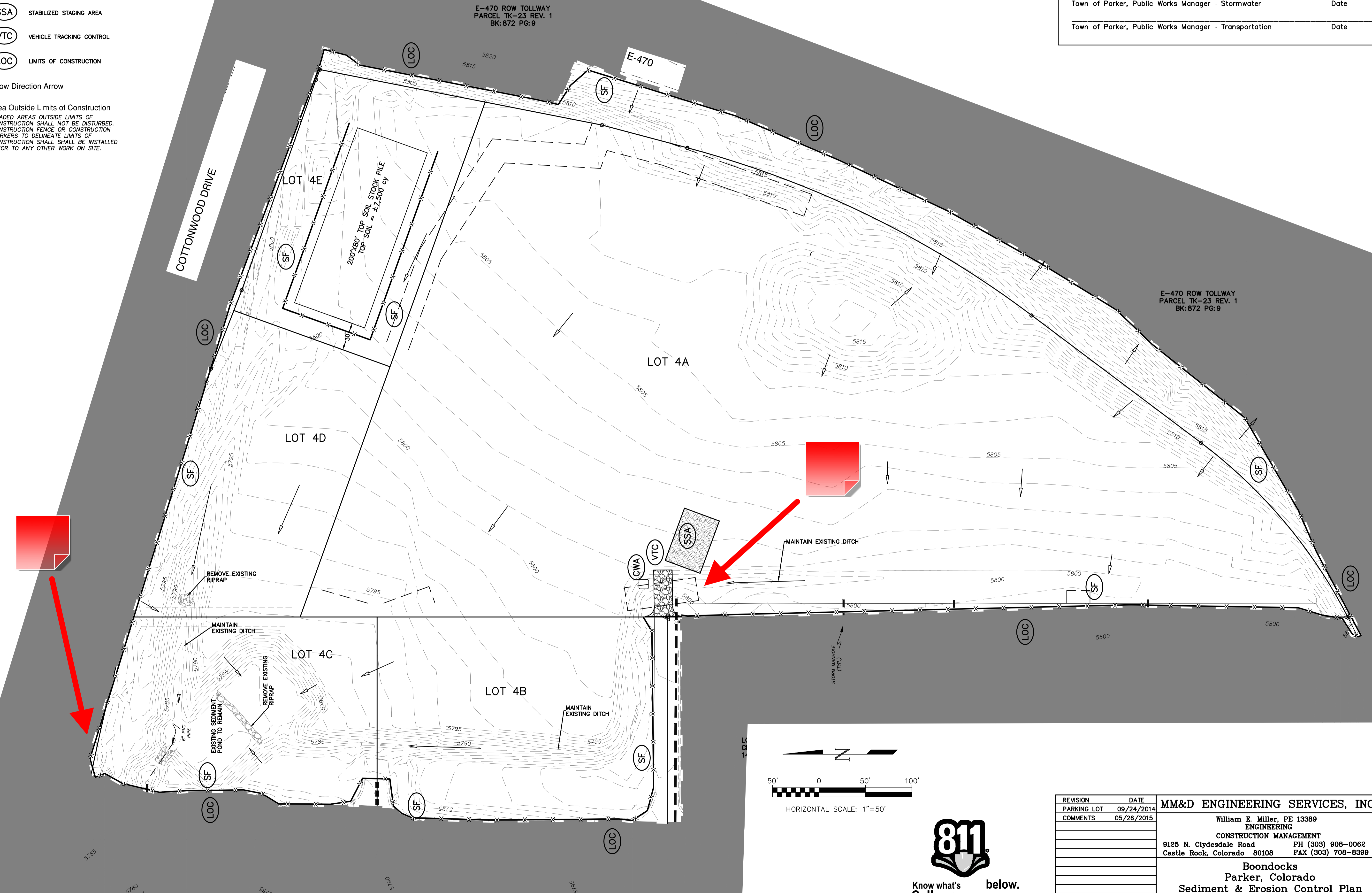









REVISION	DATE	MM&D ENGINEERING SERVICES, INC.
PARKING LOT	09/24/2014	William E. Miller, PE 13389
COMMENTS	05/26/2015	ENGINEERING
		CONSTRUCTION MANAGEMENT
		9125 N. Clydesdale Road PH (303) 908-0082
		Castle Rock, Colorado 80108 FAX (303) 708-8399
		Boondocks
		Parker, Colorado
		Sediment & Erosion Control Plan
		Initial Stage
		Construction Plans

DATE 09/16/2014
 DES/DFI/CHK. WEM/km
 PROJ. NO. 13-343
 SHEET 7 OF 24

The Town of Parker review constitutes general compliance with the Town's Standards and approved variances, subject to these plans being stamped, signed, and dated by the professional engineer of record. Review by the Town does not constitute approval of the plan design or accuracy and correctness of engineering calculations. Errors in the design or calculations remain the responsibility of the registered professional engineer whose stamp and signature are affixed to this document.

This review does not constitute approval of any private on site improvements which may be shown. Construction cannot commence until all required drainage/traffic report(s), final development plan(s), special review(s), grading permit, and/or other permits are complete, approved and on file with the Town of Parker.

Town of Parker, Public Works Director _____ Date _____
 Town of Parker, Public Works Manager - Stormwater _____ Date _____
 Town of Parker, Public Works Manager - Transportation _____ Date _____

-  (CWA) CONCRETE WASHOUT AREA
-  (DD) DIVERSION DITCH
-  (IP) INLET PROTECTION
-  (RS) ROCK SOCK
-  (SF) SILT FENCE
-  (SSA) STABILIZED STAGING AREA
-  (VTC) VEHICLE TRACKING CONTROL
-  (LOC) LIMITS OF CONSTRUCTION
-  Flow Direction Arrow

Area Outside Limits of Construction
 SHADED AREAS OUTSIDE LIMITS OF CONSTRUCTION SHALL NOT BE DISTURBED. CONSTRUCTION FENCE OR CONSTRUCTION MARKERS TO DELINEATE LIMITS OF CONSTRUCTION SHALL BE INSTALLED PRIOR TO ANY OTHER WORK ON SITE.

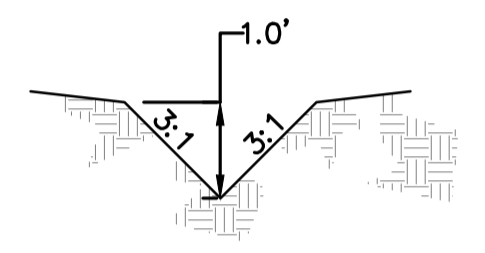

TYPICAL DIVERSION DITCH NOT TO SCALE

SEDIMENT POND
 REQUIRED VOLUME
 9.4 AC.
 UDFCD SB
 3600cf x 9.4 ac = 33,33,840 ft(3)
 EXISTING SEDIMENT BASIN
 ELEVATION WS = 5785.60
 ACTUAL VOLUME = 34,000

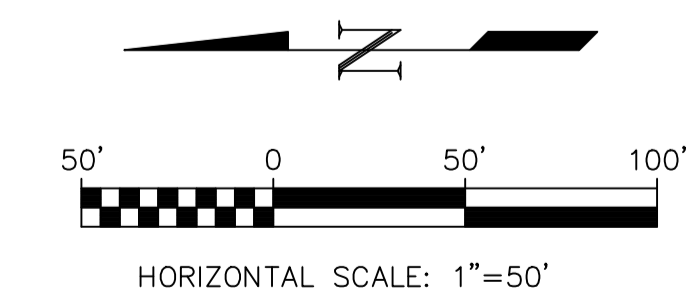
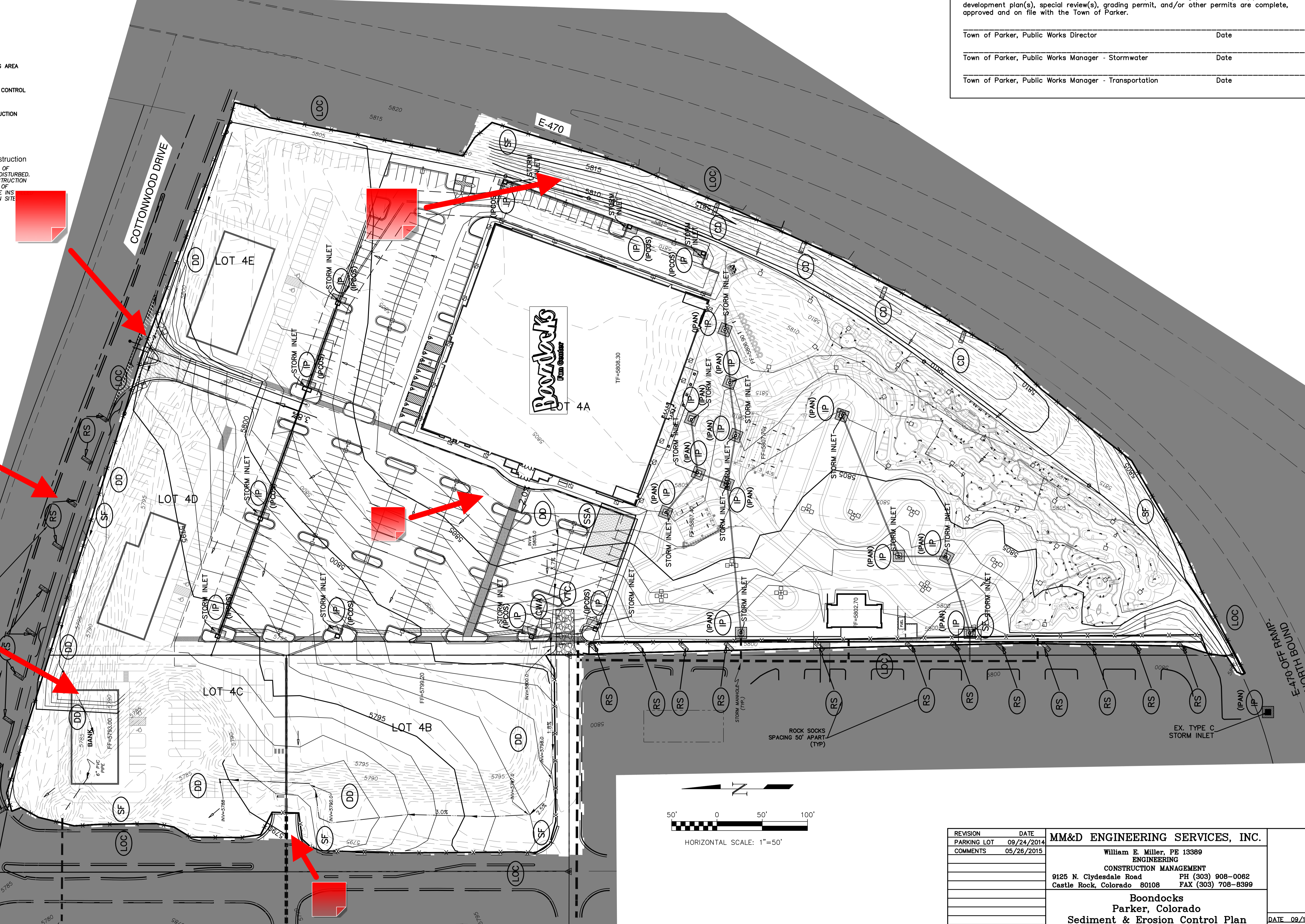
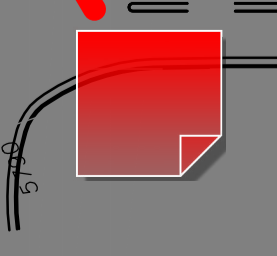
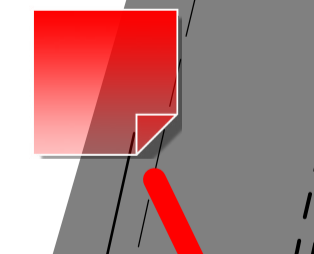
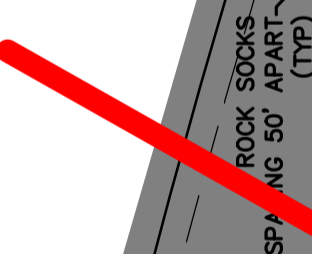
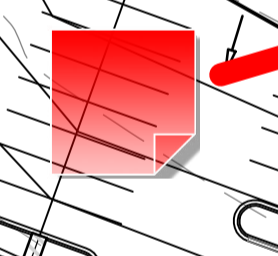
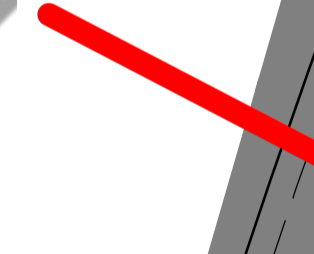
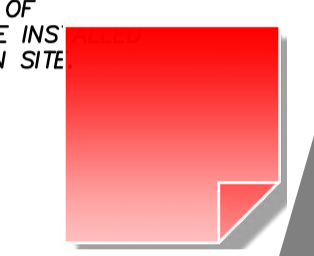

REVISION	DATE	MM&D ENGINEERING SERVICES, INC.
PARKING LOT	09/24/2014	William E. Miller, PE 13389
COMMENTS	05/26/2015	ENGINEERING
		CONSTRUCTION MANAGEMENT
		9125 N. Clydesdale Road PH (303) 908-0082
		Castle Rock, Colorado 80108 FAX (303) 708-8399
		Boondocks
		Parker, Colorado
		Sediment & Erosion Control Plan
		Interim Stage
		Construction Plans

DATE 09/16/2014
 DES/DF1/CHK. WEM/km
 PROJ. NO. 13-343
 SHEET 8 OF 24

The Town of Parker review constitutes general compliance with the Town's Standards and approved variances, subject to these plans being stamped, signed, and dated by the professional engineer of record. Review by the Town does not constitute approval of the plan design or accuracy and correctness of engineering calculations. Errors in the design or calculations remain the responsibility of the registered professional engineer whose stamp and signature are affixed to this document.

This review does not constitute approval of any private on site improvements which may be shown. Construction cannot commence until all required drainage/traffic report(s), final development plan(s), special review(s), grading permit, and/or other permits are complete, approved and on file with the Town of Parker.

Town of Parker, Public Works Director _____ Date _____
 Town of Parker, Public Works Manager - Stormwater _____ Date _____
 Town of Parker, Public Works Manager - Transportation _____ Date _____

- (SMC) SEEDING, MULCHING AND CRIMPING
- (RS) ROCK SOCK
- (RSS) ROCK SOCK IN SWALE
- (SF) SILT FENCE
- (SCL) SEDIMENT CONTROL LOG
- (SSA) STABILIZED STAGING AREA
- (VTC) VEHICLE TRACKING CONTROL
- (LOC) LIMITS OF CONSTRUCTION

Flow Direction Arrow

Area Outside Limits of Construction
 SHADED AREAS OUTSIDE LIMITS OF CONSTRUCTION SHALL NOT BE DISTURBED. CONSTRUCTION FENCE OR CONSTRUCTION MARKERS TO DELINEATE LIMITS OF CONSTRUCTION SHALL BE INSTALLED PRIOR TO ANY OTHER WORK ON SITE.

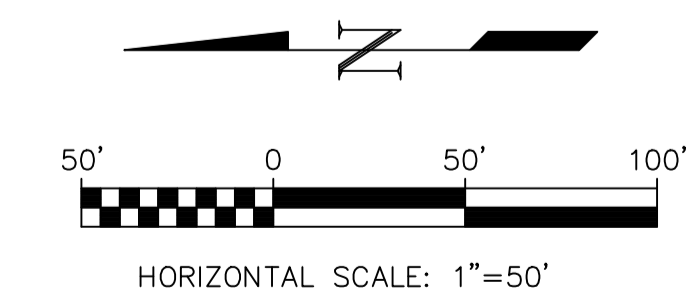
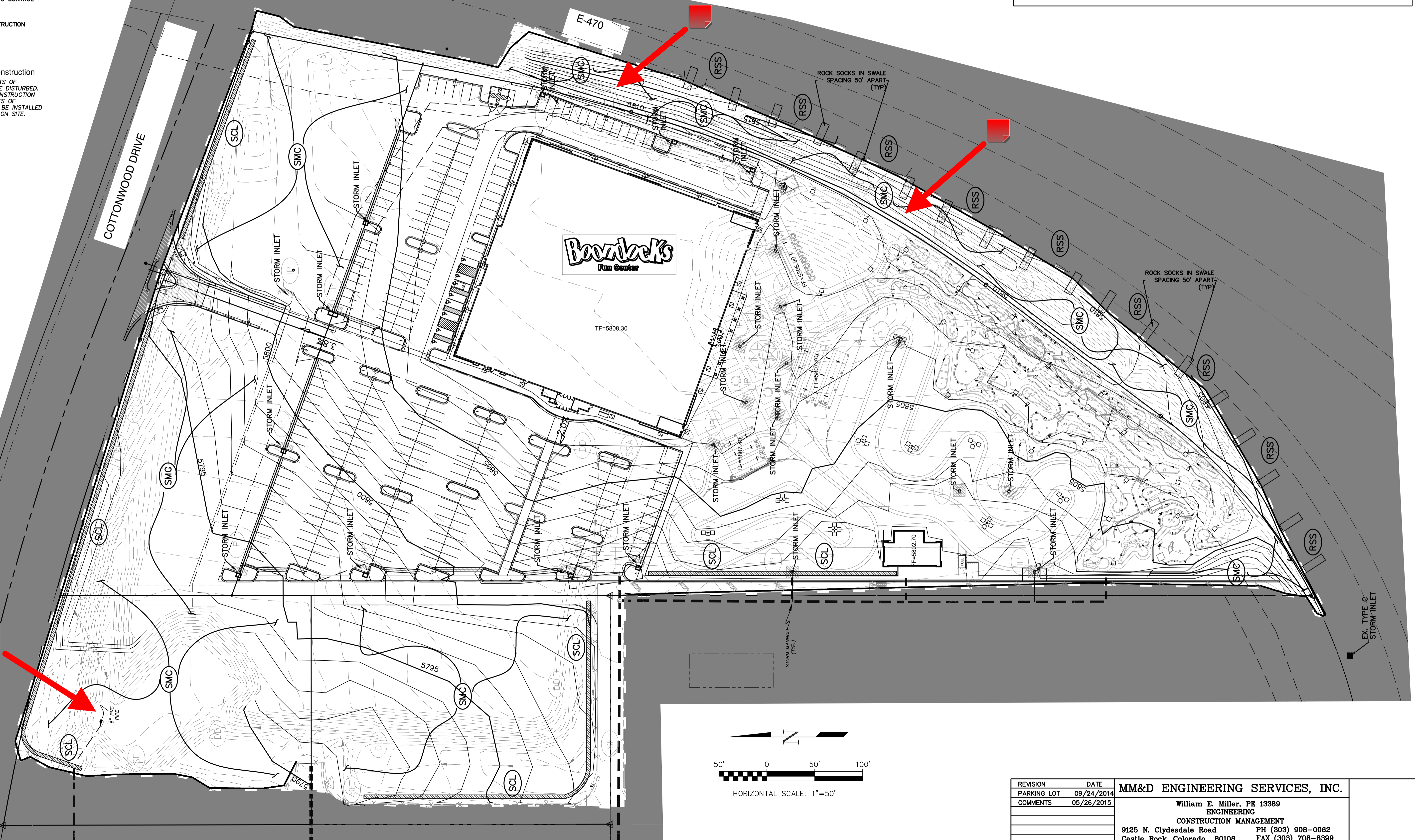

REVISION	DATE	MM&D ENGINEERING SERVICES, INC.
PARKING LOT	09/24/2014	
COMMENTS	05/26/2015	
		William E. Miller, PE 13389 ENGINEERING
		CONSTRUCTION MANAGEMENT
		9125 N. Clydesdale Road PH (303) 908-0082 Castle Rock, Colorado 80108 FAX (303) 708-8399
		Boondocks Parker, Colorado
		Sediment & Erosion Control Plan Final Stage
		Construction Plans
		DATE 09/16/2014 DES/DF1/CHK. WEM/km PROJ. NO. 13-343 SHEET 9 OF 24

NO CHANGES ARE TO BE MADE TO THIS DRAWING WITHOUT WRITTEN PERMISSION OF THE TOWN OF PARKER.

- GRADING, DRILLING, CLEARING, EXCAVATING, BACK-FILLING, SOIL STRIPPING, SOIL IMPORTING EXPORTING OR ANY OTHER FORM OF SOIL DISTURBANCE SHALL NOT COMMENCE UNTIL A TOWN OF PARKER GRADING/EXCAVATION PERMIT HAS BEEN ISSUED.
- THE TOWN OF PARKER GRADING/EXCAVATION PERMIT IS VALID FOR A PERIOD OF 2 YEARS FROM THE DATE OF ISSUANCE. ANY LAPSE IN PERMIT COVERAGE MAY RESULT IN THE ISSUANCE OF A STOP WORK ORDER AND/OR FINES.
- ALL EROSION AND SEDIMENT CONTROL BMPs SHALL BE INSTALLED ACCORDING TO THE CBMP PLAN INSTALLATION NOTES AND DETAILS AND/OR PERMITTED VARIANCES. ALL MATERIALS, WORKMANSHIP AND INSTALLATION METHODS ARE SUBJECT TO INSPECTION BY THE TOWN'S INSPECTOR. THE TOWN OF PARKER RESERVES THE RIGHT TO ACCEPT OR REJECT ANY SUCH MATERIALS, WORKMANSHIP AND/OR INSTALLATION METHODS THAT DO NOT CONFORM TO THE CBMP PLAN AND/OR PERMITTED VARIANCES.
- THE EROSION CONTROL SUPERVISOR SHALL REVISE OR MODIFY THE EROSION AND SEDIMENT CONTROL MEASURES IF IT BECOMES APPARENT THAT THE ORIGINAL PLAN IS INADEQUATE, OR AS A RESULT OF DEFICIENCIES IDENTIFIED DURING INSPECTIONS PERFORMED BY THE TOWN'S INSPECTOR.
- THE INSTALLATION OF ADDITIONAL EROSION AND SEDIMENT CONTROL BEST MANAGEMENT PRACTICES (BMPs) MAY BE REQUIRED OF THE EROSION CONTROL SUPERVISOR, PROPERTY OWNER, SITE DEVELOPER, CONTRACTOR AND/OR THEIR AUTHORIZED AGENTS AT ANY TIME THROUGHOUT THE DURATION OF THE PROJECT CONSTRUCTION AND/OR SUBSEQUENT REVEGETATION PERIOD.
- THE EROSION CONTROL SUPERVISOR SHALL BE RESPONSIBLE FOR ENSURING THAT THE SITE REMAINS IN COMPLIANCE WITH THE NOTICE OF NUISANCE REPORTS (g.k.a. CONSTRUCTION SITE RUNOFF CONTROL INSPECTION REPORTS), APPROVED CBMP PLAN(S) AND THE TOWN OF PARKER STORM DRAINAGE AND ENVIRONMENTAL CRITERIA MANUAL.
- THE EROSION CONTROL SUPERVISOR SHALL BE READILY AVAILABLE TO DISCUSS AND CORRECT ANY PROBLEMS THAT MAY ARISE RELATING TO GRADING, EROSION AND SEDIMENT CONTROL.
- IF IT IS ANTICIPATED THAT ALL OR A PORTION OF THE PROJECT WILL OCCUR DURING SEASONS SUSCEPTIBLE TO SNOWFALL, THE USE OF CERTAIN EROSION AND SEDIMENT CONTROL BMPs ADJACENT TO PUBLIC ROADWAYS MAY NEED TO BE RECONSIDERED DUE TO THE NATURE OF SNOW REMOVAL OPERATIONS. AN APPROVED ALTERNATIVE MAY BE NECESSARY TO MINIMIZE DAMAGE FROM THESE OPERATIONS. THE TOWN OF PARKER ASSUMES NO RESPONSIBILITY FOR DAMAGE TO ANY BMPs AS A RESULT OF SNOW PLOWING AND SNOW REMOVAL.
- AREAS OF LAND DISTURBANCE EQUAL TO 40 ACRES OR GREATER SHALL NOT BE EXPOSED FOR MORE THAN 30 CONSECUTIVE DAYS WITHOUT TEMPORARY OR PERMANENT STABILIZATION.
- AUTHORIZED EXEMPTIONS MAY BE ALLOWED TO THE 40-ACRE LIMIT FOR REMOVAL AND STORAGE OF CUT MATERIAL WHERE (A) GEOTECHNICAL LIMITATIONS RESTRICT THE USE OF TEMPORARY OR PERMANENT STABILIZATION OF THE STORED MATERIAL (E.G., SWELLING SOILS, ROCK) AND (B) WHEN THE OWNER CAN DEMONSTRATE THAT THE 40-ACRE LIMIT IS PHYSICALLY AND/OR FINANCIALLY IMPRACTICABLE. FOR SITES GRANTED THIS EXEMPTION, A PHASING AND EARTHWORK QUANTITIES PLAN SHALL BE SUBMITTED TO THE PUBLIC WORKS DEPARTMENT AND APPROVED PRIOR TO THE COMMENCEMENT OF LAND DISTURBANCE ACTIVITIES. SUBMITTAL REQUIREMENTS INCLUDE:
 - PHASING PLAN SHOWING CUT AND FILL VOLUMES AND LOCATIONS FOR EACH PHASE AND PROJECT TOTALS.
 - EARTHWORK QUANTITY PLAN SHOWING CUT AND FILL VOLUMES AND LOCATIONS FOR EACH PHASE AND PROJECT TOTALS.
 - BMP PLAN SHOWING SPECIFIC EROSION AND SEDIMENT CONTROLS FOR EACH PHASE.

CBMP CONSTRUCTION BEST MANAGEMENT PRACTICES
 GEN NOTES 1 OF 4 Oct. 2013

NO CHANGES ARE TO BE MADE TO THIS DRAWING WITHOUT WRITTEN PERMISSION OF THE TOWN OF PARKER.

- ANY EROSION AND SEDIMENT CONTROL BMPs THAT ARE DAMAGED OR IN NEED OF MAINTENANCE OR REPLACEMENT SHALL BE CORRECTED AS SOON AS POSSIBLE, IMMEDIATELY IN MOST CASES.
- ALL DEFICIENCIES LISTED ON THE NOTICE OF NUISANCE FORM SHALL BE COMPLETED AS SOON AS POSSIBLE, IMMEDIATELY IN MOST CASES. ALL REQUIRED ACTIONS MUST BE IN THE CORRECTED FORM DURING THE FOLLOW-UP INSPECTION.
- THE EROSION CONTROL SUPERVISOR IS RESPONSIBLE FOR ENSURING THAT ALL STREETS, CURBS, GUTTERS, SIDEWALKS, DRIVEWAYS, PARKING LOTS, ALLEYS, TRICKLE CHANNELS, AND/OR OTHER IMPERVIOUS SURFACES IMPACTED BY CONSTRUCTION ACTIVITIES ARE THOROUGHLY CLEANED THROUGHOUT THE DAY IF THEY BECOME SOILED. THESE AREAS MUST ALSO BE THOROUGHLY CLEAN BEFORE THE END OF THE WORK DAY.
- BULK STORAGE STRUCTURES FOR PETROLEUM PRODUCTS AND OTHER CHEMICALS SHALL HAVE ADEQUATE PROTECTION SO AS TO CONTAIN ALL SPILLS AND PREVENT ANY SPILLED MATERIAL FROM ENTERING STATE WATERS.
- ALL TRASH RECEPTACLES ON SITE SHALL BE FREE OF HOLES, CRACKS, GAPS, AND/OR OTHER PERMEABLE AREAS THAT MAY ALLOW FOR THE DISCHARGE OF POLLUTANTS.
- ALL TRASH RECEPTACLES ON SITE SHALL BE EMPTIED AT A FREQUENCY AS TO ENSURE THAT THE TRASH REMAINS CONFINED TO THE RECEPTACLE.
- ALL LOOSE TRASH AND LITTER ASSOCIATED WITH THE PROJECT MUST BE REMOVED AND PROPERLY DISCARDED ON A DAILY BASIS.
- ALL PORTABLE TOILETS SHALL BE STAKED DOWN AT ALL TIMES USING U-SHAPED REBAR STAKES. THE PORTABLE TOILETS SHALL ALSO BE PLACED A MINIMUM DISTANCE OF 10 FEET FROM ALL IMPERVIOUS SURFACES, INCLUDING, BUT NOT LIMITED TO STREETS CURBS, GUTTERS, SIDEWALKS AND PARKING LOTS.
- THE EROSION CONTROL SUPERVISOR SHALL MAINTAIN STRICT ADHERENCE TO THE LIMITS OF CONSTRUCTION AND PROPERTY LIMITS FOR ALL MATERIALS, VEHICLES AND EQUIPMENT. FAILURE TO ABIDE BY THIS REQUIREMENT MAY RESULT IN THE ISSUANCE OF A STOP WORK ORDER.
- ALL CONSTRUCTION TRAFFIC MUST ENTER AND EXIT THE SITE THROUGH THE APPROVED ACCESS POINT(S). A VEHICLE TRACKING CONTROL PAD IS REQUIRED AT ALL APPROVED ACCESS POINTS TO THE SITE. EXCEPTIONS MAY BE CONSIDERED FOR CONSTRUCTION ACTIVITY OCCURRING IMMEDIATELY ADJACENT TO PAVED AREAS AND WHERE ALTERNATIVE BMPs ARE IMPLEMENTED. SUCH ACTIVITY MAY INCLUDE, BUT NOT BE LIMITED TO RESIDENTIAL CONSTRUCTION, UTILITY CONSTRUCTION, ETC.
- NO PERMANENT SLOPES GREATER THAN 3:1 ARE ALLOWED.
- ALL PERMANENT SLOPES STEEPER THAN 4:1 (HORIZONTAL TO VERTICAL) SHALL REQUIRE EROSION CONTROL BLANKET(S), TEMPORARY SLOPES IN TEMPORARY SEDIMENT BASINS THAT ARE STEEPER THAN 4:1 MAY REQUIRE EROSION CONTROL BLANKETS.
- THE EROSION CONTROL SUPERVISOR SHALL BE RESPONSIBLE FOR CORRECTING ANY ADVERSE IMPACTS THAT OCCUR TO NEIGHBORING PROPERTIES. THE EROSION CONTROL SUPERVISOR MUST OBTAIN PERMISSION FROM LAND OWNERS PRIOR TO ENTERING SUCH PROPERTY.
- A WATER SOURCE SHALL BE AVAILABLE ONSITE DURING CONSTRUCTION ACTIVITIES, AND UTILIZED TO MINIMIZE FUGITIVE DUST. ALTERNATIVE BMPs MAY BE REQUIRED IF INITIAL ATTEMPTS TO SUPPRESS DUST ARE UNSUCCESSFUL.

CBMP CONSTRUCTION BEST MANAGEMENT PRACTICES
 GEN NOTES 2 OF 4 Oct. 2013

NO CHANGES ARE TO BE MADE TO THIS DRAWING WITHOUT WRITTEN PERMISSION OF THE TOWN OF PARKER.

- ALL CHEMICAL OR HAZARDOUS MATERIAL SPILLS, INCLUDING CONCRETE WASHOUT WATER, WHICH MAY ENTER WATERS OF THE STATE OF COLORADO, WHICH INCLUDES BUT ARE NOT LIMITED TO, SURFACE WATER, GROUND WATER, DRY GULLIES OR STORM SEWERS LEADING TO SURFACE WATER, SHALL BE IMMEDIATELY REPORTED TO THE COLORADO DEPARTMENT OF PUBLIC HEALTH AND ENVIRONMENT (CDPHE) PER 25-B-601, AND THE TOWN OF PARKER. RELEASES OF PETROLEUM PRODUCTS AND CERTAIN HAZARDOUS SUBSTANCES LISTED UNDER THE FEDERAL CLEAN WATER ACT (40 CFR PART 116) MUST BE REPORTED TO THE NATIONAL RESPONSE CENTER AND THE CDPHE. SPILLS THAT POSE AN IMMEDIATE SAFETY HAZARD SHALL BE REPORTED TO 911.
- THE CLEANING OF CONCRETE TRUCKS AND EQUIPMENT IS RESTRICTED TO THE APPROVED CONCRETE WASHOUT LOCATION ON THE JOB SITE. CONCRETE WASH WATER SHALL NOT BE DISCHARGED TO STATE WATERS OR STORM SEWER SYSTEMS.
- VEHICLE AND EQUIPMENT DEGREASING IS PROHIBITED ON THE JOB SITE.
- ALL DEWATERING ON SITE SHALL BE COORDINATED WITH THE TOWN'S INSPECTOR. A STATE PERMIT MAY BE REQUIRED FOR DEWATERING. THE EROSION CONTROL SUPERVISOR IS RESPONSIBLE FOR OBTAINING AND ADHERING TO ALL APPLICABLE PERMITS.
- HYDRAULIC SEEDING AND/OR HYDRAULIC MULCHING ARE ONLY ALLOWED IN AREAS UNDER TEMPORARY OR PERMANENT IRRIGATION OR FOR THE PURPOSE OF TEMPORARY SOIL STABILIZATION.
- APPLICABLE CONSTRUCTION BMPs SHALL REMAIN IN PLACE AND PROPERLY MAINTAINED UNTIL ALL LANDSCAPING HAS BEEN INSTALLED AND THE DESIRABLE VEGETATION HAS REACHED A POINT IN WHICH EROSION AND SEDIMENTATION IS NO LONGER A CONCERN AS DETERMINED BY THE TOWN'S INSPECTOR.
- GRADING SECURITY RELEASE REQUIREMENTS:
 - DEVELOPABLE PROPERTY: IN ORDER FOR THE GRADING SECURITY TO BE RELEASED, THE SITE MUST MEET ITEMS A-H OR ITEM I (BELOW).
 - ALL SOIL-DISTURBING ACTIVITIES ASSOCIATED WITH THE GRADING PERMIT HAVE PERMANENTLY CEASED.
 - UNIFORM PERENNIAL VEGETATION COVER HAS BEEN ESTABLISHED WITH AN INDIVIDUAL PLANT DENSITY OF AT LEAST SEVENTY PERCENT (70%) OF PRE-DISTURBANCE LEVELS.
 - ALL CBMPs HAVE BEEN PROPERLY REMOVED FROM THE SITE.
 - IF ANY EROSION IS PRESENT, IT IS INSIGNIFICANT AND IS NOT LEAVING THE SITE AND/OR LEADING INTO ANY ON-SITE DRAINAGE INFRASTRUCTURE THAT MAY CONVEY SURFACE WATER OFF SITE.
 - WEEDS REPRESENT NO MORE THAN FIFTY PERCENT (50%) OF THE TOTAL VEGETATION ON THE SITE.
 - NO WEEDS ARE PRESENT FROM LIST A OF THE COLORADO NOXIOUS WEED LIST, AS AMENDED.
 - THE SITE IS PREDOMINANTLY FREE OF WEEDS FROM LIST B OF THE COLORADO NOXIOUS WEED LIST, AS AMENDED.
 - WEEDS ARE EVENLY DISTRIBUTED THROUGHOUT THE SITE WITH NO LARGE CONCENTRATIONS PRESENT.
 - A NEW GRADING PERMIT AND REPLACEMENT SECURITY HAS BEEN SUBMITTED AND APPROVED FOR THE APPLICABLE SITE OR ASSIGNMENT AS PROVIDED BY SECTION 11.10.150 OF THE TOWN OF PARKER MUNICIPAL CODE. IT IS THE PROPERTY OWNER'S OBLIGATION AT THE TIME OF CLOSING TO ENSURE THAT THE NEW SITE OWNER HAS PROVIDED THE TOWN WITH A REPLACEMENT SECURITY.

CBMP CONSTRUCTION BEST MANAGEMENT PRACTICES
 GEN NOTES 3 OF 4 Oct. 2013

NO CHANGES ARE TO BE MADE TO THIS DRAWING WITHOUT WRITTEN PERMISSION OF THE TOWN OF PARKER.

- NONDEVELOPABLE PROPERTY: IN ORDER FOR THE GRADING SECURITY TO BE RELEASED, THE SITE MUST MEET ITEMS A-H AND J, OR ITEMS I AND J (BELOW).
 - ALL SOIL-DISTURBING ACTIVITIES ASSOCIATED WITH THE GRADING PERMIT HAVE PERMANENTLY CEASED.
 - ALL CBMPs HAVE BEEN PROPERLY REMOVED FROM THE SITE.
 - EROSION IS NEGLIGIBLE, IF EVEN PRESENT.
 - THE VEGETATION REPRESENTS A PERENNIAL STAND OF A DENSE, UNIFORM SURFACE OF GRASS WITH NO AREA GREATER THAN ONE (1) SQUARE FOOT THAT IS BARREN OF DESIRABLE VEGETATION, INFREQUENT, WIDELY SCATTERED AREAS WHERE NATIVE VEGETATION HAS NOT YET TAKEN HOLD MAY QUALIFY FOR ACCEPTANCE AT THE DISCRETION OF THE TOWN.
 - WEEDS REPRESENT NO MORE THAN TEN PERCENT (10%) OF THE TOTAL VEGETATION ON THE SITE.
 - NO WEEDS ARE PRESENT FROM LIST A OF THE COLORADO NOXIOUS WEED LIST, AS AMENDED.
 - THE SITE IS PREDOMINANTLY FREE OF WEEDS FROM LIST B OF THE COLORADO NOXIOUS WEED LIST, AS AMENDED.
 - WEEDS ARE EVENLY DISTRIBUTED THROUGHOUT THE SITE WITH NO LARGE CONCENTRATIONS PRESENT.
 - A NEW GRADING PERMIT AND REPLACEMENT SECURITY HAS BEEN SUBMITTED AND APPROVED FOR THE APPLICABLE SITE OR THE GRADING PERMIT HAS BEEN ASSIGNED AS PROVIDED BY SECTION 11.10.150 OF THE TOWN OF PARKER MUNICIPAL CODE. IT IS THE PROPERTY OWNER'S OBLIGATION AT THE TIME OF CLOSING ON THE SALE OF A SITE THAT IS SUBJECT TO A GRADING PERMIT, TO ENSURE THAT THE NEW PROPERTY OWNER HAS PROVIDED THE TOWN WITH A REPLACEMENT SECURITY.
 - ALL KNOWN DRAINAGE ISSUES ASSOCIATED WITH THE PROJECT HAVE BEEN MITIGATED AND A SUFFICIENT AMOUNT OF TIME HAS PASSED TO ENSURE THAT SUCH ISSUES HAVE BEEN CORRECTED. THIS REQUIREMENT DOES NOT INCLUDE THOSE DRAINAGE ISSUES ORIGINATING ON RESIDENTIAL LOTS.
 - NOXIOUS WEEDS MUST BE CONTROLLED AS PROVIDED UNDER STATE LAW AND SECTION 6.01.260 OF THE TOWN OF PARKER MUNICIPAL CODE. FAILURE TO CONTROL NOXIOUS WEEDS ON THE SITE MAY CONSTITUTE A NUISANCE, SUBJECT TO THE PENALTIES CONTAINED IN THE CODE.
- DEFINITIONS:

DEVELOPABLE PROPERTY MEANS ANY LAND THAT HAS BEEN GRADED AND IS PART OF A PLATTED LOT OR PLATTED TRACT OF RECORD, THAT WAS PLATTED FOR FUTURE DEVELOPMENT, INCLUDING RESIDENTIAL HOME CONSTRUCTION OR PUBLIC IMPROVEMENTS.

NONDEVELOPABLE PROPERTY MEANS LAND THAT HAS BEEN GRADED AND WILL NOT BE FURTHER DISTURBED AS PART OF ANY FUTURE DEVELOPMENT. EXAMPLES INCLUDE, BUT ARE NOT LIMITED TO: PARKS, OPEN SPACE, HOMEOWNER ASSOCIATION OR BUSINESS ASSOCIATION PLATTED TRACTS, DETENTION PONDS AND DRAINAGEWAYS.
- FAILURE TO COMPLY WITH ANY OF THE REQUIREMENTS DESCRIBED IN THIS SECTION MAY RESULT IN THE ISSUANCE OF: A NOTICE OF INTENT TO ISSUE A STOP WORK ORDER, A STOP WORK ORDER AND/OR THE REMEDIES/PENALTIES DESCRIBED IN CHAPTER 11.10 OF THE TOWN OF PARKER MUNICIPAL CODE.
- ANY PERSON CONVICTED OF VIOLATING ANY PROVISION OF THE TOWN OF PARKER GRADING AND EARTH MOVEMENT SECTION OF THE MUNICIPAL CODE SHALL BE GUILTY OF A MISDEMEANOR AND, UPON CONVICTION, BE PUNISHED BY A FINE OF NOT MORE THAN FOUR HUNDRED NINETY NINE DOLLARS (\$499.00) FOR EACH SEPARATE OFFENSE, EACH DAY A VIOLATION CONTINUES SHALL CONSTITUTE A SEPARATE OFFENSE. THE TOWN ALSO MAY SEEK IN MUNICIPAL COURT AN INJUNCTION, ABATEMENT, RESTITUTION OR ANY OTHER REMEDY TO PREVENT, ENJOIN, ABATE OR REMOVE THE VIOLATION. A PERSON CONVICTED OF VIOLATING CHAPTER 11.10 OF THE TOWN OF PARKER MUNICIPAL CODE SHALL BE LIABLE FOR THE ACTUAL COST OF REHABILITATING THE PROPERTY. THE COSTS MAY BE RECOVERED AS RESTITUTION IN MUNICIPAL COURT PROCEEDINGS OR IN A SEPARATE CIVIL ACTION.
- THE TOWN OF PARKER RESERVES THE RIGHT TO ALLOW MODIFICATIONS AND SUBSTITUTIONS TO THE CBMP NOTES AND DETAILS WHEN SUCH MODIFICATIONS AND SUBSTITUTIONS OFFER THE SAME LEVEL OF PROTECTION AS THE STANDARD REQUIREMENTS BASED UPON THE SPECIFIC SITUATION, AS DETERMINED BY TOWN STAFF. DUE TO THE INSIGNIFICANCE AND REGULARITY OF SUCH MODIFICATIONS AND SUBSTITUTIONS, THE APPROVAL OF SUCH VARIATIONS MAY NOT BE DOCUMENTED BY TOWN STAFF.

CBMP CONSTRUCTION BEST MANAGEMENT PRACTICES
 GEN NOTES 4 OF 4 Oct. 2013

NO CHANGES ARE TO BE MADE TO THIS DRAWING WITHOUT WRITTEN PERMISSION OF THE TOWN OF PARKER.

- | | | |
|--|-------|--|
| | CD | CHECK DAM |
| | CF | CONSTRUCTION FENCE |
| | CP | CULVERT PROTECTION |
| | CWA | CONCRETE WASHOUT AREA |
| | D | DEWATERING |
| | DD | DIVERSION DITCH |
| | DP | DETENTION POND PROTECTION |
| | DTC | DEBRIS TRASH CONTROL |
| | ECB | EROSION CONTROL BLANKET |
| | IPAN | INLET PROTECTION FOR AREA INLETS NOT IN PAVEMENT |
| | IPAP | INLET PROTECTION FOR AREA INLETS IN PAVEMENT |
| | IPCOG | INLET PROTECTION, CURB ON-GRADE, TYPE R INLET |
| | IPCOS | INLET PROTECTION, CURB ON SUMP, TYPE R INLET |

CBMP CONSTRUCTION BEST MANAGEMENT PRACTICES
 LEGEND 1 OF 3 Oct. 2013

NO CHANGES ARE TO BE MADE TO THIS DRAWING WITHOUT WRITTEN PERMISSION OF THE TOWN OF PARKER.

- | | | |
|--|------|--------------------------------|
| | LP | LOT PROTECTION |
| | MWP | MASONRY WORK PROTECTION |
| | PTP | PORTABLE TOILET PROTECTION |
| | RCSC | ROUGH CUT STREET CONTROL |
| | RS | ROCK SOCK |
| | RSS | ROCK SOCK IN SWALE |
| | SB | STRAW BALE |
| | SCL | SEDIMENT CONTROL LOGS |
| | SF | SILT FENCE |
| | SMC | SEEDING, MULCHING AND CRIMPING |
| | SR | SURFACE ROUGHING |
| | SSA | STABILIZED STAGING AREA |
| | STP | SIDEWALK TRANSITION PROTECTION |

CBMP CONSTRUCTION BEST MANAGEMENT PRACTICES
 LEGEND 2 OF 3 Oct. 2013

NO CHANGES ARE TO BE MADE TO THIS DRAWING WITHOUT WRITTEN PERMISSION OF THE TOWN OF PARKER.

- | | | |
|--|-----|--------------------------|
| | TI | TEMPORARY IRRIGATION |
| | TSB | TEMPORARY SEDIMENT BASIN |
| | VTC | VEHICLE TRACKING CONTROL |

CBMP CONSTRUCTION BEST MANAGEMENT PRACTICES
 LEGEND 3 OF 3 Oct. 2013

REVISION	DATE	MM&D ENGINEERING SERVICES, INC. William E. Miller, PE 13389 ENGINEERING CONSTRUCTION MANAGEMENT 9125 N. Clydesdale Road PH (303) 908-0082 Castle Rock, Colorado 80108 FAX (303) 708-8399
PARKING LOT	09/24/2014	
COMMENTS	05/26/2015	
		Boondocks Parker, Colorado Sediment & Erosion Control Plan Notes & Details Construction Plans
		DATE 09/16/2014 DES/DFI/CHK. WEM/km PROJ. NO. 13-343 SHEET 10 OF 24

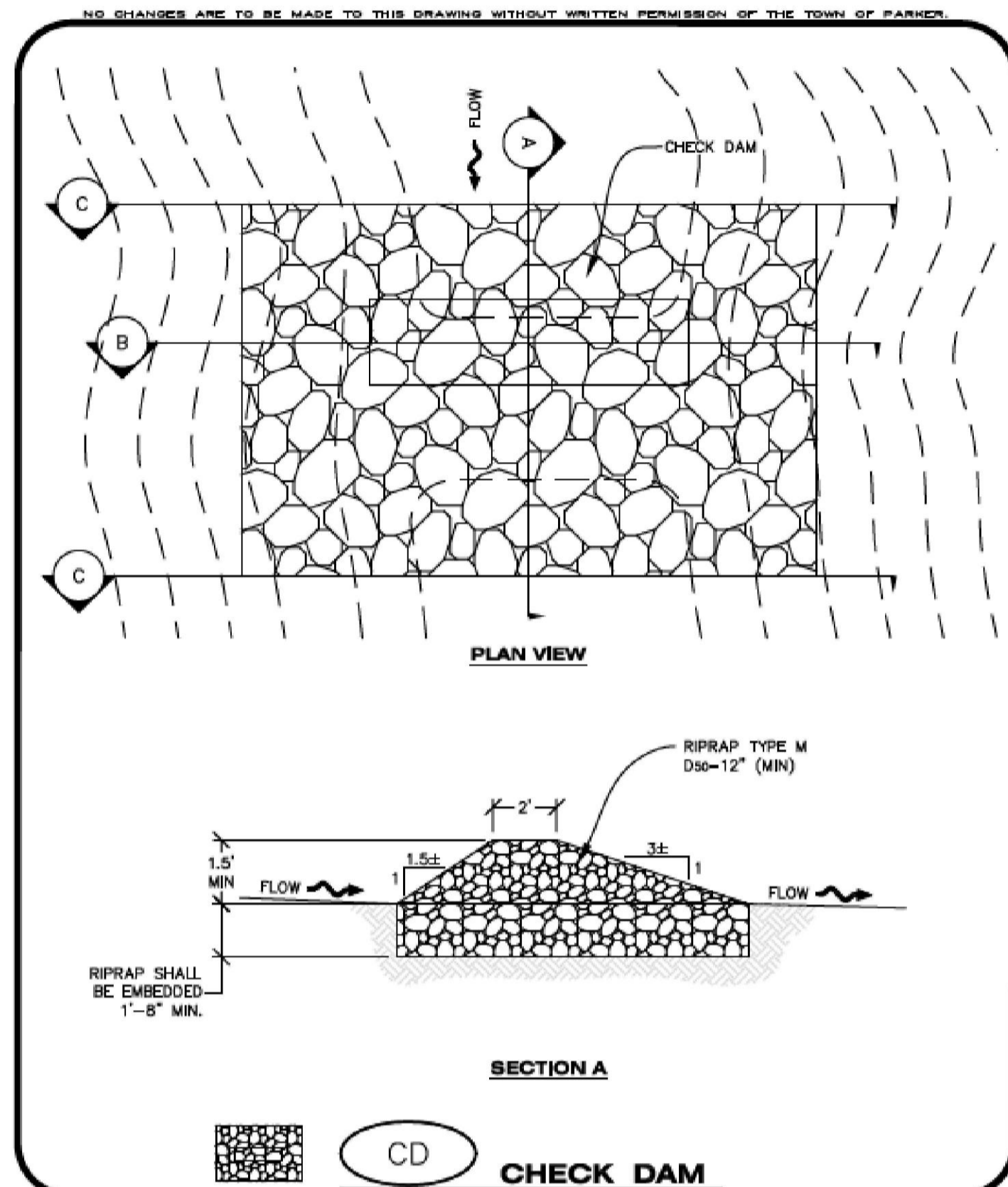

CBMP | **CD**
 CONSTRUCTION BEST MANAGEMENT PRACTICES | 1 OF 3
 Oct. 2013

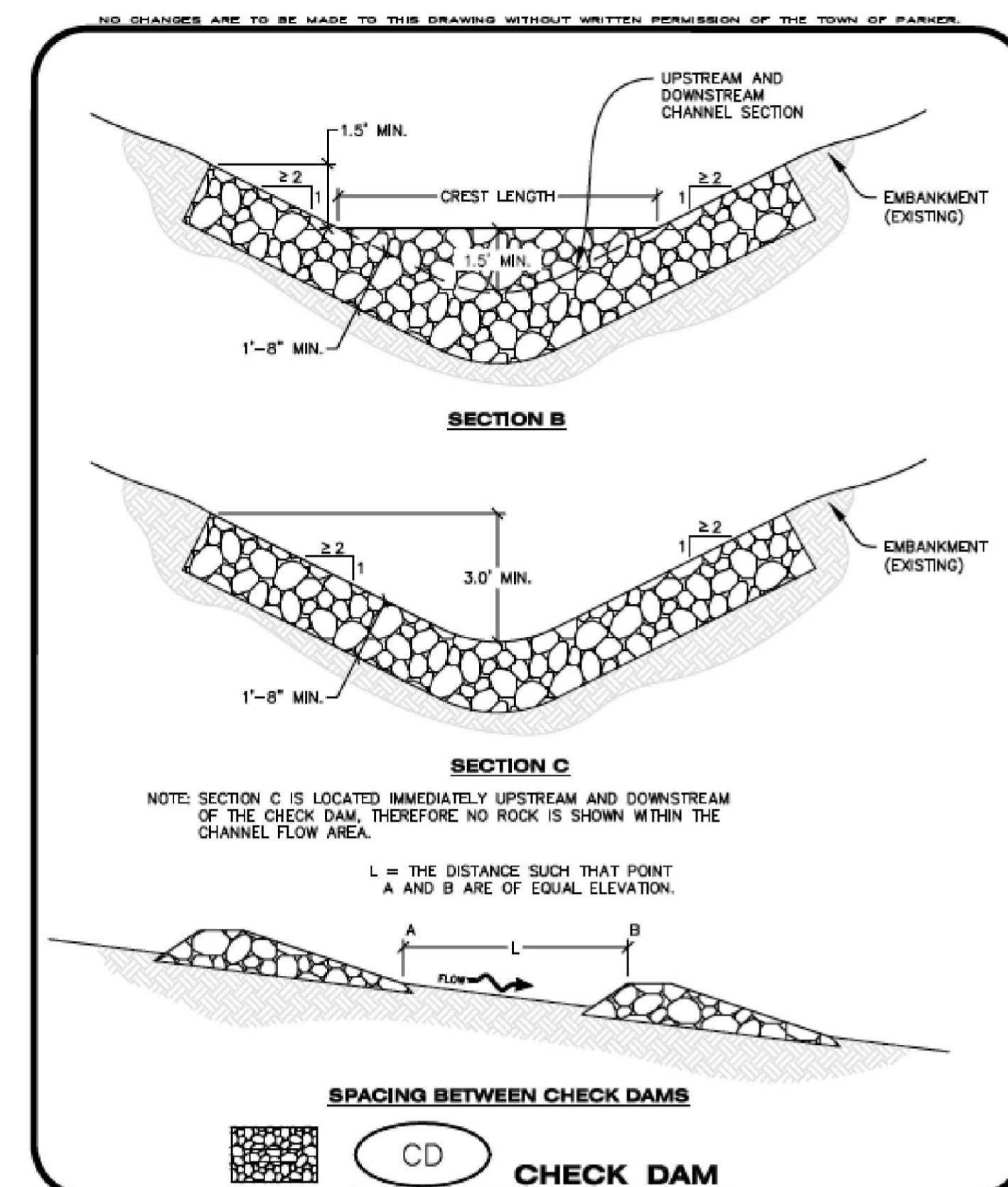

CBMP | **CD**
 CONSTRUCTION BEST MANAGEMENT PRACTICES | 2 OF 3
 Oct. 2013

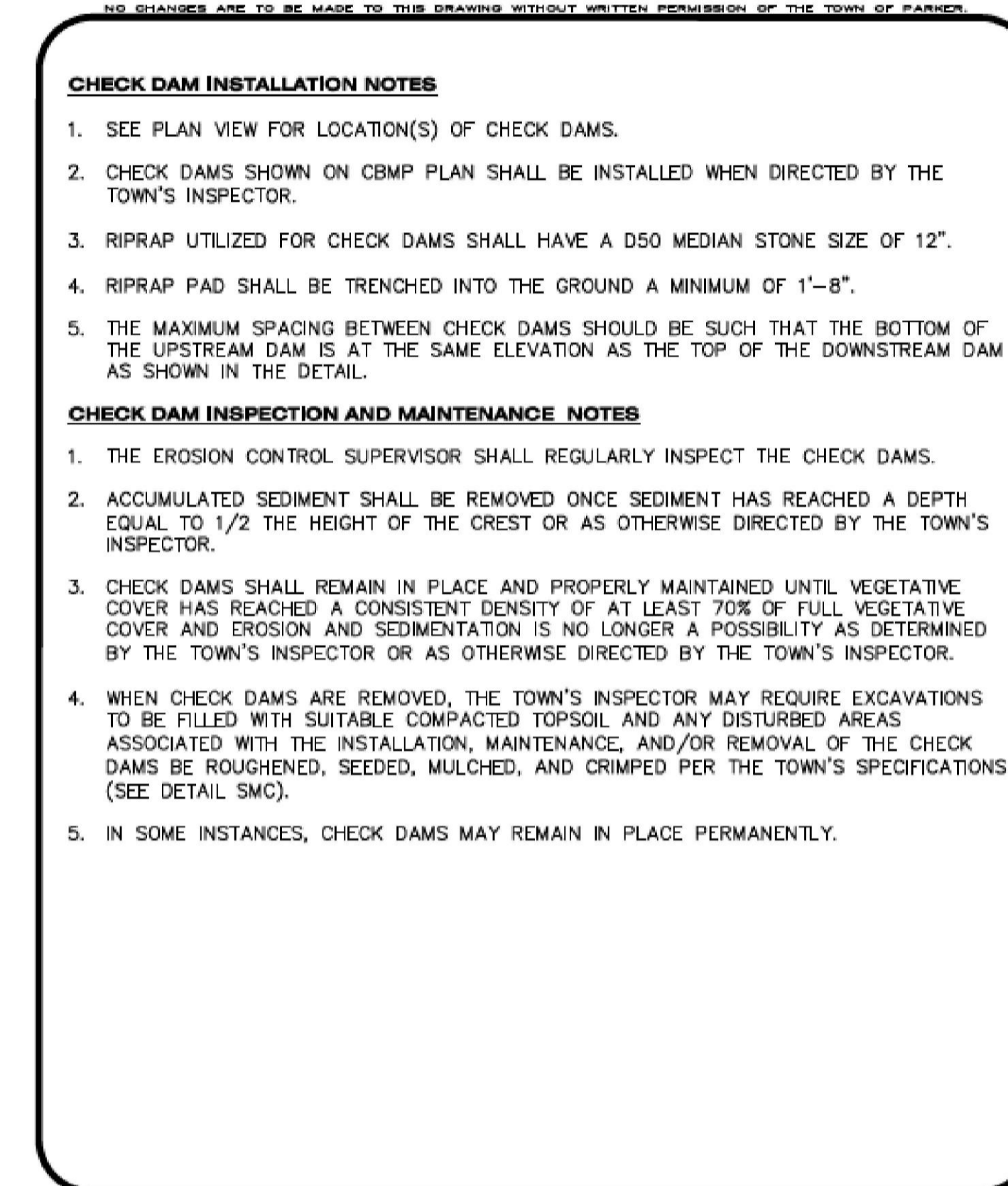

CBMP | **CD**
 CONSTRUCTION BEST MANAGEMENT PRACTICES | 3 OF 3
 Oct. 2013

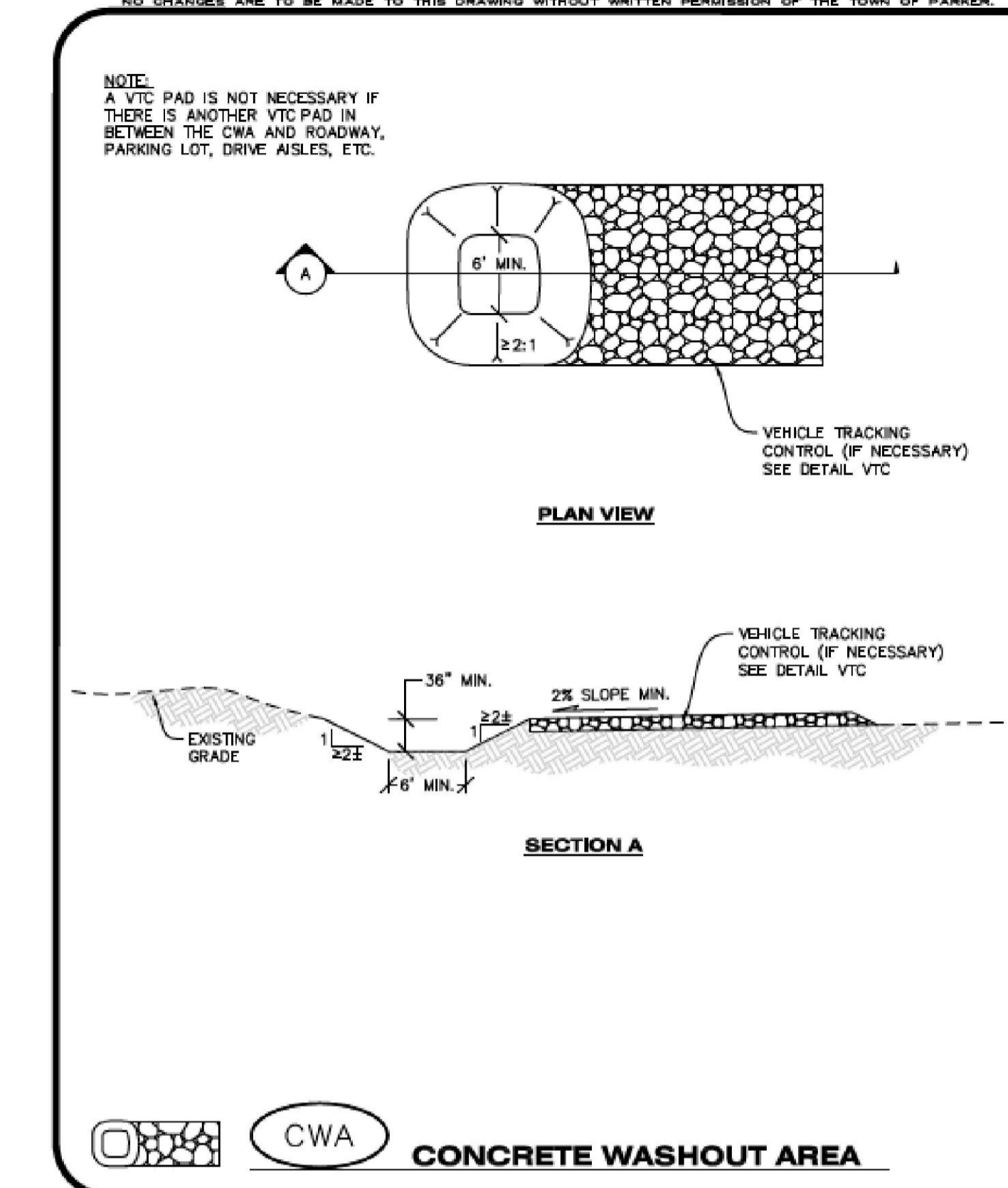

CBMP | **CWA**
 CONSTRUCTION BEST MANAGEMENT PRACTICES | 1 OF 2
 Oct. 2013

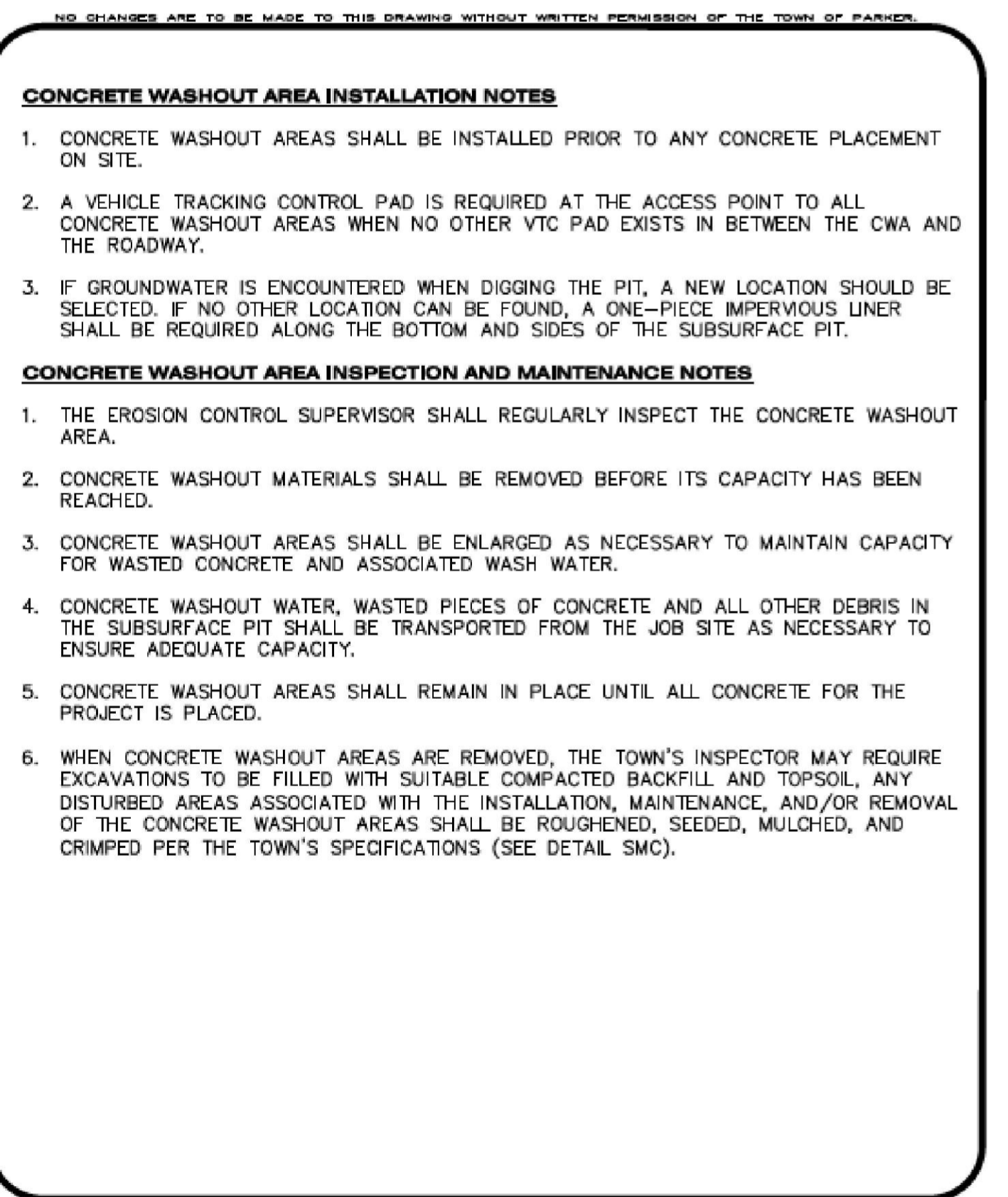

CBMP | **CWA**
 CONSTRUCTION BEST MANAGEMENT PRACTICES | 2 OF 2
 Oct. 2013

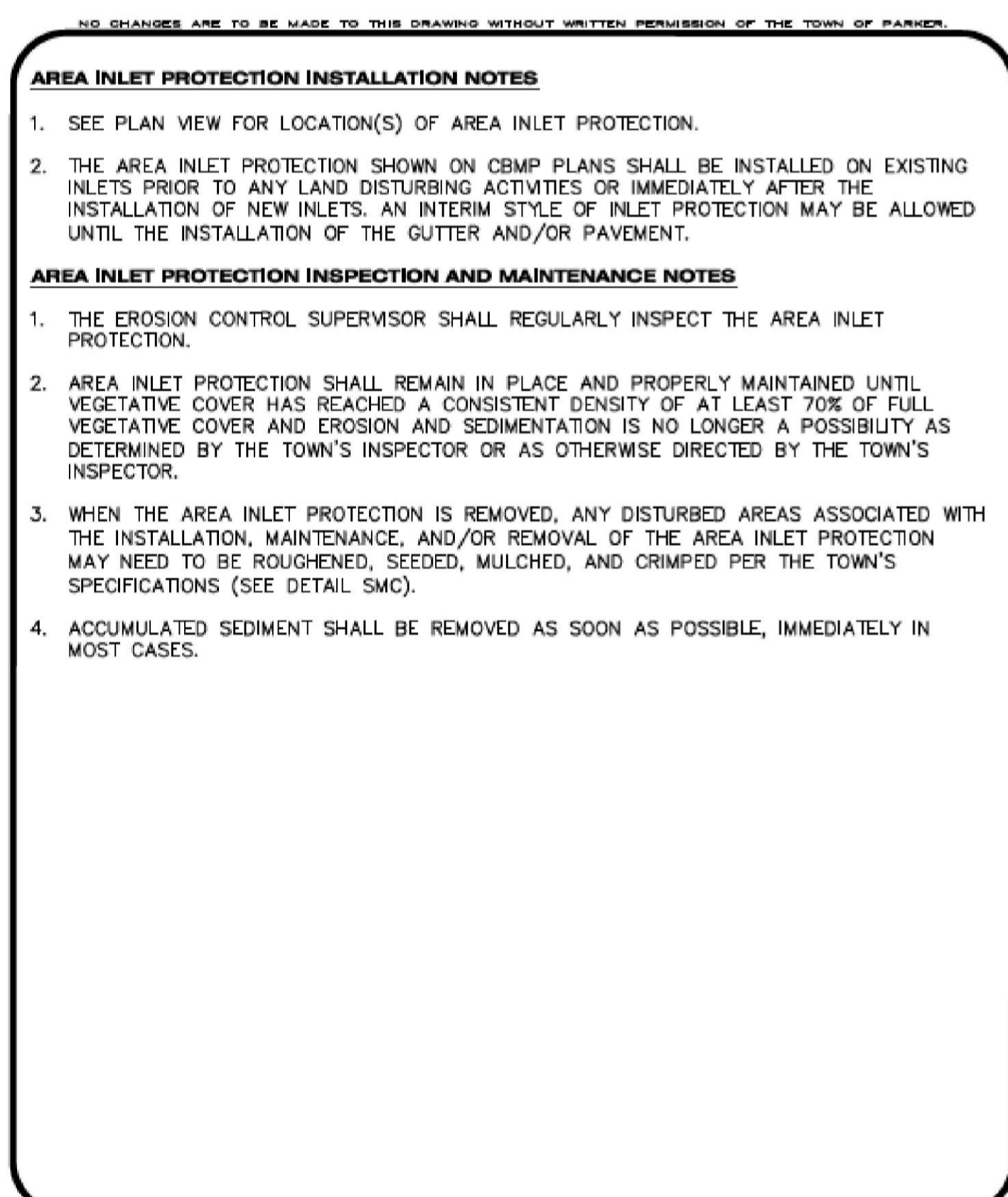

CBMP | **IPAN**
 CONSTRUCTION BEST MANAGEMENT PRACTICES | 1 OF 1
 Oct. 2013

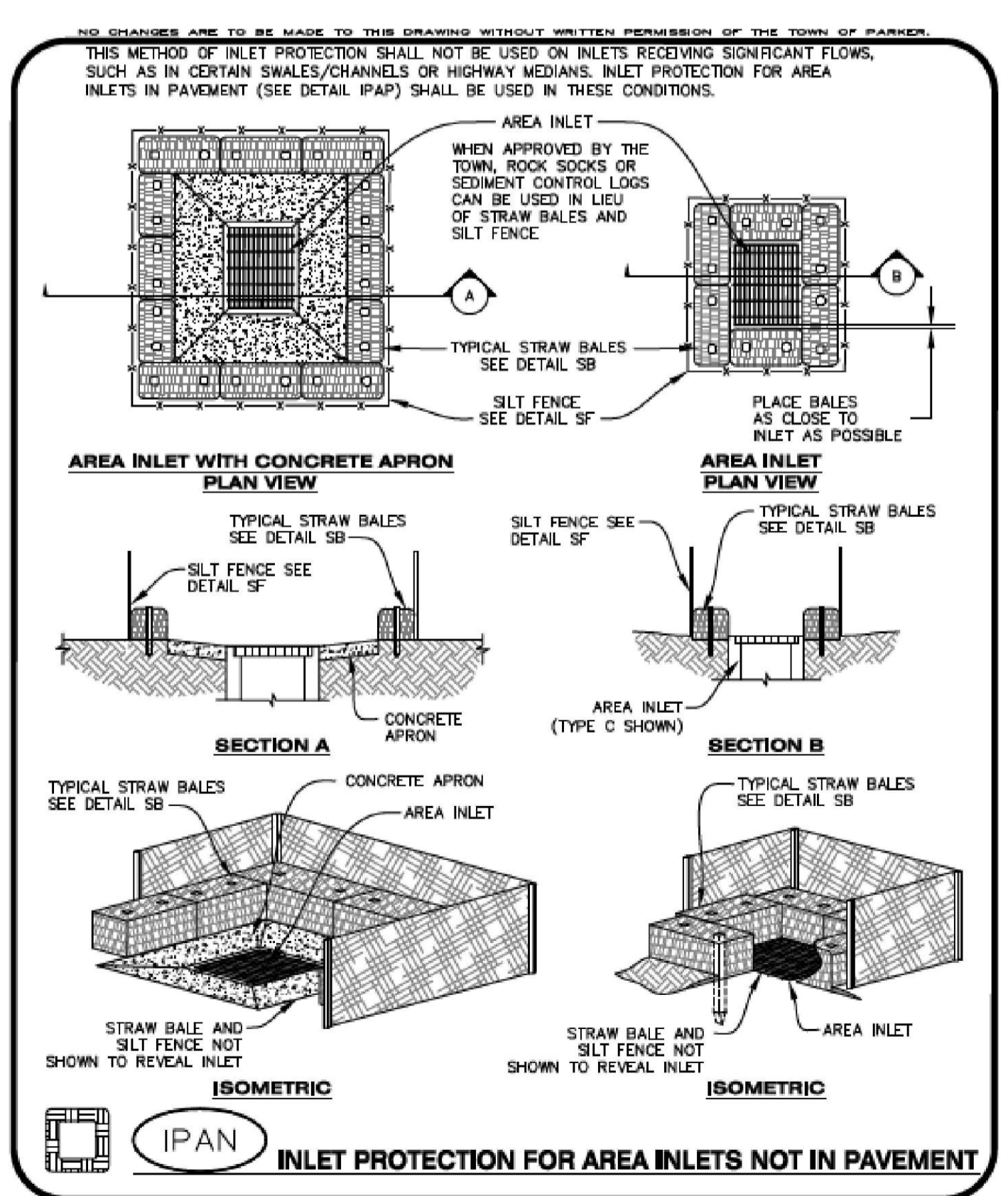

CBMP | **IPAN**
 CONSTRUCTION BEST MANAGEMENT PRACTICES | 1 OF 1
 Oct. 2013

REVISION	DATE	MM&D ENGINEERING SERVICES, INC. William E. Miller, PE 13389 ENGINEERING CONSTRUCTION MANAGEMENT 9125 N. Clydesdale Road PH (303) 908-0082 Castle Rock, Colorado 80108 FAX (303) 708-8399
PARKING LOT	09/24/2014	
COMMENTS	05/26/2015	
		Boondocks Parker, Colorado Sediment & Erosion Control Plan Notes & Details Construction Plans
		DATE 09/16/2014 DES/DFI/GHK WEM/km PROJ. NO. 13-343 SHEET 11 OF 24

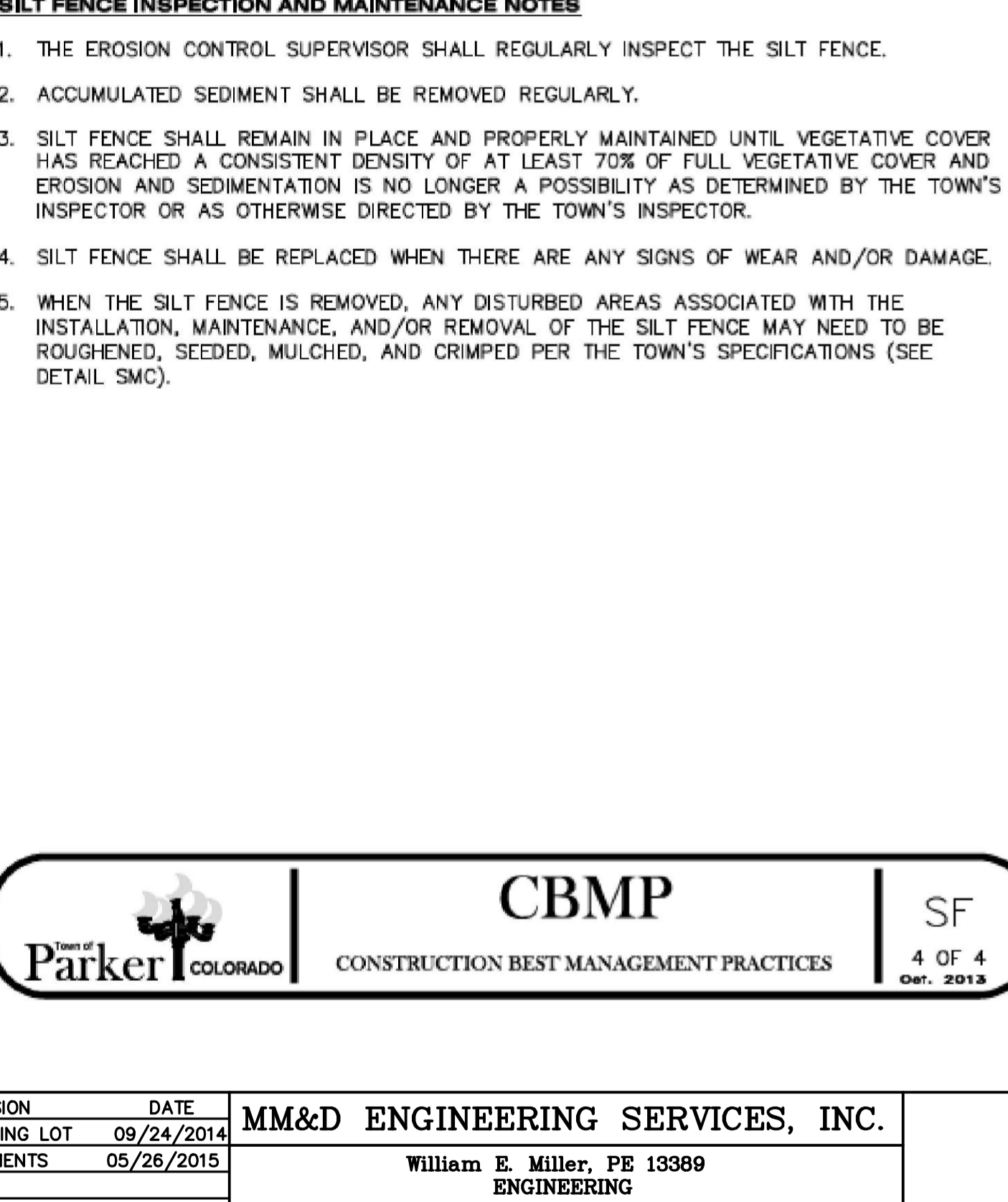
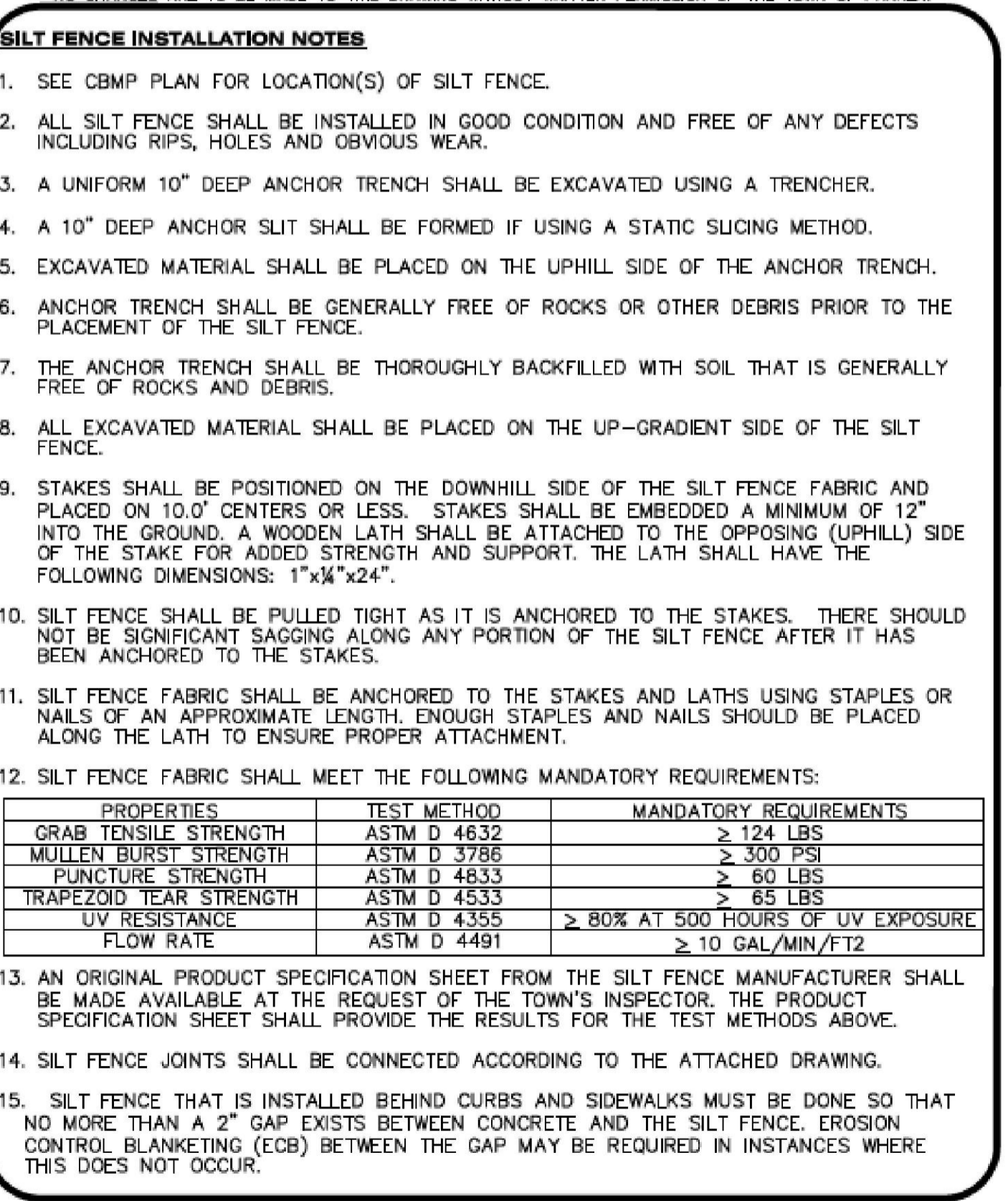
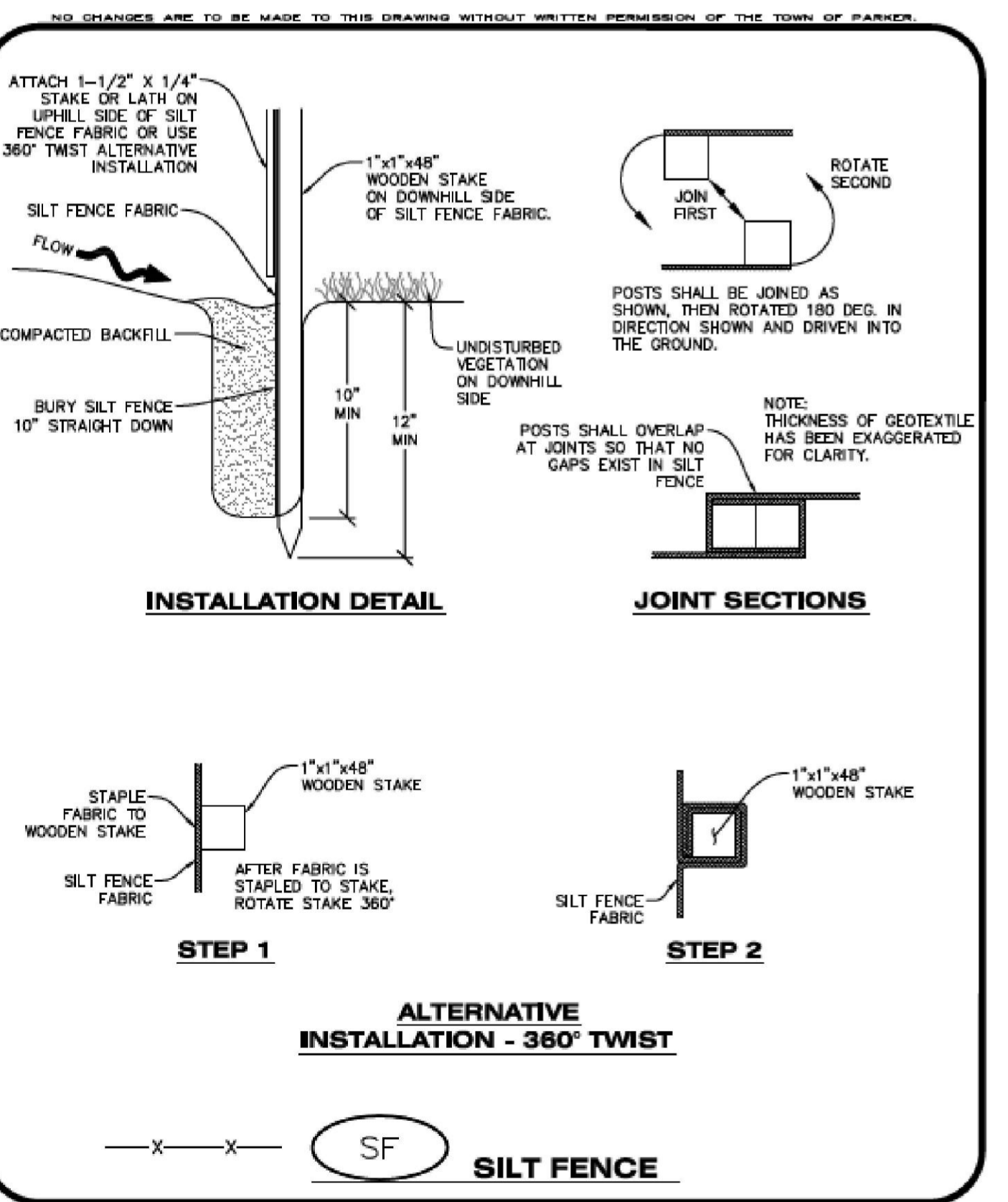
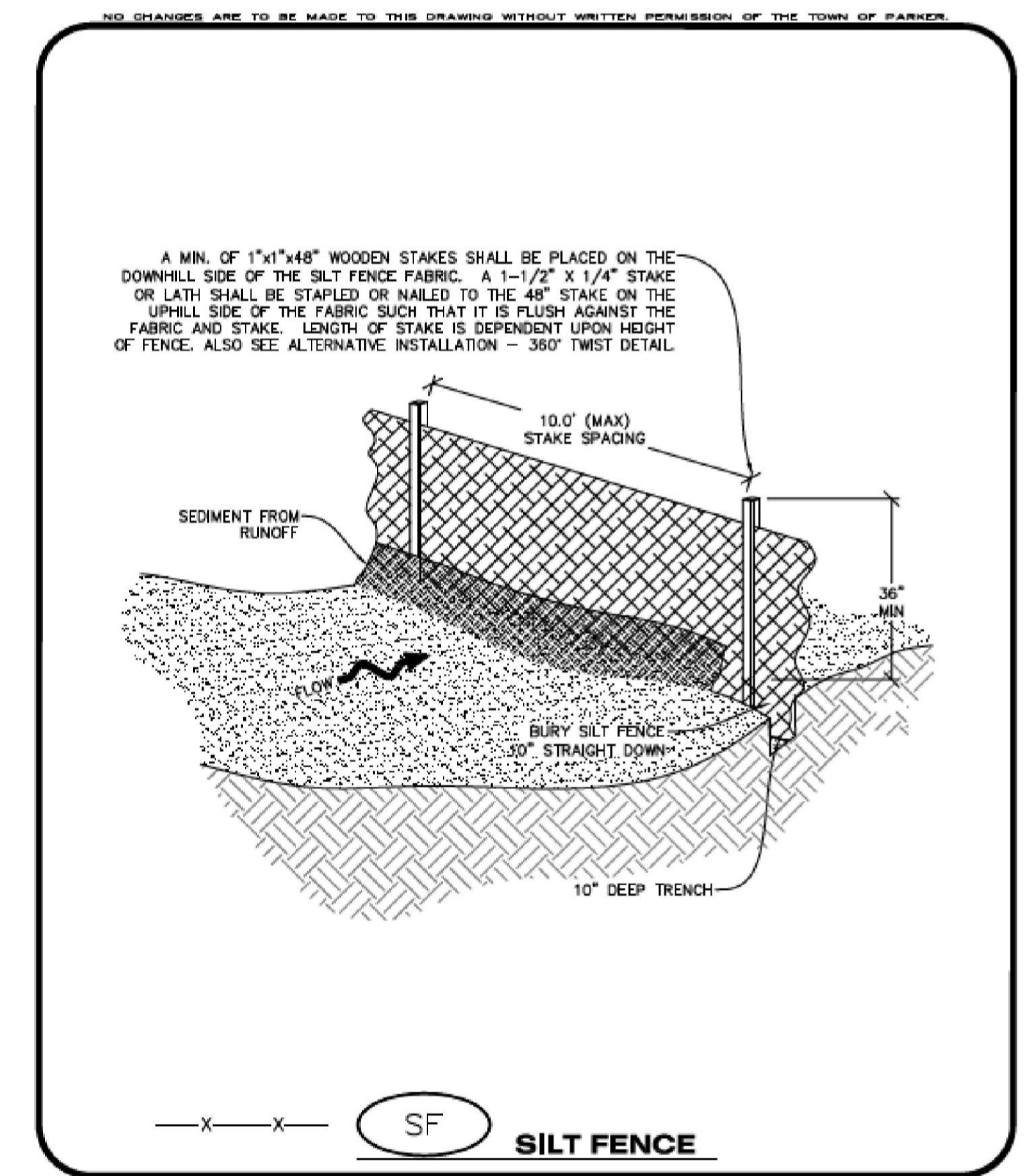
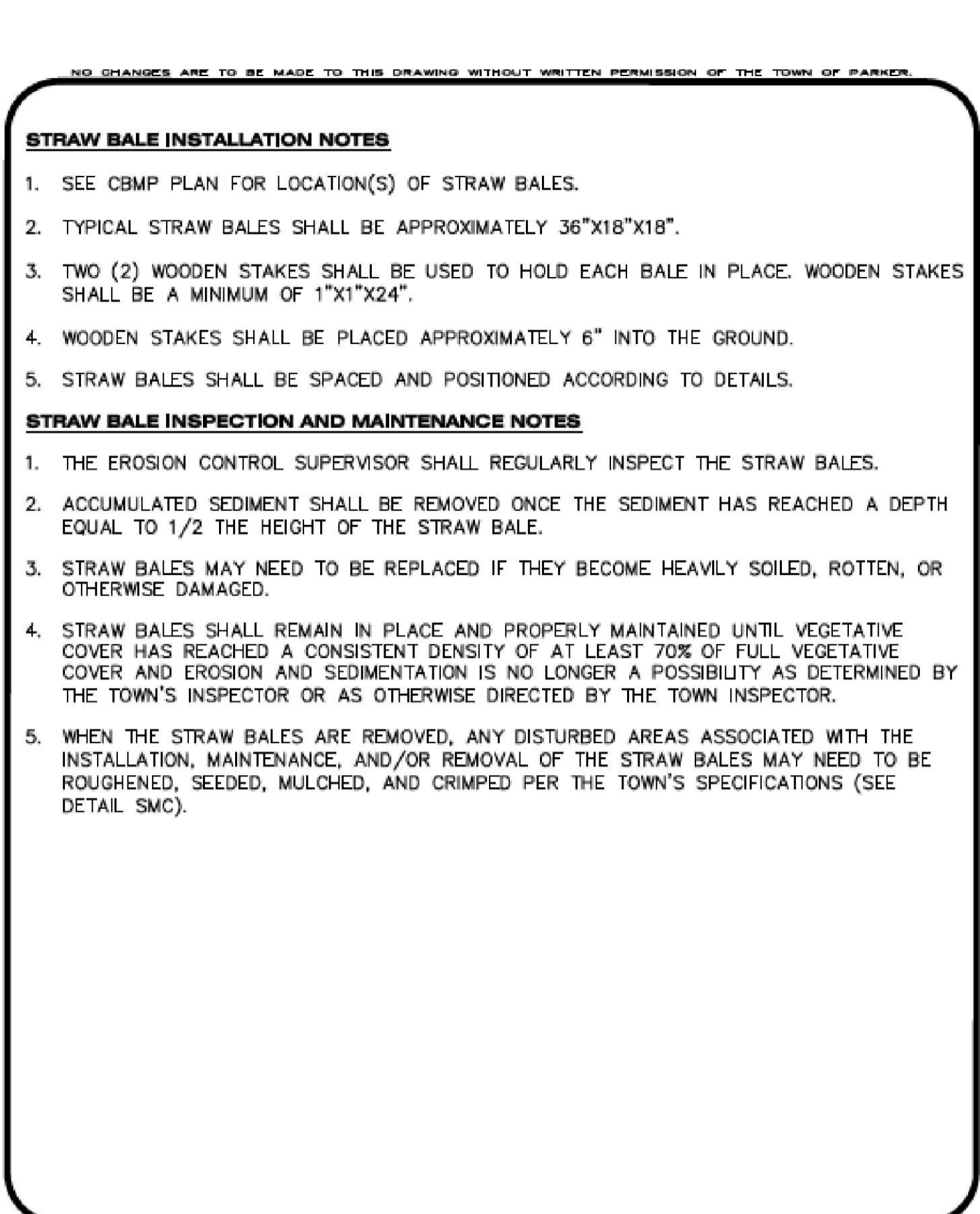
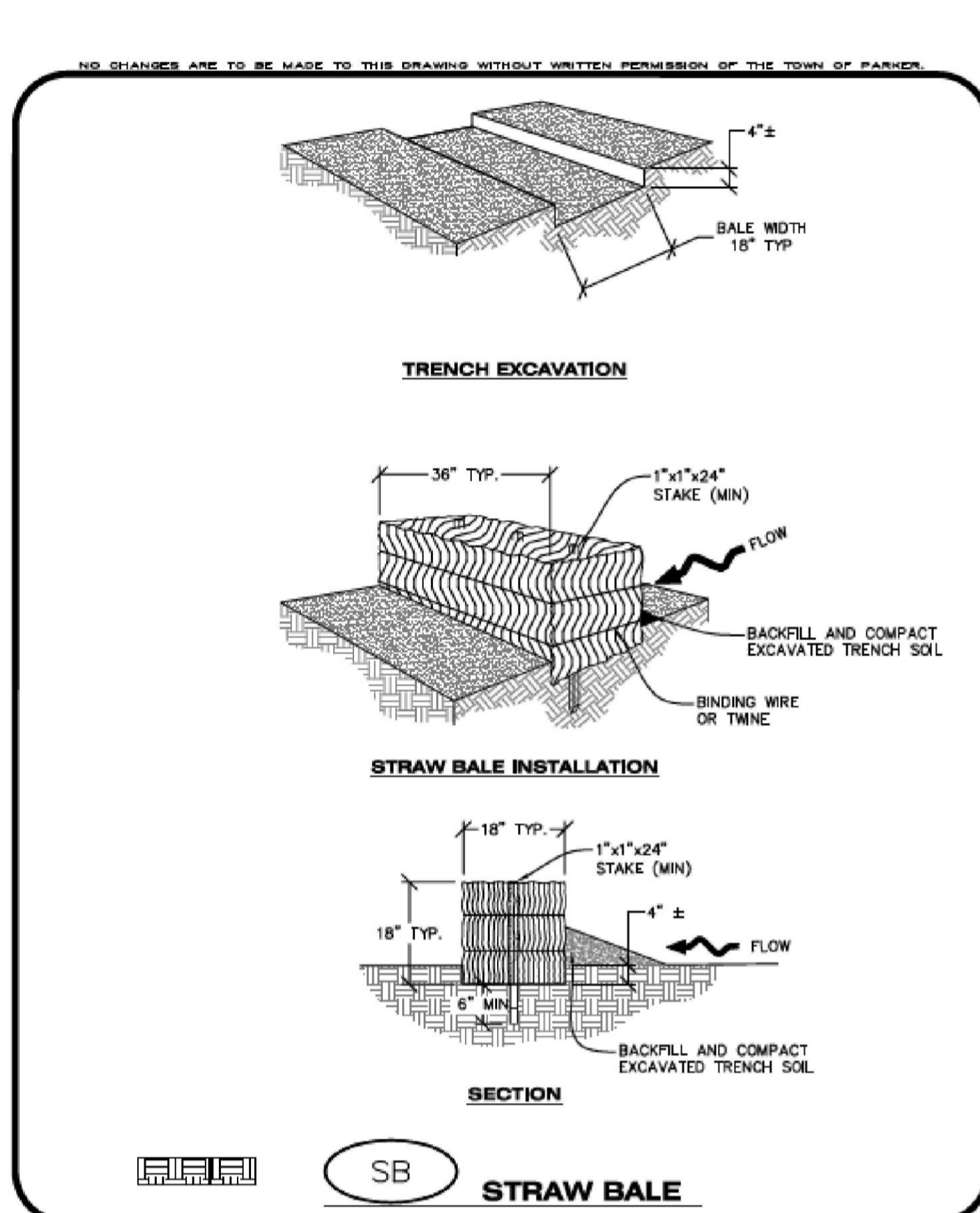
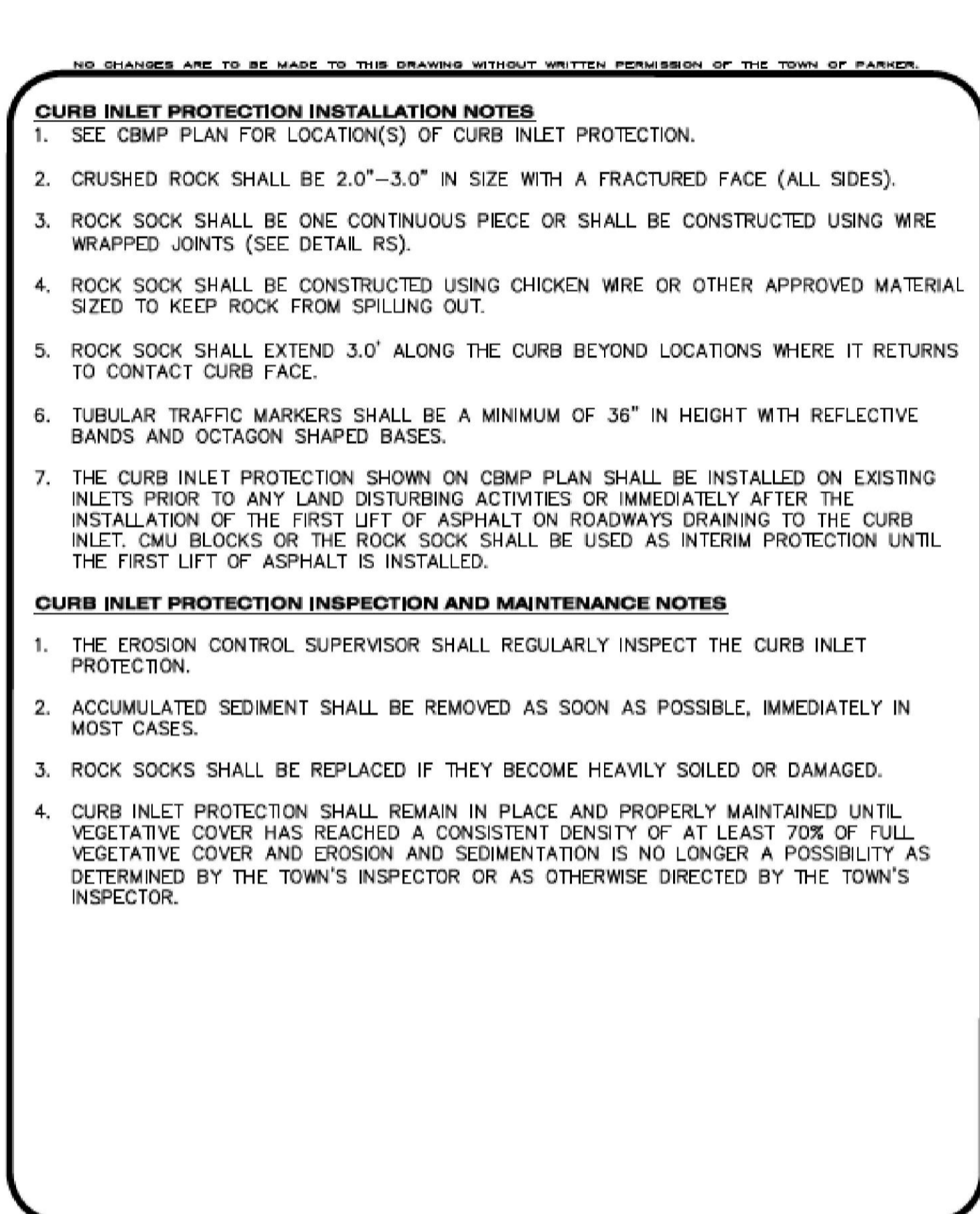
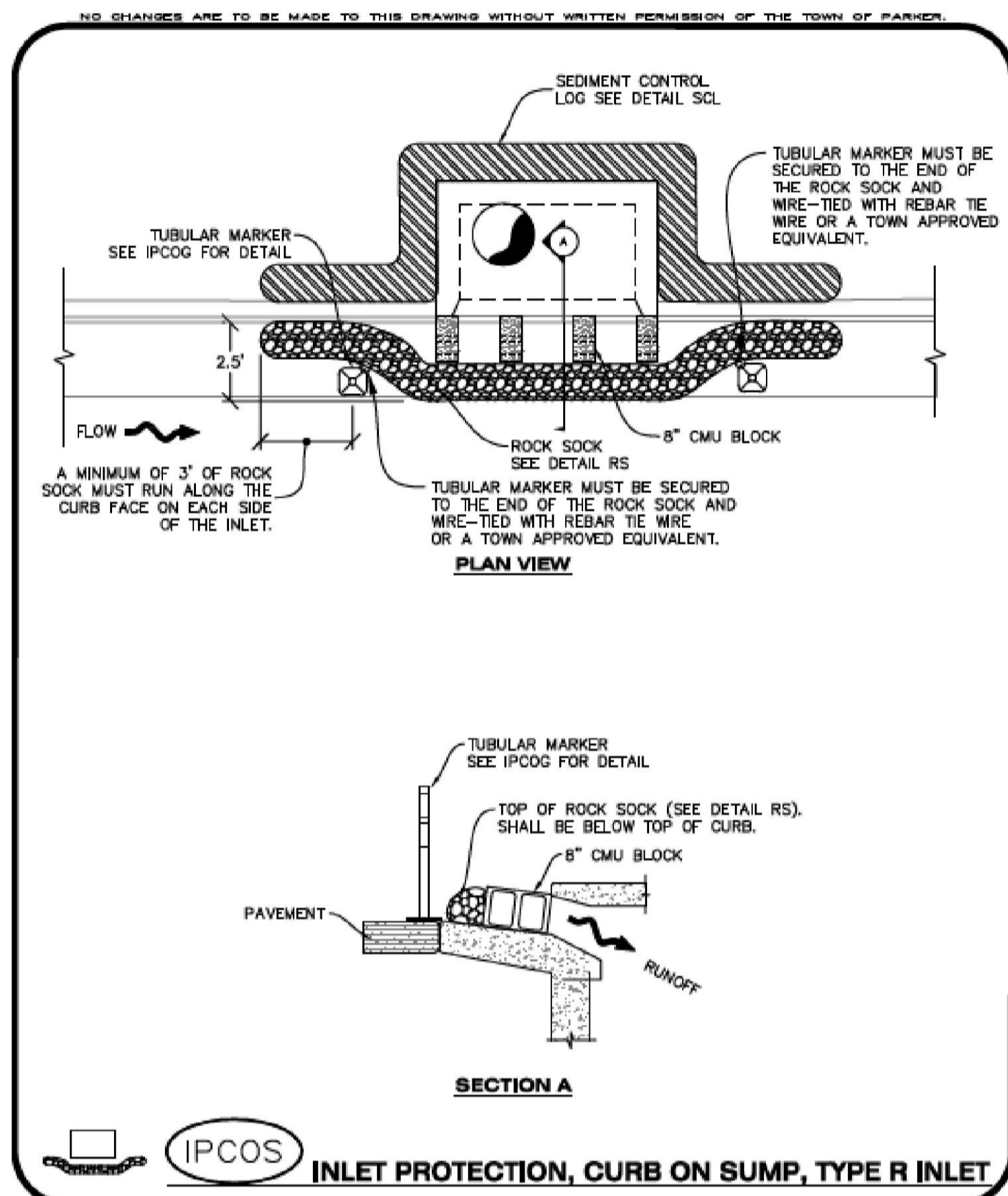

REVISION	DATE	MM&D ENGINEERING SERVICES, INC.
PARKING LOT	09/24/2014	William E. Miller, PE 13389 ENGINEERING
COMMENTS	09/26/2015	CONSTRUCTION MANAGEMENT
		9125 N. Clydesdale Road PH (303) 908-0082
		Castle Rock, Colorado 80108 FAX (303) 708-8399
		Boondocks
		Parker, Colorado
		Sediment & Erosion Control Plan
		Notes & Details
		Construction Plans

DATE 09/16/2014
DES/DF1/GHK_WEM/km
PROJ. NO. 13-343
SHEET 12 OF 24

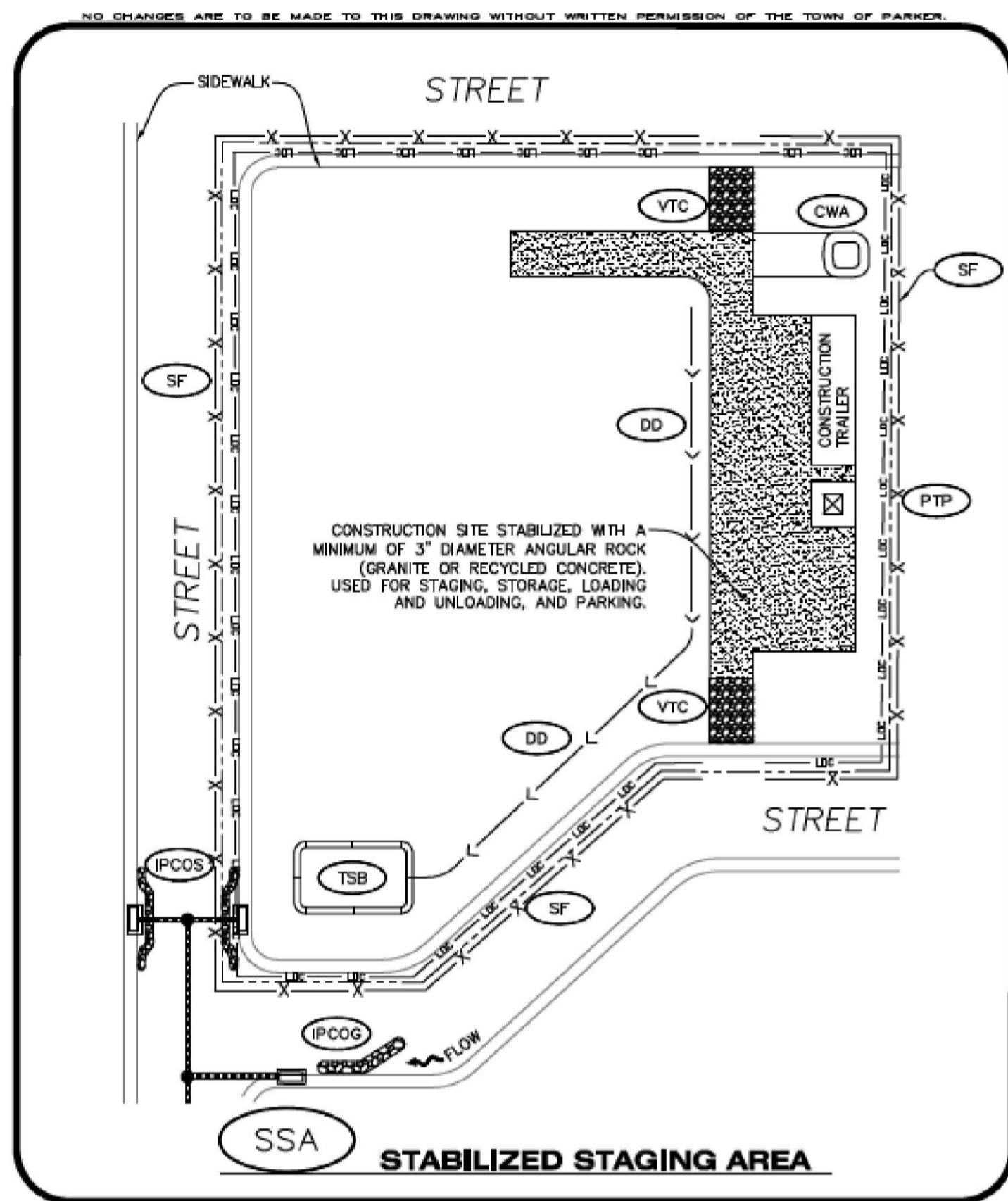

- NO CHANGES ARE TO BE MADE TO THIS DRAWING WITHOUT WRITTEN PERMISSION OF THE TOWN OF PARKER.
- STABILIZED STAGING AREA INSTALLATION NOTES**
1. SEE CBMP PLAN FOR LOCATION OF STAGING AREA. CONTRACTOR MAY MODIFY LOCATION AND SIZE OF STABILIZED STAGING AREA WITH TOWN APPROVAL.
 2. STABILIZED STAGING AREA SHALL BE LARGE ENOUGH TO FULLY CONTAIN PARKING, STORAGE, AND LOADING OPERATIONS.
 3. THE STABILIZED STAGING AREA SHALL CONSIST OF A MINIMUM OF 3" DIAMETER OF ANGULAR ROCK (GRANITE OR RECYCLED CONCRETE).
 4. SSA FOR SMALLER SITES MAY NOT BE PRACTICAL. IN THESE AND SIMILAR SITUATIONS, VARIANCES MAY BE PERMITTED BY THE TOWN.
- STABILIZED STAGING AREA INSPECTION AND MAINTENANCE NOTES**
1. THE EROSION CONTROL SUPERVISOR SHALL REGULARLY INSPECT THE STAGING AREA.
 2. STABILIZED STAGING AREA SHALL BE ENLARGED AS NECESSARY TO CONTAIN PARKING, STORAGE, LOADING, AND UNLOADING.

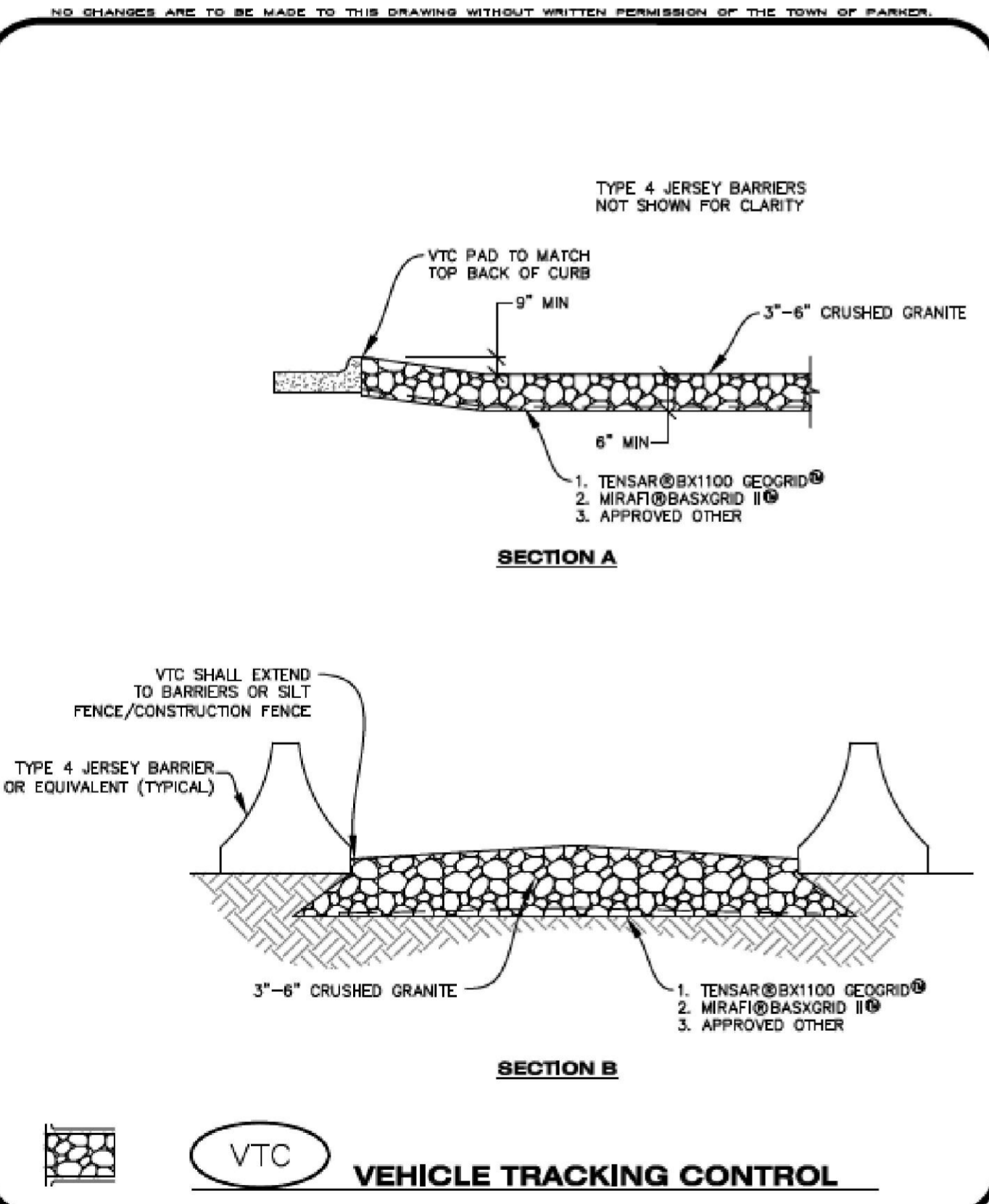
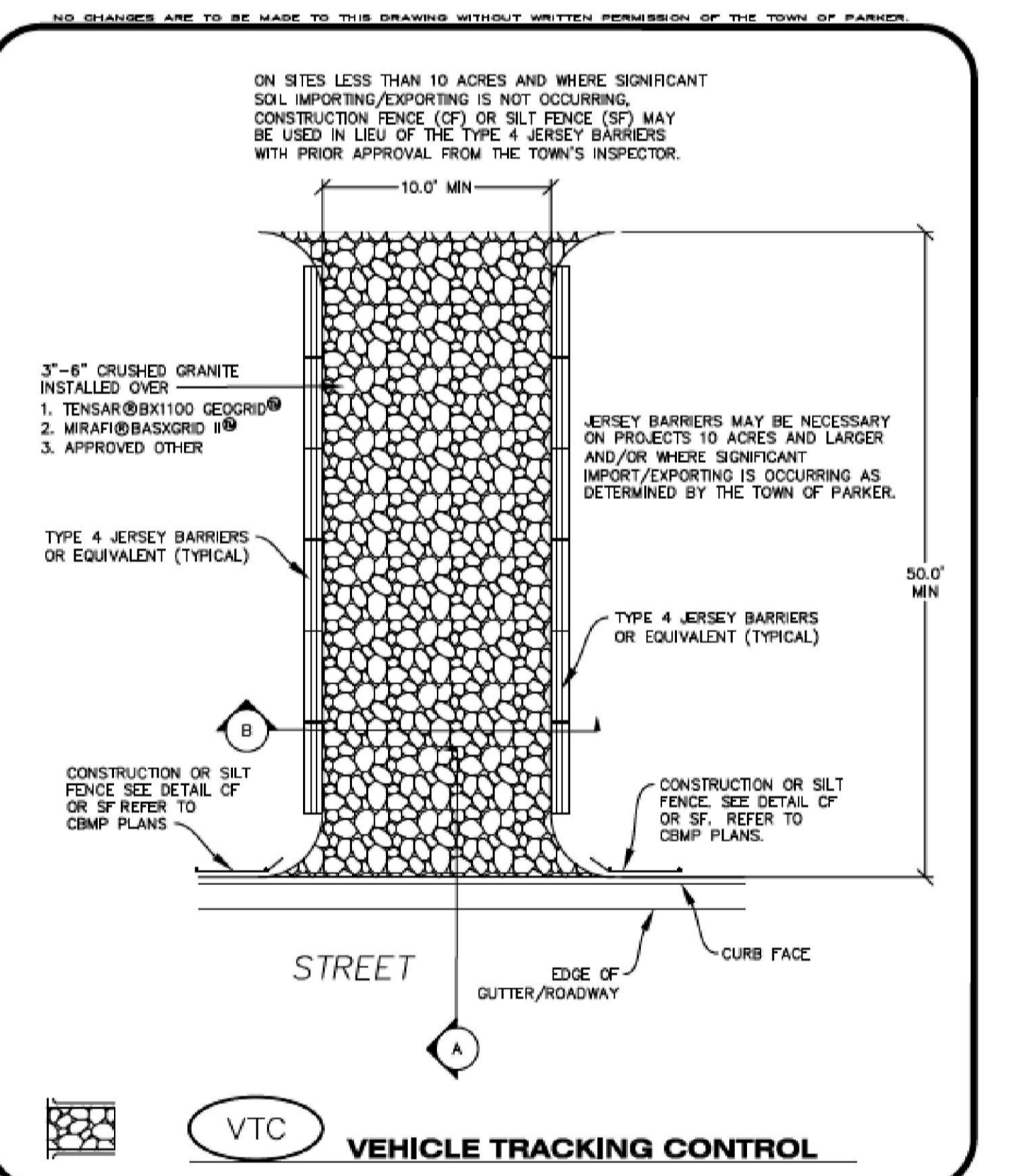
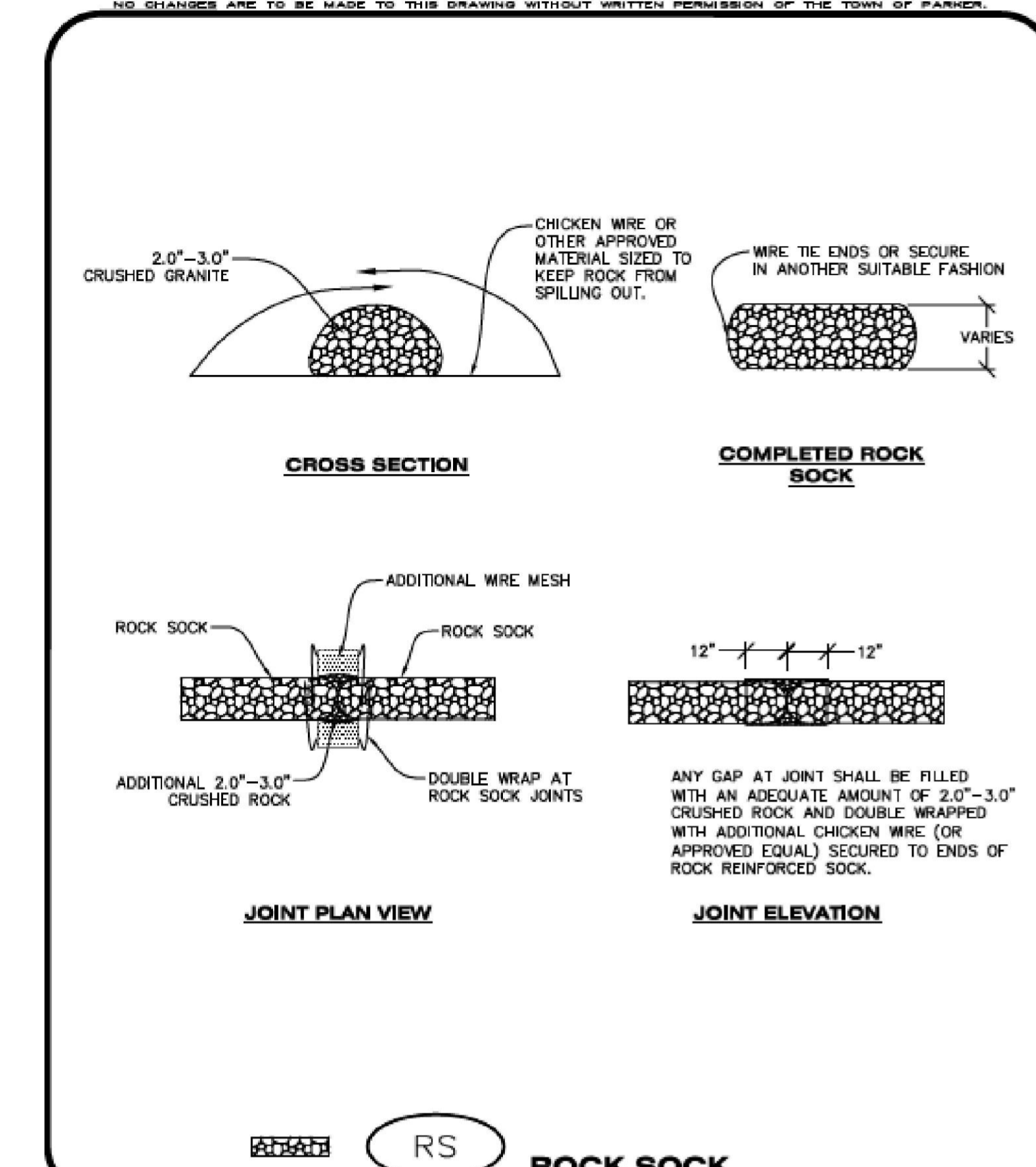
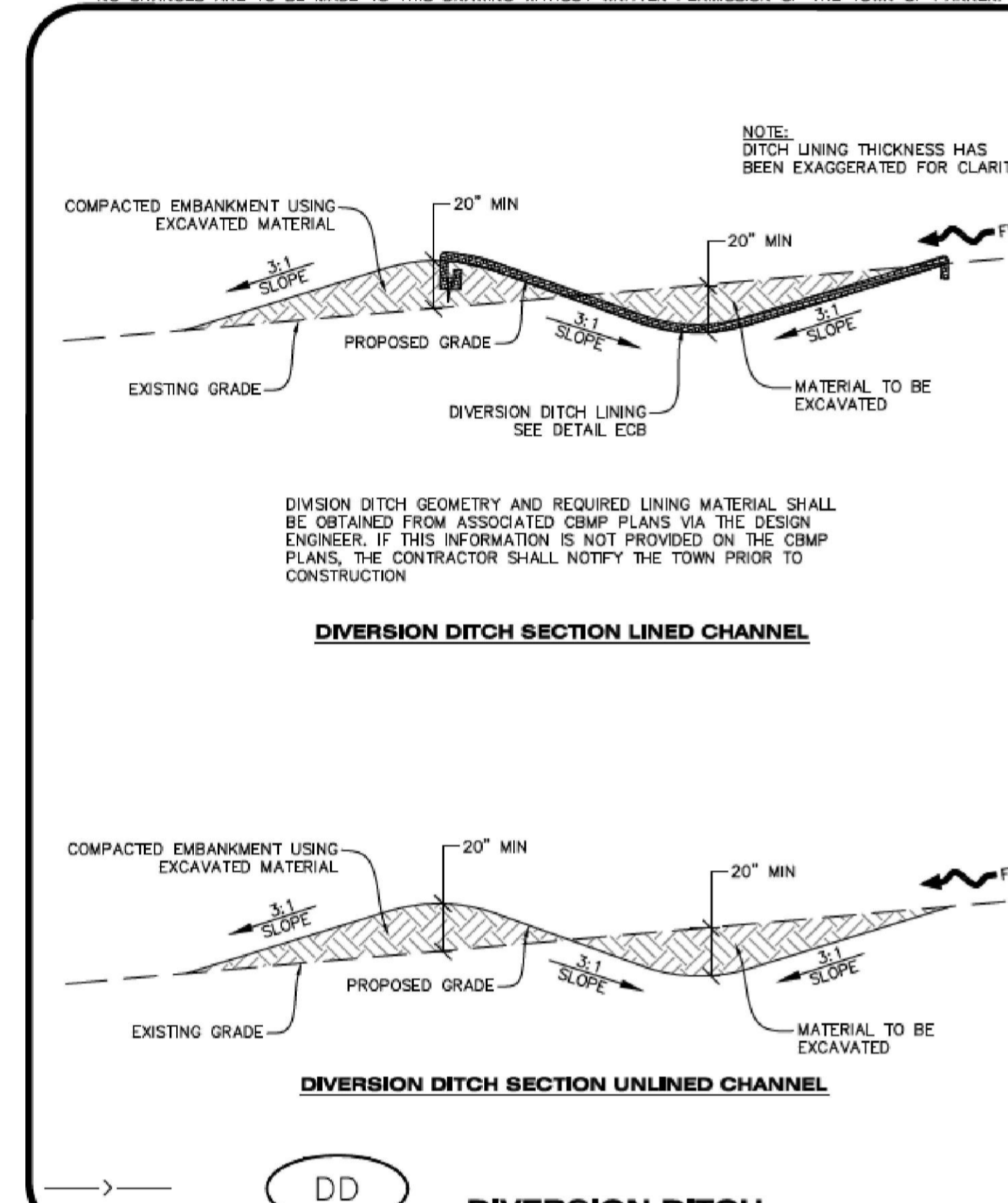

- NO CHANGES ARE TO BE MADE TO THIS DRAWING WITHOUT WRITTEN PERMISSION OF THE TOWN OF PARKER.
- VEHICLE TRACKING CONTROL PAD INSTALLATION NOTES**
1. SEE CBMP PLAN FOR LOCATION(S) OF VEHICLE TRACKING CONTROL PAD(S).
 2. ALL CONSTRUCTION TRAFFIC MUST ENTER AND EXIT THE SITE THROUGH THE APPROVED ACCESS POINT(S). A VEHICLE TRACKING CONTROL PAD IS REQUIRED AT ALL APPROVED ACCESS POINTS TO THE SITE. EXCEPTIONS MAY BE CONSIDERED FOR CONSTRUCTION ACTIVITY OCCURRING IMMEDIATELY ADJACENT TO PAVED AREAS AND WHERE ALTERNATIVE BMP'S ARE IMPLEMENTED. SUCH ACTIVITY MAY INCLUDE, BUT NOT BE LIMITED TO RESIDENTIAL CONSTRUCTION, UTILITY CONSTRUCTION, ETC.
 3. THE VEHICLE TRACKING CONTROL PAD(S) INDICATED ON CBMP PLAN SHALL BE INSTALLED PRIOR TO ANY LAND DISTURBING ACTIVITIES.
 4. VEHICLE TRACKING CONTROL PADS SHALL BE A MINIMUM OF 50-FOOT LONG AND 10-FOOT WIDE, UNLESS A VARIANCE HAS BEEN GRANTED BY THE TOWN'S INSPECTOR.
 5. A BIAXIAL GEO-GRID SHALL BE PLACED UNDER THE VEHICLE TRACKING CONTROL PAD PRIOR TO THE PLACEMENT OF ROCK. THE AREA SHALL BE FREE FROM ANY VOIDS, ROCKS AND DEBRIS. THE BIAXIAL GEO-GRID SHALL BE TENSAR BX1100, MIRAFLO BASKGRID II, OR AN APPROVED EQUAL. GEO-GRID SHALL BE PLACED, AND APPROPRIATELY OVERLAPPED IF NECESSARY, TO COVER THE ENTIRE LENGTH AND WIDTH OF THE VEHICLE TRACKING CONTROL PAD.
 6. CRUSHED ROCK SHALL BE A MINIMUM OF 3-6" GRANITE WITH A FRACTURED FACE (ALL SIDES).
- VEHICLE TRACKING CONTROL PAD INSTALLATION AND MAINTENANCE NOTES**
1. THE EROSION CONTROL SUPERVISOR SHALL REGULARLY INSPECT THE VEHICLE TRACKING CONTROL PAD.
 2. WHEN THE VEHICLE TRACKING CONTROL PAD IS REMOVED, ANY DISTURBED AREAS ASSOCIATED WITH THE INSTALLATION, MAINTENANCE, AND/OR REMOVAL OF THE VEHICLE TRACKING CONTROL PAD SHALL BE ROUGHENED, SEEDED, MULCHED, AND CRIMPED PER THE TOWN'S SPECIFICATIONS (SEE DETAIL SMC).
 3. THE VEHICLE TRACKING CONTROL PAD SHALL BE MAINTAINED SUCH THAT THE ROCK REMAINS RELATIVELY LOOSE AND ACCUMULATED MUD AND OTHER DEBRIS IS REGULARLY REMOVED.

REVISION	DATE	MM&D ENGINEERING SERVICES, INC.
PARKING LOT	09/24/2014	William E. Miller, PE 13389 ENGINEERING
COMMENTS	05/26/2015	CONSTRUCTION MANAGEMENT 9125 N. Clydesdale Road PH (303) 908-0082 Castle Rock, Colorado 80108 FAX (303) 708-8399
		Boondocks Parker, Colorado Sediment & Erosion Control Plan Notes & Details Construction Plans
		DATE 09/16/2014 DES/CHK WEM/km PROJ. NO. 13-343 SHEET 13 OF 24

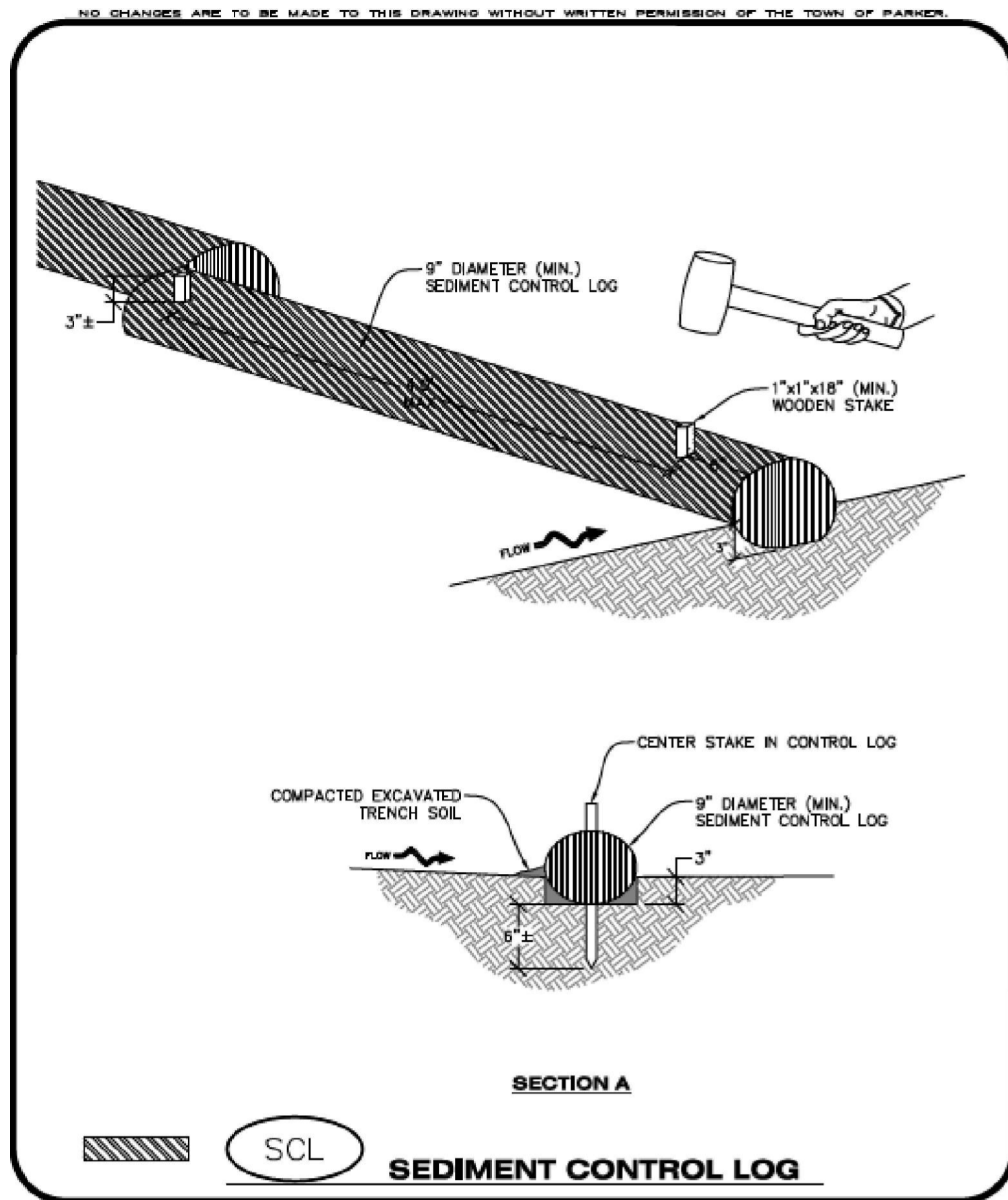

CBMP | SCL | 1 OF 3
CONSTRUCTION BEST MANAGEMENT PRACTICES | Oct. 2013

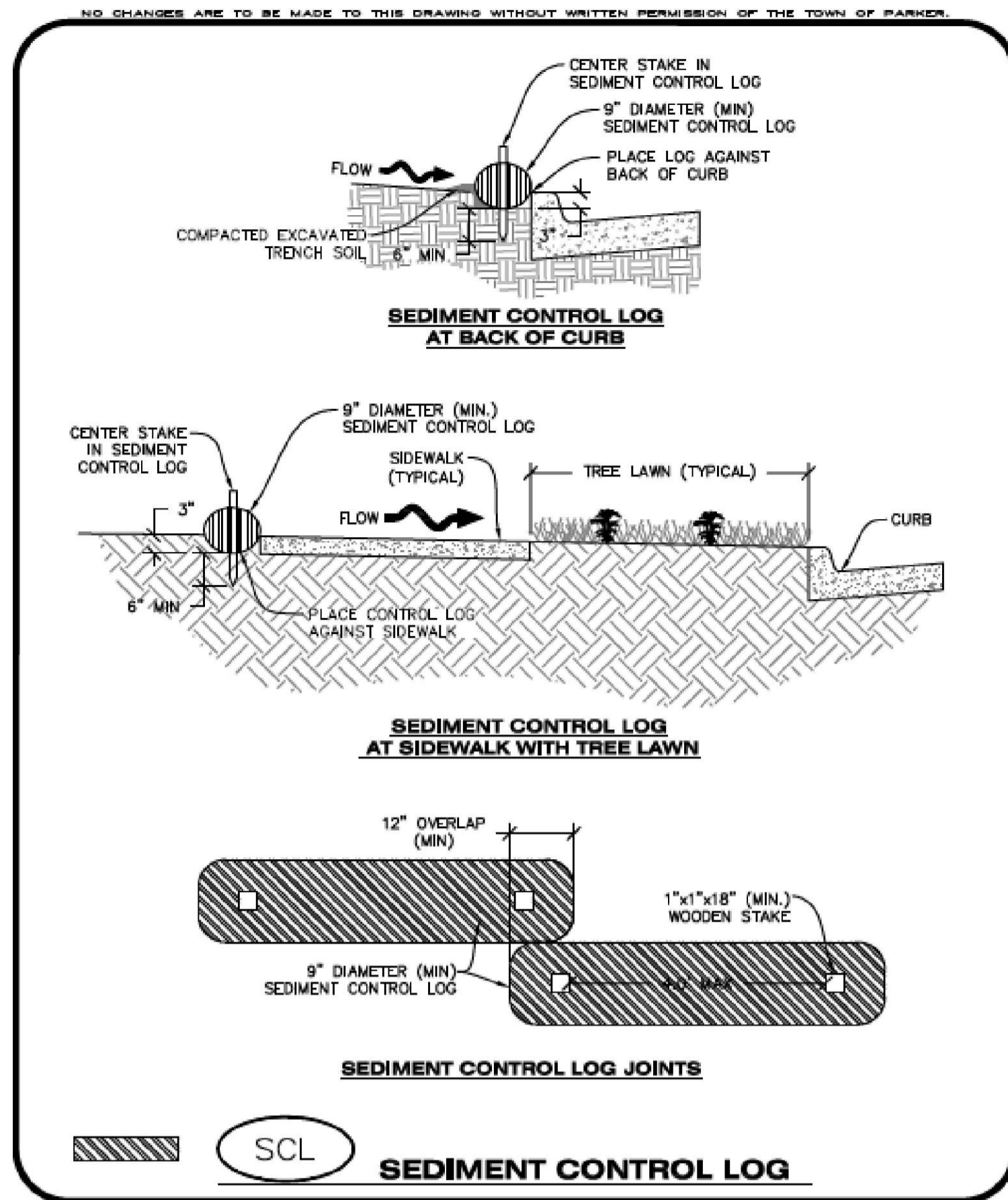

CBMP | SCL | 2 OF 3
CONSTRUCTION BEST MANAGEMENT PRACTICES | Oct. 2013

- NO CHANGES ARE TO BE MADE TO THIS DRAWING WITHOUT WRITTEN PERMISSION OF THE TOWN OF PARKER.
- SEDIMENT CONTROL LOG INSTALLATION NOTES**
- SEE CBMP PLAN FOR LOCATION(S) OF SEDIMENT CONTROL LOGS.
 - ALL SEDIMENT CONTROL LOGS SHALL BE INSTALLED FREE OF DEFECTS INCLUDING RIPS, HOLES AND OBVIOUS WEAR.
 - SEDIMENT CONTROL LOGS SHALL BE INSTALLED IMMEDIATELY ADJACENT TO AN IMPERVIOUS SURFACE SUCH AS A CURB HEAD, SIDEWALK, INLET LID, ETC. NO GAPS SHALL EXIST BETWEEN THE SEDIMENT CONTROL LOG AND THE IMPERVIOUS SURFACE.
 - A UNIFORM 3" DEEP ANCHOR TRENCH (APPROX.) IN THE SHAPE OF A HALF-SPHERE SHALL BE EXCAVATED USING A TRENCHER, SPADE-SHAPED SHOVEL, OR PICK. THE ANCHOR TRENCH SHALL BE SIZED TO ALLOW FOR THE SEDIMENT CONTROL LOG TO SEAT TIGHTLY AGAINST THE ANCHOR TRENCH.
 - EXCAVATED MATERIAL SHALL BE PLACED ON THE UPHILL SIDE OF THE ANCHOR TRENCH AND PROPERLY COMPACTED.
 - ANCHOR TRENCH SHALL BE RELATIVELY FREE OF ROCKS OR OTHER DEBRIS PRIOR TO THE PLACEMENT.
 - ALL SEDIMENT CONTROL LOGS SHALL BE PLACED 3" (APPROX.) BELOW THE GROUND AND PULLED TIGHT ON BOTH ENDS TO REMOVE ANY CURVES OR SNAGS.
 - THE UPHILL SIDE OF THE SEDIMENT CONTROL LOG SHALL BE BACKFILLED WITH SOIL THAT IS RELATIVELY FREE OF ROCKS AND DEBRIS. THE SOIL SHALL BE TIGHTLY COMPACTED AGAINST THE GROUND AND SEDIMENT CONTROL LOG USING A SHOVEL, OR SIMILAR DEVICE.
 - SEDIMENT CONTROL LOG STAKES SHALL BE MADE OF WOOD AND SECURELY ANCHOR THE SCL IN PLACE.
 - STAKES SHALL BE PLACED ON 4.0' CENTERS AND EMBEDDED APPROXIMATELY 6" INTO THE GROUND. STAKES THAT ARE BROKEN PRIOR TO OR DURING INSTALLATION SHALL BE REPLACED.
 - SEDIMENT CONTROL LOGS SHALL OVERLAP A MINIMUM OF 12". THE OVERLAPPING SHALL OCCUR ON THE UP-GRADE SIDE OF THE LOGS.
 - SEDIMENT CONTROL LOGS SHALL BE STAKED WITHIN 6" FROM EACH END.
 - SEDIMENT CONTROL LOGS THAT ARE INSTALLED BEHIND CURBS AND SIDEWALKS MUST BE DONE SO THAT NO MORE THAN A 2" GAP EXISTS BETWEEN THE CONCRETE AND THE LOG. EROSION CONTROL BLANKETING (ECB) BETWEEN THE GAP MAY BE REQUIRED IN INSTANCES WHERE THIS DOES NOT OCCUR.

- SEDIMENT CONTROL LOG INSPECTION AND MAINTENANCE NOTES**
- THE EROSION CONTROL SUPERVISOR SHALL REGULARLY INSPECT THE SEDIMENT CONTROL LOGS.
 - ACCUMULATED SEDIMENT SHALL BE REMOVED ONCE THE SEDIMENT HAS REACHED A DEPTH EQUAL TO 1/2 THE HEIGHT OF EXPOSED LOG.
 - SEDIMENT CONTROL LOGS SHALL REMAIN IN PLACE AND PROPERLY MAINTAINED UNTIL VEGETATIVE COVER HAS REACHED A CONSISTENT DENSITY OF AT LEAST 70% OF FULL VEGETATIVE COVER AND EROSION AND SEDIMENTATION IS NO LONGER A POSSIBILITY AS DETERMINED BY THE TOWN'S INSPECTOR OR AS OTHERWISE DIRECTED BY THE TOWN'S INSPECTOR.
 - SEDIMENT CONTROL LOGS SHALL BE REPLACED WHEN THERE ARE ANY SIGNS OF WEAR OR DAMAGE THAT WOULD PREVENT THE SCL FROM FUNCTIONING AS DESIGNED.
 - WHEN THE SEDIMENT CONTROL LOGS ARE REMOVED, ANY DISTURBED AREAS ASSOCIATED WITH THE INSTALLATION, MAINTENANCE, AND/OR REMOVAL OF THE SEDIMENT CONTROL LOGS MAY NEED TO BE ROUGHENED, SEEDED, MULCHED, AND CRIMPED PER THE TOWN'S SPECIFICATIONS (SEE DETAIL SMC).

CBMP | SCL | 3 OF 3
CONSTRUCTION BEST MANAGEMENT PRACTICES | Oct. 2013

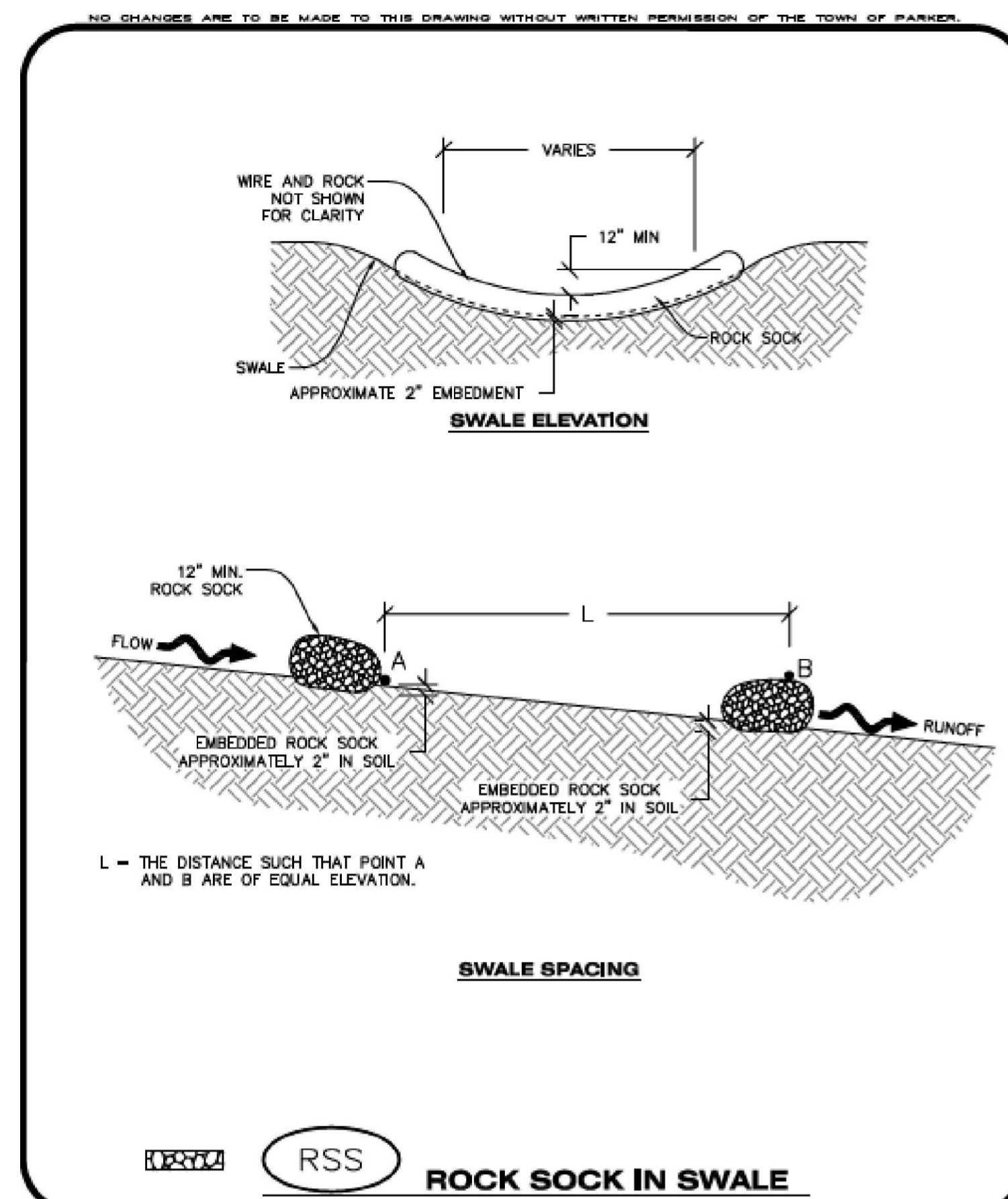

CBMP | RSS | 1 OF 1
CONSTRUCTION BEST MANAGEMENT PRACTICES | Oct. 2013

- NO CHANGES ARE TO BE MADE TO THIS DRAWING WITHOUT WRITTEN PERMISSION OF THE TOWN OF PARKER.
- SEEDING AND MULCHING SHALL BE PERFORMED ACCORDING TO THE ACCOMPANYING DETAIL(S) AND TEXT. NO EXCEPTIONS SHALL BE MADE**
- SEE PLAN VIEW FOR:
 - LOCATION(S) OF SEEDING AND MULCHING
 - TYPE OF SEED MIX
 - SEED MIXES MAY CONFORM TO THE TABLE PROVIDED WITH THE SMC NOTES OR ALTERNATIVES MAY BE ALLOWED WITH PRIOR PERMISSION BY THE TOWN'S INSPECTOR.
 - SEEDING MAY BE PERFORMED YEAR ROUND ASSUMING THE SOIL IS NOT FROZEN. SEEDING DURING TIMES OF EXTREME TEMPERATURES SHOULD BE AVOIDED IF POSSIBLE.
 - AT THE BEGINNING OF THE LAND DISTURBANCE ACTIVITIES, IT IS HIGHLY RECOMMENDED THAT AN APPROPRIATE AMOUNT OF NATIVE TOPSOIL BE STRIPPED FROM THE SITE AND STOCKPILED. ALL AREAS, PRIOR TO PERMANENT SEEDING AND MULCHING, WILL LIKELY NEED TO BE COVERED WITH AN APPROPRIATE LAYER OF TOPSOIL. THIS REQUIREMENT APPLIES TO ALL AREAS WHERE NATIVE SEEDING IS SPECIFIED ON THE CBMP PLAN AND/OR LANDSCAPING PLANS.
 - IT IS STRONGLY RECOMMENDED THAT SAMPLES FROM THE STRIPPED TOPSOIL BE PROPERLY COLLECTED AND TESTED BY A QUALIFIED LABORATORY TO ENSURE ADEQUATE NUTRIENT CONTENT PRIOR TO SEEDING AND MULCHING. IF IT IS DISCOVERED THAT THE TOPSOIL IS VOID OF THE NUTRIENTS NECESSARY TO SUCCESSFULLY ESTABLISH THE REQUIRED VEGETATION, THEN THE APPROPRIATE AMENDMENTS SHALL BE ADDED.
 - ALL AREAS TO BE SEEDED AND MULCHED SHALL BE SURFACE ROUGHENED ACCORDING TO THE SURFACE ROUGHENING DETAILS AND NOTES. SURFACE ROUGHENING SHALL OCCUR AFTER PLACEMENT OF THE TOPSOIL.
 - WHEN INSTALLED WITH A DRILL SEEDER, SEED SHALL BE PLACED AT A DEPTH OF 1/4 - 1/2 INCH. ROW SPACING SHALL BE NO MORE THAN 6-INCHES.
 - ALL AREAS INCAPABLE OF BEING DRILL SEEDED SHALL BE SURFACE ROUGHENED ACCORDING TO THE SURFACE ROUGHENING NOTES OR EFFECTIVELY ROUGHENED USING A HARROW OR OTHER SUCH IMPLEMENT. ALL AREAS SHALL BE UNIFORMLY HAND BROADCASTED WITH THE PROPER SEED MIX APPLIED AT TWO TIMES THE DRILL SEEDED RATE. BROADCASTED AREAS SHALL THEN BE RE-HARROWED OR RE-RAKED USING A HARD-TIPPED RAKE TO ENSURE THAT SEEDS ARE BURIED TO AN APPROXIMATE DEPTH OF 1/4 - 1/2 INCH.
 - AFTER SEEDING HAS BEEN COMPLETED, MULCH SHALL BE UNIFORMLY APPLIED AT A RATE OF 2 TONS/ACRE (4,000 LBS./ACRE). MULCH SHALL BE MECHANICALLY CRIMPED TO A DEPTH OF 2 INCHES USING A CRIMPER. MULCH SHALL BE HAND CRIMPED AND COVERED WITH A TACKIFIER IN AREAS WHERE MECHANICAL CRIMPING IS NOT POSSIBLE. WHEN SOILS PERMIT, ALL MULCH SHALL BE CRIMPED SUCH THAT THE INDIVIDUAL PIECES OF STRAW OR HAY FORM EXAGGERATED V-SHAPES PROTRUDING OUT OF THE GROUND SEVERAL INCHES.
 - IN CERTAIN INSTANCES, IT MAY BE NECESSARY TO APPLY A TACKIFIER IN ORDER TO HELP WITH STRAW DISPLACEMENT. TACKIFIER SHALL BE APPLIED ACCORDING TO THE MANUFACTURER'S SPECIFICATIONS.

CBMP | SMC | 1 OF 3
CONSTRUCTION BEST MANAGEMENT PRACTICES | Oct. 2013

- NO CHANGES ARE TO BE MADE TO THIS DRAWING WITHOUT WRITTEN PERMISSION OF THE TOWN OF PARKER.
- SEEDING AND MULCHING MAINTENANCE NOTES**
- THE EROSION CONTROL SUPERVISOR SHALL REGULARLY INSPECT THE SEEDING AND MULCHING.
 - ANY SEEDED AND MULCHED AREAS THAT BECOME DAMAGED SHALL BE REPAIRED WITHIN THE TIME FRAME SPECIFIED BY THE TOWN'S INSPECTOR.
- WEED MANAGEMENT**
- ALL HERBICIDES SHALL BE APPLIED BY COMMERCIAL PESTICIDE APPLICATORS LICENSED BY THE COLORADO DEPARTMENT OF AGRICULTURE AS QUALIFIED APPLICATORS. THE CONTRACTOR SHALL FURNISH DOCUMENTATION OF SUCH LICENSING PRIOR TO HERBICIDE APPLICATION.
 - HERBICIDE APPLICATION METHOD SHALL BE SUCH THAT PLANT GROWTH OUTSIDE THE DESIGNATED TREATMENT AREAS WILL NOT BE DAMAGED. ALL DAMAGE CAUSED BY IMPROPER HERBICIDE APPLICATION SHALL BE REPAIRED AT THE CONTRACTOR'S EXPENSE.
 - HERBICIDES SHALL BE APPLIED DURING THE APPROPRIATE SEASONS, WHEN TARGET PLANTS ARE ACTIVELY GROWING.
 - AFTER THE GRASS SEED IS ESTABLISHED, APPROPRIATE HERBICIDES SHALL BE APPLIED TO CONTROL THE REMAINING WEEDS TO ENSURE A TIMELY RETURN OF THE FINANCIAL SECURITY. PROPER TIMING OF HERBICIDE APPLICATIONS ARE NECESSARY TO ACHIEVE THE SUPPRESSION OF WEED SEED PRODUCTION AND DEPLETION OF WEED ROOT MASS. ULTIMATELY, THE HERBICIDES USED SHALL BE BASED UPON THE TARGET WEEDS.
 - HERBICIDE TREATMENTS SHALL CONTINUE AT AN APPROPRIATE RATE UNTIL IT IS EVIDENT THAT WEED GROWTH PRESENCE AND GROWTH IS MINIMAL AND MAY BE CONTROLLED THROUGH MOWING AND/OR ANNUAL HERBICIDE TREATMENT.

CBMP | SMC | 2 OF 3
CONSTRUCTION BEST MANAGEMENT PRACTICES | Oct. 2013

- NO CHANGES ARE TO BE MADE TO THIS DRAWING WITHOUT WRITTEN PERMISSION OF THE TOWN OF PARKER.
- TOWN OF PARKER, SEED MIX 1**
- 20% CANADA WILDRYE
 - 15% CRESTED WHEATGRASS
 - 15% SLENDER WHEATGRASS
 - 10% ANNUAL RYEGRASS
 - 10% SHEEP FESCUE
 - 10% BIG BLUESTEM
 - 10% SIDCOATS GRAMA
 - 5% CANADA BLUEGRASS
 - 5% BLUE GRAMA
- SEEDING RATE:**
DRILLED: 25 LBS./ACRE
BROADCAST: 50 LBS./ACRE
- TOWN OF PARKER, SEED MIX 2**
- 22% SLENDER WHEATGRASS
 - 18% SODAR STREAMBANK WHEATGRASS
 - 13% ARIZONA FESCUE
 - 13% BLUE GRAMA
 - 12% BUFFALOGRASS
 - 12% BARLEY OR OATS
 - 5% SPIKE MUHLY
 - 5% INDIAN RICEGRASS
- SEEDING RATE:**
DRILLED: 25 LBS./ACRE
BROADCAST: 50 LBS./ACRE
- TOWN OF PARKER, SEED MIX 3 (LOW-GROWTH MIX)**
- 25% EPHRAIM CRESTED WHEATGRASS
 - 23% SHEEP FESCUE
 - 18% PERENNIAL RYEGRASS
 - 13% CANADA BLUEGRASS
 - 12% BARLEY OR OATS
 - 9% BLUE FESCUE
- SEEDING RATE:**
DRILLED: 25 LBS./ACRE
BROADCAST: 50 LBS./ACRE
- SEED MIX 4:**
OTHER SEED MIXES APPROVED BY THE TOWN OF PARKER

CBMP | SMC | 3 OF 3
CONSTRUCTION BEST MANAGEMENT PRACTICES | Oct. 2013

REVISION	DATE	MM&D ENGINEERING SERVICES, INC.
PARKING LOT	09/24/2014	
COMMENTS	05/26/2015	
William E. Miller, PE 13389 ENGINEERING CONSTRUCTION MANAGEMENT 9125 N. Clydesdale Road PH (303) 908-0082 Castle Rock, Colorado 80108 FAX (303) 708-8399		Boondocks Parker, Colorado Sediment & Erosion Control Plan Notes & Details Construction Plans
William E. Miller, PE 13389 ENGINEERING CONSTRUCTION MANAGEMENT 9125 N. Clydesdale Road PH (303) 908-0082 Castle Rock, Colorado 80108 FAX (303) 708-8399		
Boondocks Parker, Colorado Sediment & Erosion Control Plan Notes & Details Construction Plans		DATE 09/16/2014 DES/DFI/CHK. WEM/km PROJ. NO. 13-343 SHEET 14 OF 24

SEEDING AND MULCHING SHALL BE PERFORMED ACCORDING TO THE ACCOMPANYING DETAIL(S) AND TEXT. NO EXCEPTIONS SHALL BE MADE

- SEE PLAN VIEW FOR:
 - LOCATION(S) OF SEEDING AND MULCHING
 - TYPE OF SEED MIX
- SEED MIXES MAY CONFORM TO THE TABLE PROVIDED WITH THE SMC NOTES OR ALTERNATIVES MAY BE ALLOWED WITH PRIOR PERMISSION BY THE TOWN'S INSPECTOR.
- SEEDING MAY BE PERFORMED YEAR ROUND ASSUMING THE SOIL IS NOT FROZEN. SEEDING DURING TIMES OF EXTREME TEMPERATURES SHOULD BE AVOIDED IF POSSIBLE.
- AT THE BEGINNING OF THE LAND DISTURBANCE ACTIVITIES, IT IS HIGHLY RECOMMENDED THAT AN APPROPRIATE AMOUNT OF NATIVE TOPSOIL BE STRIPPED FROM THE SITE AND STOCKPILED. ALL AREAS, PRIOR TO PERMANENT SEEDING AND MULCHING, WILL LIKELY NEED TO BE COVERED WITH AN APPROPRIATE LAYER OF TOPSOIL. THIS REQUIREMENT APPLIES TO ALL AREAS WHERE NATIVE SEEDING IS SPECIFIED ON THE CBMP PLAN AND/OR LANDSCAPING PLANS.
- IT IS STRONGLY RECOMMENDED THAT SAMPLES FROM THE STRIPPED TOPSOIL BE PROPERLY COLLECTED AND TESTED BY A QUALIFIED LABORATORY TO ENSURE ADEQUATE NUTRIENT CONTENT PRIOR TO SEEDING AND MULCHING. IF IT IS DISCOVERED THAT THE TOPSOIL IS VOID OF THE NUTRIENTS NECESSARY TO SUCCESSFULLY ESTABLISH THE REQUIRED VEGETATION, THEN THE APPROPRIATE AMENDMENTS SHALL BE ADDED.
- ALL AREAS TO BE SEEDED AND MULCHED SHALL BE SURFACE ROUGHENED ACCORDING TO THE SURFACE ROUGHENING DETAILS AND NOTES. SURFACE ROUGHENING SHALL OCCUR AFTER PLACEMENT OF THE TOPSOIL.
- WHEN INSTALLED WITH A DRILL SEEDER, SEED SHALL BE PLACED AT A DEPTH OF ¼ - ½ INCH. ROW SPACING SHALL BE NO MORE THAN 6-INCHES.
- ALL AREAS INCAPABLE OF BEING DRILL SEEDED SHALL BE SURFACE ROUGHENED ACCORDING TO THE SURFACE ROUGHENING NOTES OR EFFECTIVELY ROUGHENED USING A HARROW OR OTHER SUCH IMPLEMENT. ALL AREAS SHALL BE UNIFORMLY HAND BROADCASTED WITH THE PROPER SEED MIX APPLIED AT TWO TIMES THE DRILL SEEDED RATE. BROADCASTED AREAS SHALL THEN BE RE-HARROWED OR RE-RAKED USING A HARD-TIPPED RAKE TO ENSURE THAT SEEDS ARE BURIED TO AN APPROXIMATE DEPTH OF ¼ - ½ INCH.
- AFTER SEEDING HAS BEEN COMPLETED, MULCH SHALL BE UNIFORMLY APPLIED AT A RATE OF 2 TONS/ACRE (4,000 LBS/ACRE). MULCH SHALL BE MECHANICALLY CRIMPED TO A DEPTH OF 2 INCHES USING A CRIMPER. MULCH SHALL BE HAND CRIMPED AND COVERED WITH A TACKIFIER IN AREAS WHERE MECHANICAL CRIMPING IS NOT POSSIBLE. WHEN SOILS PERMIT, ALL MULCH SHALL BE CRIMPED SUCH THAT THE INDIVIDUAL PIECES OF STRAW OR HAY FORM EXAGGERATED V-SHAPES PROTRUDING OUT OF THE GROUND SEVERAL INCHES.
- IN CERTAIN INSTANCES, IT MAY BE NECESSARY TO APPLY A TACKIFIER IN ORDER TO HELP WITH STRAW DISPLACEMENT. TACKIFIER SHALL BE APPLIED ACCORDING TO THE MANUFACTURER'S SPECIFICATIONS.

SEEDING AND MULCHING MAINTENANCE NOTES

- THE EROSION CONTROL SUPERVISOR SHALL REGULARLY INSPECT THE SEEDING AND MULCHING.
 - ANY SEEDED AND MULCHED AREAS THAT BECOME DAMAGED SHALL BE REPAIRED WITHIN THE TIME FRAME SPECIFIED BY THE TOWN'S INSPECTOR.
- WEED MANAGEMENT**
- ALL HERBICIDES SHALL BE APPLIED BY COMMERCIAL PESTICIDE APPLICATORS LICENSED BY THE COLORADO DEPARTMENT OF AGRICULTURE AS QUALIFIED APPLICATORS. THE CONTRACTOR SHALL FURNISH DOCUMENTATION OF SUCH LICENSING PRIOR TO HERBICIDE APPLICATION.
 - HERBICIDE APPLICATION METHOD SHALL BE SUCH THAT PLANT GROWTH OUTSIDE THE DESIGNATED TREATMENT AREAS WILL NOT BE DAMAGED. ALL DAMAGE CAUSED BY IMPROPER HERBICIDE APPLICATION SHALL BE REPAIRED AT THE CONTRACTOR'S EXPENSE.
 - HERBICIDES SHALL BE APPLIED DURING THE APPROPRIATE SEASONS, WHEN TARGET PLANTS ARE ACTIVELY GROWING.
 - AFTER THE GRASS SEED IS ESTABLISHED, APPROPRIATE HERBICIDES SHALL BE APPLIED TO CONTROL THE REMAINING WEEDS TO ENSURE A TIMELY RETURN OF THE FINANCIAL SECURITY. PROPER TIMING OF HERBICIDE APPLICATIONS ARE NECESSARY TO ACHIEVE THE SUPPRESSION OF WEED SEED PRODUCTION AND DEPLETION OF WEED ROOT MASS. ULTIMATELY, THE HERBICIDES USED SHALL BE BASED UPON THE TARGET WEEDS.
 - HERBICIDE TREATMENTS SHALL CONTINUE AT AN APPROPRIATE RATE UNTIL IT IS EVIDENT THAT WEED GROWTH PRESENCE AND GROWTH IS MINIMAL AND MAY BE CONTROLLED THROUGH MOWING AND/OR ANNUAL HERBICIDE TREATMENT.

TOWN OF PARKER, SEED MIX 1

- 20% CANADA WLDRYE
- 15% CRESTED WHEATGRASS
- 15% SLENDER WHEATGRASS
- 10% ANNUAL RYEGRASS
- 10% SHEEP FESCUE
- 10% BIG BLUESTEM
- 10% SIDEDOTS GRAMA
- 5% CANADA BLUEGRASS
- 5% BLUE GRAMA

SEEDING RATE:
 DRILLED: 25 LBS/ACRE
 BROADCAST: 50 LBS/ACRE

TOWN OF PARKER, SEED MIX 2

- 22% SLENDER WHEATGRASS
- 18% SODAR STREAMBANK WHEATGRASS
- 13% ARIZONA FESCUE
- 13% BLUE GRAMA
- 12% BUFFALOGRASS
- 12% BARLEY OR OATS
- 5% SPIKE MUHLY
- 5% INDIAN RICEGRASS

SEEDING RATE:
 DRILLED: 25 LBS/ACRE
 BROADCAST: 50 LBS/ACRE

TOWN OF PARKER, SEED MIX 3 (LOW-GROWTH MIX)

- 25% EPHRAIM CRESTED WHEATGRASS
- 23% SHEEP FESCUE
- 18% PERENNIAL RYEGRASS
- 13% CANADA BLUEGRASS
- 12% BARLEY OR OATS
- 9% BLUE FESCUE

SEEDING RATE:
 DRILLED: 25 LBS/ACRE
 BROADCAST: 50 LBS/ACRE

SEED MIX 4:
 OTHER SEED MIXES APPROVED BY THE TOWN OF PARKER



CBMP
 CONSTRUCTION BEST MANAGEMENT PRACTICES

SMC
 1 OF 3
 Oct. 2013



CBMP
 CONSTRUCTION BEST MANAGEMENT PRACTICES

SMC
 2 OF 3
 Oct. 2013



CBMP
 CONSTRUCTION BEST MANAGEMENT PRACTICES

SMC
 3 OF 3
 Oct. 2013

REVISION	DATE	MM&D ENGINEERING SERVICES, INC.
PARKING LOT	09/24/2014	
COMMENTS	05/26/2015	William E. Miller, PE 13389 ENGINEERING CONSTRUCTION MANAGEMENT 9125 N. Clydesdale Road PH (303) 908-0082 Castle Rock, Colorado 80108 FAX (303) 708-8399
		Boondocks Parker, Colorado Sediment & Erosion Control Plan Notes & Details Construction Plans
		DATE 09/16/2014
		DWG/DF1/GHK_WEM/km
		PROJ. NO. 13-343
		SHEET 15 OF 24

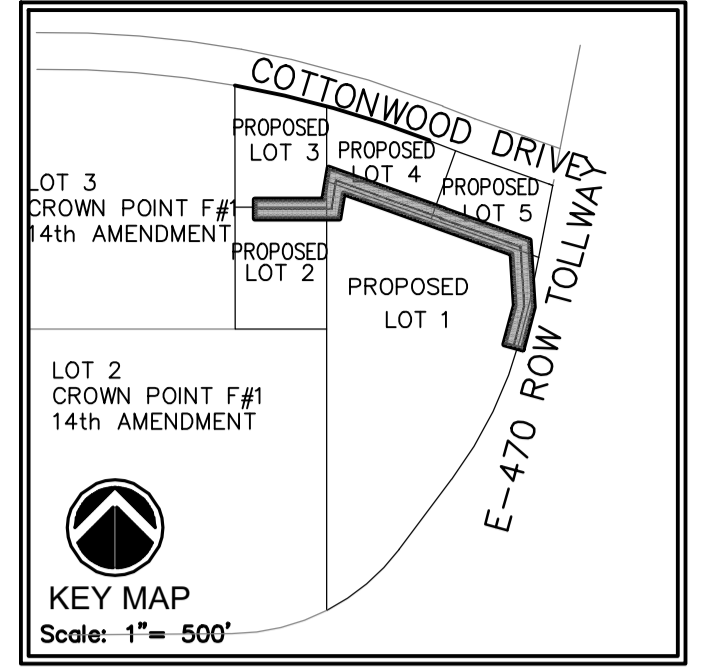
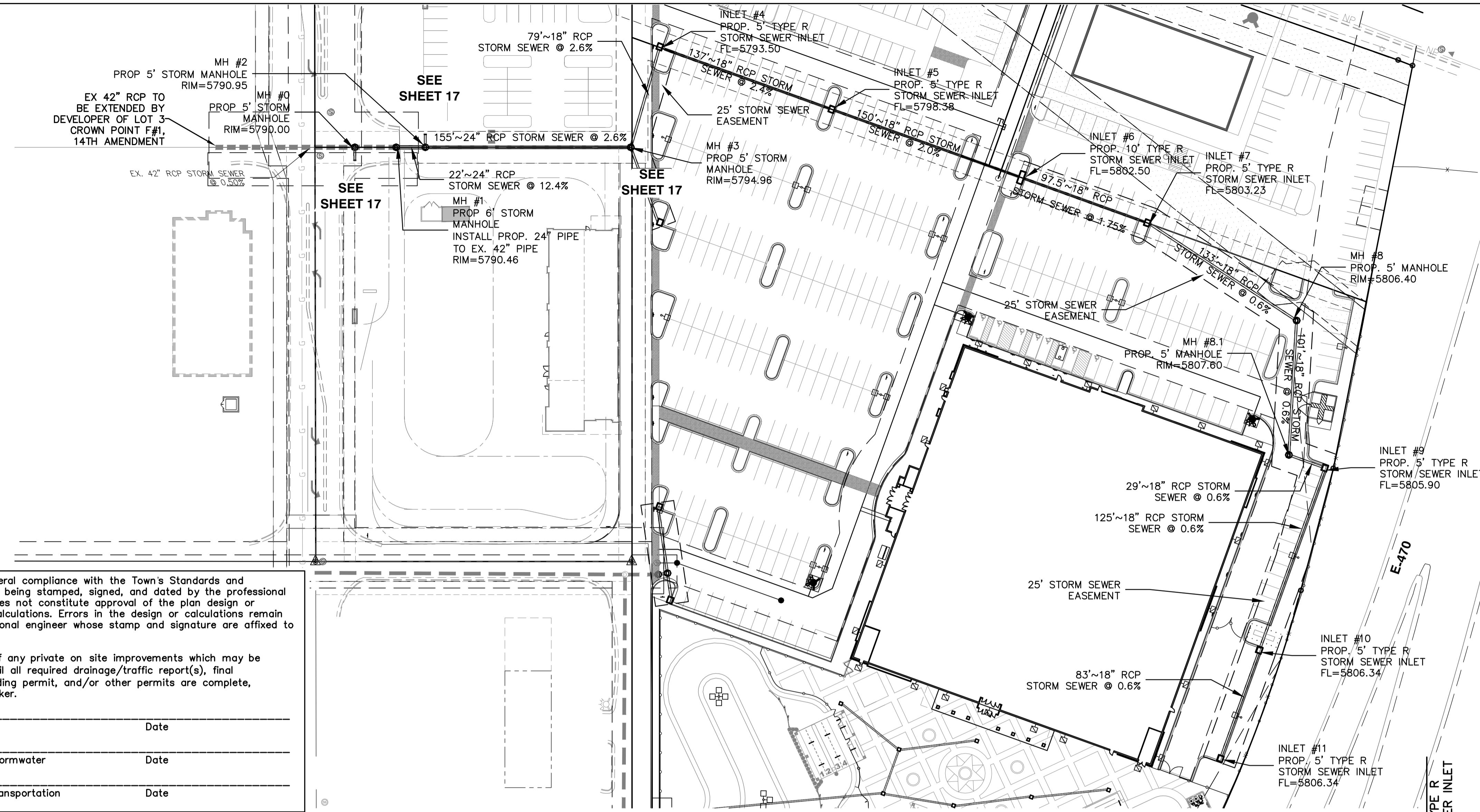

The Town of Parker review constitutes general compliance with the Town's Standards and approved variances, subject to these plans being stamped, signed, and dated by the professional engineer of record. Review by the Town does not constitute approval of the plan design or accuracy and correctness of engineering calculations. Errors in the design or calculations remain the responsibility of the registered professional engineer whose stamp and signature are affixed to this document.

This review does not constitute approval of any private on site improvements which may be shown. Construction cannot commence until all required drainage/traffic report(s), final development plan(s), special review(s), grading permit, and/or other permits are complete, approved and on file with the Town of Parker.

Town of Parker, Public Works Director	Date
Town of Parker, Public Works Manager - Stormwater	Date
Town of Parker, Public Works Manager - Transportation	Date



Know what's below. Call before you dig.

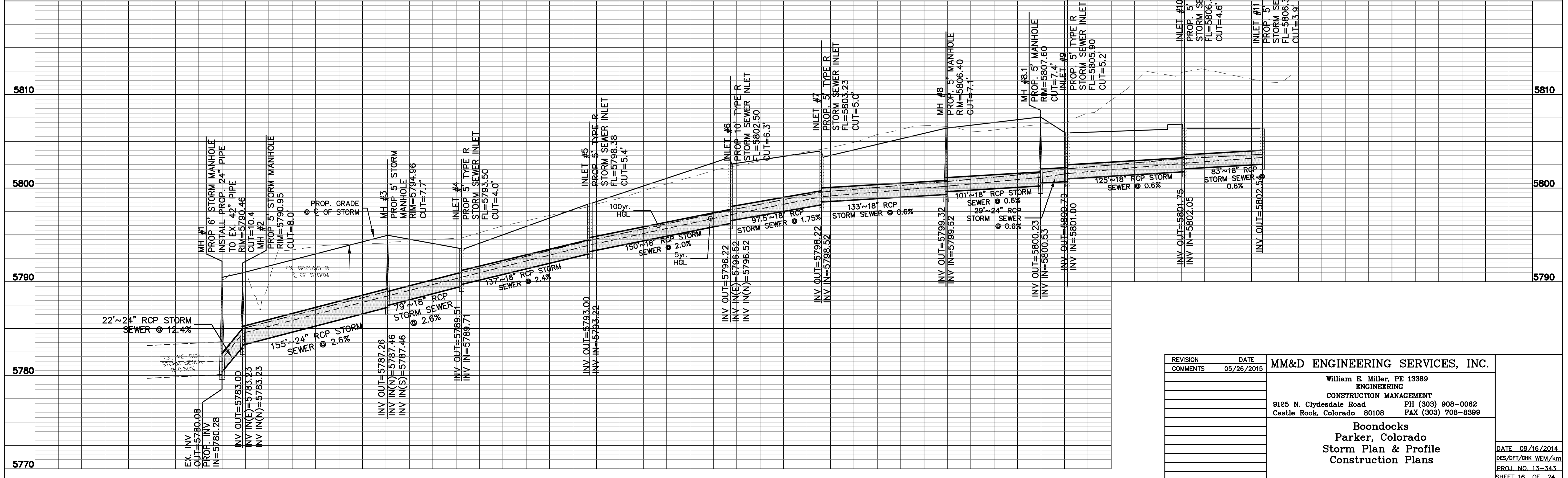
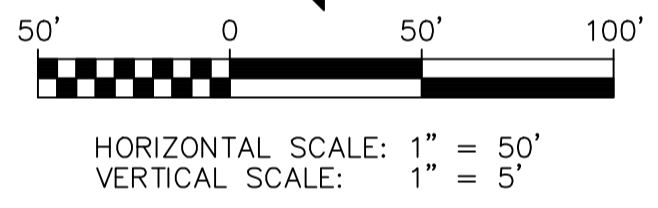

REVISION	DATE	MM&D ENGINEERING SERVICES, INC.
COMMENTS	05/26/2015	
		William E. Miller, PE 13389 ENGINEERING CONSTRUCTION MANAGEMENT 9125 N. Clydesdale Road PH (303) 908-0082 Castle Rock, Colorado 80108 FAX (303) 708-8399
		Boondocks Parker, Colorado Storm Plan & Profile Construction Plans
		DATE 09/16/2014 DES/DET/CHK WEM/km PROJ. NO. 13-343 SHEET 16 OF 24

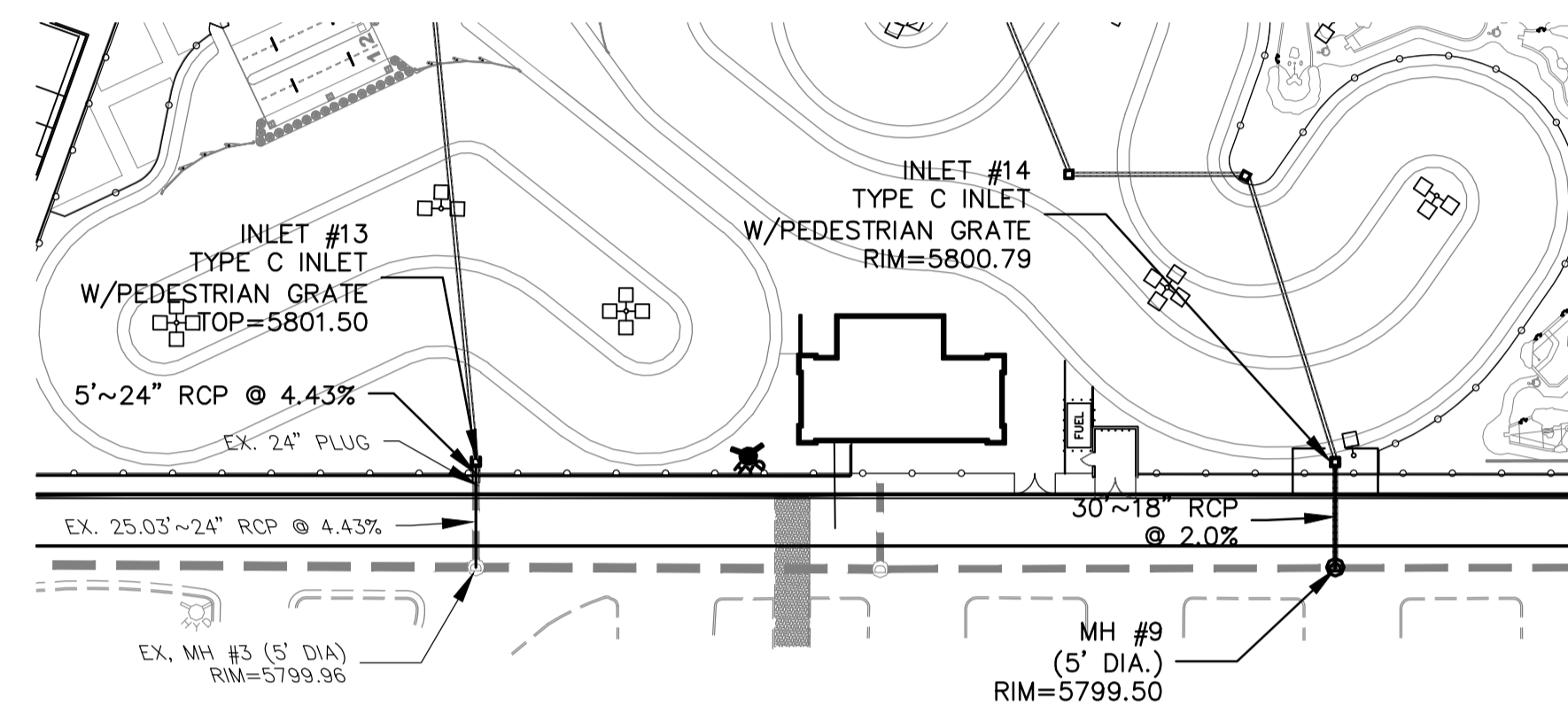
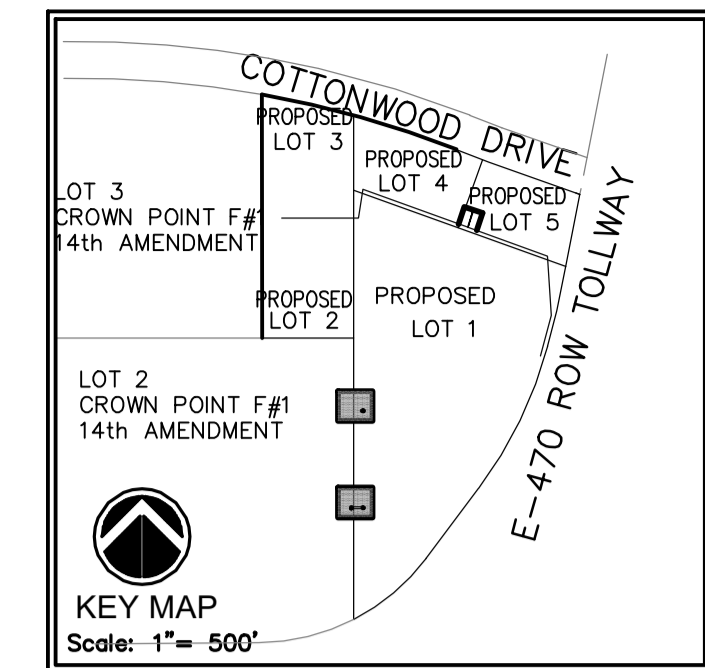

The Town of Parker review constitutes general compliance with the Town's Standards and approved variances, subject to these plans being stamped, signed, and dated by the professional engineer of record. Review by the Town does not constitute approval of the plan design or accuracy and correctness of engineering calculations. Errors in the design or calculations remain the responsibility of the registered professional engineer whose stamp and signature are affixed to this document.

This review does not constitute approval of any private on site improvements which may be shown. Construction cannot commence until all required drainage/traffic report(s), final development plan(s), special review(s), grading permit, and/or other permits are complete, approved and on file with the Town of Parker.

Town of Parker, Public Works Director _____ Date _____
 Town of Parker, Public Works Manager - Stormwater _____ Date _____
 Town of Parker, Public Works Manager - Transportation _____ Date _____

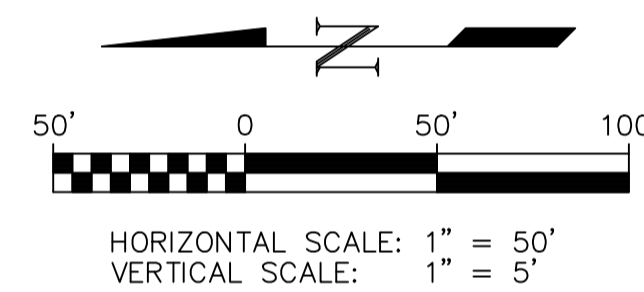

Know what's below.
 Call before you dig.

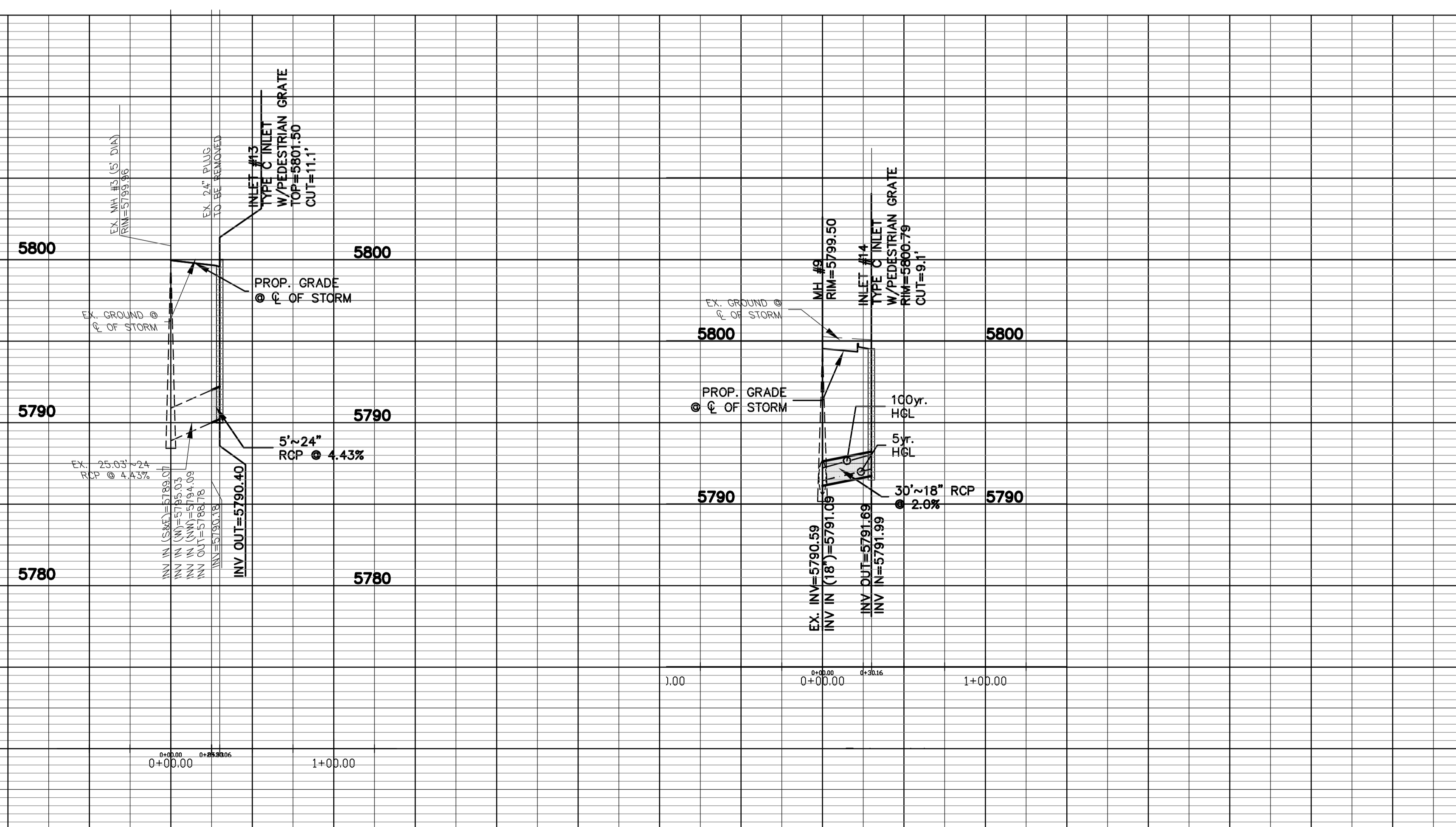

NOTE:
 CONTRACTOR TO FIELD VERIFY EXISTING STORM SEWER ELEVATIONS

REVISION	DATE	MM&D ENGINEERING SERVICES, INC.
COMMENTS	05/26/2015	
		William E. Miller, PE 13389 ENGINEERING
		CONSTRUCTION MANAGEMENT
		9125 N. Clydesdale Road PH (303) 908-0082 Castle Rock, Colorado 80108 FAX (303) 708-8399
		Boondocks Parker, Colorado Storm Plan & Profile Construction Plans
		DATE 09/16/2014 DES/DET/CHK WEM/km PROJ. NO. 13-343 SHEET 18 OF 24

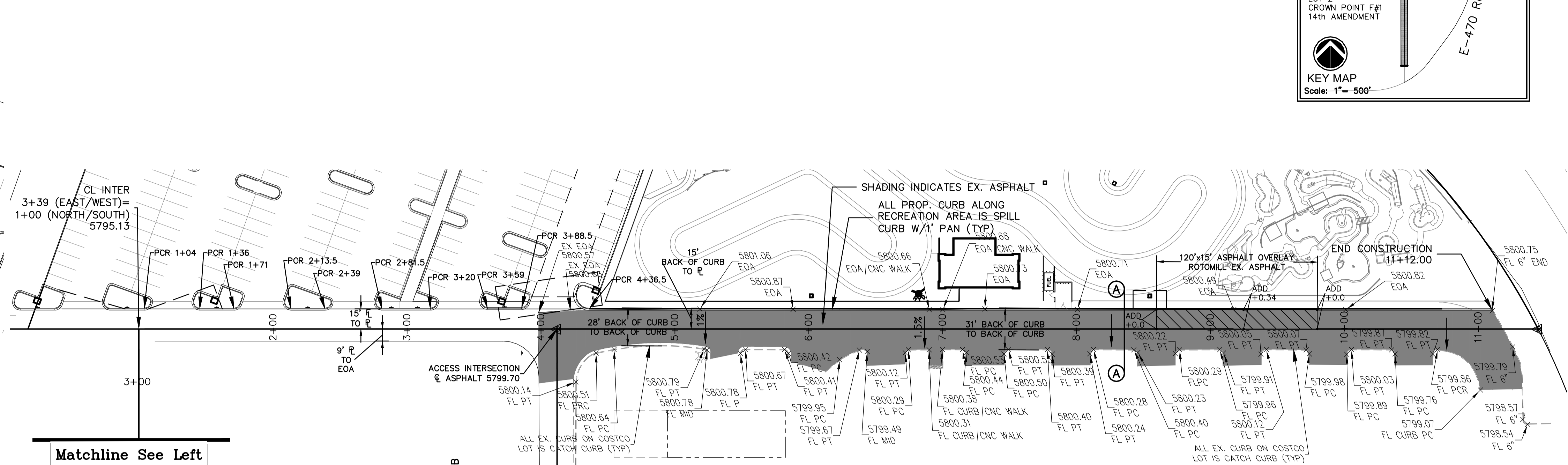
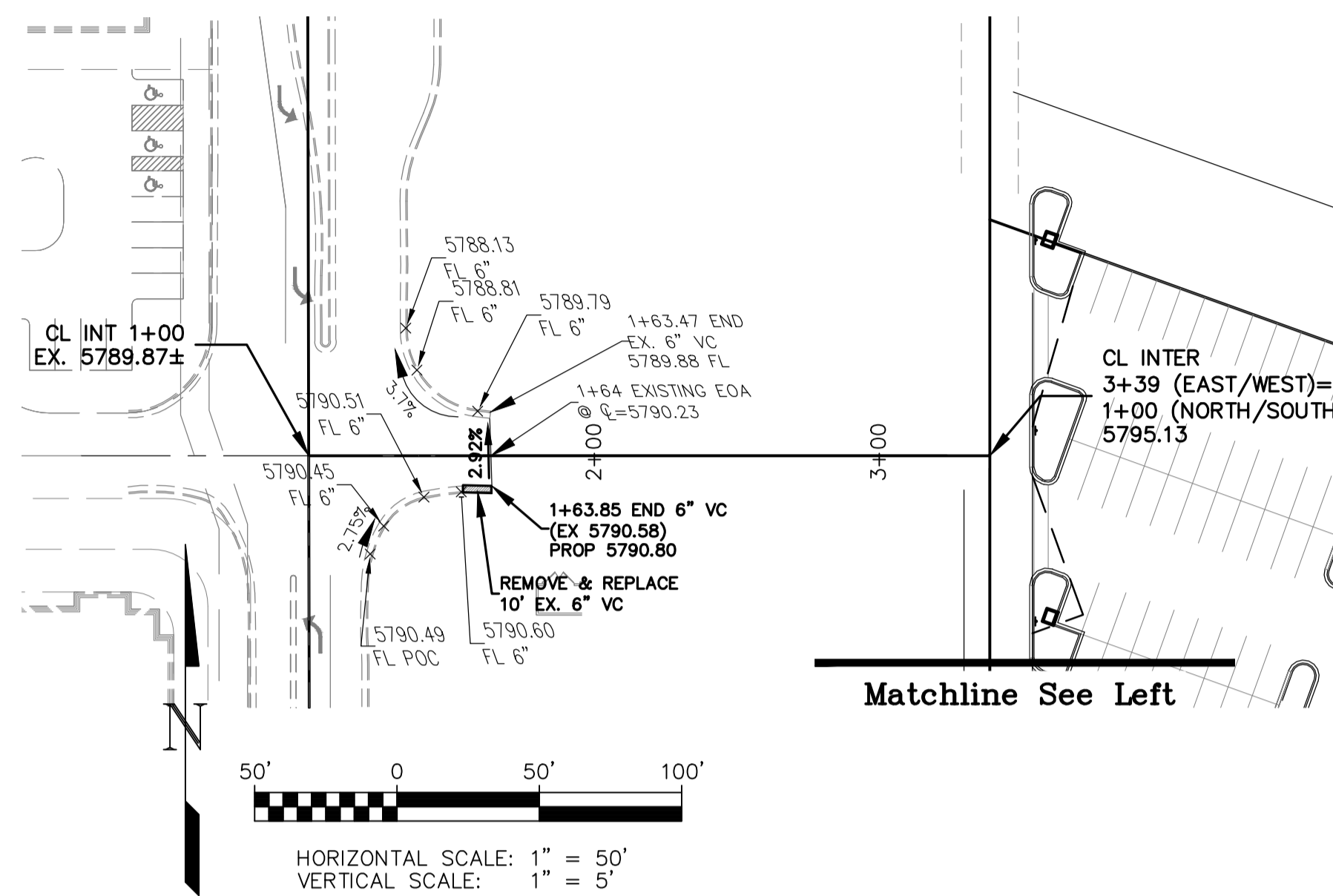
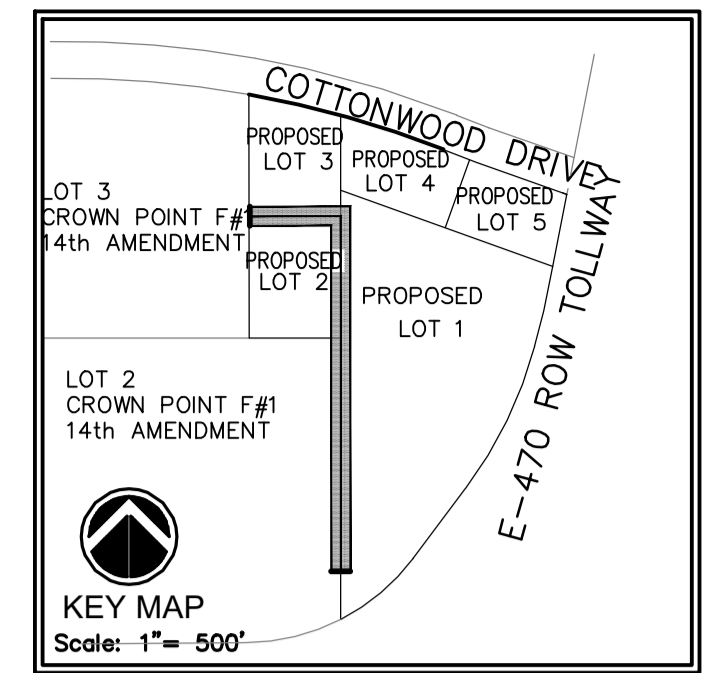

The Town of Parker review constitutes general compliance with the Town's Standards and approved variances, subject to these plans being stamped, signed, and dated by the professional engineer of record. Review by the Town does not constitute approval of the plan design or accuracy and correctness of engineering calculations. Errors in the design or calculations remain the responsibility of the registered professional engineer whose stamp and signature are affixed to this document.

This review does not constitute approval of any private on site improvements which may be shown. Construction cannot commence until all required drainage/traffic report(s), final development plan(s), special review(s), grading permit, and/or other permits are complete, approved and on file with the Town of Parker.

Town of Parker, Public Works Director	Date
Town of Parker, Public Works Manager - Stormwater	Date
Town of Parker, Public Works Manager - Transportation	Date

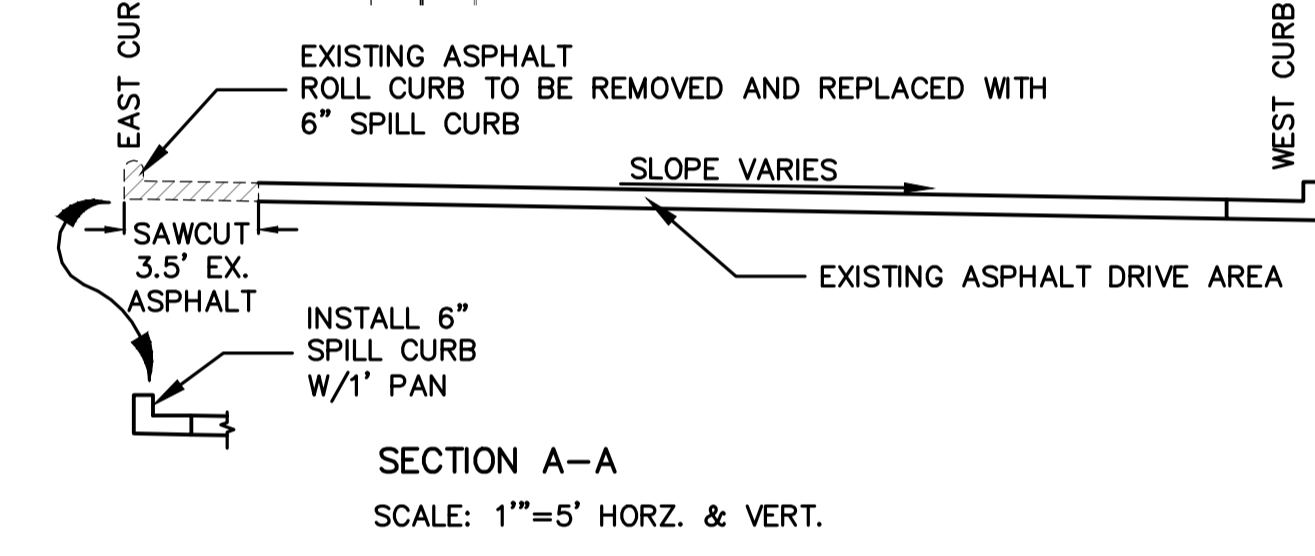

INDICATES EXISTING ASPHALT DRIVE AREA
 INDICATES AREA TO BE ROTOMILLED (DEPTH +0.34')

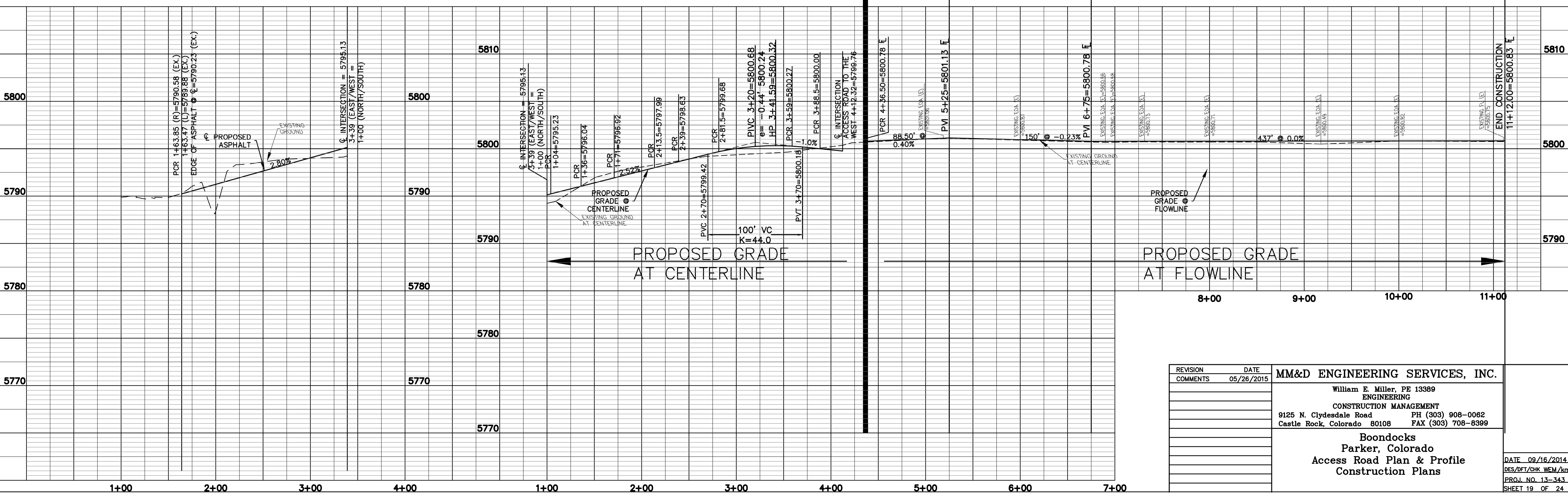
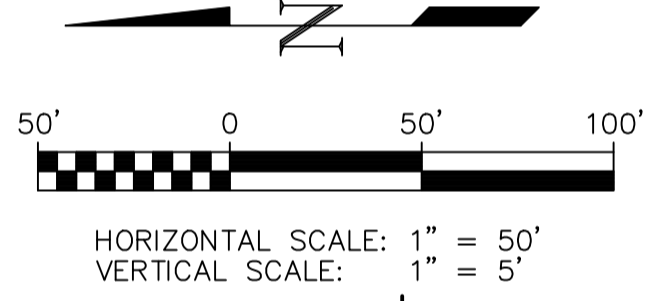

REVISION	DATE	MM&D ENGINEERING SERVICES, INC.
COMMENTS	05/26/2015	
		William E. Miller, PE 13389 ENGINEERING
		CONSTRUCTION MANAGEMENT
		9125 N. Clydesdale Road PH (303) 908-0082 Castle Rock, Colorado 80108 FAX (303) 708-8399
		Boondocks Parker, Colorado Access Road Plan & Profile Construction Plans
		DATE 09/16/2014 DES/DET/CHK WEM/km PROJ. NO. 13-343 SHEET 19 OF 24

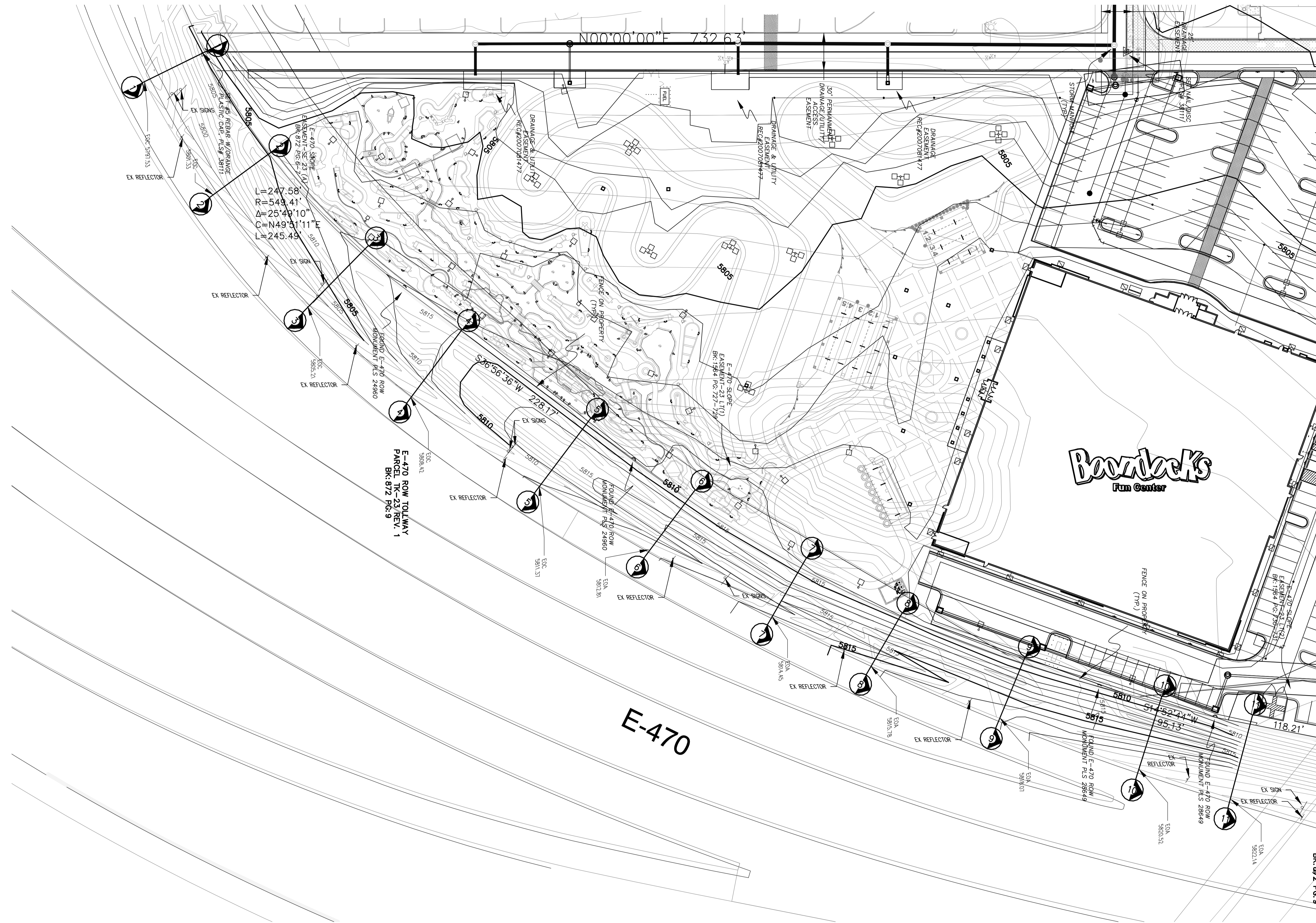

Boondocks
Fun Center

E-470

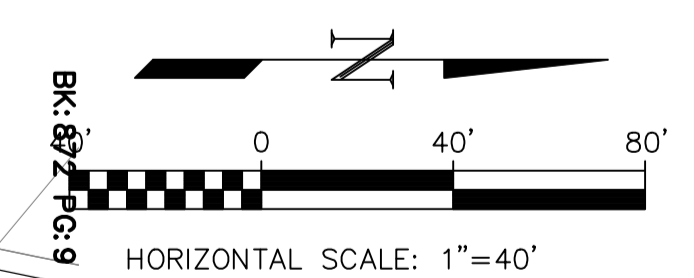

REVISION	DATE	MM&D ENGINEERING SERVICES, INC.
COMMENTS	05/26/2015	William E. Miller, PE 13389 ENGINEERING CONSTRUCTION MANAGEMENT 9125 N. Clydesdale Road PH (303) 908-0082 Castle Rock, Colorado 80108 FAX (303) 708-8399
		Boondocks Parker, Colorado
		Cross Sections at E-470 Plan View Construction Plans
		DATE 09/16/2014 DES/DFI/CHK WEM/km PROJ. NO. 13-343 SHEET 20 OF 24



Know what's below.
Call before you dig.

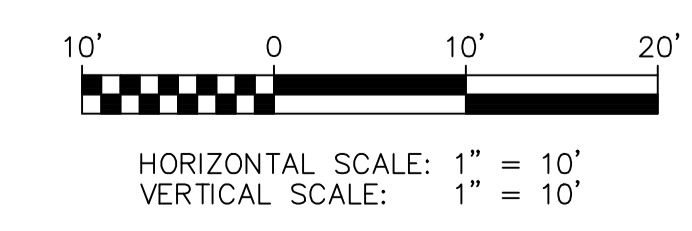
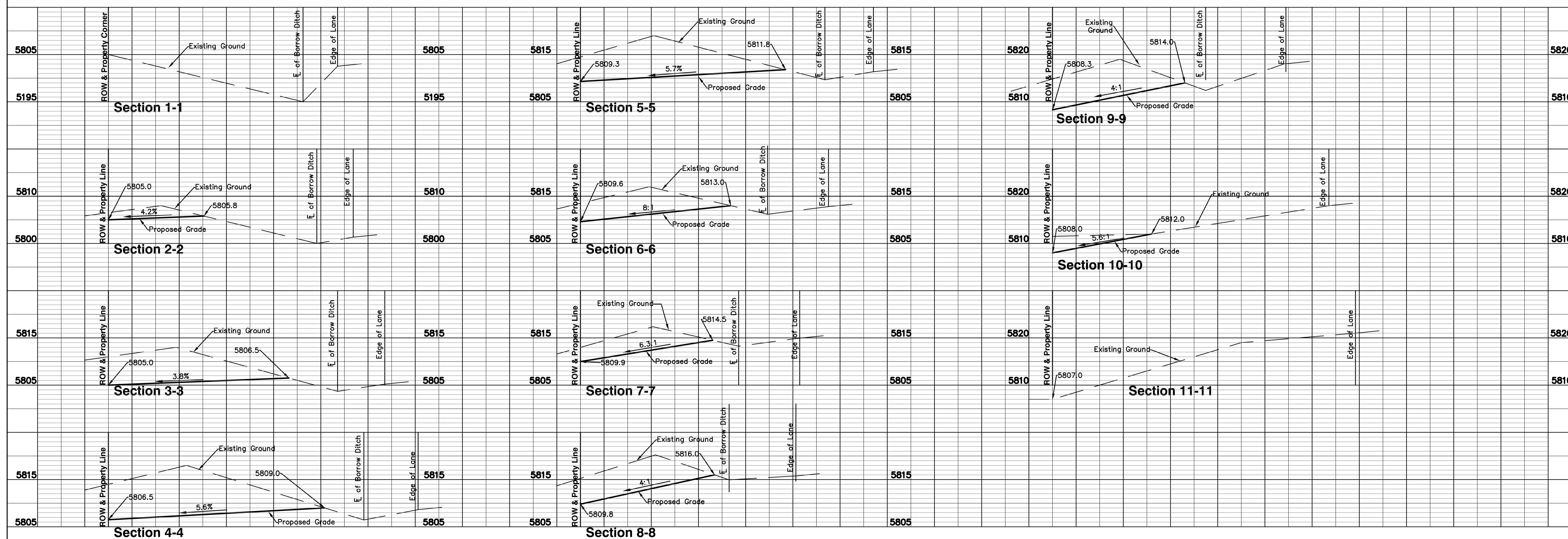

REVISION	DATE	MM&D ENGINEERING SERVICES, INC.
COMMENTS	05/26/2015	
		William E. Miller, PE 13389 ENGINEERING CONSTRUCTION MANAGEMENT 9125 N. Clydesdale Road PH (303) 908-0082 Castle Rock, Colorado 80108 FAX (303) 708-8399
		Boondocks Parker, Colorado Cross Sections at E-470 Profile View Construction Plans
		DATE: 08/16/2014 DES/DET/CHK: WEM/AM PROJ. NO.: 13-343 SHEET 21 OF 24

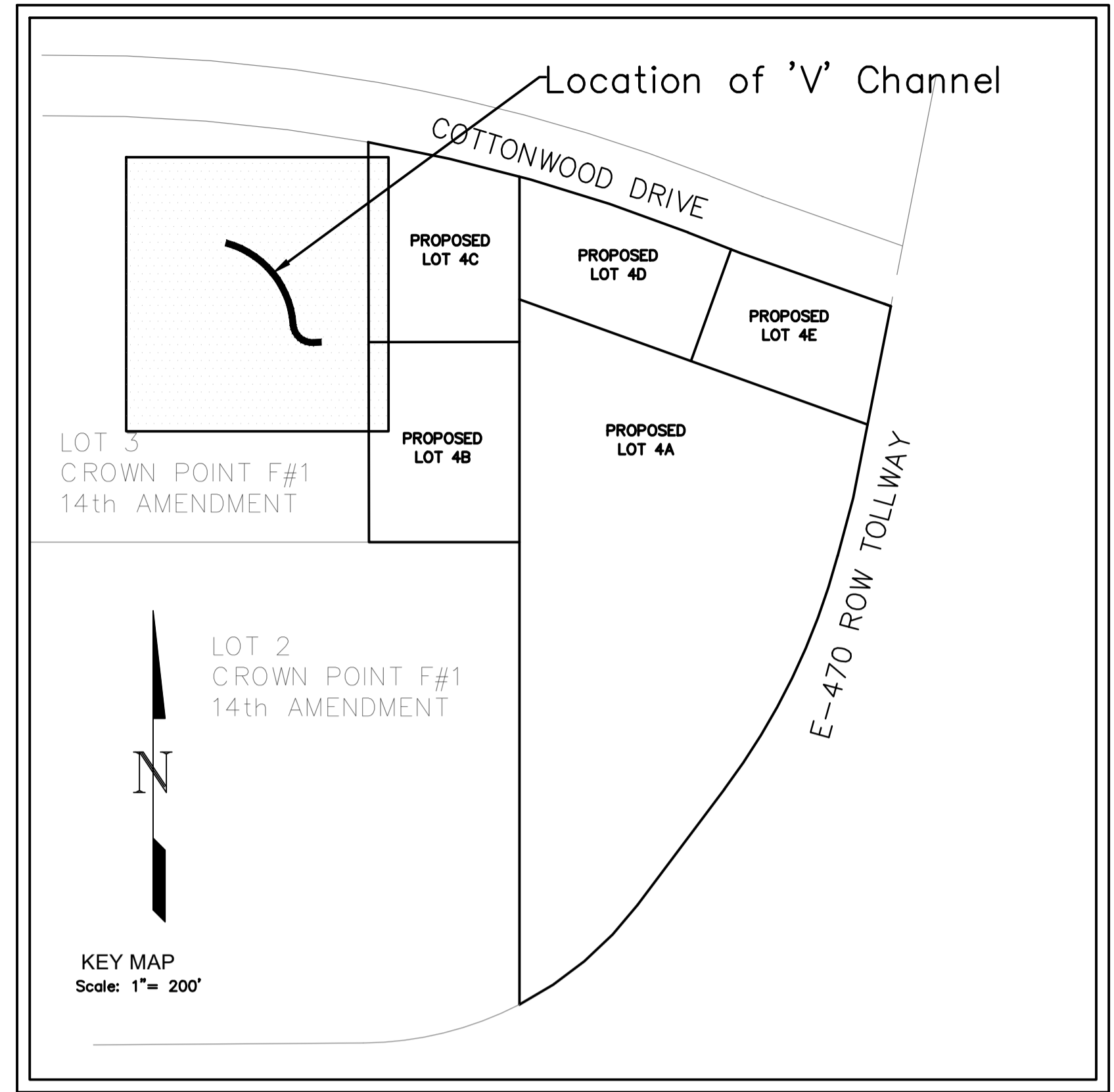
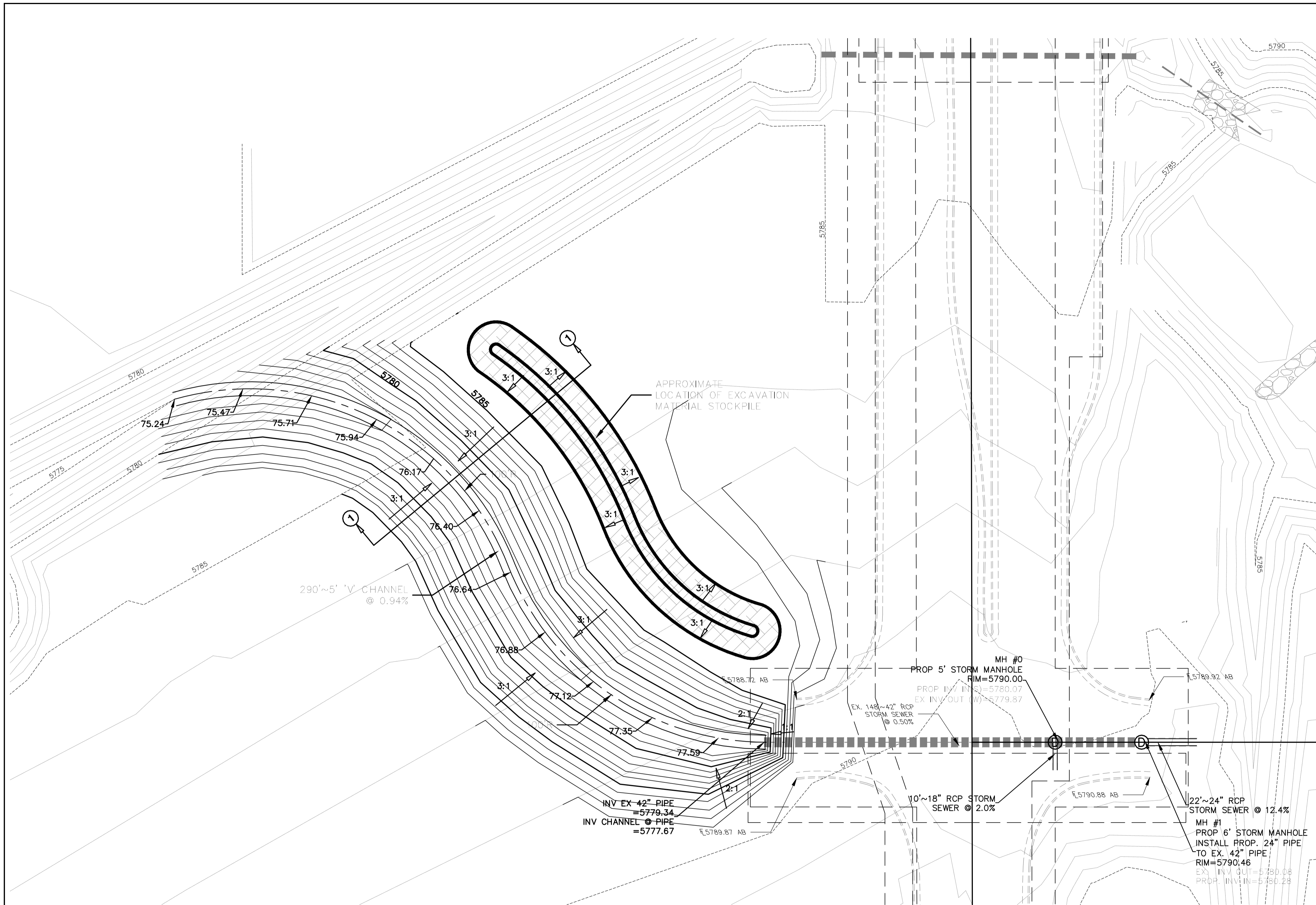

EXISTING PIPE INFORMATION FROM 14TH AMENDMENT, CROWN POINT FILING NO. 1, CONSTRUCTION DOCUMENT ASBULTS, SHEET 15.

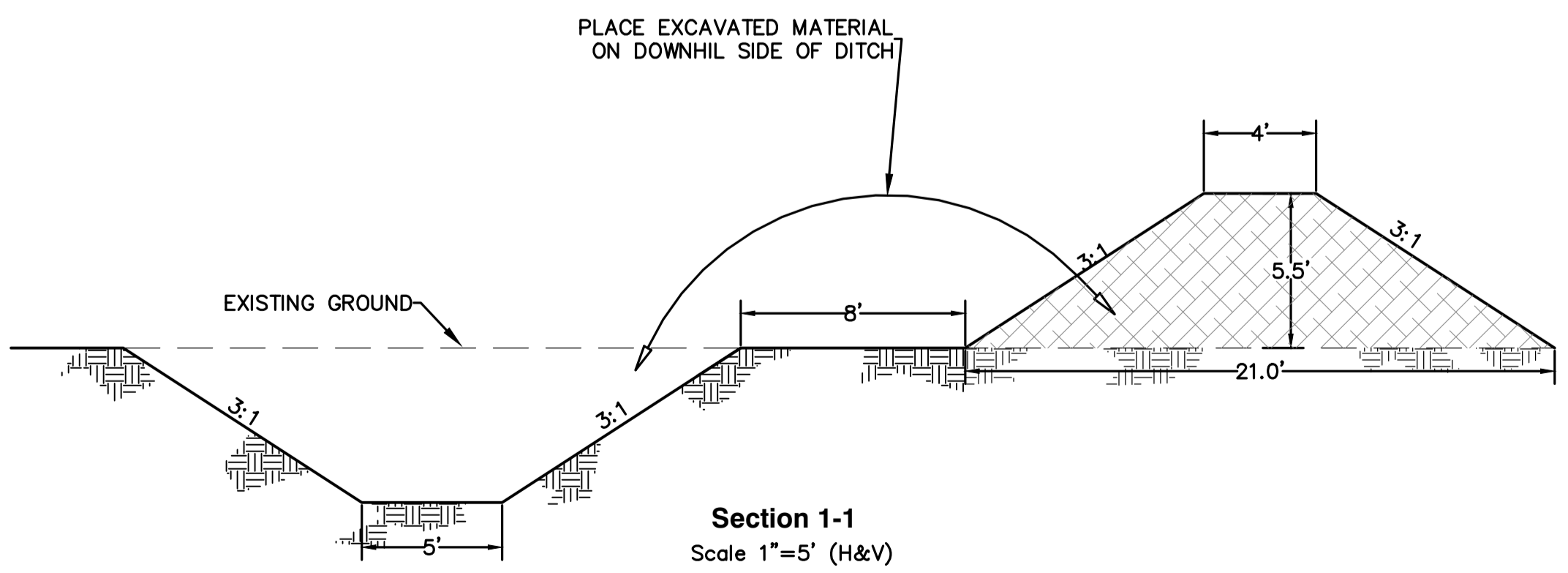
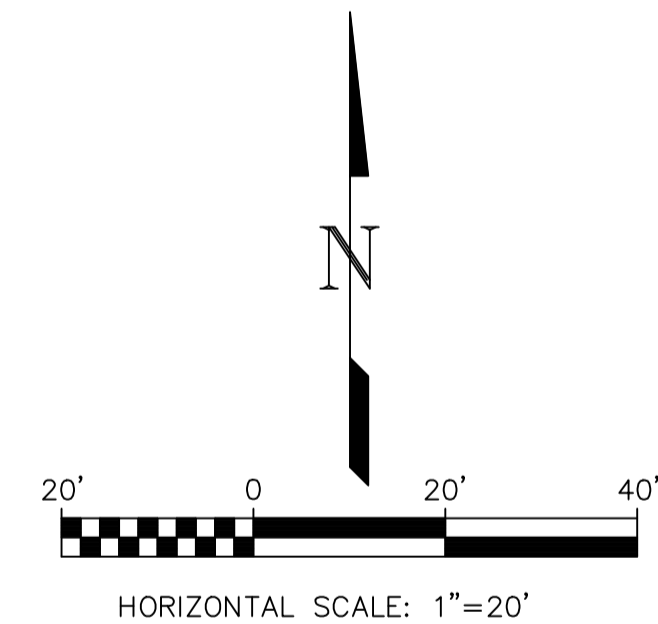

REVISION	DATE	MM&D ENGINEERING SERVICES, INC.
COMMENTS	05/26/2015	
		William E. Miller, PE 13389 ENGINEERING
		CONSTRUCTION MANAGEMENT
		9125 N. Clydesdale Road PH (303) 908-0082 Castle Rock, Colorado 80108 FAX (303) 708-8399
		Boondocks Parker, Colorado
		Off-site 5' Channel Design Construction Plans
		DATE 12/23/2014 DES/DFI/CHK WEM/km PROJ. NO. 13-343 SHEET 22 OF 24

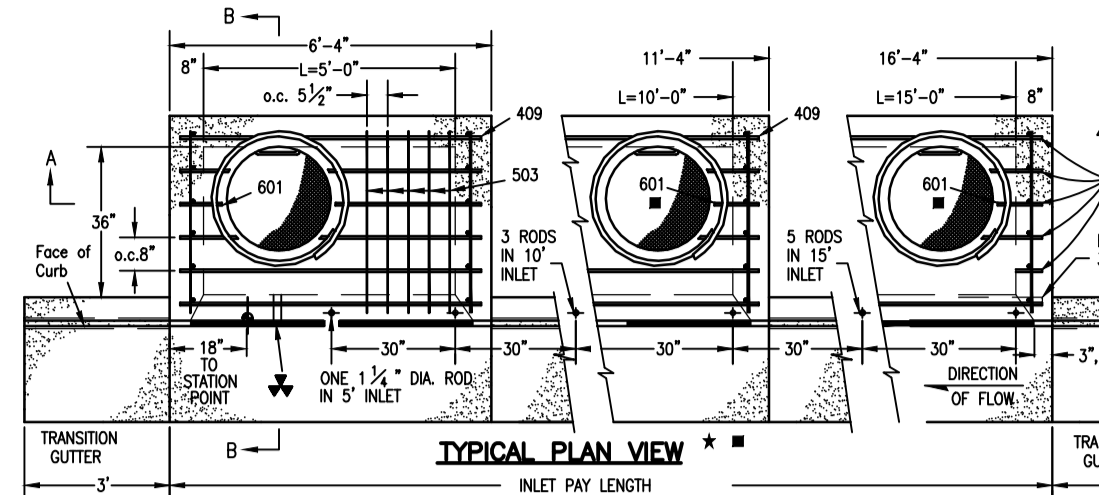

* FOR LENGTH GREATER THAN 5 FT. PROVIDE ACCESS AT BOTH ENDS.
 * ADDITIONAL MANHOLE RING AND COVER REQUIRED WHEN L=10' OR MORE. CUT REINFORCEMENT BAR ACCORDINGLY.
 * MEET SHAPE OF NORMAL BARRIER CURB AND GUTTER HERE.

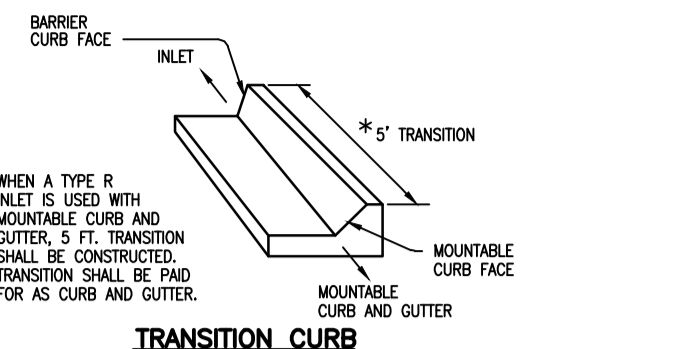

TRANSITION CURB

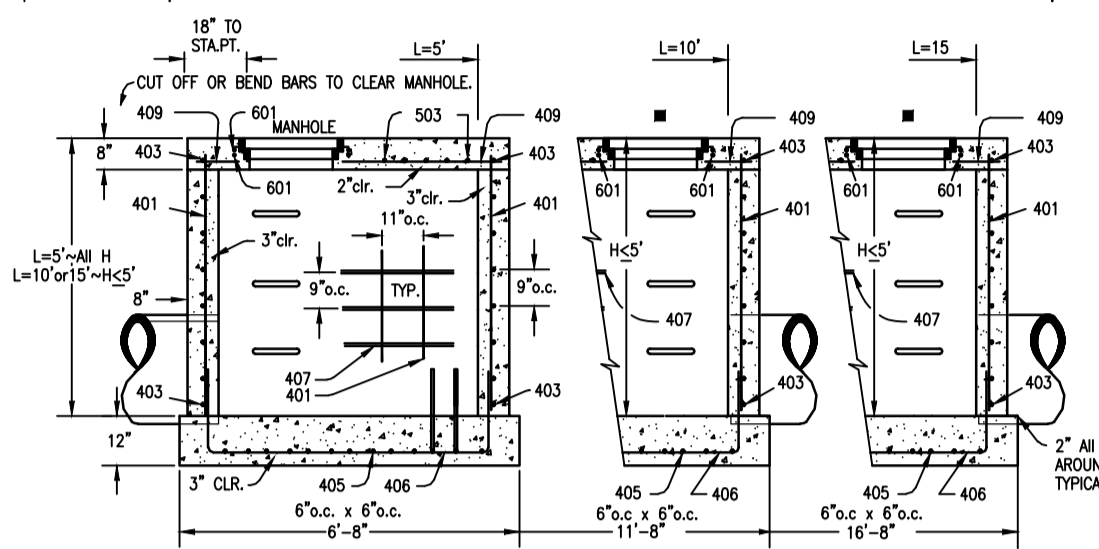

SECTION A-A REGULAR INLET

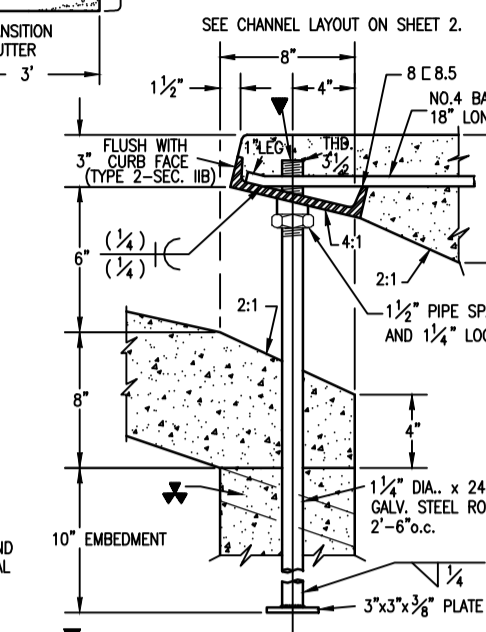

CURB FACE ASSEMBLY

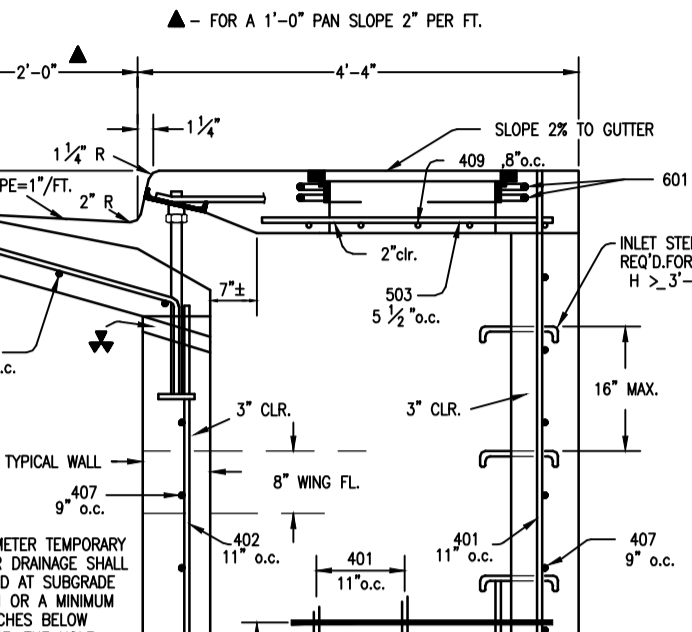

SECTION B-B TYPICAL END VIEW

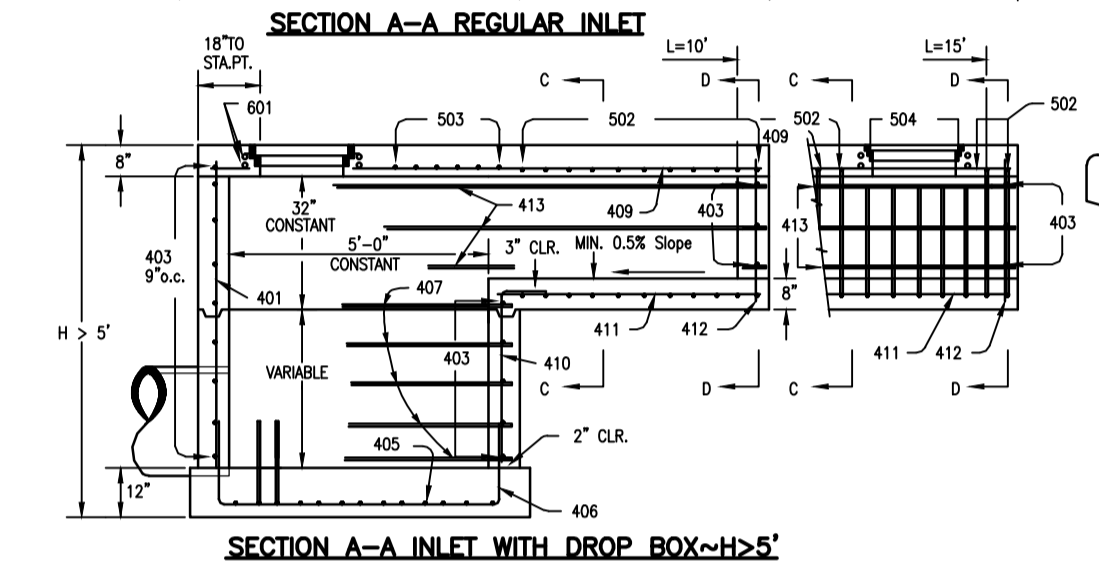

SECTION A-A INLET WITH DROP BOX-H2S'

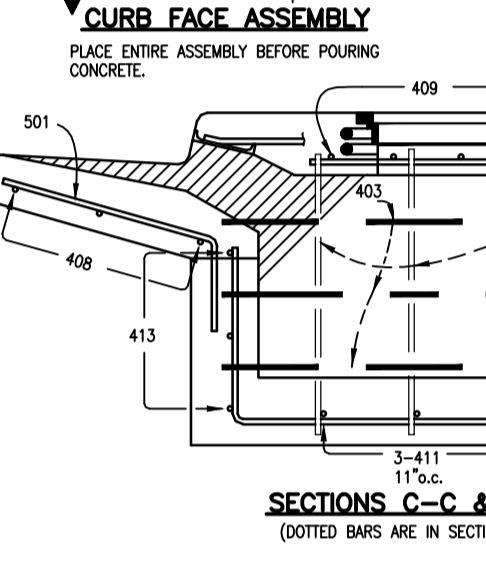

SECTIONS C-C & D-D (DOTTED BARS ARE IN SECTION D-D)

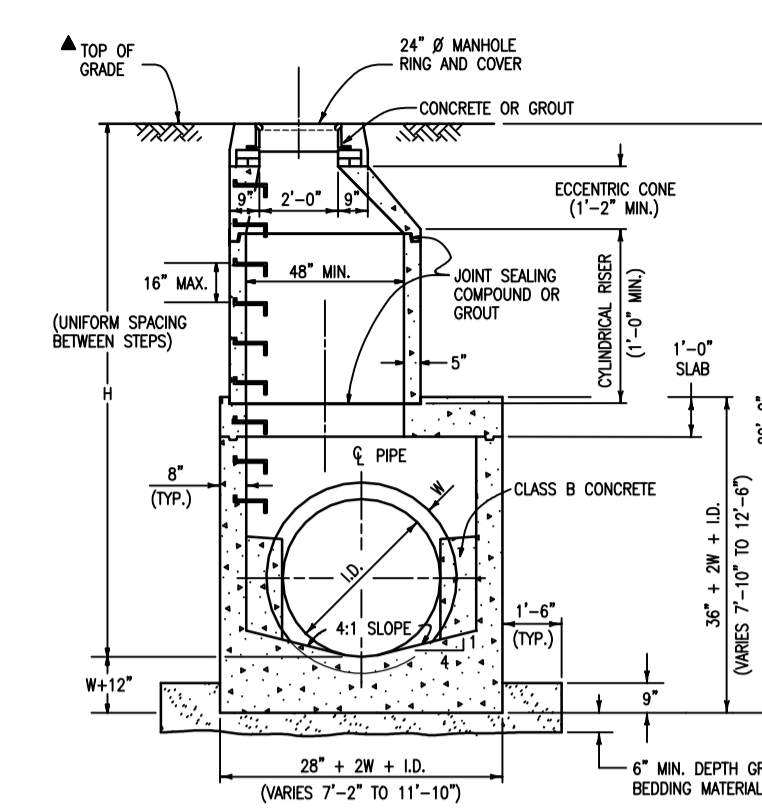

SECTION QUANTITIES FOR CONCRETE MANHOLE BOX BASE

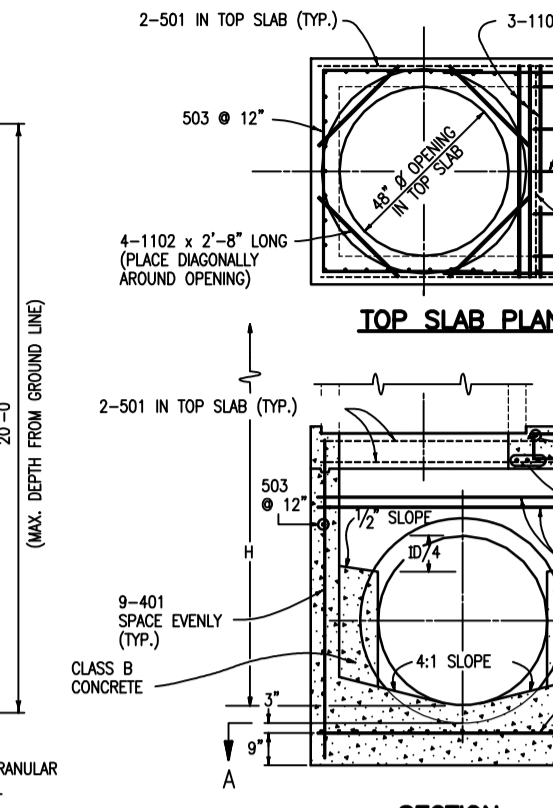

TOP SLAB PLAN

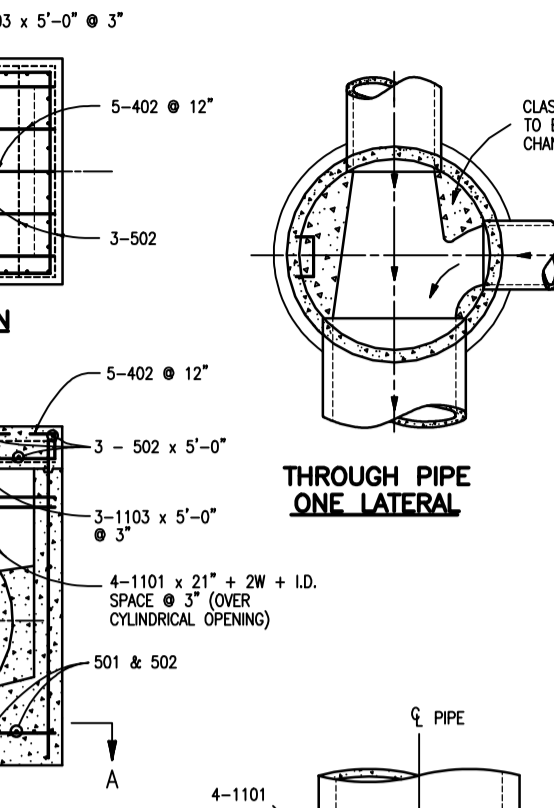

THROUGH PIPE ONE LATERAL

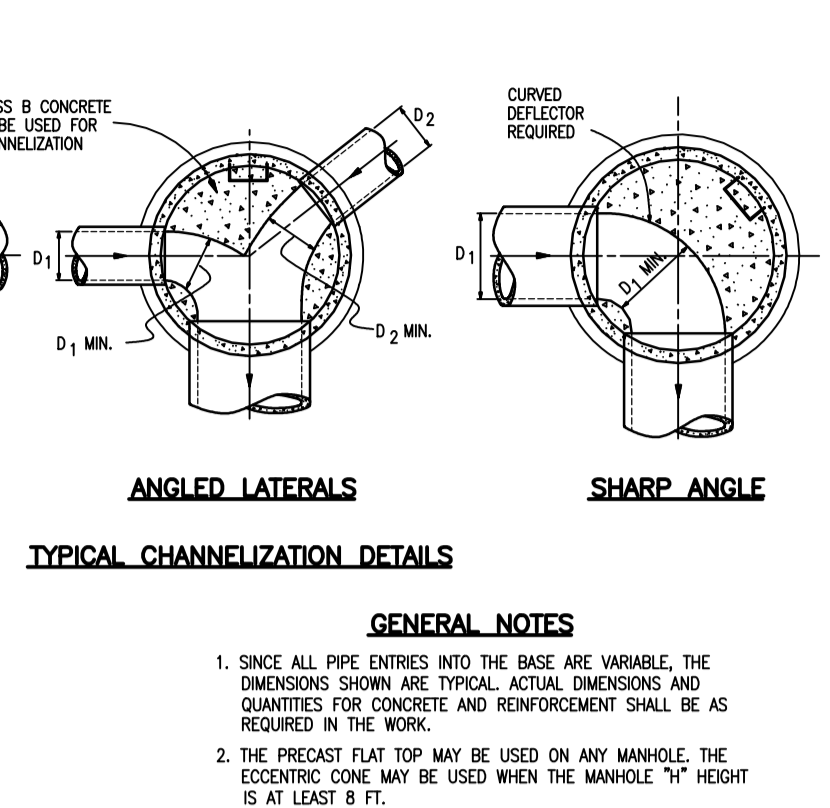

ANGLED LATERALS SHARP ANGLE

MARK	SIZE	TYPE	WT. #/FT.	FORMULAS											
				NO. REQ'D.	LENGTH	NO. REQ'D.	LENGTH	NO. REQ'D.	LENGTH	NO. REQ'D.	LENGTH	NO. REQ'D.	LENGTH		
401	4	I	0.668	18	18	18	18	18	18	18	18	18	18	18	401 BAR LENGTH = 32'+2W+I.D.
402	4	III	0.668	5	5	5	5	5	5	5	5	5	5	402 BAR LENGTH = I.D. + 2W	
501	5	I	1.043	17	17	17	17	17	17	17	17	17	17	501 BAR LENGTH = 24' + I.D. + 2W	
502	5	I	1.043	22	22	22	22	22	22	22	22	22	22	502 NUMBER BARS REQ'D. = 3 + (24+I.D.+2W+I)	
503	5	II	1.043	18	18	18	18	18	18	18	18	18	18	503 NUMBER BARS REQ'D. = 2 + (33+I.D.+2W+I)	
504	5	I	1.043	12	12	12	12	12	12	12	12	12	12	504 NUMBER BARS REQ'D. = 2 + (24+I.D.+2W+I)	
1101	11	I	5.313	4	4	4	4	4	4	4	4	4	4	1101 BAR LENGTH = 21' + I.D. + 2W	
1102	11	I	5.313	2	2	2	2	2	2	2	2	2	2	1102 BAR LENGTH = 21' + I.D. + 2W	
1103	11	I	5.313	5	5	5	5	5	5	5	5	5	5	1103 BAR LENGTH = 21' + I.D. + 2W	
REINFORCING STEEL TOTAL				965.6	1237.5	1272.2	1204.0	1380.2	1303.4	1303.4	1303.4	1303.4	1303.4	1303.4	
CONCRETE - CUBIC YARDS - TOTAL				6.0	6.6	7.3	8.0	9.5	11.1	11.1	11.1	11.1	11.1	11.1	

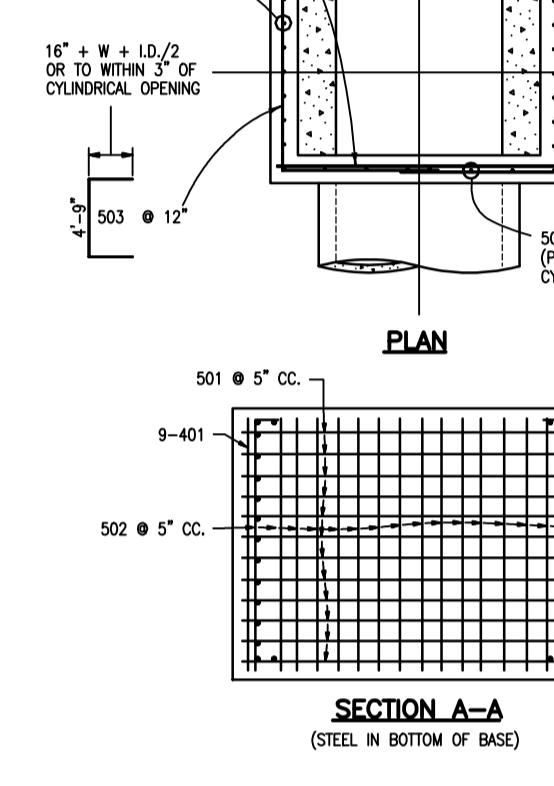

SECTION A-A (STEEL IN BOTTOM OF BASE)

TABLE ONE ~ BAR LIST FOR CURB INLETS, TYPE "R"

MARK	DIA. IN.	O.C. SPACING	TYPE	ALL INLETS, H = 5'			INLETS, H = 5'		
				L=5'	L=10'	L=15'	L=5'	L=10'	L=15'
401	1 1/2"	11"	II	15	21	26	11	7	11
402	1 1/2"	11"	II	7	13	18	7	7	7
403	9"	11"	II	4	4	4	4	4	4
405	6"	VI	II	11	6	10	11	6	10
406	6"	VIII	II	7	13	10	7	8	10
407	9"	II	II	5	10	10	5	10	10
408	12"	II	II	3	11	10	3	16	10
409	8"	VI	II	6	10	10	6	10	10
410	1 1/2"	VI	II	3	3	3	3	3	3
411	1 1/2"	VI	II	3	5	2	3	10	2
412	1 1/2"	VI	II	3	2	9	3	2	9
413	9"	VI	II	7	10	10	7	15	10
501	5 1/2"	IV	II	11	3	4	22	3	4
502	5 1/2"	III	II	11	11	5	11	11	5
503	5 1/2"	II	II	5	3	6	27	3	6
504	5 1/2"	IX	II	5	8	4	5	8	4
601	2 1/2"	V	II	2	8	10	2	8	10

TABLE TWO ~ BARS AND QUANTITIES VARIABLE WITH "H"

H'	LENGTH	REGULAR INLETS		DROPPED INLETS	
		NO. REQ'D.	WT. (LBS.)	NO. REQ'D.	WT. (LBS.)
3'-0"	2'-8"	10	7	3.2	285
3'-6"	3'-2"	10	7	3.4	305
4'-0"	3'-8"	12	9	3.7	326
4'-6"	4'-2"	12	9	3.9	334
5'-0"	4'-8"	14	11	4.1	354
5'-6"	5'-2"	16	13	4.4	375
6'-0"	5'-8"	16	13	4.6	382
6'-6"	6'-2"	18	15	4.8	402
7'-0"	6'-8"	20	17	5.0	423
7'-6"	7'-2"	20	17	5.3	430
8'-0"	7'-8"	22	19	5.5	451
8'-6"	8'-2"	24	21	5.7	471
9'-0"	8'-8"	24	21	6.0	479
9'-6"	9'-2"	26	23	6.2	499
10'-0"	9'-8"	28	25	6.4	520
10'-6"	10'-2"	28	25	6.7	527
11'-0"	10'-8"	30	27	6.9	547

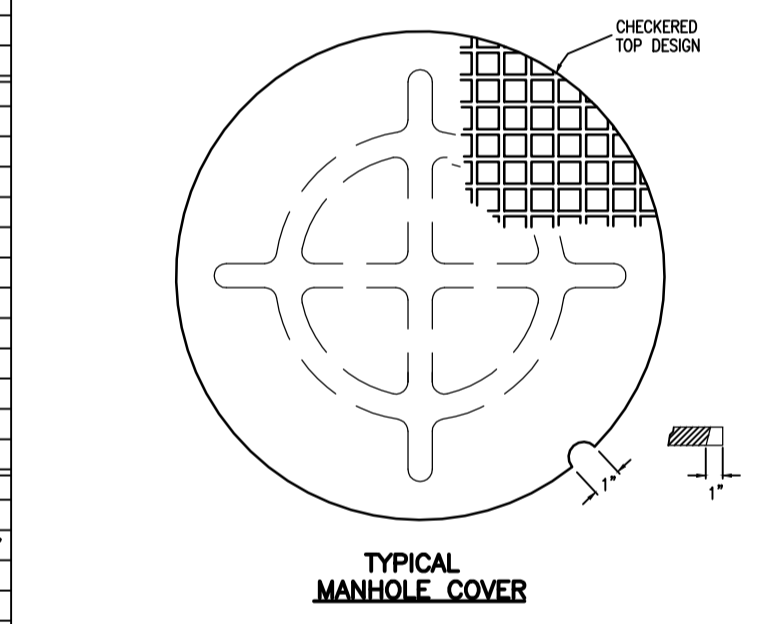

TYPICAL MANHOLE COVER

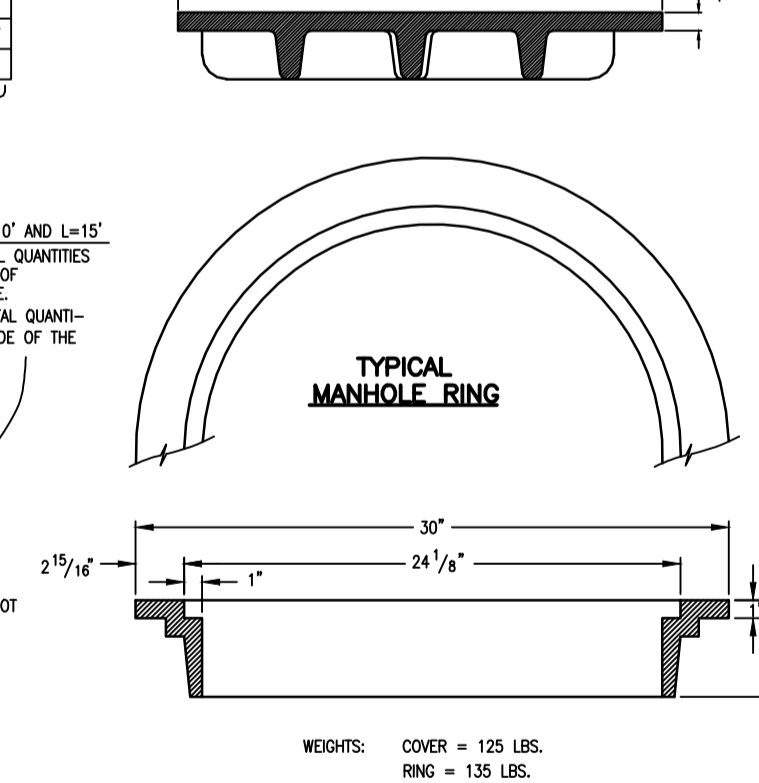

TYPICAL MANHOLE RING

- GENERAL NOTES
- ALL CONCRETE SHALL BE CLASS B.
 - CONCRETE WALLS SHALL BE FORMED ON BOTH SIDES AND SHALL BE 8 IN. THICK.
 - INLET STEPS SHALL BE IN ACCORDANCE WITH AASHTO M 199.
 - CURB FACE ASSEMBLY SHALL BE GALVANIZED AFTER WELDING.
 - EXPOSED CONCRETE CORNERS SHALL BE CHAMFERED 3/4 IN. CURB AND GUTTER CORNERS SHALL BE FINISHED TO MATCH THE EXISTING CURB AND GUTTER BEYOND THE TRANSITION GUTTER.
 - REINFORCING BARS SHALL BE DEFORMED AND SHALL HAVE A 2 IN. MINIMUM CLEARANCE. ALL REINFORCING BARS SHALL BE EPOXY COATED.
 - DIMENSIONS AND WEIGHTS OF TYPICAL MANHOLE RING AND COVER ARE NOMINAL.
 - MATERIAL FOR MANHOLE RINGS AND COVERS SHALL BE GRAY OR DUCTILE CAST IRON CONFORMING TO 712.06.
 - SINCE PIPE ENTRIES INTO THE INLET ARE VARIABLE, THE DIMENSIONS SHOWN ARE TYPICAL. ACTUAL DIMENSIONS AND QUANTITIES FOR CONCRETE AND REINFORCEMENT SHALL BE AS REQUIRED IN THE WORK. QUANTITIES INCLUDE VOLUMES OCCUPIED BY PIPES.
 - STRUCTURAL STEEL SHALL BE GALVANIZED AND SHALL CONFORM TO THE REQUIREMENTS OF 712.06.

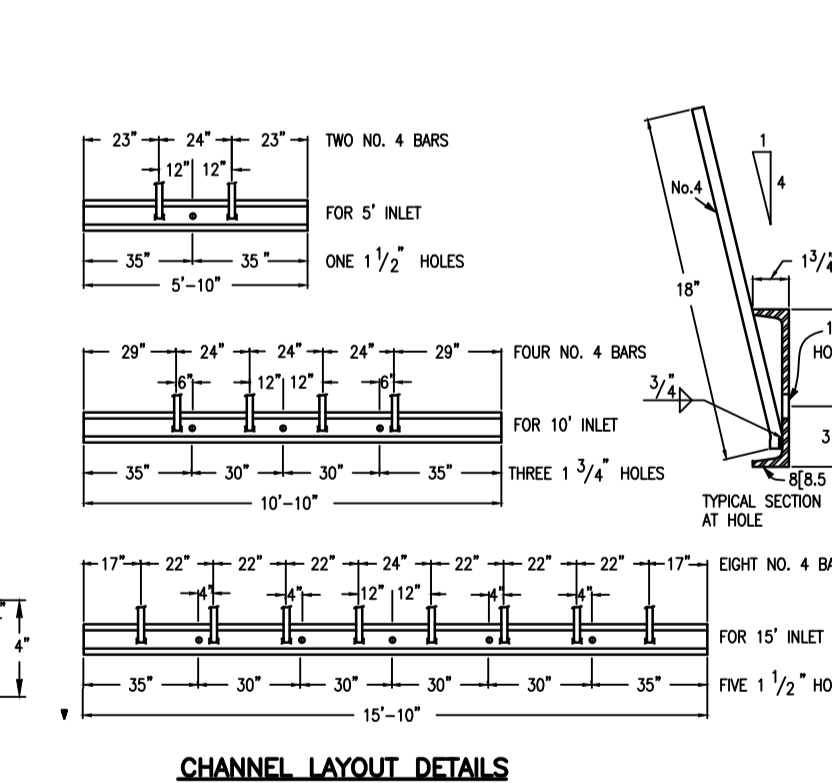

CHANNEL LAYOUT DETAILS

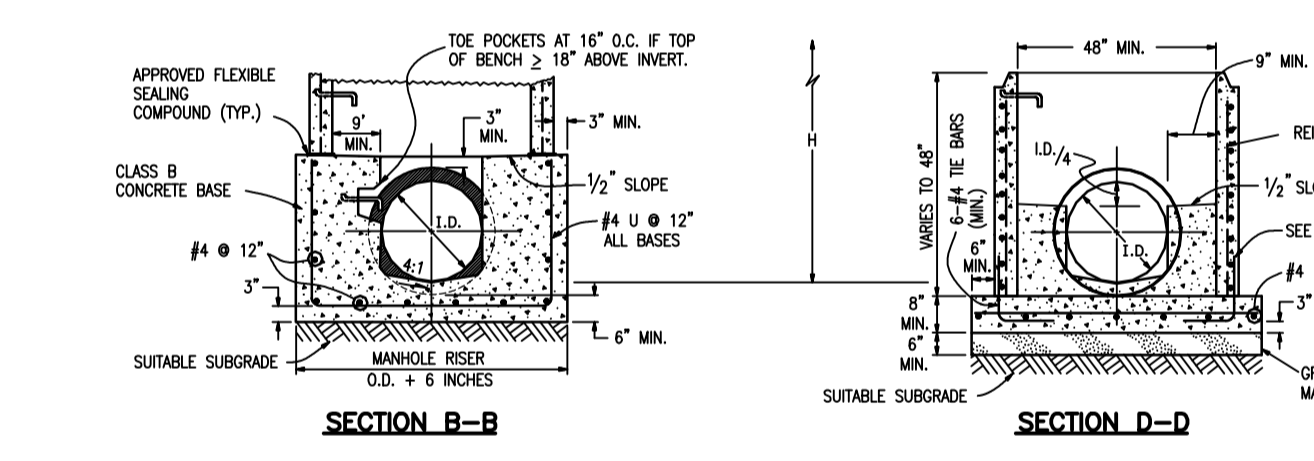

SECTION B-B SECTION D-D

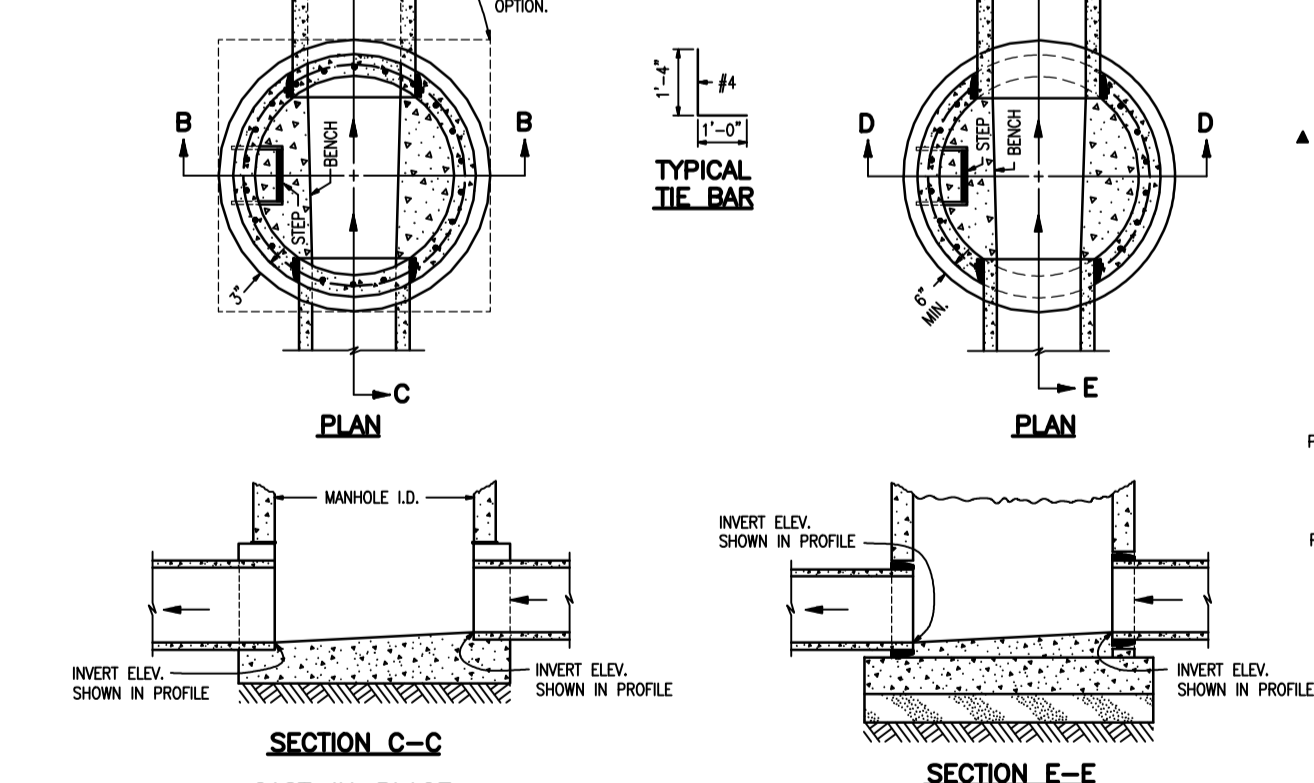

SECTION C-C SECTION E-E

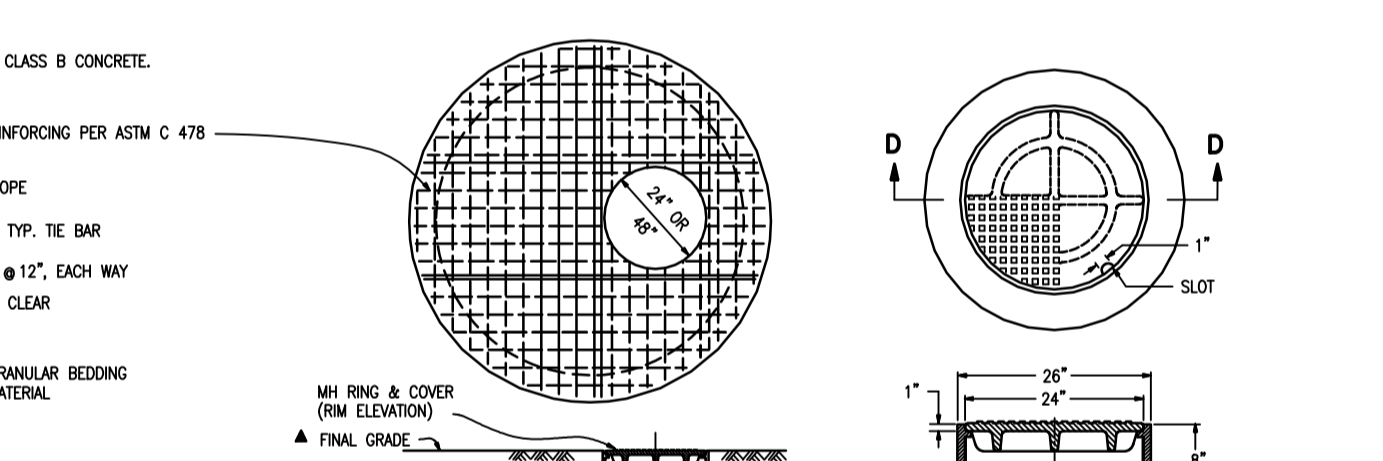

FLAT TOP SECTION DETAIL

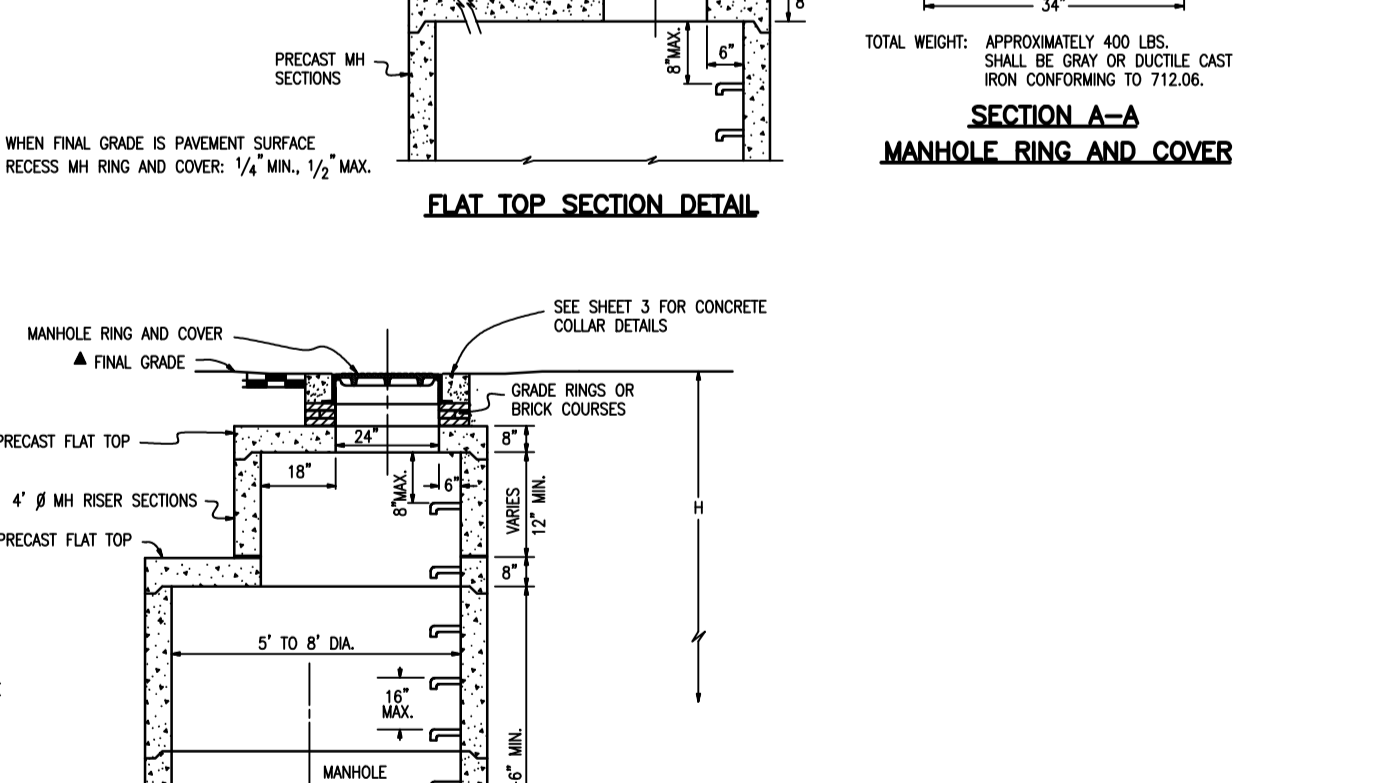

MANHOLE SLAB BASE

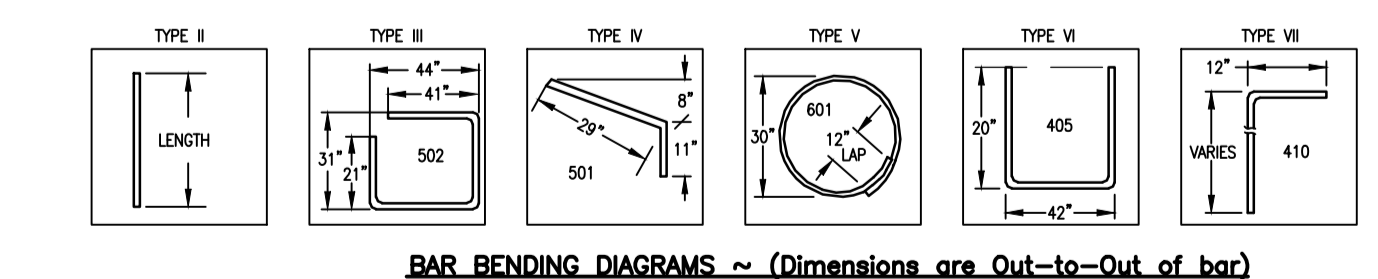

BAR BENDING DIAGRAMS ~ (Dimensions are Out-to-Out of Bar)

- PRECAST MANHOLE BASES:
- THE BASE SLAB SHALL BE POURED MONOLITHICALLY WITH BOTTOM RISER SECTION.
 - PRECAST MANHOLE BASES SHALL FIT THE CONDITIONS AND LOCATIONS FOR WHICH THEY ARE INTENDED WITHOUT ANY FIELD MODIFICATIONS. ANY MANHOLE BASE WHICH REQUIRES FIELD CUTTING OR MODIFICATION IN ORDER TO FIT THE LOCATIONS INTENDED WILL BE REJECTED BY THE OWNER AND REMOVED AND REPLACED BY THE CONTRACTOR AT NO COST TO THE DEPARTMENT.
 - PRECAST MANHOLE BASES SHALL BE BEDDED ON AN APPROVED GRANULAR BEDDING MATERIAL AS SHOWN ABOVE.



REVISION	DATE	MM&D ENGINEERING SERVICES, INC.
COMMENTS	05/26/2015	William E. Miller, PE 13389 ENGINEERING CONSTRUCTION MANAGEMENT 8125 N. Clydesdale Road PH (303) 908-0082 Castle Rock, Colorado 80108 FAX (303) 708-8399
Boondocks Parker, Colorado Detail Sheet Construction Plans		

submittal 03/10/2015
 DATE 09/16/2014
 DES/DET/CHK. WEM/km
 PROJ. NO. 13-343
 SHEET 24 OF 24