



Town of Parker Community Development Department
Development Review Division
Attention: **Ryan McGee**

Application Type: **Site Plan**
Status: **First Referral**
Application Name: **Parker Auto Plaza F1 B3 L1**
Case/AP#: **SP17-007**
Referral Received: September 7, 2017
Comments Due: October 5, 2017

Application Location: 12405 S Parker Road

Review date: **September 27, 2017**
Plan reviewer: **Randall L. Capra**, rcapra@parkeronline.org
Phone: 303.805.3168

Narrative: This request is a site plan for two multitenant retail buildings and grading and utilities for future commercial buildings on a 15.95 acre lot in Parker Auto Plaza Filing 1 located at the southwest corner of Parker Road and Pine Drive. The combined square footage of both buildings will total approximately 13,000 sf.; both buildings are to be fully sprinklered per the appropriate edition of NFPA 13.

Code Reference: 2015 International Fire Code, 2015 International Building Code

UNRESOLVED ISSUES/COMMENTS

1. A sidewalk shall be provided to each riser room and a 4x4 pad shall be provided at the location of the FDC as applicable.
2. The applicant shall provide an auto turn analysis indicating that apparatus can navigate all portions of this site (both sides of the gas canopy); NO PARKING – FIRE LANE signage is required for any portion of the access where the 20 foot clear width requirement cannot be met.
3. The Town of Parker requires that fire apparatus access roads meet the clear-width and weight-bearing standards of the jurisdiction in which the project is located. Roadways shall be designed to support the imposed weight of fire apparatus, 24 ton two axle and 30 ton three axle vehicles. An unimpeded clear width of 20 feet shall be maintained at all times. As such, any location where parked vehicles would obstruct this clear width requirement will require “NO PARKING – FIRE LANE” signage. This signage shall be red on white.

GENERAL COMMENTS (as applicable)

All engineering documents submitted to the Town of Parker shall bear the wet signature and seal of the engineer or architect in responsible charge of the design.

Water distribution and site access components shall be installed and in service prior to the construction of any portion of the structure, except by special permit issued by the Fire District.

Underground fire lines

When thrust blocks are used as part of the pipe restraint system, submitted plans for permit shall provide detailed documentation that the thrust blocks satisfy all requirements of 13 NFPA 24: 10.8.2, including specific thrust block dimensions and mathematical calculations for block dimensions per guidelines provided in Annex A.10.8.2.

FIRE ACCESS ROAD DESIGN CRITERIA

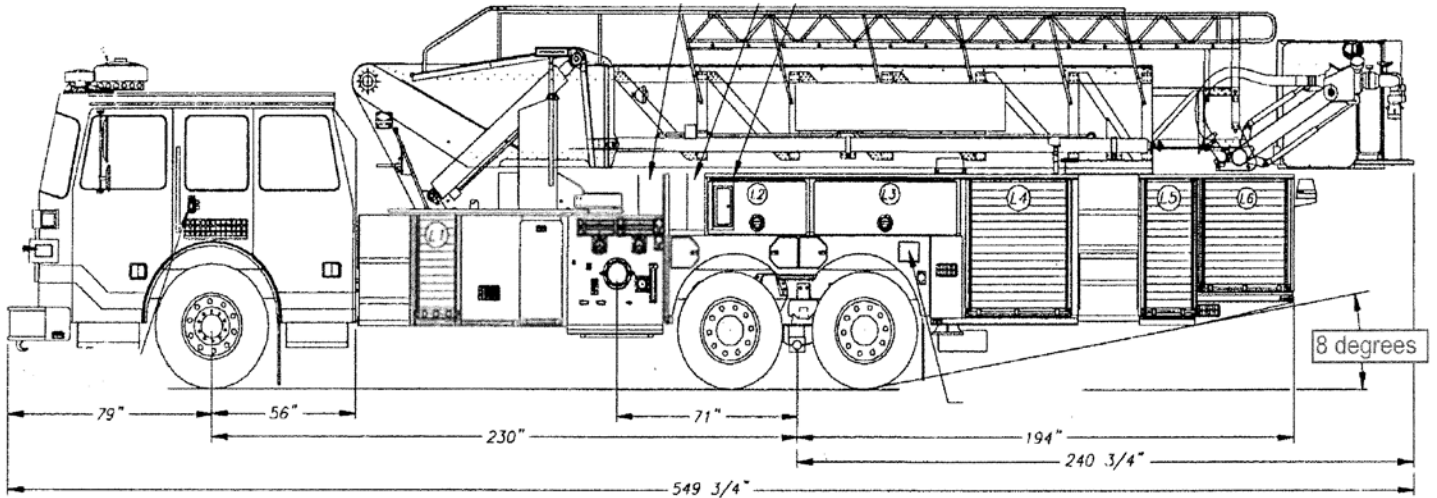

Vehicles specifications

Length = 47.5'

Width = 10' 1" mirror to mirror

Height = 11' 6" [a minimum unobstructed vertical clearance of 13' 6" is required] 06, 09 IFC 503.2.1

Inside Turning Radius = 27 feet

Outside Turning Radius = 45 feet

Access Roads

Width unobstructed: 20 feet minimum [15 IFC 503.2.1]

Grade: 6% maximum within 150 feet of structures. Grades for other roads shall not exceed that of the appropriate county or municipal roadway standard. [15 IFC 503.2.7]

Design load: 72,000 pounds [15 IFC 503.2.3]

Surface: All-weather material of asphalt or concrete

FIRE CODE REVIEW BLOCK

All fire hydrants shall be installed according to water utility standards. The number and locations of the fire hydrants as shown on the Overall Utility Plan are correct as specified by the Town of Parker, Community Development Department.

Fire Code Official or Designated Representative

Date

(NOTE – Underground Fire Line (UFL) submittal documents must meet the requirements of NFPA 24 when submitting for review.)

Underground Fire Line - Submittal Requirements

Reference: 2013 NFPA 24 [Installation of Private Fire Service Mains and Their Appurtenances](#)

A separate permit is required and will be issued pending review of a detailed submittal which must include the following:
[15 IFC 901.2]

4.1.1 Working plans shall be submitted for approval to the authority having jurisdiction before any equipment is installed or replaced.

4.1.2 Deviation from approved plans shall require permission of the authority having jurisdiction.

4.1.3 Working plans shall be drawn to an indicated scale on sheets of uniform size, with a plan of each floor as applicable, and shall include the following items that pertain to the design of the system:

- (1) Name of owner
- (2) Location, including street address
- (3) Point of compass
- (4) A graphic representation of the scale used on all plans
- (5) Name and address of contractor
- (6) Size and location of all water supplies
- (7) The following items that pertain to private fire service mains:
 - (a) Size
 - (b) Length
 - (c) Location
 - (d) Material (ductile-iron, PVC., etc.)
 - (e) Point of connection to city main
 - (f) Sizes, types, and locations of valves, depth at which the top of the pipe is laid below grade
 - (g) Method of restraint (Meg-a-Lug or similar)

4.1.4 The working plan submittal shall include the manufacturer's installation instructions for any specially listed equipment, including descriptions, applications, and limitations for any devices, piping, or fittings. Submittals must include installation specifications for thrust blocks, corrosion protection, restraint system, bedding, detail of pipe under the building up to, and including, the flange. When it is intended that a different contractor will extend the fire line from a stopping point outside the building, to the inside flange, a second submittal and permit is required.

All tees, plugs, reducers, valves, and hydrant branches shall be restrained against movement by thrust blocks [10.8.2] or restrained joint systems [10.8.3]. When thrust blocks are used as part of the pipe restraint system, submitted plans shall provide detailed documentation that the thrust blocks satisfy all requirements of Section 10.8.2, including specific thrust block dimensions and mathematical calculations for block dimensions per guidelines provided in Annex A.10.8.2.

Any individual or company who physically works on or installs any part of a fire suppression system, including underground supply lines, from public water lines to system risers and backflow preventers, **must** be registered with the Colorado Division of Fire Safety. [Dept of Public Safety, Division of Fire Safety, Fire Suppression Program 8 CCR 1507-11:3.1.2]
Documentation of valid annual registration may be required with plan submittal.

The following website for the Colorado Division of Fire Safety will provide registration instructions.

<http://dfs.state.co.us/SuppAppsProclnsp.htm>

All submittals must display a wet stamp and original signature by a Colorado licensed professional engineer or NICET III, or higher, in fire suppression systems. [Dept of Public Safety, Division of Fire Safety, Fire Suppression Program 8 CCR 1507