

HORSESHOE RIDGE SUBDIVISION 1ST AMENDMENT

LOT 2, BLOCK 1, HORSESHOE RIDGE SUBDIVISION 1ST AMENDMENT

A PARCEL OF LAND LOCATED IN THE SE 1/4 OF SECTION 28, TOWNSHIP 6 SOUTH, RANGE 66 WEST OF THE 6TH PRINCIPAL MERIDIAN

PARKER WATER AND SANITATION DISTRICT

LEGAL DESCRIPTION

LOT 2, BLOCK 1, HORSESHOE RIDGE SUBDIVISION 1ST AMENDMENT

A PARCEL OF LAND LOCATED IN THE SE 1/4 OF SECTION 28, TOWNSHIP 6 SOUTH, RANGE 66 WEST OF THE 6TH PRINCIPAL MERIDIAN

CONTAINING 41,493 SF (0.953 AC), MORE OR LESS.

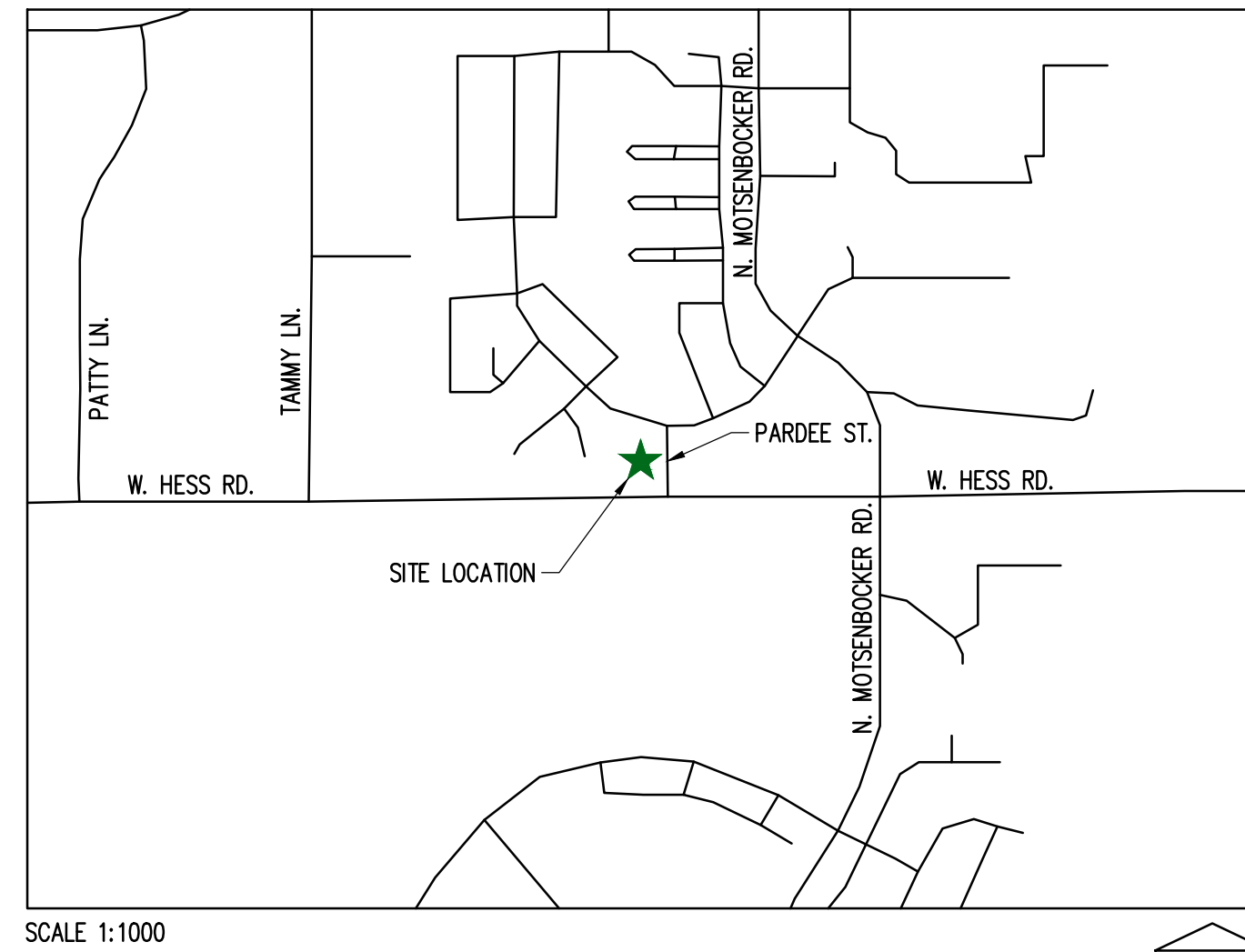

VICINITY MAP

SHEET INDEX

CV-1.0	COVER SHEET
ON-1.0	WATER & SANITARY GENERAL NOTES
C-3.0	OVERALL UTILITY PLAN
C-4.0	WATER AND SANITARY DETAILS
C-4.1	WATER AND SANITARY DETAILS

PROJECT CONTACTS:

PROPERTY OWNER
 BRYTAR COMPANIES
 8117 PRESTON ROAD, #300
 DALLAS, TX 75225
 (214) 632-4860
 CONTACT: SCOTT REMPHREY

APPLICANT
 BRYTAR COMPANIES
 8117 PRESTON ROAD, #300
 DALLAS, TX 75225
 (214) 632-4860
 CONTACT: SCOTT REMPHREY

CIVIL ENGINEER
 RIDGETOP ENGINEERING AND CONSULTING, LLC
 541 E. GARDEN DRIVE, UNIT N
 WINDSOR, CO 80550
 (970) 663-4552
 CONTACT: MIKE BEACH, P.E.

ARCHITECT
 ROGUE ARCHITECTURE
 4100 WADSWORTH BLVD, SUITE 300
 WHEAT RIDGE, CO 80033
 (720) 599-3330
 CONTACT: SCOTT BODUCH

SURVEYOR
 PLS GROUP
 532 WEST 66TH STREET
 LOVELAND, CO 80538
 (970) 669-2100
 CONTACT: BRYAN SHORT

PARKER PUBLIC WORKS
 ASSOCIATE PLANNER
 20120 E. MAIN STREET
 PARKER, CO 80138
 (303) 805-3199
 CONTACT: STACEY NERGER

GAS
 XCEL ENERGY
 180 LARIMER ST.
 DENVER, CO 80202
 (800) 895-2999

SOUTH METRO FIRE RESCUE AUTHORITY
 9195 E. MINERAL AVE.
 CENTENNIAL, CO 80112
 (720) 488-7200
 CONTACT: RANDY CAPRA

INTERNATIONAL RURAL ELECTRIC ASSOC.
 5496 NORTH US HWY 85
 P.O. BOX DRAWER A
 SEDALIA, CO 80135
 (303) 688-3100
 CONTACT: BROOK KAUFMAN

PARKER WATER AND SANITATION DISTRICT
 18100 E WOODMAN DR
 PARKER, CO 80134
 (303) 841-4627

MATERIALS LIST

DESCRIPTION	QTY.	UNIT
TAPPING SADDLE CONNECTION	1	EACH
1.5" TYPE K COPPER	133	LF
1.5" METER ASSEMBLY	1	EACH
6" DUCTILE IRON PIPE	145	LF
8"x6" TEE CONNECTION	1	EACH
90° TEE BLOCK	1	EACH
6" PVC (SANITARY)	112	LF
SANITARY CLEANOUT	4	EACH
GREASE INTERCEPTOR	1	EACH
SAMPLE MANHOLE	1	EACH

SOUTH METRO FIRE PROTECTION DISTRICT

ALL FIRE HYDRANTS SHALL BE INSTALLED ACCORDING TO DISTRICT STANDARDS. THE NUMBER AND LOCATIONS OF THE FIRE HYDRANTS AS SHOWN ON THE OVERALL UTILITY PLAN ARE CORRECT AS SPECIFIED BY THE SOUTH METRO FIRE PROTECTION DISTRICT

 (SIGNATURE OF FIRE CHIEF OR DESIGNATED REPRESENTATIVE)

 DATE SIGNED

PWSD CERTIFICATION

THE DISTRICT INSPECTOR MUST BE NOTIFIED AT LEAST 48 HOURS PRIOR TO START OF CONSTRUCTION. CALL PARKER WATER AND SANITATION DISTRICT AT 303-841-4627. THE DISTRICT WILL PROVIDE PERIODIC INSPECTIONS OF THE WORK. 24 HOUR NOTICE TO THE INSPECTOR IS REQUIRED FOR SCHEDULING INSPECTIONS. ANY WORK ACCOMPLISHED WITHOUT THE APPROVAL OF THE INSPECTOR WILL BE SUBJECT TO REJECTION. REVIEWED FOR CONFORMANCE TO PARKER WATER AND SANITATION DISTRICT STANDARDS.

BY: _____
 (DISTRICT REPRESENTATIVE)

 DATED SIGNED

APPROVED FOR CONSTRUCTION
 PARKER WATER AND SANITATION DISTRICT

BY: _____
 (DISTRICT ENGINEER)

 DATED SIGNED

LOGO



SEAL

PROJECT TITLE

RETAIL

LOT 2, BLOCK 1
 HORSESHOE RIDGE
 PARKER, CO 80134

PREPARED FOR

BRYTAR
 COMPANIES

8117 PRESTON RD. #300
 DALLAS, TX 75225

SUBMITTAL

PWSD

DRAWN BY: BSA

CHECKED BY: MRB

PROJECT NO.: 18-075-001

REVISIONS

2ND SUBMITTAL 10/31/2019

DATE

5/28/2019

SHEET TITLE

COVER SHEET

SHEET INFORMATION

CV-1

HORSESHOE RIDGE SUBDIVISION 1ST AMENDMENT

LOT 2, BLOCK 1, HORSESHOE RIDGE SUBDIVISION 1ST AMENDMENT

A PARCEL OF LAND LOCATED IN THE SE 1/4 OF SECTION 28, TOWNSHIP 6 SOUTH, RANGE 66 WEST OF THE 6TH PRINCIPAL MERIDIAN

PARKER WATER AND SANITATION DISTRICT



541 E. Garden Drive, Windsor, CO 80550
T (878) 683-4552 W ridgepeng.com

SEAL

PROJECT TITLE

RETAIL

PREPARED FOR

BRYTAR COMPANIES

LOT 2, BLOCK 1
HORSESHOE RIDGE
PARKER, CO 80134

8117 PRESTON RD. #300
DALLAS, TX 75225

SUBMITTAL

PWSD

DRAWN BY:	BSA
CHECKED BY:	MRB
PROJECT NO.:	18-075-001

REVISIONS

2ND SUBMITTAL	10/31/2019

DATE

5/28/2019

SHEET TITLE

WATER & SANITARY GENERAL NOTES

SHEET INFORMATION

CN-1.0

2 of 5

PWSD GENERAL NOTES

1. ALL MATERIALS AND WORKMANSHIP SHALL BE IN CONFORMANCE WITH THE PWSD ENGINEERING STANDARDS AND SPECIFICATIONS, LATEST VERSION.
2. THE CONTRACTOR SHALL CONTACT ALL APPROPRIATE UTILITY COMPANIES AND THE TOWN OF PARKER, DOUGLAS COUNTY AND OTHER NEIGHBORING CITIES AND TOWNS PRIOR TO THE BEGINNING OF ANY CONSTRUCTION. CONTRACTOR SHALL BE RESPONSIBLE FOR LOCATING ANY EXISTING UTILITY (INCLUDING DEPTHS) WHICH MAY CONFLICT WITH THE PROPOSED CONSTRUCTION. ALL EXISTING UTILITIES SHALL BE PROTECTED FROM DAMAGE BY THE CONTRACTOR. DAMAGED UTILITIES SHALL BE REPAIRED BY THE CONTRACTOR AT HIS OWN EXPENSE.
3. ALL ITEMS SHOWN ON THE PLANS AS EXISTING ARE SHOWN IN APPROXIMATE LOCATIONS ONLY. THE ACTUAL LOCATIONS MAY VARY FROM THE PLANS, ESPECIALLY IN THE CASE OF UNDERGROUND UTILITIES. WHENEVER THE CONTRACTOR DISCOVERS A DISCREPANCY IN LOCATIONS CONTACT THE PWSD IMMEDIATELY.
4. PWSD ENGINEER AND OTHER APPROVING AGENCIES ARE TO BE NOTIFIED 48 HOURS PRIOR TO CONSTRUCTION.
5. THE CONTRACTOR SHALL OBTAIN, AT HIS EXPENSE, ALL PERMITS NECESSARY TO PERFORM THE PROPOSED WORK.
6. ALL CONCRETE SHALL BE A MINIMUM OF CLASS A, 6 SACK, TYPE II, 3000-POUND COMPRESSION STRENGTH.
7. THE DESIGN ENGINEER SHALL SUBMIT ONE (1) SET OF "AS-BUILT" DRAWINGS AND ELECTRONIC FILES TO THE DISTRICT ENGINEER FOR APPROVAL BY DISTRICT. AFTER APPROVAL HAS BEEN GRANTED BY THE DISTRICT ENGINEER, FULL SIZE PRINTS SHALL BE TRANSMITTED TO THE PWSD OFFICE.
8. NO WORK SHALL BE BACKFILLED UNTIL THE CONSTRUCTION HAS BEEN INSPECTED AND APPROVED FOR BACKFILLING BY THE DISTRICT ENGINEER OR REPRESENTATIVE OF THE DISTRICT ENGINEER. ALL BACKFILL MATERIAL SHALL BE COMPACTED TO 95% STANDARD PROCTOR DENSITY. COMPACTION TESTS MUST BE SUBMITTED TO DISTRICT ENGINEER PRIOR TO PROBATIONARY ACCEPTANCE.
9. TRENCHES SHALL BE EXCAVATED AND THE PIPE EXPOSED FOR THE INSPECTION AT ANY LOCATION ON THE PROJECT IF SO ORDERED BY THE INSPECTOR.
10. THE CONTRACTOR WILL BE HELD RESPONSIBLE FOR THE PROPER FUNCTIONING OF LINES (WATER AND SEWER) FOR UP TO TWO (2) YEARS FROM THE DATE OF PROBATIONARY ACCEPTANCE OF THE LINES BY THE DISTRICT. ANY MALFUNCTION DURING THIS PERIOD OF GUARANTEE SHALL BE REMEDIED BY THE CONTRACTOR TO THE SATISFACTION OF THE DISTRICT ENGINEER AT NO EXPENSE TO THE DISTRICT.
11. SURFACE GRADES ARE TO BE WITHIN PLUS OR MINUS ONE FOOT OF FINISHED GRADE AND VERIFICATION OF COMPACTION RESULTS OBTAINED PRIOR TO THE INSTALLATION OF WATER AND SEWER LINES. RESULTS MUST BE SUBMITTED TO THE DISTRICT ENGINEER.
12. ALL SERVICES WILL BE PERMANENTLY MARKED ON CURB FACE AS FOLLOWS:
"X" FOR SANITARY SERVICE SEWERS
"V" FOR WATER SERVICES
13. NO TREES ALLOWED IN EASEMENTS OR WITHIN 8' OF WATER OR SANITARY SEWER MAINS IN RIGHT OF WAY.
14. THE CONTRACTOR SHALL HAVE IN HIS POSSESSION AT ALL TIMES ONE (1) SIGNED COPY OF THE PLANS WHICH HAVE BEEN APPROVED BY THE PWSD AND THE DISTRICT ENGINEER AND ONE (1) COPY OF THE LATEST PWSD SPECIFICATION MANUAL.

PWSD WATER SYSTEM NOTES

1. ALL MATERIALS AND WORKMANSHIP SHALL BE IN CONFORMANCE WITH THE PWSD ENGINEERING STANDARDS AND SPECIFICATIONS, LATEST REVISION.
2. ALL WATER MAINS SHALL BE PER PWSD MATERIALS SPECIFICATIONS. ALL MATERIALS IN CONTACT WITH POTABLE WATER SHALL BE SUITABLE FOR CHLORINATED AND CHLORAMINATED WATER.
3. ALL BENDS, PLUGS, REDUCERS, AND FIRE HYDRANTS TO BE RODDED OR MEGA-LOGGED. ALL FITTINGS SHALL BE WRAPPED PER PWSD MATERIALS SPECIFICATIONS.
4. THERE SHALL BE A MINIMUM COVER OF 4.5 FEET OVER ALL WATER MAINS.
5. FIRE HYDRANTS SHALL CONFORM TO AWWA C-502 "DRY BARREL FIRE HYDRANTS" PIPE HYDRANT ASSEMBLIES PER PWSD SPECIFICATIONS.
6. ALL BENDS, TEES, FIRE HYDRANTS, BLOW-OFFS, AND PLUGS AT DEAD-END MAINS SHALL BE PROTECTED FROM THRUST WITH CONCRETE THRUST BLOCKS.
7. PRECAUTIONS SHALL BE TAKEN TO PROTECT THE INTERIOR OF PIPES, FITTINGS, AND VALVES AGAINST CONTAMINATION. ALL OPENINGS IN THE PIPELINE SHALL BE CLOSED WITH WATERTIGHT PLUGS WHEN PIPE LAYING IS STOPPED AT THE CLOSE OF THE DAYS WORK OR FOR OTHER REASONS, SUCH AS REST BREAKS OR MEAL PERIODS.
8. VALVES IN STREETS ARE TO BE LOCATED AT PROPERTY LINE EXTENSIONS EXCEPT FOR TAPPING TEES; WHERE AN ADDITIONAL VALVE SHALL BE PLACED ON THE TAPPING TEE. OTHER LOCATIONS SHOWN ON THE PLANS.
9. WHEN NECESSARY TO LOWER OR RAISE WATER LINES AT STORM DRAINS AND OTHER UTILITY CROSSING, A MINIMUM CLEARANCE OF 1.5 FEET SHALL BE MAINTAINED BETWEEN OUTSIDE OF PIPES.
10. THE CONTRACTOR SHALL NOTIFY THE PWSD AT LEAST 48 HOURS PRIOR TO ANY CONSTRUCTION. IF WORK IS SUSPENDED FOR ANY PERIOD OF TIME AFTER INITIAL START-UP, THE CONTRACTOR MUST NOTIFY THE DISTRICT ENGINEER 48 HOURS PRIOR TO RE-START.
11. PIPE BEDDING SHALL BE A CLEAN, WELL-GRADED SAND OR SQUEEGEE SAND IN ACCORDANCE WITH PWSD STANDARDS AND SPECIFICATIONS, LATEST REVISION.
12. THE CONTRACTOR SHALL NOTIFY THE PUBLIC UTILITY COMPANIES AND DETERMINE THE LOCATION OF ALL EXISTING UNDERGROUND UTILITIES PRIOR TO PROCEEDING WITH THE EXCAVATION. ALL WORK IN THE AREA OF THE PUBLIC UTILITIES SHALL BE PERFORMED ACCORDING TO THE REQUIREMENTS OF THESE AGENCIES.
13. COMPACTION OF ALL TRENCHES MUST BE ATTAINED IN ACCORDANCE WITH THE SOILS REPORTS AND COMPACTION TEST RESULTS SUBMITTED TO THE DISTRICT ENGINEER PRIOR TO PROBATIONARY ACCEPTANCE.
14. AT LEAST FIVE (5) DAYS PRIOR TO THE START OF CONSTRUCTION, A PRE-CONSTRUCTION MEETING WILL BE HELD AT THE OFFICE OF THE DISTRICT ENGINEER AND ATTENDED BY THE CONTRACTOR, DESIGN ENGINEER, AND REPRESENTATIVE OF OTHER APPROVING AGENCIES.
15. CHLORINATION AND FLUSHING: ALL WATER MAINS SHALL BE INSTALLED AND CHLORINATED PER PWSD SPECIFICATIONS. CHLORINATION OF FINISHED PIPELINE COMPLETED BEFORE HYDROSTATIC TESTING.
16. HYDROSTATIC TESTING: ALL WATER MAINS SHALL BE TESTED PER THE REQUIREMENTS OF THE PWSD SPECIFICATIONS UP TO MINIMUM OF 150 PSI IN THE PRESENCE OF A PWSD INSPECTOR/ENGINEER.

PWSD SANITARY SEWER SYSTEM NOTES

1. ALL MATERIALS AND WORKMANSHIP SHALL BE IN CONFORMANCE WITH THE PWSD ENGINEERING STANDARDS AND SPECIFICATIONS, LATEST VERSION.
2. ALL SEWER MAINS SHALL BE PVC, ASTM D-3034, SDR 35 OR APPROVED EQUAL. ALL SEWER MAIN SIZE IS 8" IN DIAMETER UNLESS OTHERWISE NOTED.
3. SEWER LINES SHALL BE INSTALLED 5.0 FEET SOUTH OR WEST OF STREET CENTERLINE, UNLESS OTHERWISE SHOWN ON PLANS. SEWER LINES SHALL BE 10.00 FEET FROM WATER LINES EXCEPT WHEN CROSSING EACH OTHER. SEWER LINES WHICH CROSS LESS THAN 1.50 FEET VERTICALLY FROM THE WATER MAIN SHALL BE ENCASED IN CONCRETE AS PER PWSD SPECIFICATIONS. USE RUBBER GASKETS FOR PVC ENCASEMENT.
4. SEWER RIM ELEVATIONS SHOWN ARE APPROPRIATE ONLY AND ARE NOT TO BE TAKEN AS FINAL ELEVATIONS. RING AND COVER SHALL BE SET IN CENTERED CONCRETE RINGS WITH RAM-NECK FOR ADJUSTMENT TO MATCH FINAL PAVEMENT ELEVATIONS.
5. THE CONTRACTOR AND SURVEY CREW SHALL VERIFY ELEVATIONS OF EXISTING SEWER LINES AND MANHOLES TO BE TIED TO PRIOR TO CONSTRUCTION OR STAKING OF SANITARY SEWER.
6. NO UNDERDRAIN SYSTEM WILL BE ALLOWED TO BE PLACED IN MAINLINE OR SEWER SERVICE TRENCHES. SEWER SERVICE TEES FOR EACH UNIT SHALL BE STAKED BY A SURVEY CREW AND FURNISHED AND INSTALLED BY THE CONTRACTOR. THE CONTRACTOR SHALL FURNISH TO THE ENGINEER "AS CONSTRUCTED" LOCATION OF TEES. SEWER WYES SHALL BE USED RATHER THAN TEES.
8. ALL MANHOLES SHALL BE 48-INCHES IN DIAMETER WITH 24-INCH RING AND COVER, ECCENTRIC CONE UNLESS OTHERWISE SPECIFIED. ALL MANHOLES SHALL HAVE SHAPED INVERTS.
9. PIPE BEDDING SHALL BE CLASS "B" AND SHALL CONFORM TO ASTM C-33 OR D-448 GRADATION NO. 6 OR NO. 67.
10. AT LEAST FIVE (5) DAYS PRIOR TO THE START OF CONSTRUCTION, A PRE-CONSTRUCTION MEETING WILL BE HELD AT THE OFFICE OF THE DISTRICT ENGINEER AND ATTENDED BY THE CONTRACTOR AND REPRESENTATIVES OF THE OTHER APPROVING AGENCIES. IT WILL BE THE RESPONSIBILITY OF THE CONTRACTOR TO CONTACT THE DISTRICT ENGINEER TO SCHEDULE THIS MEETING.
11. THE CONTRACTOR SHALL HAVE IN HIS POSSESSION AT ALL TIMES ONE (1) SIGNED COPY OF THE PLANS WHICH HAVE BEEN APPROVED BY THE PWSD AND THE DISTRICT ENGINEER AND ONE (1) COPY OF THE LATEST PWSD SPECIFICATION MANUAL.
12. ALL SEWER LINES SHALL BE TESTED IN ACCORDANCE WITH THE PWSD STANDARDS AND SPECIFICATIONS PRIOR TO ACCEPTANCE OR ANY CONNECTION TO AN EXISTING SEWER LINE.
13. PRIOR TO STARTING WORK WHERE SEWER MAIN IS TO BE CONNECTED TO EXISTING PWSD SEWER SYSTEMS. THE NEAREST MANHOLE TO THE POINT OF TIE-IN SHALL BE PLUGGED WITH A PLUMBER'S PLUG ON THE INLET SIDE BY THE CONTRACTOR. THIS PLUG SHALL REMAIN IN PLACE UNTIL FINAL PROBATIONARY ACCEPTANCE BY PWSD. THE CONTRACTOR SHALL BE RESPONSIBLE FOR PUMPING AND CLEANING THESE MANHOLES AND REMOVING THE PLUG WHEN INSTRUCTED BY THE DISTRICT.
14. PRIOR TO PROBATIONARY ACCEPTANCE WALK-THROUGH, THE CONTRACTOR SHALL JET CLEAN THE ENTIRE SANITARY SEWER SYSTEM AND PUMP OUT AT THE PLUGGED MANHOLE.

CASE NUMBER: Z_____

HORSESHOE RIDGE SUBDIVISION 1ST AMENDMENT

LOT 2, BLOCK 1, HORSESHOE RIDGE SUBDIVISION 1ST AMENDMENT
 A PARCEL OF LAND LOCATED IN THE SE 1/4 OF SECTION 28, TOWNSHIP 6 SOUTH, RANGE 66 WEST OF
 THE 6TH PRINCIPAL MERIDIAN
 PARKER WATER AND SANITATION DISTRICT

LEGEND

	PROPERTY LINE
	WATER LINE
	SEWER LINE
	SEWER CLEANOUT
	GAS LINE
	COMMUNICATION LINE
	POWER LINE



SEAL

PROJECT TITLE

RETAIL

LOT 2, BLOCK 1
 HORSESHOE RIDGE
 PARKER, CO 80134

PREPARED FOR

BRYTAR
 COMPANIES

8117 PRESTON RD. #300
 DALLAS, TX 75225

SUBMITTAL

PWSD

DRAWN BY: BSA

CHECKED BY: MRB

PROJECT NO.: 18-075-001

REVISIONS

2ND SUBMITTAL 10/31/2019

DATE

5/28/2019

SHEET TITLE

OVERALL
 UTILITY PLAN

SHEET INFORMATION

C-3.0

3 of 5

SANITARY SERVICE CONSTRUCTION NOTES

- | | |
|--|---|
| 1 SANITARY CONNECTION AT BUILDING WITH CLEANOUT
IE: 4988.20 | 11 SANITARY CONNECTION AT BUILDING WITH CLEANOUT
IE: 4988.16 |
| 2 10 LF 6" PVC @ 2.0% | 12 10 LF 6" PVC @ 2.0% |
| 3 SANITARY CLEANOUT
IE: 4988.08 | 13 SANITARY CLEANOUT
IE: 4988.14 |
| 4 SANITARY WYE CONNECTION
IE: 4988.00 | 14 SANITARY WYE CONNECTION
IE: 4988.06 |
| 5 5 LF 6" PVC @ 2.0% | 15 22 LF 6" PVC @ 2.0% |
| 6 GREASE INTERCEPTOR
IE IN: 4987.95
IE OUT: 4987.85 | 16 51 LF 6" PVC @ 2.0% |
| 7 5 LF 6" PVC @ 2.0% | 17 CONNECTION AT EXISTING SANITARY MAIN
IE: 4986.60 |
| 8 SAMPLING MANHOLE
IE: 4987.80 | |
| 9 9 LF 6" PVC @ 2.0% | |
| 10 SANITARY WYE CONNECTION
IE: 4987.62 | |

NOTE

THE PROPOSED UTILITY CONNECTION WILL REQUIRE A TOWN RIGHT-OF-WAY PERMIT PRIOR TO COMMENCING WORK. THE TOWN PREFERENCES CONNECTIONS TO BE BORED TO THE EXTENT POSSIBLE, AND ANY STREET CUT ALLOWED BY THE TOWN WILL BE REQUIRED TO BE PATCHED ACCORDING TO THE TOWN'S CONSTRUCTION STANDARDS AND DETAILS. THE LIMITS OF PATCHING WILL BE DETERMINED BY THE TOWN AT THE TIME OF CONSTRUCTION. THE TOWN OF PARKER DOES NOT ALLOW ROADWAY CLOSURES FOR UTILITY WORK.

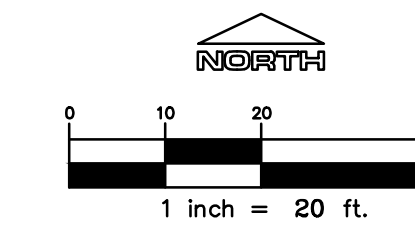
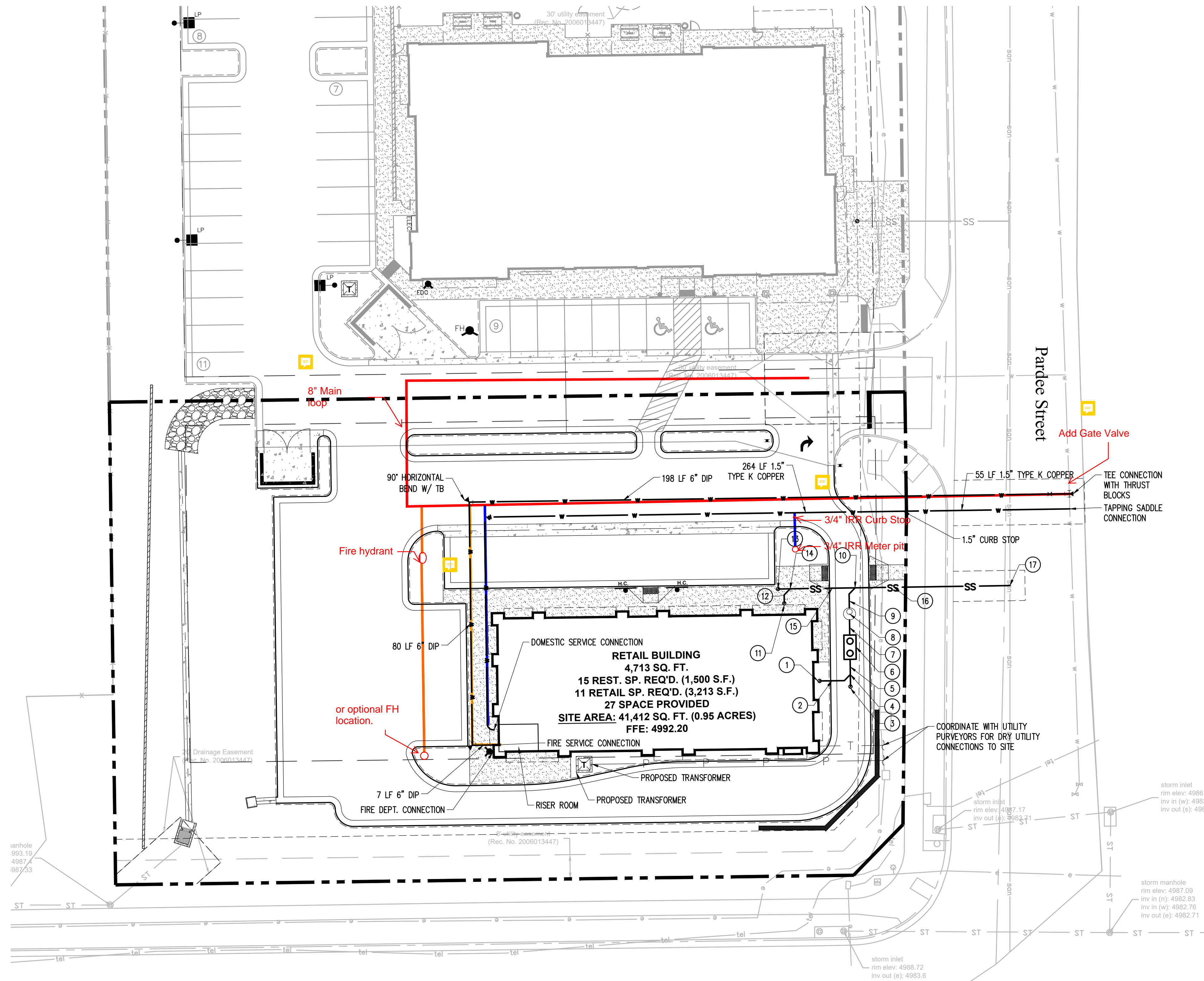

All fire hydrants shall be installed according to water utility standards. The number and locations of the fire hydrants as shown on the Overall Utility Plan are correct as specified by the Town of Parker, Community Development Department.

Fire Code Official or Designated Representative _____ Date _____

(NOTE – Underground Fire Line (UFL) submittal documents must meet the requirements of NFPA 24 when submitting for review.)

The Town of Parker review constitutes general compliance with the Town's Standards and approved variances, subject to these plans being stamped, signed, and dated by the professional engineer of record. Review by the Town does not constitute approval of the plan design or accuracy and correctness of engineering calculations. Errors in the design or calculations remain the responsibility of the registered professional engineer whose stamp and signature are affixed to this document.

This review does not constitute approval of any private on-site improvements which may be shown. Construction cannot commence until all required drainage/traffic report(s), final development plan(s), special review(s), grading permit, and/or other permits are complete, approved and on file with the Town of Parker.

Town of Parker, Director of Engineering _____ Date _____

File: RE - PMSD - ROPAL300.dwg Path: P:\Colorado\Parker\Brytar\PARKER_TLE - 18-075-001\2 Drawings\ Plotted by: Brod Date: 04-Nov-19 11:56:54am

HORSESHOE RIDGE SUBDIVISION 1ST AMENDMENT

LOT 2, BLOCK 1, HORSESHOE RIDGE SUBDIVISION 1ST AMENDMENT

A PARCEL OF LAND LOCATED IN THE SE 1/4 OF SECTION 28, TOWNSHIP 6 SOUTH, RANGE 66 WEST OF THE 6TH PRINCIPAL MERIDIAN

PARKER WATER AND SANITATION DISTRICT

SEAL

PROJECT TITLE
RETAIL

LOT 2, BLOCK 1
 HORSESHOE RIDGE
 PARKER, CO 80134

PREPARED FOR
BRYTAR COMPANIES

8117 PRESTON RD. #300
 DALLAS, TX 75225

INSPECTION POLICY:

- ALL SERVICE INSPECTIONS MUST BE SCHEDULED AT LEAST 24 HOURS IN ADVANCE OF THE REQUESTED INSPECTION.
- SERVICE INSPECTIONS WILL OCCUR BETWEEN 1:00 P.M. AND 3:00 P.M. SPECIFIC INSPECTION TIMES ARE NOT AVAILABLE.
- IF THE CONTRACTOR IS NOT READY FOR INSPECTION WHEN THE INSPECTOR ARRIVES AT THE SITE OR SERVICE FAILS, A RE-INSPECTION WILL HAVE TO BE SCHEDULED IN ACCORDANCE WITH NOTES 1 AND 2 ABOVE AND A RE-INSPECTION FEE CHARGED.
- SHOULD THE SERVICE LINES BE DAMAGED BY LATER CONSTRUCTION, AN INSPECTION OF THE REPAIR WILL BE REQUIRED IN ACCORDANCE WITH NOTES 1 AND 2 ABOVE.
- THE CONTRACTOR SHALL LEAVE ALL PIPE AND FITTINGS EXPOSED FOR THE INSPECTOR TO OBSERVE. INSPECTORS WILL NOT ENTER ANY EXCAVATIONS TO CHECK MATERIALS. THE TOP LAYER OF BEDDING CAN BE ADDED AFTER THE INSPECTION HAS BEEN COMPLETED.
- ALL EXCAVATIONS SHALL BE IN ACCORDANCE WITH OSHA STANDARDS.
- LOTS WITHOUT BUILDING ADDRESSES BEFORE DISTRICT INSPECTION OR METER SET WILL FAIL AUTOMATICALLY.
- CONTRACTOR MUST BE PRESENT AT TIME OF INSPECTION. UNLESS COORDINATED WITH DISTRICT INSPECTOR.

INSTALLATION NOTES:

WATER

- ACCEPTABLE PIPE MATERIALS SHALL BE K-COPPER TUBING. (3/4" MIN.)
- APPROVED BEDDING TO BE SQUEEGEE.
- ONLY ONE COUPLING WILL BE ALLOWED BETWEEN THE STUB-IN AND BUILDING. COMPRESSION COUPLINGS WILL NOT BE ALLOWED ON NEW CONSTRUCTION. SILVER SOLDERED JOINTS MUST BE USED ON SERVICES LARGER THAN 3/4". SILVER SOLDERED JOINTS MUST BE INSPECTED BY PWSO PRIOR TO BURIAL. FLARED COUPLINGS WILL BE ALLOWED ON ALL SERVICES 3/4" AND SMALLER.
- A WATER SERVICE WHICH CROSSES A SEWER SERVICE CAN DO SO ONLY AT A 45-90° ANGLE. WATER SERVICES SHALL BE LOCATED A MINIMUM OF 18" ABOVE SEWER SERVICE.
- WATER SERVICE FOUNDATION PENETRATIONS SHALL BE WATERPROOFED USING MASTIC OR OTHER APPROVED METHOD. CRAWL SPACE REQUIRES CONTINUOUS COPPER WITH A 1" BURY.
- CURB STOP MUST BE PLUMB AND CENTERED OVER THE NUT. IT SHOULD BE STRAPPED TO THE METER PIT (RESIDENTIAL INSTALLATIONS) OR CENTERED OVER THE EASEMENT LINE (COMMERCIAL INSTALLATIONS). THE ASSEMBLY MUST BE AT OR SLIGHTLY ABOVE FINISHED GRADE.
- MOVED CURB BOXES MUST BE INSPECTED BY PWSO PRIOR TO BURIAL.
- WATERLINE MUST BE ATTACHED TO A SUPPORT BOARD THAT IS MOUNTED TO THE WALL.
- NO VOIDS ALLOWED UNDER WATERLINES FROM STOP BOX TO FOUNDATION.
- CURBSTOP BOXES AND METER PITS CANNOT BE IN DRIVEWAYS.
- ONLY 3/4" (JUMPER) PIPES (RESIDENCES) ARE ALLOWED. (JUMPER) PIPES WILL BE REMOVED PRIOR TO METER SET DATE.
- ALL SERVICES WILL BE PERMANENTLY MARKED ON CURB FACE AS FOLLOWS:
 "X" FOR SANITARY SEWER SERVICE
 "Y" FOR WATER SERVICES
- NO SPLICES OR FLARED COUPLINGS ALLOWED ON SERVICES LARGER THAN 3/4". SILVER SOLDERED JOINTS MUST BE INSPECTED BY PWSO PRIOR TO BURIAL. FLARED COUPLINGS WILL BE ALLOWED ON ALL SERVICES 3/4" AND SMALLER.

PARKER WATER & SANITATION DISTRICT
 DISTRICT POLICIES & INSTALLATION NOTES FOR WATER SERVICES

SCALE: NONE DATE: 2/96
 APPROVED: 1/04 1/16 10/16
 PVR DIRECTOR OF ENGINEERING

2016 REVISION SHEET W1.1

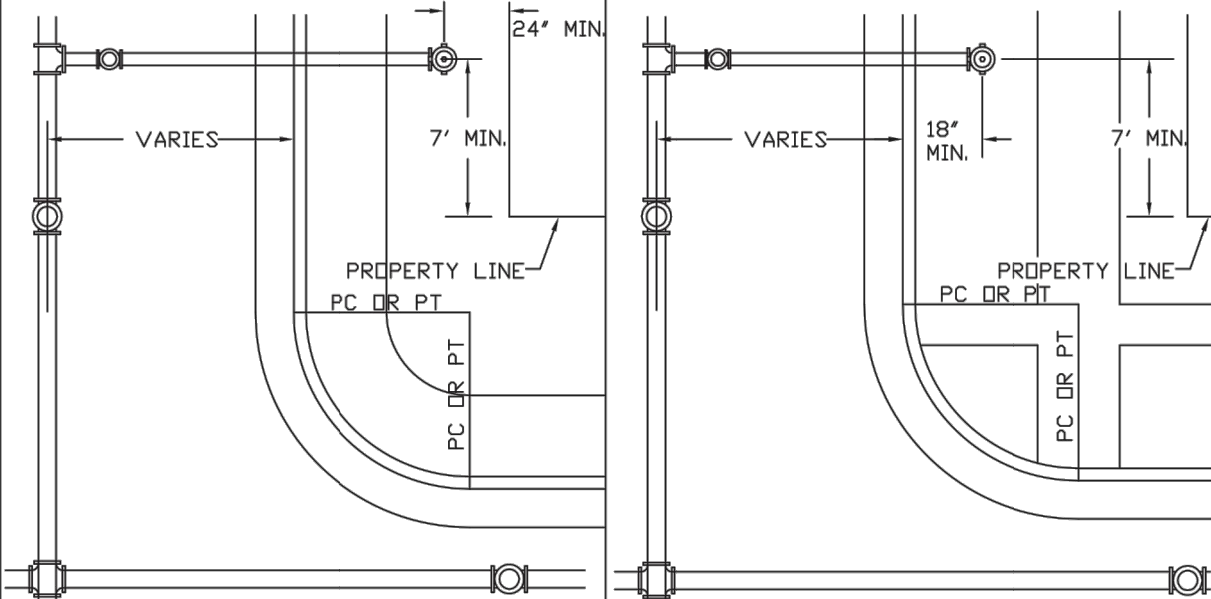
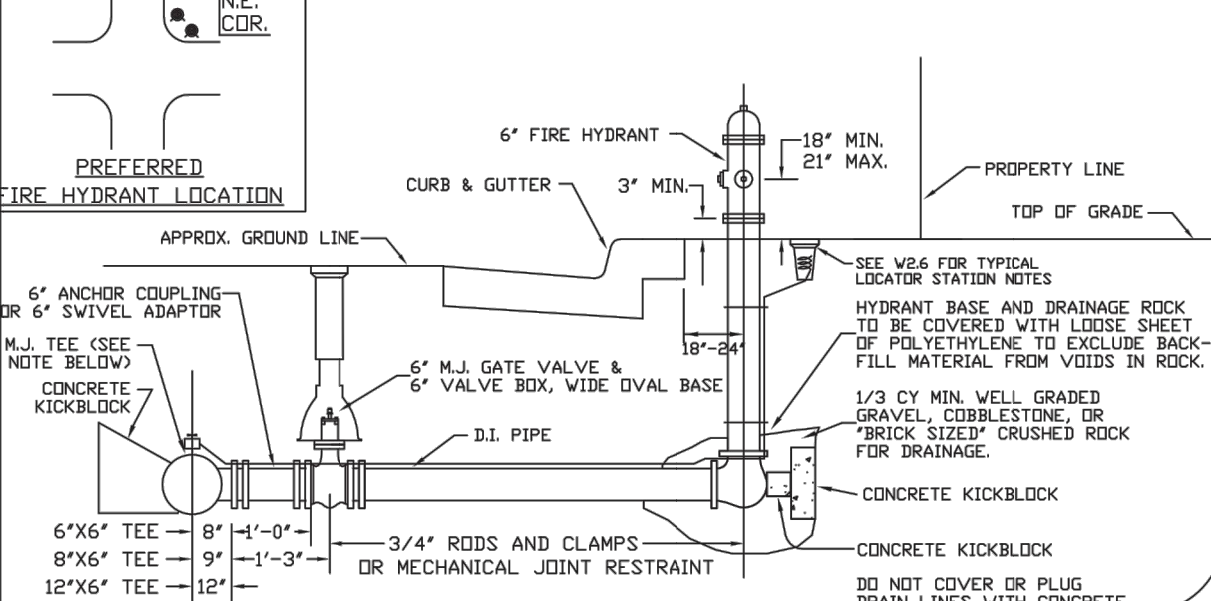



PARKER WATER & SANITATION DISTRICT
 FIRE HYDRANTS LOCATION & INSTALLATION

SCALE: NONE DATE: 2/96
 APPROVED: 4/01 10/16 01/02 12/07 1/16
 PVR DIRECTOR OF ENGINEERING

2016 REVISION SHEET W2.5

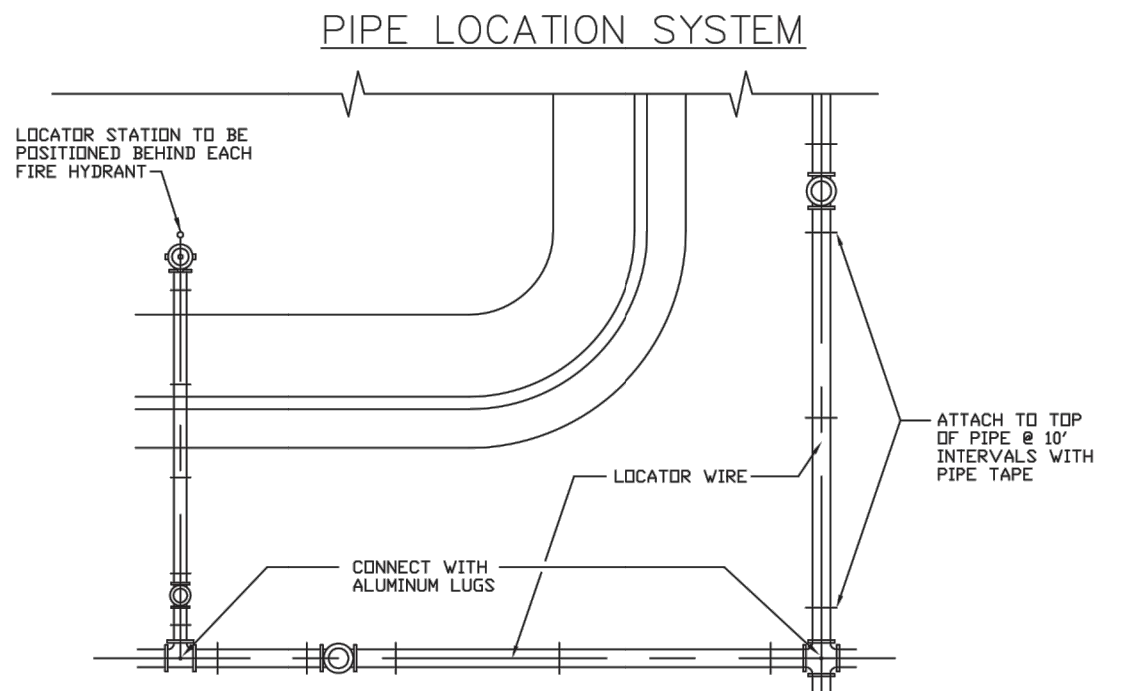
PIPE LOCATION SYSTEM



PLAN

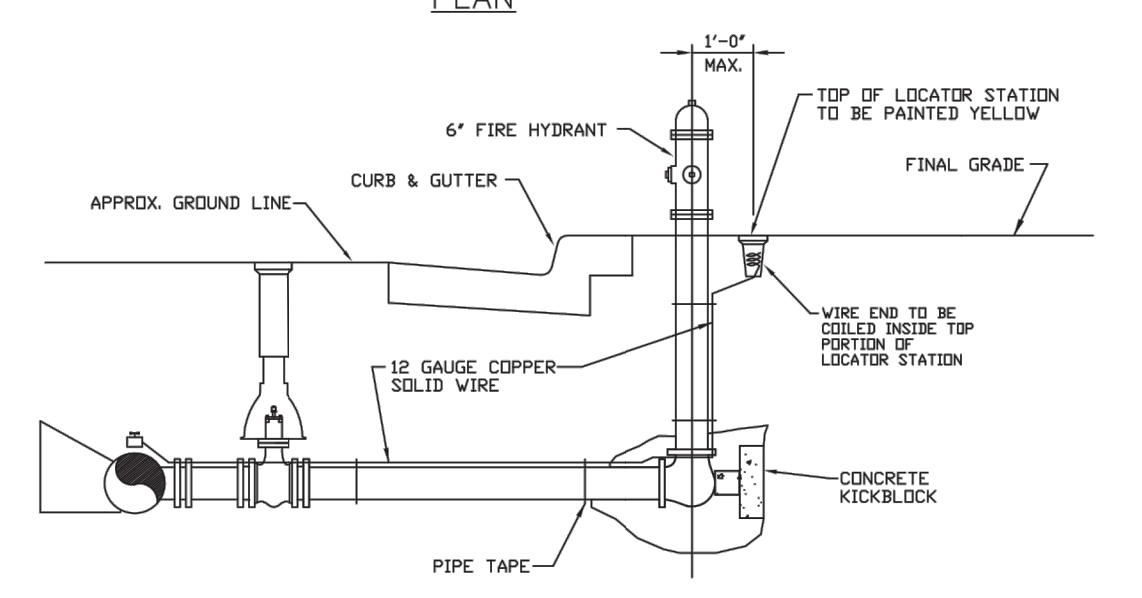

SECTION VIEW @ FIRE HYDRANT

PARKER WATER & SANITATION DISTRICT
 LOCATOR WIRE DETAILS

SCALE: NONE DATE: 2/96
 APPROVED: 4/01 01/02 01/16 10/16
 PVR DIRECTOR OF ENGINEERING

2016 REVISION SHEET W2.6

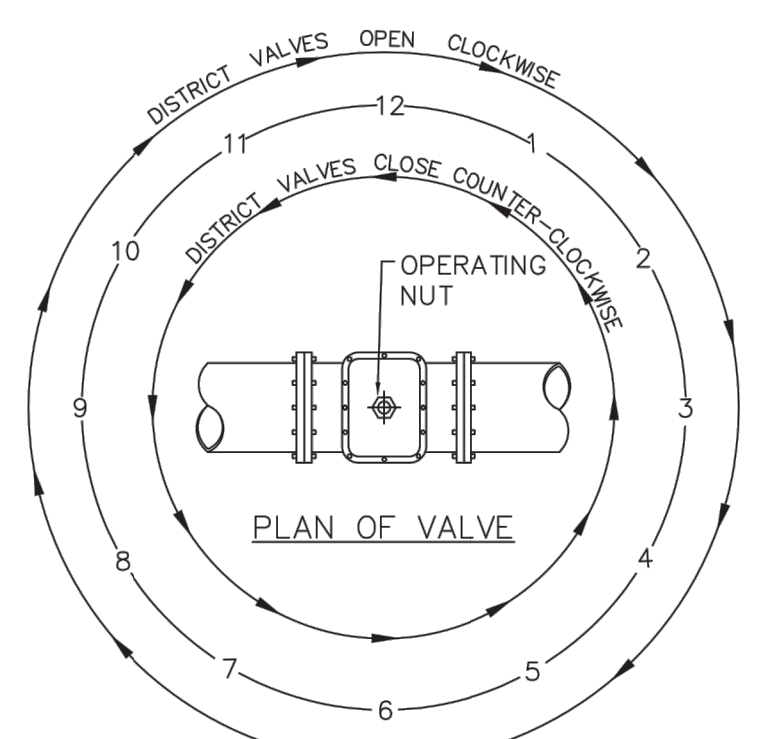

VALVE OPENING & CLOSING PROCEDURE

NOTE:
 ONLY RIGHT HAND OPENING VALVES ALLOWED.

PARKER WATER & SANITATION DISTRICT
 VALVE OPERATION

SCALE: NONE DATE: 2/96
 APPROVED: 1/16 10/16
 PVR DIRECTOR OF ENGINEERING

2016 REVISION SHEET W3.4

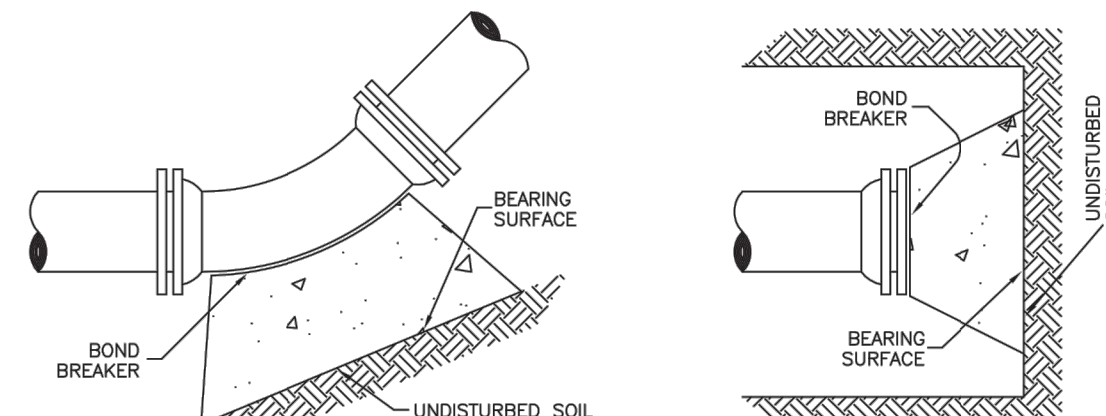

11-1/4, 22-1/2, 45° & 90° BENDS

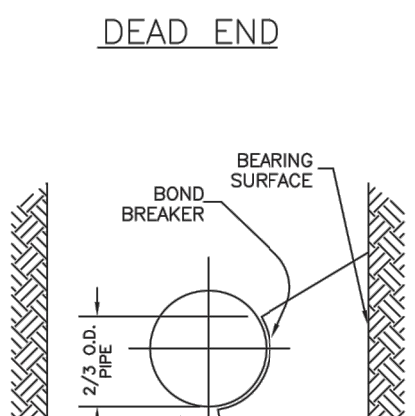

DEAD END

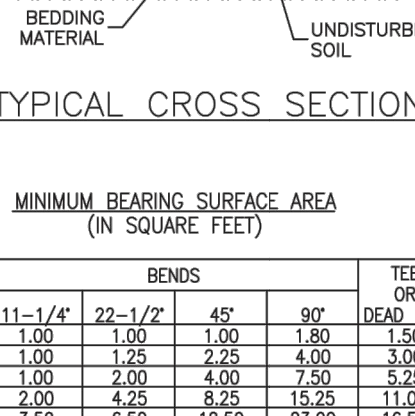

TYPICAL CROSS SECTION

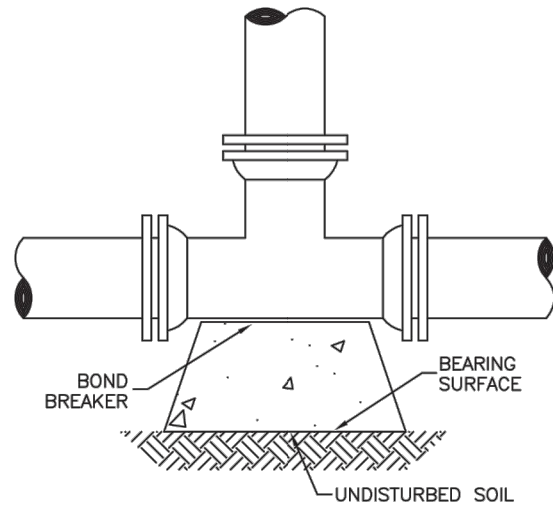

TEE

MINIMUM BEARING SURFACE AREA (IN SQUARE FEET)

SIZE OF PIPE	11-1/4"	22-1/2"	45"	90"	TEE OR DEAD END
4"	1.00	1.00	1.00	1.80	1.50
6"	1.00	1.75	2.25	4.00	3.00
8"	1.00	2.00	3.00	7.50	3.25
12"	2.00	4.25	8.25	15.25	11.00
16"	3.50	6.50	12.50	23.00	16.50
20"	5.00	10.00	19.50	35.50	23.00
24"	6.50	13.00	26.00	47.00	33.00

PARKER WATER & SANITATION DISTRICT
 CONCRETE KICKBLOCKS BEARING SURFACES AND INSTALLATION

SCALE: NONE DATE: 2/96
 APPROVED: 4/01 1/16 10/16
 PVR DIRECTOR OF ENGINEERING

2016 REVISION SHEET W3.18

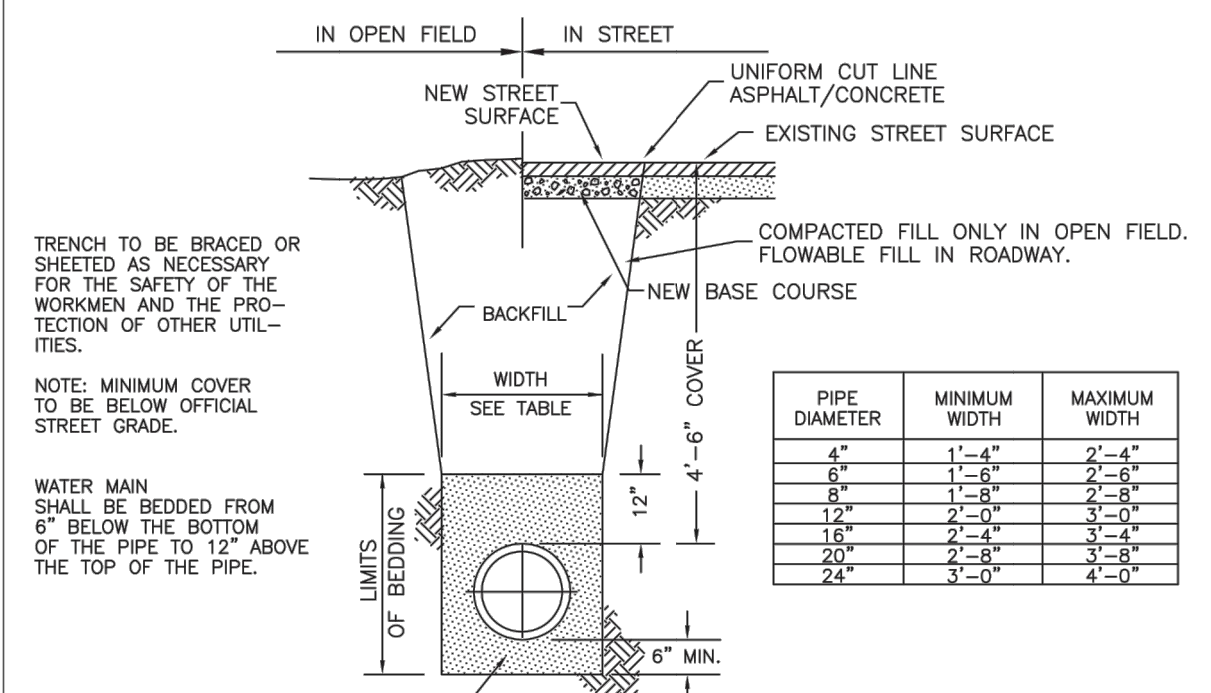

STANDARD TRENCH SECTION

PIPE DIAMETER	MINIMUM WIDTH	MAXIMUM WIDTH
4"	1'-4"	2'-4"
6"	1'-8"	2'-8"
8"	1'-8"	2'-8"
12"	2'-4"	3'-4"
16"	2'-4"	3'-4"
20"	2'-8"	3'-8"
24"	3'-0"	4'-0"

PARKER WATER & SANITATION DISTRICT
 TYPICAL TRENCH SECTION PIPE PROTECTION

SCALE: NONE DATE: 2/96
 APPROVED: 1/16 10/16
 PVR DIRECTOR OF ENGINEERING

2016 REVISION SHEET W4.1

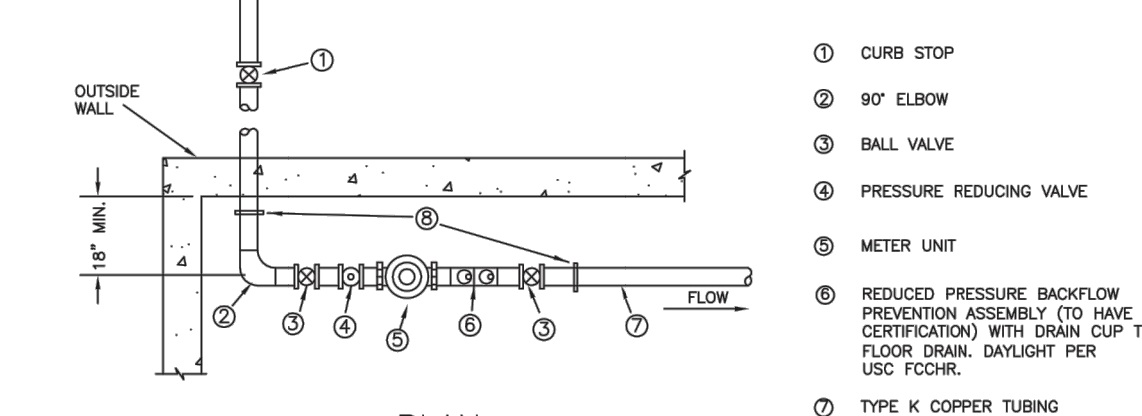

PLAN

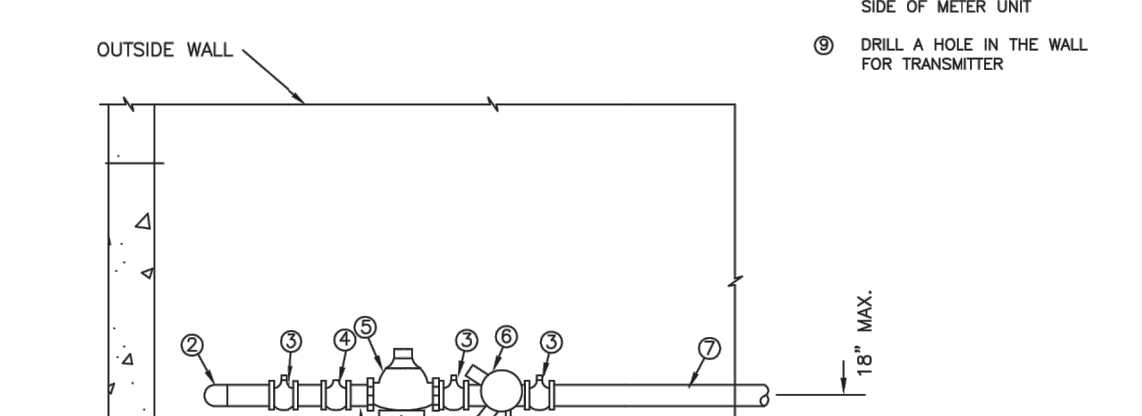

ELEVATION

PARKER WATER & SANITATION DISTRICT
 INSIDE SETTING FOR 1 1/2" & 2" METER

SCALE: NONE DATE: 2/96
 APPROVED: 8/98 01/02 01/16 2/00 08/05 10/16 4/01 07/08
 PVR DIRECTOR OF ENGINEERING

2016 REVISION SHEET W5.14

File: RE - PWSO - ROPAI400.dwg Path: P:\Colorado\Parker\Brytar\PARKER TLE - 18-075-001\2 Drawings\ Plotted by: Brad Date: 31-Oct-19 8:49:21am

SUBMITTAL
PWSO

DRAWN BY: BSA
 CHECKED BY: MRB
 PROJECT NO.: 18-075-001

REVISIONS
 2ND SUBMITTAL 10/31/2019

DATE
5/28/2019

SHEET TITLE
WATER AND SANITARY DETAILS

SHEET INFORMATION
C-4.0

HORSESHOE RIDGE SUBDIVISION 1ST AMENDMENT

LOT 2, BLOCK 1, HORSESHOE RIDGE SUBDIVISION 1ST AMENDMENT
A PARCEL OF LAND LOCATED IN THE SE 1/4 OF SECTION 28, TOWNSHIP 6 SOUTH, RANGE 66 WEST OF
THE 6TH PRINCIPAL MERIDIAN
SITE PLAN REVIEW

PLANT NOTES

- ALL PLANT MATERIAL SHALL MEET SPECIFICATIONS OF THE AMERICAN ASSOCIATION OF NURSERYMEN (AAN) FOR NUMBER ONE GRADE. ALL TREES SHALL BE BALLED AND BURLAPPED OR EQUIVALENT.
- ALL LOW PERENNIAL AND GROUND COVER PLANTING AREA SHALL BE MULCHED WITH WESTERN RED CEDAR WOOD MULCH AT A DEPTH OF 2". WEED FABRIC BARRIER IS NOT REQUIRED.
- NO SHRUBS SHALL BE PLANTED WITHIN FIVE (5) FEET OR TREES WITHIN (10) FEET OF POTABLE AND NONPOTABLE WATER METERS, FIRE HYDRANTS, SANITARY SEWER MANHOLES, OR POTABLE WATER, SANITARY SEWER, AND NON POTABLE IRRIGATION MAINS AND SERVICES.
- DEVELOPER SHALL ENSURE THAT THE LANDSCAPE PLAN IS COORDINATED WITH THE PLANS DONE BY OTHER CONSULTANTS SO THAT THE PROPOSED GRADING, STORM DRAINAGE, OR OTHER CONSTRUCTION DOES NOT CONFLICT NOR PRECLUDE INSTALLATION AND MAINTENANCE OF LANDSCAPE ELEMENTS ON THIS PLAN.
- ALL LANDSCAPE AREAS WITHIN THE SITE SHALL BE IRRIGATED WITH AN AUTOMATIC UNDERGROUND IRRIGATION SYSTEM. AN IRRIGATION PLAN WILL BE PROVIDED AFTER FIRST ROUND OF REVIEW.
- ALL TURF AREAS TO BE SODDED AND IRRIGATED WITH AN AUTOMATIC POP-UP IRRIGATION SYSTEM. ALL SHRUB BEDS AND TREES ARE TO BE IRRIGATED WITH AN AUTOMATIC IRRIGATION (TRICKLE) IRRIGATION SYSTEM, OR ACCEPTABLE ALTERNATIVE. THE IRRIGATION SYSTEM IS TO BE ADJUSTED TO MEET THE WATER REQUIREMENTS OF THE INDIVIDUAL PLANT MATERIAL.
- ALL SHRUB BEDS TO BE MULCHED 3" DEEP WITH 3/4" - 2" RIVER ROCK PLACED ON WEED BARRIER FABRIC.
- EDGING BETWEEN GRASS AND SHRUB BEDS SHALL BE 1/8" X 4" STEEL SET LEVEL WITH TOP OF GRADE.
- TOPSOIL. TO THE MAXIMUM EXTENT FEASIBLE, TOPSOIL THAT IS REMOVED DURING CONSTRUCTION ACTIVITY SHALL BE CONSERVED FOR LATER USE.
- SOIL AMENDMENTS. PRIOR TO INSTALLATION OF PLANT MATERIALS, AREAS THAT HAVE BEEN COMPACTED OR DISTURBED BY CONSTRUCTION ACTIVITY SHALL BE THOROUGHLY LOOSENEED. 4 CU. YRDS./1000 SQ. FT. OF ORGANIC AMENDMENTS SUCH AS COMPOST, PEAT, OR AGED MANURE SHALL BE THOROUGHLY INCORPORATED INTO THE SOIL.

MINIMUM STANDARDS

PERIMETER LANDSCAPING CALCULATIONS						
	TYPE BASE STANDARD (PLANTS PER # LINEAR FEET)	LINEAR FRONTAGE	TREES REQUIRED	SHRUBS REQUIRED	TREES PROPOSED	SHRUBS PROPOSED
WEST	1 TREE-5 SHRUBS/25'	159 L.F.	6.36	31.8	7 TREES	34 shrubs
SOUTH	1 TREE/40'	242 LF	6	0	7	0
EAST	1 TREE-5SHRUBS/40'	126 L.F.	3	0	3 EXISTING	0

PLANT REQUIREMENTS

MINIMUM SITE LANDSCAPE CALCULATIONS FOR 41,412 sq ft LOT		
DESCRIPTION	REQUIRED OR ALLOWED	PROVIDED
LANDSCAPE AREA 15% of Lot	6,211 sq ft	15,471 sq ft
TREES 1/1,500 sq ft	4.14	7 SHADE TREES
SHRUBS 5/1,500 sq ft	21	54 EXCLUDING PARKING ISLANDS ADDITIONAL 32 IN PARKING ISLANDS
MAX. IRRIGATED TURF = 15%	931.65 sq ft max.	0 sq ft
EVERGREEN TREES	40% - 60%	6 EVERGREEN / 13 TREES 46%
75% OF LIVE COVER	11,603 sq ft	13,693 sq ft

PWSD WATER CALCULATIONS							
LANDSCAPE AREA	HIGH WATER TURF (6,000 SF) = 1 SFE	LOW WATER NAT. GRASS & TREES 10,000 SF = 1 SFE	DRIP IRRIG. AREA (20,000 SF = 1 SFE)	NON-IRRIG. AREAS	SUB-TOTAL OF AREAS	PWSD ONE SFE PER 6000	SFE REQ. (SUB-TOTAL CALC. DIV. BY 6000 = REQ.)
15,471 sq ft	0 SF x 1 = 0	0 SF x 1 = 0	10,288 SF x .3 = 3,086.4	5,183 SF x 0 = 0	3,086.4	6000	.5 SFE's

A PLANTING DETAIL FOR ALL TREES & B&B SHRUBS

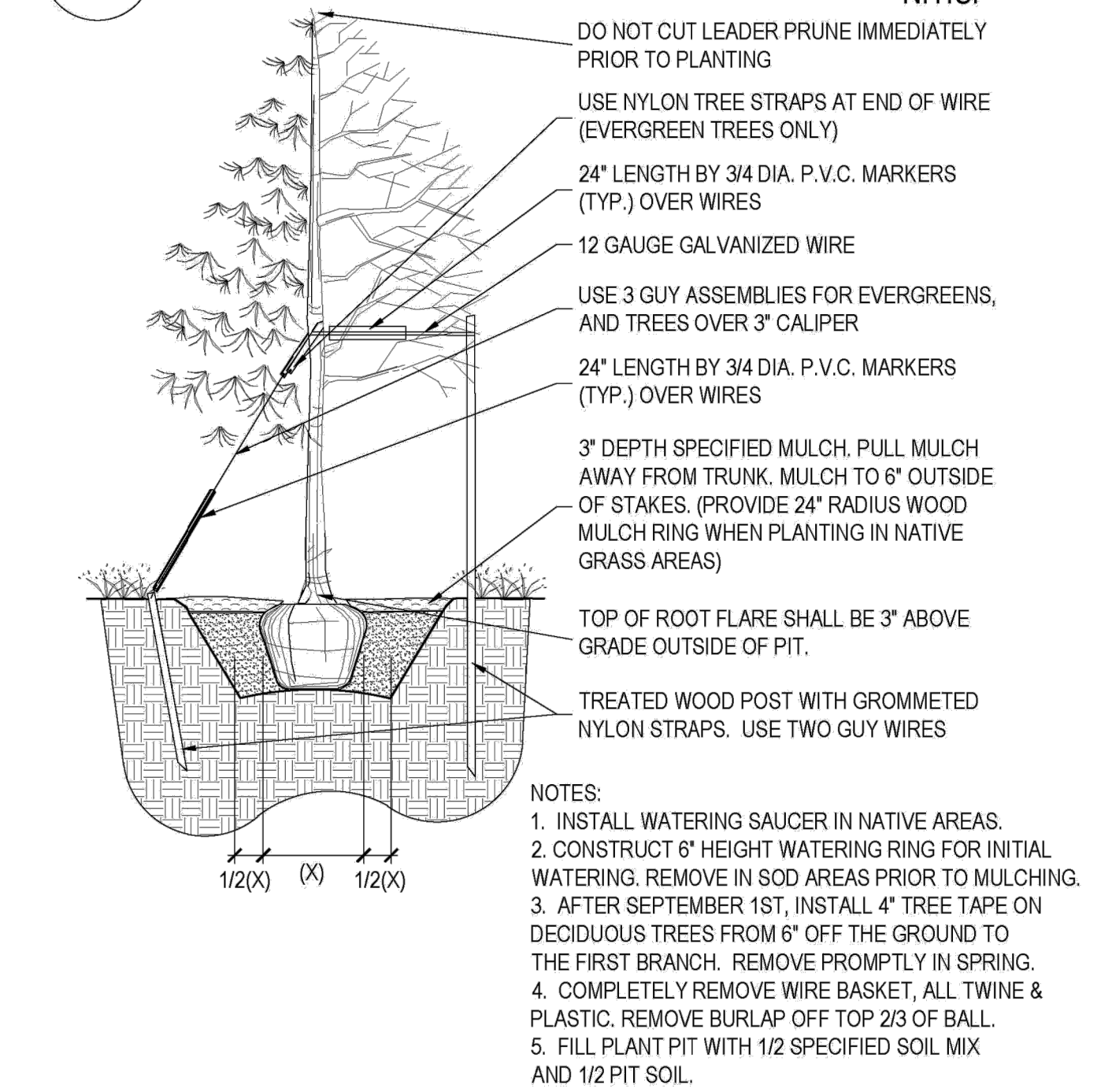

B PLANTING DETAIL FOR SHRUBS, AND ALL CONTAINER PLANTS LARGER THAN 1 GALLON

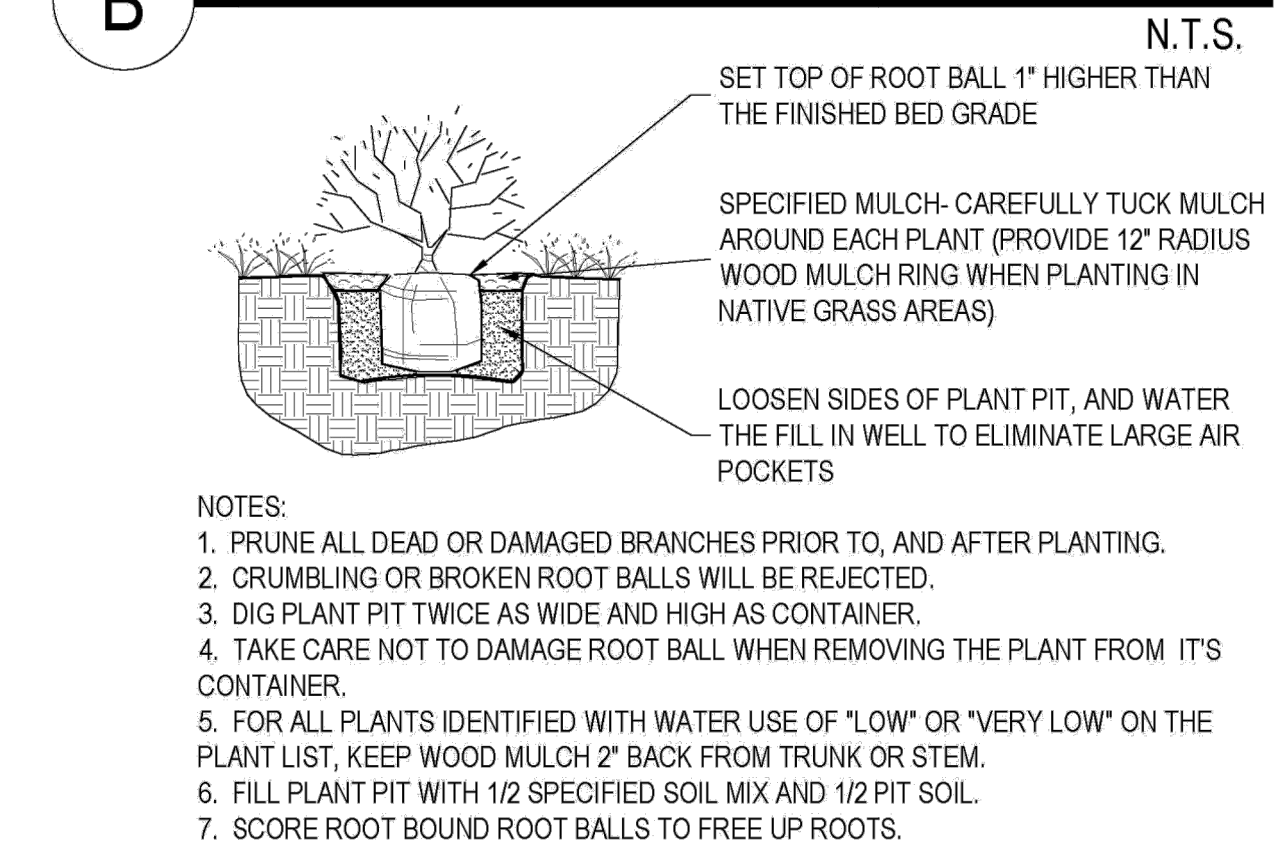

C LANDSCAPE BOULDER

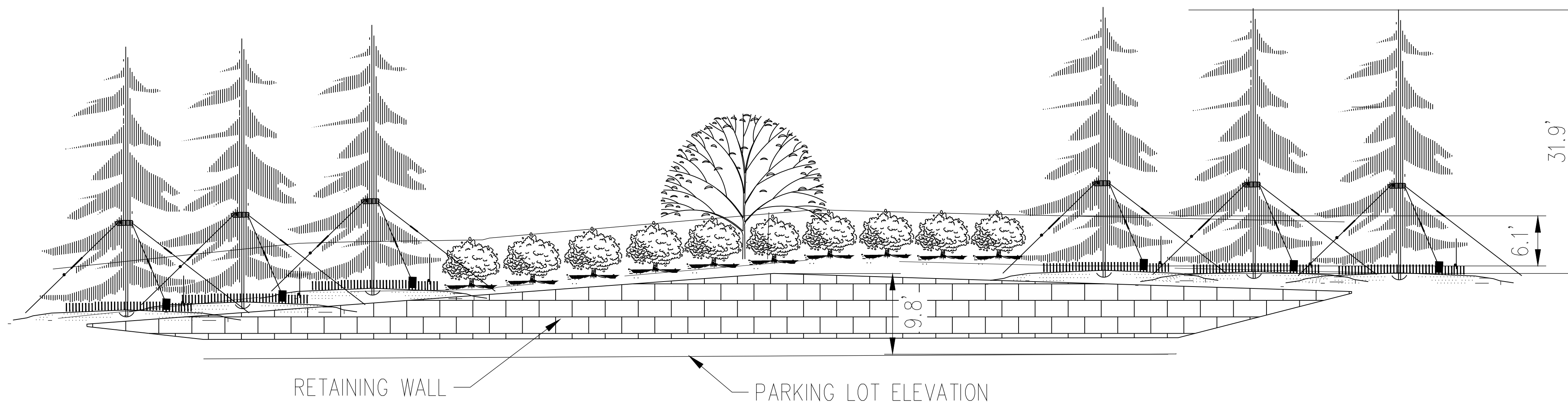
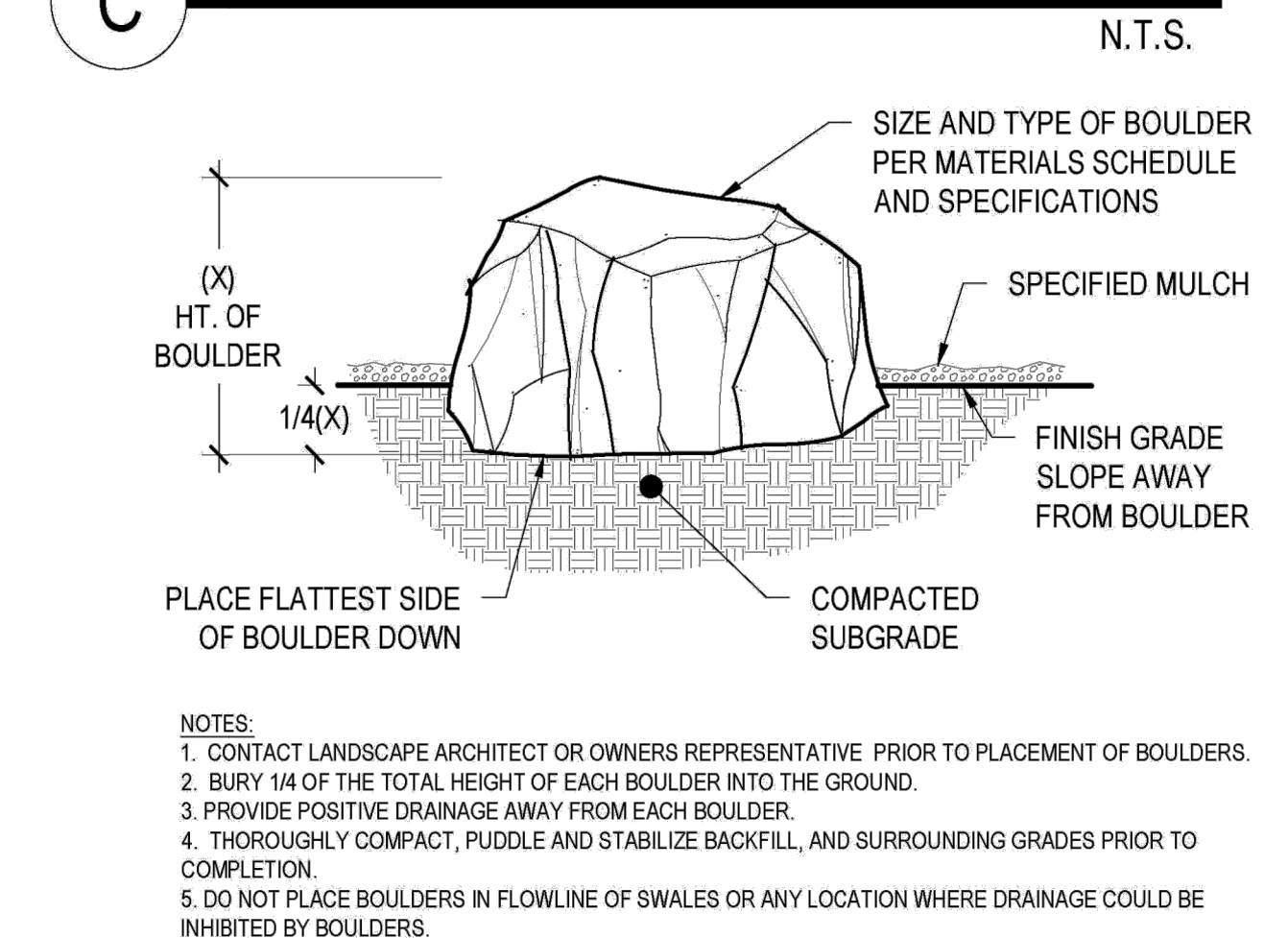

WEST ELEVATION

PROJECT TITLE

RETAIL

LOT 2, BLOCK 1
HORSESHOE RIDGE
PARKER, CO 80134

PREPARED FOR

BRYTAR
COMPANIES

8117 PRESTON RD. #300
DALLAS, TX 75225

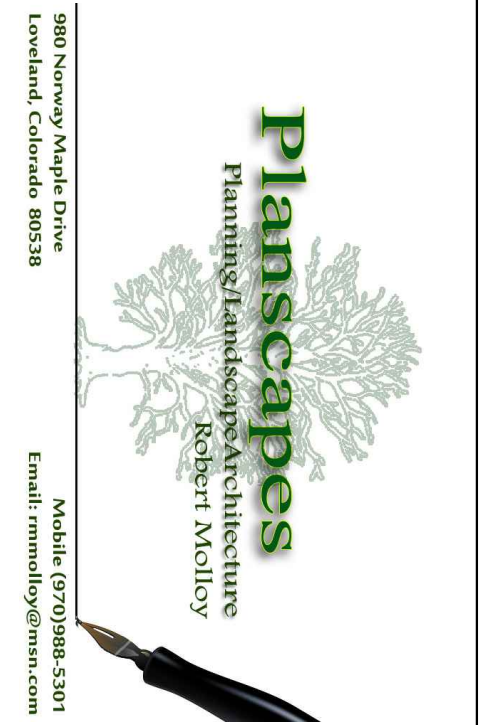

SUBMITTAL

SITE PLAN REVIEW

DRAWN BY: BSA

CHECKED BY: MRB

PROJECT NO.: 18-075-001

REVISIONS

DATE

5/28/2019

SHEET TITLE

LANDSCAPE
DETAILS

SHEET INFORMATION

LS 1.1



Landscape/Irrigation Worksheet

Project Name: _____

Landscape/Irrigation Tap address (physical location of tap) _____

	High Water TURF (6,000sf = 1 SFE)	Low Water Native Grass and Spray Shrubs & Perennials (10,000sf = 1 SFE)	Drip Irrigated area (20,000sf = 1 SFE)	Non-Irrigated area (calculated)	Sub-Total of PWS D one SFE per 6000	SFE Requirement (Sub-Total Calculation divided by 6000 = requirement)
Area #1	_____sf x 1 = _____	_____sf x .6 = _____	_____sf x .3 = _____	_____sf x 0 = _____0_____	_____sf 6,000	_____SFE's

Worksheet Completed by: _____
 Company: _____
 Address: _____
 Phone #: _____

Owner/Developer: _____
 Attn: _____
 Billing Address: _____
 Phone #: _____

ET Controller (with Rain Sensor)

Manufacturer	_____
Model number	_____

Tap Size Requirements:
 0 - 1 SFE's requires a 3/4-inch tap
 1.1 - 2.0 SFE's requires a 1-inch tap
 2.1 - 4.0 SFE's requires a 1 1/2-inch tap
 4.1 - 7.0 SFE's requires a 2-inch tap
 7.1 - 16.0 SFE's requires a 3-inch tap