



Town of Parker Community Development Department  
Development Review Division  
Attention: **BrieAnna Simon**

Application Type: **Site Plan**  
Status: **First Referral**  
Application Name: B1 L2 Horseshoe Ridge – Multi Tenant Commercial Building  
Case/AP#: **SP19-062**  
Referral Received: June 19, 2019  
Comments Due: July 18, 2019

Application Location: Generally located at the n/w corner of Hess Road and Motsenbocker Road

Review date: **July 12, 2019**  
Plan reviewer: **Randall L. Capra**, [rcapra@parkeronline.org](mailto:rcapra@parkeronline.org)  
Phone: 303.805.3169

**TOWN OF PARKER - FIRE/LIFE SAFETY:**

**C REVIEWED FOR CODE COMPLIANCE w/COMMENTS**

- 1<sup>st</sup> Submittal – Reviewed July 12, 2019
- 2<sup>nd</sup> Submittal – Reviewed November 20, 2019 (*comments in red, italicized font*)
- 3<sup>rd</sup> Submittal – Reviewed March 2, 2020 (*comments in bold, red, italicized font*)

**Narrative:** The applicant, is proposing a 5,000 sq. ft. multi-tenant retail building in Horseshoe Ridge on the northwest corner of Hess Road and Pardee Street. The applicant is indicating that the bulk of the building will be home to two A-2 occupancies and one mercantile occupancy.

**Code Reference:** 2018 International Fire Code, 2018 International Building Code, 2017 NEC

#### UNRESOLVED ISSUES/COMMENTS

1. The applicant shall be aware that no vertical construction on this site will be allowed until such time that curb gutter and first lift of asphalt are installed; a site inspection will be required to ensure that this requirement is made prior to allowing vertical construction to commence. *Satisfied; applicant has acknowledged with current submittal.*
2. The applicant shall be aware that the Town of Parker has officially adopted the 2018 ICC codes as of January 1, 2019; all submittal documents are required to comply with the 2018 ICC codes. *Satisfied; applicant has acknowledged with current submittal.*
3. The applicant shall provide an auto turn analysis indicating that apparatus can navigate all portions of this site (both sides of the gas canopy); NO PARKING – FIRE LANE signage is required for any portion of the access where the 20-foot clear width requirement cannot be met. *Satisfied; applicant addressed with current submittal.*
4. The Town of Parker requires that fire apparatus access roads meet the clear-width and weight-bearing standards of the jurisdiction in which the project is located. Roadways shall be designed to support the imposed weight of fire apparatus, 30-ton two axle and 40 ton three axle vehicles. An unimpeded clear width of 20 feet shall be maintained at all times. As such, any location where parked vehicles would obstruct this clear width requirement will require “NO PARKING – FIRE LANE” signage. *This signage shall be red on white. Update design criteria has been provided at the end of this document; ensure compliance when resubmitting.*
5. During pre-application discussions, the applicant indicated that the building would be used for assembly occupancies; the project narrative indicates that two of the three suites envisioned for this building are to be group A-2 occupancies. The applicant further indicated (during the pre-application meetings) that the building would be sprinkled due to group A-2 occupancies (Note – any building/occupancy that has an occupant load of more than 99 occupants is required to be sprinklered. Occupant loads are figured based upon use with the suite i.e. queuing and waiting areas are figured at 1 person per 5 sf and seating areas are figured at 1 per 15 sf. Using just 1600



# Underground Fire Line - Submittal Requirements

Reference: 2013 NFPA 24 [Installation of Private Fire Service Mains and Their Appurtenances](#)

A separate permit is required and will be issued pending review of a detailed submittal which must include the following: [15 IFC 901.2]

4.1.1 Working plans shall be submitted for approval to the authority having jurisdiction before any equipment is installed or replaced.

4.1.2 Deviation from approved plans shall require permission of the authority having jurisdiction.

4.1.3 Working plans shall be drawn to an indicated scale on sheets of uniform size, with a plan of each floor as applicable, and shall include the following items that pertain to the design of the system:

- (1) Name of owner
- (2) Location, including street address
- (3) Point of compass
- (4) A graphic representation of the scale used on all plans
- (5) Name and address of contractor
- (6) Size and location of all water supplies
- (7) The following items that pertain to private fire service mains:
  - (a) Size
  - (b) Length
  - (c) Location
  - (d) Material (ductile-iron, PVC., etc.)
  - (e) Point of connection to city main
  - (f) Sizes, types, and locations of valves, depth at which the top of the pipe is laid below grade
  - (g) Method of restraint (Meg-a-Lug or similar)

4.1.4 The working plan submittal shall include the manufacturer's installation instructions for any specially listed equipment, including descriptions, applications, and limitations for any devices, piping, or fittings. Submittals must include installation specifications for thrust blocks, corrosion protection, restraint system, bedding, detail of pipe under the building up to, and including, the flange. When it is intended that a different contractor will extend the fire line from a stopping point outside the building, to the inside flange, a second submittal and permit is required.

**All tees, plugs, reducers, valves, and hydrant branches shall be restrained against movement by thrust blocks [10.8.2] or restrained joint systems [10.8.3]. When thrust blocks are used as part of the pipe restraint system, submitted plans shall provide detailed documentation that the thrust blocks satisfy all requirements of Section 10.8.2, including specific thrust block dimensions and mathematical calculations for block dimensions per guidelines provided in Annex A.10.8.2.**

Any individual or company who physically works on or installs any part of a fire suppression system, including underground supply lines, from public water lines to system risers and backflow preventers, **must** be registered with the Colorado Division of Fire Safety. [Dept of Public Safety, Division of Fire Safety, Fire Suppression Program 8 CCR 1507-11:3.1.2] Documentation of valid annual registration may be required with plan submittal.

The following website for the Colorado Division of Fire Safety will provide registration instructions.

<http://dfs.state.co.us/SuppAppsProclnsp.htm>

All submittals must display a wet stamp and original signature by a Colorado licensed professional engineer or NICET III, or higher, in fire suppression systems. [Dept. of Public Safety, Division of Fire Safety, Fire Suppression Program 8 CCR 1507

## **FIRE ACCESS ROAD DESIGN CRITERIA**

**VEHICLE SPECIFICATIONS** are provided for the largest apparatus in use by South Metro Fire Rescue. Fire Apparatus Access Roads shall be capable of accommodating this apparatus.

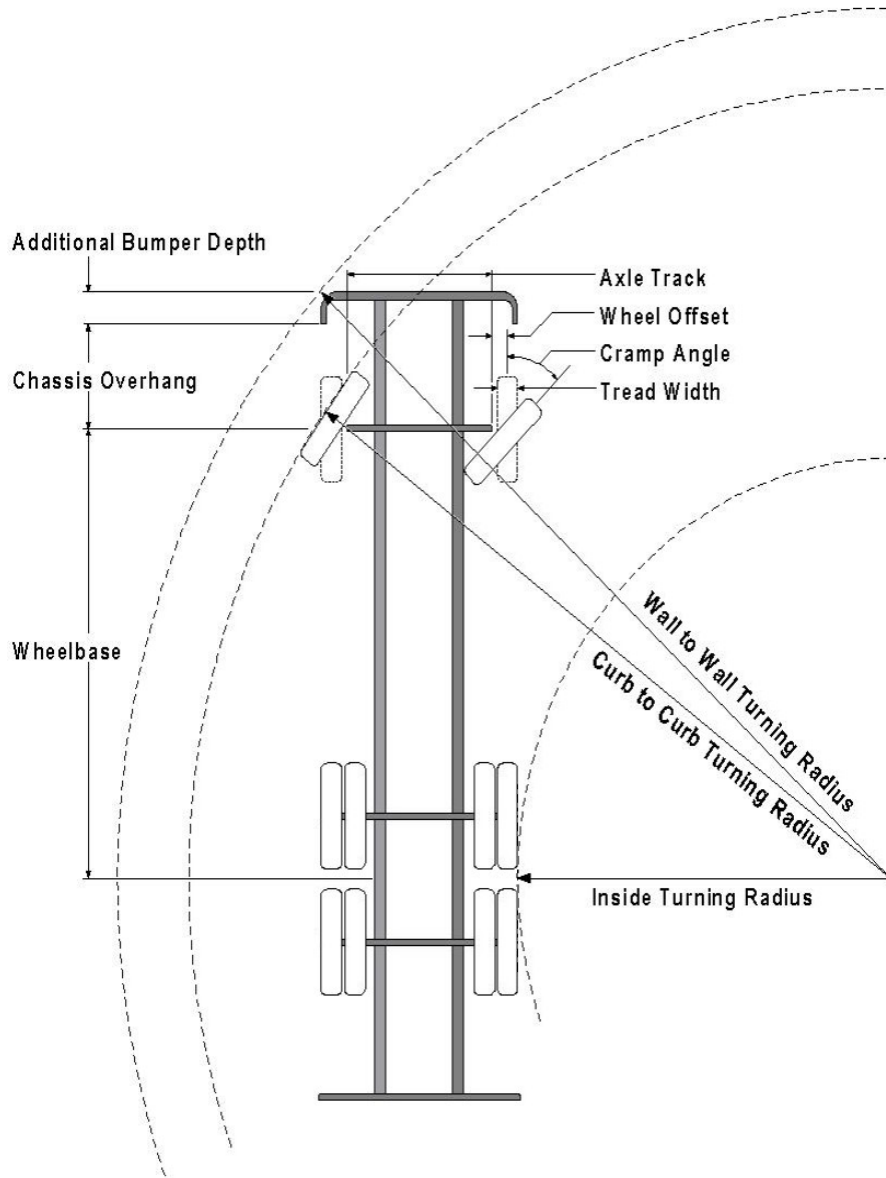
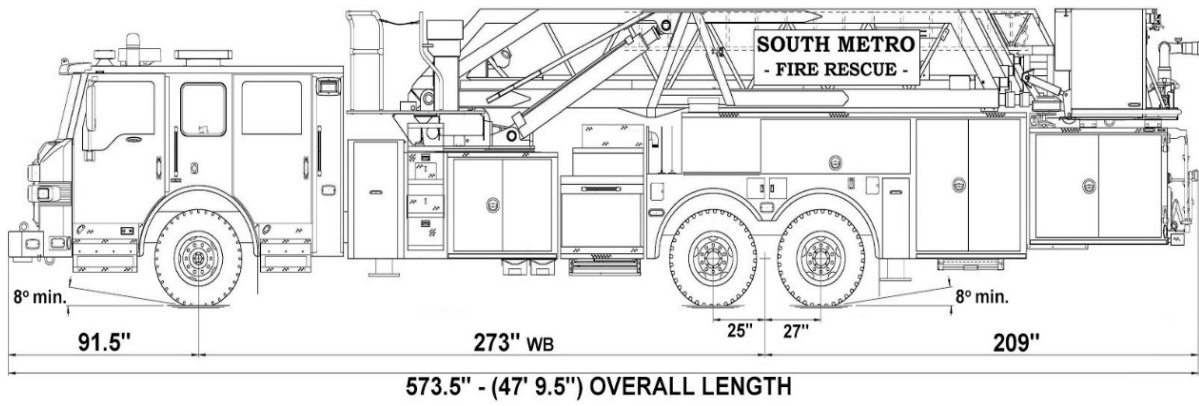

**Vehicle Specifications**

Length: 47' 9.5"

Width: 8' 5" - (10' 1" mirror to mirror)

Height: 10' 9"

Wheelbase: 273 in.

Design load: 80,000 pounds

Inside Cramp Angle: 40°

Axle Track: 83"

Wheel Offset: 5.3"

Tread Width: 13.5"

**Turning Radii:**

Inside Turn: 26 ft. 1 in.

Curb to curb: 41 ft. 11 in.

Wall to wall: 46 ft. 8 in.

**Where objects are present adjacent to the fire apparatus access road, particularly on turns and turn arounds which require backing, a reasonable safety margin shall be provided to prevent potential damage to the property and to the fire apparatus.**

PRIVATE ROADS that provide access to more than two dwellings or one or more commercial buildings shall be constructed to meet the roadway standards approved by the South Metro Fire Rescue Authority for fire apparatus access. Private roads that do not meet the roadway standard may be accepted provided that alternative methods and materials are incorporated into the subdivision that addresses the fire and life safety of the citizens.

**FIRE CODE REVIEW BLOCK**

All fire hydrants shall be installed according to water utility standards. The number and locations of the fire hydrants as shown on the Overall Utility Plan are correct as specified by the Town of Parker, Community Development Department.

\_\_\_\_\_  
Fire Code Official or Designated Representative

\_\_\_\_\_  
Date

(NOTE – Underground Fire Line (UFL) submittal documents must meet the requirements of NFPA 24 when submitting for review.)