

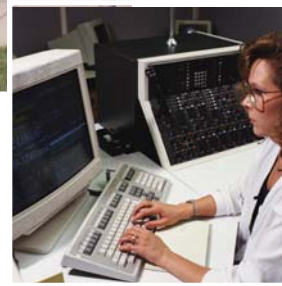

Site Plan Amendment
Approved by:
Carolyn Washee-Freeland, AICP
Associate Planner
Town of Parker, Colorado
Approved: June 15, 2020



Steel Doors and Frames



ASSA ABLOY, the global leader
in door opening solutions

707 SERIES

Specifications

Doors shall be 707 type as manufactured by CURRIES, Mason City, Iowa. Doors are to be manufactured of the finest quality 14, 16, 18, 20 (specify gauge) cold rolled stretcher leveled steel or galvanized steel (specify). All doors shall be full flush construction and either 1-3/4" (44) or 1-3/8" (35) thick. Doors shall be reinforced, stiffened, insulated, and sound deadened with a solid polystyrene foam board permanently bonded to the inside of each face skin. The lock and hinge edge of each door shall be welded with a centered hairline seam the full height of the door (707S) OR both the lock and hinge edge of each door shall be welded, filled and ground smooth (seamless) the full height of the door (707N) OR the lock and hinge edge of each door may have the center seam continuously wire welded the full height of the door, filled and ground smooth (707T). The lock edge shall be reinforced full height by a 14 gauge continuous one piece channel, formed and tapped for hinges. Top and bottom of the door shall be closed with 16 gauge channels. Doors shall have beveled 1/8" (3) in 2" (51) lock edge and square hinge edge. Doors shall be thoroughly cleaned and receive an iron phosphate treatment prior to receiving one coat of prime paint. Minimum hardware reinforcement shall consist of the following: Closers - Overhead Holders - Rim Panics, 14 gauge channels; Butts and Locks as previously specified herein. Floor Closers and Pivots - 7 gauge x template requirements.



NOTE:
#4 stainless steel can be substituted into this specification with 16 ga. faces.

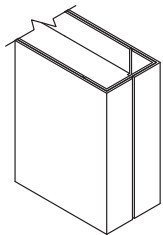
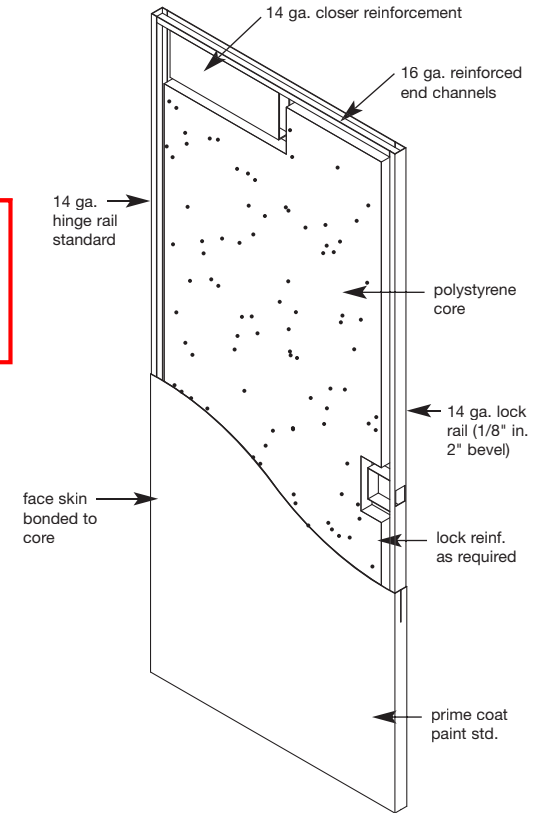

707S
Exposed hairline seam on center of door edge

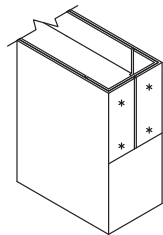

707N
Seam welded, filled and ground smooth.

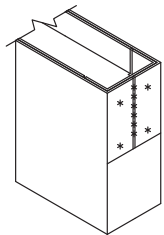

707T
Seam welded, full length and ground smooth.

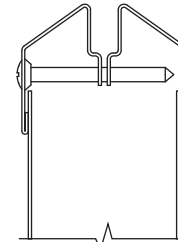

STANDARD GLASS MOLDING

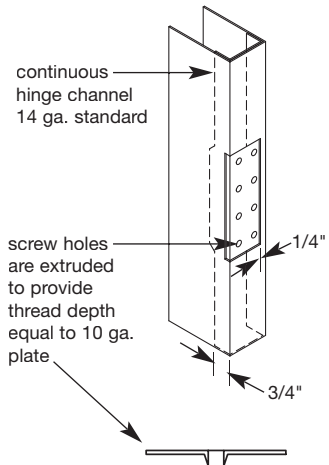

707 SERIES HINGE CHANNEL REINFORCING

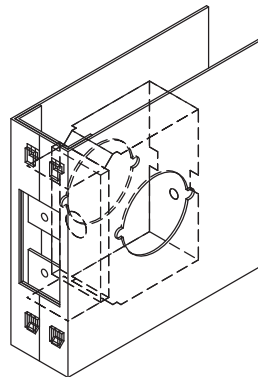

GOVT. 161 CYLINDRICAL LOCK REINFORCEMENT

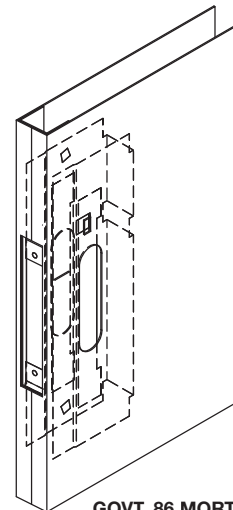

GOVT. 86 MORTISE LOCK REINFORCEMENT

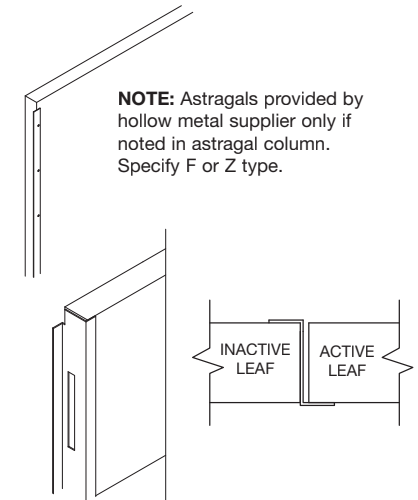

NOTE: Astragals provided by hollow metal supplier only if noted in astragal column. Specify F or Z type.

JOB NO.	PROJECT	LOCATION	SHEET NO.	OF
---------	---------	----------	-----------	----

Masonry/Flush Frames



Site Plan Amendment
Approved by:
Carolyn Washee-Freeland, AICP
Associate Planner
Town of Parker, Colorado
Approved: June 15, 2020

ASSA ABLOY, the global leader
in door opening solutions

Overview

CURRIES offers a complete line of flush frames that are available in 18, 16, 14, and 12 gauge cold-rolled or galvanized steel and in 16 or 14 gauge stainless steel. Frames can be knocked down, set up and spot welded at miters, or set up and arc welded at miters and ground smooth. The 12 gauge frames are saw miter welded or saw butt end welded, corner construction only. They are available for either 1-3/8" (35) or 1-3/4" (44) thick doors. CURRIES frames are manufactured for all wall conditions such as masonry, steel stud, wood stud, and poured concrete.

- Frame face Variables: CURRIES offers pre-engineered, knock-down (KD) flush frames with face dimensions of 1" (25), through 4" (102) in 1/8" (3) increments.
- Frame return variables from 7/16" (11) through 1" (25).
- Non-door rabbet variables from 5/8" (16) through 6" (152).
- Frame sizes available to match door sizes, in any combination of singles or pairs. Non-standard width or height frames are available on special order.

M Series/Jamb Depths

3" (76) to 14" (356), 1/8" (3) Increments

Specifications

Frames shall be M Series as manufactured by CURRIES of Mason City, Iowa. Frames are to be fabricated of either cold-rolled or galvanized steel (as specified) of either 18, 16, or 14 gauge. Joints are to be die-mitered with integral tabs for reinforcement and interlocking of the jambs to the head. 12 gauge frames are saw miter or saw butt end corner construction. Frames shall be knock-down or set-up and welded. Frames shall be thoroughly cleaned and receive an iron phosphate treatment prior to receiving one coat of baked on prime paint. Frames are to be reinforced only for surface mounted hardware, with drilling and tapping to be done in the field by others. Metal plaster guards are to be provided for all mortise cutouts. Minimum requirements for hardware reinforcements are to be as follows: Hinge Reinforcing-7 gauge, Lock

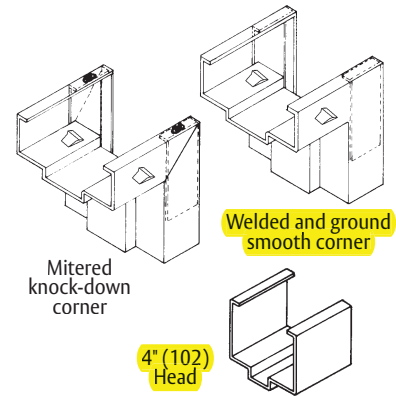

Strike Reinforcing-14 gauge conforming to template requirements and closer reinforcing-14 gauge.

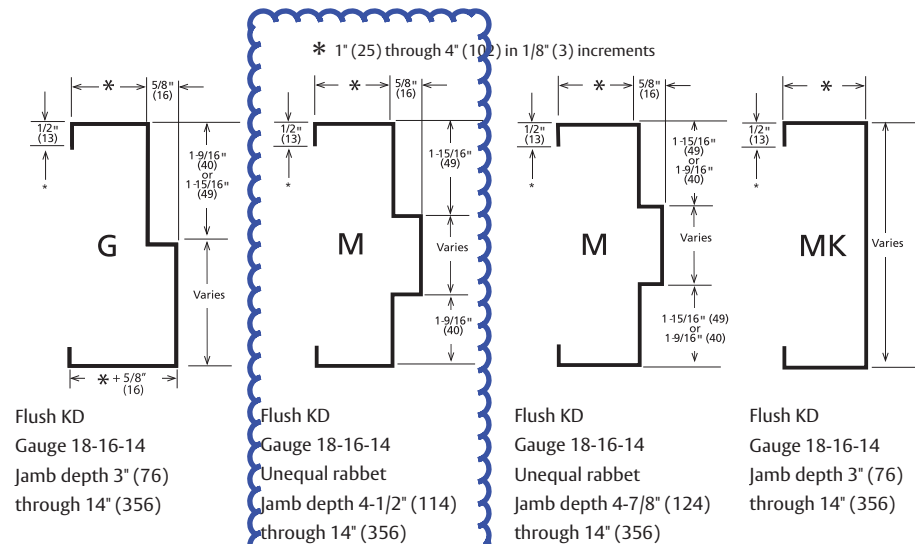

NOTE: 5-3/4" (146) jamb-depth frames have 7/16" (11) back bend.

Anchors

CURRIES offers standard anchors for masonry, wood studs, steel studs, and solid partitions. Anchors are available either loose or welded in.

