



Town of Parker Community Development Department  
 Development Review Division  
 Attention: **Stacey Nerger**

Application Type: **Site Plan**  
 Status: **First Referral**  
 Application Name: **Parker and Pine F1 L2 - Gas Station & Conv. Store**  
 Case/AP#: **SP20-0019**  
 Referral Received: April 8, 2020  
 Comments Due: May 6, 2020

Application Location: Southwest corner of Parker Road and Pine Drive

Review date: **April 27, 2020**  
 Plan reviewer: **Randall L. Capra, [rcapra@parkeronline.org](mailto:rcapra@parkeronline.org)**  
 Phone: 303.805.3169

**Narrative:** The applicant, Murphy USA, is proposing a Site Plan for a 2,824 sq. ft. gas station/convenience store for Murphy Express. The site is located at the southwest corner of Parker Road and Pine Drive.

**Code Reference:** 2018 International Fire Code, 2018 International Building Code

<b>TOWN OF PARKER - FIRE/LIFE SAFETY:</b>	<b>R REVIEWED FOR CODE COMPLIANCE; REVISIONS REQUIRED</b>
---	---

- 1<sup>st</sup> Submittal – Reviewed April 27, 2020
- 2<sup>nd</sup> Submittal – Reviewed July 28, 2020 (*Comments in red, italicized font*)
- 3<sup>rd</sup> Submittal – Reviewed November 23, 2020 (*Comments in bold, red, italicized font*)

**UNRESOLVED ISSUES/COMMENTS**

1. The applicant shall be aware that no vertical construction on this site will be allowed until such time that curb gutter and first lift of asphalt are installed; a site inspection will be required to ensure that this requirement is made prior to allowing vertical construction to commence. *Satisfied; applicant has acknowledged that they will comply with the second submittal.*
  
2. Per the requirements of [18 IFC Section 503.1.1 Buildings and Facilities] approved fire apparatus access roads shall be provided for every facility, building, portion of a building hereafter constructed or moved into or within the jurisdiction. The fire apparatus access road shall comply with the requirements of this section and shall extend to within 150 feet of all portions of the facility and all portions of the exterior walls of the first story of the building as measured by an approved route around the exterior of the building or facility (the building is a 155+ feet long and 50.56 feet wide and cannot meet the requirement as measured from the center line of the fire apparatus as measured by an approved route from any point that a fire engine might park when responding to a call at this building). This submittal does not provide for this requirement of the code. Per the requirements of the code, the fire code official is allowed to increase the dimension of the 150 feet provided that the applicant meets Exception 1.1 of this section... "The building is equipped throughout with an approved automatic sprinkler suppression system installed in accordance with section 903.1.1, 903.1.2, or 903.3.1.3. *The applicant has indicated that they are unsure whether this comment is applicable; the comment is very much applicable. The private drives will not be utilized (except for a catastrophic response and Parker Road will never be used for emergency response. This would then indicate that the applicant is required to provide access internally. The applicant was given this information so as to they can meet this requirement, fully. To further help the applicant understand this question, working off of internal roads can create access issues with regard to getting additional apparatus onto the site as well as getting civilians off the site... as well as redeploying apparatus as they come in service.*

*For the applicant's clarity, I have provided a marked up site plan to address the crucial elements of this site; access, as shown, must be provided at all times.*

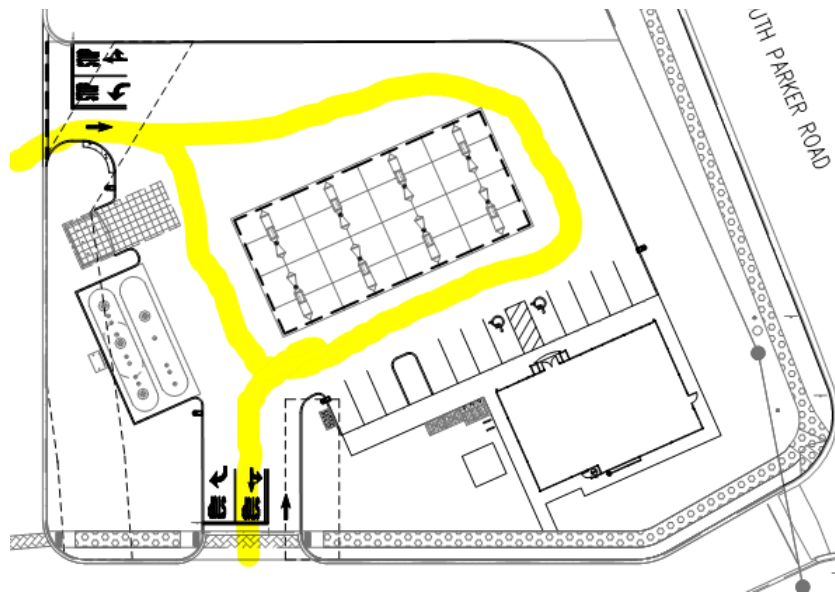

**Satisfied; applicant has addressed with current submittal. Applicant has provided the auto-turn analysis and provided associated fire lane signage.**

3. The applicant shall provide an auto turn analysis indicating that apparatus can navigate all portions of this site (both sides of the gas canopy); NO PARKING – FIRE LANE signage is required for any portion of the access where the 20-foot clear width requirement cannot be met. This is applicable for the loop around the canopy as well as for each entry. The access on each side of the canopy shall meet his requirement with no portion of the canopy encroaching into the required fire lane access road. **Partially satisfied; applicant has addressed with current submittal. Note – the applicant has provided a Fire Life Safety signature block on the sheet C-1.2 (Fire Mobility Plan); the applicant shall be aware that Fire Life Safety will only sign the signature block on the two sheets specified for the utility drawings. This signature block should be removed. Satisfied; applicant has addressed with current submittal. Applicant has provided the auto-turn analysis and provided associated fire lane signage.**
4. The Town of Parker requires that fire apparatus access roads meet the clear-width and weight-bearing standards of the jurisdiction in which the project is located. Roadways shall be designed to support the imposed weight of fire apparatus, 30 two axle and 40 ton three axle vehicles. An unimpeded clear width of 20 feet shall be maintained at all times. As such, any location where parked vehicles would obstruct this clear width requirement will require “NO PARKING – FIRE LANE” signage. **This signage shall be red on white. Update design criteria has been provided at the end of this document; ensure compliance when resubmitting. Not satisfied; applicant has indicated that “the area has been designed to withstand heavy vehicular traffic (fueling trucks)” without really answering the requirement. A 30-ton vehicle is “heavy” but does not meet the requirement noted. It is immaterial whether “fueling trucks” will be using the site. The applicant shall document that the access will be designed to meet the imposed weights noted above when resubmitting. Satisfied; applicant has addressed with current submittal. Applicant has documented that the site will support the weight bearing requirements of fire apparatus as noted.**
5. The applicant shall provide a fire hydrant in the island shown below; address this issue when resubmitting. **Satisfied; applicant has addressed with current submittal.**

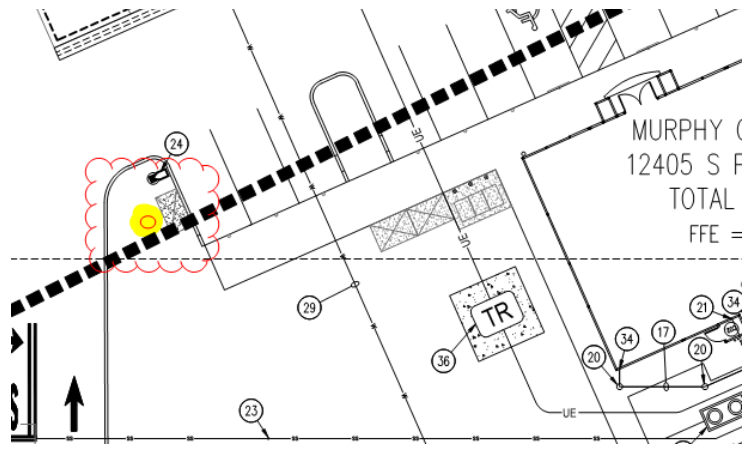

- 6. The applicant has not included the required fire life safety signature block for Fire Life Safety on either a cover page or the overall utility page. This issue must be addressed when resubmitting. *Satisfied; applicant has addressed with current submittal. The applicant has added the signature blocks as required.*

Note - An updated signature block has been created with regard to the utility drawing package; typically, this signature block is located on the cover sheet and the overall utility page of the water drawings. The signature block is noted below; address as applicable.

**GENERAL COMMENTS (as applicable)**

All engineering documents submitted to the Town of Parker shall bear the wet signature and seal of the engineer or architect in responsible charge of the design.

Water distribution and site access components shall be installed and in service prior to the construction of any portion of the structure, except by special permit issued by the Fire District.

**Underground fire lines**

When thrust blocks are used as part of the pipe restraint system, submitted plans for permit shall provide detailed documentation that the thrust blocks satisfy all requirements of 13 NFPA 24: 10.8.2, including specific thrust block dimensions and mathematical calculations for block dimensions per guidelines provided in Annex A.10.8.2.

**FIRE CODE REVIEW BLOCK**

All fire hydrants shall be installed according to water utility standards. The number and locations of the fire hydrants as shown on the Overall Utility Plan are correct as specified by the Town of Parker, Community Development Department.

\_\_\_\_\_  
Fire Code Official or Designated Representative

\_\_\_\_\_  
Date

(NOTE – Underground Fire Line (UFL) submittal documents must meet the requirements of NFPA 24 when submitting for review.)

**FIRE ACCESS ROAD DESIGN CRITERIA**

**VEHICLE SPECIFICATIONS** are provided for the largest apparatus in use by South Metro Fire Rescue. Fire Apparatus Access Roads shall be capable of accommodating this apparatus.

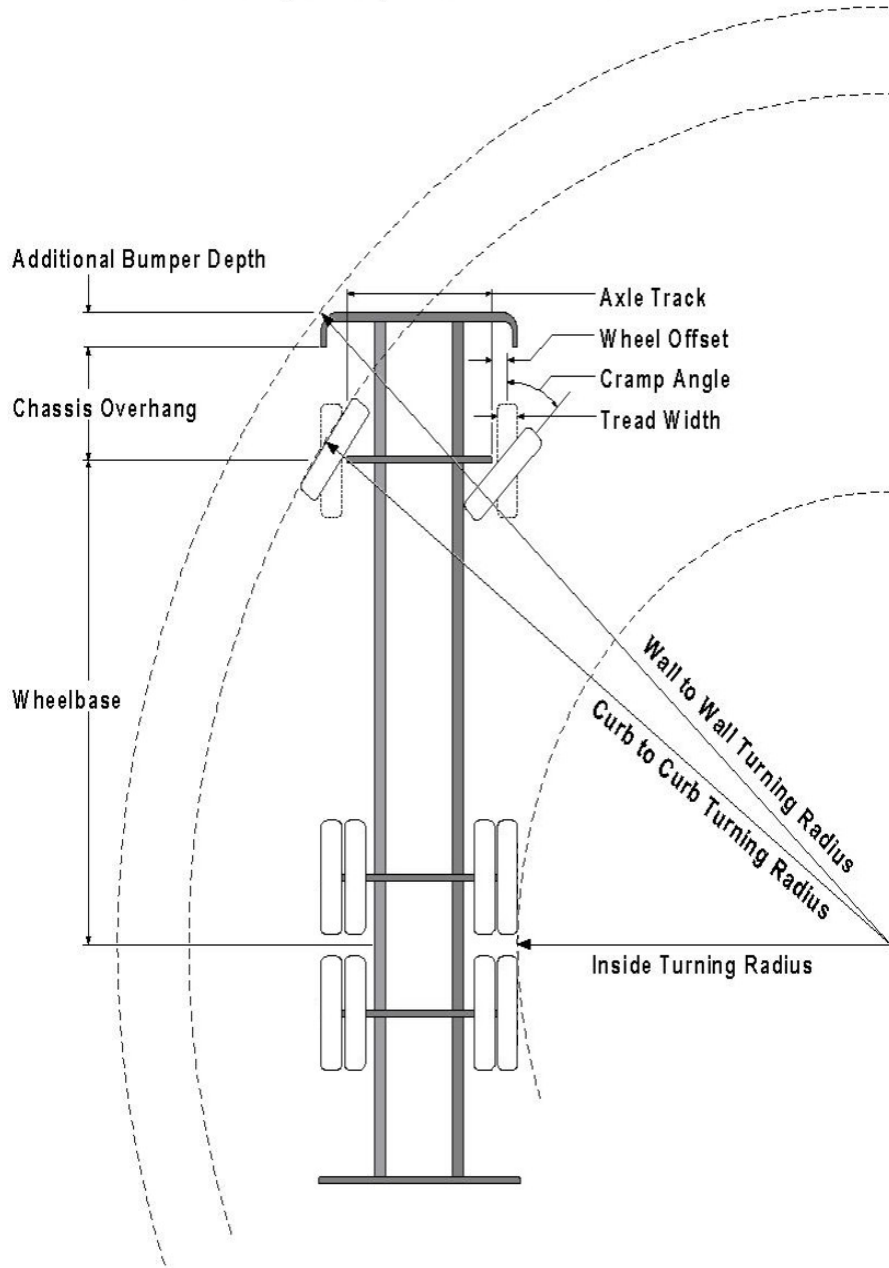
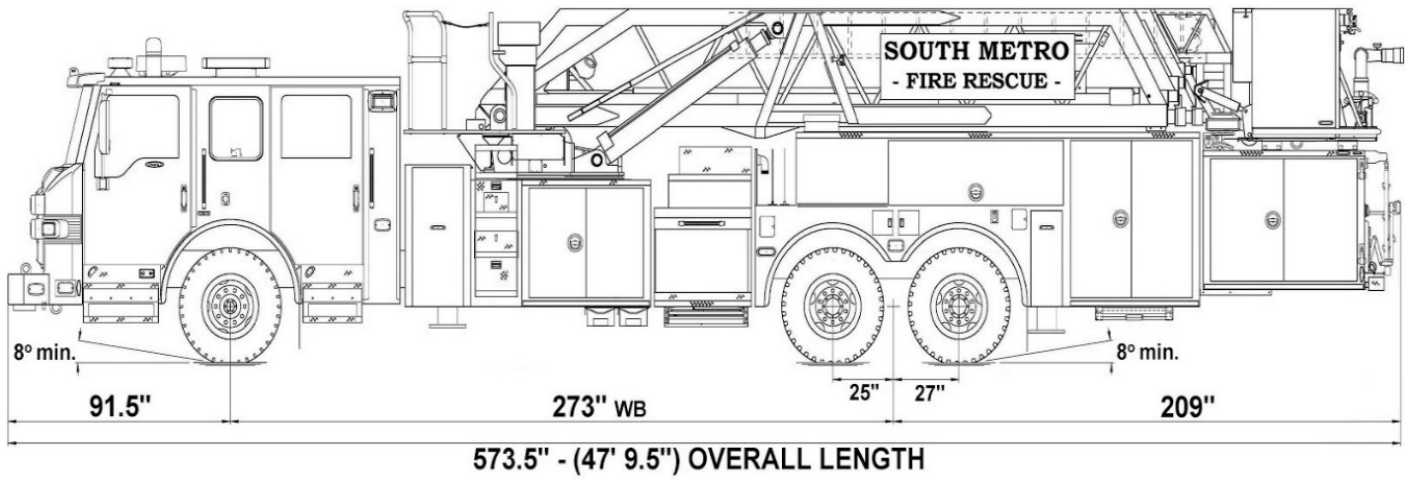

## Vehicle Specifications

Length: 47' 9.5"

Width: 8' 5" - (10' 1" mirror to mirror)

Height: 10' 9"

Wheelbase: 273 in.

Design load: 80,000 pounds

Inside Cramp Angle: 40°

Axle Track: 83"

Wheel Offset: 5.3"

Tread Width: 13.5"

## Turning Radii:

Inside Turn: 26 ft. 1 in.

Curb to curb: 41 ft. 11 in.

Wall to wall: 46 ft. 8 in.

**Where objects are present adjacent to the fire apparatus access road, particularly on turns and turn arounds which require backing, a reasonable safety margin shall be provided to prevent potential damage to the property and to the fire apparatus.**

PRIVATE ROADS that provide access to more than two dwellings or one or more commercial buildings shall be constructed to meet the roadway standards approved by the South Metro Fire Rescue Authority for fire apparatus access. Private roads that do not meet the roadway standard may be accepted provided that alternative methods and materials are incorporated into the subdivision that addresses the fire and life safety of the citizens.

## Underground Fire Line - Submittal Requirements

Reference: 2013 NFPA 24 [Installation of Private Fire Service Mains and Their Appurtenances](#)

A separate permit is required and will be issued pending review of a detailed submittal which must include the following:  
[15 IFC 901.2]

4.1.1 Working plans shall be submitted for approval to the authority having jurisdiction before any equipment is installed or replaced.

4.1.2 Deviation from approved plans shall require permission of the authority having jurisdiction.

4.1.3 Working plans shall be drawn to an indicated scale on sheets of uniform size, with a plan of each floor as applicable, and shall include the following items that pertain to the design of the system:

- (1) Name of owner
- (2) Location, including street address
- (3) Point of compass
- (4) A graphic representation of the scale used on all plans
- (5) Name and address of contractor
- (6) Size and location of all water supplies
- (7) The following items that pertain to private fire service mains:
  - (a) Size
  - (b) Length
  - (c) Location
  - (d) Material (ductile-iron, PVC., etc.)
  - (e) Point of connection to city main

- (f) Sizes, types, and locations of valves, depth at which the top of the pipe is laid below grade
- (g) Method of restraint (Meg-a-Lug or similar)

4.1.4 The working plan submittal shall include the manufacturer's installation instructions for any specially listed equipment, including descriptions, applications, and limitations for any devices, piping, or fittings. Submittals must include installation specifications for thrust blocks, corrosion protection, restraint system, bedding, detail of pipe under the building up to, and including, the flange. When it is intended that a different contractor will extend the fire line from a stopping point outside the building, to the inside flange, a second submittal and permit is required.

**All tees, plugs, reducers, valves, and hydrant branches shall be restrained against movement by thrust blocks [10.8.2] or restrained joint systems [10.8.3]. When thrust blocks are used as part of the pipe restraint system, submitted plans shall provide detailed documentation that the thrust blocks satisfy all requirements of Section 10.8.2, including specific thrust block dimensions and mathematical calculations for block dimensions per guidelines provided in Annex A.10.8.2.**

Any individual or company who physically works on or installs any part of a fire suppression system, including underground supply lines, from public water lines to system risers and backflow preventers, **must** be registered with the Colorado Division of Fire Safety. [Dept of Public Safety, Division of Fire Safety, Fire Suppression Program 8 CCR 1507-11:3.1.2] Documentation of valid annual registration may be required with plan submittal.

The following website for the Colorado Division of Fire Safety will provide registration instructions.

<http://dfs.state.co.us/SuppAppsProclnsp.htm>

All submittals must display a wet stamp and original signature by a Colorado licensed professional engineer or NICET III, or higher, in fire suppression systems. [Dept of Public Safety, Division of Fire Safety, Fire Suppression Program 8 CCR 1507