

# **INTERMOUNTAIN RURAL ELECTRIC ASSOCIATION**

## **Builder/Developer Service Requirements**



**Revised May 2019**

# **WELCOME TO INTERMOUNTAIN RURAL ELECTRIC ASSOCIATION**

We understand that obtaining electrical facilities is only one of many tasks our customers must achieve during the construction of a new residence or commercial facility. Therefore, it is our goal to provide the best customer service possible.

Please do not hesitate to contact our Engineering Services Department with any questions or concerns at 303-688-3100, ext. 5302.

Providing us with the *work request (WR#)* number or description of the property will help us answer your questions promptly.

We look forward to serving you!

## Table of Contents

PROCESSING NEW SERVICE APPLICATIONS.....	4
Phase 1 – Engineering.....	4
Phase 2 – Contract and Construction .....	5
ELECTRIC SAFETY AND CODE CLEARANCES.....	6
LOCATES FOR UNDERGROUND UTILITIES .....	7
RIGHT-OF-WAY, EASEMENTS, AND ACCESS .....	8
Types of Easements .....	8
Access to Utility Easements.....	8
General Restrictions on Easements/Right-of-Way.....	8
Landscaping on Utility Easements (Working Space).....	9
Single-phase Pad Mounted Equipment.....	10
Three-phase Pad Mounted Equipment.....	11
Pad Mounted Switchgear .....	14
Commercial EUSERC Cabinets.....	15
Guard Posts for Pad Mounted Equipment.....	16
TEMPORARY POWER SERVICES .....	18
Temporary Overhead Power Source .....	18
Temporary Underground Power Source .....	20
Temporary CT Metering .....	23
RESIDENTIAL POWER SERVICES (Single Lot, Multi-Family and Development) .....	23
Street Lighting.....	23
Joint-Trench .....	24
Meter Sets .....	24
Choosing the Right Service Voltage.....	25
Meter Locations.....	25
Service Laterals (installed by Association).....	32
Multiple Meter Installations.....	34
Specifications for Single-Phase 120/240V 3-Wire Meter Housings.....	37
Additional Requirements for 1Ø Underground Feed Residential Meter Housings.....	38

Additional Requirements for 120/208V 1Ø Hookups.....	38
Fault Current Levels and Standard KVA Size Transformers.....	38
COMMERCIAL/INDUSTRIAL POWER SERVICES.....	40
Street Lighting.....	40
Joint-Trench.....	40
Meter Sets.....	40
Meter Locations.....	41
Multiple Meter Installations.....	47
Cable Limits for Three-Phase Pad-Mounted Transformers.....	49
Fault Current Levels and Standard KVA Size Transformers.....	49
Specifications for Single & Three-Phase Self-Contained Meter Housings (120/240V 1Ø, 3-Wire; 120/208V, 3Ø, and 277/480V 3Ø 4-Wire).....	51
Specifications for Meter Location and Installation.....	52
Three-Phase Services: 120/240V, Four-Wire Delta.....	54
Three-Phase Self- Contained Services: 277/480V.....	54
Three-Phase Services, Above 200 Amps.....	56
Manufacturer Drawings Required for Services Over 200 Amps.....	56
CURRENT TRANSFORMER (CT) / POTENTIAL TRANSFORMER (PT) METERING.....	57
GLOSSARY.....	67
DRAWING LIST.....	69
SMALL GENERATION INTERCONNECTION – <a href="http://www.irea.coop/rates-renewables">www.irea.coop/rates-renewables</a>	

## PROCESSING NEW SERVICE APPLICATIONS

---

There are two separate phases in the processing of each new service application. Each of the two phases requires that the applicant complete certain steps. This may involve supplying information about the requirements for electric service to the Association or completing certain actions at the construction site. In all cases, a delay in providing information needed for engineering or construction will delay the availability of electric service. Therefore, it is important that information is provided as needed, and all steps are completed as quickly as possible. This guideline is provided to assist the applicant with this process. Some requests may have unusual aspects not specifically described here.

### Phase 1 – Engineering

Initial contact with the Association will open a work order, which identifies the owner as an applicant for new service. The information required in STEP 1 may be provided by phone, email, fax, or in person at our office. A *Contract Authorization* form will be submitted to the applicant requesting the items listed within STEP 1. Upon receipt of the completed and signed *Contract Authorization* with proof of ownership and payment of the design fee, the work order will be released to engineering for assignment.

#### STEP 1

- Owner name to appear on all accounts
- Owner's current mailing address
- Street address of property, if available
- Legal description of property to which service is required
- Owner/builder telephone numbers, fax numbers, email, etc.
- Overhead or underground service requirement
- Payment of applicable design fee
- Proof of ownership (Warranty Deed, Property Tax Statement, etc.)
- Any distributed generation (solar, wind, etc.) interconnection requirements.

For commercial, industrial, and large residential services:

- Copy of engineered electric one-line diagram and panel schedules
- Copy of site plan, drainage, grading and utility site plan - CADD format
- Total electric demand (kW)
- Largest motor(s) and type of motor starting to be used
- Size and quantity of service entrance conductors

The engineer will contact the applicant at the phone numbers provided and arrange an on-site meeting to discuss the service requirements and explain the Association's policy and procedures. During the on-site meeting, the applicable items in STEP 2 will be discussed. Be prepared to show plans and drawings to the engineer. A recorded plat of the property may be required. It may be necessary for the applicant to obtain right-of-way if the routing of the power line crosses a property on which the Association does not have an easement. The engineer will instruct the applicant in this regard, when necessary. The engineer will design, route, and stake the line extension at that time or later in certain situations.

## **STEP 2**

- Survey/location of property pins, including corner, points of line and road right-of-way, as required
- Location of well, septic system, and leach field
- Location of driveway or other access
- Location of structures
- Location of the meter
- Electric service requirements: voltage, amp size, phase
- Right-of-way acquisition
- Recorded Plat

## **Phase 2 – Contract and Construction**

When the design is complete, the engineer will contact the applicant with an estimated cost and copy of construction print for review. A construction contract will be sent to the applicant. The estimated cost is valid for a period of 60 days. After that time, or if redesigns are required, payment of an additional design fee may be required. The items shown within STEP 3 are required before a job can be released for construction. .

## **STEP 3**

- Signed construction contract
- Payment of total amount due
- Signed and notarized rights-of-way, if required
- Payment of outstanding balances on other accounts, if any
- Posting of the street address or addresses on the property

Following construction of distribution facilities, the Association will set a meter in accordance with the stipulations shown in STEP 4. Typically, the meter can be set within three to ten working days following the receipt of the inspector's approval of the temporary or permanent meter inspection. Other permitting requirements may apply to some jobs.

## STEP 4

- Establishment of a billing account per each metered location
- Meter loop constructed to current Association specifications
- Meter loop constructed in location approved by the Association
- Meter inspection approved by the Electrical Inspector
- Service order issued to set meter and energize service

## ELECTRIC SAFETY AND CODE CLEARANCES

---

It is the policy of the Association to operate the transmission and distribution electric system with the highest degree of care and safety for the public and Association employees. To ensure the care and safety needed for an electrical distribution system, the National Electrical Safety Code (NESC) is used for design, construction, maintenance, and operation of the electrical transmission and distribution system by the Association. The current National Electrical Safety Code in effect at the time of distribution installation will apply. The Association reserves the right to terminate service without prior notice when hazardous conditions exist.

Contact with electric lines can result in SEVERE INJURY OR DEATH! Federal OSHA standards and Colorado State Statutes require that all equipment be maintained at a minimum distance of ten feet (20') from 12.47kV and twenty feet (20') from transmission overhead lines.

If work near an overhead electric line is anticipated, contact the Association Operations Department at (303) 688-3100 at least 24 hours in advance for assistance in avoiding contact with any energized facilities.

Any attachments to existing facilities that may violate the minimum clearances as determined by the National Electrical Safety Code must be reported ninety (90) days prior to attaching to the Association's facilities by contacting the Association Engineering Department at (303) 688-3100, ext. 5302.

To comply with NESC requirements, easement and right-of-way grades cannot be changed more than six inches (6") by excavation or filling without prior written approval of all utility companies involved. Full cost of any necessary alteration or relocation of utility lines will be borne by the customer requesting the change.

If a violation has already occurred and the Association determines that relocating the existing facilities is necessary, the Association will perform this relocation at the expense of the property owner or party creating the violation.

If the Association determines that relocation is not feasible, other alternatives will be considered; however, the Association will take the steps necessary to protect the safety of the public and the electric facilities at the expense of the party creating the clearance violation.

Maps of Association facilities are not generally provided to the public. If necessary for engineering, the landowner may request a copy of Association map(s) upon proof of ownership.

## LOCATES FOR UNDERGROUND UTILITIES

---

### **CALL BEFORE YOU DIG! 1-800-922-1987 or 811**

- Contact the Utility Notification Center by dialing 811 or visit [www.uncc.org](http://www.uncc.org), before you dig.
- Trained service personnel will locate the Association's underground electric facilities at no cost.
- **Customer owned underground facilities will require a private locating service at the requestor's expense.**
- Do not start grading or excavation work until all underground facilities have been located.

**CALL UTILITY NOTIFICATION  
CENTER OF COLORADO  
1-800-922-1987 or 811  
CALL 3 BUSINESS DAYS IN ADVANCE  
BEFORE YOU DIG, GRADE, OR EXCAVATE  
FOR THE MARKING OF UNDERGROUND  
ASSOCIATION UTILITIES.**

## RIGHT-OF-WAY, EASEMENTS, AND ACCESS

---

### Types of Easements

The Association generally uses two types of easements:

- A platted/dedicated easement is provided to the Association by virtue of a dedication statement for every platted subdivision. A five-foot (5') side lot and ten-foot (10') rear lot easement are typical platted easements. In some cases a front lot design will require a dedication of ten-foot (10') easement on the front lot. However, if the subdivision is served by overhead facilities or if larger easements are necessary, the Association will require additional easements.
- The Association requires the customer to grant, at no cost to the Association, easements for power lines and any associated equipment prior to installation of any Association facilities. In the event the Association has to cross property other than that of the customer requesting service, the new customer will be required to obtain all easements. Please note that all easements require a legal survey to be provided for documentation.

### Access to Utility Easements

Periodically the Association may need to access facilities within the utility easement. Therefore, the Association requires reasonable access to facilities. To access facilities, the Association may use existing roads, driveways and entrance thru fenced yards.

### General Restrictions on Easements/Right-of-Way

- To comply with NESC requirements, easement and right-of-way grades cannot be changed more than six inches (6") by excavation or filling without prior written approval of all utility companies involved. Full cost of any necessary alteration or relocation of utility lines will be borne by the customer requesting the change.
- Fences and landscaping may be installed on utility easements, except where such materials would prevent access to utility lines or conflict with utility equipment.
- Permanent structures or buildings are not allowed within the utility easement, below the Association's overhead conductors, or above the Association's underground cables.

## Landscaping on Utility Easements (Working Space)

- *Call the Utility Notification Center, toll-free, 1-800-922-1987 or 811, prior to digging.*
- Permanent structures cannot be constructed on utility easements. However, landscaping within an easement is permissible. A minimum clearance is required around all vaults and pad mounted equipment. A distance of 10 feet must be kept clear in front of all service doors. Equipment side clearances vary from 1 to 3 feet.
- Trees should be planted far enough away from pad mounted equipment so that, at maturity, overhanging branches will not obstruct a crane setting or removing equipment. It is best to select trees with supple branches that can be tied back without risk of breaking.
- Responsibility for upkeep and any landscaping maintenance in a utility easement is borne by the property owner/customer.
- In the event a fence must be removed by the Association to repair or maintain electrical facilities, reasonable effort will be made to replace existing fencing when repairs are completed.
- Landscaping, fences, and other obstructions shall not encroach upon the working space clearances.
- A clear and level working space shall be equal to the full width of the equipment and shall extend a minimum of 10 feet from the compartment opening for pad mount equipment.

## Single-phase Pad Mounted Equipment

- Single-phase pad mounted equipment shall have a minimum of 1'-6" of clear working space on the sides and rear of the equipment, and 10' in front of the equipment.

PLAN VIEW OF SINGLE-PHASE PAD MOUNTED EQUIPMENT  
WORKING SPACE AND LANDSCAPING CLEARANCES

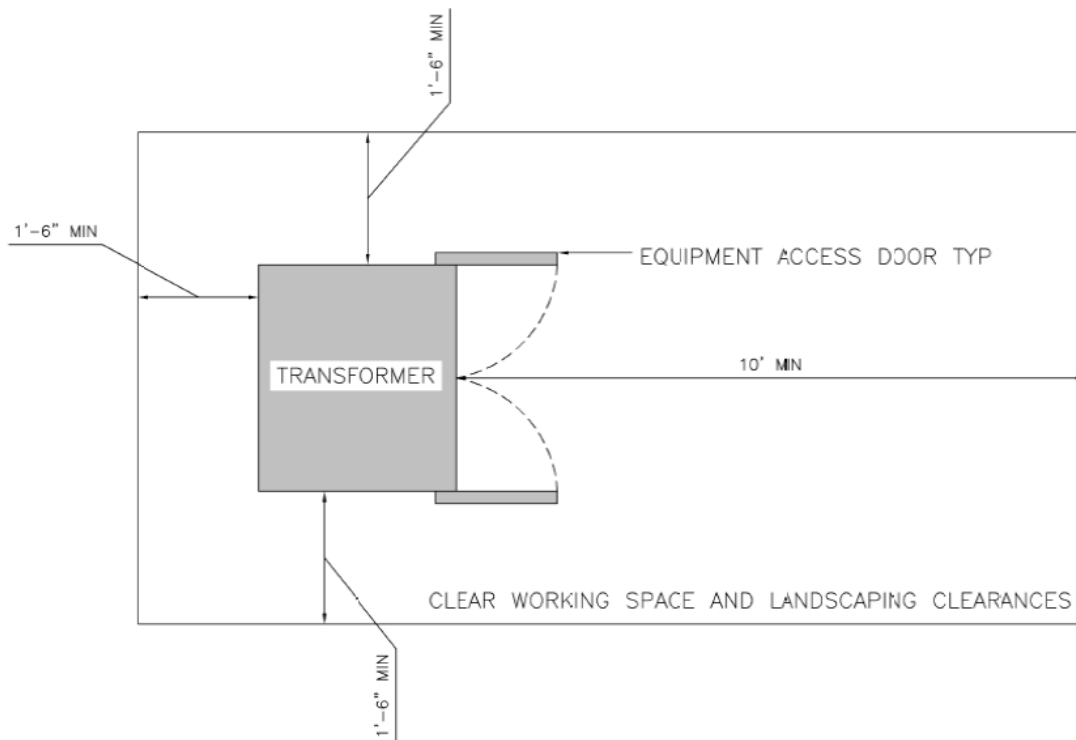

### Three-phase Pad Mounted Equipment

- Three-phase pad mounted equipment with cooling fins shall have a clear working space minimum of 1'-6" on the sides, 2'-6" at the rear of the equipment, and 10' in front of the equipment.

#### PLAN VIEW OF THREE-PHASE PAD MOUNTED EQUIPMENT WORKING SPACE AND LANDSCAPING CLEARANCES

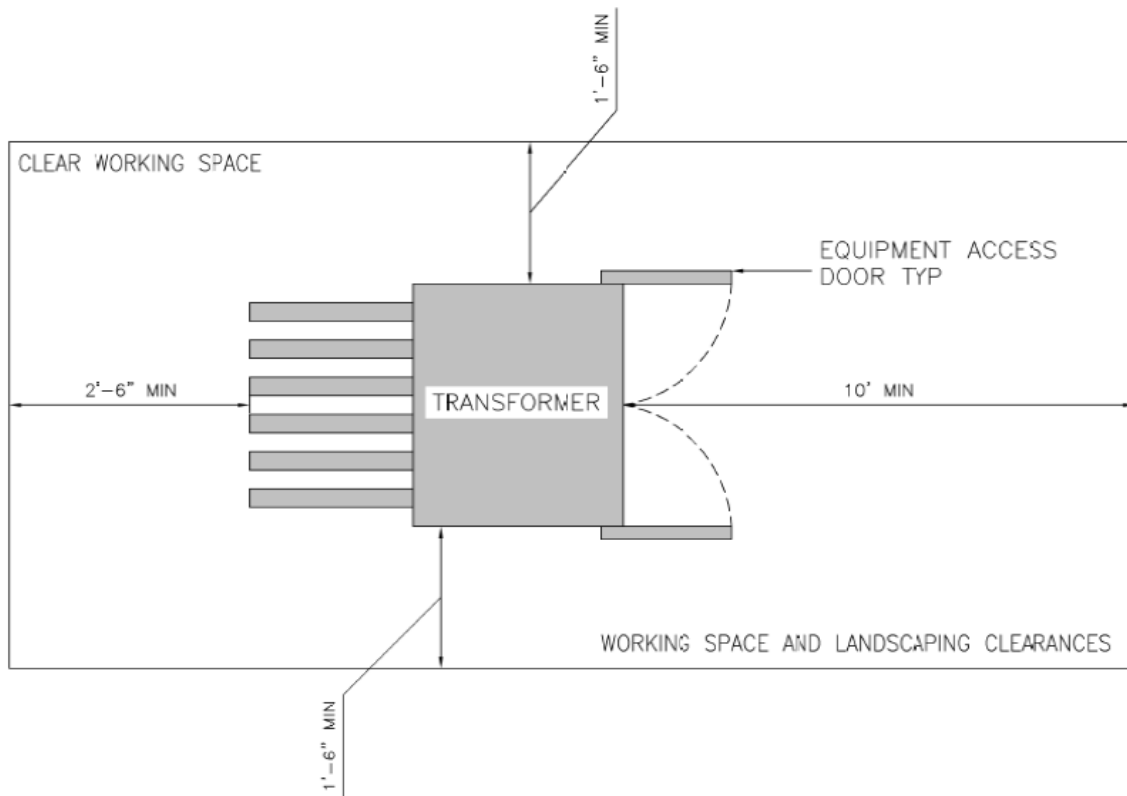

## PAD-MOUNTED TRANSFORMER LOCATION MAP AND MINIMUM CLEARANCES

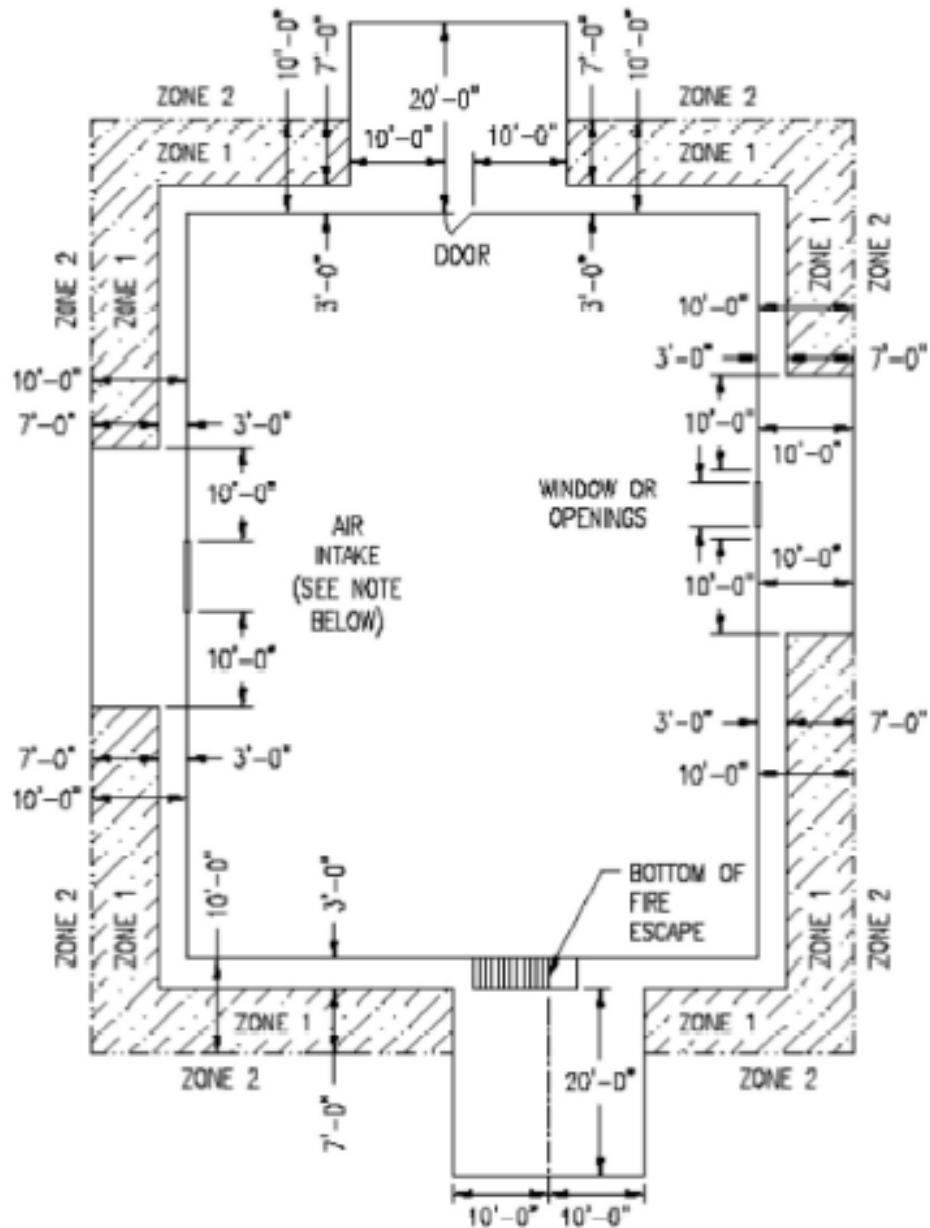

**NOTES:**

- ZONE 1 (Shaded Area) = Minimum distance for pad-mounted transformer from a non-combustible building.
- ZONE 2 = Minimum distance for pad-mounted transformers from a combustible building.
- Air intake clearance must be a minimum of 25 feet diagonal from transformer (not shown), additional clearances are shown on Minimum Distances for Pad-Mount Transformers drawing.

## MINIMUM DISTANCES FOR PAD-MOUNT TRANSFORMERS

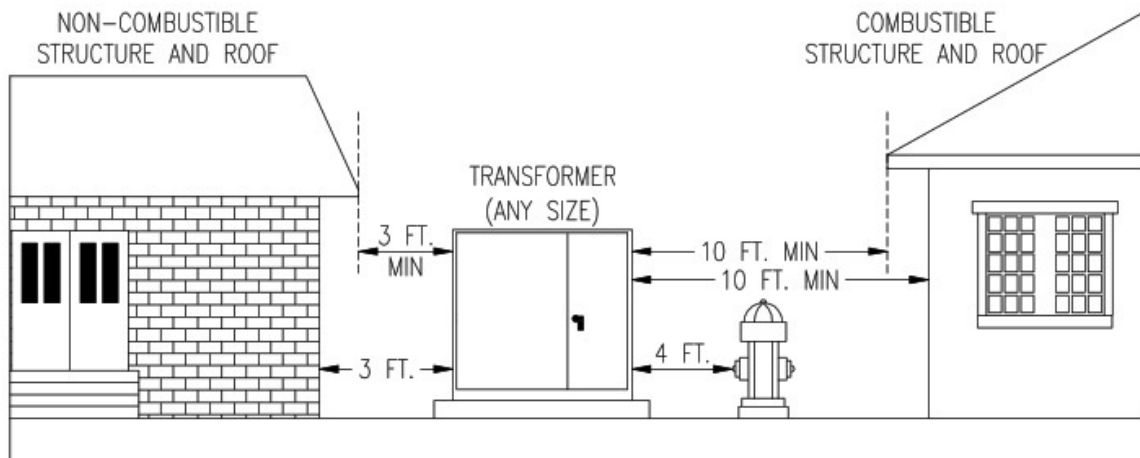
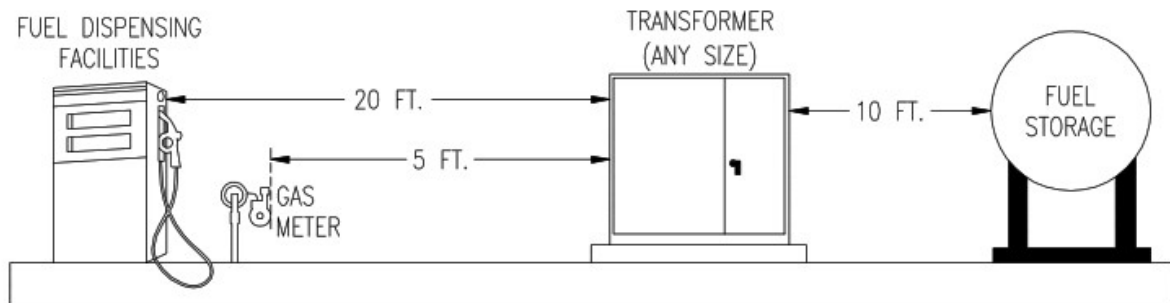
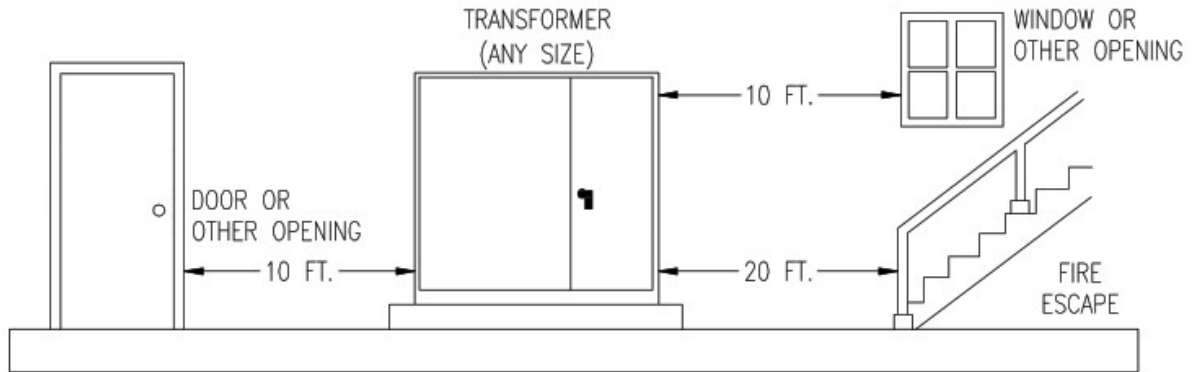

NOTE: THE MINIMUM SEPARATION DISTANCES SHOWN MAY NOT MEET INSURANCE PROPERTY LOSS PREVENTION REQUIREMENTS. BUILDER/DEVELOPER IS RESPONSIBLE FOR CONFIRMING THESE MINIMUM SEPARATION DISTANCES AND INFORMING IEA ENGINEERING PRIOR TO CONSTRUCTION IF ADDITIONAL CLEARANCES ARE NEEDED.

## Pad Mounted Switchgear

- Pad mounted air switchgear shall have a minimum clear working space of 3' on the sides of the equipment, and 10' in front and rear of the equipment.

### PLAN VIEW OF PAD MOUNTED SWITCHGEAR WITH DOORS ON BOTH SIDES WORKING SPACE AND LANDSCAPING CLEARANCES

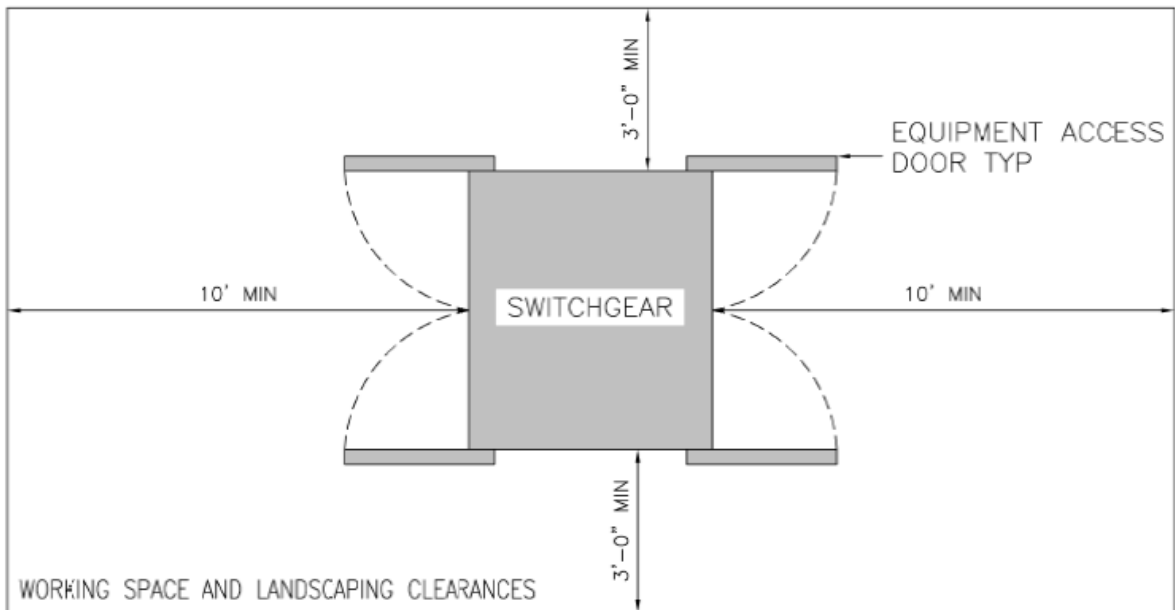

## Commercial EUSERC Cabinets

- Commercial EUSERC Cabinets shall have a minimum of 3' clear, level space beyond the door when fully open at 90-degree position. This equipment is typically placed parallel to the building wall.

### PLAN VIEW COMMERCIAL MULTI-METERING EUSERC CABINET WORKING SPACE AND LANDSCAPING CLEARANCES

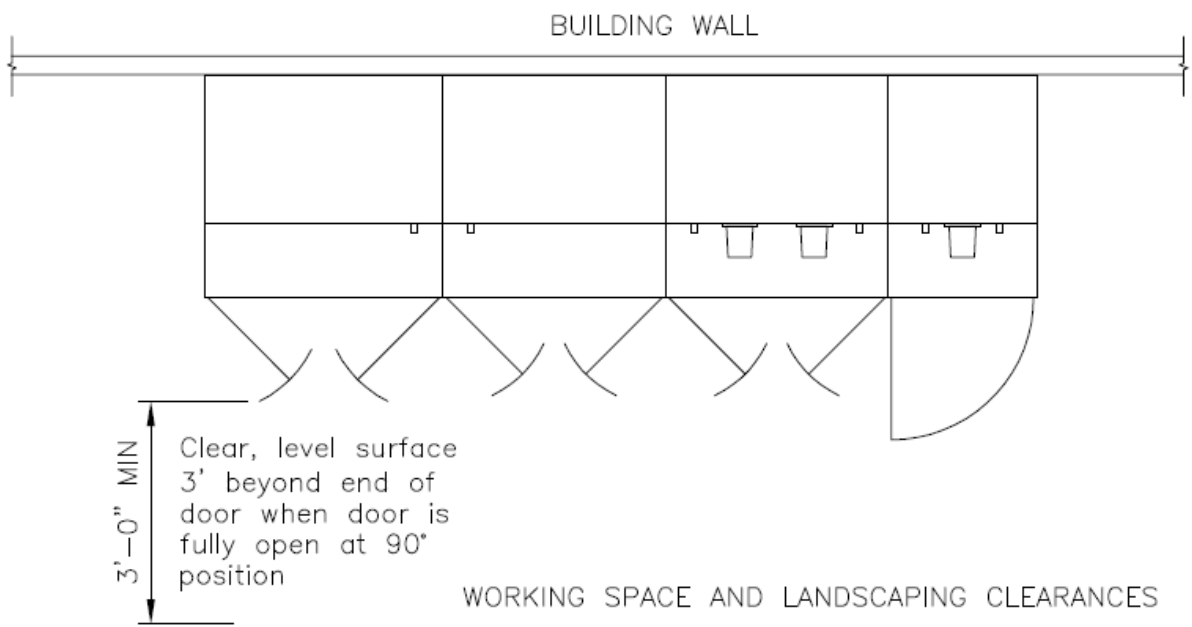

## Guard Posts for Pad Mounted Equipment

Cement filled guard posts shall be installed around pad mounted equipment that is exposed to vehicular traffic. The customer may be required to supply and install these guard posts to protect the pad mounted equipment. These posts may be set to surround the equipment at a maximum of 5' between posts, with a minimum clearance of 2' on the sides and 3' at the front and rear of the equipment. If a center post is placed in front of the doors to the equipment, a minimum clearance of 6' is required.

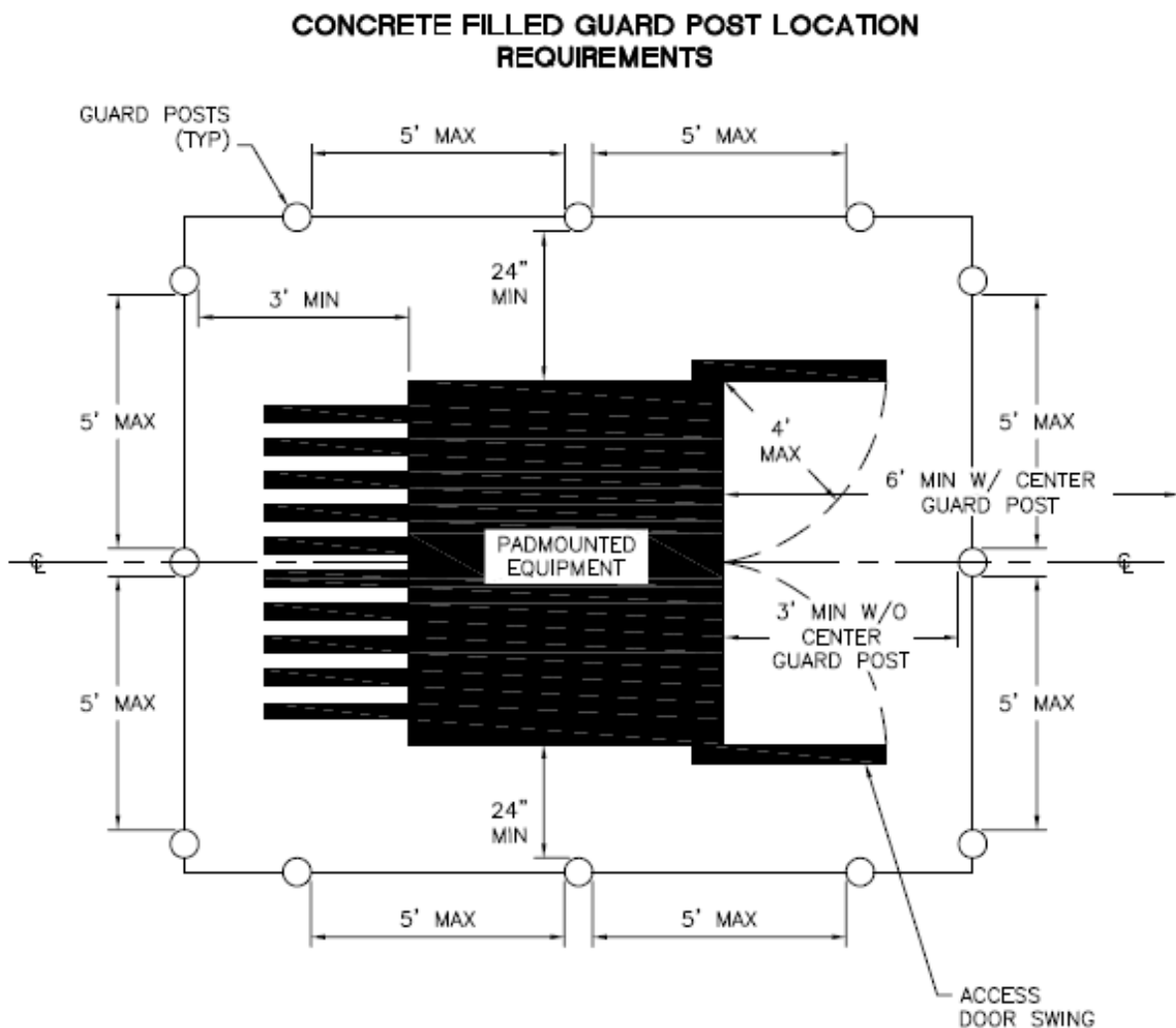

## POST BARRIER

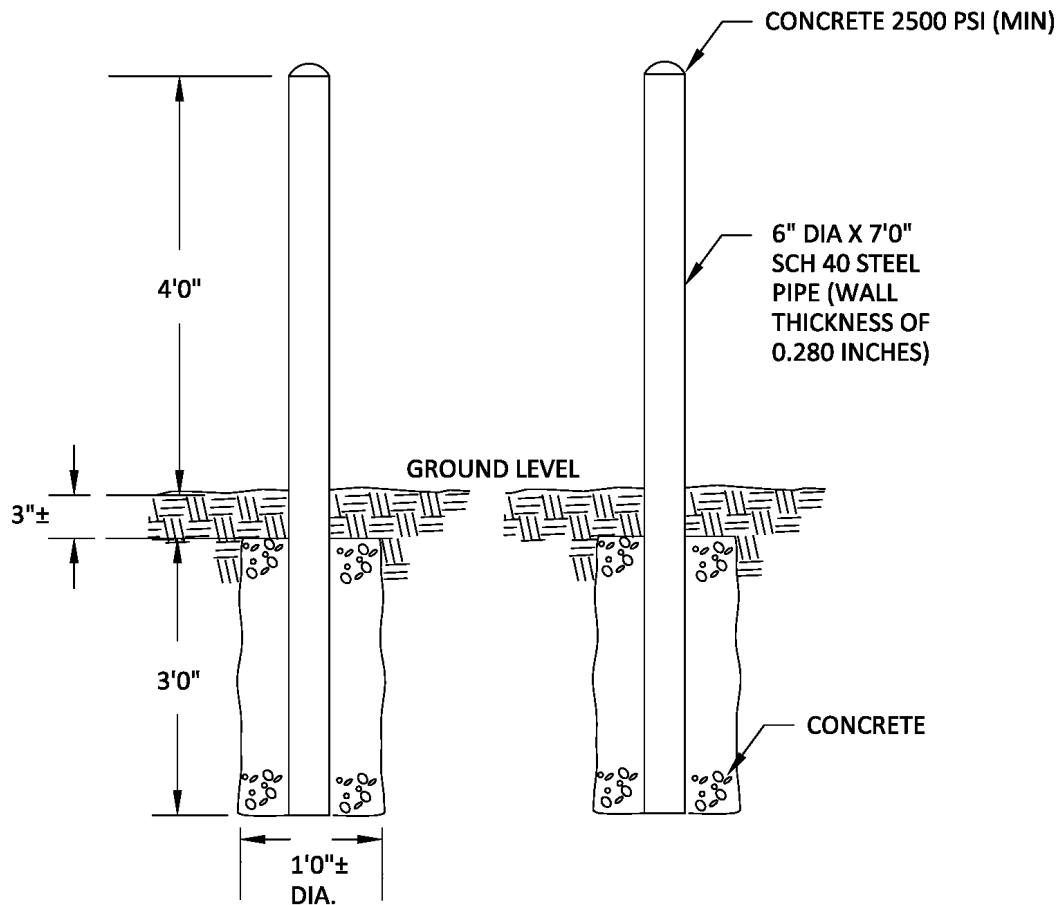

### NOTES:

1. CLEAN AND PRIME ALL EXPOSED METAL. PAINT UNIT WITH GLOSS OR SEMI-GLOSS CANARY YELLOW EXTERIOR ACRYLIC.
2. UNIT SHALL NOT OBSTRUCT OR INTERFERE WITH EQUIPMENT OPERATION OR ACCESS TO EQUIPMENT.
3. FILL PIPE COMPLETELY WITH CONCRETE. TOP OF PIPE SHALL HAVE CONCRETE ROUNDED TO SHED WATER.
4. SURFACE RESTORATION OTHER THAN TAMPING IS NOT PART OF THIS UNIT.

0034

## TEMPORARY POWER SERVICES

---

A temporary service connection may be installed to supply electricity for a limited time (up to 18 months). Services used for construction purposes, fairs, carnivals, holiday lighting, street decorations, or other uses are considered temporary.

- A billing account must be established for each specific location with the Association.
- A temporary electric meter will be installed upon receipt of the inspector's approval of the temporary or permanent meter loop inspection.
- It is the responsibility of the applicant to obtain such an inspection and release.
- The meter will not be installed unless it meets the Association's specifications.
- Contact Engineering Services (303) 688-3100, ext. 5302 with any questions.
- Anyone making unauthorized meter bypasses may be prosecuted.

### Temporary Overhead Power Source

- A temporary service is installed on an Association pole, preferably one equipped with a transformer.
- A temporary service may not be installed on a pole with risers or other special equipment on it.
- If a meter pole is available when temporary service is required, the applicant may avoid installing two services by constructing a permanent service loop on the meter pole and using it for temporary purposes (check for county regulations).

OVERHEAD – TEMPORARY CONSTRUCTION  
SINGLE PHASE (400 AMPS OR LESS)  
THREE PHASE (200 AMPS OR LESS)

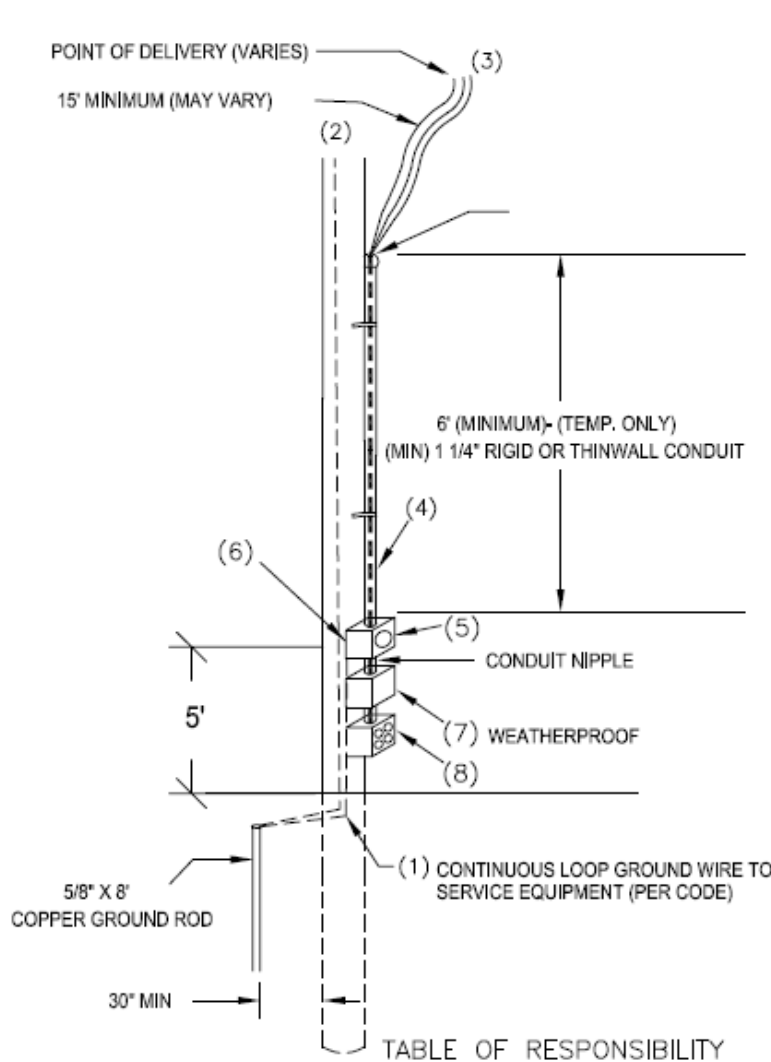

NOTES

1. MAGNETIC CIRCUIT BREAKERS REQUIRED FOR ALL SINGLE-PHASE SERVICES UP TO 200A, FUSED DISCONNECTS NOT ALLOWED.
2. ALL METER LOOP CONDUITS ARE REQUIRED TO BE METALLIC.
3. METER LOOP MUST BE INSTALLED ON AN IREA POLE, PREFERABLY WITH A TRANSFORMER, OR THERE WILL BE A CHARGE TO INSTALL A TRANSFORMER.
4. IF A METER POLE IS INSTALLED PRIOR TO TEMPORARY SERVICE, THE ASSOCIATION RECOMMENDS CUSTOMER INSTALL PERMANENT METER LOOP FOR TEMPORARY POWER.
5. TEMPORARY SERVICE WILL BE ALLOWED A MAXIMUM OF 18 MONTHS.
6. THE ASSOCIATION RESERVES THE RIGHT TO REFUSE TO CONNECT ANY UNSAFE SERVICE INSTALLATION.
7. PLEASE CHECK WITH YOUR LOCAL INSPECTOR FOR NATIONAL, STATE, OR LOCAL CODE REQUIREMENTS. THIS INFORMATION MAY NOT BE SUPPLIED BY ASSOCIATION.
8. ANYONE MAKING UNAUTHORIZED METER BYPASSES MAY BE PROSECUTED.
9. ALL CONNECTIONS TO ASSOCIATION SERVICE MUST BE MADE BY ASSOCIATION PERSONNEL ONLY.

TABLE OF RESPONSIBILITY

KEY NO.	MATERIAL OR WORK DESCRIPTION	MATERIAL	INSTALLATION	OWNERSHIP AND MAINTENANCE
1	CONTINUOUS LOOP GROUND WIRE TO SERVICE EQUIPMENT (PER CODE)	CUSTOMER	CUSTOMER	CUSTOMER
2	POLE & GROUND ROD	ASSOCIATION	ASSOCIATION	ASSOCIATION
3	SERVICE CONNECTION	-----	ASSOCIATION	-----
4	CONDUIT & CONDUCTOR TO SERVICE ENTRANCE	CUSTOMER	CUSTOMER	CUSTOMER
5	METER HOUSING (ASSOCIATION REQUIRED SPECS.) 200 AMP	CUSTOMER	CUSTOMER	CUSTOMER
6	WIRING/ CONNECTIONS	-----	CUSTOMER	-----
7	MAIN & GROUND-FAULT BREAKER REQ'D	CUSTOMER	CUSTOMER	CUSTOMER
8	WEATHER PROOF RECEPTACLES	CUSTOMER	CUSTOMER	CUSTOMER

0071

## Temporary Underground Power Source

- Areas with underground facilities may have metering pedestals, power pedestals, or pad-mounted transformers available.
- A metering pedestal will contain the permanent meter even while the temporary loop is in use. For this reason, a main breaker large enough to protect the permanent service must be installed in the metering pedestal before a temporary service may be connected.
- If a double-breaker kit is required (available with some Milbank pedestals whereas the service amperage exceeds 200 amps, but is less than 400 amp or 320 amp continuous load), the second breaker must be installed prior to the installation of the temporary meter.
- The Association supplies and installs jumpers from meter socket to breakers.

### DOUBLE-BREAKER KIT IN METER PEDESTAL 200-400 AMP SERVICE

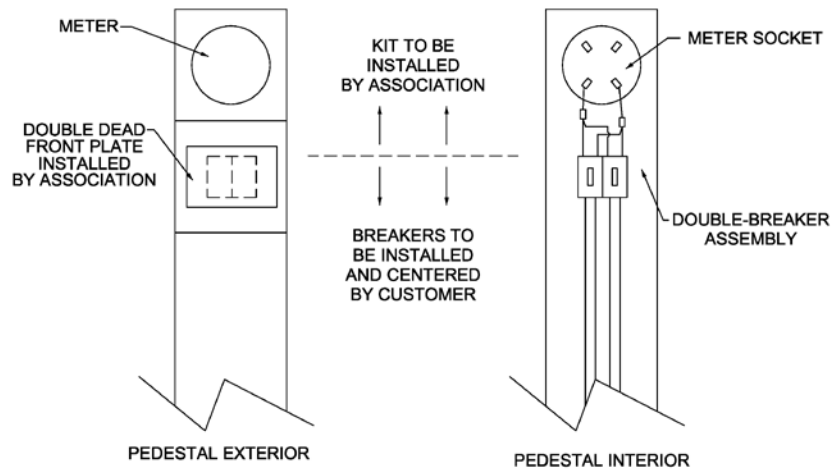

#### NOTE:

1. BOTH BREAKER ASSEMBLIES MUST BE INSTALLED AND CENTERED PRIOR TO TEMP SERVICE.
2. CONTINUOUS LOADS GREATER THAN 200 AMP MAY REQUIRE THE INSTALLATION OF A NEW 400 AMP PEDESTAL.
3. LEVER BYPASS REQUIRED FOR 400 AMP SERVICES.

TEMPORARY UNDERGROUND SERVICE  
AT METER PEDESTAL, SINGLE PHASE  
(400 AMPS OR LESS)

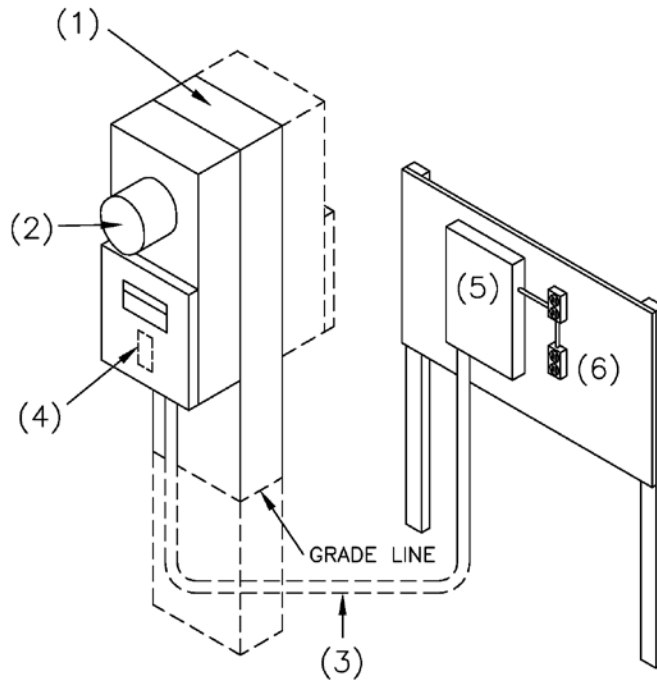

NOTES:

1. THE MAIN BREAKER IS REQUIRED IN THE METER PEDESTAL. IF SECOND BREAKER WILL BE REQUIRED FOR PERMANENT SERVICE, BOTH BREAKERS MUST BE INSTALLED AT TEMPORARY STATUS.
2. TEMPORARY METER WILL BE INSTALLED IN METER PEDESTAL.
3. SERVICE ADDRESS MUST BE PROMINENTLY DISPLAYED ON TEMPORARY SERVICE INSTALLATION.
4. ALL CONNECTIONS TO THE ASSOCIATIONS EQUIPMENT MUST BE MADE BY ASSOCIATION PERSONNEL.
5. TEMPORARY SERVICE WILL BE ALLOWED FOR A MAXIMUM OF 18 MONTHS.
6. THE ASSOCIATION RESERVES THE RIGHT TO REFUSE TO CONNECT ANY UNSAFE INSTALLATIONS.

TABLE OF RESPONSIBILITY

KEY NO.	MATERIAL OR WORK DESCRIPTION	MATERIAL	INSTALLATION	OWNERSHIP AND MAINTENANCE
1	METER PEDESTAL	ASSOCIATION	ASSOCIATION	ASSOCIATION
2	ELECTRIC METER	ASSOCIATION	ASSOCIATION	ASSOCIATION
3	CONDUIT AND SERVICE CONDUCTOR	CUSTOMER	CUSTOMER	CUSTOMER
4	BREAKER(S) IN PEDESTAL	CUSTOMER	CUSTOMER	CUSTOMER
5	BREAKER PANEL	CUSTOMER	CUSTOMER	CUSTOMER
6	CONNECTION, METER HOUSING	CUSTOMER	CUSTOMER	CUSTOMER

- If the source is a power pedestal or power transformer, the temporary stand must be located within 10' of its source. The temporary stand also must be set at the permanent source as designated by the Association's maps.

TEMPORARY UNDERGROUND SERVICE  
AT TRANSFORMER OR SECONDARY TAP ENCLOSURE  
SINGLE PHASE (400 AMPS OR LESS)

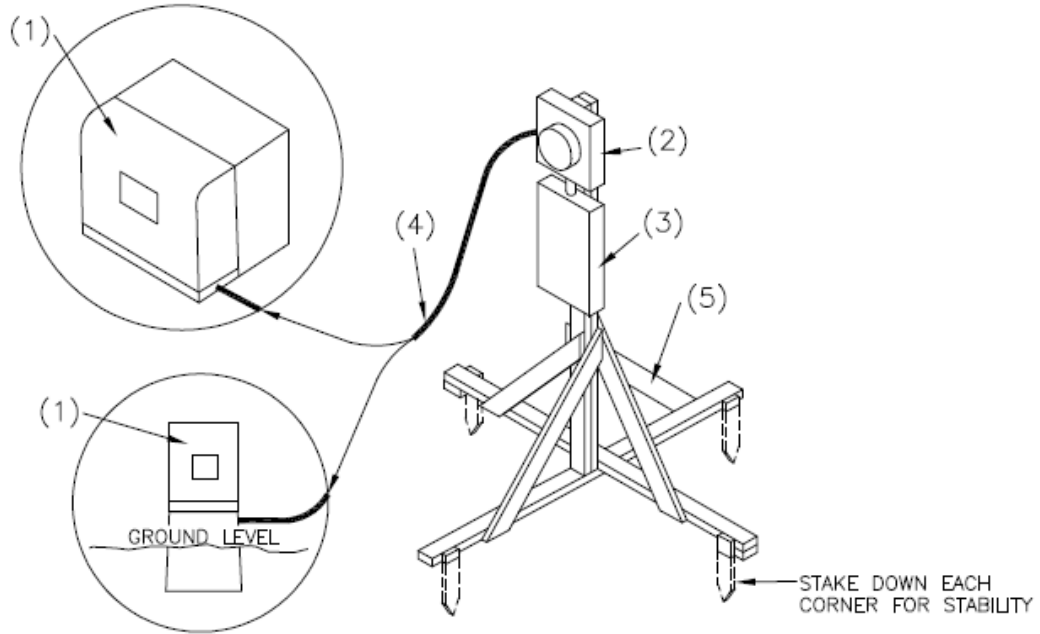

NOTE:

1. ALL CONNECTIONS TO ASSOCIATION DISTRIBUTION EQUIPMENT MUST BE MADE BY ASSOCIATION PERSONNEL ONLY.
2. THE ASSOCIATION RESERVES THE RIGHT TO REFUSE TO CONNECT ANY UNSAFE INSTALLATION.
3. INSTALLATION MUST BE LESS THAN 10 FEET FROM SERVICE PEDESTAL OR RIGHT SIDE OF PADMOUNT TRANSFORMER (FACING FRONT). SERVICE GROUND PROVIDED BY CONNECTION TO DRIVEN GROUND ROD WITHIN COMPANY PEDESTAL OR TRANSFORMER WHERE PERMITTED BY LOCAL NEC CODE. (NO GROUND ROD SHALL BE DRIVEN WITHIN THE UTILITY EASEMENT).
4. WHERE FLEX CONDUIT ATTACHES TO PEDESTAL OR TRANSFORMER, A SUITABLE CONNECTOR FOR 1 1/2" FLEXIBLE CONDUIT TO 1" KNOCK-OUT MUST BE SUPPLIED BY CUSTOMER.
5. MINIMUM WIRE SIZE 3 #6 AL. OR CU.
6. SERVICE ADDRESS MUST BE PROMINENTLY DISPLAYED ON TEMPORARY SERVICE INSTALLATION.
7. TEMPORARY SERVICE LOCATION IS SUBJECT TO ASSOCIATION APPROVAL.
8. TEMPORARY SERVICE WILL BE ALLOWED FOR 18 MONTHS.

TABLE OF RESPONSIBILITY

KEY NO.	MATERIAL OR WORK DESCRIPTION	MATERIAL	INSTALLATION	OWNERSHIP AND MAINTENANCE
1	DISTRIBUTION FACILITY TRANSFORMER OR POWER PEDESTAL	ASSOCIATION	ASSOCIATION	ASSOCIATION
2	METER HOUSING	CUSTOMER	CUSTOMER	CUSTOMER
3	DISCONNECT DEVICE (GROUND FAULT BREAKERS REQ'D)	CUSTOMER	CUSTOMER	CUSTOMER
4	FLEXIBLE CONDUIT AND SERVICE WIRE	CUSTOMER	CUSTOMER	CUSTOMER
5	TEMPORARY STRUCTURE	CUSTOMER	CUSTOMER	CUSTOMER

## Temporary CT Metering

- CT/PT metering is required for single-phase loads greater than 320amp continuous or 400amp peak and three-phase loads greater than 200amp. See Current Transformer – CT and Potential Transformer – PT Metering Section.

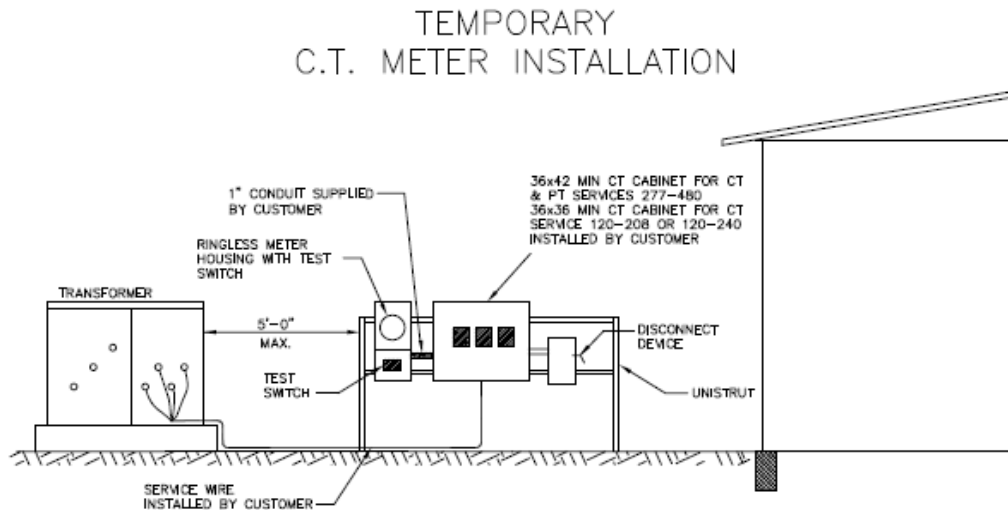

	METER SOCKET	# OF CTS	METER	TEST SWITCH	MISC.
CT 1 PHASE	8 TERM.	2 CTS	SINGLE PHASE OR SINGLE PHASE DEMAND	YES	MISC. HARDWARE
CT 208 3 PHASE	13 TERM.	3 CTS	THREE PHASE OR THREE PHASE DEMAND	YES	MISC. HARDWARE
CT 480 3 PHASE	13 TERM.	3 CTS/3 PTS	THREE PHASE OR THREE PHASE DEMAND	YES	MISC. HARDWARE

### NOTES:

- LOCATION OF SERVICE MUST BE ACCESSIBLE TO ASSOCIATION AT ALL TIMES.
- CT METER TO BE INSTALLED BY ASSOCIATION PERSONNEL ONLY.
- CTS MAY BE MOUNTED IN CUSTOMER SUPPLIED CT CAN OR SWITCHGEAR.
- ANY VARIANCE CONTACT METER DEPARTMENT AT ASSOCIATION
- TEMP. SERVICE SHOULD BE LESS THAN 18 MONTHS
- CT METERING IS REQUIRED FOR SINGLE PHASE SERVICE GREATER THAN 400 AMP (OR 320 AMP CONTINUOUS LOADS), AND THREE PHASE SERVICE GREATER THAN 200 AMP.

## RESIDENTIAL POWER SERVICES (Single Lot, Multi-Family and Development)

### Street Lighting

- The Association offers street light facilities upon request to serve cities, towns, villages, residential, and commercial consumers of the Association for the installation of street lights at or near the entrance to consumer-owned property, subdivision lighting, and highway lighting. Two styles of LED ornamental street light facilities are used in subdivisions with underground

facilities; whereas in areas with overhead facilities; LED lights are placed on wooden poles.

- The cost of installation for a street light and electrical feed is typically incorporated into the distribution design of developments. The cost for street light facilities will vary depending upon the size of the lots, the desired location of the street lights, and the electric sources available to serve the new street lights.
- It will be the responsibility of the property owner or developer to contact the proper city or county authorities for street light specifications, as design requirements may vary.
- Should the applicant wish to install ornamental lights that are not within the Association's specifications, they may do so at their own expense. The Association will provide metering points at the applicant's cost and will bill for the actual energy consumption. The applicant will be responsible for the acquisition, installation, and maintenance of all such facilities beyond the metering point.

### Joint-Trench

- Subdivisions with underground electrical service frequently have telephone and cable television facilities in the same trench with electrical distribution. The applicant may contact the Association Engineering Department for information required to coordinate joint trenching of facilities.
- If construction is assigned to the Association's contractor, any contracts or agreements regarding joint-trench will be made with that contractor, not the Association. Joint-trench facilities are normally used for distribution lines but can include secondary (house) laterals as well.
- Gas and water lines cannot be included in the electrical trench. All utilities requesting joint-trench use must be designed and ready to install at the time the Association's facilities are scheduled for construction.

### Meter Sets

- The applicant must establish an account for new service. A *New Location Request Form* will be mailed, faxed or emailed to the applicant. This form needs to be completed and returned to Engineering Services via fax at (720)733-5764 or email [engineering@irea.coop](mailto:engineering@irea.coop).

- If the meter is to be used strictly for temporary construction purposes only and then to be removed from the site, the applicant should indicate “temp only” on this form.
- The Association will issue a service order to set the meter upon receipt of the inspector’s approval of the temporary or permanent meter loop inspection.
- Please allow three to ten business days for the meter set to be completed.
- A deposit in the amount of an estimated 60-day bill may be required. Such deposit may be in addition to any advance, contribution, or guarantee provided for in the extension regulations.

### Choosing the Right Service Voltage

The Association offers their customers the voltages shown in the table below.

Service Type	Voltage
Single-phase	120/240V, 3-wire*
Three-phase	120/208V, 4-wire 277/480V, 4-wire
Primary Single-Phase	7200V, 3-wire
Primary Three-Phase	7200/12470V, 4-wire

\*Available for loads to a maximum demand of 100kW. Larger loads may be served, if determined feasible by an Association engineer. All motors must be rated 10 HP or less.

### Meter Locations

- An electric meter will not be located in any area considered hazardous or inside where reading, testing, or servicing of the meter may become impracticable.
- A distance of 4’ clearance must be maintained in front of the meter.
- The meter shall be located 5’ at center of glass, above clear and level ground.
- The meter will be located on the front 25% of the house, *ahead of any fences*, and in a direct line with the Association’s electrical facility designated to serve that location.

- Where meters, originally installed in accessible locations satisfactory to the Association, are rendered inaccessible by virtue of alterations or new construction by the owner of the premises or his agents, such meters shall be reinstalled at a point designated by the Association at the expense of the property owner.
- The location of meters and metering equipment shall be designated by the Association Engineering Department personnel. No wiring dependent upon the meter location should be started until such location has been definitely established.
- Service disconnect shall be located within 30" and accessible from meter housing.
- Meter housings are not provided by the Association. See Specifications for Meter Housings, Locations, and Installations.
- Only one meter will be issued per structure. Contact the Association Metering Department for detailed information.

### METER AND CONDUIT LOCATION DETAIL

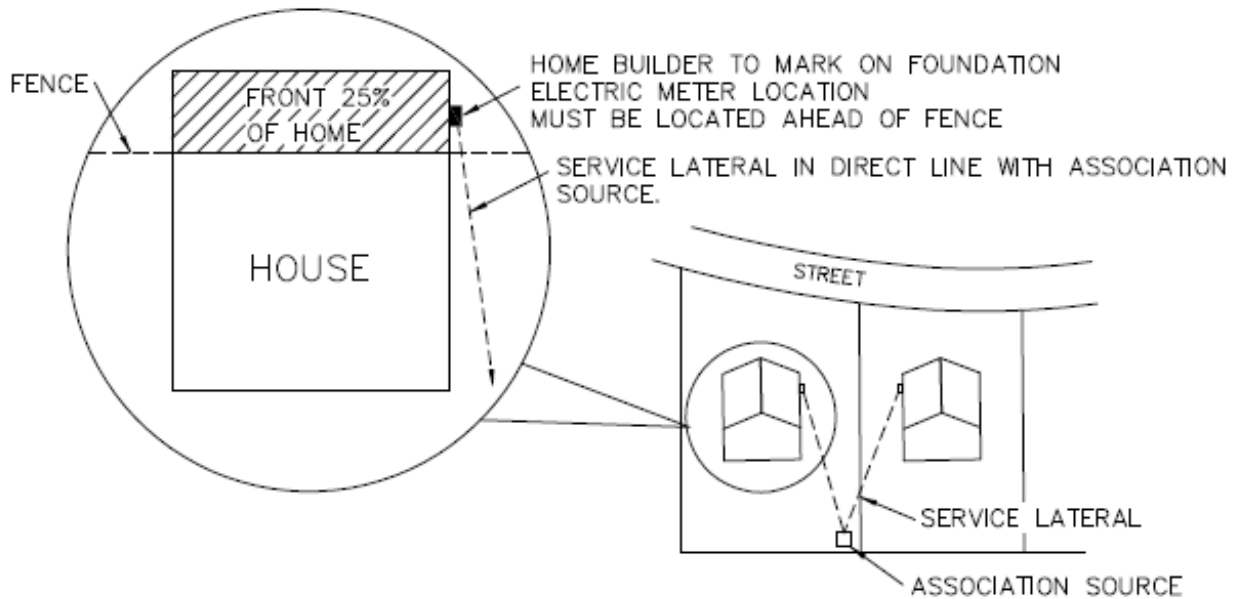

- If the service is underground to a power pedestal, the Association will install a secondary lateral to the house and the meter will be located on the house.

METER ON BUILDING  
UNDERGROUND RESIDENTIAL SINGLE-PHASE  
SERVICE (400 AMPS OR LESS)

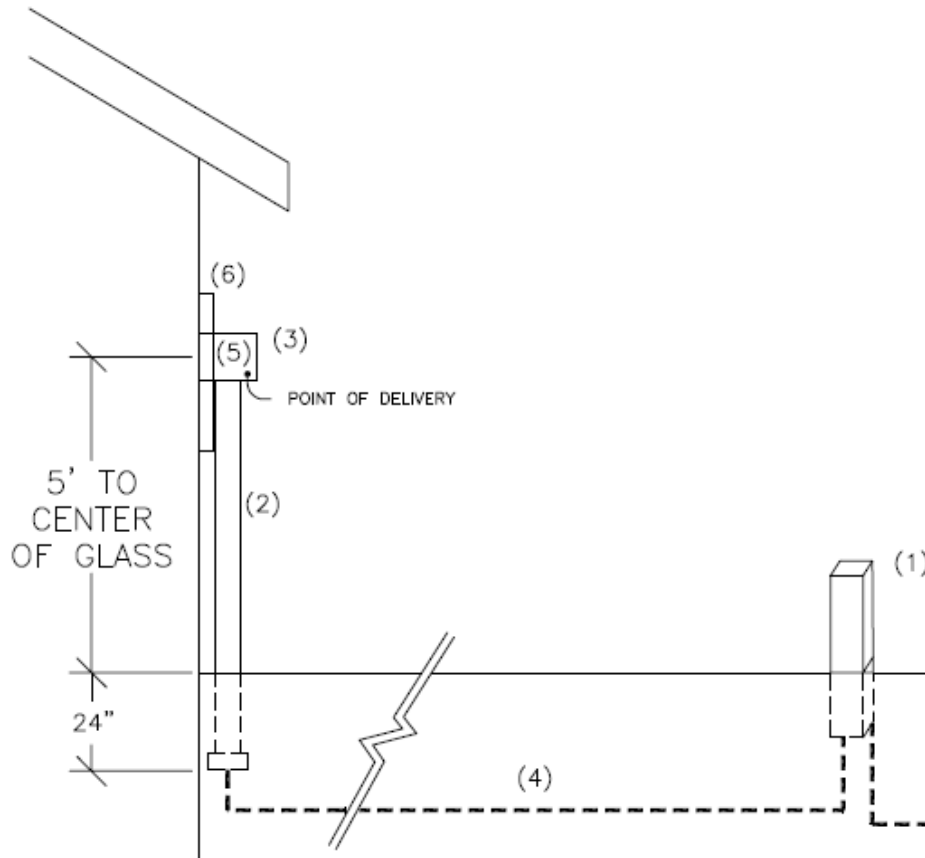

NOTES:

1. SERVICE DISCONNECT SHALL BE LOCATED WITHIN 30" AND ACCESSIBLE FROM METER HOUSING.
2. LEVER BYPASS REQUIRED FOR 400 AMP SERVICES.

TABLE OF RESPONSIBILITY

KEY NO.	MATERIAL OR WORK DESCRIPTION	MATERIAL	INSTALLATION	OWNERSHIP AND MAINTENANCE
1	DISTRIBUTION FACILITIES (TRANS. OR PED.)	ASSOCIATION	ASSOCIATION	ASSOCIATION
2	CONDUIT SERVICE ENTRANCE	CUSTOMER	CUSTOMER	CUSTOMER
3	METER HOUSING	CUSTOMER	CUSTOMER	CUSTOMER
4	CONDUCTOR, SERVICE LATERAL	ASSOCIATION	ASSOCIATION	ASSOCIATION
5	CONNECTION, METER HOUSING	---	ASSOC./CUST.	---
6	DISCONNECT	CUSTOMER	CUSTOMER	CUSTOMER

000-R

- If the service is underground to a meter pedestal, the meter is located within the meter pedestal, and the applicant will be required to install the secondary lateral to the house. Loads greater than 320 amp continuous will require CT metering and adhere to the EUSERC standards.

METER PEDESTAL  
UNDERGROUND RESIDENTIAL SINGLE-PHASE  
SERVICE (400 AMPS OR LESS)

BREAKER TYPE (3R ENCLOSURE)

TYPE METER PEDESTAL	BREAKER TYPE	COMMENTS
MILBANK	BRYANT TYPE: BR/BJ LINE GE: TQDL 21, GE: TQD 22 ITE: QP OR QT LINE WESTINGHOUSE: CAZ LINE	200 AMP SERVICE 400 AMP SERVICE REQUIRES DOUBLE-BREAKER KIT TO BE INSTALLED BY ASSOCIATION PERSONNEL
SMALL DURHAM	WESTINGHOUSE TYPE: QUICKLAG P, BRYANT TYPE: BR, SQUARE D., HOME LINE ITE: QP	60 TO 125 AMP
STANDARD DURHAM	SAME AS MILBANK	200 AMP
LARGE DURHAM	SAME AS MILBANK	200 TO 400 AMP (400 AMP SERVICES REQUIRE TWO, 200 AMP BREAKERS)

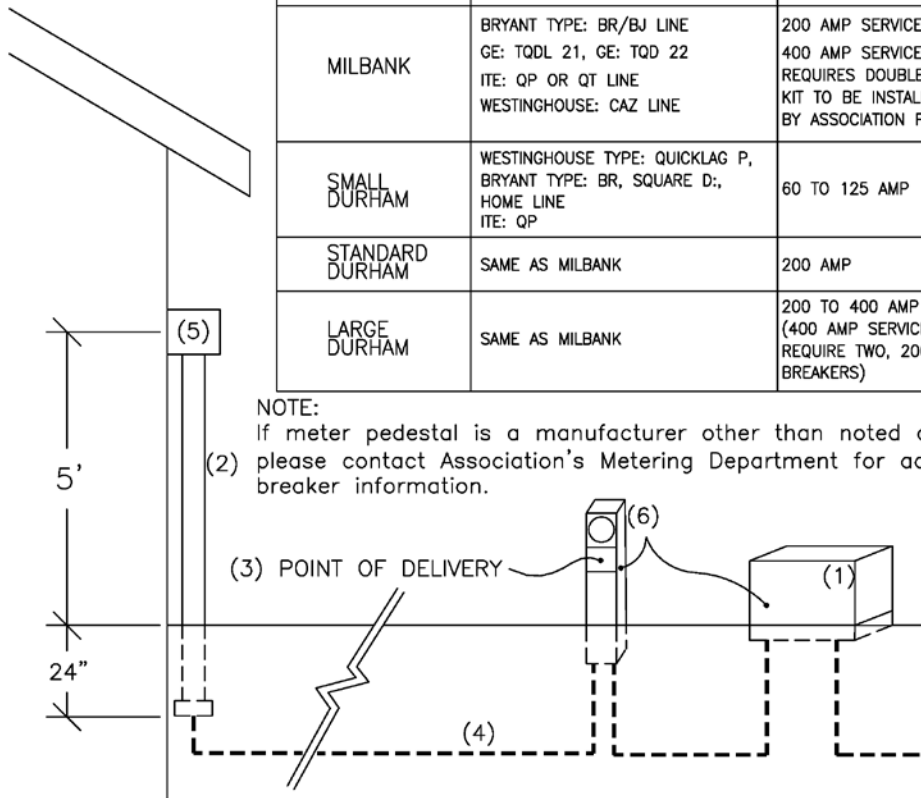

NOTE:

(2) If meter pedestal is a manufacturer other than noted above, please contact Association's Metering Department for additional breaker information.

NOTES:

1. DOUBLE-BREAKER KIT FOR 400 AMP SERVICE ON MILBANK PEDESTALS ARE SUPPLIED AND INSTALLED BY ASSOCIATION.
2. IF DOUBLE-BREAKER KIT IS REQUIRED, BOTH BREAKER ASSEMBLIES MUST BE INSTALLED AND CENTERED PRIOR TO TEMPORARY SERVICE.
3. FINAL CONNECTIONS FROM BREAKER TO METER MUST BE MADE BY ASSOCIATION'S PERSONNEL.
4. CONTINUOUS LOADS GREATER THAN 320 AMP MAY REQUIRE THE INSTALLATION OF A NEW 400 AMP METER PEDESTAL.
5. LEVER BYPASS REQUIRED FOR 400 AMP SERVICES.

TABLE OF RESPONSIBILITY

KEY NO.	MATERIAL OR WORK DESCRIPTION	MATERIAL	INSTALLATION	OWNERSHIP AND MAINTENANCE
1	DISTRIBUTION FACILITIES	ASSOCIATION	ASSOCIATION	ASSOCIATION
2	CONDUIT SERVICE ENTRANCE	CUSTOMER	CUSTOMER	CUSTOMER
3	BREAKER(S) IN PEDESTAL	CUSTOMER	CUSTOMER	CUSTOMER
4	CONDUCTOR, SERVICE LATERAL	CUSTOMER	CUSTOMER	CUSTOMER
5	PANEL CONNECTION	---	CUSTOMER	---
6	METER PEDESTAL	ASSOCIATION	ASSOCIATION	---

0072-R

- If the service is overhead to the house, the meter will be located on the house.

### SINGLE-PHASE OVERHEAD RESIDENTIAL (200 TO 400 AMPS)

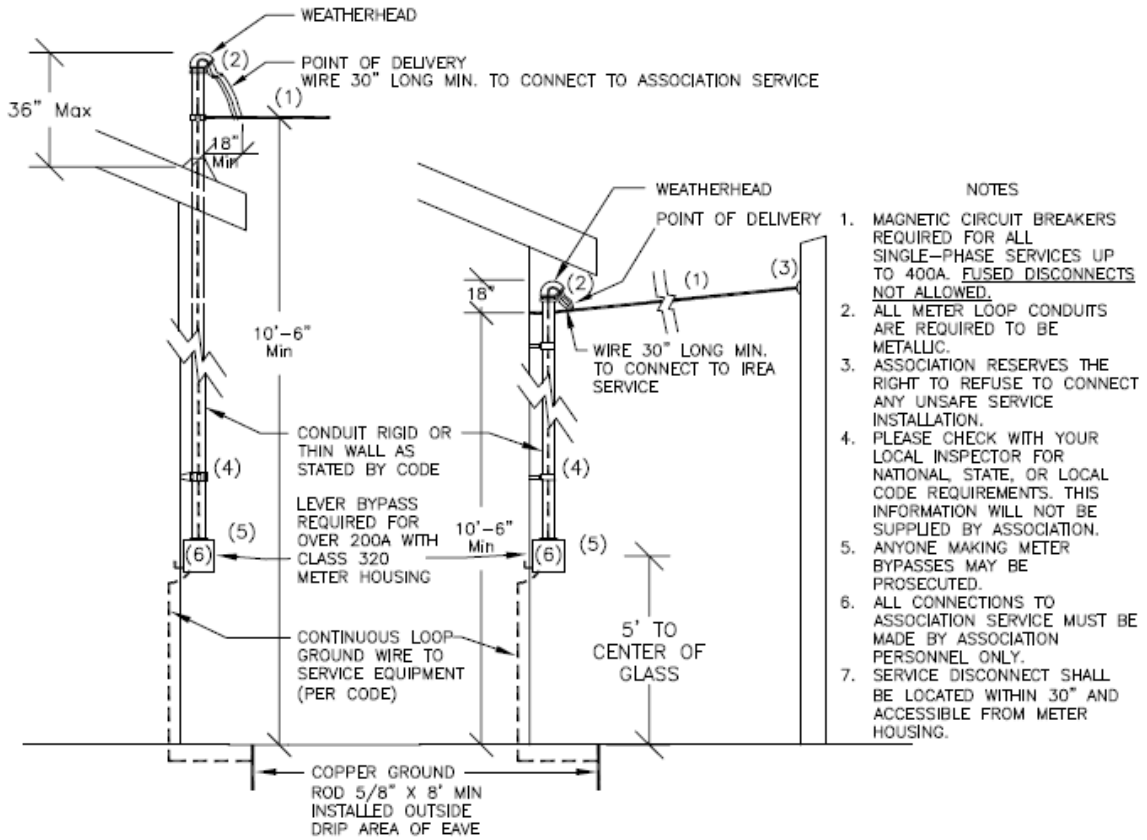

TABLE OF RESPONSIBILITY

KEY NO.	MATERIAL OR WORK DESCRIPTION	MATERIAL	INSTALLATION	OWNERSHIP AND MAINTENANCE
1	SERVICE DROP	ASSOCIATION	ASSOCIATION	ASSOCIATION
2	SERVICE CONNECTION	-----	ASSOCIATION	-----
3	SERVICE DROP CONNECTION	-----	ASSOCIATION	-----
4	CONDUIT AND CONDUCTOR TO SERVICE ENTRANCE	CUSTOMER	CUSTOMER	CUSTOMER
5	METER HOUSING WITH LEVER BYPASS	CUSTOMER	CUSTOMER	CUSTOMER
6	CONNECTION, METER HOUSING	-----	CUSTOMER	-----
7	DISCONNECT	CUSTOMER	CUSTOMER	CUSTOMER

002-8

- If the service is overhead to the meter pole and then underground to the house, the meter will remain on the meter pole, and the applicant will be required to install the secondary to the house.

## SINGLE-PHASE OVERHEAD – METER POLE RESIDENTIAL (200 TO 400 AMPS)

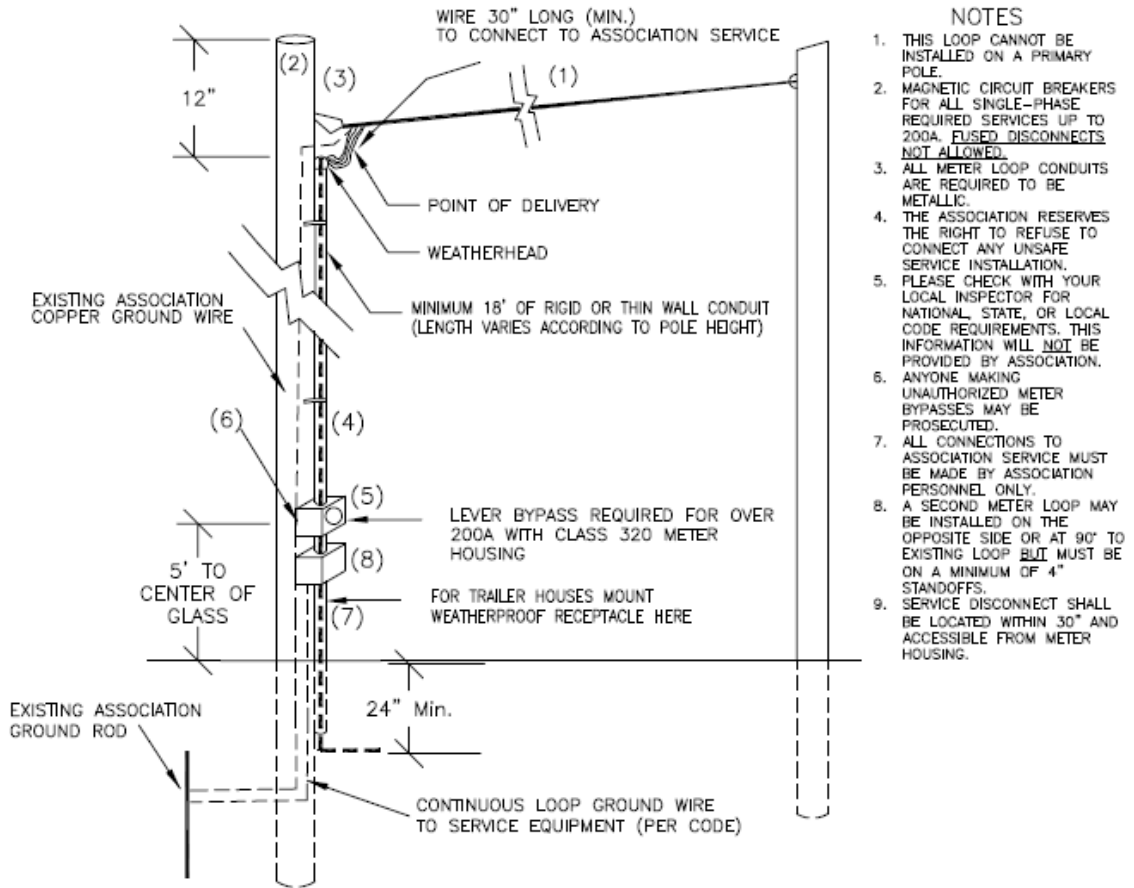

### NOTES

1. THIS LOOP CANNOT BE INSTALLED ON A PRIMARY POLE.
2. MAGNETIC CIRCUIT BREAKERS FOR ALL SINGLE-PHASE REQUIRED SERVICES UP TO 200A. FUSED DISCONNECTS NOT ALLOWED.
3. ALL METER LOOP CONDUITS ARE REQUIRED TO BE METALLIC.
4. THE ASSOCIATION RESERVES THE RIGHT TO REFUSE TO CONNECT ANY UNSAFE SERVICE INSTALLATION.
5. PLEASE CHECK WITH YOUR LOCAL INSPECTOR FOR NATIONAL, STATE, OR LOCAL CODE REQUIREMENTS. THIS INFORMATION WILL NOT BE PROVIDED BY ASSOCIATION.
6. ANYONE MAKING UNAUTHORIZED METER BYPASSES MAY BE PROSECUTED.
7. ALL CONNECTIONS TO ASSOCIATION SERVICE MUST BE MADE BY ASSOCIATION PERSONNEL ONLY.
8. A SECOND METER LOOP MAY BE INSTALLED ON THE OPPOSITE SIDE OR AT 90° TO EXISTING LOOP BUT MUST BE ON A MINIMUM OF 4" STANDOFFS.
9. SERVICE DISCONNECT SHALL BE LOCATED WITHIN 30" AND ACCESSIBLE FROM METER HOUSING.

TABLE OF RESPONSIBILITY

KEY NO.	MATERIAL OR WORK DESCRIPTION	MATERIAL	INSTALLATION	OWNERSHIP AND MAINTENANCE
1	SECONDARY	ASSOCIATION	ASSOCIATION	ASSOCIATION
2	POLE & GROUND ROD	ASSOCIATION	ASSOCIATION	ASSOCIATION
3	SERVICE CONNECTION	-----	ASSOCIATION	-----
4	CONDUIT AND CONDUCTOR TO SERVICE ENTRANCE	CUSTOMER	CUSTOMER	CUSTOMER
5	METER HOUSING WITH LEVER BYPASS	CUSTOMER	CUSTOMER	CUSTOMER
6	CONNECTION, METER HOUSING	-----	CUSTOMER	-----
7	CONDUIT AND CONDUCTOR	CUSTOMER	CUSTOMER	CUSTOMER
8	WEATHERPROOF MAIN DISCONNECT DEVICE	CUSTOMER	CUSTOMER	CUSTOMER

000q-R

- CT/PT metering is required for single-phase loads greater than 320amp continuous or 400amp peak and three-phase loads greater than 200amp. See Current Transformer – CT and Potential Transformer – PT Metering Section.

**EUSERC SINGLE METER  
(ELECTRIC UTILITY SERVICE EQUIPMENT  
REQUIREMENT COMMITTEE)**

**NOTES:**

1. ENCLOSED BY LOCKABLE DOORS.
2.  HINGED DOORS  
CT'S & PT'S ARE LOCATED BEHIND METER AND TEST SWITCH.
3. LOCATED OUTDOORS ONLY
4. ENCLOSURE: NEMA TYPE 3R

3Ø 13 TERMINALS  
1Ø 8 TERMINALS

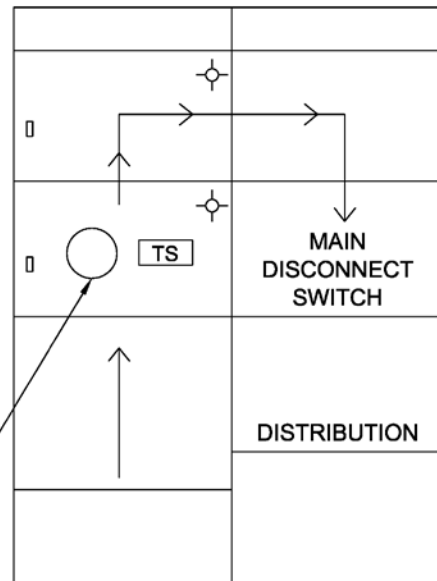

1Ø 240 VOLT OVER 400 AMP  
3Ø 208 VOLT OVER 200 AMP  
3Ø 480 VOLT OVER 200 AMP

\*  HOT SEQUENCE  
TO ASSOCIATION  
TRANSFORMER

### Service Laterals (installed by Association)

The Association will install the service lateral at such time that the foundation is in and backfilled to final grade ( $\pm 6''$ ), and the location of the meter service has been marked on the foundation. To facilitate the timely installation of the service lateral and eliminate additional costs, please refer to the following procedure.

1. A *New Location Request Form* for the new permanent service must be requested to initiate an account prior to ordering the lateral, if an account has not yet been established.
2. Notify the Association to schedule the lateral service installation by submitting a *Builder/Developer Service Lateral Form* to Engineering Services for processing.
3. Mark "E" (with paint) on the foundation wall. Remember the following guidelines when marking the location of the meter socket.
  - a. Meters will not be located in any area considered hazardous or inside where reading, testing, or servicing of the meter may become impracticable.
  - b. Meters will be located on the front 25% of the house, *ahead of any fence*, and in a direct line with the Association's electrical facility designated to serve the house. The meter will be located 5' to center of glass above final grade.

### METER WIRING DETAIL

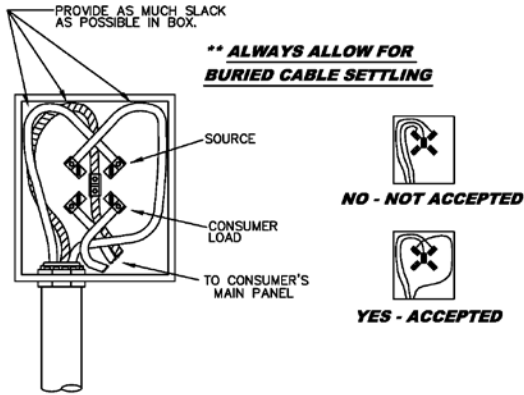

### ALL IN ONE METER HOUSING DETAIL

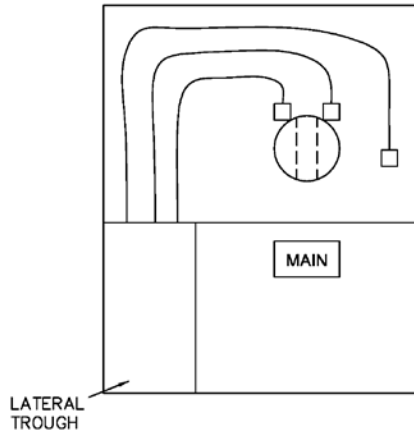

### METER HOUSING DETAIL

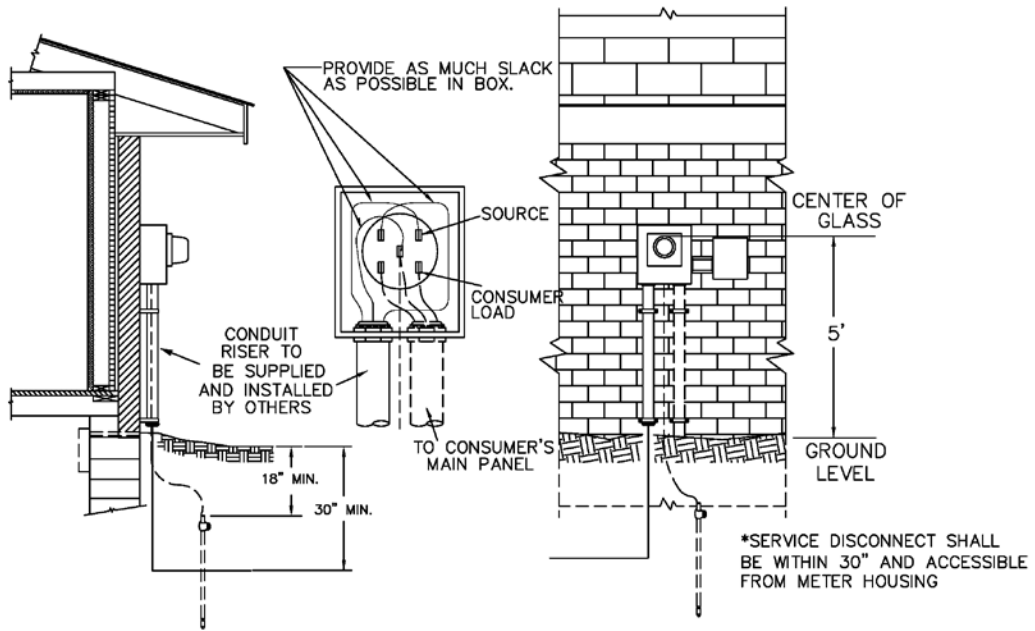

005t

4. Post the address of the property at the curb or in a visible location for locators and construction crews.
5. The Association will install a lateral from the electric power source to the foundation. The wire will be coiled next to the foundation wall. The electrical service will not be energized. Once the house has been framed and sided, an electrician can then mount the meter socket, install the riser, and terminate the wire (line side and load side) in the meter socket. Note that the wire will be color coded. It is imperative that the electrician leave the color code markings on the wire.
6. Remove all trash and building material from the area where the service lateral will be located.

Upon notification, the Association will continuously inspect each location to verify readiness (site condition and foundation being marked for electric service entrance, etc.). The installation of the lateral will be scheduled within a period not to exceed two weeks upon verification of site readiness. If the Association's lateral crew arrives at a site that is not ready, rescheduling the lateral could mean an additional two weeks from that date.

The builder/customer will be responsible for any costs incurred from:

- Cable cuts and any damages caused by the builder or their subcontractor.
- Reinstallation of lateral due to grade changes, meter housing changes, etc.
- Additional materials, i.e., conduit under retaining walls, extended laterals due to location of house, etc.
- Relocation of lateral from original design (other side of house from its source).

## Multiple Meter Installations

### Multi-family

On residential multi-meter panels, the centerline of the bottom row of meters shall be a minimum of 3' and the top row of meters shall be a maximum of 6'-6" above finished grade or floor. The minimum spacing between socket centers shall be 7-1/2" horizontally and 8-1/2" vertically.

Meter base/socket jumpers shall not be used to serve house meters. House meters shall be served in the following manor:

- A dedicated set of service entrance conductors.
- A tap at the bussing of residential multi-meter panels.
- All-in-one factory assembled multi-meter panels.

MULTIPLE METER SINGLE-PHASE  
RESIDENTIAL  
(200 AMPS OR LESS PER METER)

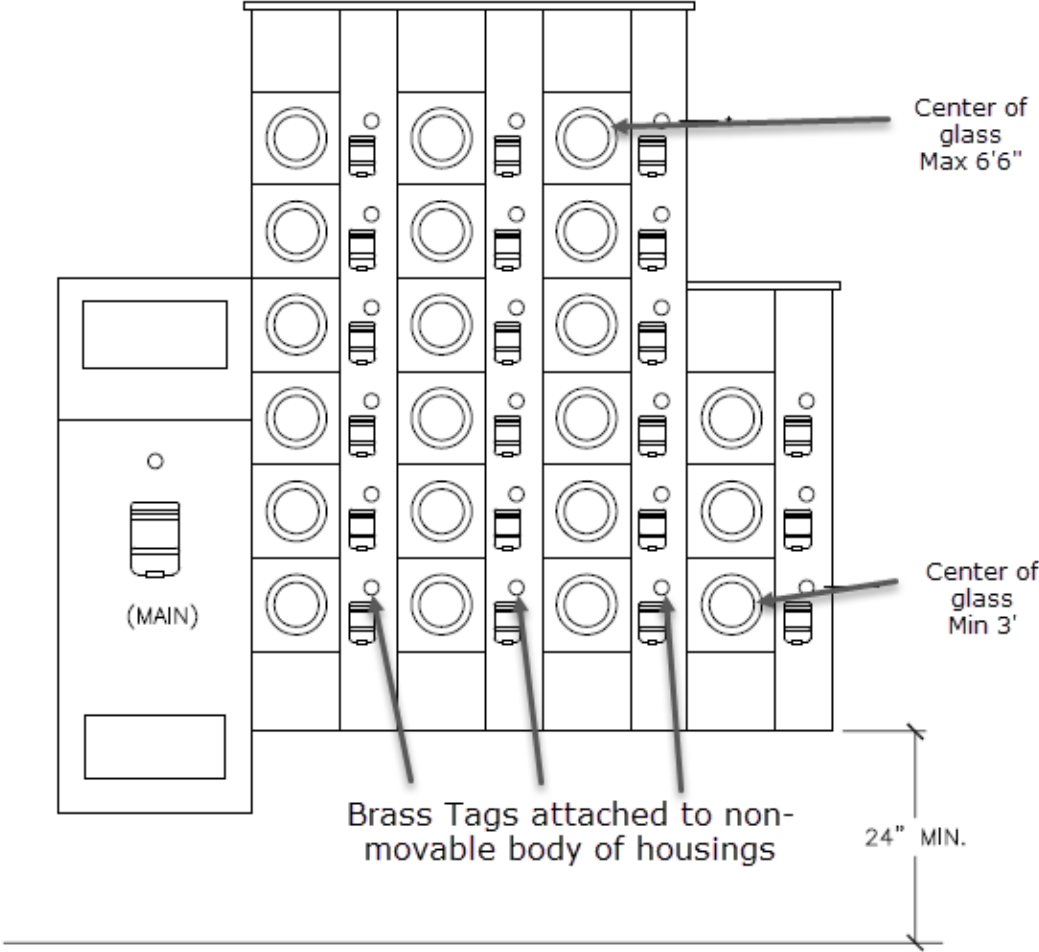

## RESIDENTIAL MULTI-METERING FOR EUSERC APPLICATIONS

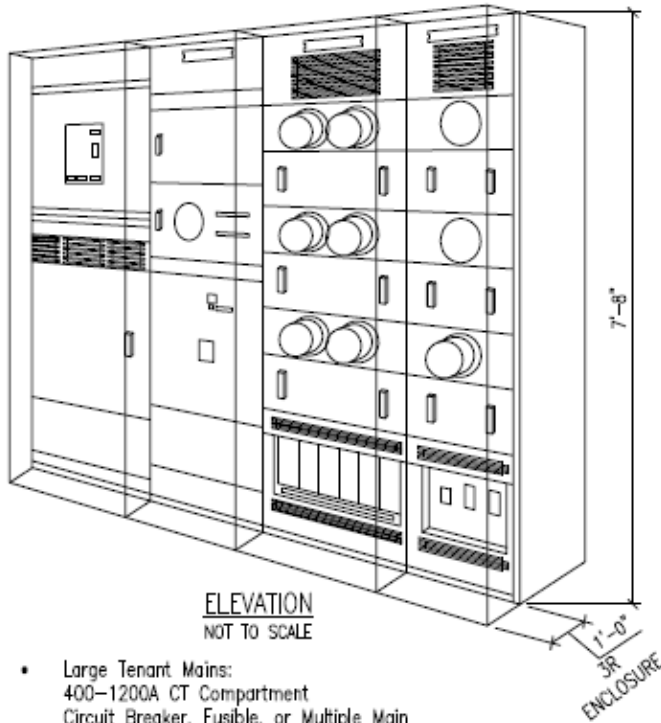
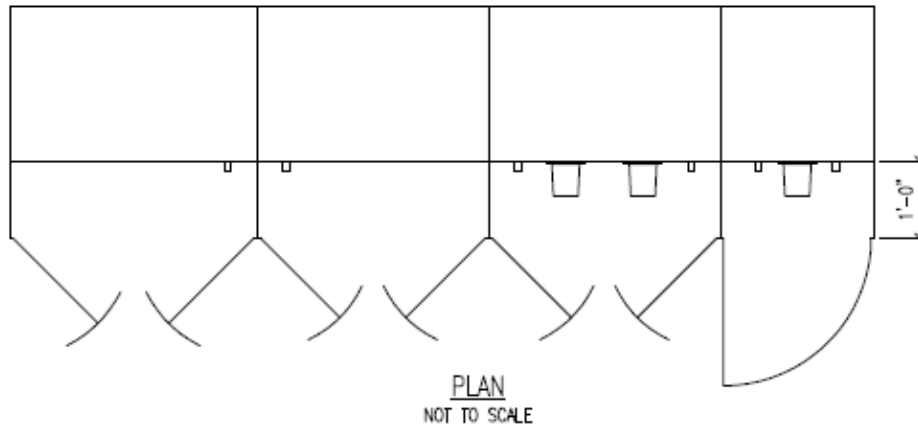

- UL Listed Service Entrance

- Service:  
120/240V 1 $\phi$ 3W ac  
240/120V 3 $\phi$ 4W ac  $\Delta$   
208Y/120 3 $\phi$ 4W ac  
480Y/277V 3 $\phi$ 4W ac

- Ampacity 400–4000A

- SCCR 100,000A rms Symmetrical

- Bussing:  
Aluminum (Standard)  
Copper (Optional)

- Enclosure:  
NEMA Type 3R

- Hot Sequence Metering: EXCEPTION  
6 HANDLE RULE

- Mains:  
Underground Pull Section 400–4000A  
Circuit Breaker 400–4000A  
Fusible Switch 400–4000A

- Large Tenant Mains:  
400–1200A CT Compartment  
Circuit Breaker, Fusible, or Multiple Main

- Meter Sections:  
3–Socket or 6–Socket  
Circuit Breaker or Fusible

- Meter Sockets:  
200A Continuous (5–Jaw or 7–Jaw)  
Plug–On Construction

4 panels–R

## Specifications for Single-Phase 120/240V 3-Wire Meter Housings

- Housings shall be constructed from metal in accordance with the latest revision of Underwriters' Laboratories (UL) Standard No. 414 for meter sockets.
- Each socket on line-side compartment shall be equipped so proper sealing of the socket can be maintained by padlock.
- After installation and sealing are completed, the socket shall not have any openings except as permitted by NEMA Type 3R construction.
- All meter housings shall be UL listed and labeled, and they shall be installed and used in accordance with their labeling.
- Meter housing installations shall be installed per National Electric Code (NEC) procedures and shall be enforced by the local inspection authority.
- Meter housing shall be located five feet (5') to center glass above finished grade.
- Maximum amp size to be metered by a self-contained 1Ø meter will not exceed 320amp continuous or 400amp peak loads. All single-phase services in excess of 200 amps require a class 320 meter and lever bypass meter housing unless preapproved by the Association. Class 320 meters have a maximum continuous load rating of 320 amps. Continuous loads greater than 320 amps will require CT metering which will adhere to the EUSERC standards.
- All existing services that are changed or upgraded because of increased loads, transformer size, wire size, or reconstruction will adhere to the Association's current Standards.

Additional approval will be given to meter/load center combinations as well as multiple combinations, which meet all other provisions for residential/1Ø meter housings.

It is understood that Association approval does not mean approval in any area where there may be a conflict with any national or local code, and the local inspecting body will need to approve and will have the final authority.

It is also understood that in case of a disaster, the Association will not have spare parts and will not be responsible for the repair.

Questions can be answered by the Association Meter Department.

### Additional Requirements for 1Ø Underground Feed Residential Meter Housings

- Minimum size permitted must be 200 amp capable of terminating 4/0 aluminum wire.
- Meter will be located on the front 25% of the house, ahead of fence, and in a direct line with the Association’s electric facility designated to serve that location.

### Additional Requirements for 120/208V 1Ø Hookups

- Fifth (5<sup>th</sup>) terminal is required and will be allowed in the 9 o’clock position only and must be bonded within the housing. Typically used for 1Ø service fed by 3Ø transformer, 120/208 voltage.

### Fault Current Levels and Standard KVA Size Transformers

The most commonly used transformers installed by the Association are shown in the tables below. Tables also show the maximum available short-circuit current at the transformer’s secondary connection point.

**Maximum short circuit current in amps for single-phase pole mounted transformers**

		240 V Windings		120 V Winding	
Secondary Voltage	KVA	Min. % Z	Fault Current	Min. % Z	Fault Current
120/240	10	1.5	2778	1.5	5556
120/240	15	1.5	4167	1.5	8333
120/240	25	1.5	6944	1.5	13889
120/240	37.5	1.5	10417	1.5	20833
120/240	50	1.5	13889	1.5	27778

**Maximum short circuit current in amps  
for single-phase pad mounted transformers**

		240 V Winding		120 V Winding	
Secondary Voltage	KVA	Min. % Z	Fault Current	Min. % Z	Fault Current
120/240	15	1.5	4167	1.5	8333
120/240	25	1.5	6944	1.5	13889
120/240	37.5	1.5	10417	1.5	20833
120/240	50	1.5	13889	1.5	27778
120/240	75	1.5	20833	1.5	41667
120/240	100	1.5	27778	1.5	55556
120/240	167.5	1.5	46528	1.5	93056

## COMMERCIAL/INDUSTRIAL POWER SERVICES

---

### Street Lighting

- The Association offers to provide street lighting on public streets. It shall be the responsibility of the developer to provide lighting in private parking lots.

### Joint-Trench

- Subdivisions with underground electrical service frequently have telephone and cable television facilities in the same trench with electrical distribution. The builder/developer may contact the Association Engineering Department for information required to coordinate joint trenching of facilities.

If construction is assigned to the Association's contractor, any contracts or agreements regarding joint-trench will be made with that contractor, not the Association.

- Gas and water lines cannot be included in the electrical trench. All utilities requesting joint-trench use must be designed and ready to install at the time the Association's facilities are scheduled for construction.

### Meter Sets

- The applicant must establish an account for new service. *A New Location Request Form* will be mailed, faxed or emailed to the builder/customer. This form needs to be completed and returned to Engineering Services via fax (720)733-5764 or email [engineeringervices@irea.coop](mailto:engineeringervices@irea.coop).
- If the meter is to be used strictly for temporary construction purposes only and then to be removed from the site, the applicant should indicate "temp only" on this form.
- The Association will issue a service order to set the meter upon receipt of the inspector's approval if the temporary or permanent meter inspection.
- Please allow 3 to 10 business days for the meter set to be completed.
- A deposit in the amount of an estimated 60-day bill may be required. Such deposit may be in addition to any advance, contribution, or guarantee provided for in the extension regulations.

## Meter Locations

- An electric meter will not be located in any area considered hazardous or inside where reading, testing, or servicing of the meter may become impracticable.
- A distance of 4' clearance must be maintained in front of the meter.
- The meter shall be located 5' to center of glass, above clear and level ground.
- Service disconnect shall be within 30" and accessible from meter housing.
- Meter housings are not provided by the Association. See Specifications for Meter Housings, Locations, and Installations.
- Only one meter will be issued per business. Strip malls and warehouses with multiple suites, units, or businesses will be allowed to have a commercial multi-metering configuration with one meter per business. Contact the Association Metering Department for detailed information.

UNDERGROUND COMMERCIAL  
SINGLE-PHASE (400 AMPS OR LESS)  
THREE-PHASE (200 AMPS OR LESS)

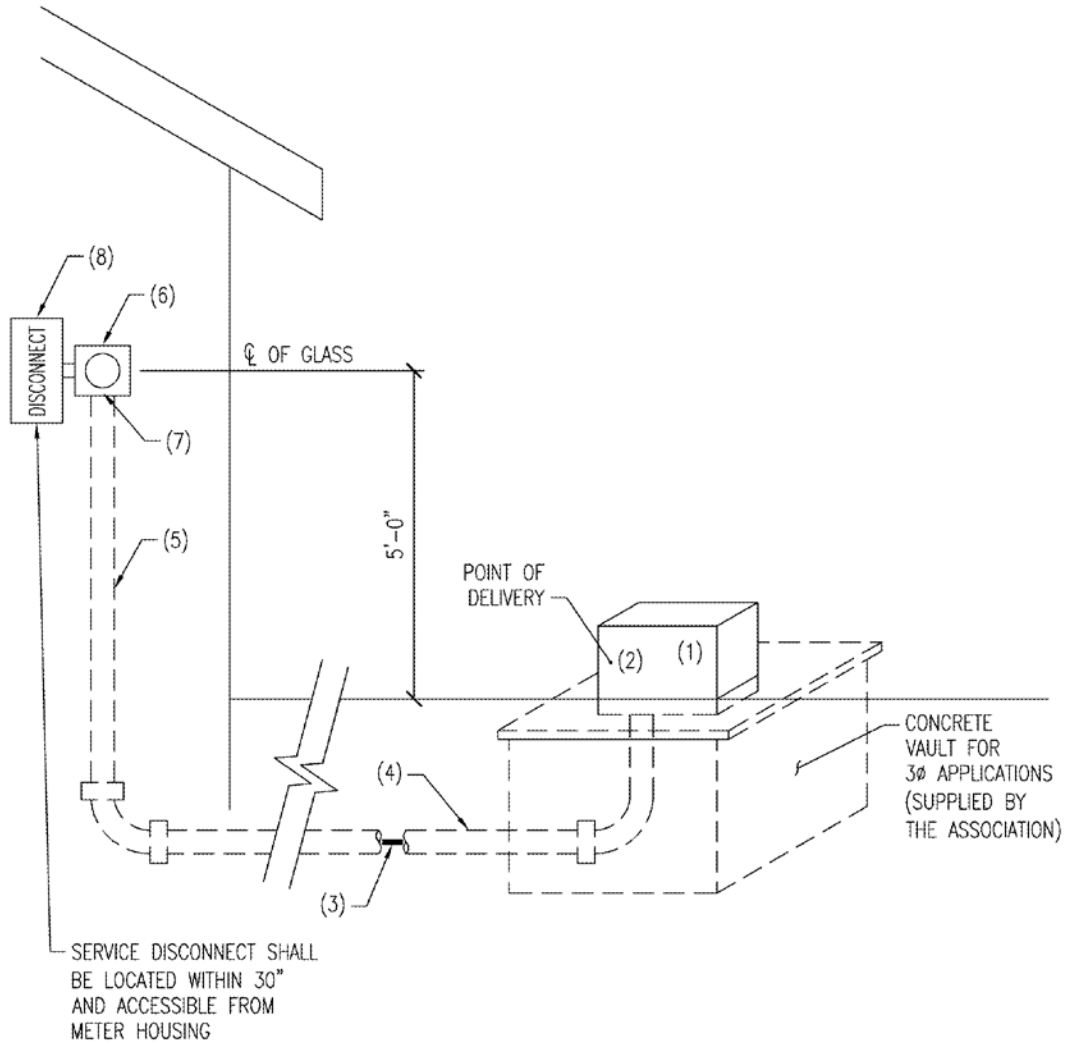

TABLE OF RESPONSIBILITY

KEY NO.	MATERIAL OR WORK DESCRIPTION	MATERIAL	INSTALLATION	OWNERSHIP AND MAINTENANCE
1	DISTRIBUTION FACILITIES (TRANS. OR PED.)	ASSOCIATION	ASSOCIATION	ASSOCIATION
2	CONNECTION, SOURCE	ASSOCIATION	ASSOCIATION	---
3	CONDUCTOR, SERVICE LATERAL	CUSTOMER	CUSTOMER	CUSTOMER
4	CONDUIT, HORIZONTAL, AND RELATED MATERIAL	CUSTOMER	CUSTOMER	CUSTOMER
5	CONDUIT SERVICE ENTRANCE	CUSTOMER	CUSTOMER	CUSTOMER
6	METER HOUSING LEVER BYPASS ON SAFETY - SEALED	CUSTOMER	CUSTOMER	CUSTOMER
7	CONNECTION, METERING HOUSING	---	CUSTOMER	---
8	DISCONNECT - MAGNETIC OR FUSED	CUSTOMER	CUSTOMER	CUSTOMER

SPECIAL NOTE: KEY NO. 2 - CONNECTORS ARE FURNISHED AND INSTALLED BY ASSOCIATION.

SP-3P-C

- If the service is underground to a meter pedestal, the meter is located within the meter pedestal, and the applicant will be required to install the secondary lateral to the building load.

METER PEDESTAL – COMMERCIAL  
SINGLE-PHASE (400 AMPS OR LESS)  
THREE-PHASE (200 AMPS OR LESS)

BREAKER TYPE (3R ENCLOSURE)

TYPE METER PEDESTAL	BREAKER TYPE	COMMENTS
MILBANK	BRYANT TYPE: BR/BJ LINE GE: TQDL 21, GE: TQD 22 ITE: QP OR QT LINE WESTINGHOUSE: CAZ LINE	200 AMP SERVICE 400 AMP SERVICE REQUIRES DOUBLE-BREAKER KIT TO BE INSTALLED BY ASSOCIATION PERSONNEL
SMALL DURHAM	WESTINGHOUSE TYPE: QUICKLAG P, BRYANT TYPE: BR, SQUARE D., HOME LINE ITE: QP	60 TO 125 AMP
STANDARD DURHAM	SAME AS MILBANK	200 AMP
LARGE DURHAM	SAME AS MILBANK	200 TO 400 AMP (400 AMP SERVICES REQUIRE TWO, 200 AMP BREAKERS)

NOTE:

If meter pedestal is a manufacturer other than noted above, please contact Association's Metering Department for additional breaker information.

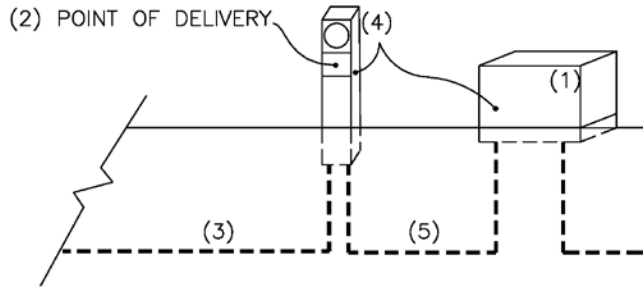

NOTES:

1. DOUBLE-BREAKER KIT FOR 400 AMP SERVICE ON MILBANK PEDESTALS ARE SUPPLIED AND INSTALLED BY ASSOCIATION.
2. IF DOUBLE-BREAKER KIT IS REQUIRED, BOTH BREAKER ASSEMBLIES MUST BE INSTALLED AND CENTERED PRIOR TO TEMP SERVICE.
3. FINAL CONNECTIONS FROM BREAKER TO METER MUST BE MADE BY ASSOCIATION'S PERSONNEL.
4. LEVER BYPASS REQUIRED FOR ALL COMMERCIAL SERVICES.

TABLE OF RESPONSIBILITY

KEY NO.	MATERIAL OR WORK DESCRIPTION	MATERIAL	INSTALLATION	OWNERSHIP AND MAINTENANCE
1	DISTRIBUTION FACILITIES	ASSOCIATION	ASSOCIATION	ASSOCIATION
2	BREAKER(S) IN PEDESTAL	CUSTOMER	CUSTOMER	CUSTOMER
3	CONDUCTOR, SERVICE LATERAL	CUSTOMER	CUSTOMER	CUSTOMER
4	METER PEDESTAL	ASSOCIATION	ASSOCIATION	---
5	SECONDARY WIRE	ASSOCIATION	ASSOCIATION	ASSOCIATION

0072-C

- If the service is overhead to the building, the meter will be located on the building.

OVERHEAD – COMMERCIAL  
SINGLE-PHASE (400 AMPS OR LESS)  
THREE-PHASE (200 AMPS OR LESS)

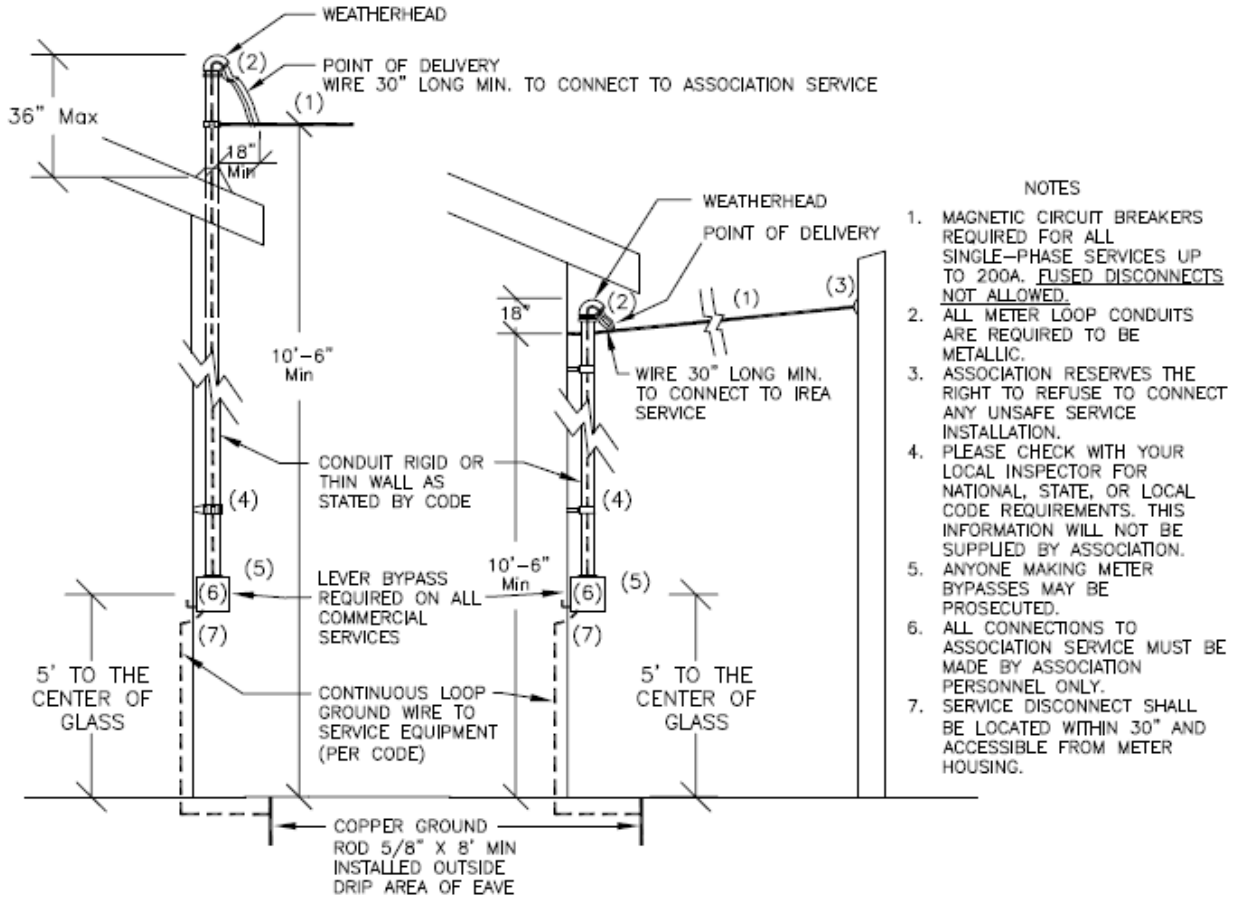

- NOTES
1. MAGNETIC CIRCUIT BREAKERS REQUIRED FOR ALL SINGLE-PHASE SERVICES UP TO 200A. FUSED DISCONNECTS NOT ALLOWED.
  2. ALL METER LOOP CONDUITS ARE REQUIRED TO BE METALLIC.
  3. ASSOCIATION RESERVES THE RIGHT TO REFUSE TO CONNECT ANY UNSAFE SERVICE INSTALLATION.
  4. PLEASE CHECK WITH YOUR LOCAL INSPECTOR FOR NATIONAL, STATE, OR LOCAL CODE REQUIREMENTS. THIS INFORMATION WILL NOT BE SUPPLIED BY ASSOCIATION.
  5. ANYONE MAKING METER BYPASSES MAY BE PROSECUTED.
  6. ALL CONNECTIONS TO ASSOCIATION SERVICE MUST BE MADE BY ASSOCIATION PERSONNEL ONLY.
  7. SERVICE DISCONNECT SHALL BE LOCATED WITHIN 30" AND ACCESSIBLE FROM METER HOUSING.

TABLE OF RESPONSIBILITY

KEY NO.	MATERIAL OR WORK DESCRIPTION	MATERIAL	INSTALLATION	OWNERSHIP AND MAINTENANCE
1	SERVICE DROP	ASSOCIATION	ASSOCIATION	ASSOCIATION
2	SERVICE CONNECTION	----	ASSOCIATION	----
3	SERVICE DROP CONNECTION	----	ASSOCIATION	----
4	CONDUIT AND CONDUCTOR TO SERVICE ENTRANCE	CUSTOMER	CUSTOMER	CUSTOMER
5	METER HOUSING WITH LEVER BYPASS	CUSTOMER	CUSTOMER	CUSTOMER
6	CONNECTION, METER HOUSING	----	CUSTOMER	----
7	DISCONNECT	CUSTOMER	CUSTOMER	CUSTOMER

002-C

- If the service is overhead to the meter pole and then underground to the building, the meter will remain on the meter pole, and the applicant will be required to install the secondary to the building.

METER POLE – COMMERCIAL OR INDUSTRIAL  
SINGLE-PHASE (400 AMPS OR LESS)  
THREE-PHASE (200 AMPS OR LESS)

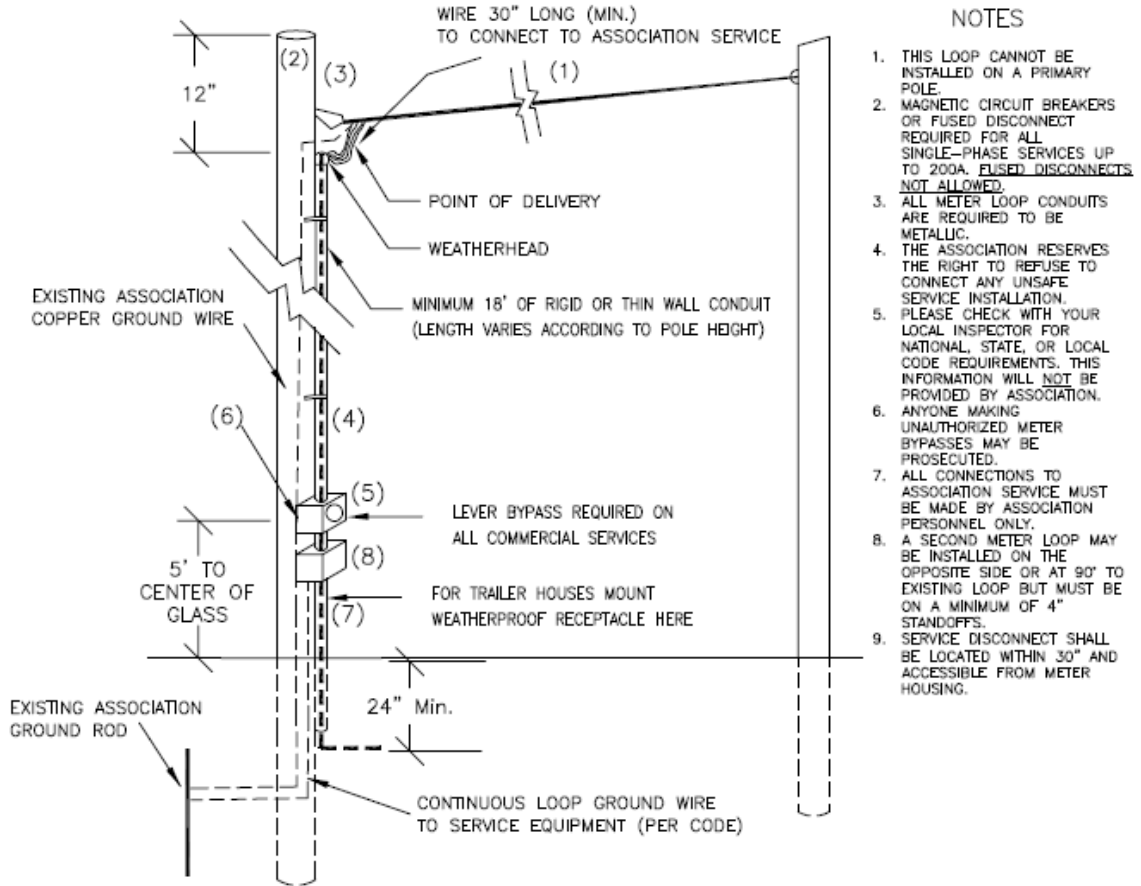

NOTES

1. THIS LOOP CANNOT BE INSTALLED ON A PRIMARY POLE.
2. MAGNETIC CIRCUIT BREAKERS OR FUSED DISCONNECT REQUIRED FOR ALL SINGLE-PHASE SERVICES UP TO 200A. FUSED DISCONNECTS NOT ALLOWED.
3. ALL METER LOOP CONDUITS ARE REQUIRED TO BE METALLIC.
4. THE ASSOCIATION RESERVES THE RIGHT TO REFUSE TO CONNECT ANY UNSAFE SERVICE INSTALLATION.
5. PLEASE CHECK WITH YOUR LOCAL INSPECTOR FOR NATIONAL, STATE, OR LOCAL CODE REQUIREMENTS. THIS INFORMATION WILL NOT BE PROVIDED BY ASSOCIATION.
6. ANYONE MAKING UNAUTHORIZED METER BYPASSES MAY BE PROSECUTED.
7. ALL CONNECTIONS TO ASSOCIATION SERVICE MUST BE MADE BY ASSOCIATION PERSONNEL ONLY.
8. A SECOND METER LOOP MAY BE INSTALLED ON THE OPPOSITE SIDE OR AT 90° TO EXISTING LOOP BUT MUST BE ON A MINIMUM OF 4" STANDOFFS.
9. SERVICE DISCONNECT SHALL BE LOCATED WITHIN 30" AND ACCESSIBLE FROM METER HOUSING.

TABLE OF RESPONSIBILITY

KEY NO.	MATERIAL OR WORK DESCRIPTION	MATERIAL	INSTALLATION	OWNERSHIP AND MAINTENANCE
1	SECONDARY	ASSOCIATION	ASSOCIATION	ASSOCIATION
2	POLE & GROUND ROD	ASSOCIATION	ASSOCIATION	ASSOCIATION
3	SERVICE CONNECTION	-----	ASSOCIATION	-----
4	CONDUIT AND CONDUCTOR TO SERVICE ENTRANCE	CUSTOMER	CUSTOMER	CUSTOMER
5	METER HOUSING WITH LEVER BYPASS	CUSTOMER	CUSTOMER	CUSTOMER
6	CONNECTION, METER HOUSING	-----	CUSTOMER	-----
7	CONDUIT AND CONDUCTOR	CUSTOMER	CUSTOMER	CUSTOMER
8	WEATHERPROOF MAIN DISCONNECT DEVICE	CUSTOMER	CUSTOMER	CUSTOMER

900q-c

- CT/PT metering is required for single-phase greater than 320amp continuous or 400 amp peak loads and three-phase greater than 200 amp. See Current Transformer – CT and Potential Transformer – PT Metering.

## EUSERC SINGLE METER (ELECTRIC UTILITY SERVICE EQUIPMENT REQUIREMENT COMMITTEE)

**NOTES:**

1. ENCLOSED BY LOCKABLE DOORS.
2.  HINGED DOORS  
CT'S & PT'S ARE LOCATED  
BEHIND METER AND  
TEST SWITCH.
3. LOCATED OUTDOORS ONLY
4. ENCLOSURE: NEMA TYPE 3R

3Ø 13 TERMINALS  
1Ø 8 TERMINALS

1Ø 240 VOLT OVER 400 AMP  
3Ø 208 VOLT OVER 200 AMP  
3Ø 480 VOLT OVER 200 AMP

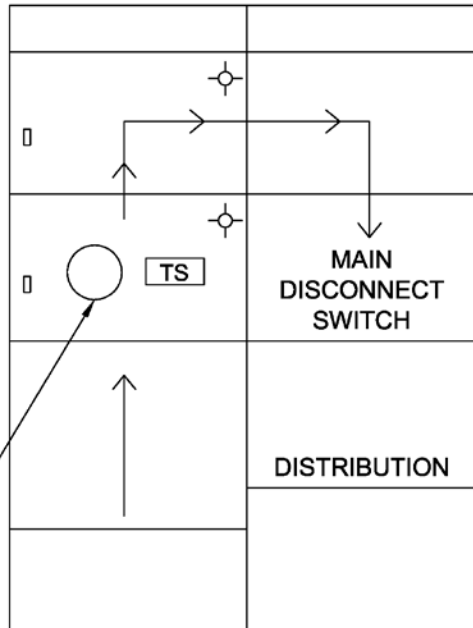

\*  HOT SEQUENCE  
TO ASSOCIATION  
TRANSFORMER

## Multiple Meter Installations

### Nonresidential

On nonresidential multi-meter panels, the centerline of meters shall be a minimum of 3' and a maximum of 6'-6" above finished grade or floor. The minimum spacing between socket centers shall be 12" horizontally and 12" vertically.

Meters shall be protected from mechanical damage. Factory-built multi-meter equipment shall be approved by the Association Meter Department.

#### MULTIPLE METER SINGLE-PHASE COMMERCIAL (200 AMPS OR LESS PER METER)

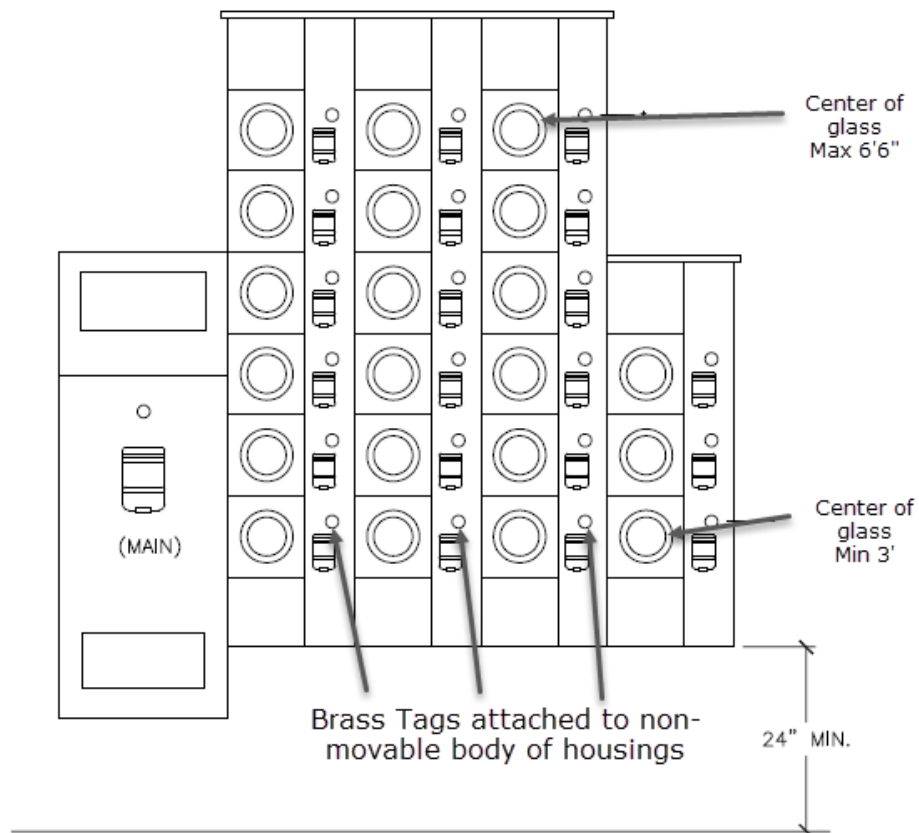

## COMMERCIAL MULTI-METERING FOR EUSERC APPLICATIONS

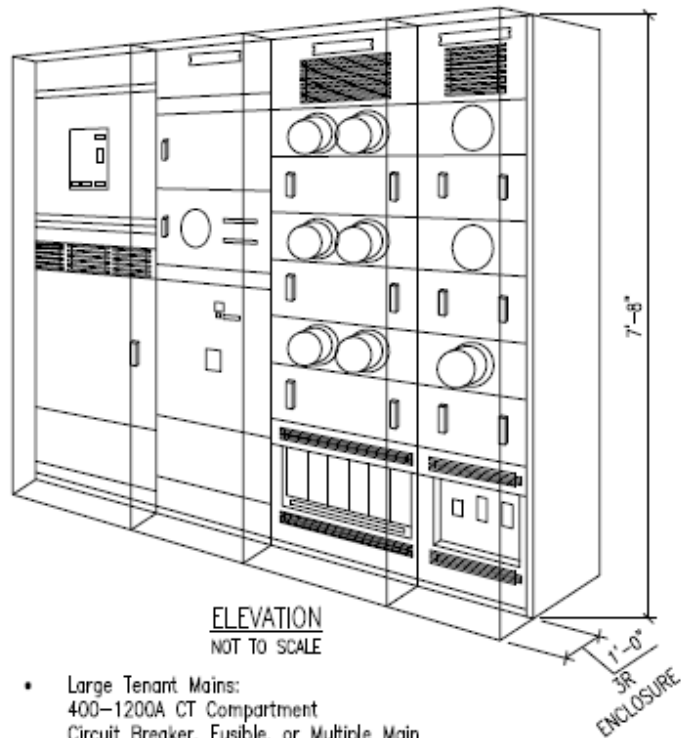
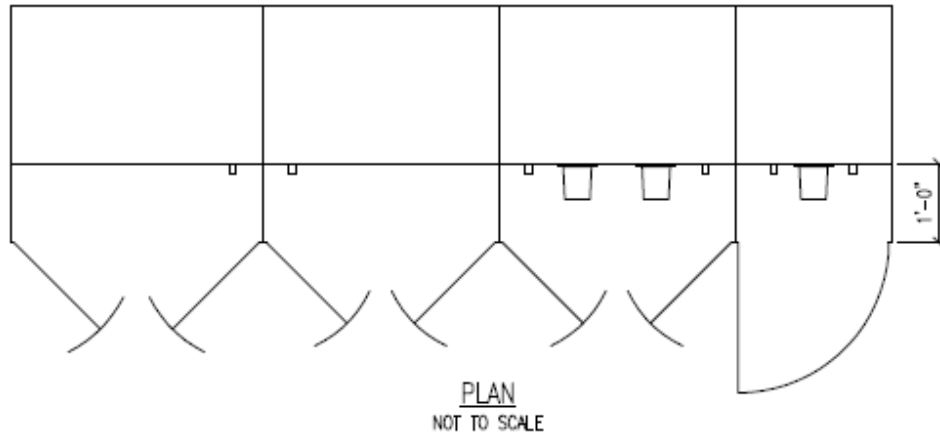

- UL Listed Service Entrance
- Service:
  - 120/240V 1Ø3W ac
  - 120/240V 1Ø4W ac Restricted\*
  - 240/120V 3Ø4W ac Δ
  - 208Y/120 3Ø4W ac
  - 480Y/277V 3Ø4W ac
- Ampacity 200–4000A
- SCCR 100,000A rms Symmetrical
- Bussing:
  - Aluminum (Standard)
  - Copper (Optional)
- Enclosure:
  - NEMA Type 3R
- Hot Sequence Metering: EXCEPTION  
6 HANDLE RULE
- Mains:
  - Underground Pull Section 400–4000A
  - Circuit Breaker 400–4000A
  - Fusible Switch 400–4000A

- Large Tenant Mains:
  - 400–1200A CT Compartment
  - Circuit Breaker, Fusible, or Multiple Main
- Meter Sections:
  - 3–Socket or 6–Socket
  - Circuit Breaker or Fusible
- Meter Sockets:
  - 200A Continuous (5–Jaw or 7–Jaw)
  - Plug-On Construction

\*Available only on existing services – may require upgrade to 120/208 or 277/480 voltage

4 panels–C

## Cable Limits for Three-Phase Pad-Mounted Transformers

Twelve (12) runs is the maximum number of secondary conductors allowed for transformer sizes 45KVA to 3000KVA.

### Voltages

The Association offers their customers the voltages shown in the table below.

Service Type	Voltage
Three-phase	120/208V, 4-wire 277/480V, 4-wire
Primary Three-Phase	7200/12470V, 4-wire

\*Available for loads to a maximum demand of 100kW. Larger loads may be served, if determined feasible by an Association engineer. All motors must be rated 10 HP or less.

## Fault Current Levels and Standard KVA Size Transformers

The most commonly used transformers installed by the Association are shown in the tables below. Tables also show the maximum available short-circuit current at the transformer's secondary connection point.

Maximum short circuit current in amps for single-phase pole mounted transformers

Secondary Voltage	KVA	240 V Windings		120 V Winding	
		Min. % Z	Fault Current	Min. % Z	Fault Current
120/240	10	1.5	2778	1.5	5556
120/240	15	1.5	4167	1.5	8333
120/240	25	1.5	6944	1.5	13889
120/240	37.5	1.5	10417	1.5	20833
120/240	50	1.5	13889	1.5	27778

Maximum short circuit current in amps for single-phase pad mounted transformers

Secondary Voltage	KVA	240 V Winding		120 V Winding	
		Min. % Z	Fault Current	Min. % Z	Fault Current
120/240	15	1.5	4167	1.5	8333
120/240	25	1.5	6944	1.5	13889
120/240	37.5	1.5	10417	1.5	20833
120/240	50	1.5	13889	1.5	27778
120/240	75	1.5	20833	1.5	41667
120/240	100	1.5	27778	1.5	55556
120/240	167.5	1.5	46528	1.5	93056

**Maximum short circuit current in amps for Three-single phase pole mounted transformer bank**

Secondary Voltage	KVA	208 V Winding		120 V Winding	
		Min. % Z	Fault Current	Min. % Z	Fault Current
120/208	10	1.5	1850	1.5	3208
120/208	15	1.5	2776	1.5	4811
120/208	25	1.5	4626	1.5	8019
120/208	37.5	1.5	6939	1.5	12028
120/208	50	1.5	9252	1.5	16038

**Maximum short circuit current in amps for Three-phase pad mounted transformers**

Secondary Voltage	KVA	3 Phase L-G	
		Min. % Z	Fault Current
120/208	75	1.5	13879
120/208	112.5	1.5	20725
120/208	150	1.5	27757
120/208	225	1.5	41636
120/208	300	1.5	55514
120/208	500	1.5	92524
120/208	750	2.5	83272
120/208	1000	5.0	55514

Secondary Voltage	KVA	480 V Winding		277 V Winding	
		Min. % Z	Fault Current	Min. % Z	Fault Current
277/480	10	1.5	802	1.5	1390
277/480	15	1.5	1203	1.5	2084
277/480	25	1.5	2005	1.5	3474
277/480	37.5	1.5	3007	1.5	5211
277/480	50	1.5	4009	1.5	6948

Secondary Voltage	KVA	3 Phase L-G	
		Min. % Z	Fault Current
277/480	75	1.5	6014
277/480	112.5	1.5	8981
277/480	150	1.5	12028
277/480	225	1.5	18042
277/480	300	1.5	24056
277/480	500	1.5	40094
277/480	750	2.5	36084
277/480	1000	4.0	30070
277/480	1500	4.5	40094
277/480	3000	5.0	72169

## Specifications for Single & Three-Phase Self-Contained Meter Housings (120/240V 1Ø, 3-Wire; 120/208V, 3Ø, and 277/480V 3Ø 4-Wire)

- Housings shall be constructed from metal in accordance with the latest revision of Underwriters' Laboratories (UL) Standard No. 414 for meter sockets.
- Each socket on line-side compartment shall be equipped so proper sealing of the socket can be maintained by padlock.
- After installation and sealing are completed, the socket shall not have any openings except as permitted by NEMA Type 3R construction.
- All meter housings shall be UL listed and labeled, and they shall be installed and used in accordance with their labeling.
- Meter housing installations shall be installed per National Electric Code (NEC) Standards and shall be enforced by the local inspection authority.
- Center of glass on meter housing shall be located five feet (5') above finished grade.
- All commercial applications will have a meter socket with a heavy-duty locking jaw with lever-type bypass or meet the EUSERC Standards for commercial metering with safety sockets.
- All sockets (including CT/PT installations) will be permanently labeled with an etched metal tag or permanent tag noting the service location that it feeds, on the body of housing; not on the removable panel.
- Maximum amp size to be metered by a self-contained 3Ø meter will not exceed 200 amps.
- All existing services that are changed or upgraded because of increased loads, transformer size, wire size, or reconstruction will adhere to the Association's current Standards.
- All 3Ø polyphase sockets will have a seven-terminal mounting block with a heavy duty 200-amp locking jaw with lever-type bypass or meet the EUSERC Standards for commercial metering with safety sockets.
- All 3Ø customers will provide their own single-phase protection.

- All 1Ø meter housing will require lever-type-bypass.
- Maximum amp size to be metered by a self-contained 1Ø meter will not exceed 320amp continuous or 400amp peak loads. All single-phase services in excess of 200 amps require a class 320 meter and lever bypass meter housing unless preapproved by the Association. Class 320 meters have a maximum continuous load rating of 320 amps. Continuous loads greater than 320 amps will require CT metering which will adhere to the EUSERC Standards.
- Self-contained meter housing shall have a spare access hole. The spare access hole shall be capped and secured from the inside of the meter housing with a metal cap such that the cap cannot be removed from the outside of the housing. The spare access hole shall be sized at 2 inches for 200A and above rated meter housings, or 1.5 inches for 150A and below meter housings.

Additional approval will be given to meter/load center combinations as well as multiple combinations, which meet all other provisions for commercial/3Ø meter housings.

It is understood that the Association's approval does not mean approval in any area where there may be a conflict with any national or local code, and the local inspecting body will need to approve and will have the final authority.

It is also understood that in case of a disaster, the Association will not have spare parts and will not be responsible for the repair.

### **Specifications for Meter Location and Installation**

Subject to Association Meter Department personnel approval, the customer shall provide and maintain, without cost to the Association, an easily accessible meter location on or within the premises to be supplied service. All locations must comply with Association Rates and Regulations.

Where meters, originally installed in accessible locations satisfactory to the Association, are rendered inaccessible by virtue of alterations or new construction by the owner of the premises or his agents, such meters shall be reinstalled at a point designated by the Association at the expense of the property owner.

The location of meters and metering equipment shall be designated by the Association. No wiring dependent upon the meter location should be started until such location has been approved.

## **Meters**

- Meters shall be installed outdoors in accordance with rules governing outdoor meter installations. Meters and EUSERC cabinets are to be installed outside the building either free standing (EUSERC cabinet) or against an exterior wall (EUSERC cabinet or meter) allowing unobstructed access by the Association's personnel.
- A minimum of 3' unobstructed and level working space in front of the cabinet is also required.
- The cabinet or meter may NOT be installed in an interior room, courtyard, or any other structure that could possibly have a lockable entry way.
- If the EUSERC cabinet, metering, and main disconnect are not installed in a proper location and manner, the Association will refuse service. Major changes may be required at the customer's cost and delay the service connection.
- Meter mounting and associated equipment shall be mounted securely and plumb. Where attachment is made to masonry, concrete, or plaster walls, expansion bolts, plugs, or anchors shall be used.
- Meter mountings shall not be placed in a location where meter reading or servicing may become impracticable or may cause damage to any part of the customer's premises.
- Meter housing must be located within 30" of load side disconnect.

## **Line-side Conductors**

- The line-side conductors in meter mounting devices shall be required to be separated from the load-side conductors by means of permanent barrier.
- Access to the line-side conductors shall be sealable.
- No conductors other than line-side conductors shall be permitted in line-side conduits, troughs, or lug landings.
- All line-side (unmetered) conductors must be in a continuous length of conduit from the point of delivery to the meter mounting device.

- The use of line-side (ahead of the meter) disconnects or other open devices are not permitted with exception to 277/480V self-contained commercial accounts and/or multiple-meter stacks following the NEC 6 handle rule.
- Association Distribution Operations personnel must approve the location of any ahead-of-the-meter devices.
- An approved location will be limited to installation in secured switch gear or on the same surface wall directly ahead and within 24” of the meter.

Meter location, point of delivery, and service disconnect will be determined by the Association in accordance with standard practices, including the National Electrical Code, and will be accessible to the Association’s service personnel at all times.

**Three-Phase Services: 120/240V, Four-Wire Delta**

In addition to the requirements for all three-phase services, the high-leg (power leg) shall be connected through the right-hand terminals of the socket. Applicants upgrading service may be required to convert to 120/208 or 277/480 voltage. **(Restricted – available only for existing services)**

**Three-Phase Self- Contained Services: 277/480V**

An accessible meter disconnect switch before each meter base/socket and a safety socket with a manual bypass is required. Meter disconnect switch shall not be overcurrent protected. Additionally, a service disconnect is required after the meter.

<b>Meter Form Socket/Base Types</b>								
Voltage	Wires	Service Amps	# of Terminals	Meter Socket Config	By-Pass Required	Sequence	Meter Socket Requirement	EUSERC Drawings
<u>Single Phase</u>								
120/240	3	1 - 200 A	4	A	<u>Yes*</u>	Hot	Lever bypass or safety socket required (*Not required on residential services).	
120/240	3	201 - 400 A	4	A	<u>Yes</u>	Hot	Lever bypass or safety socket required	
120/240	3	401 - 1000 A	8	B	No	Hot	see EUSERC.org	319 - 327, 354
120/240	3	1001 - 3000 A	8	B	No	Hot	see EUSERC.org	319 - 327, 354

Poly Phase								
120/208	3	1 - 200 A	5	C	<u>Yes*</u>	Hot	5th Terminal in 9 o'clock position. Lever bypass or safety socket required (*Not required on residential services).	
120/208	4	1 - 200 A	7	D	<u>Yes</u>	Hot	Lever-bypass or safety socket required	
120/208	4	201 - 1000 A	13	E	No	Hot	see EUSERC.org	319 - 327, 354
120/208	4	1001 - 3000 A	13	E	No	Hot	see EUSERC.org	319 - 327, 354
120/208	4	> 3000 A	13	E	No	Hot	see EUSERC.org	319 - 327, 354
277/480	4	1 - 200 A	7	D	<u>Yes</u>	Cold	Lever-bypass or safety socket required	
277/480	4	201 - 1000 A	13	E	No	Hot	see EUSERC.org and IREA Drawings 3-5	319 - 327, 354
277/480	4	1001 - 3000 A	13	E	No	Hot	see EUSERC.org and IREA Drawings 3-5	319 - 327, 354
277/480	4	> 3000 A	13	E	No	Hot	see EUSERC.org and IREA Drawings 3-5	319 - 327, 354
Note: Existing services needing repair not covered above, contact Metering Department								

\* Meter Base/Socket Configurations

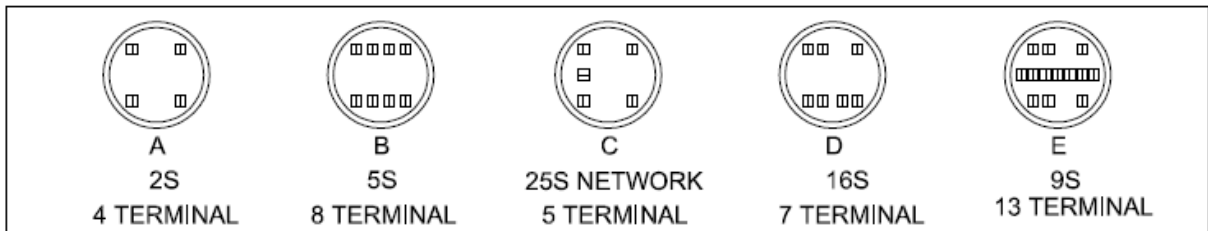

\*RINGLESS REQUIRED ON ALL RESIDENTIAL  
 \*RINGLESS PREFERRED ON COMMERCIAL  
 \*(SEE FULL BOOK)

### **Three-Phase Services, Above 200 Amps**

All three-phase services above 200 amps will require EUSERC specification switchgear, which will include a pull section, metering section and disconnect section. NEMA 3R rated enclosures will be on all sections with double locking device provided for joint access to applicable sections. (See Drawings 325, 354 of EUSERC information). Any 277/480 volt service will have an additional width to accommodate the placement of Potential Transformers attached to a removable PT pan. (See Drawing 326 of EUSERC information & Instrument-Transformer Compartment Drawings and IREA Drawings 3-5) All EUSERC systems will be hot sequenced per EUSERC SINGLE METER drawing.

Fire pumps fed from EUSERC switchgear may be tapped ahead of the main disconnect, but shall have a dedicated labeled disconnect. Fire pump installations shall meet NEC and local standards.

### **Manufacturer Drawings Required for Services Over 200 Amps**

Manufacturer drawings shall be submitted to the Association for approval for all switch board metering prior to shipment from manufacturer.

## CURRENT TRANSFORMER (CT) / POTENTIAL TRANSFORMER (PT) METERING

---

Current and potential transformers provide the intelligence for measuring or metering power flows, such as large amperes flowing in a high-voltage circuit. More specifically, the Association will use CT's and PT's on services as listed below:

- CT - 120/208V, three-phase larger than 200 amp service entrance
- 120/240V, single-phase larger than 400 amp\* service entrance  
\*320 amp continuous load or 400 amp Peak

CT/PT - 277/480V, three-phase larger than 200 amp service entrance

**If you are requiring this type of service, please contact the Association Metering Department for installation procedures, guidelines, and equipment specifications.**

EUSERC standards are used when a service requires the use of CT (Current Transformer) metering. It is recognized by many safety agencies, including NEMA, UL and ETL Testing Labs. The equipment used is handled by many manufacturers, including AMP, Eaton/Cutler-Hammer, GE, Siemens, and Square D. It is a standard used by 80 utilities in 14 states.

EUSERC is required when an expected load (amperage) exceeds the maximum limit for which self-contained metering is capable of handling. For a single-phase service, the maximum limit is 400 amps. For a three-phase service, the maximum limit is 200 amps.

The benefits of following EUSERC standards are many:

- Due to the metering being enclosed and protected, less theft and vandalism occurs, and there are no environmental conditions.
- Since EUSERC is standardized with simplified construction, fewer wiring errors can occur which reduces billing errors due to incorrect metering.
- It is more aesthetically pleasing with one cabinet that is inter-connectable and with everything enclosed and hidden from view.
- The time and labor involved in installing a EUSERC cabinet is often much less than other forms of CT metering, resulting in a savings to the customer.

The cabinet is a *switchboard* which is usually 90 inches tall, 26 inches deep, and can range from 38 to 90 or more inches in width. It has a pull section and a metering section on the line side, and a main disconnect switch on the load side. This is all enclosed in the self-contained switchboard, which is a rain tight enclosure with

exterior locking doors, protecting it from the elements, vandalism, etc. Please note that the customer's main disconnect switch **MUST** be within the EUSERC cabinet.

It is to be installed outside the building, either free standing, or against an exterior wall, allowing unobstructed access by Association personnel. At least a three-foot clear, level unobstructed working space beyond the door when fully open at 90-degree position is also required.

Please note that the cabinet may **NOT** be installed in an interior room, courtyard, or any other structure that could possibly have a lockable entryway. Please be aware that if the EUSERC cabinet is not installed in a proper accessible location, the customer will be required to make the necessary changes at their cost, and a delay in receiving electrical service may be inevitable.

**CT/PT Requirements:**

- CT/PT cabinets must be furnished and installed by the customer. Located outside in accordance with the Association's policies, and meet EUSERC Standards.
- Metering connections are performed by the Association's personnel.
- Association will install a lock on CT/PT cabinet. Customer shall supply a double locking device for joint access.
- CTs/PTs are supplied by the Association (prepaid by customer) and installed by the customer's electrician.
- Construction must follow national, state or local code requirements.
- Polarity of CTs toward source.
- All existing services that are changed or upgraded because of increased loads, transformer size, wire size, or reconstruction will adhere to the EUSERC Standards.
- All sockets will be permanently labeled with an etched metal tag or permanent tag approved by the Association Meter Department personnel noting the service location that it feeds, on the body of housing; not on the removable panel.

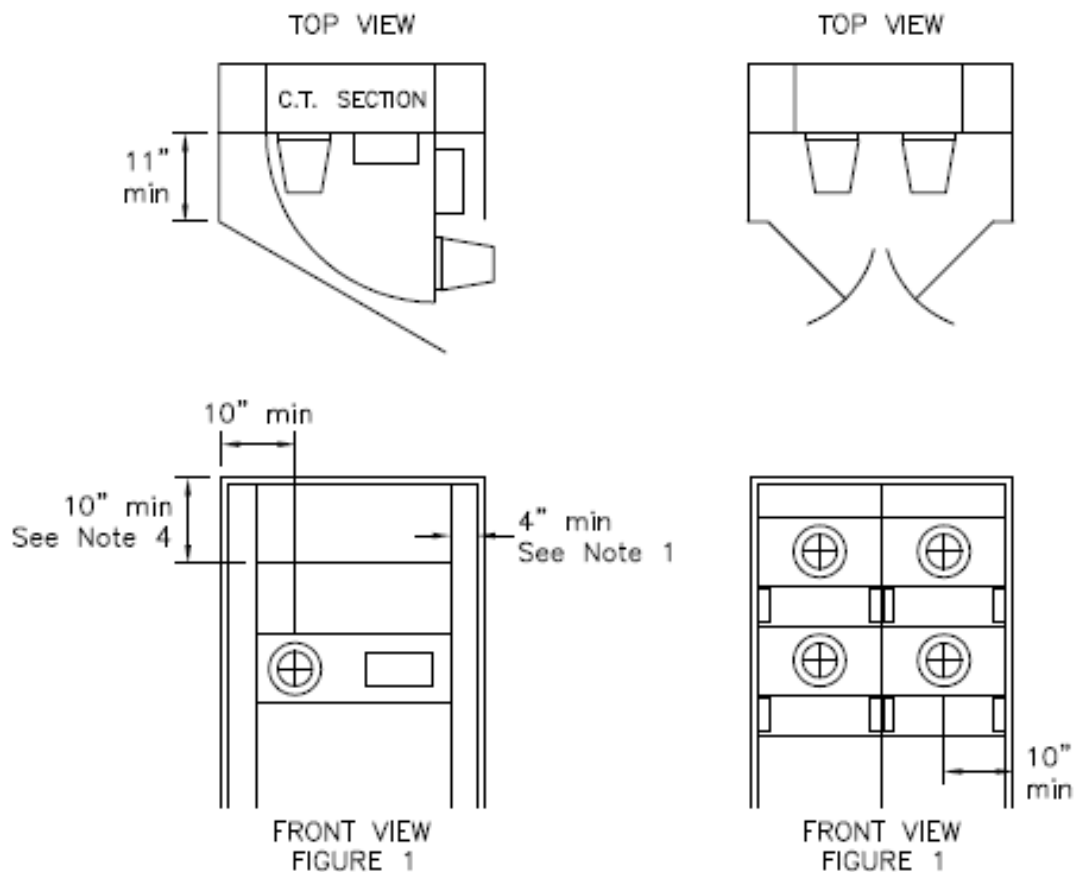

NOTES:

1. Hinged meter panel shall be capable of being opened 90° with meter and test facilities in place, and provide the following clearances to any obstruction – 11" at the meter socket and 4" at the test-switch-slotted opening.
2. Meter panels, either socket or blank, shall not be hinged to a hinged filler panel. Non-hinged filler panels shall not extend into the required instrument-transformer compartment access opening.
3. Enclosure doors providing access to utility compartments (i.e., metering sections and pull sections) shall be:
  - a. Equipped with a device to secure the doors in the open position at 90° or more.
  - b. Secured in the closed position with a single, handle-operated, latching system. When provided with a locking means, each door, or set of doors, shall be equipped with an approved double-locking device, accepting padlocks with a  $\frac{5}{16}$ " lock shaft, to allow access by both the serving utility and the customer.
4. Dimension may be reduced if the service sections supplied from horizontal cross-bussing or bus duct.
5. See EUSERC.org for details (DWG NO. 354)

120/208 VOLTS

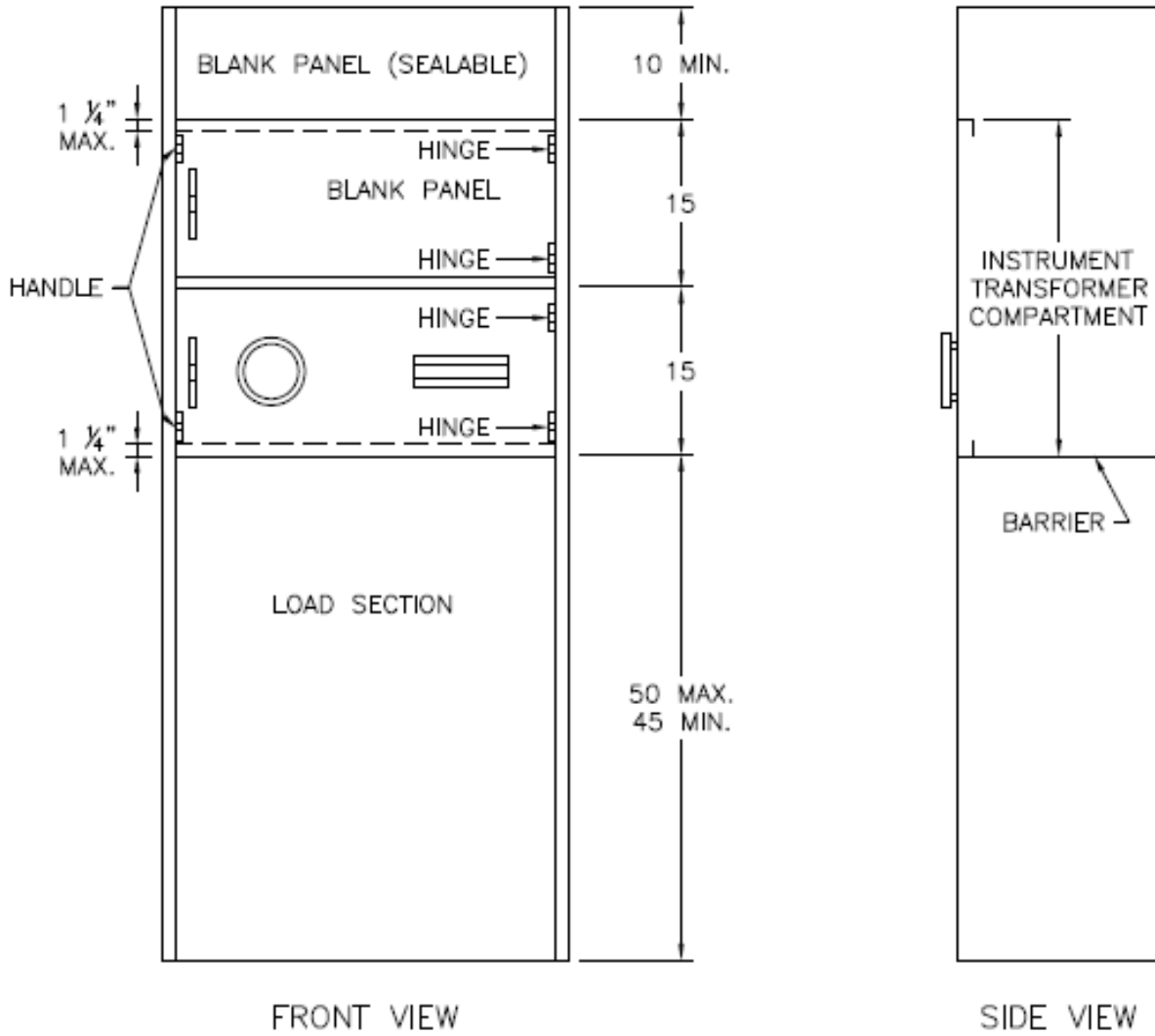

- NOTES:
1. Shown without 3R doors.
  2. See EUSERC.org for details (DWG NO. 325)

277 / 480 VOLTS

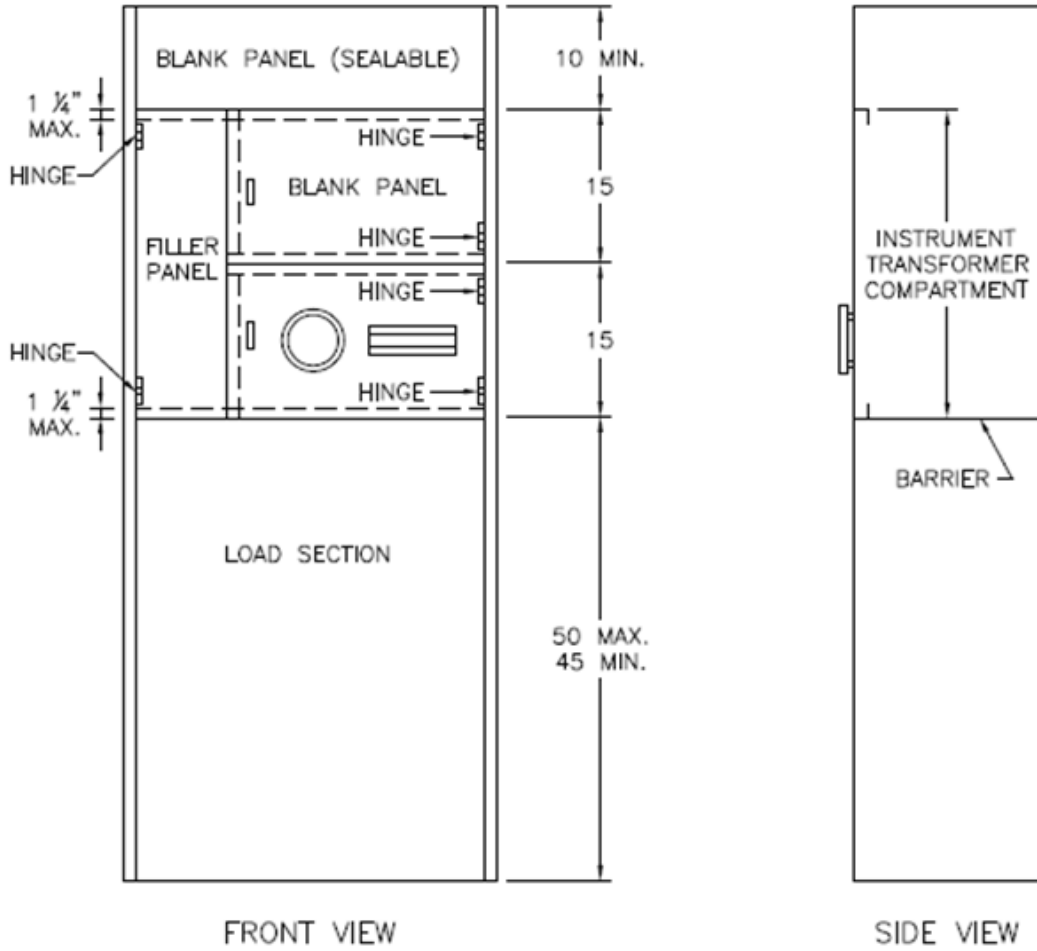

NOTES:

1. Shown without 3R doors.
2. See EUSERC.org for details (DWG NO. 326)

# INSTRUMENT-TRANSFORMER COMPARTMENT WITH P.T. MOUNTING PAN

0-1000 AMPERES, 480 VOLTS SERVICE ONLY, 3 $\phi$  3-WIRE  
AND 3 $\phi$  4-WIRE

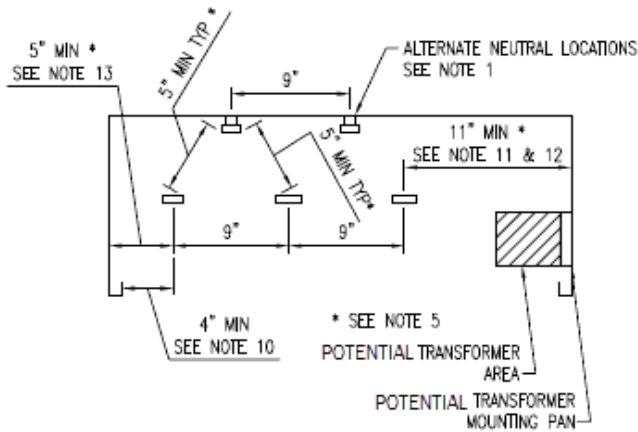

TOP VIEW

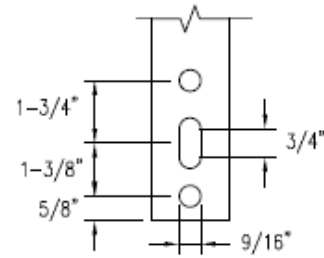

BUS DRILLING DETAIL  
TYPICAL 6 LOCATIONS

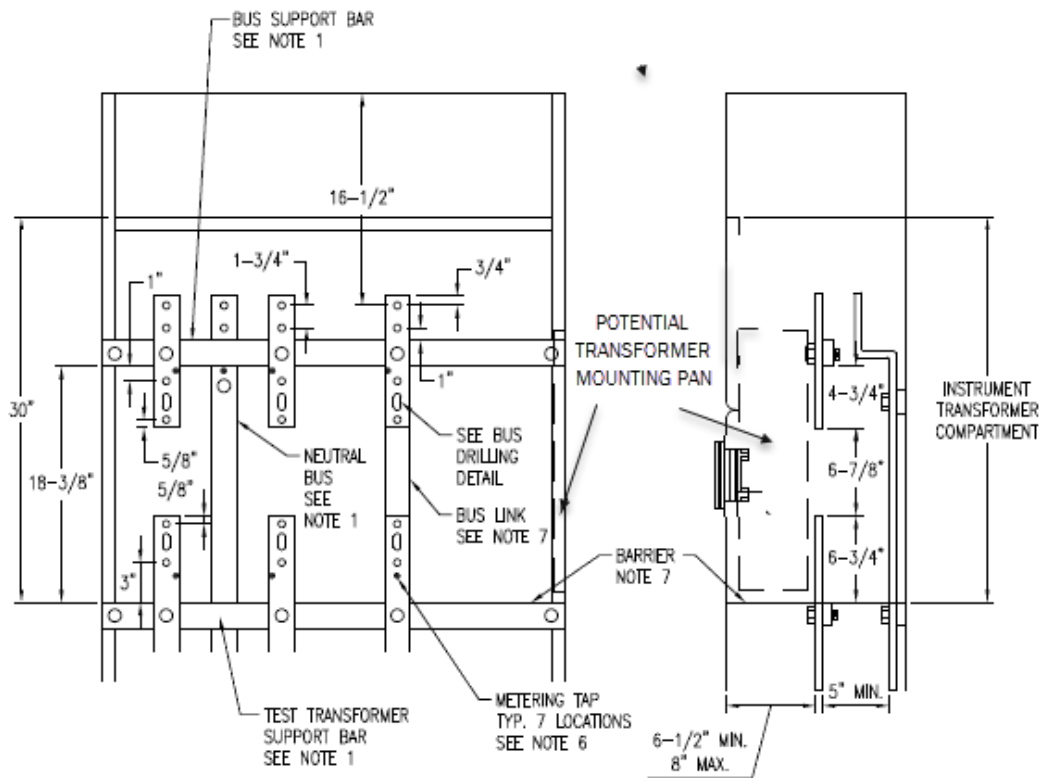

FRONT VIEW

SIDE VIEW

NOTES:

1. Bus arrangements and supports shall be provided as shown, except the neutral bus may be located at either side or on either side or on either side wall (Note: Neutral bus not required for 3-phase, 3-wire services). Bus supports shall be constructed of a continuous bar or insulating material and shall be rigid to prevent misalignment of the bus units with the cables in place.
2. The bus units may be supplied from the top or bottom and shall be anchored to prevent turning. Bus units shall be constructed of rectangular bus and when laminated shall have no space between laminations. Bus dimensions shall be provided as follows:
  - Minimum: ¼ inch x 2 inches
  - Maximum: ¾ inch x 2 inches
3. When the compartment is supplied from horizontal cross-bussing, the bussing shall pass through the compartment or in the sealed area above the compartment.
4. Except for conductors supplying the instrument-transformer compartment, no other conductors or devices shall be installed in, or routed through, the compartment or the sealed area above the compartment.
5. A clear unobstructed work space shall be provided around the current-transformer bus units from the barrier to the upper support bar.
6. Taps for attachment of meter wiring shall be provided as follows:
  - a. One tap on each upper and lower phase bus unit with a 10-32 screw and washer provided for each phase bus in either the upper or lower position.
  - b. One tap on the neutral bus as shown, or when the compartment is supplied from cross bussing a tap may be provided on the neutral cross-bus, or on a bus bar extension provided from the neutral cross-bus. A 10-32 screw and washer shall be provided for the neutral bus. Tap locations shall be centered between phase bus units, or at either side, and shall be readily accessible under energized conditions and with current-transformer.
7. The barrier shall be constructed of a rigid insulating material resistant to ARC tracking, and shall be secured in place with a maximum deflection of ½ inch from an applied force of 25 pounds downward. Openings in the barrier (i.e., peripheral gaps around barrier, cutouts around bus bars, and hole diameters provided for ventilation) shall not exceed 3/8 inch. The barrier shall be attached with nonconductive fasteners.
8. A removable link shall be installed in the right side phase bus for 3-phase, 3-wire service.
9. The power leg bus for a 4-wire delta service shall be identified by an orange outer finish, or by tagging or other effective means.
10. Dimensional measured to inside edge of the compartment access opening.
11. When line to line voltage exceeds 250 volts, the compartment width shall be increased by 6 inches minimum to allow for installation of potential transformer. The C.T. bus stubs shall remain at their original dimensions allowing this extra width to be clear area.
12. Minimum distance is measured from the P.T. pan mounting surface to bus center line.
13. Alternate location of potential transformer area.

# INSTRUMENT-TRANSFORMER COMPARTMENT WITH P.T. MOUNTING PAN

1000-3000 AMPERES, 480 VOLTS SERVICE ONLY. 3 $\phi$  3-WIRE AND 3 $\phi$  4-WIRE

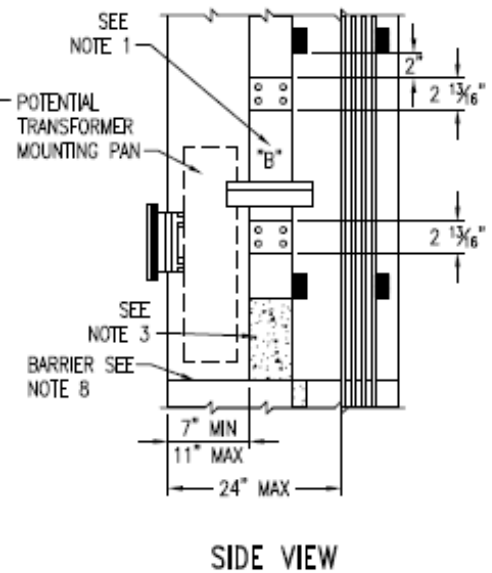
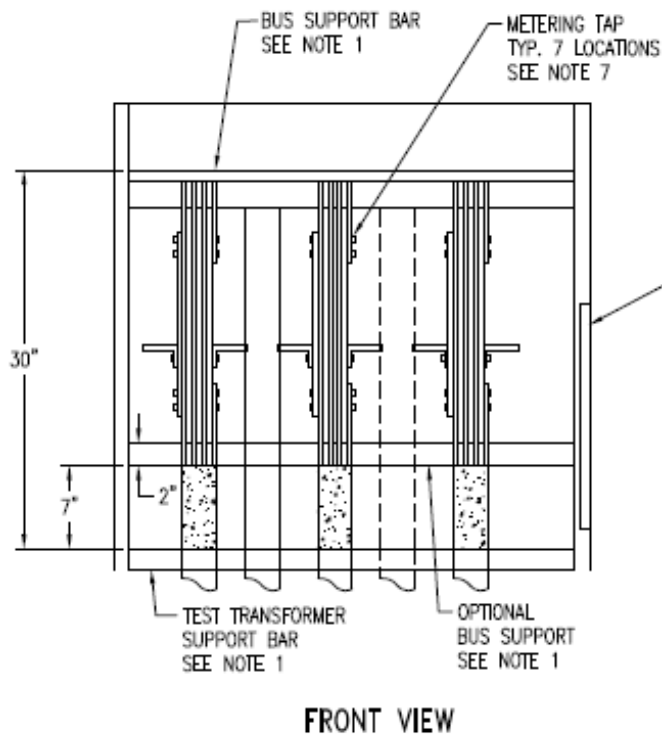
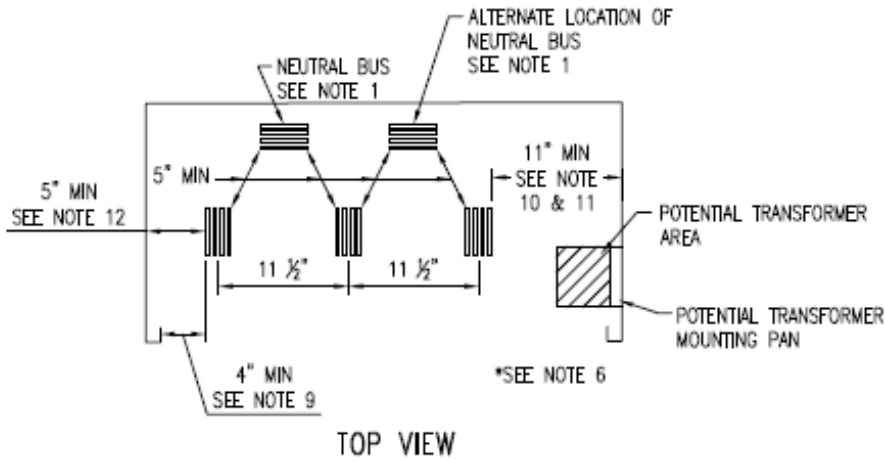

IREA Drawing #4

NOTES:

1. Bus arrangements and supports shall be provided as shown, except the neutral bus may be located at either side or on either side or on either side wall (Note: Neutral bus not required for 3-phase, 3-wire services). Bus supports shall be anchored so that buses will remain in position when section "B" is removed. Bus supports shall be constructed of a continuous bar or insulating material.
2. Bus units may be supplied from the top or bottom, and shall be constructed of rectangular bus. Maximum allowable bus size shall be four ¼-inch x 4-inch bars spaced ¼ inch.
3. Bus units shall be insulated as shown and the insulating material shall be rated for the serving voltage. Round bus corners as necessary to prevent damage to insulation.
4. When the compartment is supplied from horizontal cross-bussing, the bussing shall pass through the compartment or in the sealed area above the compartment.
5. Except for bus supplying the instrument-transformer compartment, no other conductors or devices shall be installed in, or routed through, the compartment or the sealed area above the compartment.
6. A clear unobstructed work space shall be provided around the current-transformer bus units from the barrier to 2 inches above the removable current-transformer bus sections ("B").
7. A 10-32 tap for attachment of meter wiring shall be provided as follows:
  - a. One tap on each upper and lower phase bus unit with a 10-32 screw and washer provided for each phase bus in either the upper or lower position.
  - b. One tap on the neutral bus as shown, or when the compartment is supplied from cross bussing a tap may be provided on the neutral cross-bus, or on a bus bar extension provided from the neutral cross-bus. A 10-32 screw and washer shall be provided for the neutral bus. Tap locations shall be centered between phase bus units, or at either side, and shall be readily accessible under energized conditions and with current-transformer in place.
8. The barrier shall be constructed of a rigid insulating material resistant to ARC tracking, and shall be secured in place with a maximum deflection of ½ inch from an applied force of 25 pounds downward. Openings in the barrier (i.e., peripheral gaps around barrier, cutouts around bus bars, and hole diameters provided for ventilation) shall not exceed 3/8 inch. The barrier shall be attached with nonconductive fasteners.
9. Dimensions measured to inside edge of the compartment access opening.
10. When line to line voltage exceeds 250 volts, the compartment width shall be increased by 6 inches minimum to allow for installation of voltage transformers. The C.T. bus stubs shall remain at the original dimensions allowing this extra width to be clear area.
11. Minimum distance is measured from the P.T. pan mounting surface to bus center line.
12. Alternate location of potential transformer area.

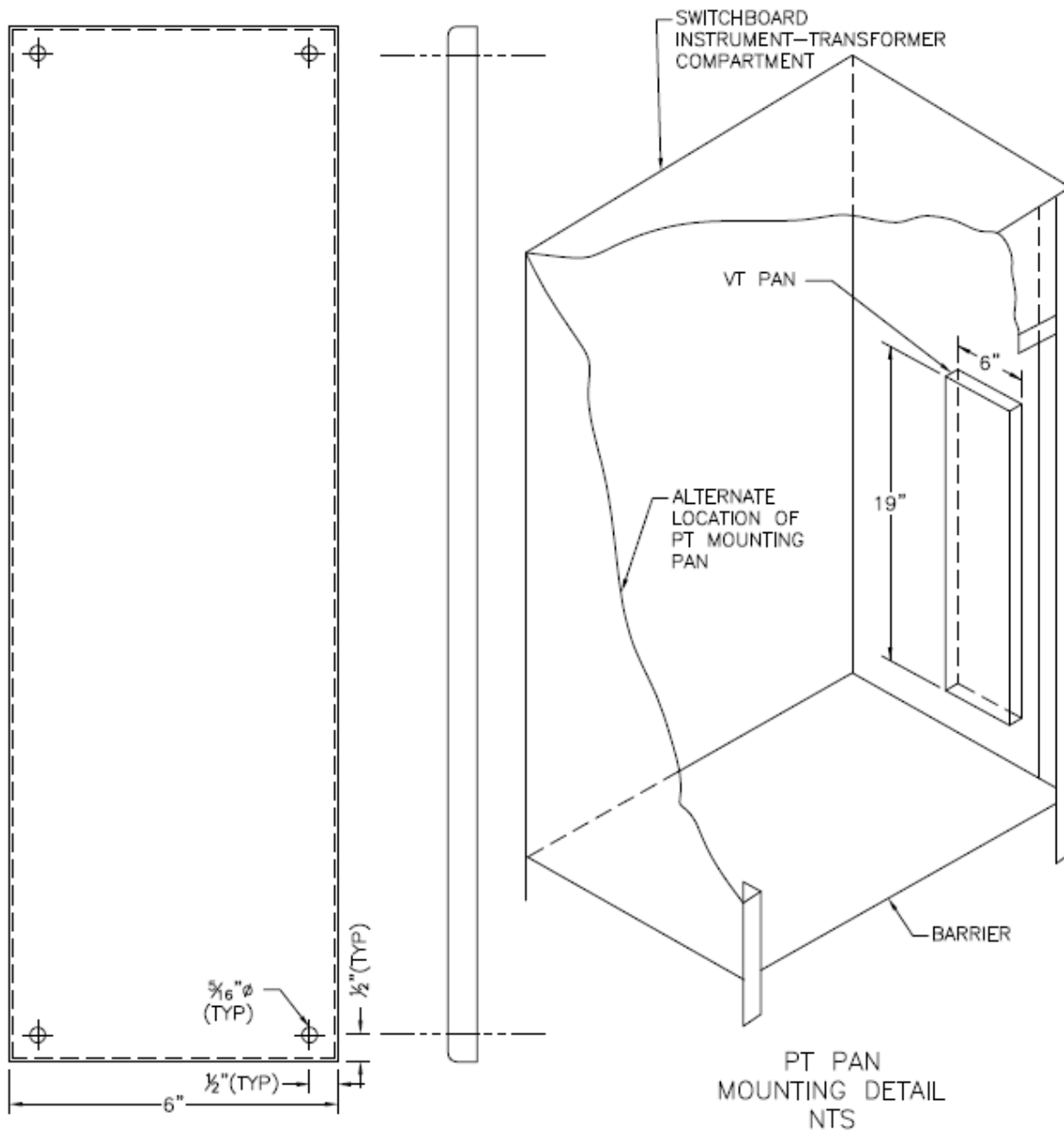

NOTES:

1. FABRICATE FROM 12 GAUGE SHEET METAL. USE STEEL, PER ASTM A36.
2. MOUNT TO SIDE OF CT CABINET WITH 1/4"-20UNC STUDS. EACH MOUNTING STUD SHALL BE LONG ENOUGH TO ALLOW PAN TO BE BOLTED ON WITH ONE NUT AND ONE WASHER.

IREA DRAWING #5

---

## GLOSSARY

**Approved** - Acceptable to the authority having jurisdiction.

**Association** – Intermountain Rural Electric Association

**Backfill** - Native soil or soil brought in from another area, free from sharp objects, rocks, scrap building material, and corrosive material.

**City/Town, County or State Inspector** - The qualified representative of a city/town, county or the State of Colorado, who has been authorized by governmental agencies to inspect electrical service installations on their behalf.

**Clearance** - A set distance between two objects.

**Cold Sequence Metering** – The customer’s circuit breakers are located upstream from the meter. (Turning off the circuit breakers does de-energize the meter.)

**Conduit** - A listed or approved wireway with a smooth interior surface to permit easy drawing-in of the electrical conductors. A conduit may be metallic or nonmetallic, depending on its usage, in accordance with codes and the Association’s Standards.

**Customer** – Any person or company applying for, receiving, using, or agreeing to take electric service or other services supplied by IREA.

**Demand** - The maximum average kilowatt load used by the customer for a specific period of time during the billing period.

**Direct Burial** - The installation of electrical conductors in a trench, without the use of conduit.

**Enclosure** - A sealable cabinet designed for surface or flush mounting, and provided with a frame or trim in which doors or removable covers are hung.

**EUSERC** – Electric Utility Service Equipment Requirements Committee

**Fault Current** – Is the current that flows during a fault condition.

**Hot Sequence Metering** – The customer’s circuit breakers are located downstream from the meter. (Turning off the circuit breakers does not de-energize the meter.)

**Lever Bypass** - A provision for paralleling the meter circuit, allowing the meter to be removed without interrupting service to the customer.

**Meter Loop** - Any provision in which an electrical meter may be installed. Does not include the service disconnect device.

**Meter Pole** - A pole which supports customer owned and maintained metering equipment.

**Meter Base/Socket** - The mounting device consisting of meter jaws, connectors and enclosure for accommodating socket-type meters. The mounting device may be either a single socket or a trough to accommodate more than one mounting unit.

**Metering Equipment** - Any equipment associated with measuring electric energy.

**NEC** - National Electrical Code

**NESC** - National Electrical Safety Code

**Neutral** - The grounded conductor in a single-phase, three-wire or three-phase, four-wire system. The service conductor that is at zero potential to ground.

**Point of Attachment (Point of Service)** - The point at which the Association's service conductors are attached to the customer's premises by an approved insulated clevis.

**Point of Delivery** - The connection point of the meter base, on the customer's premises, where the Association's circuit and the customer's system are interconnected.

**Seal** - The locking device used to secure meter and/or service entrance equipment to assure safety and security for the unit.

**Secondary Voltage** - The lower voltage, after transformation, used to supply the customer with electrical energy. Normally less than 600 V.

**Self-Contained** - In reference to meter sockets: a device designed and rated to continuously carry the entire capacity of the service entrance equipment through the meter.

**Service Entrance Conductors** - Those conductors which extend between the customer's load center and point of delivery.

**Service Entrance Equipment** - Service conduit, conductors, weather head, meter base, enclosures, service disconnect, and load center.

**Service Mast** - The conduit above the meter used to provide mechanical protection for the service conductors and to support the service drop from the Association's system.

**Short Current** - Current flow when there is short circuit in the system and will represent the highest possible fault current that the system can experience.

**Temporary Service** - An electrical service connection installed by the Association to provide power to a customer for a limited time (up to 18 months).

**UL** - (Underwriters Laboratories) A nationally-recognized test laboratory which lists materials it has tested and accepted.

---

***DRAWING LIST***

**GENERAL**

Single-Phase Pad Mounted Equipment Clear Working Space..... 10

Pad Mounted Three-Phase Transformer Clear Working Space ..... 11

Pad Mounted Transformer Location Map and Minimum Clearances..... 12

Minimum Distances for Pad Mounted Transformers ..... 13

Pad Mounted Switchgear with Doors on Both Sides Clear Working Space..... 14

Commercial Multi-Metering EUSERC Cabinet with Clear Working Space ..... 15

Concrete Filled Guard Post Location Requirements..... 16

Post Barrier ..... 17

**TEMPORARY**

Temporary Construction – Overhead Single and Three Phase (200 Amp) ..... 19

Double Breaker Kit / Meter Pedestal 200-400 Amp Service..... 20

Temporary Underground Service at Meter Pedestal, Single-Phase (400 Amp or Less) ..... 21

Temporary Underground Service at Transformer or Secondary Tap Enclosure Single-Phase (400 Amps or Less)..... 22

Temporary Three-Phase CT Meter Installation ..... 23

**RESIDENTIAL**

Meter and Conduit Location Detail ..... 26

Meter on Building Underground Residential Single-Phase Service (400 Amps or Less) ..... 27

Meter Pedestal Underground Residential Single-Phase Service (400 Amps or Less) ..... 28

Single-Phase Overhead Residential (200 to 400 Amps)..... 29

Single-Phase Overhead – Meter Pole Residential (200 to 400 Amps)..... 30

EUSERC Single Meter ..... 31

Meter Wiring Detail .....	33
Multiple Meter Single-Phase Residential (200 Amps or Less per Meter) .....	35
Residential Multi-Meter for EUSERC Applications .....	36
<b><u>COMMERCIAL</u></b>	
Meter on Building Underground Commercial Service (400 Amps or Less).....	42
Meter Pedestal Underground Commercial Single-Phase Service (400 Amps or Less).....	43
Single-Phase Overhead Commercial or Industrial (400 Amps or Less) .....	44
Single-Phase Overhead – Meter Pole Commercial or Industrial (400 Amps or Less).....	45
EUSERC Single Meter .....	46
Multiple Meter Single-Phase Commercial (200 Amps or Less per Meter) .....	47
Commercial Multi-Metering for EUSERC Applications .....	48
Meter Form/Socket/Base Types .....	54
EUSERC cabinet (DWG NO. 354).....	59
102/208 Volt CT EUSERC cabinet (DWG NO. 325) .....	60
277/480 Volt CT/PT EUSERC cabinet (DWG NO. 326).....	61
277/480 Volt CT/PT EUSERC cabinet 0-1000 Amperes (IREA Drawing #3) .....	62
277/480 Volt CT/PT EUSERC cabinet 100-3000 Amperes (IREA Drawing #4).....	64
Potential (Voltage) Transformer Mounting Pan (IREA Drawing #5) .....	66