

Hydrologic Soil Group

Hydrologic Soil Group— Summary by Map Unit — Castle Rock Area, Colorado (CO622)				
Map unit symbol	Map unit name	Rating	Acres in AOI	Percent of AOI
BrD	Bresser sandy loam, cool, 5 to 9 percent slopes	B	11.2	73.8%
Lo	Loamy alluvial land	C	0.5	3.3%
Sa	Sampson loam	B	3.5	22.9%
Totals for Area of Interest			15.2	100.0%

Description

Hydrologic soil groups are based on estimates of runoff potential. Soils are assigned to one of four groups according to the rate of water infiltration when the soils are not protected by vegetation, are thoroughly wet, and receive precipitation from long-duration storms.

The soils in the United States are assigned to four groups (A, B, C, and D) and three dual classes (A/D, B/D, and C/D). The groups are defined as follows:

Group A. Soils having a high infiltration rate (low runoff potential) when thoroughly wet. These consist mainly of deep, well drained to excessively drained sands or gravelly sands. These soils have a high rate of water transmission.

Group B. Soils having a moderate infiltration rate when thoroughly wet. These consist chiefly of moderately deep or deep, moderately well drained or well drained soils that have moderately fine texture to moderately coarse texture. These soils have a moderate rate of water transmission.

Group C. Soils having a slow infiltration rate when thoroughly wet. These consist chiefly of soils having a layer that impedes the downward movement of water or soils of moderately fine texture or fine texture. These soils have a slow rate of water transmission.

Group D. Soils having a very slow infiltration rate (high runoff potential) when thoroughly wet. These consist chiefly of clays that have a high shrink-swell potential, soils that have a high water table, soils that have a claypan or clay layer at or near the surface, and soils that are shallow over nearly impervious material. These soils have a very slow rate of water transmission.

If a soil is assigned to a dual hydrologic group (A/D, B/D, or C/D), the first letter is for drained areas and the second is for undrained areas. Only the soils that in their natural condition are in group D are assigned to dual classes.

Rating Options

Aggregation Method: Dominant Condition

Component Percent Cutoff: None Specified

Tie-break Rule: Higher

APPENDIX B1 - FEMA FIRM PANEL

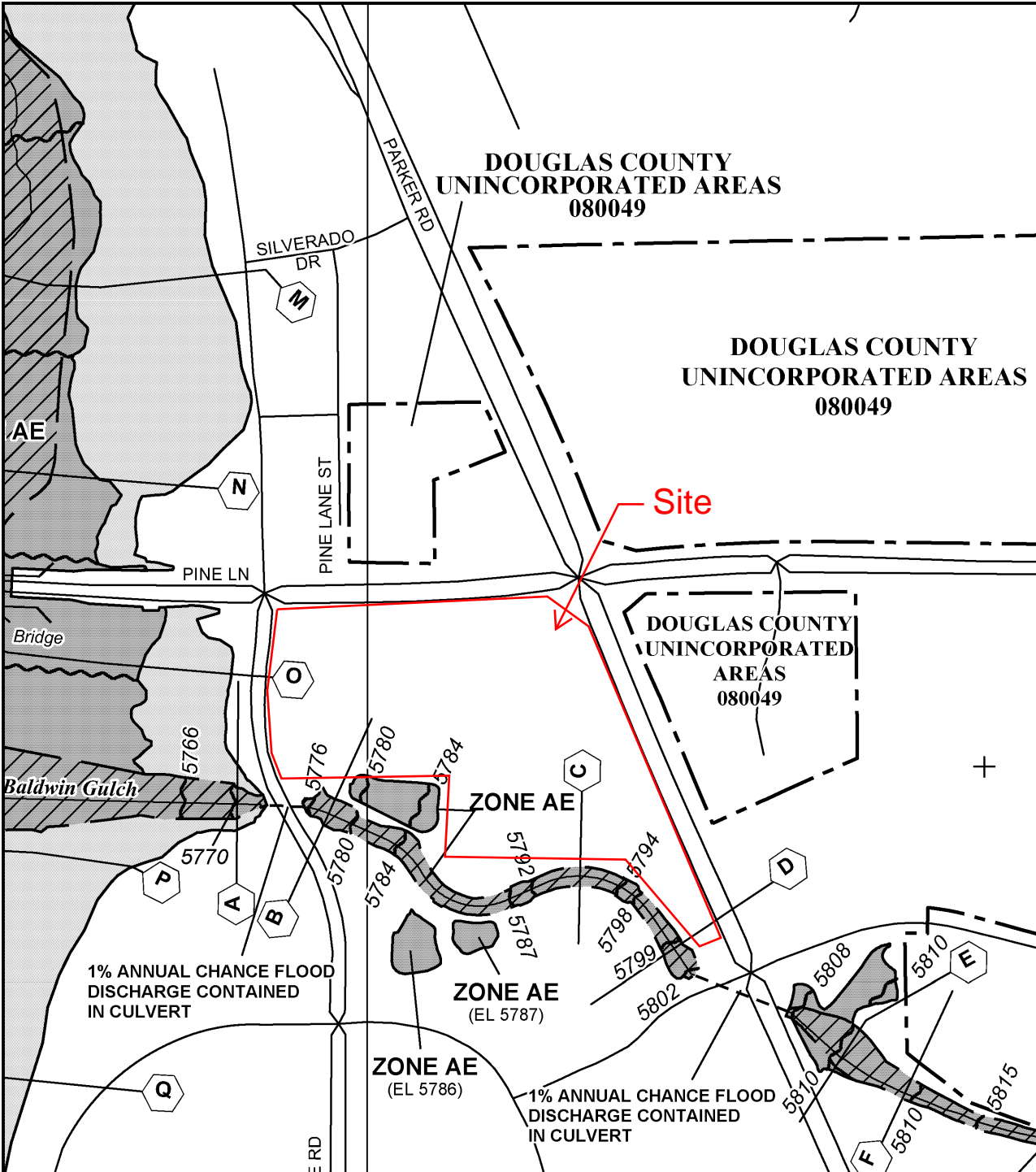

MAP SCALE 1" = 500'

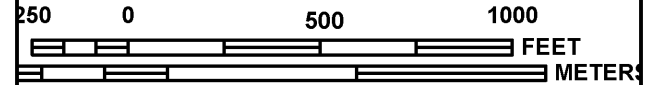

DOUGLAS COUNTY
UNINCORPORATED AREAS
080049

DOUGLAS COUNTY
UNINCORPORATED AREAS
080049

Site

DOUGLAS COUNTY
UNINCORPORATED
AREAS
080049

AE

SILVERADO
DR

PARKER RD

PINE LN

PINE LANE ST

Bridge

Baldwin Gulch

ZONE AE

ZONE AE
(EL 5787)

ZONE AE
(EL 5786)

1% ANNUAL CHANCE FLOOD
DISCHARGE CONTAINED
IN CULVERT

1% ANNUAL CHANCE FLOOD
DISCHARGE CONTAINED
IN CULVERT

PANEL 0067G

FIRM

FLOOD INSURANCE RATE MAP
DOUGLAS COUNTY,
COLORADO
AND INCORPORATED AREAS

PANEL 67 OF 495
(SEE MAP INDEX FOR FIRM PANEL LAYOUT)

CONTAINS:

COMMUNITY	NUMBER	PANEL	SUFFIX
DOUGLAS COUNTY	080049	0067	G
PARKER, TOWN OF	080310	0067	G

Notice to User: The **Map Number** shown below should be used when placing map orders; the **Community Number** shown above should be used on insurance applications for the subject community.



MAP NUMBER
08035C0067G
MAP REVISED
MARCH 16, 2016

Federal Emergency Management Agency

This is an official copy of a portion of the above referenced flood map. It was extracted using F-MIT On-Line. This map does not reflect changes or amendments which may have been made subsequent to the date on the title block. For the latest product information about National Flood Insurance Program flood maps check the FEMA Flood Map Store at www.msc.fema.gov

APPENDIX B2 – RAINFALL DATA

5. HYDROLOGIC CRITERIA

5.1 INTRODUCTION

This section presents the criteria and methodology for determining storm runoff design peaks and volumes to be used in the Town of Parker for preparation of storm drainage plans and facility design. In general, hydrologic analysis of the initial and major storm events for both the historic and fully developed site conditions is required. In addition to the hydrologic analysis for a site, a hydrologic analysis should be performed for all off site basins that impact the proposed site. The Town of Parker adopts procedures prescribed by the Urban Drainage and Flood Control District (UDFCD) for performing hydrologic analysis. These procedures may be found in the Rainfall and Runoff sections of the MANUAL. Standards and technical criteria found in the MANUAL should be followed except where superseded by specific requirements of this manual.

5.2 DESIGN RAINFALL

For any storm runoff technique, design rainfall must first be established. The design rainfall data to be used for the Town of Parker were obtained from NOAA Atlas 2, Precipitation– Frequency Atlas of the Western United States, Volume III– Colorado. The design storm events developed and utilized are the same as those used by UDFCD.

The one-hour point rainfall depths for different frequency events are shown in Table 5.1 herein. Rainfall intensity as a function of the one-hour point rainfall and the time of concentration can be approximated by the following equation which appears in the MANUAL as Equation RA-5.

$$I = (28.5P_1)/(10+t_c)^{0.786}$$

Where, I = rainfall intensity (in/hr)
 P_1 = one-hour point rainfall depth (in)
 t_c = time of concentration (min)

Graphical presentation of the equation is shown as the Time-Intensity-Frequency curves in Figure 5.1 herein. Rainfall intensity for use in the Rational Method may be taken from Figure 5.1 or calculated using the equation.

TABLE 5.1
ONE-HOUR POINT RAINFALL

Frequency of Design Event (yr)	One-hour Point Rainfall, P ₁ (in)
2	0.99
5	1.39
10	1.64
25	1.98
50	2.31
100	2.60

5.3 FLOOD HYDROLOGY OVERVIEW

Various methods exist to determine appropriate flood peaks or hydrographs for storm drainage planning and design. Methods for determining flood peaks or hydrographs are the Rational Method, the Colorado Urban Hydrograph Procedure (CUHP), and Urban Drainage Stormwater Management (UDSWM) model. The Town of Parker discourages the use of computer models other than CUHP and UDSWM since these programs are preferred, if not required, by UDFCD for studies involving major drainageways where UDFCD approval is sought or where maintenance eligibility is requested.

The three methods are briefly described in this section, and a discussion of their applicability to the Town of Parker is discussed. UDSWM is mostly used to combine and route the hydrographs generated using CUHP.

In general, the Rational Method is the most widely used and accepted technique for determining peak flows in urban areas for small basins. Within the constraints outlined in the MANUAL, use of the Rational Method provides a relatively simple but effective way to analyze storm runoff.

CUHP is somewhat more complicated than the Rational Method. It allows a manual computation of a runoff hydrograph which may be used for further hydraulic routing through channels and/or detention ponds. Historically, CUHP is best used in urban areas for which runoff coefficients have been derived. However, recent improvements by UDFCD include consideration for different soil types, thus CUHP is now more applicable to rural areas. The reader is referred to UDFCD for the latest version of CUHP.

UDSWM is a computer model that generates runoff hydrographs and routes and combines these hydrographs. UDSWM is a modified version of the Runoff Block of the Environmental Protection Agency's Storm Water Management Model (SWMM). It has been modified to be used in conjunction with CUHP. Table 5.2 herein provides guidance on selecting the appropriate method for a given project.

APPENDIX B3 - C-VALUES

Table 6-5. Runoff coefficients, *c*

Total or Effective % Impervious	NRCS Hydrologic Soil Group A						
	2-Year	5-Year	10-Year	25-Year	50-Year	100-Year	500-Year
2%	0.01	0.01	0.01	0.01	0.04	0.13	0.27
5%	0.02	0.02	0.02	0.03	0.07	0.15	0.29
10%	0.04	0.05	0.05	0.07	0.11	0.19	0.32
15%	0.07	0.08	0.08	0.1	0.15	0.23	0.35
20%	0.1	0.11	0.12	0.14	0.2	0.27	0.38
25%	0.14	0.15	0.16	0.19	0.24	0.3	0.42
30%	0.18	0.19	0.2	0.23	0.28	0.34	0.45
35%	0.21	0.23	0.24	0.27	0.32	0.38	0.48
40%	0.25	0.27	0.28	0.32	0.37	0.42	0.51
45%	0.3	0.31	0.33	0.36	0.41	0.46	0.54
50%	0.34	0.36	0.37	0.41	0.45	0.5	0.58
55%	0.39	0.4	0.42	0.45	0.49	0.54	0.61
60%	0.43	0.45	0.47	0.5	0.54	0.58	0.64
65%	0.48	0.5	0.51	0.54	0.58	0.62	0.67
70%	0.53	0.55	0.56	0.59	0.62	0.65	0.71
75%	0.58	0.6	0.61	0.64	0.66	0.69	0.74
80%	0.63	0.65	0.66	0.69	0.71	0.73	0.77
85%	0.68	0.7	0.71	0.74	0.75	0.77	0.8
90%	0.73	0.75	0.77	0.79	0.79	0.81	0.84
95%	0.79	0.81	0.82	0.83	0.84	0.85	0.87
100%	0.84	0.86	0.87	0.88	0.88	0.89	0.9
Total or Effective % Impervious	NRCS Hydrologic Soil Group B						
	2-Year	5-Year	10-Year	25-Year	50-Year	100-Year	500-Year
2%	0.01	0.01	0.07	0.26	0.34	0.44	0.54
5%	0.03	0.03	0.1	0.28	0.36	0.45	0.55
10%	0.06	0.07	0.14	0.31	0.38	0.47	0.57
15%	0.09	0.11	0.18	0.34	0.41	0.5	0.59
20%	0.13	0.15	0.22	0.38	0.44	0.52	0.61
25%	0.17	0.19	0.26	0.41	0.47	0.54	0.63
30%	0.2	0.23	0.3	0.44	0.49	0.57	0.65
35%	0.24	0.27	0.34	0.47	0.52	0.59	0.66
40%	0.29	0.32	0.38	0.5	0.55	0.61	0.68
45%	0.33	0.36	0.42	0.53	0.58	0.64	0.7
50%	0.37	0.4	0.46	0.56	0.61	0.66	0.72
55%	0.42	0.45	0.5	0.6	0.63	0.68	0.74
60%	0.46	0.49	0.54	0.63	0.66	0.71	0.76
65%	0.5	0.54	0.58	0.66	0.69	0.73	0.77
70%	0.55	0.58	0.62	0.69	0.72	0.75	0.79
75%	0.6	0.63	0.66	0.72	0.75	0.78	0.81
80%	0.64	0.67	0.7	0.75	0.77	0.8	0.83
85%	0.69	0.72	0.74	0.78	0.8	0.82	0.85
90%	0.74	0.76	0.78	0.81	0.83	0.84	0.87
95%	0.79	0.81	0.82	0.85	0.86	0.87	0.88
100%	0.84	0.86	0.86	0.88	0.89	0.89	0.9

APPENDIX C - OVERALL DRAINAGE MAP

C:\Users\Jack.Kasprzak\Desktop\Parker & Pine Mixed Use\CADD\PlanSheets\096502001ST_DET.dwg Kasprzak, Jack 10/8/2019 10:57 AM
 THIS DOCUMENT IS THE PROPERTY OF KIMLEY-HORN AND ASSOCIATES, INC. AND IS TO BE USED ONLY FOR THE PROJECT AND SITE SPECIFIC PURPOSES. IT IS NOT TO BE REPRODUCED, COPIED, OR TRANSMITTED IN ANY FORM OR BY ANY MEANS, ELECTRONIC OR MECHANICAL, WITHOUT THE WRITTEN PERMISSION OF KIMLEY-HORN AND ASSOCIATES, INC.

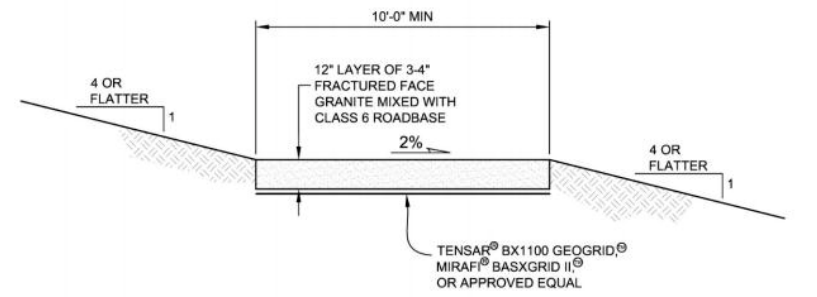
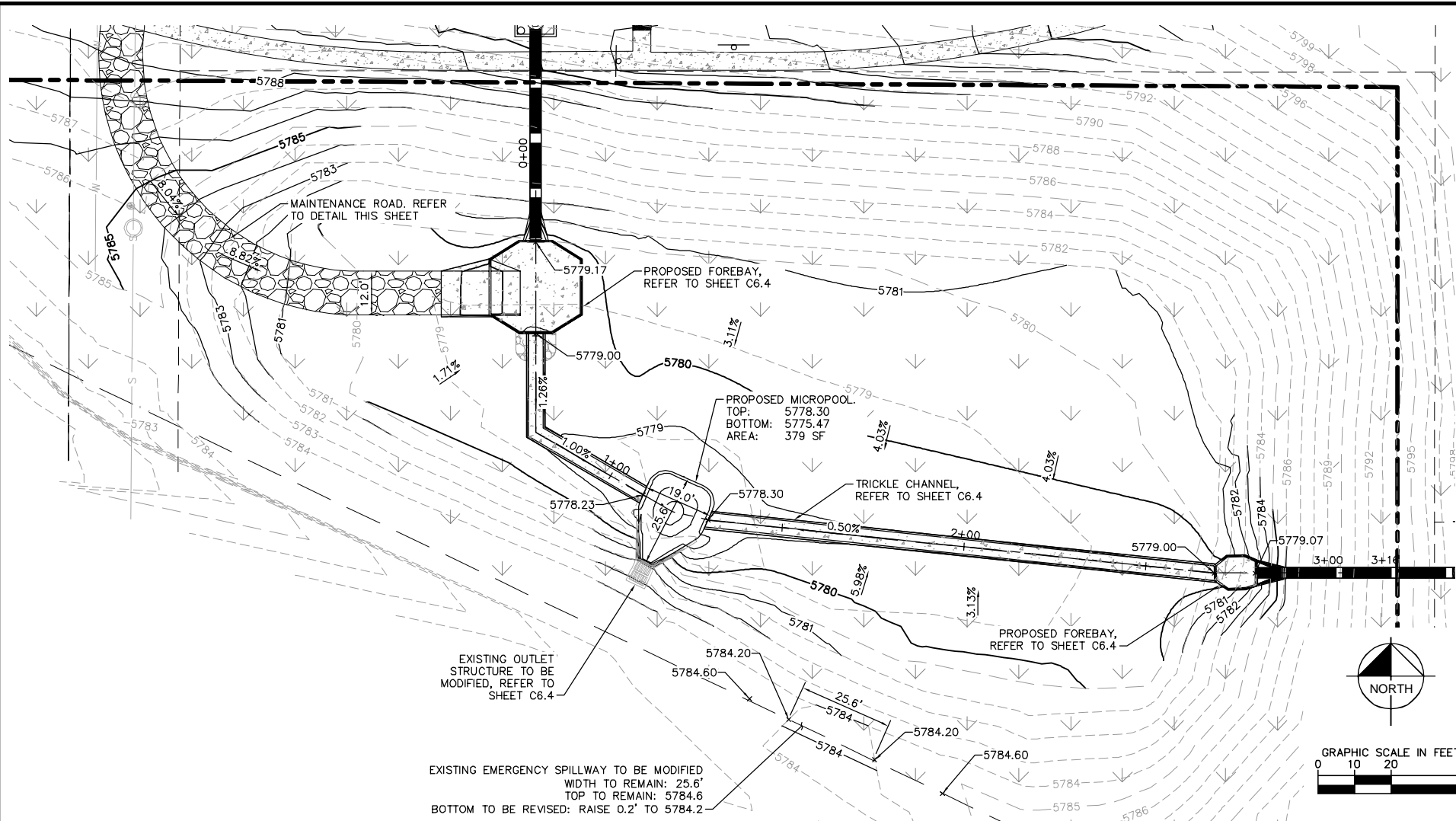

CROSS SECTION BELOW EURV WATER SURFACE

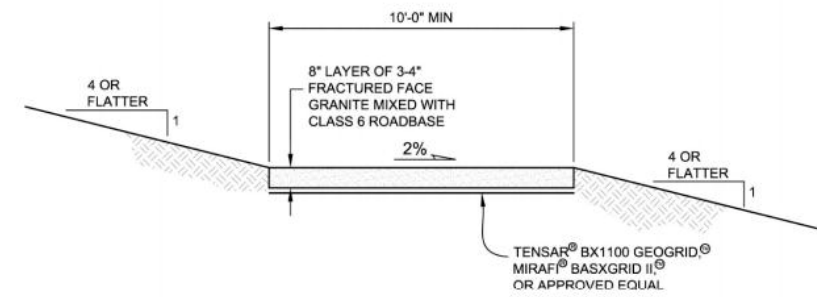

CROSS SECTION ABOVE EURV WATER SURFACE

MAINTENANCE ROAD DETAILS N.T.S.

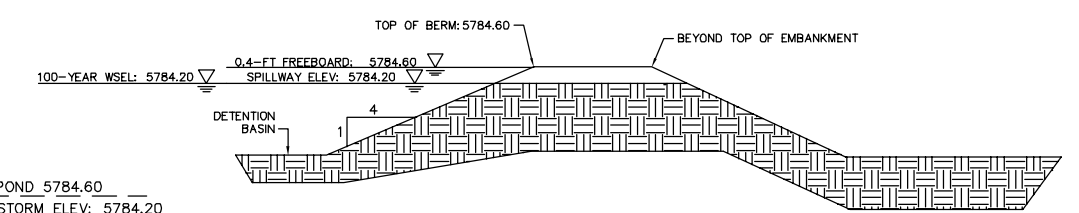

MODIFIED EXISTING EMERGENCY SPILLWAY DETAIL N.T.S.

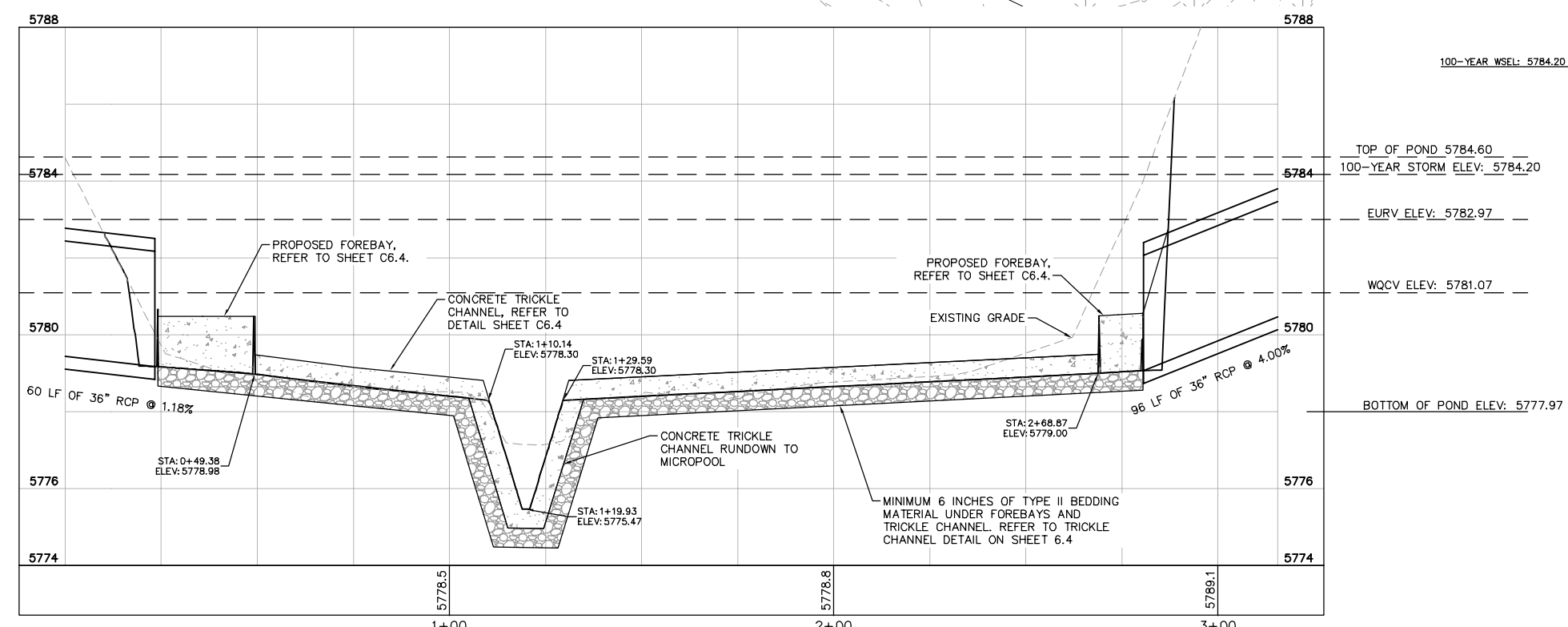

POND PROFILE
 HORIZONTAL SCALE: 1" = 20'
 VERTICAL SCALE: 1" = 2'

NO.	REVISION	BY	DATE	APPR.

Kimley»Horn
 2020 KIMLEY-HORN AND ASSOCIATES, INC.
 4582 South Ulster Street, Suite 1500
 Denver, Colorado 80237 (303) 228-2300

DESIGNED BY: DLS
 DRAWN BY: JRK
 CHECKED BY: DLS
 DATE: 04/24/20

PARKER AND PINE FILING 1
 PARKER, CO
 CONSTRUCTION DOCUMENTS
 POND PLANS AND PROFILE

PRELIMINARY
 FOR REVIEW ONLY
 NOT FOR
 CONSTRUCTION
Kimley»Horn
 Kimley-Horn and Associates, Inc.

PROJECT NO.
 096502001
 DRAWING NAME
 096502001ST_DET
 C6.3



C:\Users\Jack.Kasprzak\Desktop\Parker & Pine Mixed Use\CADD\PlanSheets\096502001ST_DET.dwg Kasprzak, Jack 10/8/2019 10:57 AM
 PRELIMINARY. FOR REVIEW ONLY. NOT FOR CONSTRUCTION. THIS DOCUMENT IS THE PROPERTY OF KIMLEY-HORN AND ASSOCIATES, INC. AND SHALL BE WITHOUT LIABILITY TO KIMLEY-HORN AND ASSOCIATES, INC. IF REPRODUCED OR TRANSMITTED IN ANY FORM OR BY ANY MEANS, WITHOUT THE WRITTEN AUTHORIZATION AND SIGNATURE OF KIMLEY-HORN AND ASSOCIATES, INC. AND WITHOUT THE CONSENT OF THE ORIGINAL AUTHOR. ANY REVISIONS TO THIS DOCUMENT SHALL BE INDICATED BY A REVISION TABLE AND SHALL BE MADE IN ACCORDANCE WITH THE REVISIONS TO THIS DOCUMENT.

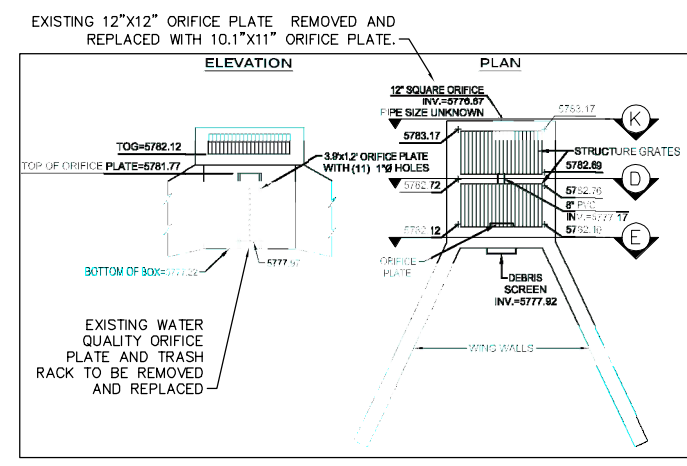

J EXISTING OUTLET STRUCTURE
SCALE: 1" = 5'

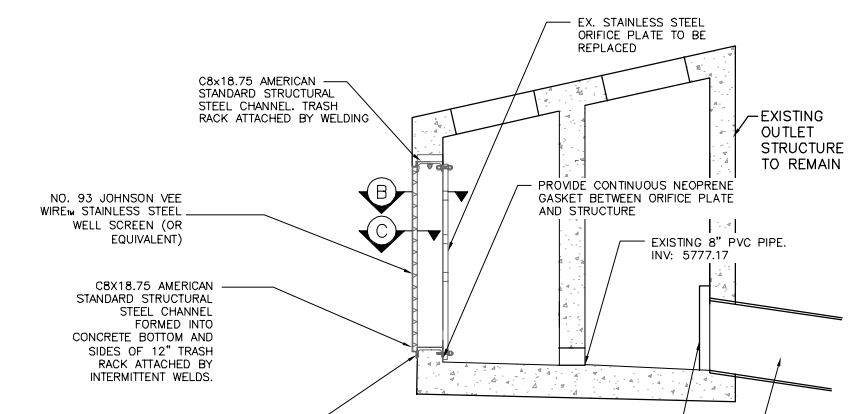

A SECTION A
NTS

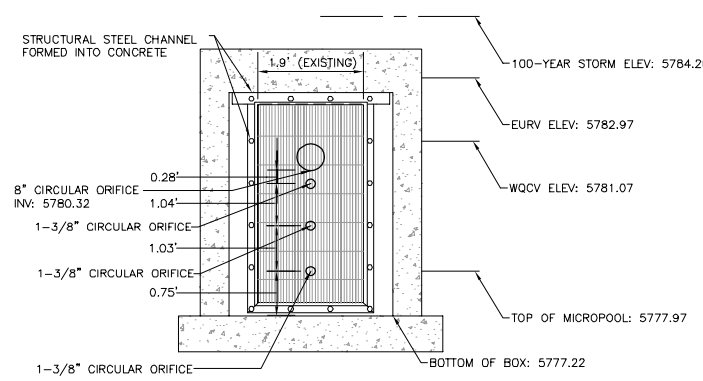

E ORIFICE PLATE AND TRASH RACK DETAIL
N.T.S.

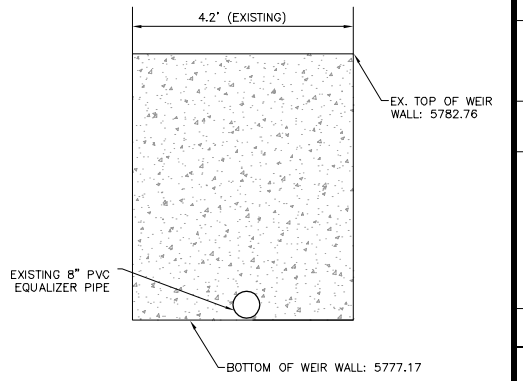

D EXISTING INTERNAL WEIR
N.T.S.

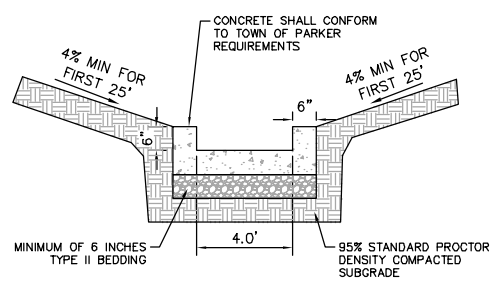

G TRICKLE CHANNEL
N.T.S.

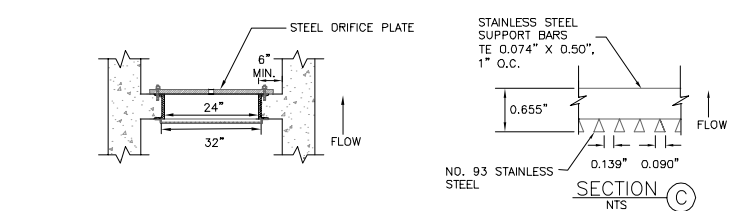

F EXISTING OUTLET STRUCTURE WITH MODIFIED ORIFICE PLATE
N.T.S.

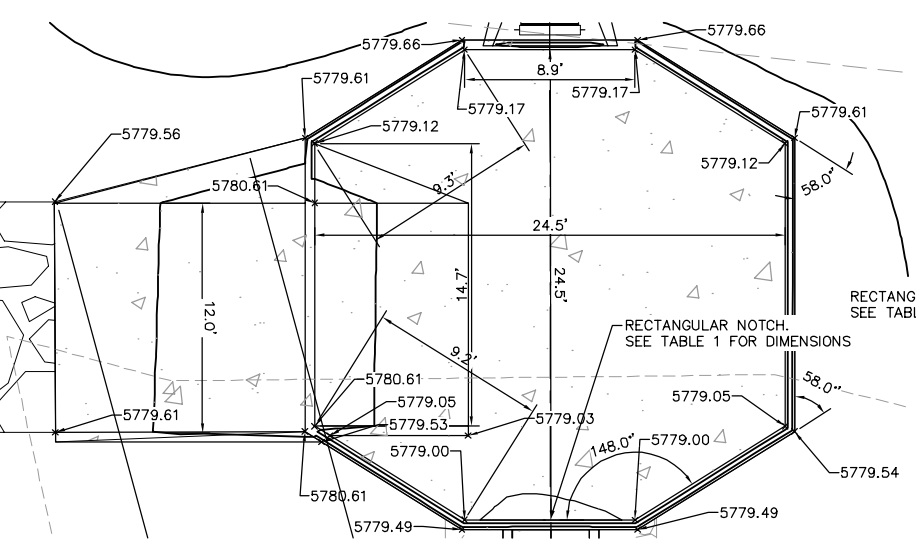

H FOREBAY WEST
1" = 5'

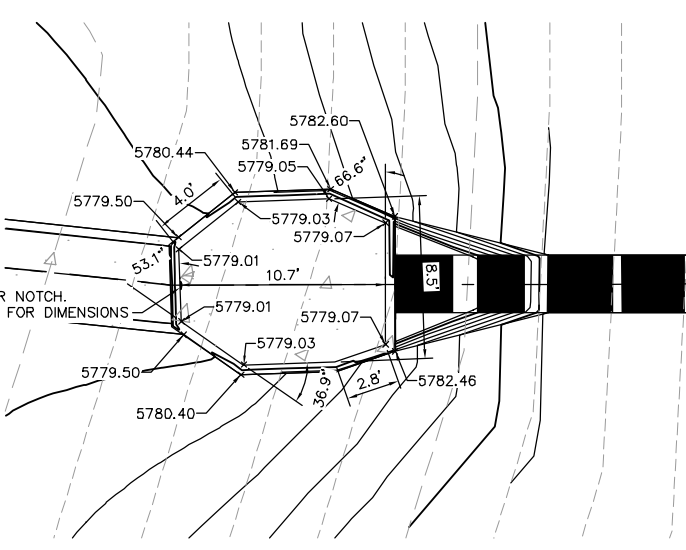

I FOREBAY EAST
1" = 5'

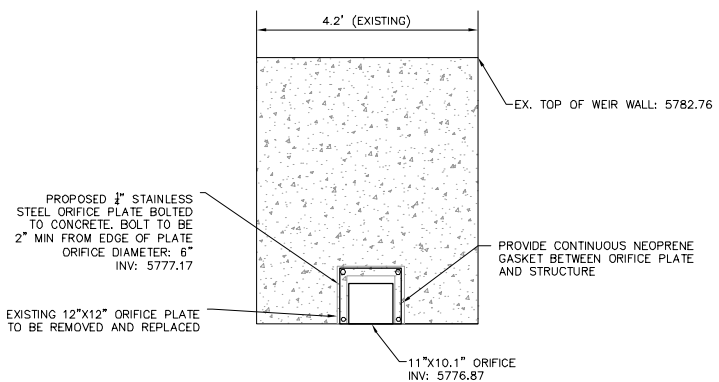

K MODIFIED ORIFICE PLATE
N.T.S.

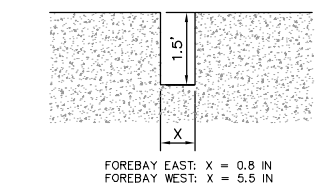

L FOREBAY NOTCH DETAIL
N.T.S.

Forebay ID	Watershed Area (AC)	WQCV (CF)	Required Volume (CF)	Forebay Size (SF)	Required Height (Inches)	Provided Height (Inches)	Q ₁₀₀ (cfs)	Required Release Rate (cfs)	Required Notch Width (Inches)	Actual Notch Width (Inches)	Actual Release Rate (cfs)
West	13.94	14,295	286	523	6.6	18.0	119.14	2.38	5.5	5.5	2.53
East	2.22	2,277	46	80	6.8	18.0	16.06	0.32	0.75	0.8	0.36

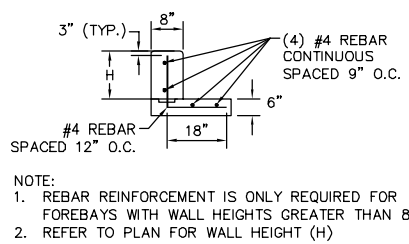

N FOREBAY WALL SECTION TYPICAL DETAIL
NTS

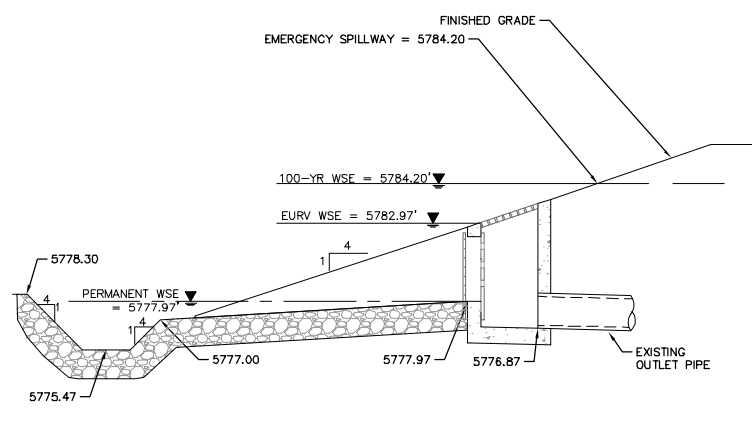

M MICROPOL
N.T.S.

NO.	REVISION	BY	DATE	APPR.

Kimley»Horn
 2020 KIMLEY-HORN AND ASSOCIATES, INC.
 4582 South Ulster Street, Suite 1500
 Denver, Colorado 80237 (303) 228-2300

DESIGNED BY: DLS
 DRAWN BY: JRK
 CHECKED BY: DLS
 DATE: 04/24/20

PARKER AND PINE FILING 1
 PARKER, CO
 CONSTRUCTION DOCUMENTS
 POND DETAILS

PRELIMINARY
 FOR REVIEW ONLY
 NOT FOR CONSTRUCTION
Kimley»Horn
 Kimley-Horn and Associates, Inc.

PROJECT NO.
 096502001

DRAWING NAME
 096502001ST_DET

C6.4



APPENDIX D - RATIONAL METHOD CALCULATIONS, INLET CALCULATIONS

Rainfall Intensity

IDF - Intensity, Duration, Frequency Data

Time Intensity Frequency Tabulation

TIME	2 YR	5 YR	10 YR	100 YR
5	3.36	4.71	5.56	8.82
6	3.19	4.48	5.29	8.38
7	3.04	4.27	5.04	7.99
8	2.91	4.09	4.82	7.64
9	2.79	3.92	4.62	7.32
10	2.68	3.76	4.44	7.03
11	2.58	3.62	4.27	6.77
12	2.49	3.49	4.12	6.53
13	2.40	3.37	3.98	6.30
14	2.32	3.26	3.84	6.09
15	2.25	3.16	3.72	5.90
16	2.18	3.06	3.61	5.72
17	2.12	2.97	3.50	5.56
18	2.06	2.89	3.41	5.40
19	2.00	2.81	3.31	5.25
20	1.95	2.73	3.23	5.11
21	1.90	2.66	3.14	4.98
22	1.85	2.60	3.07	4.86
23	1.81	2.54	2.99	4.75
24	1.76	2.48	2.92	4.64
25	1.73	2.42	2.86	4.53
26	1.69	2.37	2.80	4.43
27	1.65	2.32	2.74	4.34
28	1.62	2.27	2.68	4.25
29	1.58	2.22	2.62	4.16
30	1.55	2.18	2.57	4.08
31	1.52	2.14	2.52	4.00
32	1.49	2.10	2.48	3.93
33	1.47	2.06	2.43	3.85
34	1.44	2.02	2.39	3.78
35	1.42	1.99	2.35	3.72
36	1.39	1.95	2.31	3.66
37	1.37	1.92	2.27	3.59
38	1.35	1.89	2.23	3.53
39	1.32	1.86	2.19	3.48
40	1.30	1.83	2.16	3.42
41	1.28	1.80	2.13	3.37
42	1.26	1.77	2.09	3.32
43	1.25	1.75	2.06	3.27
44	1.23	1.72	2.03	3.22
45	1.21	1.70	2.00	3.18
46	1.19	1.67	1.98	3.13
47	1.18	1.65	1.95	3.09
48	1.16	1.63	1.92	3.05
49	1.14	1.61	1.90	3.01
50	1.13	1.59	1.87	2.97
51	1.11	1.57	1.85	2.93
52	1.10	1.55	1.82	2.89
53	1.09	1.53	1.80	2.85
54	1.07	1.51	1.78	2.82
55	1.06	1.49	1.76	2.79
56	1.05	1.47	1.74	2.75
57	1.04	1.45	1.72	2.72
58	1.02	1.44	1.70	2.69
59	1.01	1.42	1.68	2.66
60	1.00	1.40	1.66	2.63

Note:
Intensity values utilized as published within the Town of Parker
Storm Drainage Criteria Manual, Table 5.1

Time Intensity Frequency Tabulation

TIME	2 YR	5 YR	10 YR	100 YR
5	3.36	4.71	5.56	8.82
6	3.19	4.48	5.29	8.38
7	3.04	4.27	5.04	7.99
8	2.91	4.09	4.82	7.64
9	2.79	3.92	4.62	7.32
10	2.68	3.76	4.44	7.03
11	2.58	3.62	4.27	6.77
12	2.49	3.49	4.12	6.53
13	2.40	3.37	3.98	6.30
14	2.32	3.26	3.84	6.09
15	2.25	3.16	3.72	5.90
16	2.18	3.06	3.61	5.72
17	2.12	2.97	3.50	5.56
18	2.06	2.89	3.41	5.40
19	2.00	2.81	3.31	5.25
20	1.95	2.73	3.23	5.11
21	1.90	2.66	3.14	4.98
22	1.85	2.60	3.07	4.86
23	1.81	2.54	2.99	4.75
24	1.76	2.48	2.92	4.64
25	1.73	2.42	2.86	4.53
26	1.69	2.37	2.80	4.43
27	1.65	2.32	2.74	4.34
28	1.62	2.27	2.68	4.25
29	1.58	2.22	2.62	4.16
30	1.55	2.18	2.57	4.08
31	1.52	2.14	2.52	4.00
32	1.49	2.10	2.48	3.93
33	1.47	2.06	2.43	3.85
34	1.44	2.02	2.39	3.78
35	1.42	1.99	2.35	3.72
36	1.39	1.95	2.31	3.66
37	1.37	1.92	2.27	3.59
38	1.35	1.89	2.23	3.53
39	1.32	1.86	2.19	3.48
40	1.30	1.83	2.16	3.42
41	1.28	1.80	2.13	3.37
42	1.26	1.77	2.09	3.32
43	1.25	1.75	2.06	3.27
44	1.23	1.72	2.03	3.22
45	1.21	1.70	2.00	3.18
46	1.19	1.67	1.98	3.13
47	1.18	1.65	1.95	3.09
48	1.16	1.63	1.92	3.05
49	1.14	1.61	1.90	3.01
50	1.13	1.59	1.87	2.97
51	1.11	1.57	1.85	2.93
52	1.10	1.55	1.82	2.89
53	1.09	1.53	1.80	2.85
54	1.07	1.51	1.78	2.82
55	1.06	1.49	1.76	2.79
56	1.05	1.47	1.74	2.75
57	1.04	1.45	1.72	2.72
58	1.02	1.44	1.70	2.69
59	1.01	1.42	1.68	2.66
60	1.00	1.40	1.66	2.63

BASIN IMPERVIOUSNESS AND RUNOFF COEFFICIENT

Landuse	I	C ₂	C ₅	C ₁₀	C ₁₀₀
Landscape	2%	0.01	0.01	0.07	0.44
Roof	90%	0.74	0.76	0.78	0.84
Streets/Drives and Walks	100%	0.84	0.86	0.86	0.89

All Basins

Basin Designation	A _{TOTAL} (AC)	A _{TOTAL} (SF)	A _{LANDSCAPE} (SF)	A _{ROOF} (SF)	A _{STREETS/DRIVES & WALKS} (SF)	I _{WEIGHTED}	C ₂	C ₅	C ₁₀₀	SIGN POI	INLET
1.1	1.43	62,381	9,500	0	52,881	85%	0.71	0.73	0.82		
1.2	1.97	85,635	13,000	0	72,635	85%	0.71	0.73	0.82		
2.0	0.88	38,143	6,000	0	32,143	85%	0.71	0.73	0.82		
3.0	1.97	85,881	13,000	0	72,881	85%	0.71	0.73	0.82		
4.1	1.14	49,452	7,500	0	41,952	85%	0.71	0.73	0.82		
4.2	0.77	33,396	5,000	0	28,396	85%	0.72	0.73	0.82		
5.0	1.13	49,201	7,500	0	41,701	85%	0.71	0.73	0.82		
6.0	2.22	96,743	15,000	0	81,743	85%	0.71	0.73	0.82		
7.0	1.02	44,356	7,000	0	37,356	85%	0.71	0.73	0.82		
8.0	1.94	84,345	13,000	0	71,345	85%	0.71	0.73	0.82		
9.0	0.10	4,470	0	0	4,470	100%	0.84	0.86	0.89		
10.0	0.16	6,975	0	0	6,975	100%	0.84	0.86	0.89		
11.0	0.21	9,219	0	0	9,219	100%	0.84	0.86	0.89		
12.0	0.14	6,073	0	0	6,073	100%	0.84	0.86	0.89		
13.0	0.08	3,465	0	0	3,465	100%	0.84	0.86	0.89		
14.0	0.17	7,207	0	0	7,207	100%	0.84	0.86	0.89		
15.0	0.18	7,746	0	0	7,746	100%	0.84	0.86	0.89		
16.0	0.17	7,231	0	0	7,231	100%	0.84	0.86	0.89		
17.0	0.11	4,854	0	0	4,854	100%	0.84	0.86	0.89		
18.0	0.39	17,130	0	0	17,130	100%	0.84	0.86	0.89		
19.0	0.11	4,871	0	0	4,871	100%	0.84	0.86	0.89		
20.0	0.03	1,228	0	0	1,228	100%	0.84	0.86	0.89		
	16.30	710,001	96,500	-	613,501	87%	0.73	0.74	0.83		

Detained Basins

Basin Designation	A _{TOTAL} (AC)	A _{TOTAL} (SF)	A _{LANDSCAPE} (SF)	A _{ROOF} (SF)	A _{DRIVES & WALKS} (SF)	I _{WEIGHTED}	C ₂	C ₅	C ₁₀₀
1	1.43	62,381	9,500	0	52,881	85%	0.71	0.73	0.82
2	1.97	85,635	13,000	0	72,635	85%	0.71	0.73	0.82
3	0.88	38,143	6,000	0	32,143	85%	0.71	0.73	0.82
4	1.97	85,881	13,000	0	72,881	85%	0.71	0.73	0.82
5	1.14	49,452	7,500	0	41,952	85%	0.71	0.73	0.82
6	0.77	33,396	5,000	0	28,396	85%	0.72	0.73	0.82
7	1.13	49,201	7,500	0	41,701	85%	0.71	0.73	0.82
8	2.22	96,743	15,000	0	81,743	85%	0.71	0.73	0.82
9	1.02	44,356	7,000	0	37,356	85%	0.71	0.73	0.82
10	1.94	84,345	13,000	0	71,345	85%	0.71	0.73	0.82
11	0.10	4,470	0	0	4,470	100%	0.84	0.86	0.89
12	0.16	6,975	0	0	6,975	100%	0.84	0.86	0.89
13	0.21	9,219	0	0	9,219	100%	0.84	0.86	0.89
14	0.14	6,073	0	0	6,073	100%	0.84	0.86	0.89
15	0.08	3,465	0	0	3,465	100%	0.84	0.86	0.89
16	0.17	7,207	0	0	7,207	100%	0.84	0.86	0.89
17	0.18	7,746	0	0	7,746	100%	0.84	0.86	0.89
18	0.39	17,130	0	0	17,130	100%	0.84	0.86	0.89
	15.88	691,818	96,500	-	595,318	86%	0.72	0.74	0.83

Undetained Basins

Basin Designation	A _{TOTAL} (AC)	A _{TOTAL} (SF)	A _{LANDSCAPE} (SF)	A _{ROOF} (SF)	A _{DRIVES & WALKS} (SF)	I _{WEIGHTED}	C ₂	C ₅	C ₁₀₀
19	0.11	4,871	0	0	4,871	100%	0.84	0.86	0.89
20	0.03	1,228	0	0	1,228	100%	0.84	0.86	0.89
	0.14	6,099	-	-	6,099	100%	0.84	0.86	0.89

Time of Concentration

DESIGN POINT	SUB-BASIN DATA						INITIAL / OVERLAND TIME T(i)			TRAVEL TIME T(t)					T(c) CHECK (URBANIZED BASINS)			FINAL T(c) (MIN)
	DRAIN BASIN	AREA SF	AREA AC	NRCS Soil Type	I %	C(5)	Length FT	Slope %	T(i) MIN	Length FT	Slope %	Coefficient	Velocity FPS	T(t) MIN	T(c) (MIN)	TOTAL LENGTH	L/180+10	
1.1	1.1	62,381	1.43	B	85%	0.73	45	2.0%	3.6	-	-	20	0.0	0.0	5.0	45	10.3	5.0
1.2	1.2	85,635	1.97	B	85%	0.73	41	21.0%	1.6	450	3.1%	15	2.6	2.8	5.0	491	12.7	5.0
2.0	2.0	38,143	0.88	B	85%	0.73	40	5.6%	2.4	60	3.3%	20	3.6	0.3	5.0	100	10.6	5.0
3.0	3.0	85,881	1.97	B	85%	0.73	69	4.3%	3.5	97	1.3%	20	2.2	0.7	5.0	166	10.9	5.0
4.1	4.1	49,452	1.14	B	85%	0.73	170	7.0%	4.6	50	2.7%	20	3.3	0.3	5.0	220	11.2	5.0
4.2	4.2	33,396	0.77	B	85%	0.73	93	9.2%	3.1	163	3.7%	20	3.8	0.7	5.0	256	11.4	5.0
5.0	5.0	49,201	1.13	B	85%	0.73	0	0.0%		230	1.0%	21	2.1	1.8	5.0	230	11.3	5.0
6.0	6.0	96,743	2.22	B	85%	0.73	50	2.0%	3.8	150	3.0%	20	3.5	0.7	5.0	200	11.1	5.0
7.0	7.0	44,356	1.02	B	85%	0.73	35	1.5%	3.5	105	2.0%	20	2.8	0.6	5.0	140	10.8	5.0
8.0	8.0	84,345	1.94	B	85%	0.73	100	1.0%	6.8	10	15.0%	20	7.7	0.0	6.8	110	10.6	6.8
9.0	9.0	4,470	0.10	B	100%	0.86	101	101.0%	0.9	11	115.0%	21	22.5	0.0	5.0	112	10.6	5.0
10.0	10.0	6,975	0.16	B	100%	0.86	75	5.0%	2.2	130	2.5%	20	3.2	0.7	5.0	205	11.1	5.0
11.0	11.0	9,219	0.21	B	100%	0.86	45	4.3%	1.8	500	3.6%	20	3.8	2.2	5.0	545	13.0	5.0
12.0	12.0	6,073	0.14	B	100%	0.86	100	1.0%	4.4	10	15.0%	20	7.7	0.0	5.0	110	10.6	5.0
13.0	13.0	3,465	0.08	B	100%	0.86	101	101.0%	0.9	11	115.0%	21	22.5	0.0	5.0	112	10.6	5.0
14.0	14.0	7,207	0.17	B	100%	0.86	63	2.0%	2.8	98	0.7%	20	1.7	1.0	5.0	161	10.9	5.0
15.0	15.0	7,746	0.18	B	100%	0.86	35	17.0%	1.0	72	1.2%	20	2.2	0.5	5.0	107	10.6	5.0
16.0	16.0	7,231	0.17	B	100%	0.86	90	15.0%	1.7	50	3.0%	20	3.5	0.2	5.0	140	10.8	5.0
17.0	17.0	4,854	0.11	B	100%	0.86	90	15.0%	1.7	51	3.0%	20	3.5	0.2	5.0	141	10.8	5.0
18.0	18.0	17,130	0.39	B	100%	0.86	90	15.0%	1.7	52	3.0%	20	3.5	0.3	5.0	142	10.8	5.0
19.0	19.0	4,871	0.11	B	100%	0.86	90	15.0%	1.7	53	3.0%	20	3.5	0.3	5.0	143	10.8	5.0
20.0	20.0	1,228	0.03	B	100%	0.86	90	15.0%	1.7	54	3.0%	20	3.5	0.3	5.0	144	10.8	5.0

Watercourse Coefficient

Forest & Meadow	2.5
Fallow or Cultivation	5.0
Short Grass Pasture & Lawns	7.0
Nearly Bare Ground	10.0
Grassed Waterway	15.0
Paved Area and Shallow Gutter	20.0

CIA Runoff Calculations

2-Year Design Storm Runoff Calculations

(Rational Method Procedure)

BASIN INFORMATION				DIRECT RUNOFF				TOTAL RUNOFF				REMARKS
DESIGN POINT	DRAIN BASIN	AREA Ac	RUNOFF COEFF	T(c) Min	C x A	I In/Hr	Q CFS	T(c) Min	SUM C x A	I In/Hr	Q CFS	
1	1.1	1.43	0.71	5.0	1.02	3.36	3.43	5.0	1.02	3.4	3.43	
1	1.2	1.97	0.71	5.0	1.40	3.36	4.71	5.0	2.4	3.4	8.14	
1	2.0	0.88	0.71	5.0	0.62	3.36	2.09	5.0	3.0	3.4	10.23	
1	3.0	1.97	0.71	5.0	1.41	3.36	4.73	5.0	4.5	3.4	14.96	
1	4.1	1.14	0.71	5.0	0.81	3.36	2.72	5.0	5.3	3.4	17.68	
1	4.2	0.77	0.72	5.0	0.549	3.36	1.84	5.0	5.8	3.4	19.53	
1	5.0	1.13	0.71	5.0	0.806	3.36	2.71	5.0	6.6	3.4	22.23	
1	6.0	2.22	0.71	5.0	1.580	3.36	5.30	5.0	8.2	3.4	27.54	
1	7.0	1.02	0.71	5.0	0.722	3.36	2.42	5.0	8.9	3.4	29.96	
1	8.0	1.94	0.71	6.8	1.379	3.09	4.26	5.0	10.3	3.4	34.59	
1	9.0	0.10	0.84	5.0	0.086	3.36	0.29	5.0	10.4	3.4	34.88	
1	10.0	0.16	0.84	5.0	0.135	3.36	0.45	5.0	10.5	3.4	35.33	
1	11.0	0.21	0.84	5.0	0.178	3.36	0.60	5.0	10.7	3.4	35.93	
1	12.0	0.14	0.84	5.0	0.117	3.36	0.39	5.0	10.8	3.4	36.32	
1	13.0	0.08	0.84	5.0	0.067	3.36	0.22	5.0	10.9	3.4	36.55	
1	14.0	0.17	0.84	5.0	0.139	3.36	0.47	5.0	11.0	3.4	37.01	
1	15.0	0.18	0.84	5.0	0.149	3.36	0.50	5.0	11.2	3.4	37.51	
1	16.0	0.17	0.84	5.0	0.139	3.36	0.47	5.0	11.3	3.4	37.98	
1	17.0	0.11	0.84	5.0	0.094	3.36	0.31	5.0	11.4	3.4	38.30	
1	18.0	0.39	0.84	5.0	0.330	3.36	1.11	5.0	11.7	3.4	39.41	
1	19.0	0.11	0.84	5.0	0.094	3.36	0.32	5.0	11.8	3.4	39.72	
1	20.0	0.03	0.84	5.0	0.024	3.36	0.08	5.0	11.9	3.4	39.80	

5-Year Design Storm Runoff Calculations
 (Rational Method Procedure)

BASIN INFORMATION				DIRECT RUNOFF				TOTAL RUNOFF				REMARKS
DESIGN POINT	DRAIN BASIN	AREA Ac	RUNOFF COEFF	T(c) Min	C x A	I In/Hr	Q CFS	T(c) Min	SUM C x A	I In/Hr	Q CFS	
1	1.1	1.43	0.73	5.0	1.05	4.71	4.93	5.0	1.05	4.7	4.93	
1	1.2	1.97	0.73	5.0	1.44	4.71	6.77	5.0	2.5	4.7	11.71	
1	2.0	0.88	0.73	5.0	0.64	4.71	3.00	5.0	3.1	4.7	14.71	
1	3.0	1.97	0.73	5.0	1.44	4.71	6.80	5.0	4.6	4.7	21.50	
1	4.1	1.14	0.73	5.0	0.83	4.71	3.91	5.0	5.4	4.7	25.42	
1	4.2	0.77	0.73	5.0	0.56	4.71	2.65	5.0	6.0	4.7	28.07	
1	5.0	1.13	0.73	5.0	0.83	4.71	3.89	5.0	6.8	4.7	31.96	
1	6.0	2.22	0.73	5.0	1.62	4.71	7.62	5.0	8.4	4.7	39.58	
1	7.0	1.02	0.73	5.0	0.74	4.71	3.48	5.0	9.1	4.7	43.06	
1	8.0	1.94	0.73	6.8	1.41	4.34	6.13	5.0	10.5	4.7	49.72	
1	9.0	0.10	0.86	5.0	0.09	4.71	0.42	5.0	10.6	4.7	50.14	
1	10.0	0.16	0.86	5.0	0.14	4.71	0.65	5.0	10.8	4.7	50.79	
1	11.0	0.21	0.86	5.0	0.18	4.71	0.86	5.0	11.0	4.7	51.64	
1	12.0	0.14	0.86	5.0	0.12	4.71	0.57	5.0	11.1	4.7	52.21	
1	13.0	0.08	0.86	5.0	0.07	4.71	0.32	5.0	11.1	4.7	52.53	
1	14.0	0.17	0.86	5.0	0.14	4.71	0.67	5.0	11.3	4.7	53.20	
1	15.0	0.18	0.86	5.0	0.15	4.71	0.72	5.0	11.4	4.7	53.92	
1	16.0	0.17	0.86	5.0	0.14	4.71	0.67	5.0	11.6	4.7	54.60	
1	17.0	0.11	0.86	5.0	0.10	4.71	0.45	5.0	11.7	4.7	55.05	
1	18.0	0.39	0.86	5.0	0.34	4.71	1.59	5.0	12.0	4.7	56.64	
1	19.0	0.11	0.86	5.0	0.10	4.71	0.45	5.0	12.1	4.7	57.10	
1	20.0	0.03	0.86	5.0	0.02	4.71	0.11	5.0	12.1	4.7	57.21	

100-Year Design Storm Runoff Calculations
(Rational Method Procedure)

BASIN INFORMATION				DIRECT RUNOFF				TOTAL RUNOFF				REMARKS
DESIGN POINT	DRAIN BASIN	AREA Ac	RUNOFF COEFF	T(c) Min	C x A	I In/Hr	Q CFS	T(c) Min	SUM C x A	I In/Hr	Q CFS	
1	1.1	1.43	0.82	5.0	1.18	8.82	10.37	5.0	1.18	8.8	10.37	
1	1.2	1.97	0.82	5.0	1.62	8.82	14.25	5.0	2.8	8.8	24.62	
1	2.0	0.88	0.82	5.0	0.72	8.82	6.33	5.0	3.5	8.8	30.95	
1	3.0	1.97	0.82	5.0	1.62	8.82	14.29	5.0	5.1	8.8	45.24	
1	4.1	1.14	0.82	5.0	0.93	8.82	8.23	5.0	6.1	8.8	53.46	
1	4.2	0.77	0.82	5.0	0.631	8.82	5.56	5.0	6.7	8.8	59.03	
1	5.0	1.13	0.82	5.0	0.928	8.82	8.18	5.0	7.6	8.8	67.21	
1	6.0	2.22	0.82	5.0	1.822	8.82	16.06	5.0	9.4	8.8	83.27	
1	7.0	1.02	0.82	5.0	0.834	8.82	7.35	5.0	10.3	8.8	90.63	
1	8.0	1.94	0.82	6.8	1.589	8.12	12.90	5.0	11.9	8.8	104.64	
1	9.0	0.10	0.89	5.0	0.091	8.82	0.81	5.0	12.0	8.8	105.44	
1	10.0	0.16	0.89	5.0	0.143	8.82	1.26	5.0	12.1	8.8	106.70	
1	11.0	0.21	0.89	5.0	0.188	8.82	1.66	5.0	12.3	8.8	108.36	
1	12.0	0.14	0.89	5.0	0.124	8.82	1.09	5.0	12.4	8.8	109.46	
1	13.0	0.08	0.89	5.0	0.071	8.82	0.62	5.0	12.5	8.8	110.08	
1	14.0	0.17	0.89	5.0	0.147	8.82	1.30	5.0	12.6	8.8	111.38	
1	15.0	0.18	0.89	5.0	0.158	8.82	1.40	5.0	12.8	8.8	112.78	
1	16.0	0.17	0.89	5.0	0.148	8.82	1.30	5.0	12.9	8.8	114.08	
1	17.0	0.11	0.89	5.0	0.099	8.82	0.87	5.0	13.0	8.8	114.95	
1	18.0	0.39	0.89	5.0	0.350	8.82	3.09	5.0	13.4	8.8	118.04	
1	19.0	0.11	0.89	5.0	0.100	8.82	0.88	5.0	13.5	8.8	118.92	
1	20.0	0.03	0.89	5.0	0.025	8.82	0.22	5.0	13.5	8.8	119.14	

DETENTION BASIN STAGE-STORAGE TABLE BUILDER

MHFD-Detention, Version 4.02 (February 2020)

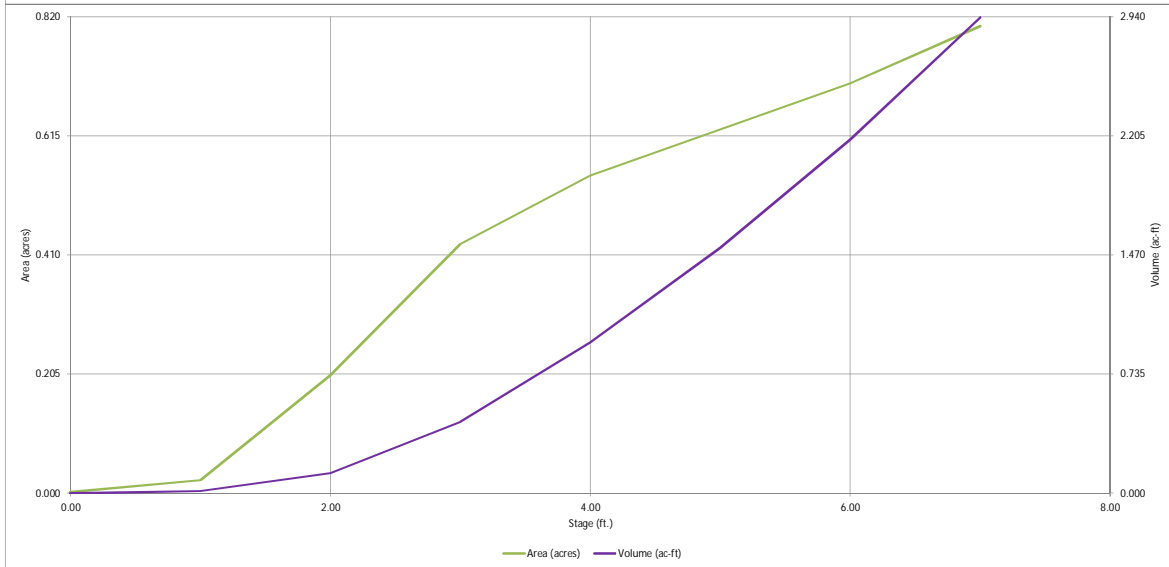
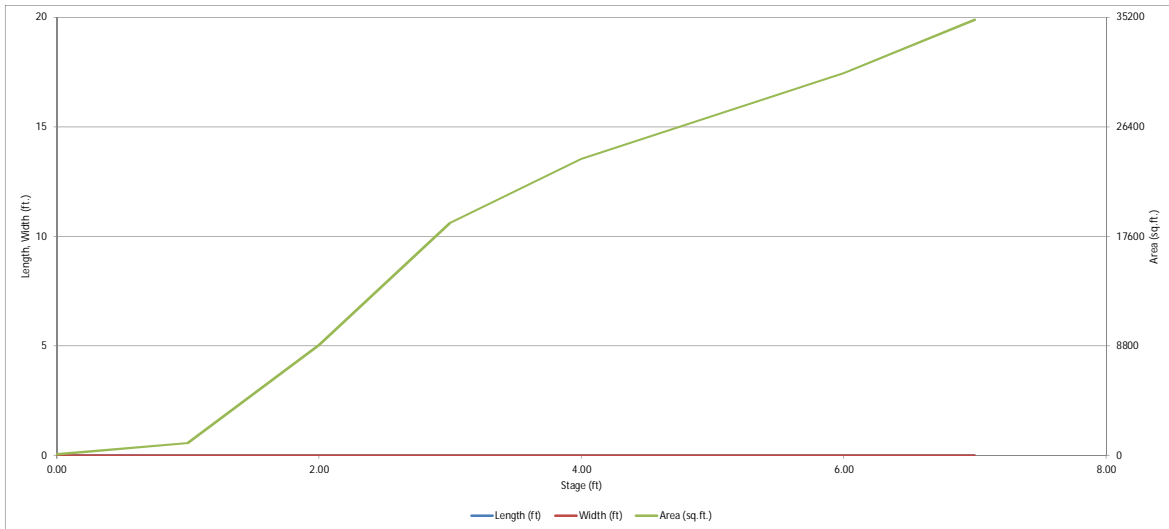

DETENTION BASIN OUTLET STRUCTURE DESIGN

MHFD-Detention, Version 4.02 (February 2020)

Project: Parker Mixed-Use - Parker and Pine

Basin I.D.:

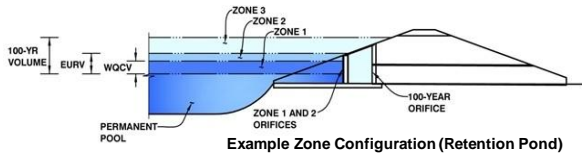

Example Zone Configuration (Retention Pond)

	Estimated Stage (ft)	Estimated Volume (ac-ft)	Outlet Type
Zone 1 (WQCV)	3.10	0.481	Orifice Plate
Zone 2 (EURV)	5.00	1.031	Circular Orifice
Zone 3 (100-year)	6.23	0.826	Weir&Pipe (Rect.)
Total (all zones)		2.339	

User Input: Orifice at Underdrain Outlet (typically used to drain WQCV in a Filtration BMP)

Underdrain Orifice Invert Depth =	N/A	ft (distance below the filtration media surface)	Underdrain Orifice Area =	N/A	ft ²
Underdrain Orifice Diameter =	N/A	inches	Underdrain Orifice Centroid =	N/A	feet

User Input: Orifice Plate with one or more orifices or Elliptical Slot Weir (typically used to drain WQCV and/or EURV in a sedimentation BMP)

Invert of Lowest Orifice =	0.00	ft (relative to basin bottom at Stage = 0 ft)	WQ Orifice Area per Row =	1.056E-02	ft ²
Depth at top of Zone using Orifice Plate =	3.10	ft (relative to basin bottom at Stage = 0 ft)	Elliptical Half-Width =	N/A	feet
Orifice Plate: Orifice Vertical Spacing =	12.40	inches	Elliptical Slot Centroid =	N/A	feet
Orifice Plate: Orifice Area per Row =	1.52	sq. inches (diameter = 1-3/8 inches)	Elliptical Slot Area =	N/A	ft ²

User Input: Stage and Total Area of Each Orifice Row (numbered from lowest to highest)

	Row 1 (required)	Row 2 (optional)	Row 3 (optional)	Row 4 (optional)	Row 5 (optional)	Row 6 (optional)	Row 7 (optional)	Row 8 (optional)
Stage of Orifice Centroid (ft)	0.00	1.03	2.07					
Orifice Area (sq. inches)	1.52	1.52	1.52					

	Row 9 (optional)	Row 10 (optional)	Row 11 (optional)	Row 12 (optional)	Row 13 (optional)	Row 14 (optional)	Row 15 (optional)	Row 16 (optional)
Stage of Orifice Centroid (ft)								
Orifice Area (sq. inches)								

User Input: Vertical Orifice (Circular or Rectangular)

	Zone 2 Circular	Not Selected		Zone 2 Circular	Not Selected
Invert of Vertical Orifice =	3.10	N/A	ft (relative to basin bottom at Stage = 0 ft)	Vertical Orifice Area =	0.35
Depth at top of Zone using Vertical Orifice =	5.00	N/A	ft (relative to basin bottom at Stage = 0 ft)	Vertical Orifice Centroid =	0.33
Vertical Orifice Diameter =	8.00	N/A	inches		

User Input: Overflow Weir (Dropbox with Flat or Sloped Gate and Outlet Pipe OR Rectangular/Trapezoidal Weir (and No Outlet Pipe))

	Zone 3 Weir	Not Selected		Zone 3 Weir	Not Selected
Overflow Weir Front Edge Height, Ho =	4.79	N/A	ft (relative to basin bottom at Stage = 0 ft)	Height of Gate Upper Edge, H ₁ =	6.04
Overflow Weir Front Edge Length =	1.00	N/A	feet	Overflow Weir Slope Length =	5.15
Overflow Weir Gate Slope =	4.00	N/A	H:V	Gate Open Area / 100-yr Orifice Area =	4.68
Horiz. Length of Weir Sides =	5.00	N/A	feet	Overflow Gate Open Area w/o Debris =	3.61
Overflow Gate Open Area % =	70%	N/A	%, gate open area/total area	Overflow Gate Open Area w/ Debris =	1.80
Debris Clogging % =	50%	N/A	%		

User Input: Outlet Pipe w/ Flow Restriction Plate (Circular Orifice, Restrictor Plate, or Rectangular Orifice)

	Zone 3 Rectangular	Not Selected		Zone 3 Rectangular	Not Selected
Depth to Invert of Outlet Pipe =	1.10	N/A	ft (distance below basin bottom at Stage = 0 ft)	Outlet Orifice Area =	0.77
Rectangular Orifice Width =	10.10	N/A	inches	Outlet Orifice Centroid =	0.46
Rectangular Orifice Height =	11.00	N/A	inches	Half-Central Angle of Restrictor Plate on Pipe =	N/A

User Input: Emergency Spillway (Rectangular or Trapezoidal)

Spillway Invert Stage =	6.20	ft (relative to basin bottom at Stage = 0 ft)	Spillway Design Flow Depth =	0.55	feet
Spillway Crest Length =	26.00	feet	Stage at Top of Freeboard =	7.00	feet
Spillway End Slopes =	4.00	H:V	Basin Area at Top of Freeboard =	0.80	acres
Freeboard above Max Water Surface =	0.25	feet	Basin Volume at Top of Freeboard =	2.93	acre-ft

Routed Hydrograph Results

The user can override the default CUHP hydrographs and runoff volumes by entering new values in the Inflow Hydrographs table (Columns W through AF).

	WQCV	EURV	2 Year	5 Year	10 Year	25 Year	50 Year	100 Year	500 Year
Design Storm Return Period									
One-Hour Rainfall Depth (in)	N/A	N/A	0.99	1.39	1.64	1.98	2.31	2.60	3.08
CUHP Runoff Volume (acre-ft)	0.481	1.512	1.094	1.632	1.976	2.479	2.950	3.380	4.070
Inflow Hydrograph Volume (acre-ft)	N/A	N/A	1.094	1.632	1.976	2.479	2.950	3.380	4.070
CUHP Predevelopment Peak Q (cfs)	N/A	N/A	0.1	1.5	2.6	5.9	8.0	10.7	14.0
OPTIONAL Override Predevelopment Peak Q (cfs)	N/A	N/A							
Predevelopment Unit Peak Flow, q (cfs/acre)	N/A	N/A	0.01	0.09	0.16	0.37	0.50	0.67	0.87
Peak Inflow Q (cfs)	N/A	N/A	10.6	15.6	18.4	25.0	29.7	34.2	41.1
Peak Outflow Q (cfs)	0.2	2.6	1.5	2.2	3.1	6.0	8.7	9.7	18.7
Ratio Peak Outflow to Predevelopment Q	N/A	N/A	N/A	1.5	1.2	1.0	1.1	0.9	1.3
Structure Controlling Flow	Plate	Overflow Weir 1	Vertical Orifice 1	Vertical Orifice 1	Overflow Weir 1	Overflow Weir 1	Overflow Weir 1	Outlet Plate 1	Spillway
Max Velocity through Gate 1 (fps)	N/A	0.07	N/A	N/A	0.2	0.9	1.6	1.8	1.8
Max Velocity through Gate 2 (fps)	N/A	N/A	N/A	N/A	N/A	N/A	N/A	N/A	N/A
Time to Drain 97% of Inflow Volume (hours)	38	47	47	48	48	47	46	45	43
Time to Drain 99% of Inflow Volume (hours)	40	51	51	53	53	53	53	52	52
Maximum Ponding Depth (ft)	3.10	5.00	3.97	4.70	5.11	5.55	5.86	6.19	6.43
Area at Maximum Ponding Depth (acres)	0.44	0.63	0.54	0.60	0.63	0.67	0.69	0.72	0.75
Maximum Volume Stored (acre-ft)	0.485	1.515	0.913	1.325	1.584	1.871	2.076	2.316	2.485

DETENTION BASIN OUTLET STRUCTURE DESIGN

MHFD-Detention, Version 4.00 (December 2019)

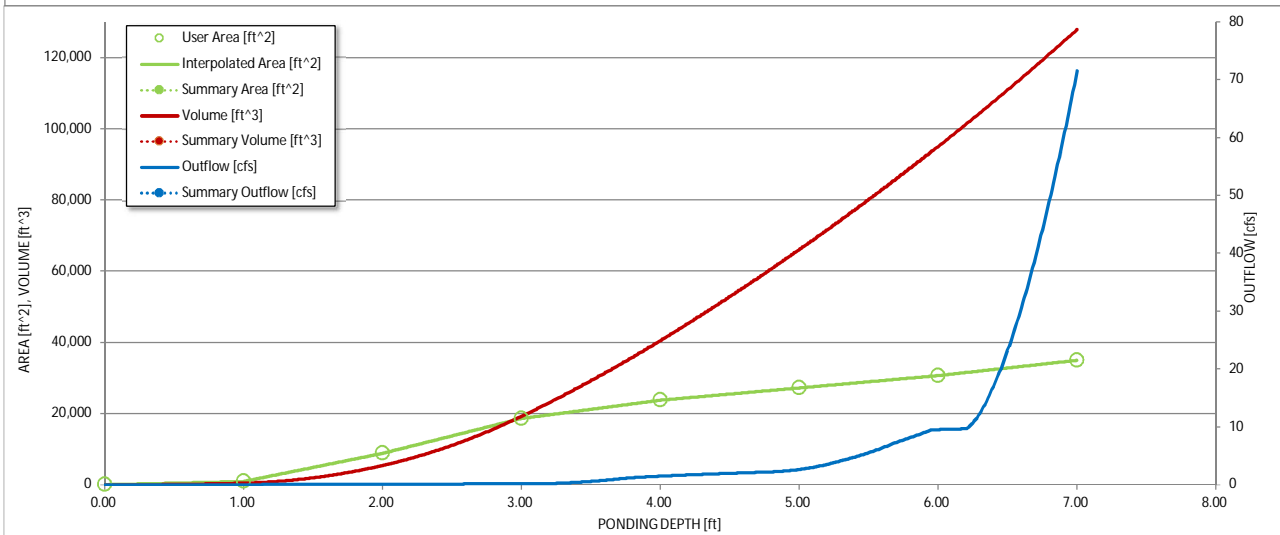
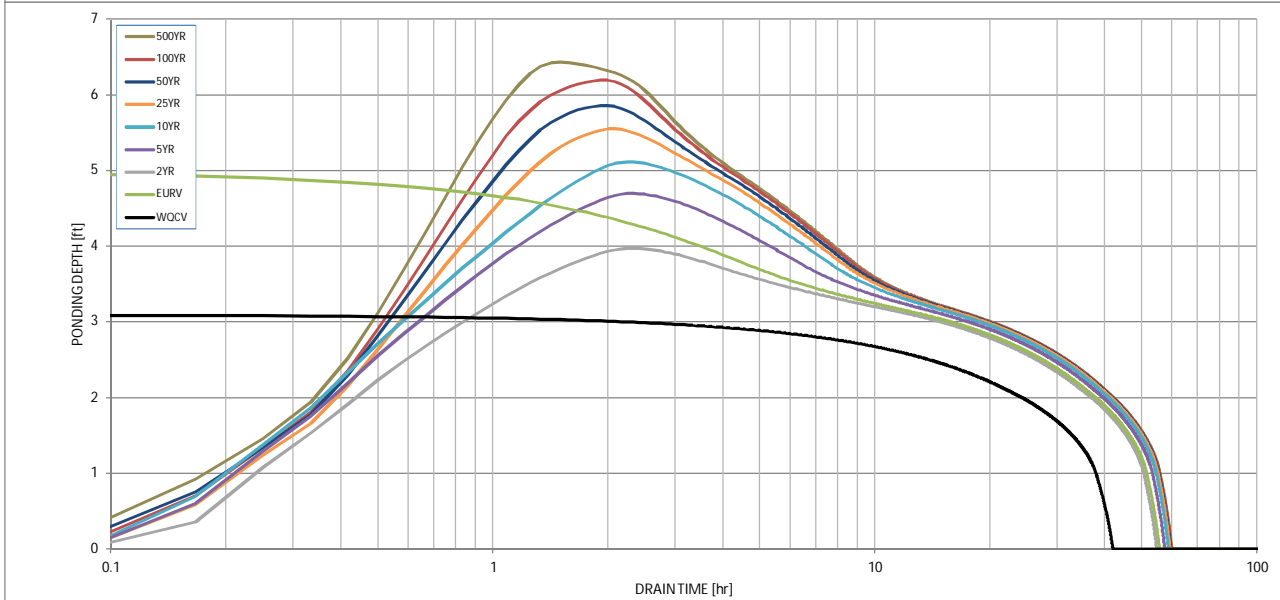
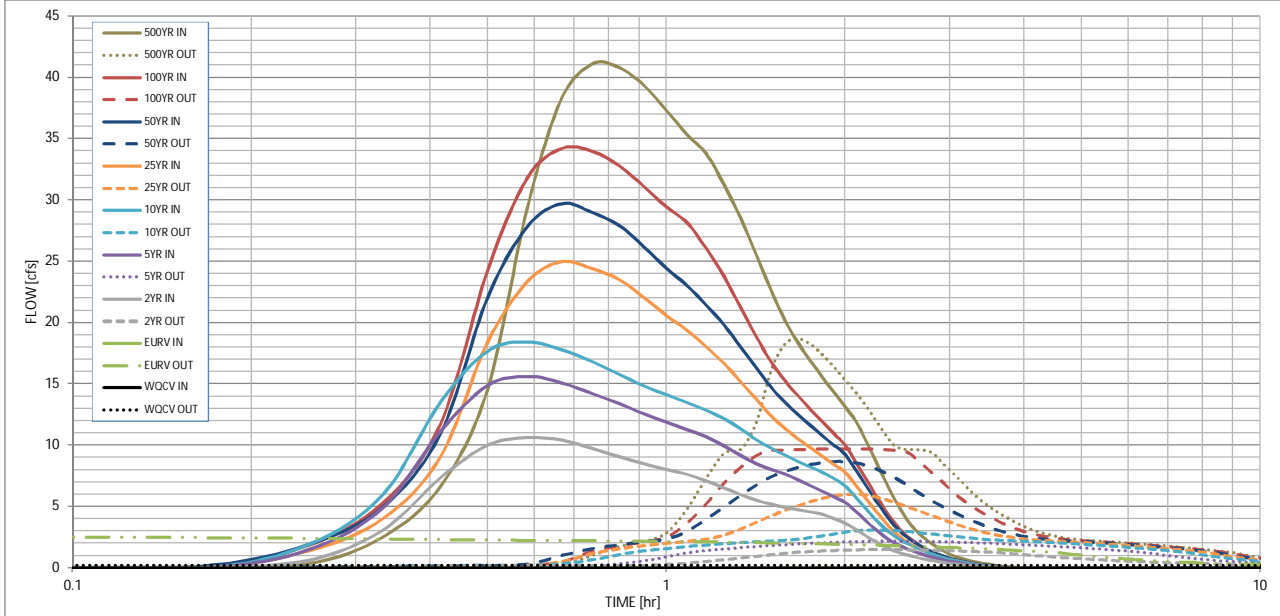

S-A-V-D Chart Axis Override	X-axis	Left Y-Axis	Right Y-Axis
minimum bound			
maximum bound			

ALLOWABLE CAPACITY FOR ONE-HALF OF STREET (Minor & Major Storm)

(Based on Regulated Criteria for Maximum Allowable Flow Depth and Spread)

Project:

Parker & Pine Retail

Inlet ID:

Inlet A04

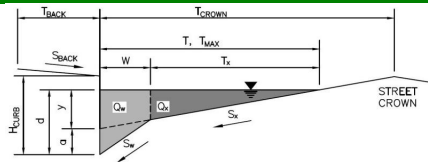

Gutter Geometry (Enter data in the blue cells)

Maximum Allowable Width for Spread Behind Curb
 Side Slope Behind Curb (leave blank for no conveyance credit behind curb)
 Manning's Roughness Behind Curb (typically between 0.012 and 0.020)

T_{BACK} = 0.0 ft
 S_{BACK} = 0.000 ft/ft
 n_{BACK} = 0.012

Height of Curb at Gutter Flow Line
 Distance from Curb Face to Street Crown
 Gutter Width
 Street Transverse Slope
 Gutter Cross Slope (typically 2 inches over 24 inches or 0.083 ft/ft)
 Street Longitudinal Slope - Enter 0 for sump condition
 Manning's Roughness for Street Section (typically between 0.012 and 0.020)

H_{CURB} = 6.00 inches
 T_{CROWN} = 13.0 ft
 W = 1.00 ft
 S_X = 0.020 ft/ft
 S_W = 0.083 ft/ft
 S_0 = 0.000 ft/ft
 n_{STREET} = 0.012

Max. Allowable Spread for Minor & Major Storm
 Max. Allowable Depth at Gutter Flowline for Minor & Major Storm
 Check boxes are not applicable in SUMP conditions

	Minor Storm	Major Storm	
T_{MAX}	13.0	13.0	ft
d_{MAX}	6.0	6.0	inches
	<input type="checkbox"/>	<input type="checkbox"/>	

MINOR STORM Allowable Capacity is based on Depth Criterion
MAJOR STORM Allowable Capacity is based on Depth Criterion

	Minor Storm	Major Storm	
Q_{allow}	SUMP	SUMP	cfs

INLET IN A SUMP OR SAG LOCATION

Version 4.05 Released March 2017

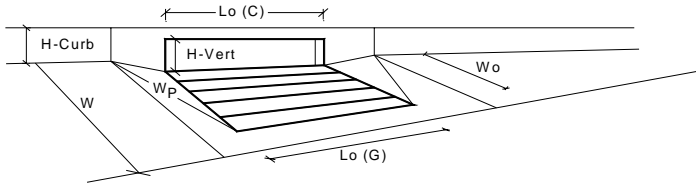

Design Information (Input)	MINOR	MAJOR	
Type of Inlet CDOT Type R Curb Opening	Type = CDOT Type R Curb Opening		
Local Depression (additional to continuous gutter depression 'a' from above)	3.00	3.00	inches
Number of Unit Inlets (Grate or Curb Opening)	1	1	
Water Depth at Flowline (outside of local depression)	3.9	3.9	inches
Grate Information	MINOR	MAJOR	<input type="checkbox"/> Override Depths
Length of a Unit Grate	N/A	N/A	feet
Width of a Unit Grate	N/A	N/A	feet
Area Opening Ratio for a Grate (typical values 0.15-0.90)	N/A	N/A	
Clogging Factor for a Single Grate (typical value 0.50 - 0.70)	N/A	N/A	
Grate Weir Coefficient (typical value 2.15 - 3.60)	N/A	N/A	
Grate Orifice Coefficient (typical value 0.60 - 0.80)	N/A	N/A	
Curb Opening Information	MINOR	MAJOR	
Length of a Unit Curb Opening	5.00	5.00	feet
Height of Vertical Curb Opening in Inches	6.00	6.00	inches
Height of Curb Orifice Throat in Inches	6.00	6.00	inches
Angle of Throat (see USDCM Figure ST-5)	63.40	63.40	degrees
Side Width for Depression Pan (typically the gutter width of 2 feet)	1.00	1.00	feet
Clogging Factor for a Single Curb Opening (typical value 0.10)	0.10	0.10	
Curb Opening Weir Coefficient (typical value 2.3-3.7)	3.60	3.60	
Curb Opening Orifice Coefficient (typical value 0.60 - 0.70)	0.67	0.67	
Low Head Performance Reduction (Calculated)	MINOR	MAJOR	
Depth for Grate Midwidth	N/A	N/A	ft
Depth for Curb Opening Weir Equation	0.24	0.24	ft
Combination Inlet Performance Reduction Factor for Long Inlets	0.50	0.50	
Curb Opening Performance Reduction Factor for Long Inlets	1.00	1.00	
Grated Inlet Performance Reduction Factor for Long Inlets	N/A	N/A	
Total Inlet Interception Capacity (assumes clogged condition)	MINOR	MAJOR	
Inlet Capacity IS GOOD for Minor and Major Storms(>Q PEAK)	2.6	2.6	cfs
Q PEAK REQUIRED	0.4	0.8	cfs

ALLOWABLE CAPACITY FOR ONE-HALF OF STREET (Minor & Major Storm)

(Based on Regulated Criteria for Maximum Allowable Flow Depth and Spread)

Project: **Parker & Pine Retail**
 Inlet ID: **Inlet A02**

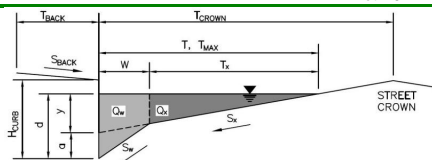

Gutter Geometry (Enter data in the blue cells)					
Maximum Allowable Width for Spread Behind Curb	$T_{BACK} = 0.0$ ft				
Side Slope Behind Curb (leave blank for no conveyance credit behind curb)	$S_{BACK} = 0.000$ ft/ft				
Manning's Roughness Behind Curb (typically between 0.012 and 0.020)	$n_{BACK} = 0.012$				
Height of Curb at Gutter Flow Line	$H_{CURB} = 6.00$ inches				
Distance from Curb Face to Street Crown	$T_{CROWN} = 13.0$ ft				
Gutter Width	$W = 1.00$ ft				
Street Transverse Slope	$S_X = 0.015$ ft/ft				
Gutter Cross Slope (typically 2 inches over 24 inches or 0.083 ft/ft)	$S_W = 0.083$ ft/ft				
Street Longitudinal Slope - Enter 0 for sump condition	$S_0 = 0.006$ ft/ft				
Manning's Roughness for Street Section (typically between 0.012 and 0.020)	$n_{STREET} = 0.012$				
Max. Allowable Spread for Minor & Major Storm	<table border="1"> <thead> <tr> <th>Minor Storm</th> <th>Major Storm</th> </tr> </thead> <tbody> <tr> <td>$T_{MAX} = 13.0$</td> <td>$T_{MAX} = 13.0$</td> </tr> </tbody> </table> ft	Minor Storm	Major Storm	$T_{MAX} = 13.0$	$T_{MAX} = 13.0$
Minor Storm	Major Storm				
$T_{MAX} = 13.0$	$T_{MAX} = 13.0$				
Max. Allowable Depth at Gutter Flowline for Minor & Major Storm	<table border="1"> <thead> <tr> <th>Minor Storm</th> <th>Major Storm</th> </tr> </thead> <tbody> <tr> <td>$d_{MAX} = 6.0$</td> <td>$d_{MAX} = 6.0$</td> </tr> </tbody> </table> inches	Minor Storm	Major Storm	$d_{MAX} = 6.0$	$d_{MAX} = 6.0$
Minor Storm	Major Storm				
$d_{MAX} = 6.0$	$d_{MAX} = 6.0$				
Allow Flow Depth at Street Crown (leave blank for no)	<table border="1"> <thead> <tr> <th>Minor Storm</th> <th>Major Storm</th> </tr> </thead> <tbody> <tr> <td><input type="checkbox"/></td> <td><input type="checkbox"/></td> </tr> </tbody> </table> check = yes	Minor Storm	Major Storm	<input type="checkbox"/>	<input type="checkbox"/>
Minor Storm	Major Storm				
<input type="checkbox"/>	<input type="checkbox"/>				
MINOR STORM Allowable Capacity is based on Spread Criterion					
MAJOR STORM Allowable Capacity is based on Spread Criterion					
Minor storm max. allowable capacity GOOD - greater than the design flow given on sheet 'Inlet Management'					
Major storm max. allowable capacity GOOD - greater than the design flow given on sheet 'Inlet Management'					
	<table border="1"> <thead> <tr> <th>Minor Storm</th> <th>Major Storm</th> </tr> </thead> <tbody> <tr> <td>$Q_{allow} = 3.2$</td> <td>$Q_{allow} = 3.2$</td> </tr> </tbody> </table> cfs	Minor Storm	Major Storm	$Q_{allow} = 3.2$	$Q_{allow} = 3.2$
Minor Storm	Major Storm				
$Q_{allow} = 3.2$	$Q_{allow} = 3.2$				

INLET ON A CONTINUOUS GRADE

Version 4.05 Released March 2017

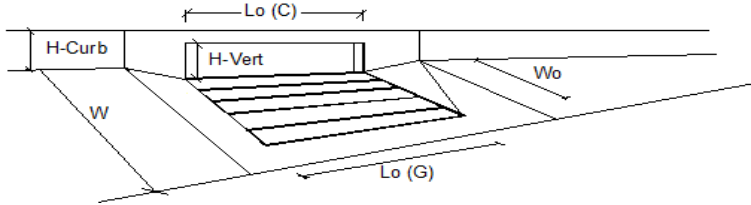

Design Information (Input)	CDOT Type R Curb Opening	MINOR	MAJOR	
Type of Inlet	CDOT Type R Curb Opening	Type =	CDOT Type R Curb Opening	
Local Depression (additional to continuous gutter depression 'a')		$a_{LOCAL} =$	3.0	3.0
Total Number of Units in the Inlet (Grate or Curb Opening)		No =	1	1
Length of a Single Unit Inlet (Grate or Curb Opening)		$L_o =$	5.00	5.00
Width of a Unit Grate (cannot be greater than W, Gutter Width)		$W_o =$	N/A	N/A
Clogging Factor for a Single Unit Grate (typical min. value = 0.5)		$C_r-G =$	N/A	N/A
Clogging Factor for a Single Unit Curb Opening (typical min. value = 0.1)		$C_r-C =$	0.10	0.10
Street Hydraulics: OK - $Q < Q_{allowable}$ Street Capacity.				
Total Inlet Interception Capacity		$Q =$	0.6	1.4
Total Inlet Carry-Over Flow (flow bypassing inlet)		$Q_b =$	0.0	0.3
Capture Percentage = $Q_c/Q_o =$		C% =	100	80
				%

ALLOWABLE CAPACITY FOR ONE-HALF OF STREET (Minor & Major Storm)

(Based on Regulated Criteria for Maximum Allowable Flow Depth and Spread)

Project: **Parker & Pine Retail**
 Inlet ID: **Inlet C00**

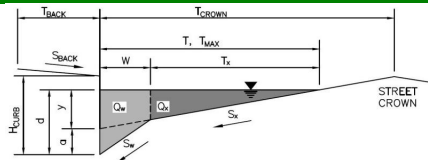

Gutter Geometry (Enter data in the blue cells)

Maximum Allowable Width for Spread Behind Curb
 Side Slope Behind Curb (leave blank for no conveyance credit behind curb)
 Manning's Roughness Behind Curb (typically between 0.012 and 0.020)

$T_{BACK} =$ ft
 $S_{BACK} =$ ft/ft
 $n_{BACK} =$

Height of Curb at Gutter Flow Line
 Distance from Curb Face to Street Crown
 Gutter Width
 Street Transverse Slope
 Gutter Cross Slope (typically 2 inches over 24 inches or 0.083 ft/ft)
 Street Longitudinal Slope - Enter 0 for sump condition
 Manning's Roughness for Street Section (typically between 0.012 and 0.020)

$H_{CURB} =$ inches
 $T_{CROWN} =$ ft
 $W =$ ft
 $S_X =$ ft/ft
 $S_W =$ ft/ft
 $S_0 =$ ft/ft
 $n_{STREET} =$

Max. Allowable Spread for Minor & Major Storm
 Max. Allowable Depth at Gutter Flowline for Minor & Major Storm
 Check boxes are not applicable in SUMP conditions

	Minor Storm	Major Storm	
$T_{MAX} =$	<input type="text" value="13.0"/>	<input type="text" value="13.0"/>	ft
$d_{MAX} =$	<input type="text" value="6.0"/>	<input type="text" value="6.0"/>	inches
	<input type="checkbox"/>	<input type="checkbox"/>	

MINOR STORM Allowable Capacity is based on Depth Criterion
MAJOR STORM Allowable Capacity is based on Depth Criterion

	Minor Storm	Major Storm	
$Q_{allow} =$	<input type="text" value="SUMP"/>	<input type="text" value="SUMP"/>	cfs

INLET IN A SUMP OR SAG LOCATION

Version 4.05 Released March 2017

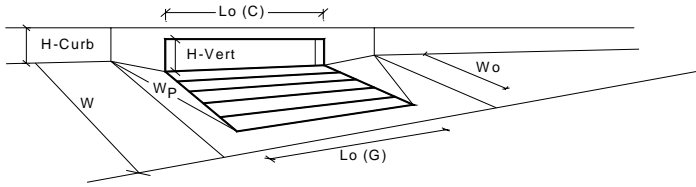

Design Information (Input)	MINOR	MAJOR	
Type of Inlet CDOT Type R Curb Opening	Type = CDOT Type R Curb Opening		
Local Depression (additional to continuous gutter depression 'a' from above)	3.00	3.00	inches
Number of Unit Inlets (Grate or Curb Opening)	1	1	
Water Depth at Flowline (outside of local depression)	3.9	3.9	inches
Grate Information	MINOR	MAJOR	<input type="checkbox"/> Override Depths
Length of a Unit Grate	N/A	N/A	feet
Width of a Unit Grate	N/A	N/A	feet
Area Opening Ratio for a Grate (typical values 0.15-0.90)	N/A	N/A	
Clogging Factor for a Single Grate (typical value 0.50 - 0.70)	N/A	N/A	
Grate Weir Coefficient (typical value 2.15 - 3.60)	N/A	N/A	
Grate Orifice Coefficient (typical value 0.60 - 0.80)	N/A	N/A	
Curb Opening Information	MINOR	MAJOR	
Length of a Unit Curb Opening	5.00	5.00	feet
Height of Vertical Curb Opening in Inches	6.00	6.00	inches
Height of Curb Orifice Throat in Inches	6.00	6.00	inches
Angle of Throat (see USDCM Figure ST-5)	63.40	63.40	degrees
Side Width for Depression Pan (typically the gutter width of 2 feet)	1.00	1.00	feet
Clogging Factor for a Single Curb Opening (typical value 0.10)	0.10	0.10	
Curb Opening Weir Coefficient (typical value 2.3-3.7)	3.60	3.60	
Curb Opening Orifice Coefficient (typical value 0.60 - 0.70)	0.67	0.67	
Low Head Performance Reduction (Calculated)	MINOR	MAJOR	
Depth for Grate Midwidth	N/A	N/A	ft
Depth for Curb Opening Weir Equation	0.24	0.24	ft
Combination Inlet Performance Reduction Factor for Long Inlets	0.50	0.50	
Curb Opening Performance Reduction Factor for Long Inlets	1.00	1.00	
Grated Inlet Performance Reduction Factor for Long Inlets	N/A	N/A	
Total Inlet Interception Capacity (assumes clogged condition)	MINOR	MAJOR	
Inlet Capacity IS GOOD for Minor and Major Storms(>Q PEAK)	2.6	2.6	cfs
Q PEAK REQUIRED	0.7	1.3	cfs

ALLOWABLE CAPACITY FOR ONE-HALF OF STREET (Minor & Major Storm)

(Based on Regulated Criteria for Maximum Allowable Flow Depth and Spread)

Project: **Parker & Pine Retail**
 Inlet ID: **Inlet A01**

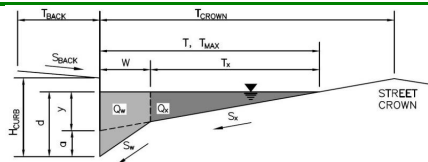

Gutter Geometry (Enter data in the blue cells)

Maximum Allowable Width for Spread Behind Curb
 Side Slope Behind Curb (leave blank for no conveyance credit behind curb)
 Manning's Roughness Behind Curb (typically between 0.012 and 0.020)

T_{BACK} = 0.0 ft
 S_{BACK} = ft/ft
 n_{BACK} = 0.012

Height of Curb at Gutter Flow Line
 Distance from Curb Face to Street Crown
 Gutter Width
 Street Transverse Slope
 Gutter Cross Slope (typically 2 inches over 24 inches or 0.083 ft/ft)
 Street Longitudinal Slope - Enter 0 for sump condition
 Manning's Roughness for Street Section (typically between 0.012 and 0.020)

H_{CURB} = 6.00 inches
 T_{CROWN} = 13.0 ft
 W = 1.00 ft
 S_x = 0.028 ft/ft
 S_w = 0.083 ft/ft
 S_o = 0.000 ft/ft
 n_{STREET} = 0.012

Max. Allowable Spread for Minor & Major Storm
 Max. Allowable Depth at Gutter Flowline for Minor & Major Storm
 Check boxes are not applicable in SUMP conditions

	Minor Storm	Major Storm	
T_{MAX}	13.0	13.0	ft
d_{MAX}	6.0	6.0	inches
	<input type="checkbox"/>	<input type="checkbox"/>	

MINOR STORM Allowable Capacity is based on Depth Criterion
MAJOR STORM Allowable Capacity is based on Depth Criterion

Q_{allow} =

Minor Storm	Major Storm
SUMP	SUMP

 cfs

INLET IN A SUMP OR SAG LOCATION

Version 4.05 Released March 2017

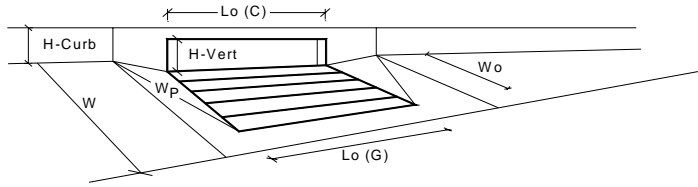

Design Information (Input)	MINOR	MAJOR	
Type of Inlet	CDOT Type R Curb Opening		
Local Depression (additional to continuous gutter depression 'a' from above)	3.00	3.00	inches
Number of Unit Inlets (Grate or Curb Opening)	1	1	
Water Depth at Flowline (outside of local depression)	5.1	5.1	inches
Grate Information	MINOR	MAJOR	<input type="checkbox"/> Override Depths
Length of a Unit Grate	N/A	N/A	feet
Width of a Unit Grate	N/A	N/A	feet
Area Opening Ratio for a Grate (typical values 0.15-0.90)	N/A	N/A	
Clogging Factor for a Single Grate (typical value 0.50 - 0.70)	N/A	N/A	
Grate Weir Coefficient (typical value 2.15 - 3.60)	N/A	N/A	
Grate Orifice Coefficient (typical value 0.60 - 0.80)	N/A	N/A	
Curb Opening Information	MINOR	MAJOR	
Length of a Unit Curb Opening	5.00	5.00	feet
Height of Vertical Curb Opening in Inches	6.00	6.00	inches
Height of Curb Orifice Throat in Inches	6.00	6.00	inches
Angle of Throat (see USDCM Figure ST-5)	63.40	63.40	degrees
Side Width for Depression Pan (typically the gutter width of 2 feet)	1.00	1.00	feet
Clogging Factor for a Single Curb Opening (typical value 0.10)	0.10	0.10	
Curb Opening Weir Coefficient (typical value 2.3-3.7)	3.60	3.60	
Curb Opening Orifice Coefficient (typical value 0.60 - 0.70)	0.67	0.67	
Low Head Performance Reduction (Calculated)	MINOR	MAJOR	
Depth for Grate Midwidth	N/A	N/A	ft
Depth for Curb Opening Weir Equation	0.34	0.34	ft
Combination Inlet Performance Reduction Factor for Long Inlets	0.65	0.65	
Curb Opening Performance Reduction Factor for Long Inlets	1.00	1.00	
Grated Inlet Performance Reduction Factor for Long Inlets	N/A	N/A	
Total Inlet Interception Capacity (assumes clogged condition)	MINOR	MAJOR	
Q_a	4.3	4.3	cfs
Q _{PEAK REQUIRED}	0.7	2.2	cfs

Inlet Capacity IS GOOD for Minor and Major Storms(>Q PEAK)

ALLOWABLE CAPACITY FOR ONE-HALF OF STREET (Minor & Major Storm)

(Based on Regulated Criteria for Maximum Allowable Flow Depth and Spread)

Project: **Parker & Pine Retail**
 Inlet ID: **Inlet B05**

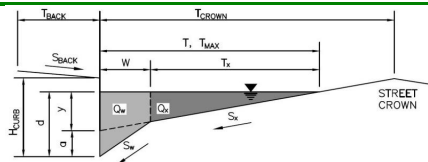

Gutter Geometry (Enter data in the blue cells)

Maximum Allowable Width for Spread Behind Curb
 Side Slope Behind Curb (leave blank for no conveyance credit behind curb)
 Manning's Roughness Behind Curb (typically between 0.012 and 0.020)

$T_{BACK} =$ ft
 $S_{BACK} =$ ft/ft
 $n_{BACK} =$

Height of Curb at Gutter Flow Line
 Distance from Curb Face to Street Crown
 Gutter Width
 Street Transverse Slope
 Gutter Cross Slope (typically 2 inches over 24 inches or 0.083 ft/ft)
 Street Longitudinal Slope - Enter 0 for sump condition
 Manning's Roughness for Street Section (typically between 0.012 and 0.020)

$H_{CURB} =$ inches
 $T_{CROWN} =$ ft
 $W =$ ft
 $S_X =$ ft/ft
 $S_W =$ ft/ft
 $S_0 =$ ft/ft
 $n_{STREET} =$

Max. Allowable Spread for Minor & Major Storm
 Max. Allowable Depth at Gutter Flowline for Minor & Major Storm
 Allow Flow Depth at Street Crown (leave blank for no)

	Minor Storm	Major Storm	
$T_{MAX} =$	<input type="text" value="13.0"/>	<input type="text" value="13.0"/>	ft
$d_{MAX} =$	<input type="text" value="6.0"/>	<input type="text" value="6.0"/>	inches
	<input type="checkbox"/>	<input type="checkbox"/>	check = yes

MINOR STORM Allowable Capacity is based on Spread Criterion
MAJOR STORM Allowable Capacity is based on Spread Criterion

	Minor Storm	Major Storm	
$Q_{allow} =$	<input type="text" value="8.7"/>	<input type="text" value="8.7"/>	cfs

Minor storm max. allowable capacity GOOD - greater than the design flow given on sheet 'Inlet Management'
Major storm max. allowable capacity GOOD - greater than the design flow given on sheet 'Inlet Management'

INLET ON A CONTINUOUS GRADE

Version 4.05 Released March 2017

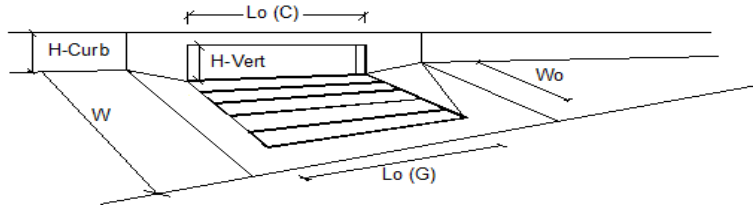

Design Information (Input)	CDOT Type R Curb Opening	MINOR	MAJOR	
Type of Inlet	CDOT Type R Curb Opening	Type =	CDOT Type R Curb Opening	
Local Depression (additional to continuous gutter depression 'a')		$a_{LOCAL} =$	3.0	3.0 inches
Total Number of Units in the Inlet (Grate or Curb Opening)		No =	1	1
Length of a Single Unit Inlet (Grate or Curb Opening)		$L_o =$	5.00	5.00 ft
Width of a Unit Grate (cannot be greater than W, Gutter Width)		$W_o =$	N/A	N/A ft
Clogging Factor for a Single Unit Grate (typical min. value = 0.5)		$C_r-G =$	N/A	N/A
Clogging Factor for a Single Unit Curb Opening (typical min. value = 0.1)		$C_r-C =$	0.10	0.10
Street Hydraulics: OK - $Q < Q_{allowable}$ Street Capacity.				
Total Inlet Interception Capacity		Q =	0.7	1.3 cfs
Total Inlet Carry-Over Flow (flow bypassing inlet)		$Q_b =$	0.0	0.1 cfs
Capture Percentage = $Q_i/Q_o =$		C% =	100	90 %

ALLOWABLE CAPACITY FOR ONE-HALF OF STREET (Minor & Major Storm)

(Based on Regulated Criteria for Maximum Allowable Flow Depth and Spread)

Project: **Parker & Pine Retail**
 Inlet ID: **Inlet B03**

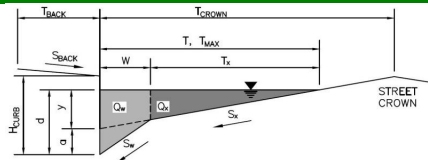

Gutter Geometry (Enter data in the blue cells)

Maximum Allowable Width for Spread Behind Curb
 Side Slope Behind Curb (leave blank for no conveyance credit behind curb)
 Manning's Roughness Behind Curb (typically between 0.012 and 0.020)

$T_{BACK} =$ ft
 $S_{BACK} =$ ft/ft
 $n_{BACK} =$

Height of Curb at Gutter Flow Line
 Distance from Curb Face to Street Crown

$H_{CURB} =$ inches
 $T_{CROWN} =$ ft

Gutter Width

$W =$ ft

Street Transverse Slope

$S_X =$ ft/ft

Gutter Cross Slope (typically 2 inches over 24 inches or 0.083 ft/ft)

$S_W =$ ft/ft

Street Longitudinal Slope - Enter 0 for sump condition

$S_0 =$ ft/ft

Manning's Roughness for Street Section (typically between 0.012 and 0.020)

$n_{STREET} =$

Max. Allowable Spread for Minor & Major Storm

	Minor Storm	Major Storm	
$T_{MAX} =$	<input type="text" value="13.0"/>	<input type="text" value="13.0"/>	ft

Max. Allowable Depth at Gutter Flowline for Minor & Major Storm

	Minor Storm	Major Storm	
$d_{MAX} =$	<input type="text" value="6.0"/>	<input type="text" value="6.0"/>	inches

Allow Flow Depth at Street Crown (leave blank for no)

check = yes

MINOR STORM Allowable Capacity is based on Spread Criterion

MAJOR STORM Allowable Capacity is based on Spread Criterion

	Minor Storm	Major Storm	
$Q_{allow} =$	<input type="text" value="12.0"/>	<input type="text" value="12.0"/>	cfs

Minor storm max. allowable capacity GOOD - greater than the design flow given on sheet 'Inlet Management'

Major storm max. allowable capacity GOOD - greater than the design flow given on sheet 'Inlet Management'

INLET ON A CONTINUOUS GRADE

Version 4.05 Released March 2017

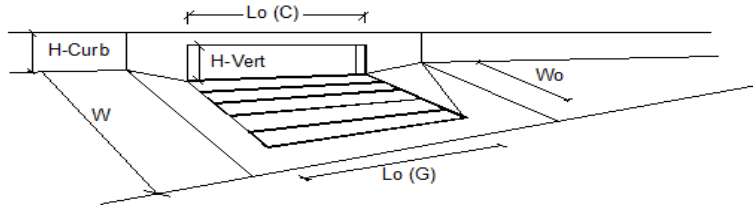

Design Information (Input)	MINOR		MAJOR	
Type of Inlet	CDOT Type R Curb Opening			
Local Depression (additional to continuous gutter depression 'a')	3.0	3.0	inches	
Total Number of Units in the Inlet (Grate or Curb Opening)	1	1		
Length of a Single Unit Inlet (Grate or Curb Opening)	5.00	5.00	ft	
Width of a Unit Grate (cannot be greater than W, Gutter Width)	N/A	N/A	ft	
Clogging Factor for a Single Unit Grate (typical min. value = 0.5)	N/A	N/A		
Clogging Factor for a Single Unit Curb Opening (typical min. value = 0.1)	0.10	0.10		
Street Hydraulics: OK - Q < Allowable Street Capacity.				
Total Inlet Interception Capacity	0.7	1.2	cfs	
Total Inlet Carry-Over Flow (flow bypassing inlet)	0.0	0.1	cfs	
Capture Percentage = Q_i/Q_o =	100	93	%	

ALLOWABLE CAPACITY FOR ONE-HALF OF STREET (Minor & Major Storm)

(Based on Regulated Criteria for Maximum Allowable Flow Depth and Spread)

Project: **Parker & Pine Retail**
 Inlet ID: **Inlet B08**

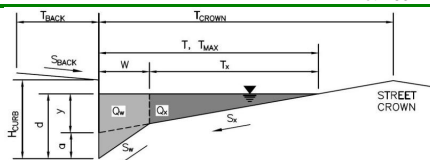

Gutter Geometry (Enter data in the blue cells)

Maximum Allowable Width for Spread Behind Curb
 Side Slope Behind Curb (leave blank for no conveyance credit behind curb)
 Manning's Roughness Behind Curb (typically between 0.012 and 0.020)

T_{BACK} = 0.0 ft
 S_{BACK} = ft/ft
 n_{BACK} = 0.012

Height of Curb at Gutter Flow Line
 Distance from Curb Face to Street Crown
 Gutter Width
 Street Transverse Slope
 Gutter Cross Slope (typically 2 inches over 24 inches or 0.083 ft/ft)
 Street Longitudinal Slope - Enter 0 for sump condition
 Manning's Roughness for Street Section (typically between 0.012 and 0.020)

H_{CURB} = 6.00 inches
 T_{CROWN} = 13.0 ft
 W = 1.00 ft
 S_x = 0.020 ft/ft
 S_W = 0.083 ft/ft
 S_o = 0.000 ft/ft
 n_{STREET} = 0.012

Max. Allowable Spread for Minor & Major Storm
 Max. Allowable Depth at Gutter Flowline for Minor & Major Storm
 Check boxes are not applicable in SUMP conditions

	Minor Storm	Major Storm	
T_{MAX} =	13.0	13.0	ft
d_{MAX} =	6.0	9.0	inches
	<input type="checkbox"/>	<input type="checkbox"/>	

MINOR STORM Allowable Capacity is based on Depth Criterion
MAJOR STORM Allowable Capacity is based on Depth Criterion

Q_{allow} =

Minor Storm	Major Storm	
SUMP	SUMP	cfs

INLET IN A SUMP OR SAG LOCATION

Version 4.05 Released March 2017

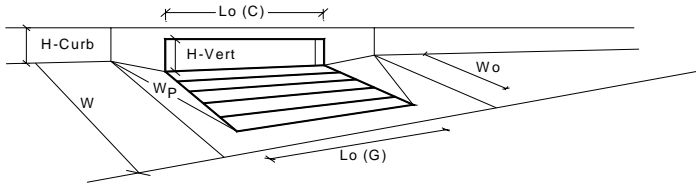

Design Information (Input)	MINOR	MAJOR	
Type of Inlet	CDOT Type R Curb Opening		
Local Depression (additional to continuous gutter depression 'a' from above)	3.00	3.00	inches
Number of Unit Inlets (Grate or Curb Opening)	1	1	
Water Depth at Flowline (outside of local depression)	3.9	3.9	inches
Grate Information	MINOR	MAJOR	<input type="checkbox"/> Override Depths
Length of a Unit Grate	N/A	N/A	feet
Width of a Unit Grate	N/A	N/A	feet
Area Opening Ratio for a Grate (typical values 0.15-0.90)	N/A	N/A	
Clogging Factor for a Single Grate (typical value 0.50 - 0.70)	N/A	N/A	
Grate Weir Coefficient (typical value 2.15 - 3.60)	N/A	N/A	
Grate Orifice Coefficient (typical value 0.60 - 0.80)	N/A	N/A	
Curb Opening Information	MINOR	MAJOR	
Length of a Unit Curb Opening	5.00	5.00	feet
Height of Vertical Curb Opening in Inches	6.00	6.00	inches
Height of Curb Orifice Throat in Inches	6.00	6.00	inches
Angle of Throat (see USDCM Figure ST-5)	63.40	63.40	degrees
Side Width for Depression Pan (typically the gutter width of 2 feet)	1.00	1.00	feet
Clogging Factor for a Single Curb Opening (typical value 0.10)	0.10	0.10	
Curb Opening Weir Coefficient (typical value 2.3-3.7)	3.60	3.60	
Curb Opening Orifice Coefficient (typical value 0.60 - 0.70)	0.67	0.67	
Low Head Performance Reduction (Calculated)	MINOR	MAJOR	
Depth for Grate Midwidth	N/A	N/A	ft
Depth for Curb Opening Weir Equation	0.24	0.24	ft
Combination Inlet Performance Reduction Factor for Long Inlets	0.50	0.50	
Curb Opening Performance Reduction Factor for Long Inlets	1.00	1.00	
Grated Inlet Performance Reduction Factor for Long Inlets	N/A	N/A	
Total Inlet Interception Capacity (assumes clogged condition)	MINOR	MAJOR	
Inlet Capacity IS GOOD for Minor and Major Storms(>Q PEAK)	2.6	2.6	cfs
$Q_{PEAK\ REQUIRED}$	0.5	0.9	cfs

ALLOWABLE CAPACITY FOR ONE-HALF OF STREET (Minor & Major Storm)

(Based on Regulated Criteria for Maximum Allowable Flow Depth and Spread)

Project: **Parker & Pine Retail**
 Inlet ID: **Inlet B00**

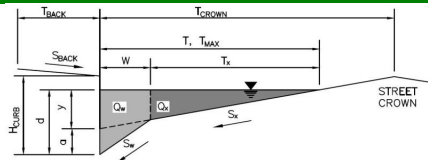

Gutter Geometry (Enter data in the blue cells)

Maximum Allowable Width for Spread Behind Curb
 Side Slope Behind Curb (leave blank for no conveyance credit behind curb)
 Manning's Roughness Behind Curb (typically between 0.012 and 0.020)

$T_{BACK} =$ ft
 $S_{BACK} =$ ft/ft
 $n_{BACK} =$

Height of Curb at Gutter Flow Line
 Distance from Curb Face to Street Crown

$H_{CURB} =$ inches
 $T_{CROWN} =$ ft

Gutter Width
 Street Transverse Slope
 Gutter Cross Slope (typically 2 inches over 24 inches or 0.083 ft/ft)
 Street Longitudinal Slope - Enter 0 for sump condition
 Manning's Roughness for Street Section (typically between 0.012 and 0.020)

$W =$ ft
 $S_X =$ ft/ft
 $S_W =$ ft/ft
 $S_0 =$ ft/ft
 $n_{STREET} =$

Max. Allowable Spread for Minor & Major Storm
 Max. Allowable Depth at Gutter Flowline for Minor & Major Storm
 Allow Flow Depth at Street Crown (leave blank for no)

	Minor Storm	Major Storm	
$T_{MAX} =$	<input type="text" value="13.0"/>	<input type="text" value="13.0"/>	ft
$d_{MAX} =$	<input type="text" value="6.0"/>	<input type="text" value="6.0"/>	inches
	<input type="checkbox"/>	<input type="checkbox"/>	check = yes

MINOR STORM Allowable Capacity is based on Spread Criterion
MAJOR STORM Allowable Capacity is based on Spread Criterion

	Minor Storm	Major Storm	
$Q_{allow} =$	<input type="text" value="5.9"/>	<input type="text" value="5.9"/>	cfs

Minor storm max. allowable capacity GOOD - greater than the design flow given on sheet 'Inlet Management'
Major storm max. allowable capacity GOOD - greater than the design flow given on sheet 'Inlet Management'

INLET ON A CONTINUOUS GRADE

Version 4.05 Released March 2017

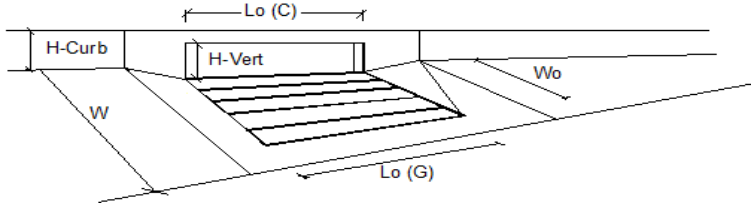

Design Information (Input)	MINOR		MAJOR	
Type of Inlet	CDOT Type R Curb Opening			
Local Depression (additional to continuous gutter depression 'a')	3.0	3.0	inches	
Total Number of Units in the Inlet (Grate or Curb Opening)	1	1		
Length of a Single Unit Inlet (Grate or Curb Opening)	5.00	5.00	ft	
Width of a Unit Grate (cannot be greater than W, Gutter Width)	N/A	N/A	ft	
Clogging Factor for a Single Unit Grate (typical min. value = 0.5)	N/A	N/A		
Clogging Factor for a Single Unit Curb Opening (typical min. value = 0.1)	0.10	0.10		
Street Hydraulics: OK - Q < Allowable Street Capacity.				
Total Inlet Interception Capacity	Q = 0.3	1.6	cfs	
Total Inlet Carry-Over Flow (flow bypassing inlet)	Q _b = 0.0	0.6	cfs	
Capture Percentage = Q _i /Q _o =	C% = 100	72	%	

ALLOWABLE CAPACITY FOR ONE-HALF OF STREET (Minor & Major Storm)

(Based on Regulated Criteria for Maximum Allowable Flow Depth and Spread)

Project: **Parker & Pine Retail**
 Inlet ID: **Inlet C01**

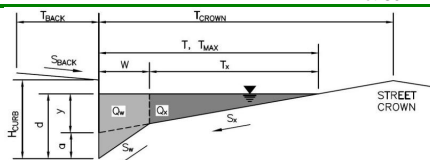

Gutter Geometry (Enter data in the blue cells)																	
Maximum Allowable Width for Spread Behind Curb	$T_{BACK} = 0.0$ ft																
Side Slope Behind Curb (leave blank for no conveyance credit behind curb)	$S_{BACK} =$ ft/ft																
Manning's Roughness Behind Curb (typically between 0.012 and 0.020)	$n_{BACK} = 0.012$																
Height of Curb at Gutter Flow Line	$H_{CURB} = 6.00$ inches																
Distance from Curb Face to Street Crown	$T_{CROWN} = 13.0$ ft																
Gutter Width	$W = 1.00$ ft																
Street Transverse Slope	$S_X = 0.020$ ft/ft																
Gutter Cross Slope (typically 2 inches over 24 inches or 0.083 ft/ft)	$S_W = 0.083$ ft/ft																
Street Longitudinal Slope - Enter 0 for sump condition	$S_0 = 0.028$ ft/ft																
Manning's Roughness for Street Section (typically between 0.012 and 0.020)	$n_{STREET} = 0.012$																
Max. Allowable Spread for Minor & Major Storm	<table border="1"> <thead> <tr> <th></th> <th>Minor Storm</th> <th>Major Storm</th> <th></th> </tr> </thead> <tbody> <tr> <td>$T_{MAX} =$</td> <td>13.0</td> <td>13.0</td> <td>ft</td> </tr> <tr> <td>$d_{MAX} =$</td> <td>6.0</td> <td>6.0</td> <td>inches</td> </tr> <tr> <td></td> <td><input type="checkbox"/></td> <td><input type="checkbox"/></td> <td>check = yes</td> </tr> </tbody> </table>		Minor Storm	Major Storm		$T_{MAX} =$	13.0	13.0	ft	$d_{MAX} =$	6.0	6.0	inches		<input type="checkbox"/>	<input type="checkbox"/>	check = yes
	Minor Storm	Major Storm															
$T_{MAX} =$	13.0	13.0	ft														
$d_{MAX} =$	6.0	6.0	inches														
	<input type="checkbox"/>	<input type="checkbox"/>	check = yes														
Max. Allowable Depth at Gutter Flowline for Minor & Major Storm																	
Allow Flow Depth at Street Crown (leave blank for no)																	
MINOR STORM Allowable Capacity is based on Spread Criterion																	
MAJOR STORM Allowable Capacity is based on Spread Criterion																	
Minor storm max. allowable capacity GOOD - greater than the design flow given on sheet 'Inlet Management'																	
Major storm max. allowable capacity GOOD - greater than the design flow given on sheet 'Inlet Management'																	
	<table border="1"> <thead> <tr> <th></th> <th>Minor Storm</th> <th>Major Storm</th> <th></th> </tr> </thead> <tbody> <tr> <td>$Q_{allow} =$</td> <td>11.3</td> <td>11.3</td> <td>cfs</td> </tr> </tbody> </table>		Minor Storm	Major Storm		$Q_{allow} =$	11.3	11.3	cfs								
	Minor Storm	Major Storm															
$Q_{allow} =$	11.3	11.3	cfs														

INLET ON A CONTINUOUS GRADE

Version 4.05 Released March 2017

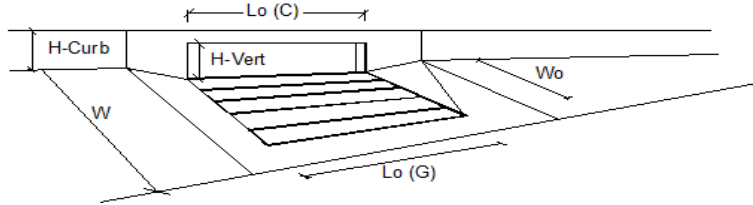

Design Information (Input)	MINOR	MAJOR	
Type of Inlet	CDOT Type R Curb Opening		
Local Depression (additional to continuous gutter depression 'a')	3.0	3.0	inches
Total Number of Units in the Inlet (Grate or Curb Opening)	1	1	
Length of a Single Unit Inlet (Grate or Curb Opening)	5.00	5.00	ft
Width of a Unit Grate (cannot be greater than W, Gutter Width)	N/A	N/A	ft
Clogging Factor for a Single Unit Grate (typical min. value = 0.5)	N/A	N/A	
Clogging Factor for a Single Unit Curb Opening (typical min. value = 0.1)	0.10	0.10	
Street Hydraulics: OK - $Q < Q_{allowable}$ Street Capacity.			
Total Inlet Interception Capacity	0.9	1.4	cfs
Total Inlet Carry-Over Flow (flow bypassing inlet)	0.0	0.2	cfs
Capture Percentage = Q_i/Q_o =	100	85	%

Profile Report

Profile Main A (5-Year)

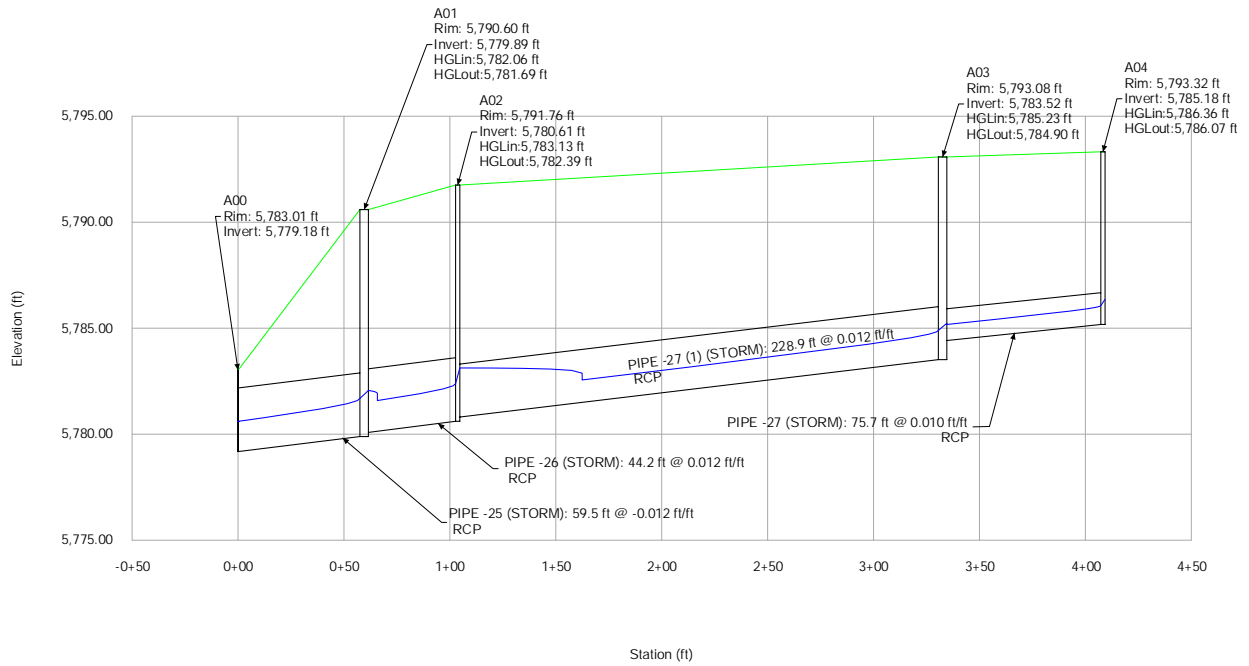

Profile Report

Profile Main A (100-Year)

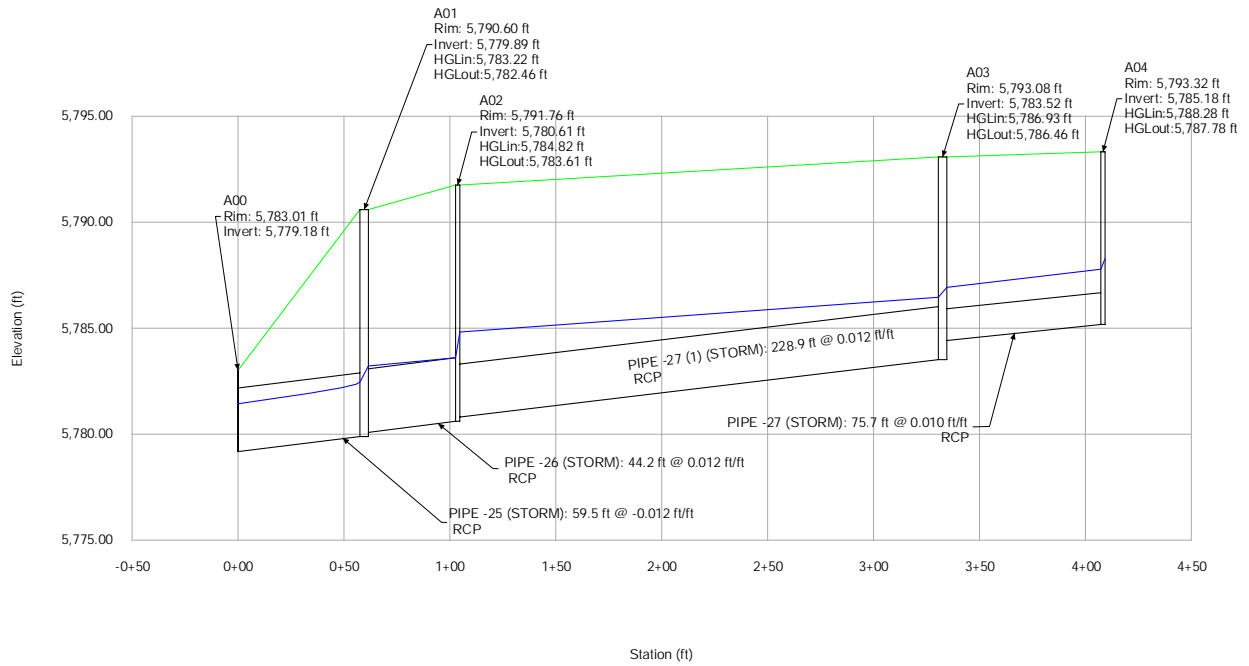

Profile Report
Profile Lateral A.1 (5-Year)

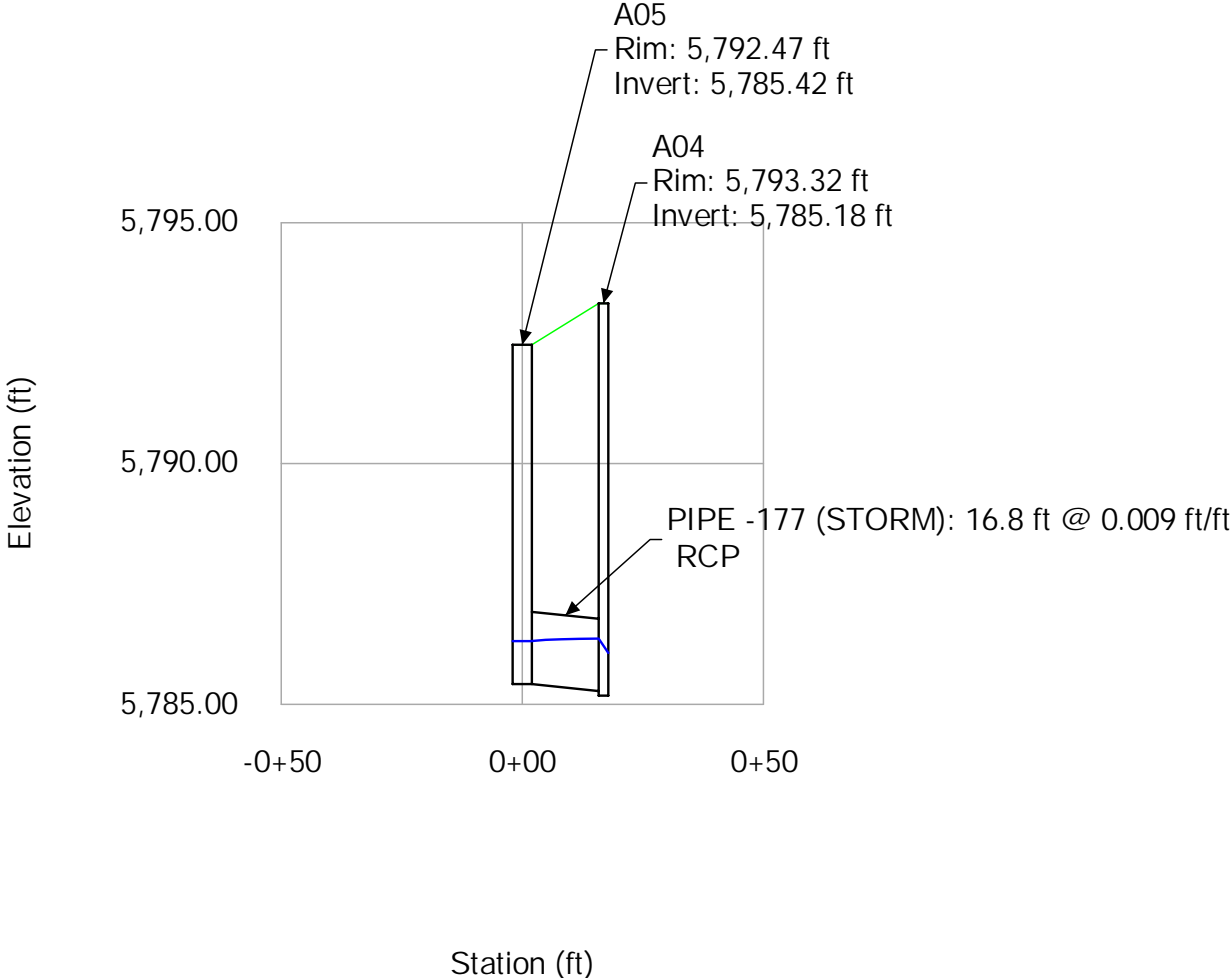

Profile Report

Profile Lateral A.1 (100-Year)

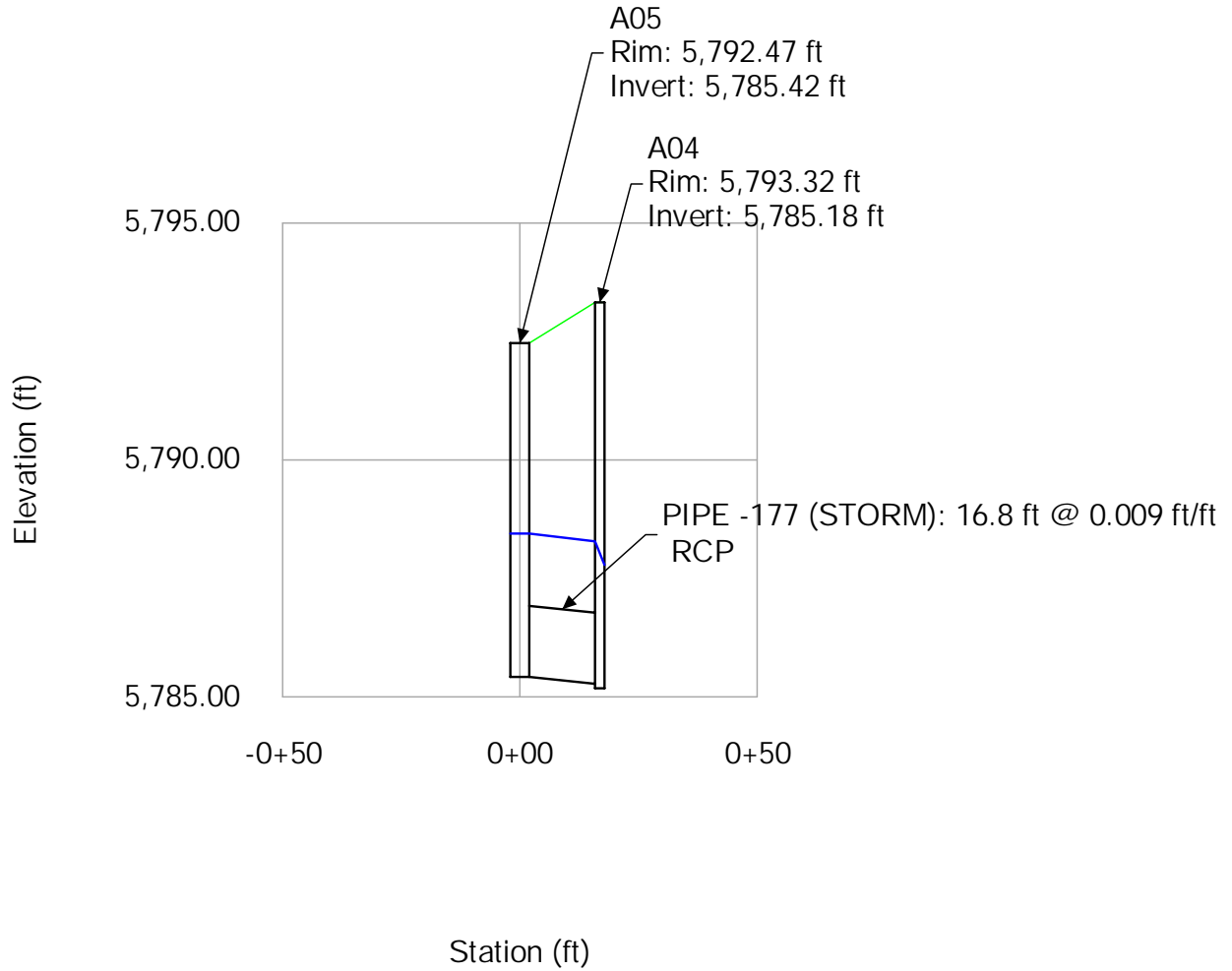

Profile Report Profile Main B (5-Year)

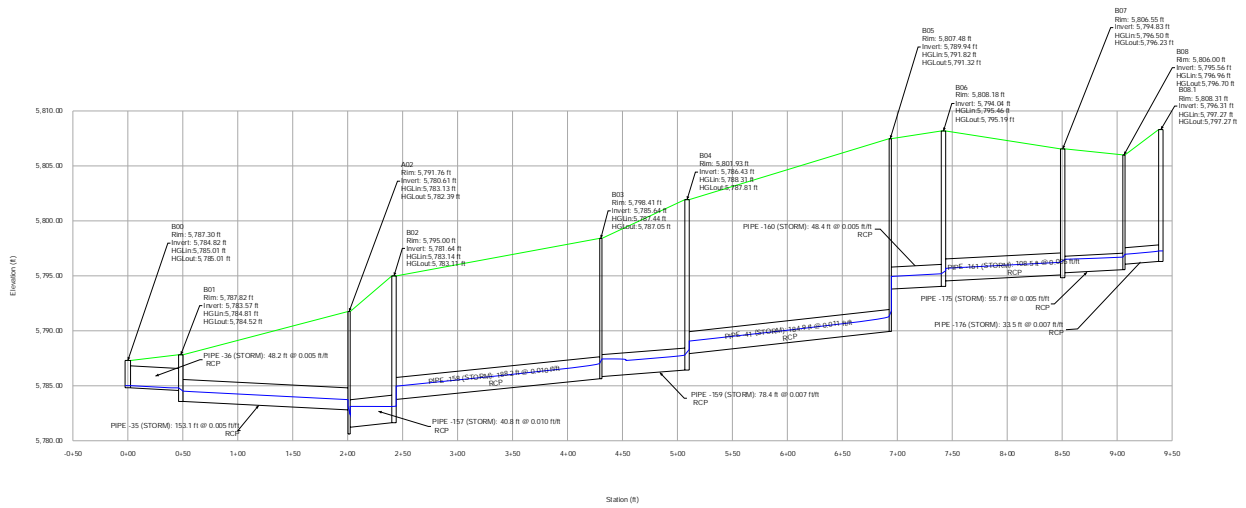

Profile Report

Profile Main B (100-Year)

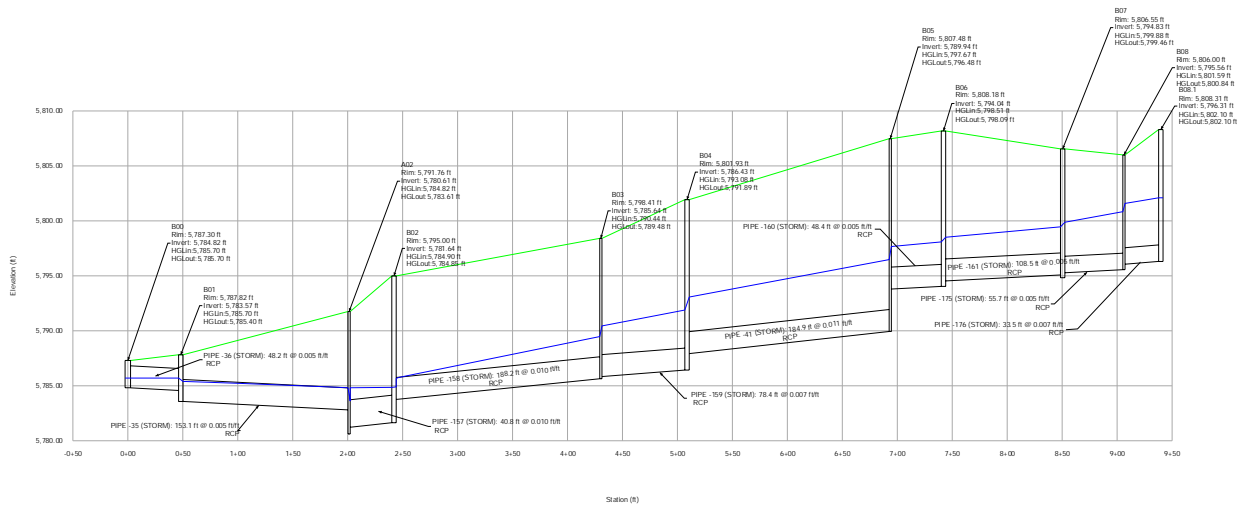

Profile Report

Profile Lateral B.1 (5-Year)

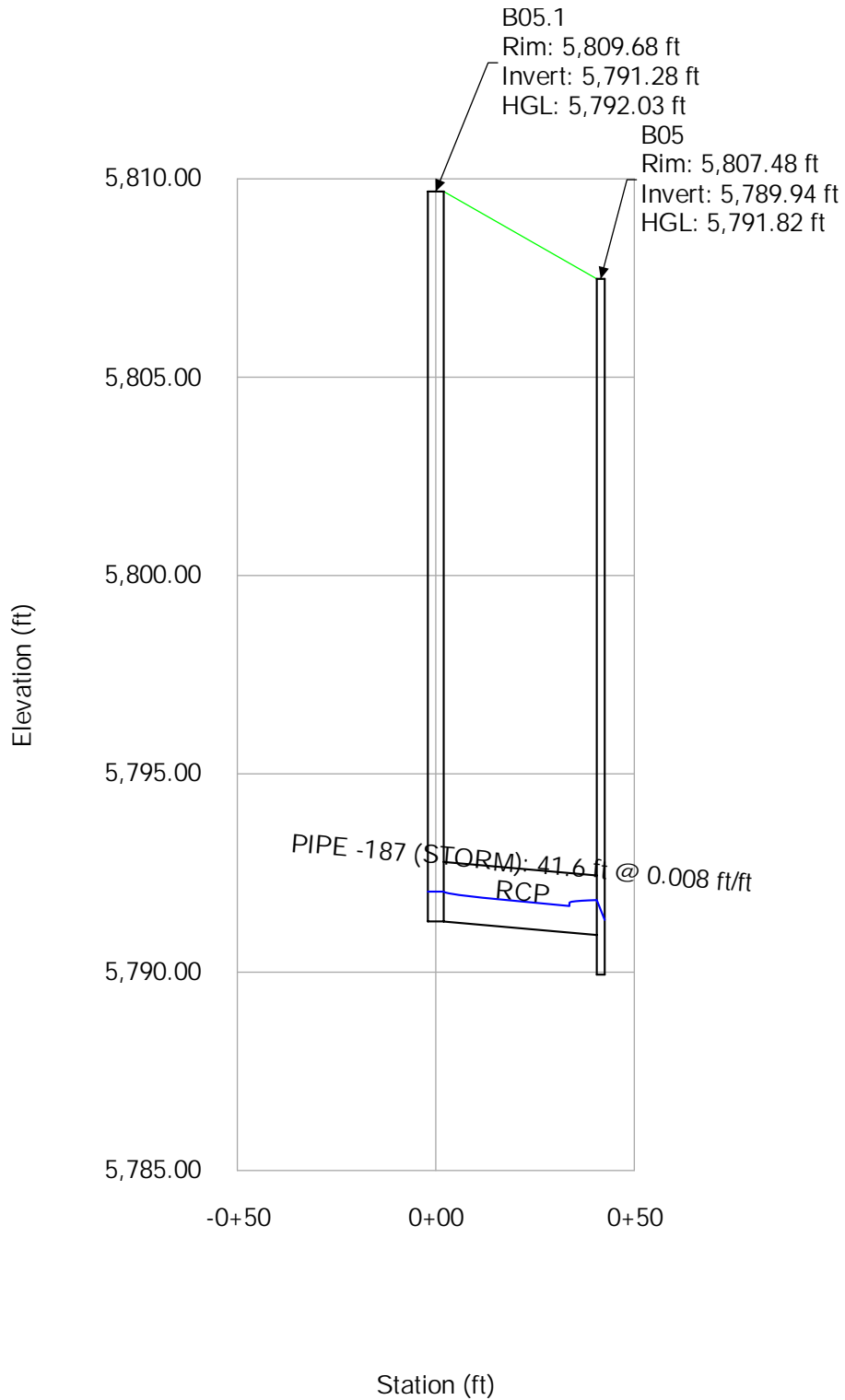

Profile Report

Profile Lateral B.1 (100-Year)

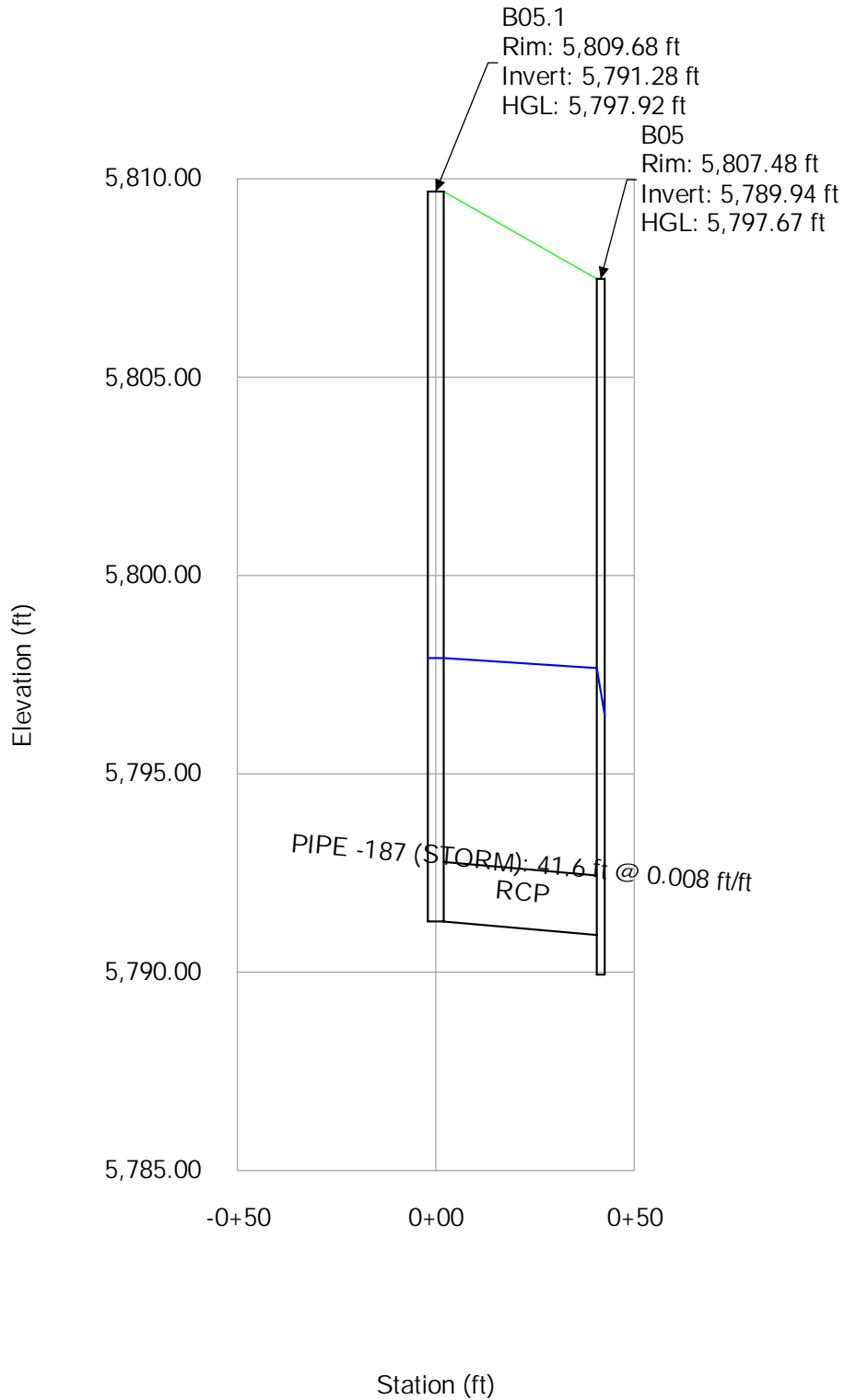

Profile Report

Profile Lateral B.2 (5-Year)

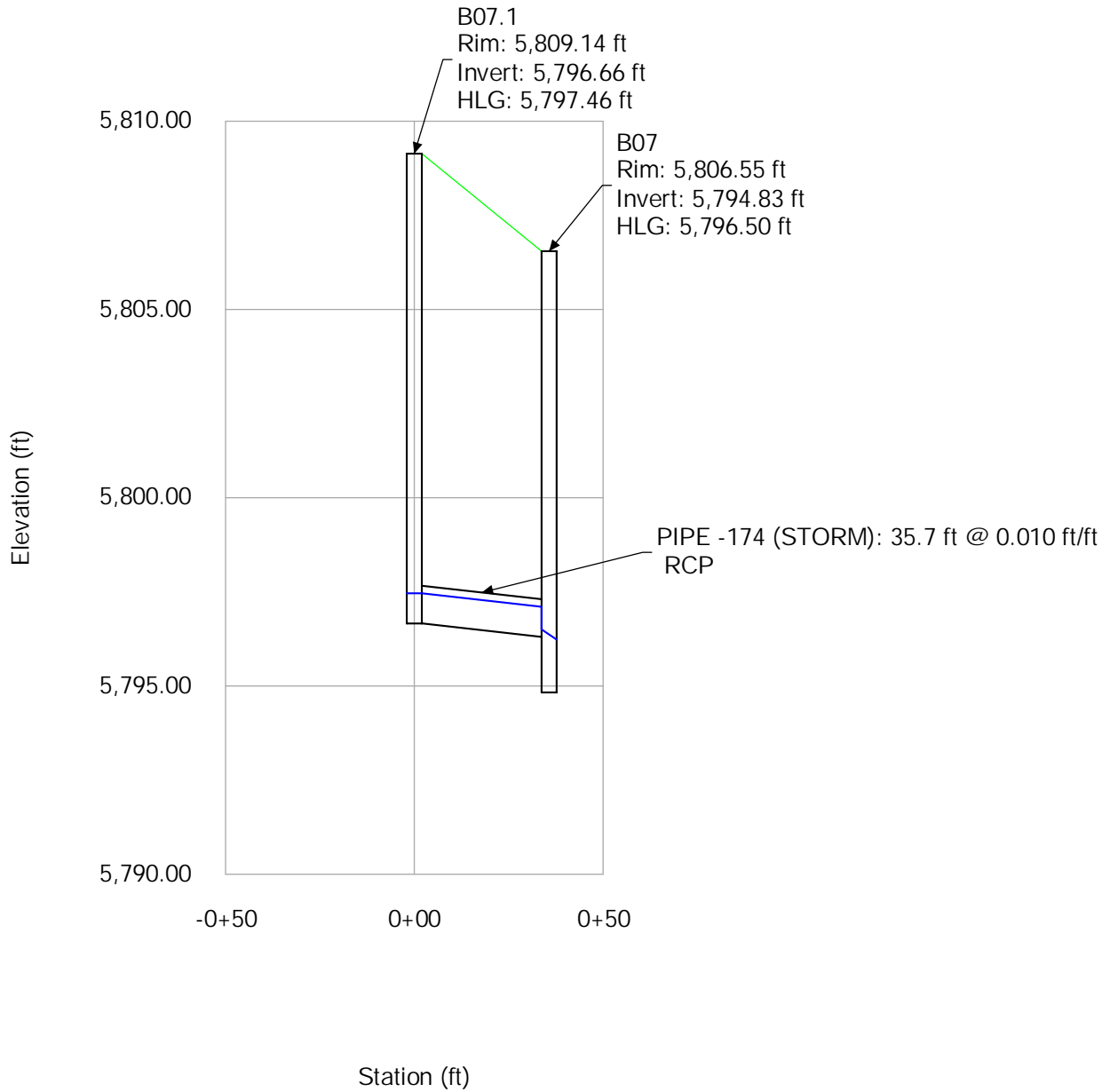

Profile Report

Profile Lateral B.2 (100-Year)

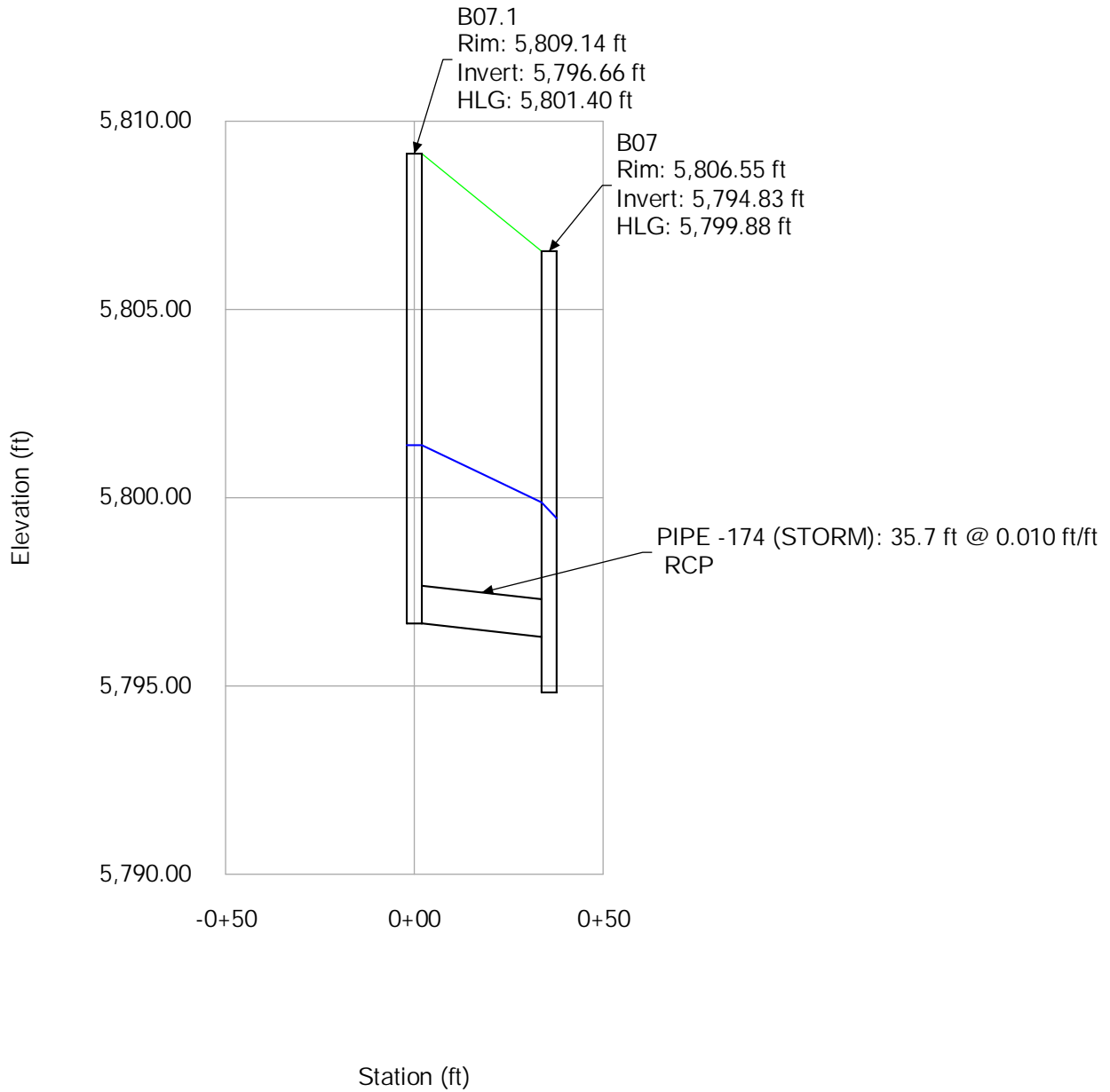

Profile Report

Profile Lateral B.3 (5-Year)

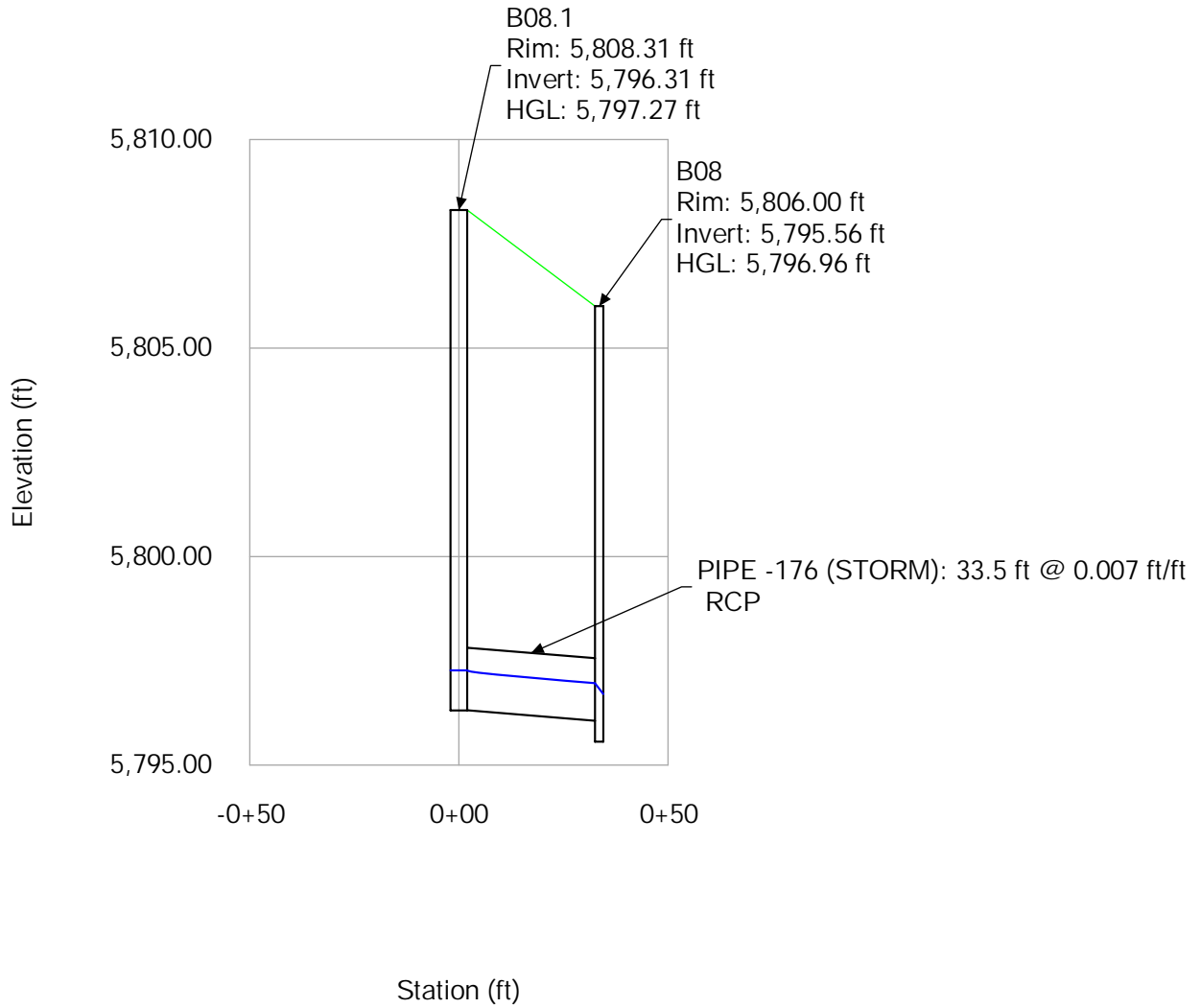

Profile Report

Profile Lateral B.3 (100-Year)

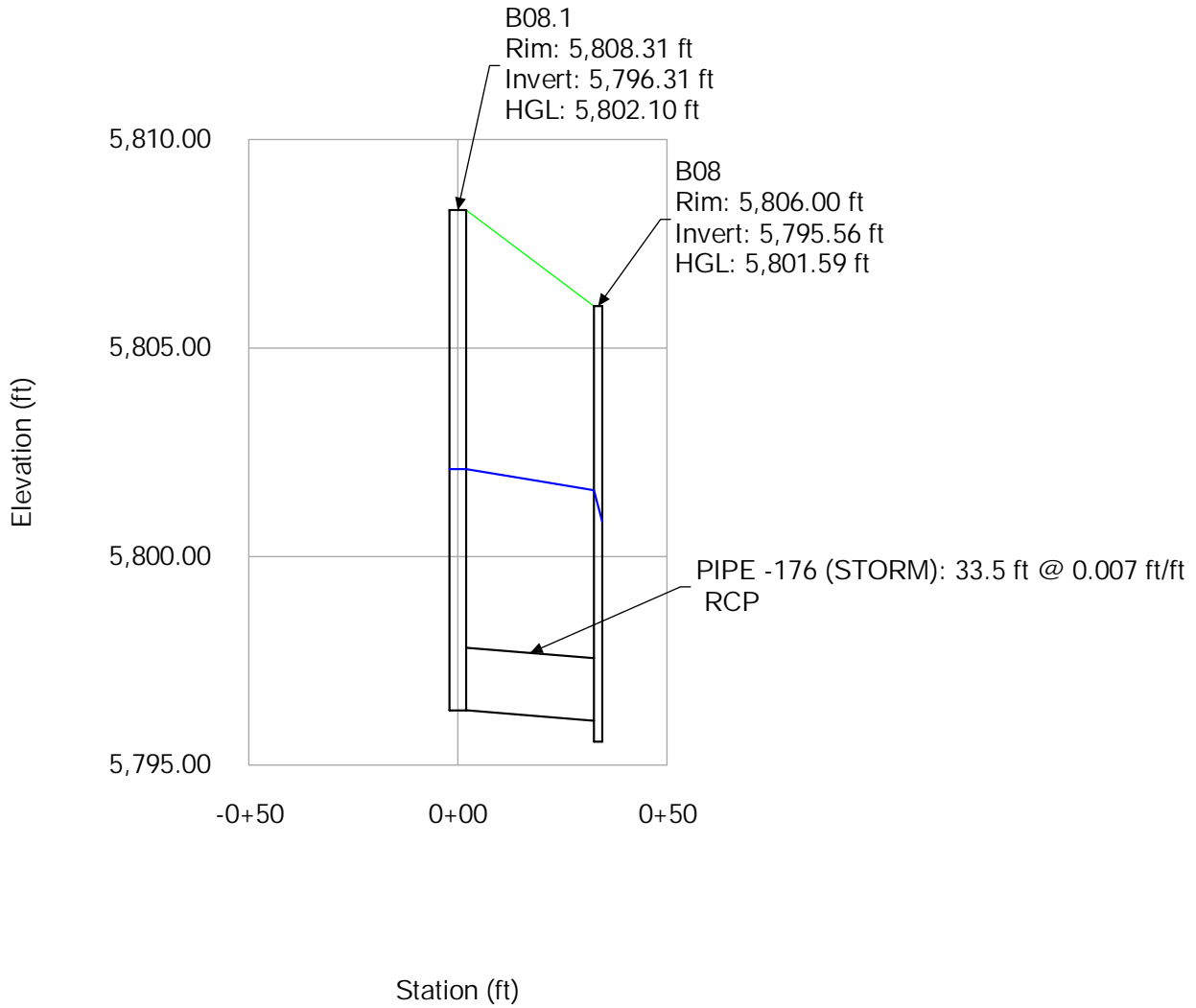

Profile Report
Profile Lateral B.4 (5-Year)

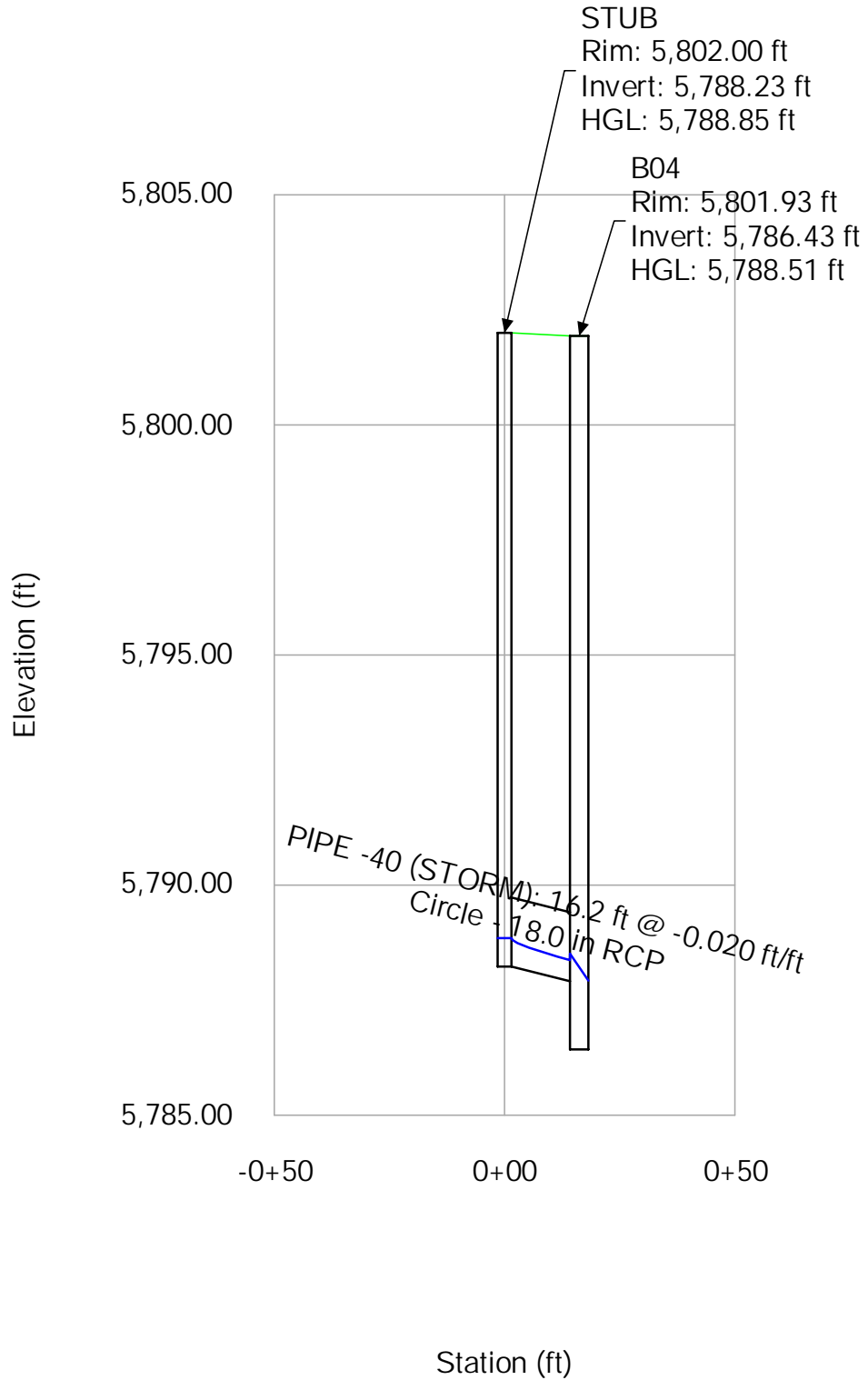

Profile Report
Profile Lateral B.4 (100-Year)

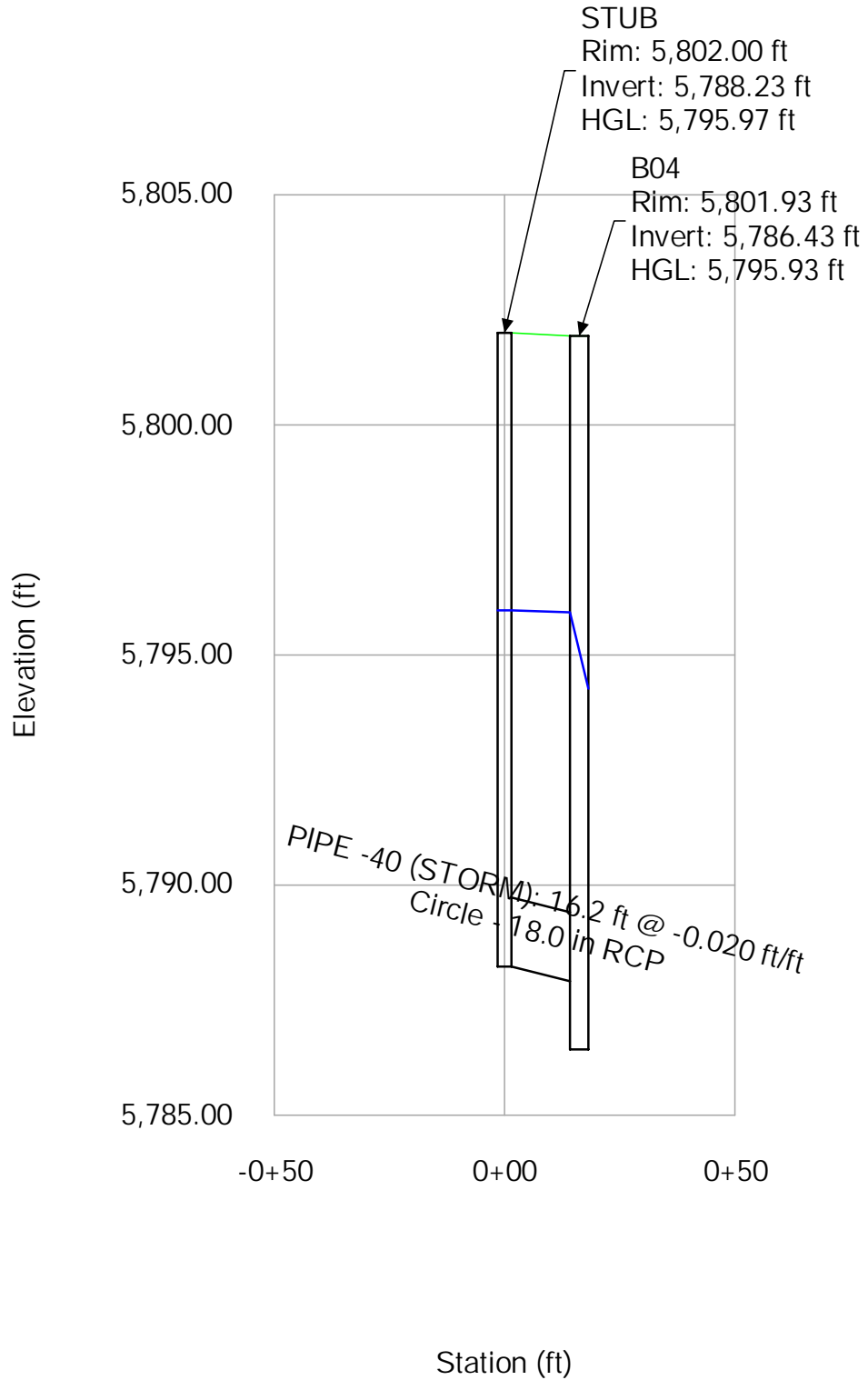

Profile Report

Profile Main C (5-Year)

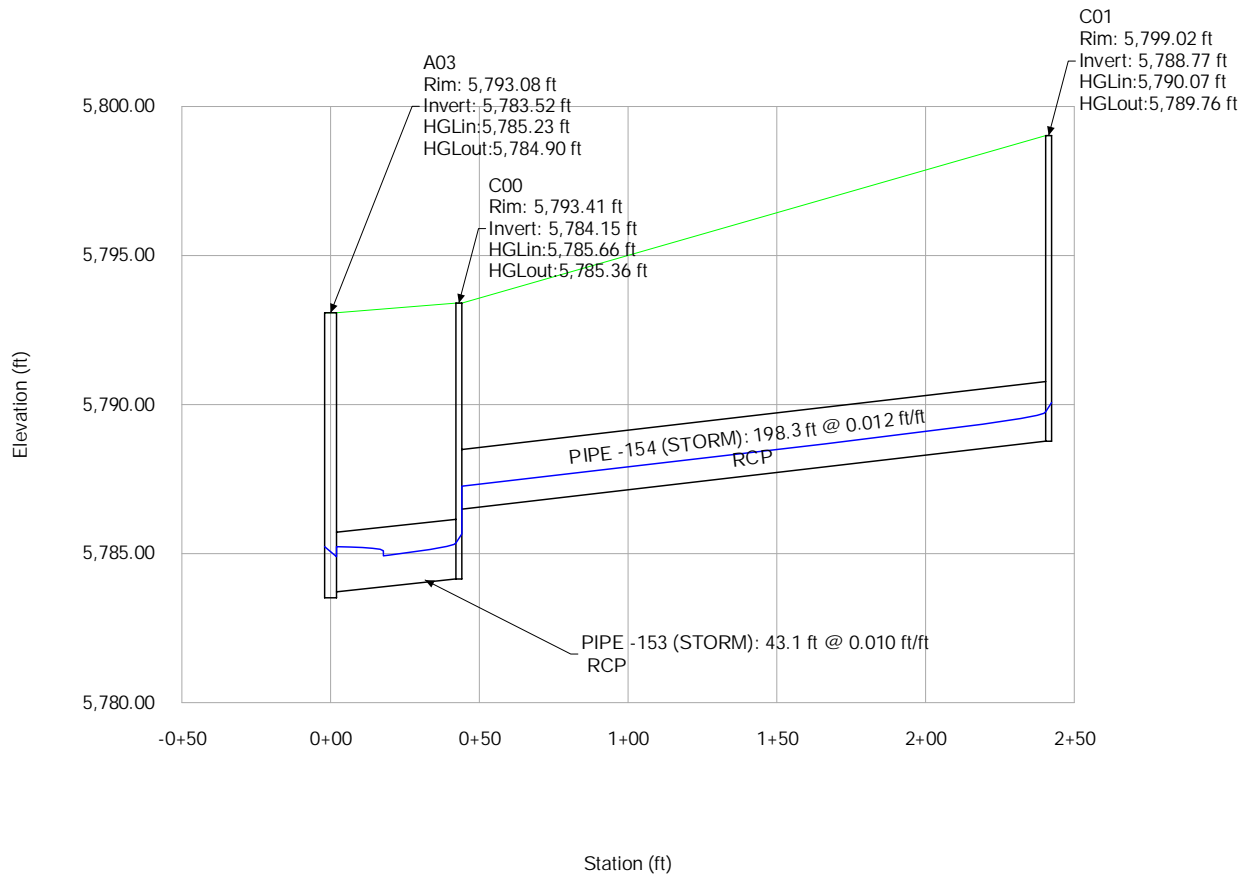

Profile Report

Profile Main C (100-Year)

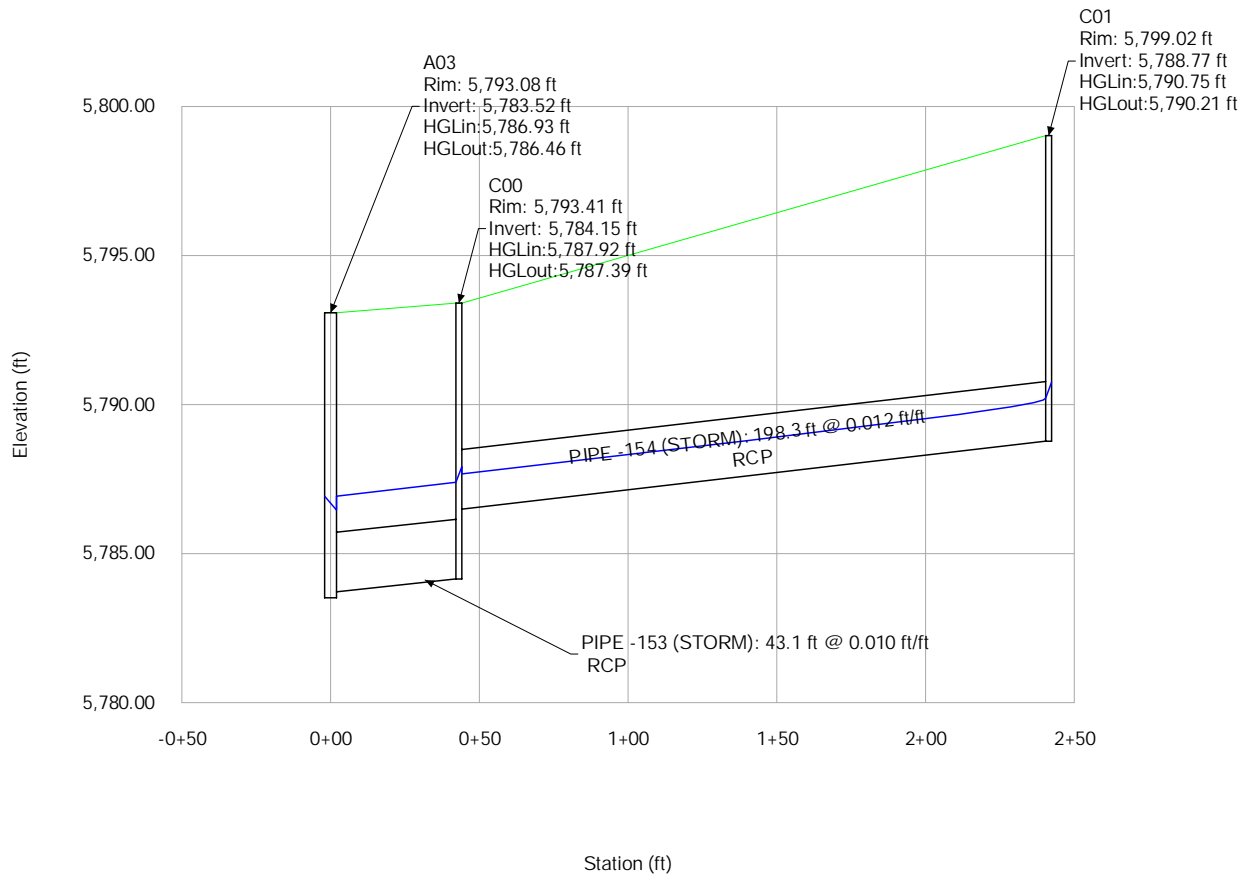

Profile Report

Profile Lateral C.1 (5-Year)

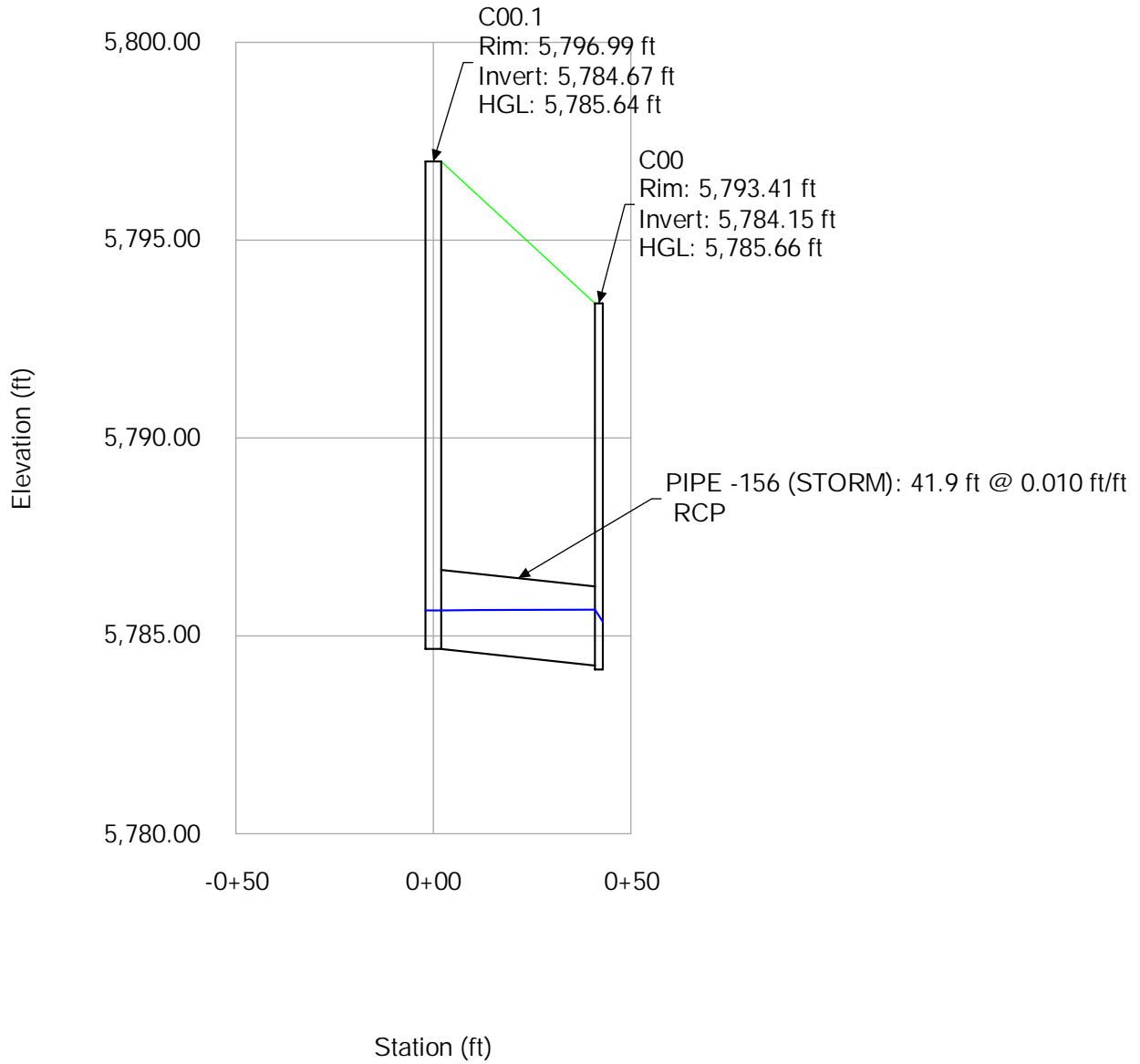

Profile Report

Profile Lateral C.1 (100-Year)

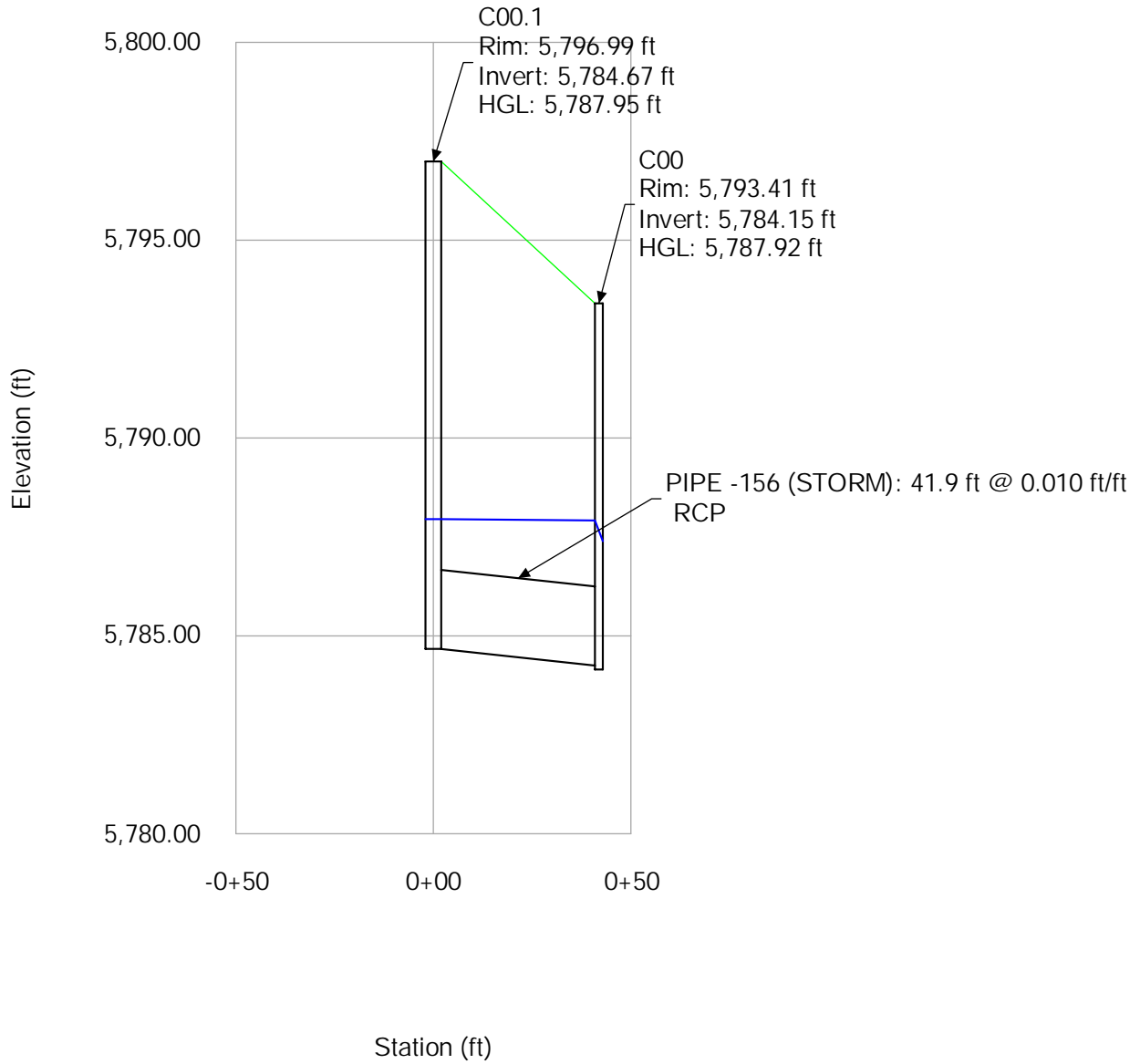

Profile Report

Profile Lateral C.2 (5-Year)

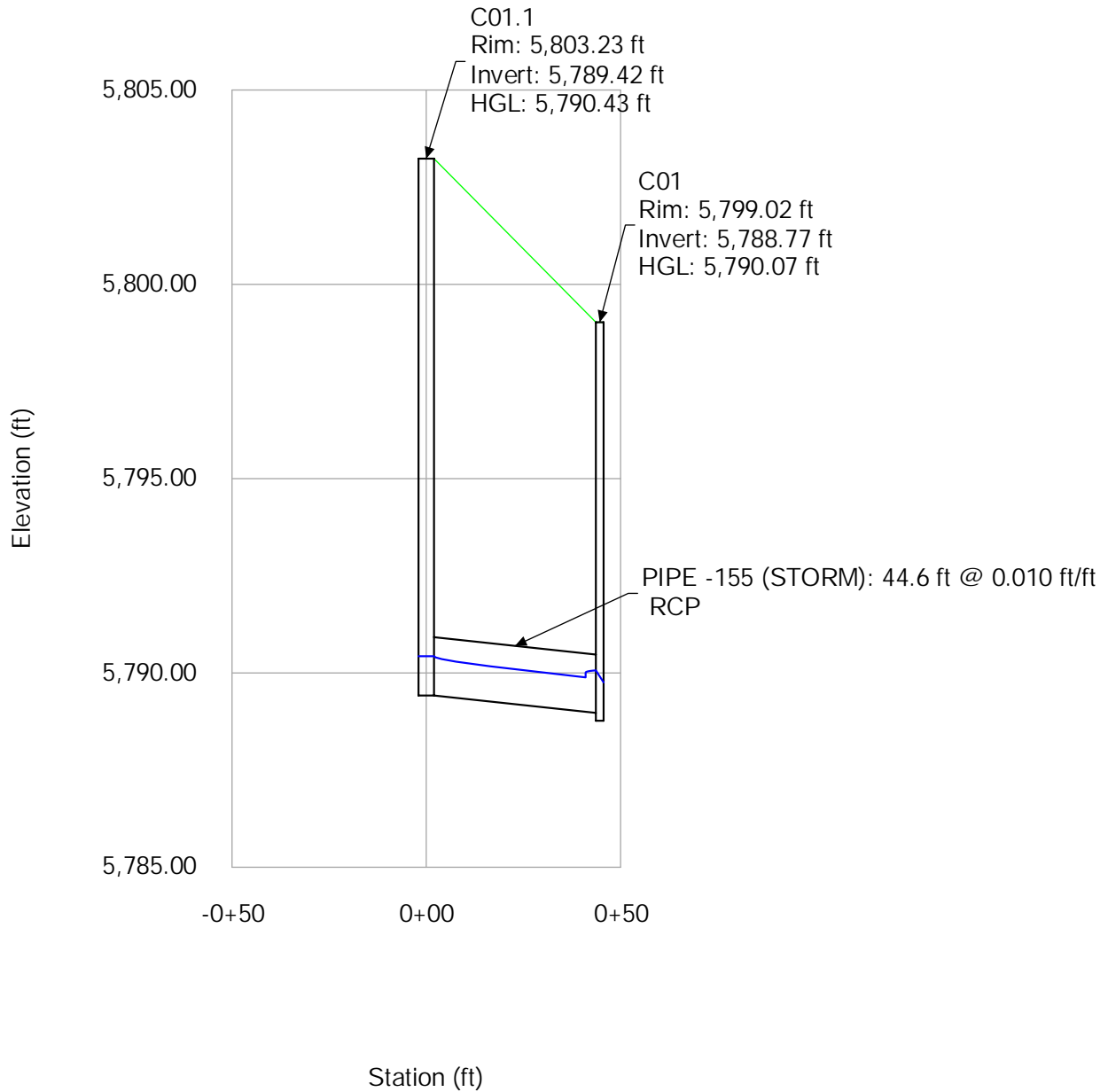

Profile Report

Profile Lateral C.2 (100-Year)

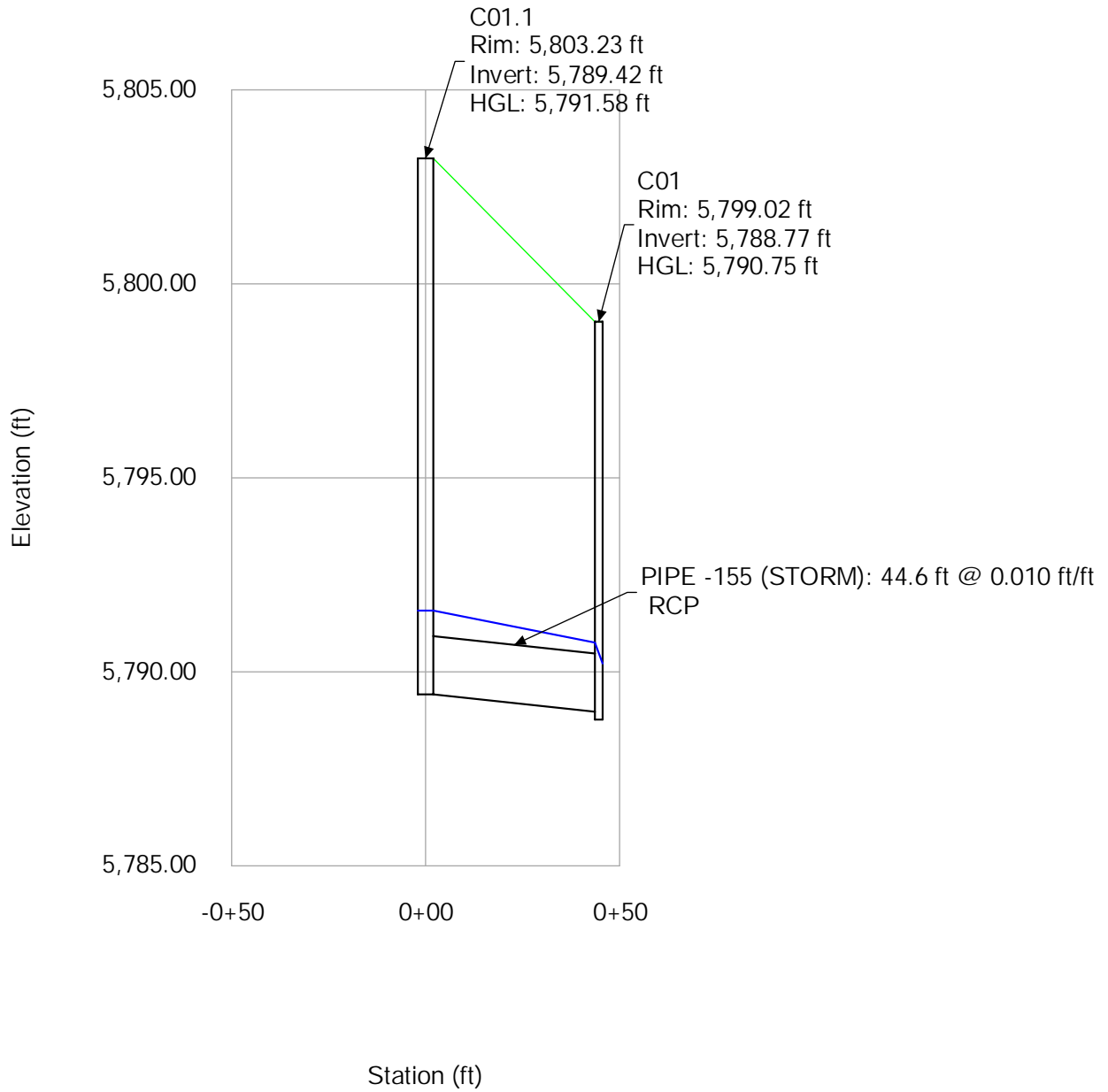

Profile Report

Profile Lateral D.1 (5-Year)

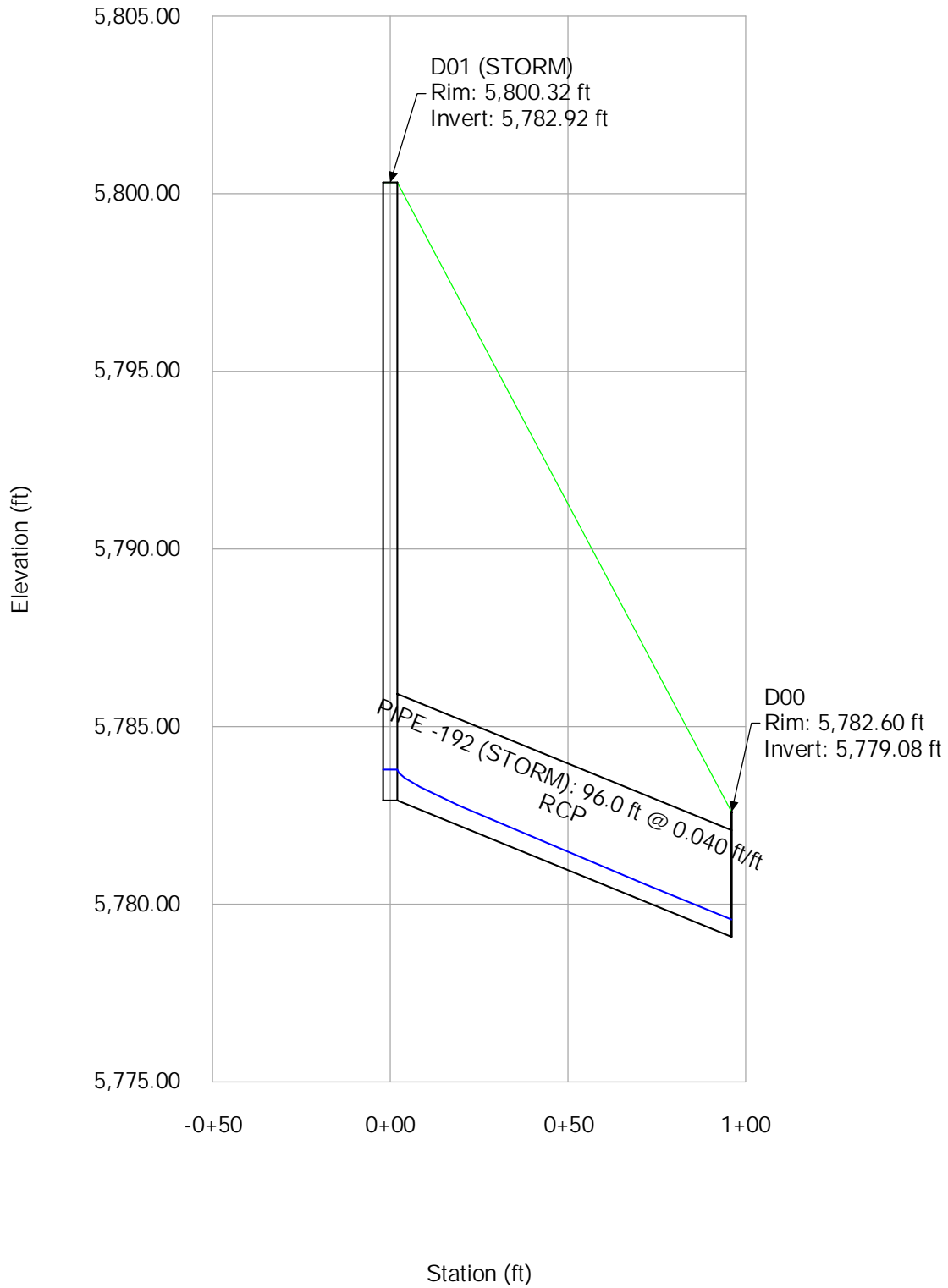

Profile Report

Profile Lateral D.1 (100-Year)

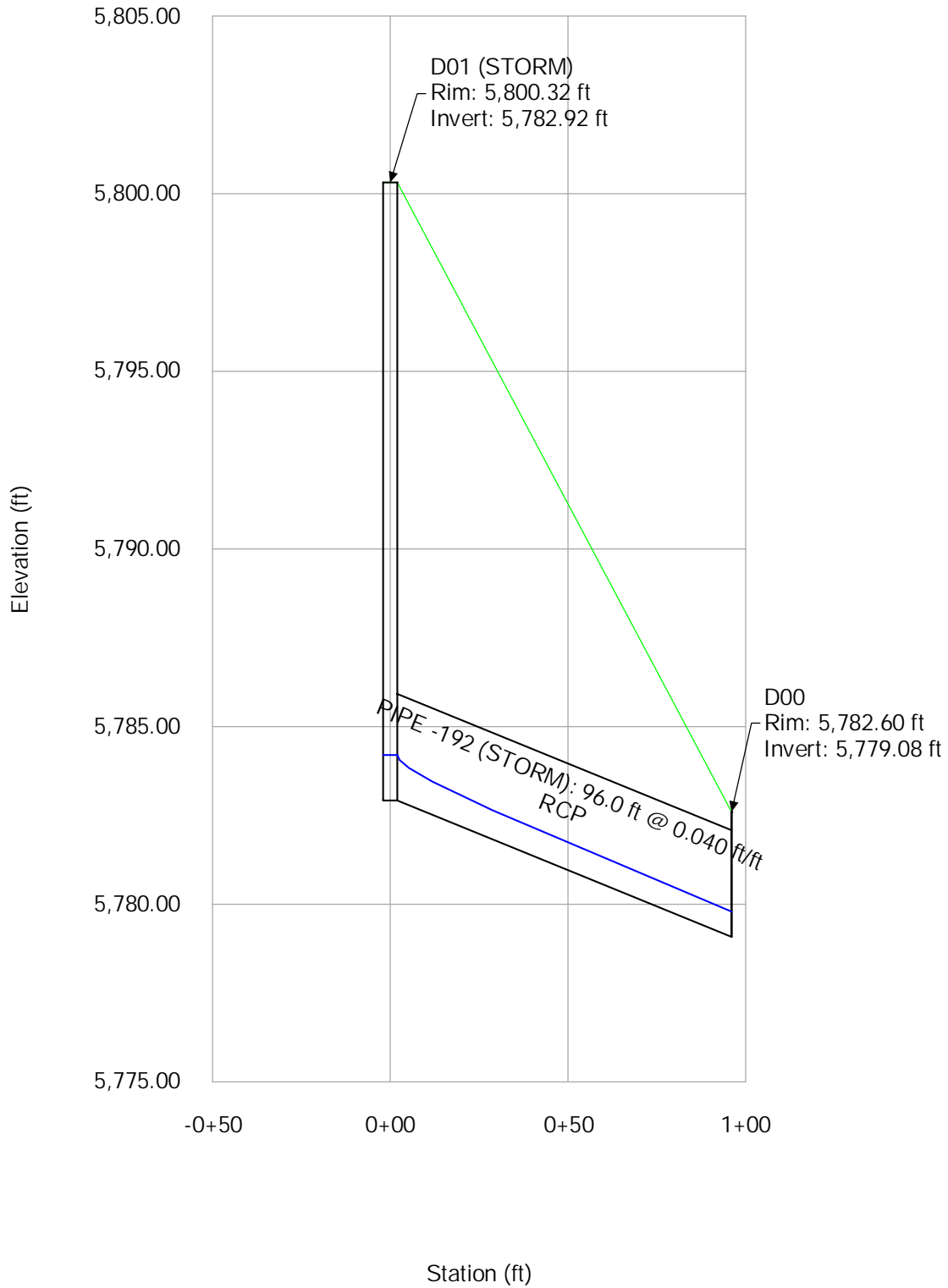

APPENDIX E - REFERENCES

TOWN OF PARKER

AUG 13 2004

PLANNING DEPT.

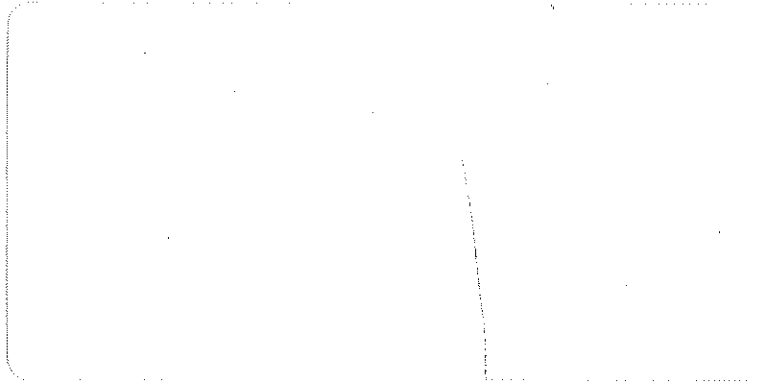

**Final Drainage Report
Parker Auto Plaza
Town of Parker
Douglas County, Colorado**

Prepared for:

Parker Auto Plaza, LLLP
% Concepts West Architecture
202 East Cheyenne Mountain Blvd.
Suite Q
Colorado Springs, Colorado 80906

Prepared by:

Kiowa Engineering Corporation
1604 South 21st Street
Colorado Springs, Colorado 80904

Kiowa Project No. 00056

July 12, 2004

ENGINEER'S STATEMENT:

This report for the final design of the Parker Auto Plaza development was prepared by me or under my direct supervision in accordance with the provisions of the Town of Parker Storm Drainage and Environmental Criteria Manual. I understand that the Town of Parker and its designated town authority do not and will not assume liability for drainage facilities designed by others.

Kiowa Engineering Corporation, 7175 W. Jefferson Ave Suite 3400, Lakewood, CO 80235

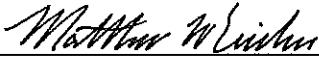

Registered Professional Engineer
State of Colorado # 36713
(For and on behalf of Kiowa Engineering Corp.)

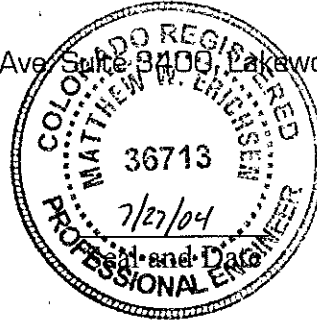

Table of Contents

Engineer's Statement	i
Table of Contents	ii
General Location and Description	1
Drainage Basins and Sub-Basins	
Major Basin Description	1
Site Sub-Basin Description	3
Floodplains.....	3
Drainage Design Criteria	
Regulations.....	4
Development Criteria Reference and Constraints	5
Hydrologic Criteria	5
Hydraulic Criteria.....	5
Drainage Facility Details	
General Concept.....	6
Drainage Basin and Storm Sewer System Description	6
Detention Basin Facility Description	7
Baldwin Gulch Drainageway Facility Description	8
Sculpted Concrete Drop – Cutoff Wall Analysis	9
Environmental Protection Criteria	9
Conclusions	10
References and Software	11
Appendix	12
See Appendix for Table of Contents	
List of Figures (Additional figures and tables are included in the Appendix)	
Figure 3	Vicinity Map..... 2
Figure 7	Future Major Watershed Boundaries and Reach Delineations..... Appendix
Figure 8	Flood Insurance Rate Map..... Appendix
Figure 9	Soil Survey Map..... Appendix

General Location and Description

This report addresses the drainage impacts related to the Parker Auto Plaza development. The development will include construction of automobile sales facilities, an automobile body shop and future commercial site development. The property is located in the northwest quarter and southwest quarter of Section 10, Township 6 South, Range 66 West of the Sixth Principal Meridian. The property lies northwest of the intersection of Parker Road and Lincoln Avenue. It is bounded on the north by Pine Lane, on the east by Parker Road, Dransfeldt Road and MacLachlan Subdivision Nos. 1 & 2, on the south by Lincoln Avenue and on the west by the proposed extension alignment of Twenty Mile Road. The proposed Parker Auto Plaza site includes approximately 52.7 acres. A vicinity map of the area is included as Figure 3.

The site is covered by native vegetation, including weeds, sagebrush and a few large and smaller deciduous trees. Baldwin Gulch runs through the property from an existing box culvert under Parker Road to the proposed extension alignment of Twenty Mile Road.

Approximately 31.6 acres of the site will be utilized for the proposed commercial development sites described above. The 8.1 acres that surrounds Baldwin Gulch and the 100-year flood plain will be designated open space. This area will remain undeveloped except for a proposed trail and trailhead area and for channel improvements recommended in the *Baldwin Gulch Outfall Systems Planning Study* prepared by the Urban Drainage and Flood Control District.

Drainage Basins and Sub-Basins

Major Basin Description

The site was part of the MacLachlan Property (of which Filing Nos. 1 & 2 are currently developed). As a result of the review of the final drainage report for the MacLachlan Subdivision No. 1 (S.A. Miro, Inc., March 1994), and the *Newlin and Baldwin Gulches and Basin 4600-09 Outfall Systems Study Preliminary Design Report* (Kiowa Engineering Corporation, December 1994), it is apparent that the site lies within a portion of two major historic basins; Basin 4600-09 and Baldwin Gulch. Basin 4600-09 drains directly into Cherry Creek west of the site. A copy of the Future Major Watershed Boundaries and Reach Delineations, Baldwin Gulch basin 4600-09 is included in the Appendix of this report as Figure 7. The outfall for Baldwin Gulch into Cherry Creek is located approximately one-quarter mile west of the proposed extension of Twenty Mile Road. In the current condition it appears that a portion of the flows from the Basin 4600-09 section of the site are being diverted into Baldwin Gulch by the existing road in the Twenty Mile Road R.O.W. Existing drainage basins are shown on Figure 1 that is located in the map pocket at the end of this report.

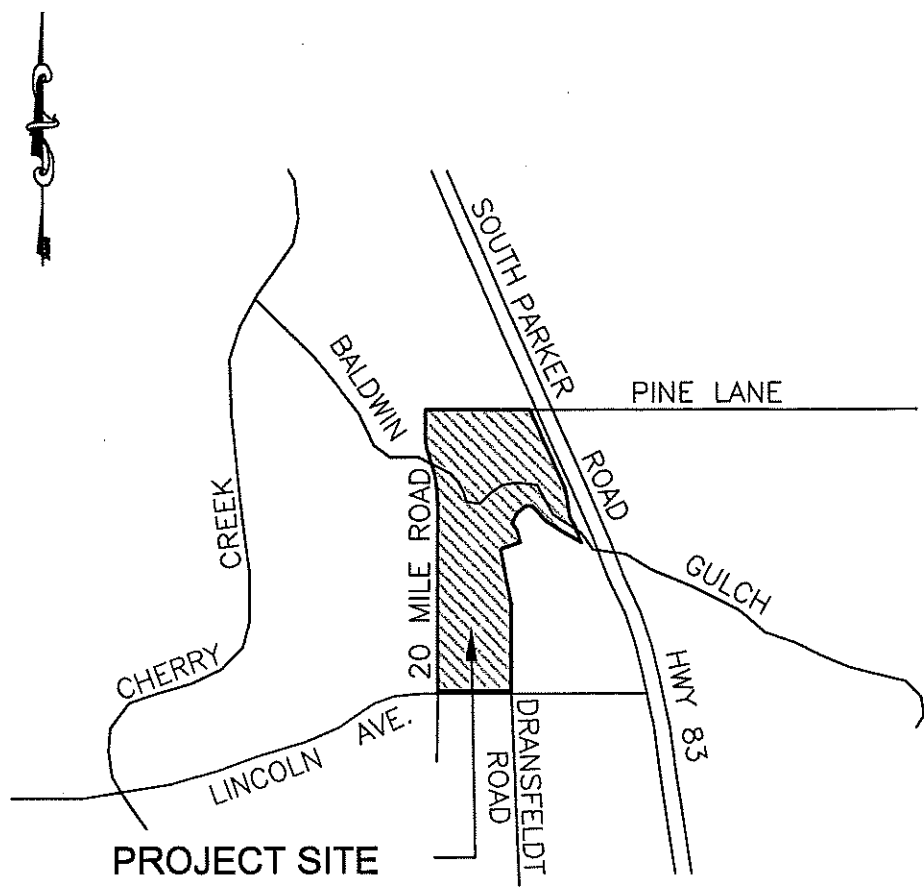

FIGURE 3
VICINITY MAP
PARKER AUTO PLAZA

Site Sub-Basin Description

Most of the flows from the developed lots within the MacLachlan subdivision drain to onsite detention basins. These detention basins in turn outfall directly into Baldwin Gulch and will remain in this condition. A small portion of Ponderosa Drive discharges onto the site in the current condition, and will be conveyed across the site by curb and gutter as Dransfeldt Road will be extended to Twenty Mile Road during the development of the site. Channel improvements will be made to Baldwin Gulch as part of the site development. The channel improvements noted in the *Newlin and Baldwin Gulches and Basin 4600-09 Outfall Systems Study (OSP) Preliminary Design Report* were reviewed during the Preliminary Drainage Report (PDR) for the site. The following modifications have been made to the channel improvements outlined in the *OSP* as part of the *PDR* review by UDFCD and the Town of Parker. Sculpted concrete drop structures have been substituted for the check structures shown in the *OSP*. The sculpted drop structures have replaced the checks so that the channel can be constructed to the ultimate longitudinal slope anticipated for sandy soils instead of allowing the channel to degrade over time with check structures as recommended in the *OSP*. This will minimize the amount of sediment that could be conveyed to Cherry Creek resulting from the degradation of the invert along this portion of Baldwin Gulch. The longitudinal slope of the channel was also modified from 0.94% to 0.6% to reduce the flow velocities in the channel. The proposed improvements to Baldwin Gulch are shown on the Drainage Plan, Figure 2. No further onsite drainage improvements are needed to convey flows from MacLachlan Subdivisions through the site.

The development of the site will not change the drainage patterns significantly onsite. However the increase in runoff that accompanies the development of the site will require the construction of two detention basins. The detention basins are located east of the future alignment of Twenty Mile Road to regulate discharge from the site into Baldwin Gulch. A storm sewer system will be required on the parcels south of Baldwin Gulch in order to convey site runoff from drainage basins 1B-12B into Detention Basin B south of Baldwin Gulch. A storm sewer system will also be required to convey flows from drainage basins 1A-5A to Detention Basin A (see Figure 2).

The existing and proposed grading precludes any treatment or detention of the runoff from Twenty Mile Road basins 3C and 4C and Pine Lane basins 1D and 2D. The Twenty Mile Road basins will be released to their historic Baldwin Gulch outfall location. The drainage basins along Pine Lane will be released to their historic outfall location westerly along the south edge of Pine Lane, eventually reaching Baldwin Gulch. The drainage improvements associated with Pine Lane will be completed as part of the Pine Lane extension project by Douglas County.

Floodplains

The Baldwin Gulch existing 100-year flood plain is shown on Figure 1 located in a map pocket at the end of this report. The 100-year flood plain boundary is based in part on the *1977 Flood Hazard Delineation (FHAD) Report* for Baldwin Gulch. The flood plain boundary was confirmed using Panel Number 080310 0070 D of the FEMA Flood Insurance Rate Map for

Douglas County, shown in Figure 8 which is located in the Appendix of this report. The development of this site will include channel improvements to Baldwin Gulch. These improvements, along with Detention Basin A south of Baldwin Gulch, east of the proposed Twenty Mile Road extension alignment will be the only grading that will occur within the 100-year floodplain. The construction of the channel improvements and attendant grading along the major drainageway will alter the 100-year floodway and floodplain through the site east of the proposed Twenty Mile Road extension. The proposed 100-year floodplain resulting from the proposed channel improvements is shown on Figure 2. A conditional Letter of Map Revision (CLOMR) will be required for this project. The submittal of a CLOMR to FEMA will commence once the design of the Baldwin Gulch improvements are generally approved and accepted by the Town of Parker and the Urban Drainage and Flood Control District.

Drainage Design Criteria

Regulations

In accordance with the Town of Parker's Floodplain ordinance, no temporary or permanent structures designed for human habitation will be placed in the floodplain. There will be a multi-use trail proposed along the Baldwin Gulch drainageway. The area adjacent to the low flow channel and on overbanks will be revegetated with native grasses, trees, and shrubs.

The development of this site will include improvements to the Baldwin Gulch channel, as stated above. These improvements include four sculpted concrete drop structures as well as grading the channel to conform to the recommended channel section and reinforcing the channel as necessary to minimize the adverse affects of erosion along Baldwin Gulch and the lands adjacent to it. A riprap lined low flow channel of 5-year capacity with a benched channel section above the low flow area is proposed. The total 100-year flooding depth along the channel through the site ranges from four to six-feet. A multi-use trail will follow the channel along the north bench of the drainageway, generally located above the 100-year floodplain. This trail will cross beneath proposed Twenty Mile Road in a three-sided box culvert. The upstream portion of the multi-use trail will cross under Parker Road through the north bay of the existing twin box culvert. The trail will loop up to Parker Road on the north side. The trail will continue south along Parker Road to the existing multi-use trail located on the south side of Baldwin Gulch and east of Parker Road. The plan and profile design for Baldwin Gulch has been included in a map pocket at the end of this report.

The proposed channel improvements will alter the existing channel section for the entire length of Baldwin Gulch within the project site. As a result of field meetings with the U. S. Army Corps of Engineers it was determined that a 404 Permit will not be required for the proposed channel improvements. It was determined that the portion of Baldwin Gulch through the site is not considered as jurisdictional waters of the United States.

Development Criteria Reference and Constraints

The Final Drainage Report for MacLachlan Subdivision No. 1 includes portions of this site in its analysis of historic drainage basins, however, drainage reports including developed conditions for this site could not be found. This drainage study generally agrees with the Final Drainage Report for MacLachlan Subdivision No. 1 concerning the historic drainage patterns for the site.

The Final Drainage Report for MacLachlan Subdivision No. 1 describes the developed flows of the neighboring subdivision. This study indicates that all flows aside from three small basins will be routed to a detention basin in MacLachlan Subdivision No. 1 and discharged directly into Baldwin Gulch. Two of the three small basins currently discharge onto the project site. When Dransfeldt Road is extended to Twenty Mile Road as a part of the development of this site, runoff from the offsite sub-basins currently discharging will be conveyed by curb and gutter to the storm sewer system in Dransfeldt Road and Twenty Mile Road and from there to Detention Basin B.

Hydrologic Criteria

Basin runoff was calculated using the Rational Method. Hydrology for Baldwin Gulch was obtained from the Newlin and Baldwin Gulches Outfall Systems Planning Study. The 5-year and 100-year peak discharges for the segment of Baldwin Gulch adjacent to the site are 260 cubic feet per second and 2,100 cubic feet per second, respectively.

Hydraulic Criteria

The drainage systems and street capacities for this site have been designed to accommodate the 5-year initial storm event and the 100-year major storm event as specified in the Town of Parker, Colorado, *Storm Drainage and Environmental Criteria Manual (SDECM)*. The hydraulic capacities of the curb inlets were determined using the UDINLET computer model developed by the University of Colorado at Denver. The initial storm event water spread was used to help determine the inlet locations in the site. Table 2.4 from the *SDECM* was used to determine the maximum allowable water spread for the initial storm runoff and has been included in the Appendix. An Inlet Capacity Summary spreadsheet is included in the Appendix, showing the inlet capacities and the minor storm water spread in tabular form. Colorado Department of Transportation (CDOT) Type R curb inlets will be used throughout the site. City of Denver Standard No. 16 Open Throat Inlets will be used in areas where there is insufficient area behind the curb for a curb-opening inlet.

Detention basins for this site have been designed to conform to the 10-year and 100-year regulated release rates per the aforementioned manual. Detention basins were sized and discharge rates determined using the UDFCD Detention Formulas. The supporting calculations associated with the sizing of hydraulic facilities for this development are included in the Appendix of this report.

Drainage Facility Details

General Concept

In the current condition, drainage from the proposed site flows into Baldwin Gulch. Calculations for the analysis of existing drainage basins are presented in the appendix at the end of this report. The existing Drainage Plan, including drainage basins are shown in Figure 1. The proposed development seeks to preserve the existing drainage patterns with the exception of routing flows through detention basins prior to discharging into Baldwin Gulch in order to limit flows from the developed site to acceptable levels. Calculations for the analysis of developed basins for this site, as well as calculations for the design of the detention basins and their tributary storm water conveyances are presented in the appendix of this report. The configuration of proposed basins and their related drainage facilities are presented in Figure 2. Offsite runoff impacting the site is minimal and will be conveyed across the site with the extension of Dransfeldt Road to be handled by the drainage facilities discharging to Detention Basin B.

Drainage Basin and Storm Sewer System Description

Runoff from Basin 1A will sheet-flow westerly through a parking lot area to a 10-foot sump curb inlet (Inlet 1). The flows captured by the inlet will be routed to Inlet 2. Drainage from Basin 2A will sheet-flow westerly through a parking lot area to a 15-foot curb inlet in sump condition. The flows will combine with flows from Inlet 1 and be carried by a storm sewer to Detention Basin A. Flows generated from Basin 3A will sheet-flow westerly through a parking lot area to a 10-foot sump curb inlet. A storm sewer will route the flows to Detention Basin A. Runoff generated from Basin 4A will sheet-flow southwesterly through a parking lot area to a 10-foot sump curb inlet. The flows will be routed to Detention Basin A by a storm sewer.

Runoff from Basin 1B will be carried northerly by curb and gutter along the western side of Twenty Mile Road. The runoff will be collected by a 15-foot on grade curb inlet at Dransfeldt Road. Runoff generated within Basin 2B will be carried northerly by curb and gutter along on the eastern side of Twenty Mile Road. The runoff will be collected by a 10-foot on grade curb inlet at Inlet 11. Drainage developed from Basin 3B will sheet-flow westerly through a parking lot area to be collected by a 15-foot sump curb inlet near Twenty Mile Road. The flow will then be carried by a 24-inch RCP to join with flows at Inlet 20. Runoff generated within Basin 4B will sheet-flow west through a parking lot area and will be collected by a 10-foot sump curb inlet. The flow will then be carried to Inlet 20 by a storm sewer. Drainage from Basin 5B will sheet-flow northwest through a parking lot area and will be collected by a 10-foot sump curb inlet. The flow will be routed to Inlet 19 through a storm sewer. Drainage from Basin 6B will sheet-flow northwest through a parking lot area and will be collected by a 5-foot sump curb inlet. The flow will be routed to Detention Basin B through a storm sewer. Drainage from Basin 7B will be carried northwest by the Dransfeldt Road curb and gutter to 15-foot curb inlets on grade at the intersection of Twenty Mile Road. A storm sewer will route the flows into the storm

sewer system along Twenty Mile Road. Runoff generated from Basin 8B will sheet-flow directly to Detention Basin B. Runoff generated from Basin 9B will sheet-flow westerly to a 15-foot sump curb inlet. At this point the runoff will combine with the flows in the 36-inch RCP storm sewer located along the east side of Twenty Mile Road (Twenty Mile Storm Sewer). The storm sewer will continue north to a manhole to the north of Dransfeldt Road. The Twenty Mile Storm Sewer will bend at this manhole and be directed into Detention Basin B. The runoff generated by Basin 10B will be carried along the gutter of the private drive extending into the commercial development area. The flows will continue along the east curb and gutter of Twenty Mile Road to a 20-foot inlet (Inlet 18) on grade at the intersection with Dransfeldt Road. The runoff captured by Inlet 20 will be directed into the Twenty Mile Storm Sewer. Runoff generated within Basin 11B will sheet-flow westerly through a parking lot area and will be collected by a 10-foot sump curb inlet near Twenty Mile Road. The flows will be routed into the Twenty Mile Storm Sewer. Runoff generated within Basin 12B will sheet-flow westerly through a parking lot area and will be collected by a 10-foot sump curb inlet near Twenty Mile Road.

Flows developed within Basin 1C will be carried southeasterly by a grass-lined swale to enter Baldwin Gulch. Runoff from Basin 2C will sheet-flow directly to Baldwin Gulch. Drainage Basins 3C-5C are located along a superelevated portion of Twenty Mile Road. Inlets have been located along this section of Twenty Mile Road to minimize the amount of flows crossing the street at points of superelevation. Drainage generated from Basin 3C will sheet-flow onto the west median curb line of Twenty Mile Road. An inlet will be placed along the west curb of Twenty Mile Road to capture the flows. The flows will be conveyed to Baldwin Gulch through a storm sewer. Flows from Basin 4C will be carried along the west curb and gutter of Twenty Mile Road to Inlet 27A. The flows will be routed by a storm sewer into Inlet 27. Flows from Basin 5C will flow onto the east curb and gutter of Twenty Mile Road to Inlet 25 at the low point. Flows from Basin 6C will flow along the east median curb and gutter of Twenty Mile Road to Inlet 26 at the low point. A storm sewer will route the flows to Inlet 26 and Baldwin Gulch. Runoff generated from Basins 1D and 2D will be handled as part of the Pine Lane Improvements. Runoff generated from Basin 1D is carried northerly along the west curb and gutter onto Pine Lane. The flows from Basin 2D will be captured by an inlet and conveyed to the Pine Lane storm sewer system.

Detention Basin Facility Description

The required detention volumes for Detention Basin A are 2.06 acre-feet for the 10-year event and 2.97 acre-feet for the 100-year event, which includes the WQCV. Calculations for this detention basin are located in the Appendix of this report. To control the release of flows and allow for pollutant removal, the detention basin is designed as an Extended Detention Basin Sedimentation Facility, as shown in Figure EDB-1 in Volume 3 of the Urban Storm Drainage Criteria Manual, found in the Appendix of this report. The design will include a forebay, trickle channel and emergency spillway. Modifications to the Figure EDB-1 design were made per the request of the Town of Parker. The modifications include the elimination of the micropool and

APPENDIX A
Hydrologic Calculations

Parker Auto Plaza
Time of Concentration (Existing)

Basin	Contributing Basins	Slope		Length		C _s	Velocity		T _c		T _c
		O'land	Travel	O'land	Travel		O'land	Travel	O'land	Travel	
A		6.1 %	0.9 %	150 lf	1125 lf	0.01	0.2 ft/sec	0.5 ft/sec	788 sec.	2272 sec.	51.0 min.
B		2.4 %	2.5 %	150 lf	1105 lf	0.01	0.1 ft/sec	1.0 ft/sec	1077 sec.	1163 sec.	37.3 min.
C		1.9 %	2.4 %	150 lf	1659 lf	0.01	0.1 ft/sec	0.9 ft/sec	1158 sec.	1880 sec.	50.6 min.
D		2.5 %	3.4 %	150 lf	900 lf	0.01	0.1 ft/sec	1.1 ft/sec	1067 sec.	842 sec.	31.8 min.
E		1.5 %	3.9 %	150 lf	814 lf	0.01	0.1 ft/sec	0.8 ft/sec	1268 sec.	1072 sec.	39.0 min.

Equations:

$$\text{Time of Concentration (Overland)} = 1.8(1.1 - C_s)L^{0.5} S^{-0.333}$$

C_s = Runoff coefficient for five-year flow

L = Length of overland flow in feet (Length must be less than 1,000 feet for undeveloped area before entering a channel)

S = Slope of flow path in percent

**Parker Auto Plaza
Basin Runoff Calculation (Existing)**

Basin	Contributing Basins	Area		C ₁₀	C ₁₀₀	Time of Concentration	Rainfall Intensity		Runoff	
							i ₁₀	i ₁₀₀	Q ₁₀	Q ₁₀₀
A		519,090 sf	11.92 ac	0.05	0.20	51.0 min.	1.8 in/hr	2.9 in/hr	1.1 cfs	7.0 cfs
B		657,300 sf	15.09 ac	0.05	0.20	37.3 min.	2.3 in/hr	3.6 in/hr	1.7 cfs	10.8 cfs
C		512,500 sf	11.77 ac	0.05	0.20	50.6 min.	1.9 in/hr	2.9 in/hr	1.1 cfs	6.9 cfs
D		256,610 sf	5.89 ac	0.05	0.20	31.8 min.	2.5 in/hr	3.9 in/hr	0.7 cfs	4.6 cfs
E		354,940 sf	8.15 ac	0.05	0.20	39.0 min.	2.2 in/hr	3.5 in/hr	0.9 cfs	5.7 cfs

Equations:

$$I = (28.5P) / (10 + t_c)^{0.786}$$

P = One-hour point rainfall depth (in.) P(5yr)=1.39in. P(10yr)=1.64in. P(100yr)=2.60in.

i₅, i₁₀, i₁₀₀ = Average 5, 10 and 100-year Rainfall Intensity in inches per hour (Fig 5.1, Town of Parker Storm Drainage and Environmental Criteria Manual)

$$Q = CiA$$

Q = Peak Runoff Rate, in cubic feet per second (cfs)

C = Runoff coefficient representing a ration of peak runoff rate to average rainfall intensity for a duration equal to the runoff time of concentration.

i = average rainfall intensity in inches per hour

A = Drainage area in acres

Parker Auto Plaza
Runoff Coefficient Calculation (Developed)

Design Point	Basin	Area	% Area	C ₅	C ₁₀₀	C ₅	C ₁₀₀
DP 1	1A-4A	13.96 ac	90.31 %	0.81	0.88	0.73	0.79
	5A	1.50 ac	9.69 %	0.14	0.40	0.01	0.04
		15.45 ac	100.0 %			0.75	0.83

Design Point	Basin	Area	% Area	C ₅	C ₁₀₀	C ₅	C ₁₀₀
DP 2	1B,3B-7B,9B-13B	16.83 ac	85.84 %	0.81	0.88	0.70	0.76
	2B	0.94 ac	4.78 %	0.54	0.66	0.03	0.03
	8B	1.84 ac	9.38 %	0.14	0.40	0.01	0.04
		19.61 ac	100.0 %			0.73	0.82

Parker Auto Plaza
Time of Concentration (Developed)

Basin	Contributing Basins	Slope		Length		C _s	Velocity		t _c		Comp. t _c	t _c Check	Final t _c
		O'land	Travel	O'land	Travel		O'land	Travel (Fig. RO-1)	O'land (t _c)	Travel (t _c)			
1A		8.0 %	3.0 %	85 lf	430 lf	0.14	0.2 ft/sec	3.4 ft/sec	8.0 min.	2.1 min.	10.1 min.	12.9 min.	10.1 min.
2A		3.0 %	3.0 %	100 lf	360 lf	0.14	0.1 ft/sec	3.4 ft/sec	12.0 min.	1.8 min.	13.8 min.	12.6 min.	12.6 min.
3A		1.0 %	3.0 %	80 lf	410 lf	0.14	0.1 ft/sec	3.4 ft/sec	15.5 min.	2.0 min.	17.5 min.	12.7 min.	12.7 min.
4A		3.0 %	1.3 %	70 lf	350 lf	0.14	0.1 ft/sec	2.2 ft/sec	10.0 min.	2.7 min.	12.7 min.	12.3 min.	12.3 min.
5A		4.0 %	1.0 %	110 lf	50 lf	0.14	0.2 ft/sec	1.6 ft/sec	11.4 min.	0.5 min.	11.9 min.	10.9 min.	10.9 min.
1B		3.0 %	1.5 %	20 lf	500 lf	0.14	0.1 ft/sec	2.3 ft/sec	5.4 min.	3.6 min.	9.0 min.	12.9 min.	9.0 min.
2B		1.0 %	1.5 %	200 lf	550 lf	0.14	0.1 ft/sec	2.3 ft/sec	24.4 min.	4.0 min.	28.4 min.	14.2 min.	14.2 min.
3B		3.0 %	1.0 %	60 lf	230 lf	0.14	0.1 ft/sec	2.0 ft/sec	9.3 min.	1.9 min.	11.2 min.	11.6 min.	11.2 min.
4B		8.0 %	2.5 %	30 lf	350 lf	0.14	0.1 ft/sec	3.1 ft/sec	4.7 min.	1.9 min.	6.6 min.	12.1 min.	6.6 min.
5B		8.0 %	2.0 %	40 lf	300 lf	0.14	0.1 ft/sec	2.8 ft/sec	5.5 min.	1.8 min.	7.3 min.	11.9 min.	7.3 min.
6B		3.0 %	3.5 %	60 lf	400 lf	0.14	0.1 ft/sec	3.7 ft/sec	9.3 min.	1.8 min.	11.1 min.	12.6 min.	11.1 min.
7B		4.0 %	4.5 %	15 lf	540 lf	0.14	0.1 ft/sec	4.2 ft/sec	4.2 min.	2.1 min.	6.4 min.	13.1 min.	6.4 min.
8B		3.0 %	1.0 %	80 lf	140 lf	0.14	0.1 ft/sec	1.6 ft/sec	10.7 min.	1.5 min.	12.2 min.	11.2 min.	11.2 min.
9B		5.0 %	3.0 %	50 lf	350 lf	0.14	0.1 ft/sec	3.4 ft/sec	7.1 min.	1.7 min.	8.9 min.	12.2 min.	8.9 min.
10B		3.0 %	2.5 %	20 lf	500 lf	0.14	0.1 ft/sec	3.1 ft/sec	5.4 min.	2.7 min.	8.0 min.	12.9 min.	8.0 min.
11B		3.0 %	2.5 %	25 lf	250 lf	0.14	0.1 ft/sec	3.1 ft/sec	6.0 min.	1.3 min.	7.3 min.	11.5 min.	7.3 min.
12B		3.0 %	2.5 %	50 lf	400 lf	0.14	0.1 ft/sec	3.1 ft/sec	8.5 min.	2.2 min.	10.6 min.	12.5 min.	10.6 min.
13B		1.0 %	1.0 %	150 lf	450 lf	0.14	0.1 ft/sec	2.0 ft/sec	21.2 min.	3.8 min.	24.9 min.	13.3 min.	13.3 min.
1C		1.0 %	2.0 %	200 lf	450 lf	0.14	0.1 ft/sec	1.0 ft/sec	24.4 min.	7.5 min.	31.9 min.	13.6 min.	13.6 min.
2C		1.0 %	1.0 %	25 lf	1490 lf	0.14	0.0 ft/sec	1.5 ft/sec	8.6 min.	16.6 min.	25.2 min.	18.4 min.	18.4 min.
3C		2.0 %	1.0 %	150 lf	700 lf	0.14	0.1 ft/sec	3.4 ft/sec	16.8 min.	3.4 min.	20.2 min.	14.7 min.	14.7 min.
4C		1.0 %	1.1 %	10 lf	500 lf	0.14	0.0 ft/sec	2.1 ft/sec	5.5 min.	4.0 min.	9.4 min.	12.8 min.	9.4 min.
5C		2.0 %	1.0 %	60 lf	200 lf	0.14	0.1 ft/sec	3.4 ft/sec	10.6 min.	1.0 min.	11.6 min.	11.4 min.	11.4 min.
6C		2.0 %	1.0 %	10 lf	340 lf	0.14	0.0 ft/sec	1.6 ft/sec	4.3 min.	3.5 min.	7.9 min.	11.9 min.	7.9 min.
7C		2.0 %	1.0 %	10 lf	220 lf	0.90	0.2 ft/sec	3.4 ft/sec	0.9 min.	1.1 min.	5.0 min.	11.3 min.	5.0 min.
1D		2.0 %	2.0 %	10 lf	350 lf	0.14	0.0 ft/sec	2.8 ft/sec	4.3 min.	2.1 min.	6.4 min.	12.0 min.	6.4 min.
2D		10.0 %	3.0 %	30 lf	100 lf	0.14	0.1 ft/sec	3.4 ft/sec	4.4 min.	0.5 min.	5.0 min.	10.7 min.	5.0 min.
3D		10.0 %	3.0 %	10 lf	400 lf	0.14	0.1 ft/sec	3.4 ft/sec	2.5 min.	2.0 min.	5.0 min.	12.3 min.	5.0 min.
DP 1	A Basins	1.0 %	3.0 %	80 lf	410 lf	0.14	0.1 ft/sec	3.4 ft/sec	15.5 min.	2.0 min.	17.5 min.	12.7 min.	12.7 min.
DP 2	B Basins	3.0 %	1.5 %	80 lf	1560 lf	0.14	0.1 ft/sec	2.3 ft/sec	10.7 min.	11.3 min.	22.0 min.	19.1 min.	19.1 min.

Equations:

$$t_i (\text{Overland}) = 1.8(1.1 - C_s)L^{0.5} S^{-0.333}$$

C_s = Runoff coefficient for five-year flow

L = Length of overland flow in feet

S = Slope of flow path in percent

$$t_c \text{ Check} = (L/180) + 10$$

L = Overall Length

Fig. RO-1: Average velocities for Estimating Travel Time

Parker Auto Plaza
Basin Runoff Calculation (Developed)

Basin	Contributing Basins	Area		C _s	C ₁₀₀	Time of Concentration	Rainfall Intensity		Runoff		Basin
							i ₅	i ₁₀₀	Q _s	Q ₁₀₀	
1A		124,700 sf	2.86 ac	0.81	0.88	10.1 min.	3.7 in/hr	7.0 in/hr	8.7 cfs	17.7 cfs	1A
2A		158,280 sf	3.63 ac	0.81	0.88	12.6 min.	3.4 in/hr	6.4 in/hr	10.1 cfs	20.5 cfs	2A
3A		149,800 sf	3.44 ac	0.81	0.88	12.7 min.	3.4 in/hr	6.4 in/hr	9.5 cfs	19.3 cfs	3A
4A		175,180 sf	4.02 ac	0.81	0.88	12.3 min.	3.4 in/hr	6.4 in/hr	11.2 cfs	22.8 cfs	4A
5A		65,250 sf	1.50 ac	0.14	0.40	10.9 min.	3.6 in/hr	6.8 in/hr	0.8 cfs	4.1 cfs	5A
1B		26,630 sf	0.61 ac	0.81	0.88	9.0 min.	3.9 in/hr	7.3 in/hr	1.9 cfs	3.9 cfs	1B
2B		40,850 sf	0.94 ac	0.54	0.66	14.2 min.	3.2 in/hr	6.1 in/hr	1.6 cfs	3.8 cfs	2B
3B		114,100 sf	2.62 ac	0.81	0.88	11.2 min.	3.6 in/hr	6.7 in/hr	7.6 cfs	15.5 cfs	3B
4B		83,300 sf	1.91 ac	0.81	0.88	6.6 min.	4.4 in/hr	8.1 in/hr	6.7 cfs	13.7 cfs	4B
5B		71,200 sf	1.63 ac	0.81	0.88	7.3 min.	4.2 in/hr	7.9 in/hr	5.6 cfs	11.4 cfs	5B
6B		63,550 sf	1.46 ac	0.81	0.88	11.1 min.	3.6 in/hr	6.7 in/hr	4.3 cfs	8.7 cfs	6B
7B		51,720 sf	1.19 ac	0.81	0.88	6.4 min.	4.4 in/hr	8.2 in/hr	4.2 cfs	8.6 cfs	7B
8B		80,100 sf	1.84 ac	0.14	0.40	11.2 min.	3.6 in/hr	6.7 in/hr	0.9 cfs	4.9 cfs	8B
9B		116,400 sf	2.67 ac	0.81	0.88	8.9 min.	3.9 in/hr	7.4 in/hr	8.5 cfs	17.3 cfs	9B
10B		46,600 sf	1.07 ac	0.81	0.88	8.0 min.	4.1 in/hr	7.6 in/hr	3.5 cfs	7.2 cfs	10B
11B		59,600 sf	1.37 ac	0.81	0.88	7.3 min.	4.2 in/hr	7.9 in/hr	4.7 cfs	9.5 cfs	11B
12B		100,200 sf	2.30 ac	0.81	0.88	10.6 min.	3.7 in/hr	6.9 in/hr	6.8 cfs	13.9 cfs	12B
13B		65,200 sf	1.50 ac	0.81	0.88	13.3 min.	3.3 in/hr	6.2 in/hr	4.0 cfs	8.2 cfs	13B
1C		72,910 sf	1.67 ac	0.54	0.66	13.6 min.	3.3 in/hr	6.2 in/hr	3.0 cfs	6.8 cfs	1C
2C		361,300 sf	8.29 ac	0.14	0.40	18.4 min.	2.9 in/hr	5.3 in/hr	3.3 cfs	17.7 cfs	2C
3C		43,100 sf	0.99 ac	0.81	0.88	14.7 min.	3.2 in/hr	6.0 in/hr	2.6 cfs	5.2 cfs	3C
4C		32,500 sf	0.75 ac	0.81	0.88	9.4 min.	3.8 in/hr	7.2 in/hr	2.3 cfs	4.7 cfs	4C
5C		42,640 sf	0.98 ac	0.81	0.88	11.4 min.	3.6 in/hr	6.7 in/hr	2.8 cfs	5.7 cfs	5C
6C		22,020 sf	0.51 ac	0.81	0.88	7.9 min.	4.1 in/hr	7.7 in/hr	1.7 cfs	3.4 cfs	6C
7C		37,700 sf	0.87 ac	0.90	0.96	5.0 min.	4.7 in/hr	8.8 in/hr	3.7 cfs	7.3 cfs	7C
1D		21,080 sf	0.48 ac	0.81	0.88	6.4 min.	4.4 in/hr	8.2 in/hr	1.7 cfs	3.5 cfs	1D
2D		17,360 sf	0.40 ac	0.81	0.88	5.0 min.	4.7 in/hr	8.8 in/hr	1.5 cfs	3.1 cfs	2D
3D		25,680 sf	0.59 ac	0.81	0.88	5.0 min.	4.7 in/hr	8.8 in/hr	2.3 cfs	4.6 cfs	3D
DP 1	A Basins	673,210 sf	15.45 ac	0.75	0.83	12.7 min.	3.4 in/hr	6.4 in/hr	39 cfs	82 cfs	DP 1
DP 2	B Basins	919,450 sf	21.11 ac	0.74	0.83	19.1 min.	2.8 in/hr	5.2 in/hr	44 cfs	92 cfs	DP 2

Equations:

$$I = (28.5P) / (10 + t_c)^{0.786}$$

P=One-hour point rainfall depth (in.) P(5yr)=1.39in. P(100yr)=2.60in.

i₅, i₁₀, i₁₀₀=Average 5, 10 and 100-year Rainfall Intensity in inches per hour (Fig 5.1, Town of Parker Storm Drainage and Environmental Criteria Manual)

$$Q = CiA$$

Q = Peak Runoff Rate, in cubic feet per second (cfs) {Initial Storm=Q_s Major Storm=Q₁₀₀}

C = Runoff coefficient representing a ration of peak runoff rate to average rainfall intensity for a duration equal to the runoff time of concentration.

i = average rainfall intensity in inches per hour

A = Drainage area in acres

TABLE RO-3

Recommended Percentage Imperviousness Values

Land Use or Surface Characteristics	Percentage Imperviousness
Business:	
Commercial areas	95
Neighborhood areas	85
Residential:	
Single-family	*
Multi-unit (detached)	60
Multi-unit (attached)	75
Half-acre lot or larger	*
Apartments	80
Industrial:	
Light areas	80
Heavy areas	90
Parks, cemeteries	5
Playgrounds	10
Schools	50
Railroad yard areas	15
Undeveloped Areas:	
Historic flow analysis	2
Greenbelts, agricultural	2
Off-site flow analysis (when land use not defined)	45
Streets:	
Paved	100
Gravel (packed)	40
Drive and walks	90
Roofs	90
Lawns, sandy soil	0
Lawns, clayey soil	0

* See Figures RO-3 through RO-5 for percentage imperviousness.

Based in part on the data collected by the District since 1969, an empirical relationship between C and the percentage imperviousness for various storm return periods was developed. Thus, values for C can be determined using the following equations (Urbonas, Guo and Tucker 1990).

$$C_A = K_A + (1.31i^3 - 1.44i^2 + 1.135i - 0.12) \text{ for } C_A \geq 0, \text{ otherwise } C_A = 0 \quad (\text{RO-6})$$

$$C_{CD} = K_{CD} + (0.858i^3 - 0.786i^2 + 0.774i + 0.04) \quad (\text{RO-7})$$

$$C_B = (C_A + C_{CD})/2$$

in which:

i = % imperviousness/100 expressed as a decimal (see Table RO-3)

TABLE RO-5
Runoff Coefficients, C

Percentage Imperviousness	Type C and D NRCS Hydrologic Soil Groups					
	2-yr	5-yr	10-yr	25-yr	50-yr	100-yr
0%	0.04	0.15	0.25	0.37	0.44	0.50
5%	0.08	0.18	0.28	0.39	0.46	0.52
10%	0.11	0.21	0.30	0.41	0.47	0.53
15%	0.14	0.24	0.32	0.43	0.49	0.54
20%	0.17	0.26	0.34	0.44	0.50	0.55
25%	0.20	0.28	0.36	0.46	0.51	0.56
30%	0.22	0.30	0.38	0.47	0.52	0.57
35%	0.25	0.33	0.40	0.48	0.53	0.57
40%	0.28	0.35	0.42	0.50	0.54	0.58
45%	0.31	0.37	0.44	0.51	0.55	0.59
50%	0.34	0.40	0.46	0.53	0.57	0.60
55%	0.37	0.43	0.48	0.55	0.58	0.62
60%	0.41	0.46	0.51	0.57	0.60	0.63
65%	0.45	0.49	0.54	0.59	0.62	0.65
70%	0.49	0.53	0.57	0.62	0.65	0.68
75%	0.54	0.58	0.62	0.66	0.68	0.71
80%	0.60	0.63	0.66	0.70	0.72	0.74
85%	0.66	0.68	0.71	0.75	0.77	0.79
90%	0.73	0.75	0.77	0.80	0.82	0.83
95%	0.80	0.82	0.84	0.87	0.88	0.89
100%	0.89	0.90	0.92	0.94	0.95	0.96

Type B NRCS Hydrologic Soils Group						
0%	0.02	0.08	0.15	0.25	0.30	0.35
5%	0.04	0.10	0.19	0.28	0.33	0.38
10%	0.06	0.14	0.22	0.31	0.36	0.40
15%	0.08	0.17	0.25	0.33	0.38	0.42
20%	0.12	0.20	0.27	0.35	0.40	0.44
25%	0.15	0.22	0.30	0.37	0.41	0.46
30%	0.18	0.25	0.32	0.39	0.43	0.47
35%	0.20	0.27	0.34	0.41	0.44	0.48
40%	0.23	0.30	0.36	0.42	0.46	0.50
45%	0.26	0.32	0.38	0.44	0.48	0.51
50%	0.29	0.35	0.40	0.46	0.49	0.52
55%	0.33	0.38	0.43	0.48	0.51	0.54
60%	0.37	0.41	0.46	0.51	0.54	0.56
65%	0.41	0.45	0.49	0.54	0.57	0.59
70%	0.45	0.49	0.53	0.58	0.60	0.62
75%	0.51	0.54	0.58	0.62	0.64	0.66
80%	0.57	0.59	0.63	0.66	0.68	0.70
85%	0.63	0.66	0.69	0.72	0.73	0.75
90%	0.71	0.73	0.75	0.78	0.80	0.81
95%	0.79	0.81	0.83	0.85	0.87	0.88
100%	0.89	0.90	0.92	0.94	0.95	0.96

TYPE B

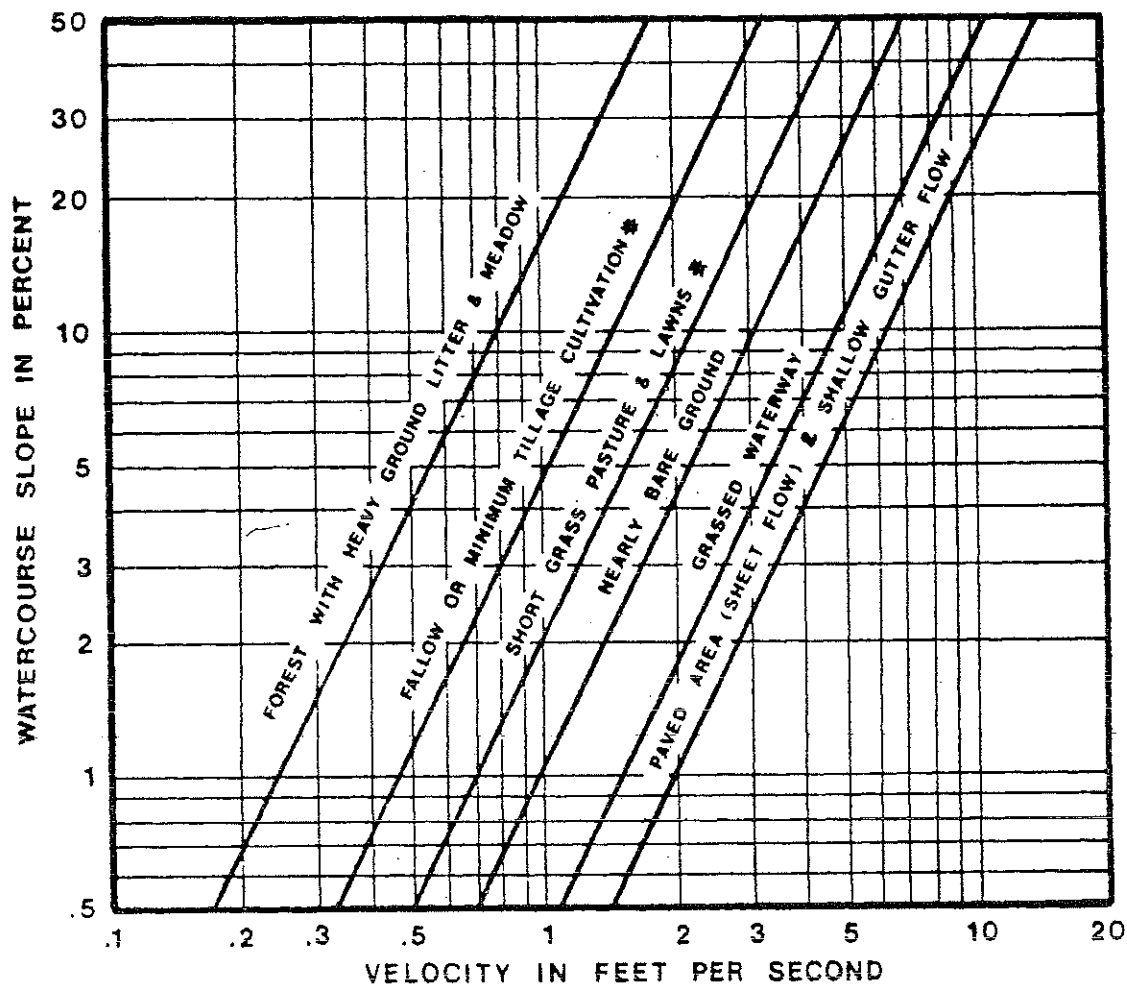

FIGURE RO-1

Estimate of Average Overland Flow Velocity for Use With the Rational Formula

5.1 INTRODUCTION

This section presents the criteria and methodology for determining storm runoff design peaks and volumes to be used in the Town of Parker for preparation of storm drainage plans and facility design. In general hydrologic analysis of the initial and major storm events for both the historic and fully developed site conditions are required. In addition to the hydrologic analysis for a site, a hydrologic analysis should be performed for all off site basins that impact the proposed site. The Town of Parker adopts procedures prescribed by the Urban Drainage and Flood Control District (District) for performing hydrologic analysis. These procedures may be found in the Rainfall and Runoff sections of the MANUAL. Standards and technical criteria found in the MANUAL should be followed except where superseded by specific requirements of this criteria MANUAL.

5.2 DESIGN RAINFALL

For any storm runoff technique, design rainfall must first be established. The design rainfall data to be used for the Town of Parker were obtained from NOAA Atlas 2, Precipitation-Frequency Atlas of the Western United States, Volume III- Colorado. The design storm events developed and utilized are the same as those used by the District.

The one-hour point rainfall depths for different frequency events are shown in Table 5.1. Rainfall intensity as a function of the one-hour point rainfall and the time of concentration can be approximated by the following equation which appears in the MANUAL as Equation RA-5.

$$I = (28.5P_1)/(10+t_c)^{0.786}$$

Where, I = rainfall intensity (in/hr)
 P_1 = one-hour point rainfall depth (in)
 t_c = time of concentration (min)

Graphical presentation of the equation is shown as the Time-Intensity-Frequency curves in Figure 5.1. Rainfall intensity for use in the Rational Method may be taken from Figure 5.1 or calculated using the equation.

Table 5.1
ONE-HOUR POINT RAINFALL

Frequency of Design Event (yr)	One-hour Point Rainfall, P_1 (in)
2	0.99
5	1.39
10	1.64
25	1.98
50	2.31
100	2.60

Intensity, Duration, Frequency
Parker, Colorado

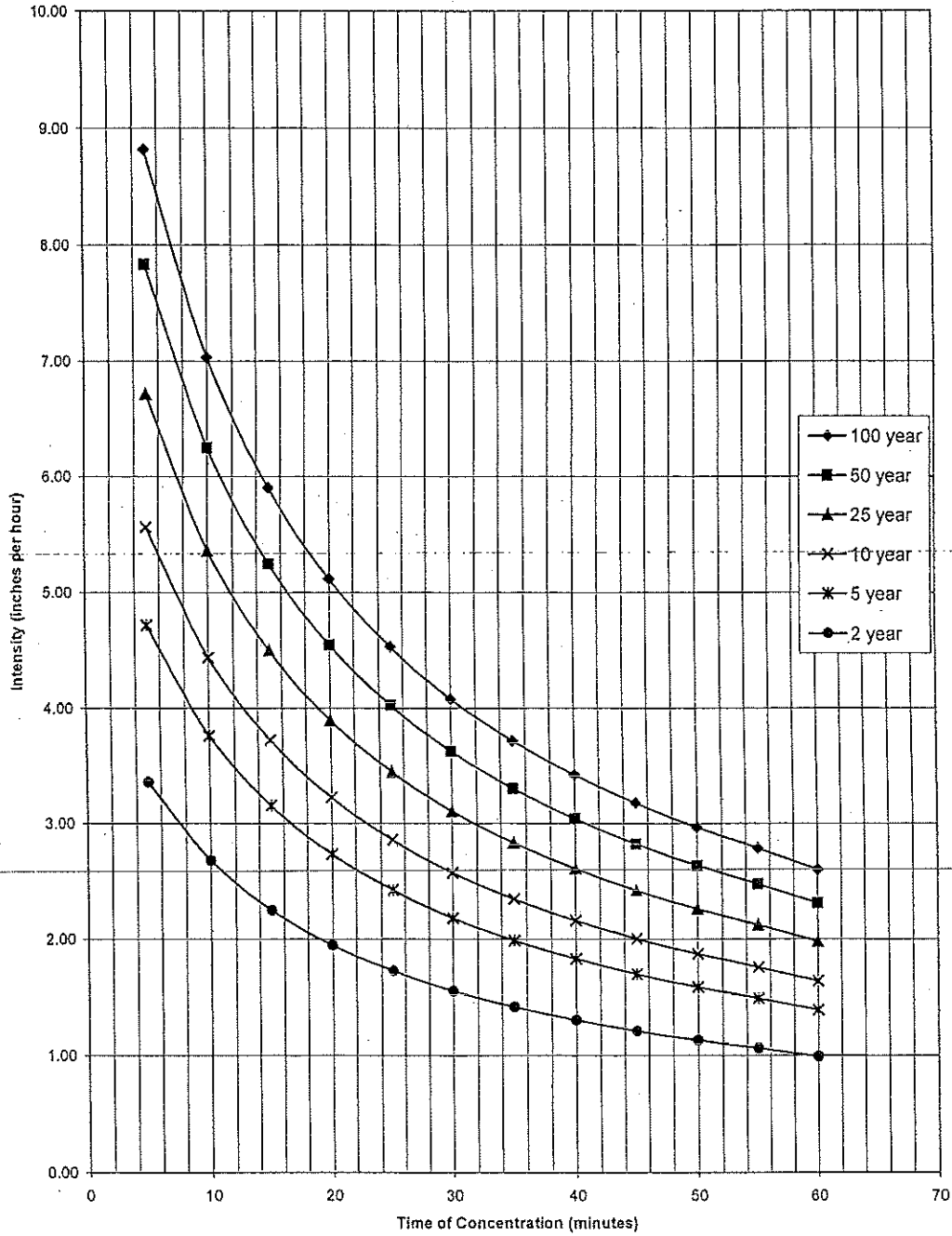

Figure 5.1 Rainfall Intensity Versus Duration Curves for Parker, Colorado

APPENDIX B
Hydraulic Calculations

Table 2.3

**RECURRENCE INTERVALS (years) FOR
INITIAL AND MAJOR STORM RUNOFF DESIGN**

Land use	Initial Storm	Major Storm
Residential	2	100
Open Space/Agricultural	2	100
School	2	100
Commercial/Business/Industrial	5	100

2.5.1 STREETS

Streets are an integral part of the urban drainage system and may be used for transporting storm runoff up to design limits. The design engineer should recognize that the primary purpose of streets is for traffic. Therefore, use of streets for storm runoff must be limited.

Although street criteria are formulated to allow certain drainage, streets should not routinely be considered as major drainageways. The Town of Parker, prohibits the practice of discharging offsite culverts and other non-local drainage outfalls onto streets. Storm drains should not outfall onto streets, but should be piped to suitable outfalls in a swale, channel, or detention basin. Street criteria should be applied to storm runoff flows emanating from building lots and other streets rather than discharges from major offsite drainageways flowing into streets.

Town of Parker criteria for allowable uses and depth of flow for initial and major storm runoff events is presented in Table 2.4, Table 2.5, and Table 2.6

Table 2.4

ALLOWABLE USE OF STREETS FOR INITIAL STORM RUNOFF

Street Classification	Maximum Theoretical Encroachment
Local	No curb overtopping. Flow may spread to crown of street.
Collector	No curb overtopping. Flow spread must leave at least a 10 foot width free of water.
Arterial	No curb overtopping. Flow spread must leave at least two lanes free of water, one 10 foot lane each direction.

Where no curbing exists, encroachment should not extend past the street right-of-way. The maximum allowable street flow shall be the product of the flow calculated at "maximum theoretical street encroachment" and required reduction factor. See Section 6.4

Parker Auto Plaza
Inlet Capacity Summary

Inlet	Location	Inlet Size	Inlet Condition	5yr Flow	5yr Flow Spread	100yr Flow + Carry Over to Inlet	100yr Inlet Capacity	100yr Flow Past Inlet	Downstream Inlet if Carry Over	Contributing Flows
1	Interior	10 ft	Sump			17.9 cfs	17.2 cfs	1 cfs		Basin 1A
2	Interior	15 ft	Sump			20.7 cfs	24.3 cfs	(4 cfs)		Basin 2A
3	Interior	10 ft	Sump			19.5 cfs	19.1 cfs	0 cfs		Basin 3A
4	Interior	10 ft	Sump			23.1 cfs	19.5 cfs	4 cfs		Basin 4A
10	20 Mile Rd	15 ft	Grade	1.9 cfs	7.3 ft	3.7 cfs	3.6 cfs	0 cfs	Off Site	Basin 1B
11	20 Mile Rd	10 ft	Grade	1.6 cfs	6.6 ft	3.8 cfs	3.0 cfs	1 cfs	Inlet 18	Basin 2B
12	Interior	10 ft	Sump			8.2 cfs	9.2 cfs	(1 cfs)		Basin 13B
13	Interior	10 ft	Sump			13.7 cfs	13.5 cfs	0 cfs		Basin 4B
14	Interior	10 ft	Sump			11.4 cfs	13.6 cfs	(2 cfs)		Basin 5B
15	Interior	5 ft	Sump			8.8 cfs	8.2 cfs	1 cfs	Detention Basin	Basin 6B
16	Dransfeldt	15 ft	Grade	2.1 cfs	5.5 ft	4.3 cfs	3.6 cfs	1 cfs	Inlet 27	1/2 Basin 7B
16a	Dransfeldt	15 ft	Grade	2.1 cfs	5.5 ft	4.3 cfs	3.6 cfs	1 cfs	Inlet 27	1/2 Basin 7B
17	Interior	15 ft	Sump			17.3 cfs	18.9 cfs	(2 cfs)		Basin 9B
18	20 Mile Rd	15 ft	Grade	3.5 cfs	12.3 ft	7.2 cfs	6.4 cfs	1 cfs	Off Site to the west	Basin 10B, Carry Inlet 11
19	Interior	10 ft	Sump			9.5 cfs	11.3 cfs	(2 cfs)		Basin 11B
20	Interior	10 ft	Sump			13.9 cfs	18.3 cfs	(4 cfs)		Basin 12B
21	Interior	10 ft	Sump			15.5 cfs	15.5 cfs	0 cfs		Basin 3B
25	20 Mile Rd	10 ft	Sump	2.8 cfs	9.1 ft	7.0 cfs	11.6 cfs	(5 cfs)		Basin 5C, Carry Inlet 27
26	20 Mile Rd	3.25 ft	Sump	1.7 cfs	6.9 ft	4.3 cfs	5.8 cfs	(2 cfs)		Basin 6C, Carry Inlet 27a
27	20 Mile Rd	10 ft	Grade	2.6 cfs	13.7 ft	5.9 cfs	3.4 cfs	3 cfs	Inlet 25	Basin 3C, Carry Inlet 16,16a
27a	20 Mile Rd	10 ft	Grade	2.3 cfs	10.9 ft	4.7 cfs	2.9 cfs	2 cfs	Inlet 26	Basin 4C
28	20 Mile Rd	5 ft	Grade	1.5 cfs	10.1 ft	3.1 cfs	1.6 cfs	2 cfs		Basin 2D
40	Parker Rd	5 ft	Sump	3.7 cfs	8.6 ft	7.3 cfs	6.2 cfs	1 cfs	Baldwin Gulch	Basin 7C

Town of Parker Criteria (Pg 6-15, Section 6.3.5): A 50% reduction factor should be used on carry over flows when determining the amount of flow entering a downstream inlet, due to Carry Over.

Table 2.4: Allowable Use of Streets for Initial Storm Runoff (5-year Runoff)

Collector: No curb overtopping. Flow spread must leave at least a 10-ft width free of water.

Dransfeldt Rd Maximum Flow Spread = 16.0 ft

Arterial: No curb overtopping. Flow spread must leave at least two lanes free of water, one 10-ft lane each direction.

Twenty Mile Rd Maximum Flow Spread = 17.0 ft

APPENDIX C
Detention Basin Calculations

Parker Auto Plaza
Detention Basin Calculations

WQCV = 0.45 inches
% Impervious(I) = 95 %

WQCV (Water Quality Capture Volume) taken from Fig. EDB-2, Volume 3 of the Urban Storm Drainage Criteria Manual for the basin imperviousness shown.
Percent Impervious taken from Table RO-3, Volume 1 of the Urban Storm Drainage Criteria Manual

WQCV = 0.045 * A
WQCV = WQCV/12 * A * 1.2
A = Area

Required Detention Storage Volume = $K_x A$

$K_{10} = 0.08835$
 $K_{100} = 0.14749$

$K_{10} = (0.95I - 1.9)/1000$
 $K_{100} = (1.78I - 0.002I^2 - 3.56)/1000$

Unit Flow Release Rate (cfs/acre)

Hydrologic Soil Group **B**
 $U_{10} = 0.23$
 $U_{100} = 0.85$

Basin	Total Acres	V_{10}		V_{100}		WQCV		10-yr Required Capacity		100-yr Required Capacity		Release Rate	
		ac-ft	cf	ac-ft	cf	ac-ft	cf	ac-ft	cf	ac-ft	cf	Q_{10}	Q_{100}
Detention Basin A	15.45 ac	1.37 ac-ft	59,460 cf	2.28 ac-ft	99,261 cf	0.70 ac-ft	30,285 cf	2.06 ac-ft	89,745 cf	2.97 ac-ft	129,546 cf	3.6 cfs	13.1 cfs
Detention Basin B	21.20 ac	1.87 ac-ft	81,589 cf	3.13 ac-ft	136,203 cf	0.95 ac-ft	41,556 cf	2.83 ac-ft	123,145 cf	4.08 ac-ft	177,759 cf	4.9 cfs	18.0 cfs

$V_x = K_x A$

Release Rate = Area * U_x

U_x = Recommended Maximum Allowable Unit Flow Release Rates (cfs/acre) of Tributary Catchment (Table SO-1, Urban Drainage and Flood Control District - Volume 2)

Parker Auto Plaza
Detention Basin Calculations

Presedimentation / Forebay Sizing

Detention Basin A

WQCV	30,285 cf
10% WQCV	3,029 cf
Orifice Eqn Coef. (C)	0.50

Forebay Pipe Number	Flow	% Total Flow	Weighted Forebay Area	Forebay Size			5 Minute Drain Flow	Pipes Out of Forebay - Orifice Calculation						Total Flow
				Depth	Surface Area	Semicirc. Radii		Pipe 1 Diameter	Pipe 1 Flow	Pipe 2 Diameter	Pipe 2 Flow	Pipe 3 Diameter	Pipe 3 Flow	
S2	37 cfs	46.84 %	1,418 cf	2.0 ft	709 sf	21 ft	4.7 cfs	8 inches	1.8 cfs	10 inches	2.8 cfs	0 inches	0.0 cfs	4.6 cfs
S3	19 cfs	24.05 %	728 cf	2.0 ft	364 sf	15 ft	2.4 cfs	6 inches	1.0 cfs	6 inches	1.0 cfs	0 inches	0.0 cfs	2.1 cfs
S4	23 cfs	29.11 %	882 cf	2.0 ft	441 sf	17 ft	2.9 cfs	6 inches	1.0 cfs	8 inches	1.8 cfs	0 inches	0.0 cfs	2.9 cfs
	79.0 cfs	100.00 %	3,029 cf											9.5 cfs

Orifice Equation:

$$Q = CA(2gH)^{0.5}$$

C = Orifice coefficient (dimensionless)

A = Cross-sectional area of opening, in sf

g = Gravitational acceleration constant, 32.2 ft/sec²

H = Head above the centerline of the pipe, in ft

Detention Basin B

WQCV	41,556 cf
10% WQCV	4,156 cf
Orifice Eqn Coef. (C)	0.50

Forebay Pipe Number	Flow	% Total Flow	Weighted Forebay Area	Forebay Size			5 Minute Drain Flow	Pipes Out of Forebay - Orifice Calculation						Total Flow
				Depth	Surface Area	Semicirc. Radii		Pipe 1 Diameter	Pipe 1 Flow	Pipe 2 Diameter	Pipe 2 Flow	Pipe 3 Diameter	Pipe 3 Flow	
S10	92 cfs	100.00 %	4,156 cf	2.0 ft	2,078 sf	36 ft	13.9 cfs	12 inches	3.9 cfs	12 inches	3.9 cfs	12 inches	3.9 cfs	11.6 cfs
	92.0 cfs	100.00 %	4,156 cf											11.6 cfs

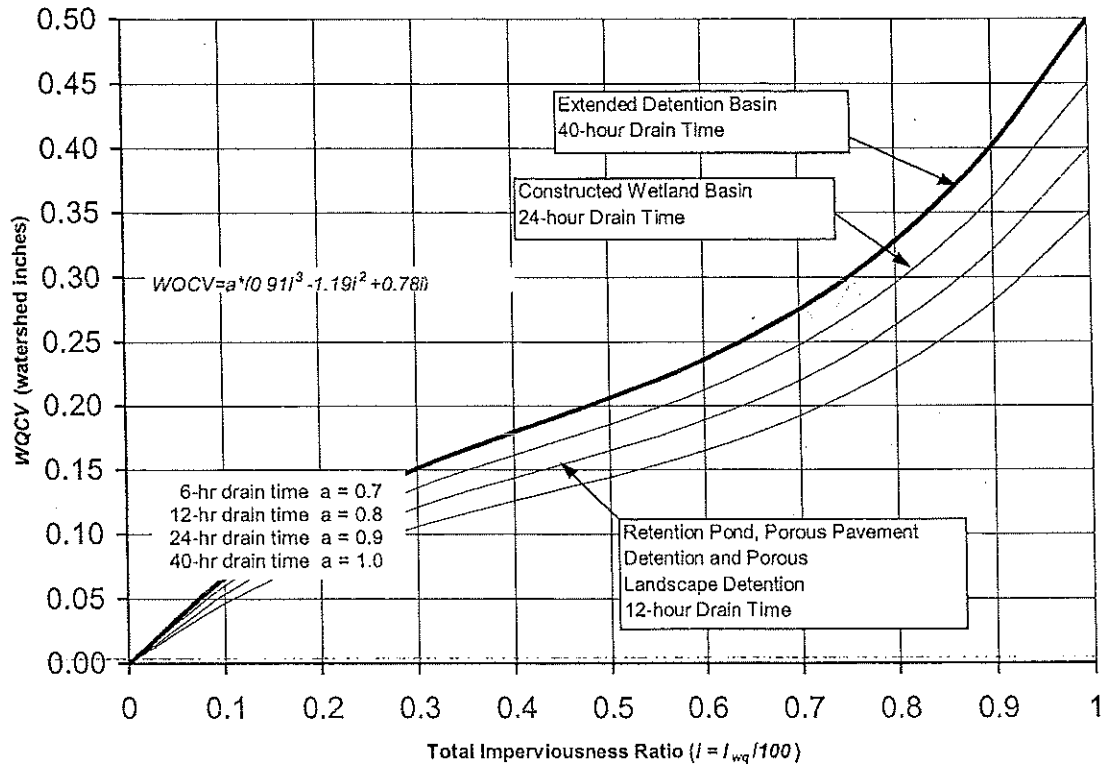

FIGURE EDB-2

Water Quality Capture Volume (WQCV), 80th Percentile Runoff Event

attempt to account for the effects of the WQCV on all control levels whenever it performs watershed-level drainage and flood control system master plans.

3.2 Sizing of On-Site Detention Facilities

3.2.1 Maximum Allowable Unit Release Rates for On-Site Facilities. The maximum allowable unit release rates per acre for on-site detention facilities for a number of design return periods are listed in Table SO-1. These rates apply unless other rates are recommended in a District-approved master plan.

The predominant soil group for the total tributary catchment shall be used for determining the allowable release rates. Multiply the unit rates provided in Table SO-1 by the tributary catchment's area to obtain the actual design release rates in cubic feet per second (cfs). Whenever Natural Resources Conservation Service (NRCS) soil surveys are not available for the portion of a county being studied, extrapolate their types using soil investigations at the site.

TABLE SO-1

Recommended Maximum Allowable Unit Flow Release Rates (cfs/acre) of Tributary Catchment

Design Return Period (Years)	NRCS Hydrologic Soil Group		
	A	B	C & D
2	0.02	0.03	0.04
5	0.07	0.13	0.17
10	0.13	0.23	0.30
25	0.24	0.41	0.52
50	0.33	0.56	0.68
100	0.50	0.85	1.00

3.2.2 Empirical Equations for the Sizing of On-Site Detention Storage Volumes. Urbonas and Glidden (1983), as part of the District's ongoing hydrologic research, conducted studies that evaluated peak storm runoff flows along major drainageways. The following set of empirical equations provided preliminary estimates of on-site detention facility sizing for areas within the District. They are not intended for use when off-site inflows are present or when multi-stage controls are to be used (e.g., 10- and 100-year peak control) at the storage facility. In addition, these equations are not intended to replace detailed hydrologic and flood routing analysis, or even the analysis using the Rational Formula-based FAA method for the sizing of detention storage volumes. The District does not promote the use of these empirical equations. It does not object, however, to their use by local governments who have adopted them or want to adopt them as minimum requirements for the sizing of on-site detention for small catchments within their jurisdiction. If the District has a master plan that contains specific guidance for detention

APPENDIX C.1
Detention Basin A Calculations

Parker Auto Plaza
Detention Basin Earthwork Calculation

Detention Basin A

Elevation	Area	Avg. Area	Volume	Basin Depth	Cumulative Basin Volume		Elevation
77.7	315 sf						
		448 sf	134 cf	0.3 ft	134 cf	0.003 ac-ft	78
78	580 sf						
		3,743 sf	3,743 cf	1.3 ft	3,877 cf	0.09 ac-ft	79
79	6,905 sf						
		13,299 sf	13,299 cf	2.3 ft	17,175 cf	0.39 ac-ft	80
80	19,692 sf						
		22,546 sf	22,546 cf	3.3 ft	39,721 cf	0.91 ac-ft	81
81	25,400 sf						
		27,000 sf	27,000 cf	4.3 ft	66,721 cf	1.53 ac-ft	82
82	28,600 sf						
		30,125 sf	30,125 cf	5.3 ft	96,846 cf	2.22 ac-ft	83
83	31,650 sf						
		33,225 sf	33,225 cf	6.3 ft	130,071 cf	2.99 ac-ft	84
84	34,800 sf						
		36,075 sf	36,075 cf	7.3 ft	166,146 cf	3.81 ac-ft	85
85	37,350 sf						

Water Quality Capture Volume = 30,285 cf
WQCV Elevation = 80.58 ft

10yr Water Volume = 89,745 cf
10yr Water Surface Elevation = 82.76 ft

100yr Water Volume = 129,546 cf
100yr Water Surface Elevation = 83.98 ft

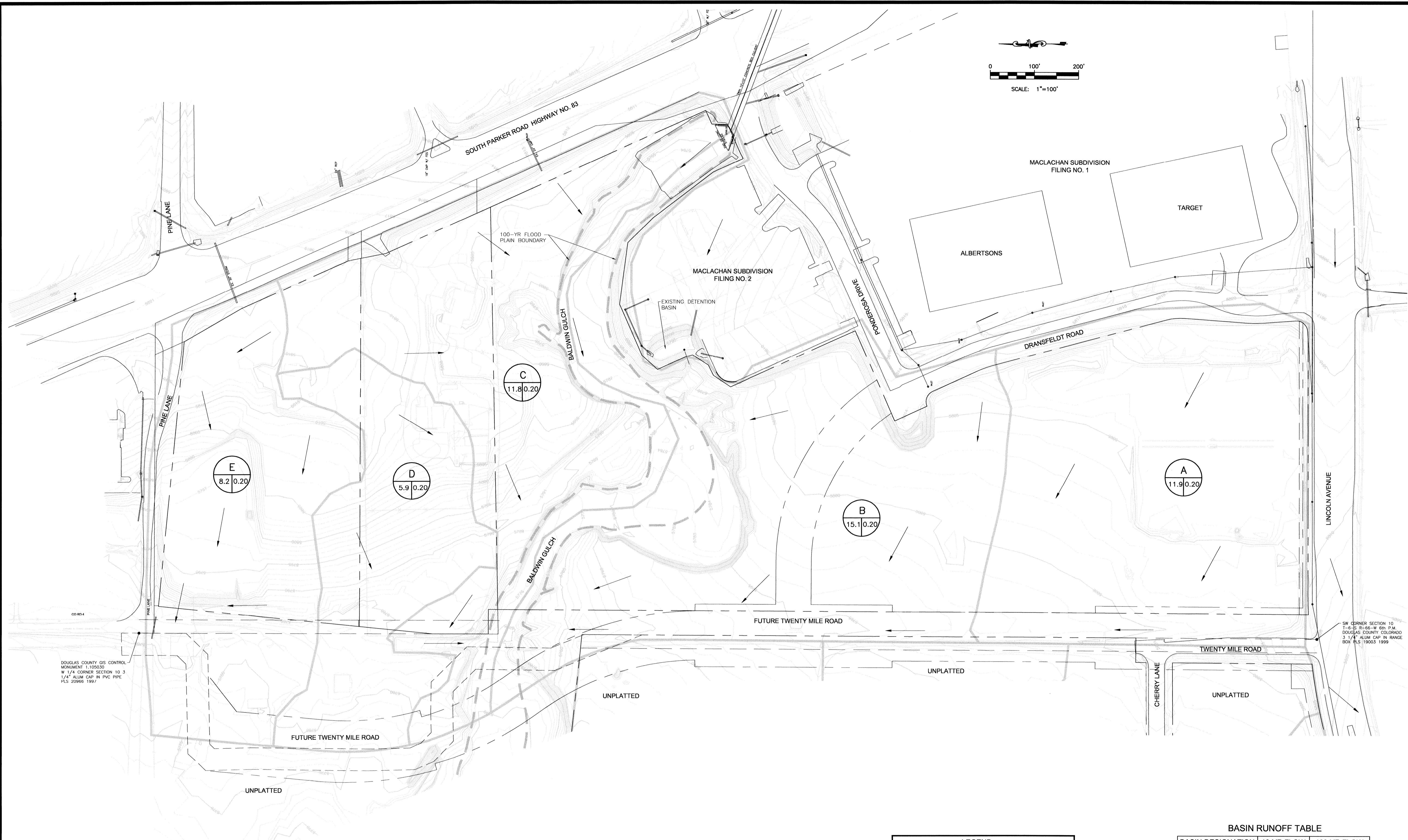

DOUGLAS COUNTY GIS CONTROL MONUMENT 1.105030 W 1/4 CORNER SECTION 10 3 1/4" ALUM COP IN PVC PIPE PLS 20966 1997

SW CORNER SECTION 10 T-4-S R-46-W 6th P.M. DOUGLAS COUNTY COLORADO 3 1/4" ALUM COP IN RANGE BOX PLS 19003 1999

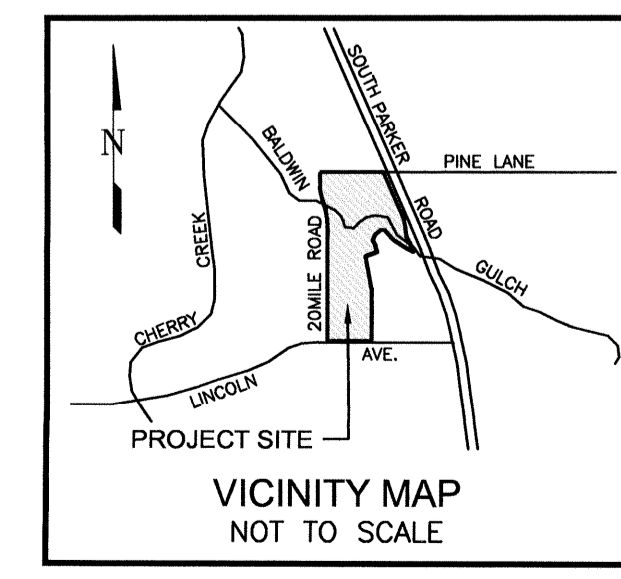

PROJECT DATUM: ALL ELEVATIONS ARE REFERENCED TO NAVD 88 AS SHOWN ON THE 1998 DOUGLAS COUNTY TABULATION

LEGEND	
	BASIN DESIGNATION
	BASIN AREA (AC) / C100 RUNOFF COEFFICIENT
	DIRECTIONAL FLOW ARROW
	EXISTING DRAINAGE BASIN BOUNDARY
	R.O.W. / PROPERTY LINE

BASIN RUNOFF TABLE		
BASIN DESIGNATION	10-YR FLOW	100-YR FLOW
A	1.1 cfs	7.0 cfs
B	1.7 cfs	10.8 cfs
C	1.1 cfs	6.9 cfs
D	0.7 cfs	4.6 cfs
E	0.9 cfs	5.7 cfs

Kiowa Engineering Corporation
 7175 West Jefferson Avenue, Suite 3400
 Lakewood, Colorado 80235
 (303) 692-0369

PARKER AUTO PLAZA
EXISTING DRAINAGE PATTERNS
FINAL DRAINAGE REPORT
 PARKER, COLORADO

Project No.: 00056
 Date: July 12, 2004
 Design: MWE
 Drawn: MWE
 Check: RNW
 Revisions:

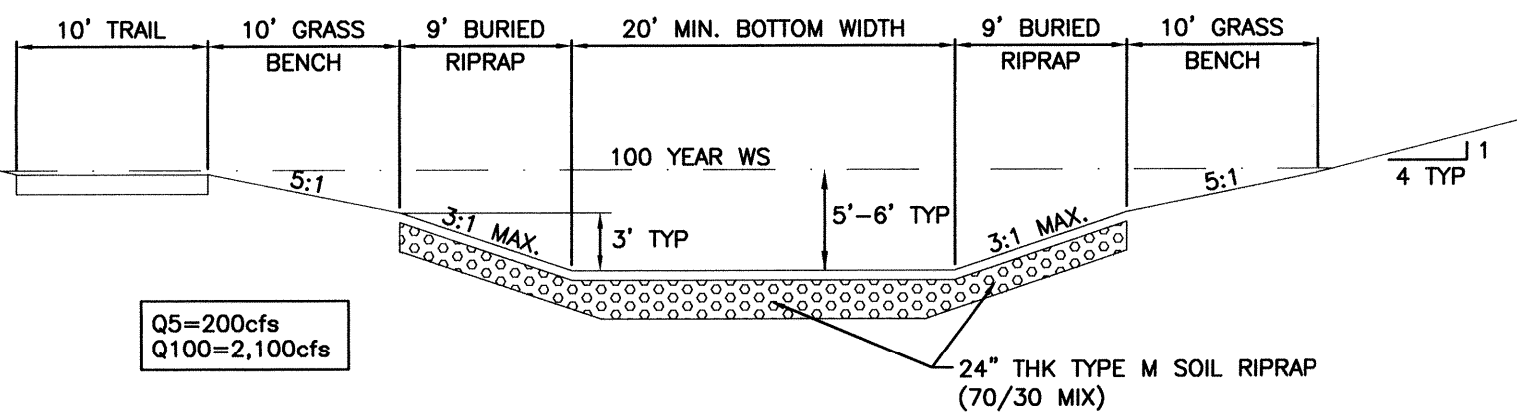
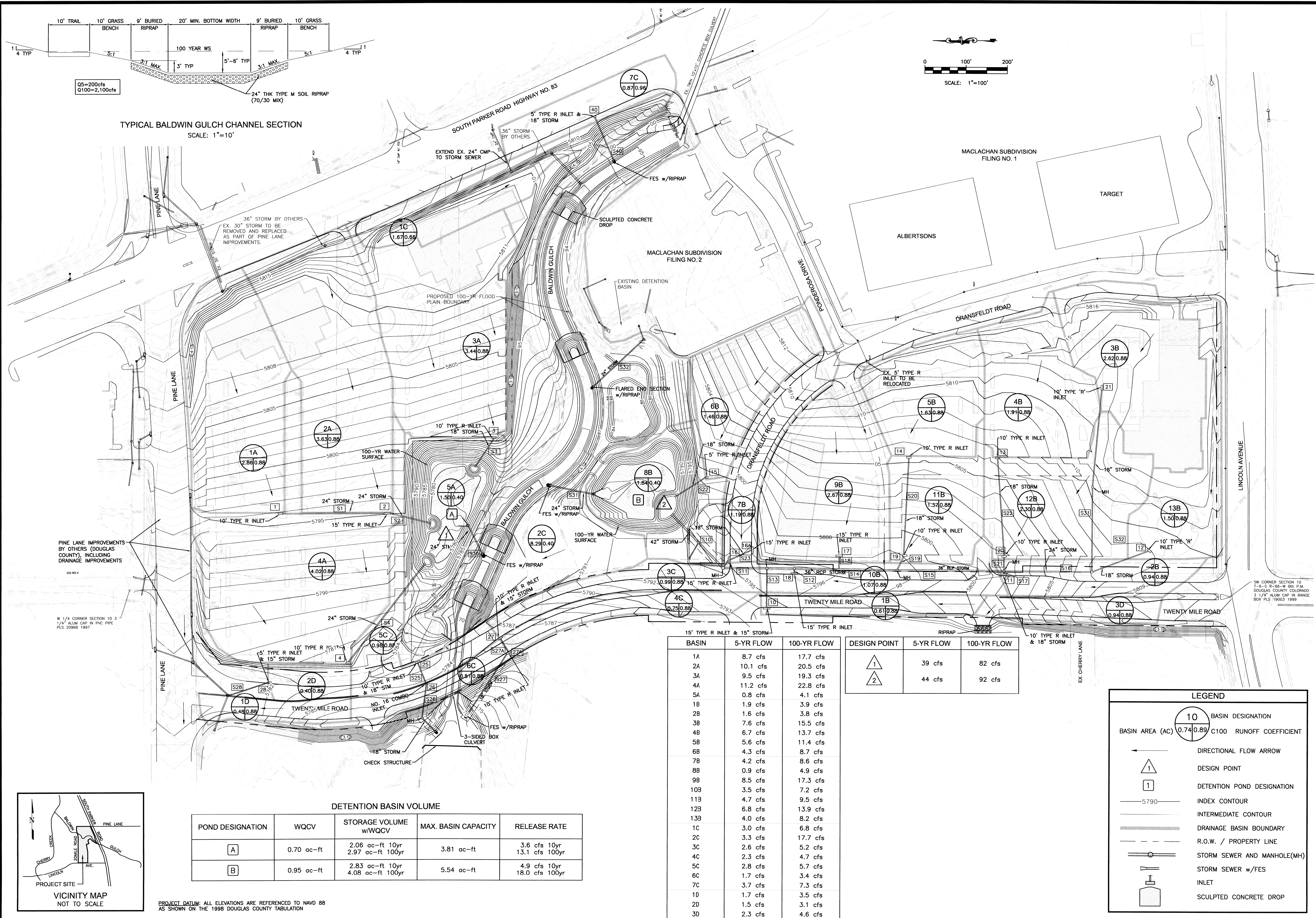

TYPICAL BALDWIN GULCH CHANNEL SECTION
SCALE: 1"=10'

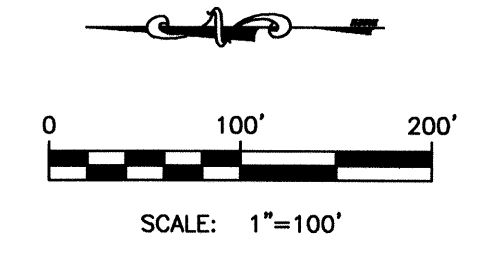

DETENTION BASIN VOLUME

POND DESIGNATION	WQCV	STORAGE VOLUME w/WQCV	MAX. BASIN CAPACITY	RELEASE RATE
A	0.70 ac-ft	2.06 ac-ft 10yr	3.81 ac-ft	3.6 cfs 10yr
		2.97 ac-ft 100yr		13.1 cfs 100yr
B	0.95 ac-ft	2.83 ac-ft 10yr	5.54 ac-ft	4.9 cfs 10yr
		4.08 ac-ft 100yr		18.0 cfs 100yr

BASIN	5-YR FLOW	100-YR FLOW	DESIGN POINT	5-YR FLOW	100-YR FLOW
1A	8.7 cfs	17.7 cfs	1	39 cfs	82 cfs
2A	10.1 cfs	20.5 cfs			
3A	9.5 cfs	19.3 cfs	2	44 cfs	92 cfs
4A	11.2 cfs	22.8 cfs			
5A	0.8 cfs	4.1 cfs			
1B	1.9 cfs	3.9 cfs			
2B	1.6 cfs	3.8 cfs			
3B	7.6 cfs	15.5 cfs			
4B	6.7 cfs	13.7 cfs			
5B	5.6 cfs	11.4 cfs			
6B	4.3 cfs	8.7 cfs			
7B	4.2 cfs	8.6 cfs			
8B	0.9 cfs	4.9 cfs			
9B	8.5 cfs	17.3 cfs			
10B	3.5 cfs	7.2 cfs			
11B	4.7 cfs	9.5 cfs			
12B	6.8 cfs	13.9 cfs			
13B	4.0 cfs	8.2 cfs			
1C	3.0 cfs	6.8 cfs			
2C	3.3 cfs	17.7 cfs			
3C	2.6 cfs	5.2 cfs			
4C	2.3 cfs	4.7 cfs			
5C	2.8 cfs	5.7 cfs			
6C	1.7 cfs	3.4 cfs			
7C	3.7 cfs	7.3 cfs			
1D	1.7 cfs	3.5 cfs			
2D	1.5 cfs	3.1 cfs			
3D	2.3 cfs	4.6 cfs			

LEGEND

10 BASIN DESIGNATION
BASIN AREA (AC) 0.74/0.89 C100 RUNOFF COEFFICIENT

→ DIRECTIONAL FLOW ARROW

△ 1 DESIGN POINT

□ 1 DETENTION POND DESIGNATION

—5790— INDEX CONTOUR

--- INTERMEDIATE CONTOUR

--- DRAINAGE BASIN BOUNDARY

- - - R.O.W. / PROPERTY LINE

—○— STORM SEWER AND MANHOLE(MH)

—|— STORM SEWER w/FES

—|— INLET

—|— SCULPTED CONCRETE DROP

Kiowa Engineering Corporation
7175 West Jefferson Avenue, Suite 3400
Lakewood, Colorado 80235
(303) 692-0369

**PARKER AUTO PLAZA
DEVELOPED DRAINAGE PATTERNS
FINAL DRAINAGE REPORT
PARKER, COLORADO**

Project No.: 00056
Date: July 12, 2004
Design: MWE
Drawn: MWE
Check: RNW
Revisions:

FIGURE
2

K:\DEN_C\1\096502001 - Misc. Files - Parker - RA\CADD\Plan\Sheet\096502001DRM.dwg, 7/20/2019 10:57 AM
 THIS DOCUMENT, TOGETHER WITH ALL CONCEPTS AND DESIGNS PRESENTED HEREIN, IS AN INSTRUMENT OF SERVICE PROVIDED ONLY FOR THE SPECIFIC PROJECT AND SITE INDICATED THEREON. IT IS NOT TO BE REPRODUCED, COPIED, REUSED, OR TRANSMITTED IN ANY FORM OR BY ANY MEANS, WITHOUT THE WRITTEN AUTHORIZATION AND ADAPTATION BY KIMLEY-HORN AND ASSOCIATES, INC. SHALL BE WITHOUT LIABILITY TO KIMLEY-HORN AND ASSOCIATES, INC.

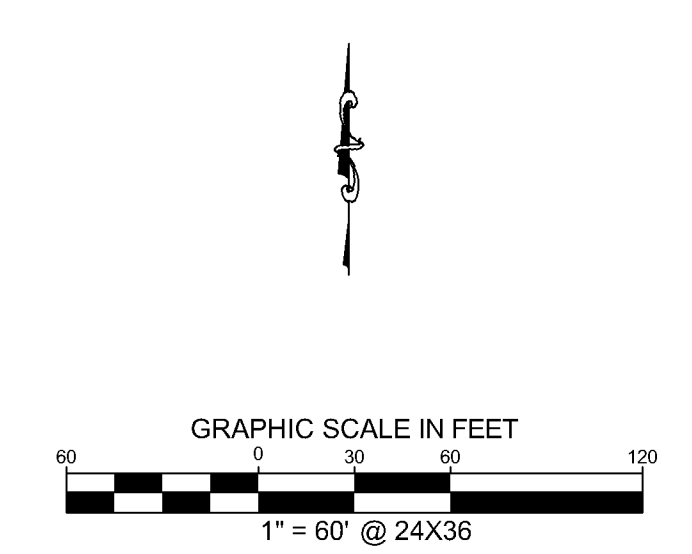
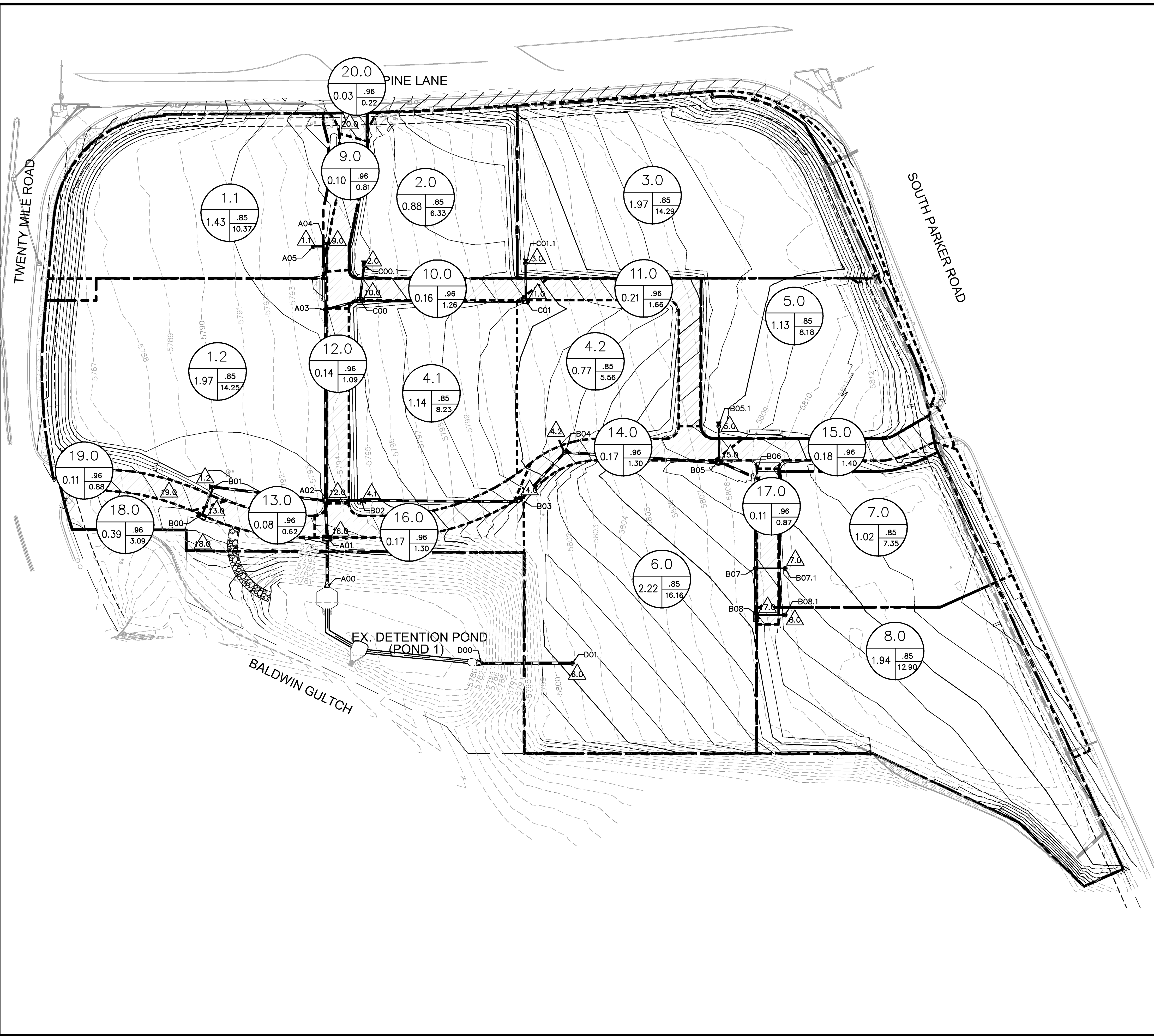

- LEGEND**
- | |
|---|
| A |
| B |
| C |
| D |

 A = BASIN DESIGNATION
 - B = AREA (ACRES)
 - C = BASIN IMPERVIOUSNESS
 - D = 100YR DESIGN STORM RUNOFF (CFS)
 - FLOW DIRECTION
 - DRAINAGE BASIN BOUNDARY
 - EXISTING PROPERTY LINE
 - EXISTING CONTOUR
 - PROPOSED CONTOUR
 - EXISTING STORM SEWER
 - PROPOSED STORM SEWER
 - PROPOSED STORM INLET

NO.	REVISION	BY	DATE	APPR

Kimley»Horn

2019 KIMLEY-HORN AND ASSOCIATES, INC.
 4552 South Ulster Street, Suite 1500
 Denver, Colorado 80237 (303) 228-2300

DESIGNED BY: DLS
 DRAWN BY: ECZ
 CHECKED BY: DLS
 DATE: 11/11/19

PARKER & PINE
 PARKER, CO
 CONSTRUCTION DOCUMENTS
PRELIMINARY DRAINAGE AREA MAP

PRELIMINARY
 FOR REVIEW ONLY
 NOT FOR
 CONSTRUCTION
Kimley»Horn
 Kimley-Horn and Associates, Inc.

PROJECT NO.
 096502001

DRAWING NAME
 096502001DRM
DRAINAGE



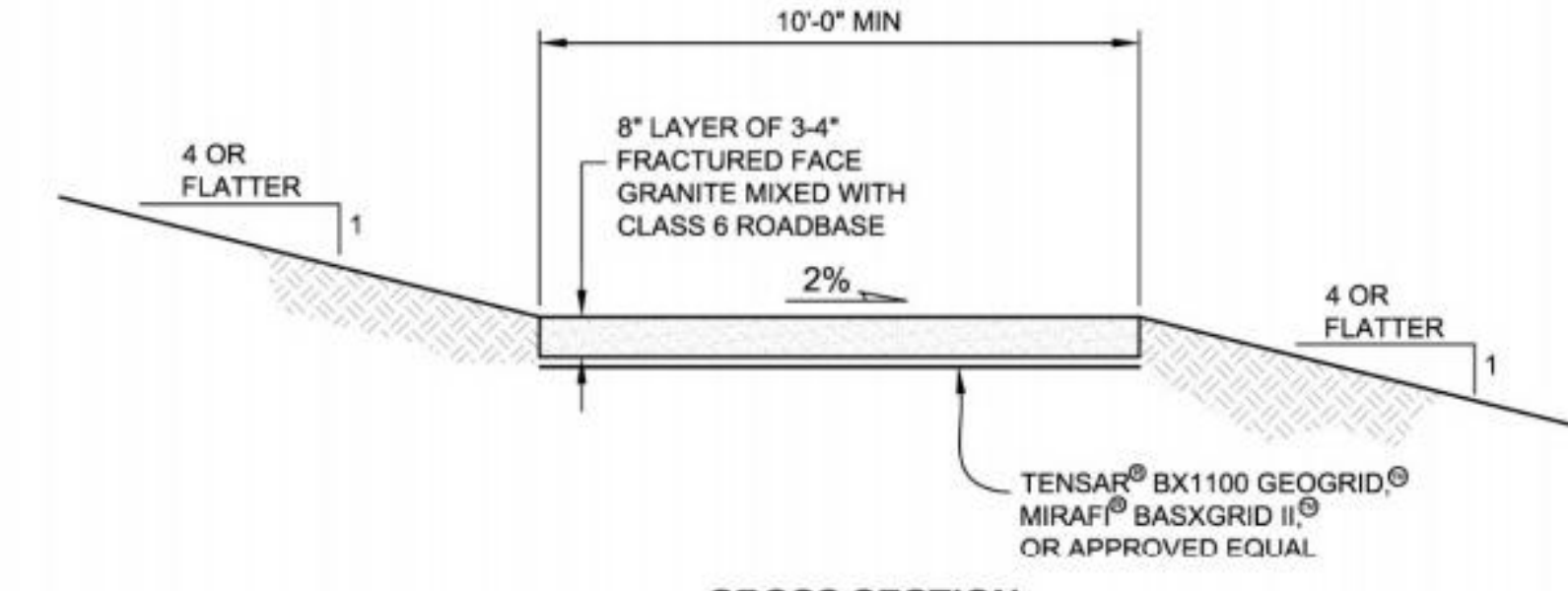
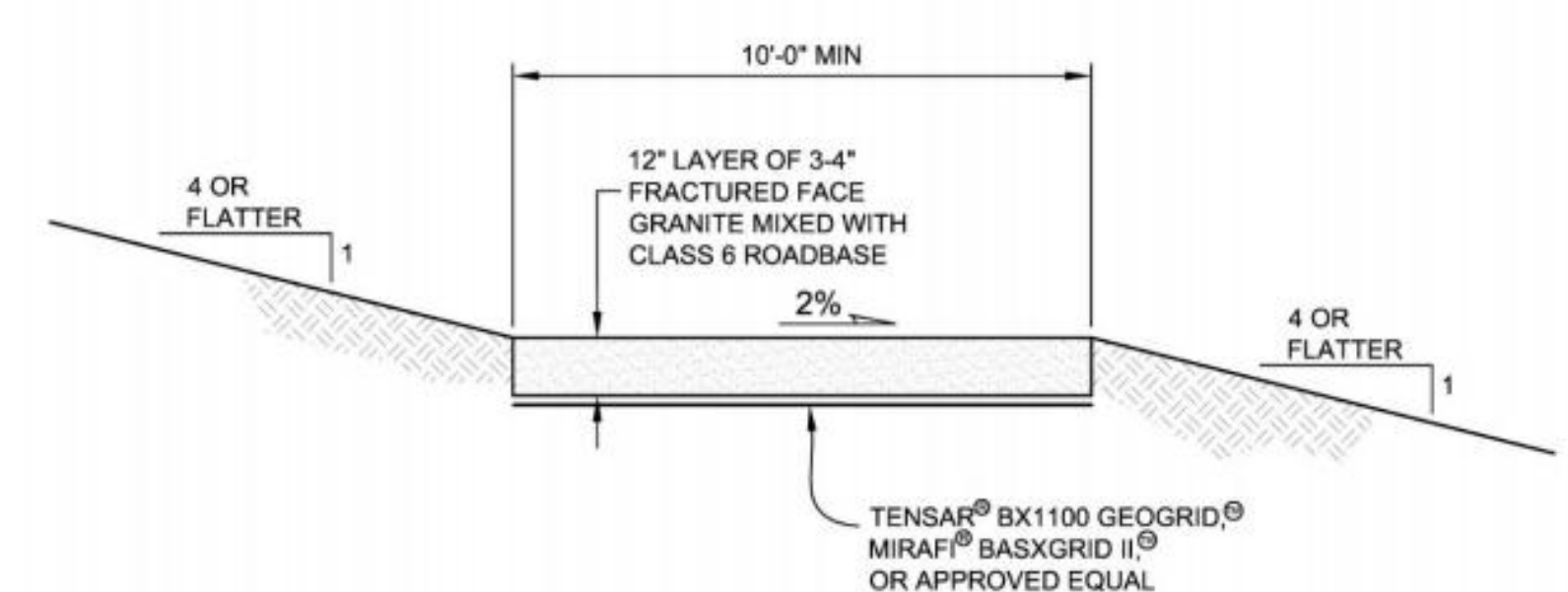
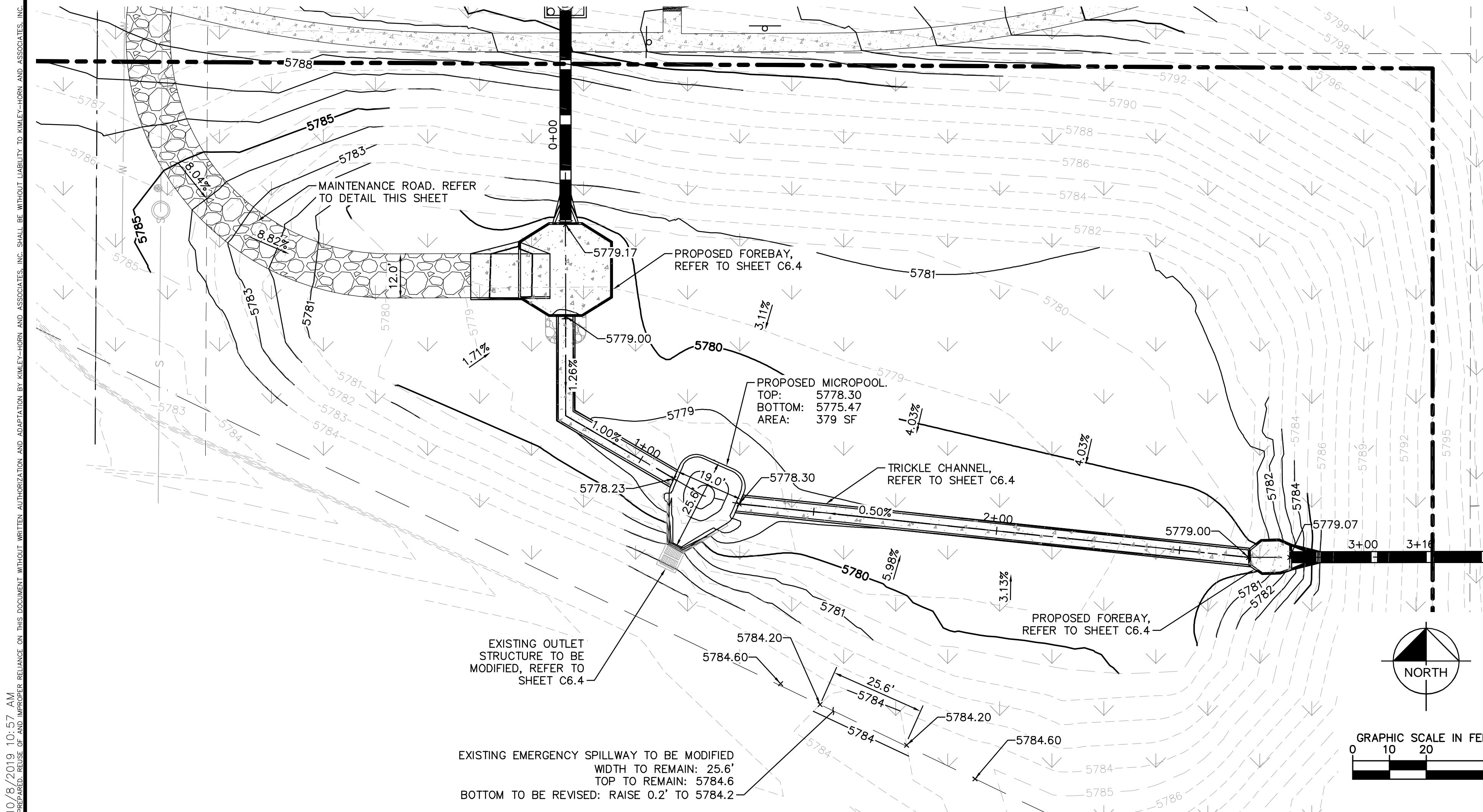

MAINTENANCE ROAD DETAILS
N.T.S.

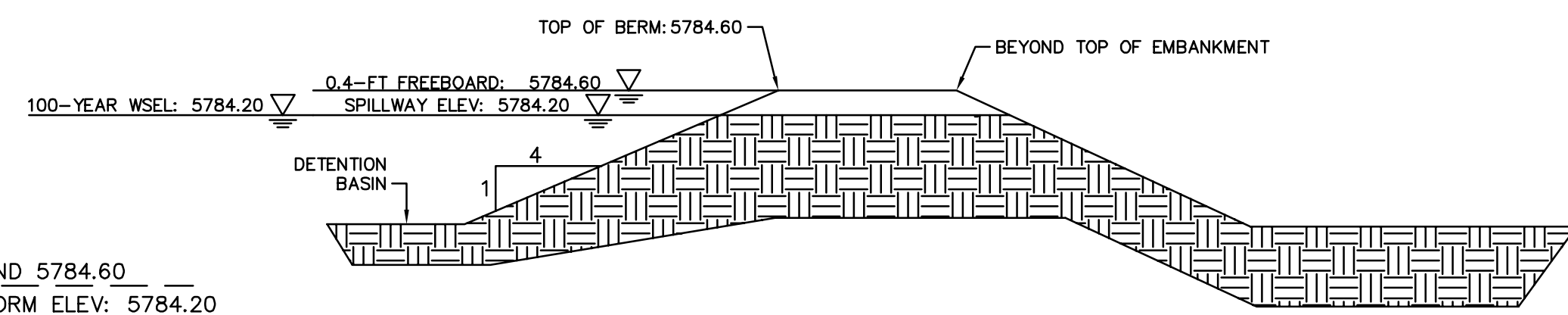

MODIFIED EXISTING EMERGENCY SPILLWAY DETAIL
N.T.S.

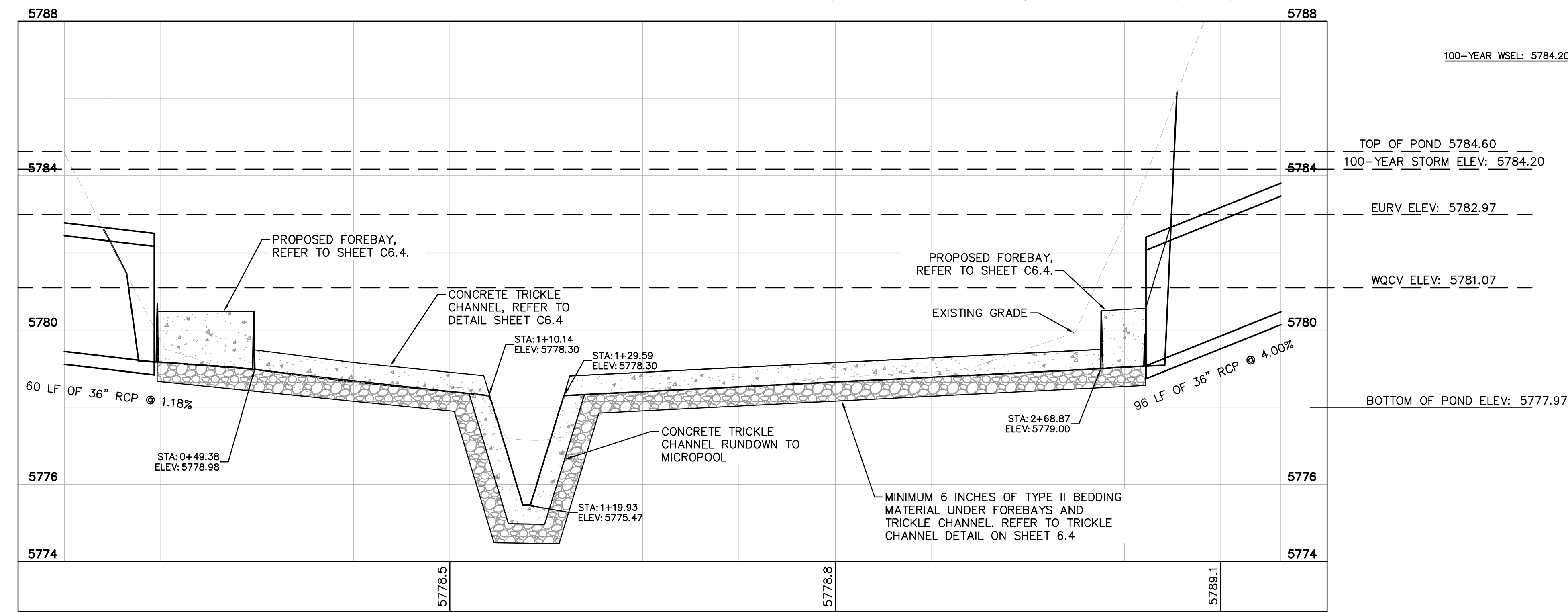

POND PROFILE
HORIZONTAL SCALE: 1" = 20'
VERTICAL SCALE: 1" = 2'

NO.	REVISION	BY	DATE	APPR

Kimley»Horn
2020 KIMLEY-HORN AND ASSOCIATES, INC.
4582 South Ulster Street, Suite 1500
Denver, Colorado 80237 (303) 228-2300

DESIGNED BY: DLS
DRAWN BY: JRK
CHECKED BY: DLS
DATE: 04/24/20

PARKER AND PINE FILING 1
PARKER, CO
CONSTRUCTION DOCUMENTS
POND PLANS AND PROFILE

PRELIMINARY
FOR REVIEW ONLY
NOT FOR
CONSTRUCTION
Kimley»Horn
Kimley-Horn and Associates, Inc.

PROJECT NO.
096502001

DRAWING NAME
096502001ST_DET

C6.3



C:\Users\jkr\OneDrive\Desktop\Projects\096502001\ST_DET.dwg - K:\Projects\096502001\04_24_20_10_47_AM.dwg - 10/19/2019 10:47 AM
THIS DOCUMENT, TOGETHER WITH ALL CONCEPTS AND DESIGN PRESENTED HEREIN, IS AN INSTRUMENT OF SERVICE. IT IS HEREBY AGREED THAT THE DESIGNER SHALL BE WITHOUT LIABILITY TO KIMLEY-HORN AND ASSOCIATES, INC. IN THE EVENT OF ANY SUCH INSTRUMENT OF SERVICE.

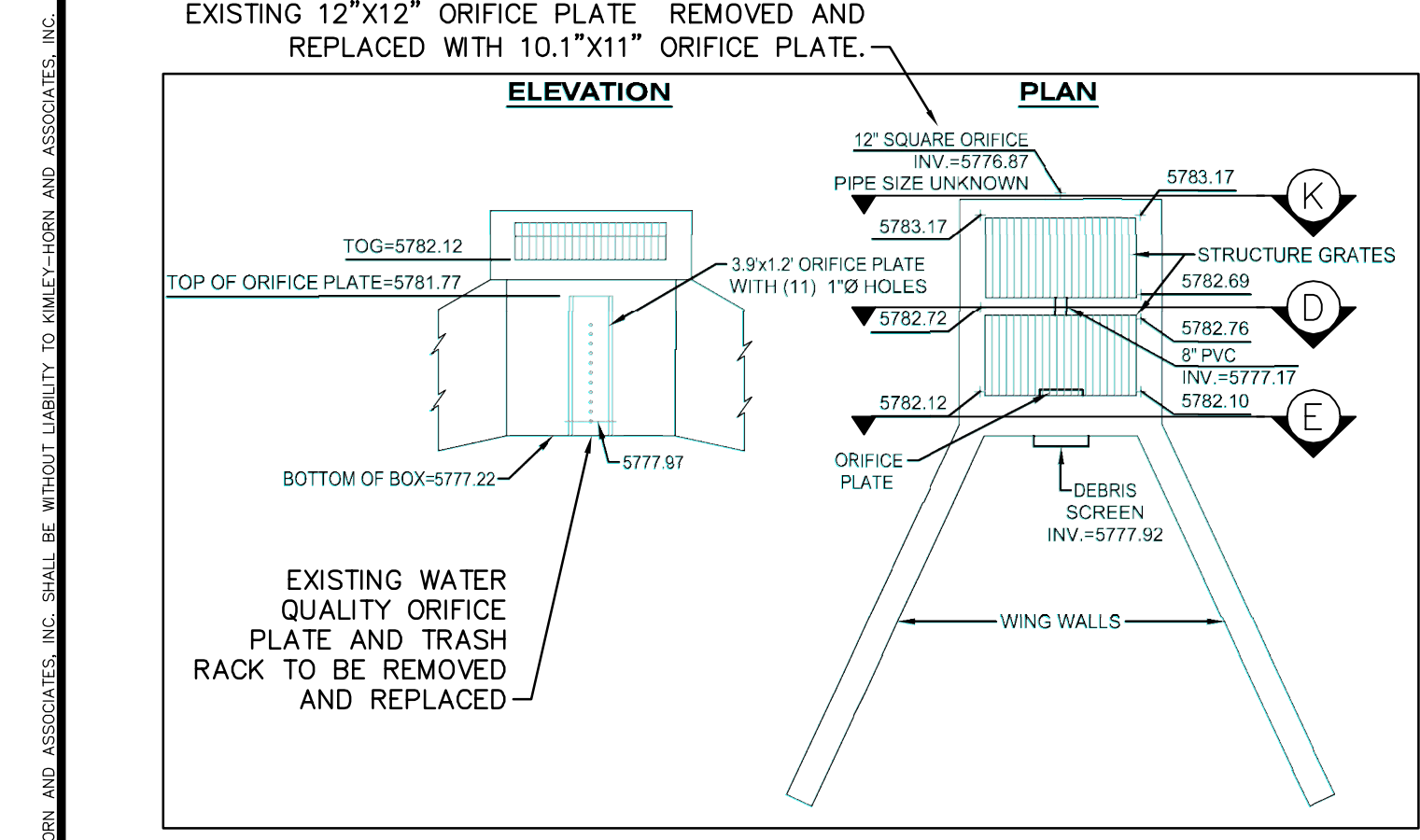

J EXISTING OUTLET STRUCTURE
SCALE: 1" = 5'

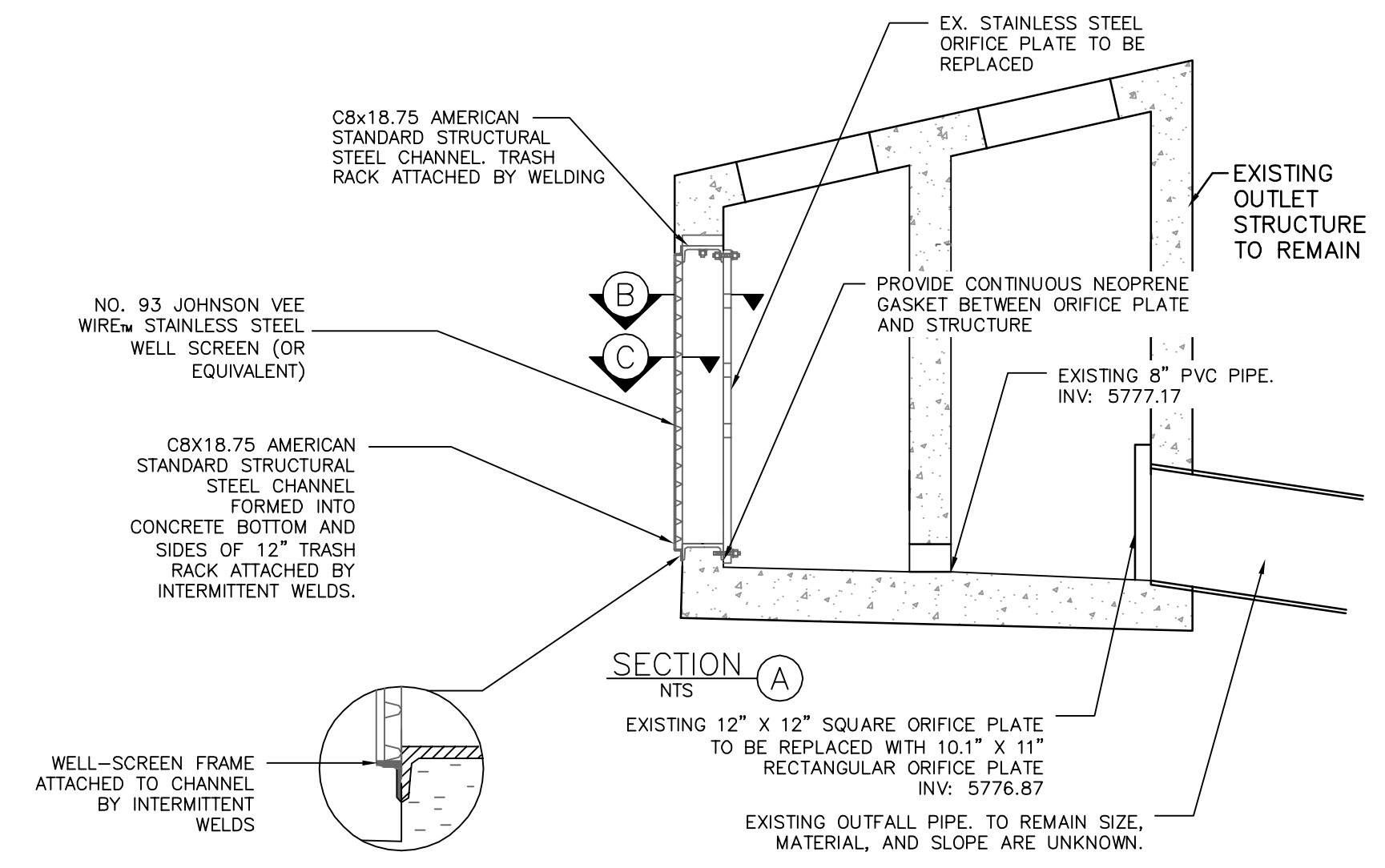

A SECTION
N.T.S.

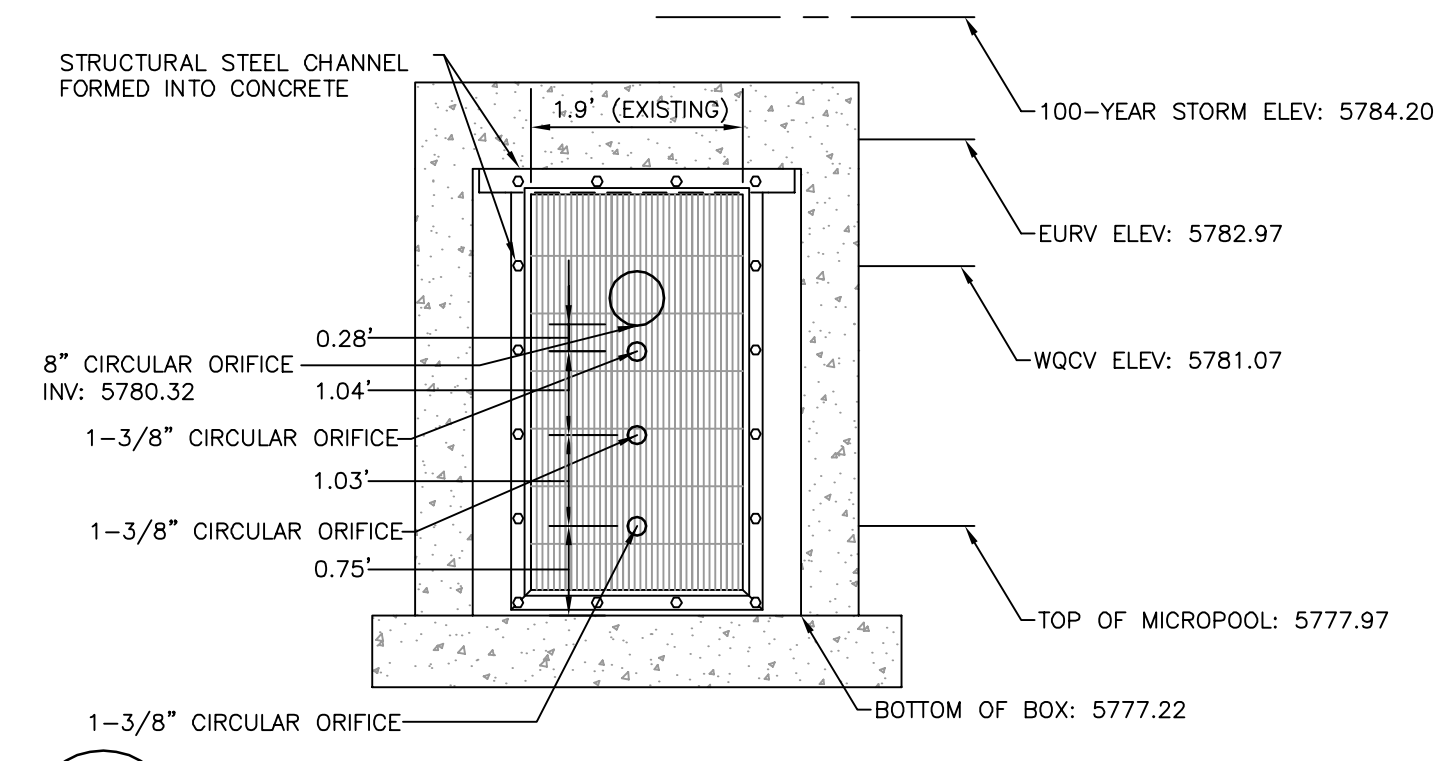

E ORIFICE PLATE AND TRASH RACK DETAIL
N.T.S.

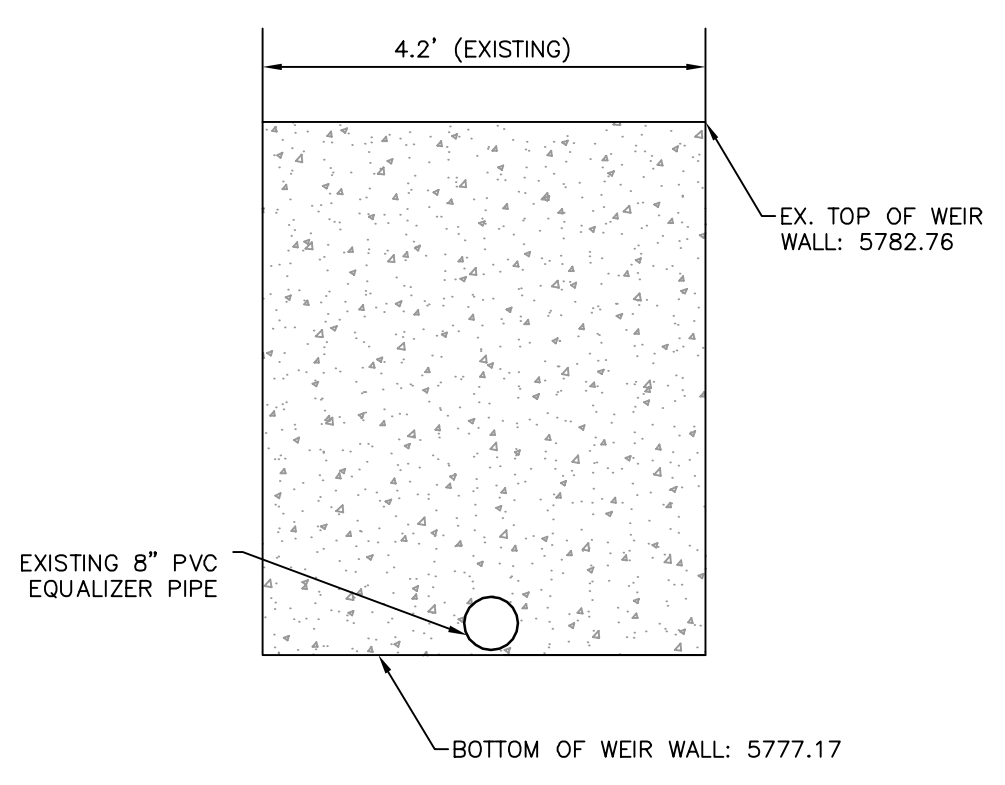

D EXISTING INTERNAL WEIR TO REMAIN
N.T.S.

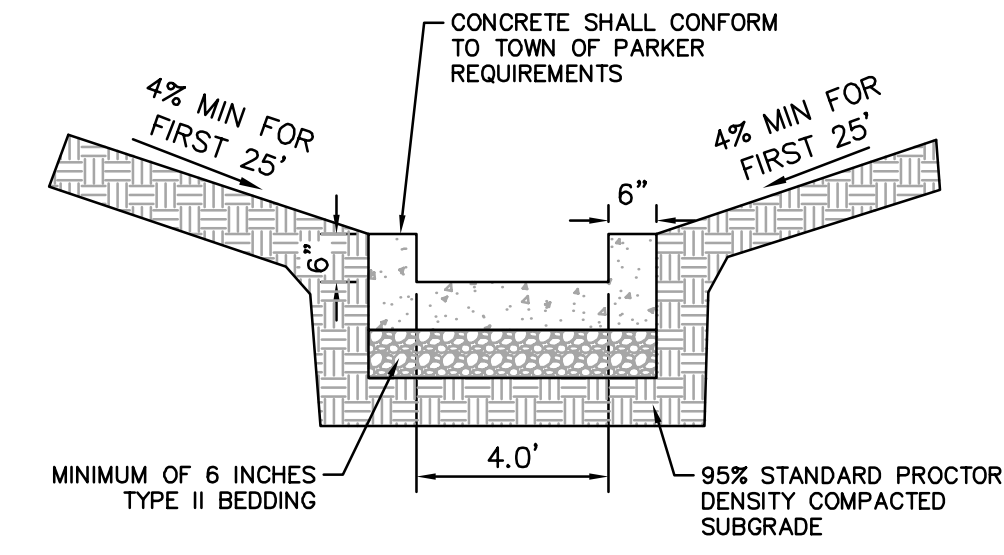

G TRICKLE CHANNEL
N.T.S.

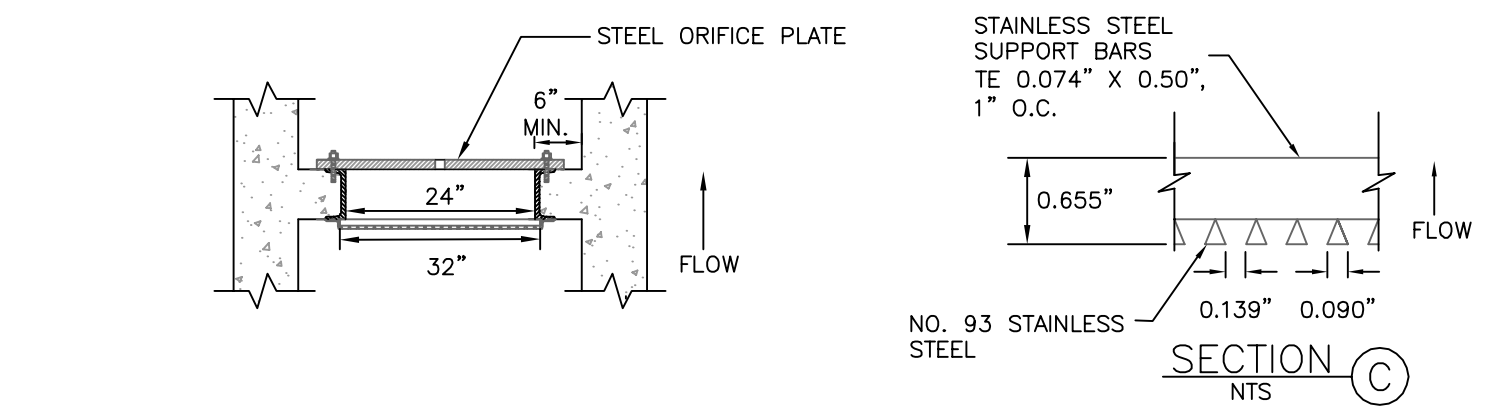

F EXISTING OUTLET STRUCTURE WITH MODIFIED ORIFICE PLATE
N.T.S.

- ORIFICE PLATE NOTES:**
1. PROVIDE CONTINUOUS NEOPRENE GASKET MATERIAL BETWEEN THE ORIFICE PLATE AND THE CONCRETE.
 2. BOLT PLATE TO CONCRETE 12" MAX ON CENTER.
- EURV AND WQCV TRASH RACKS**
1. WELL-SCREEN TRASH RACKS SHALL BE STAINLESS STEEL AND SHALL BE ATTACHED BY INTERMITTENT WELDS ALONG THE EDGE OF THE MOUNTING FRAME.
 2. BAR GATE TRASH RACKS SHALL BE ALUMINUM AND SHALL BE BOLTED USING STAINLESS STEEL HARDWARE.
 3. TRASH RACK OPEN AREAS ARE FOR SPECIFIED TRASH RACK MATERIALS. TOTAL TRASH RACK SIZE MAY NEED TO BE ADJUSTED FOR MATERIALS HAVING DIFFERENT OPEN AREA/GROSS AREA RATIO.
 4. STRUCTURAL DESIGN OF TRASH RACKS SHALL BE BASED ON FULL HYDROSTATIC HEAD WITH ZERO HEAD DOWNSTREAM OF THE RACK.

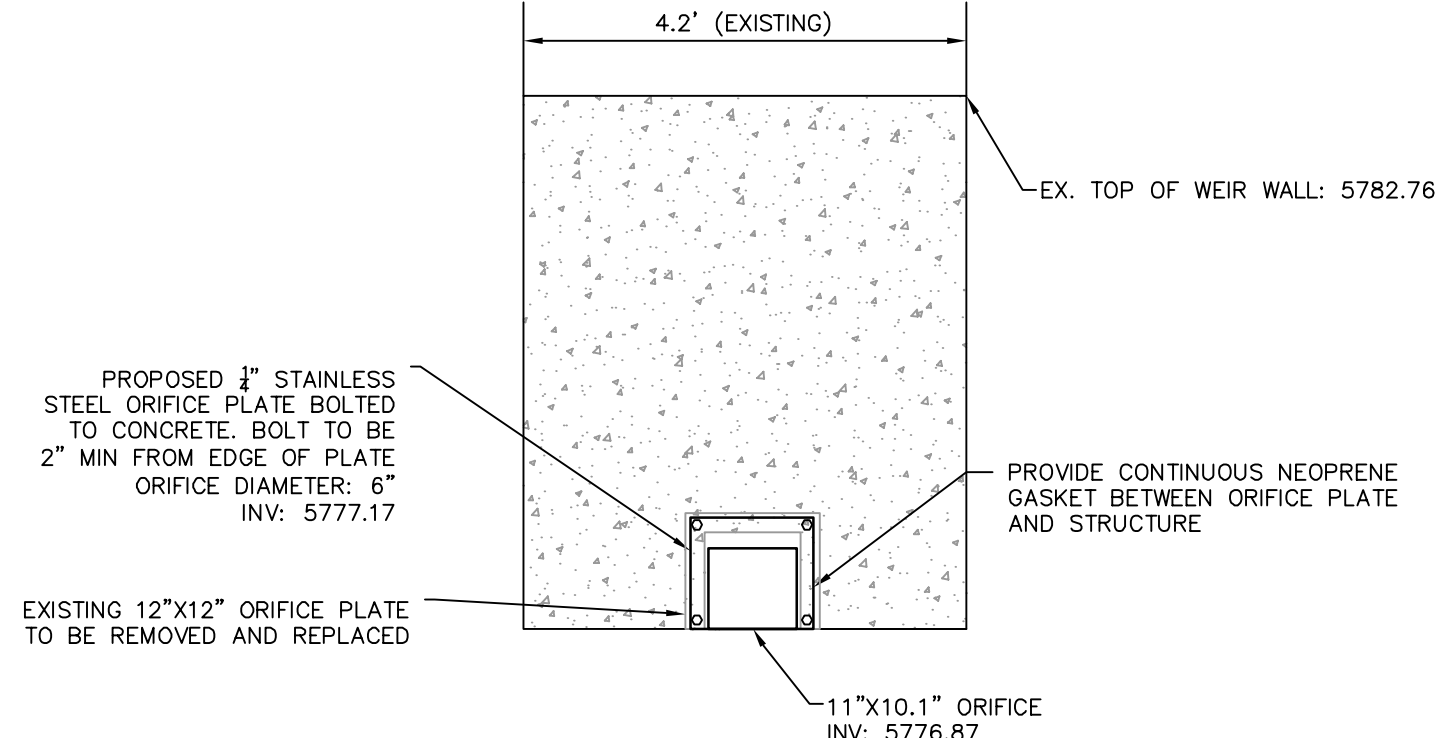

K MODIFIED ORIFICE PLATE
N.T.S.

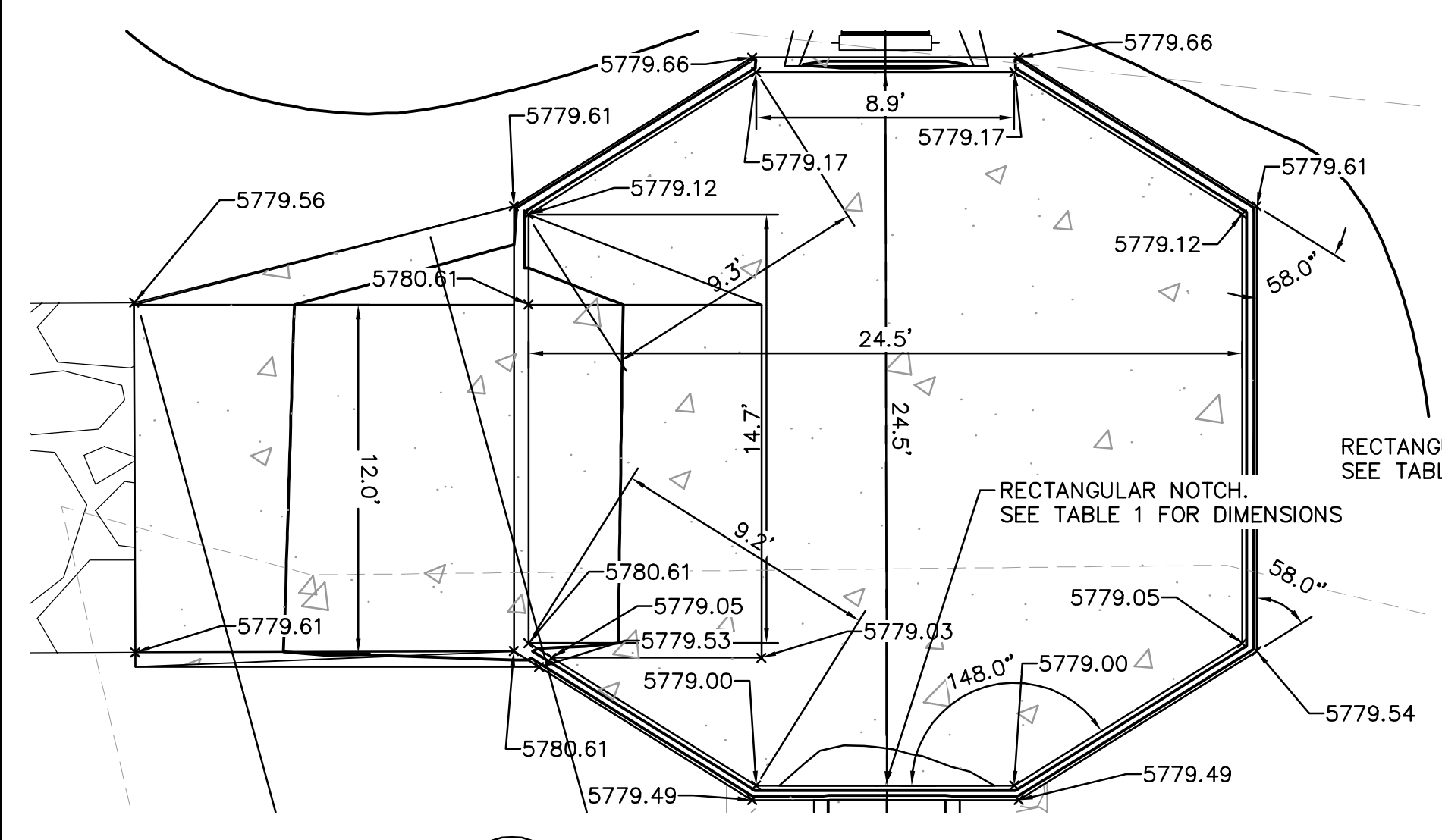

H FOREBAY WEST
1" = 5'

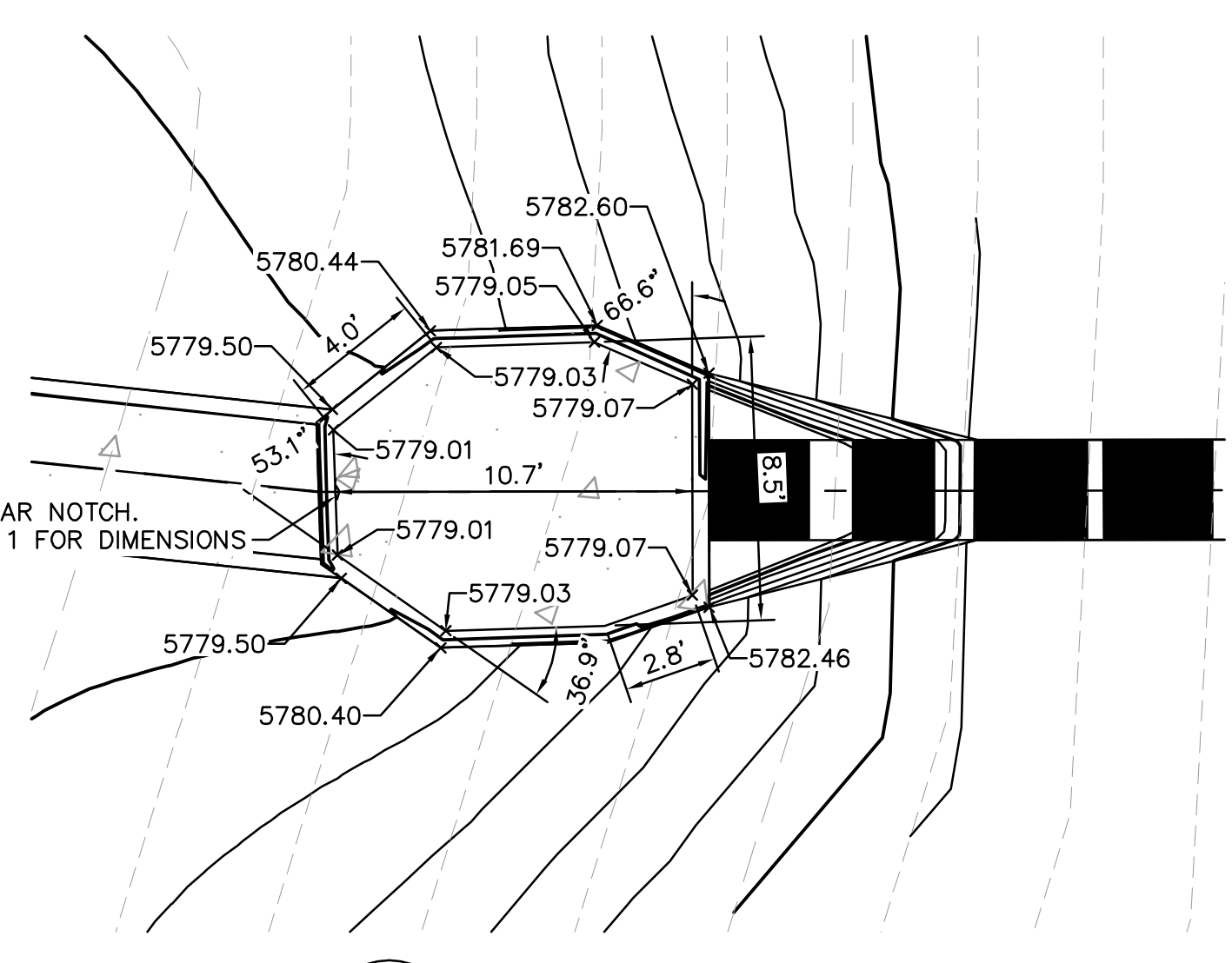

I FOREBAY EAST
1" = 5'

Forebay ID	WATERSHED AREA (AC)	WQCV (CF)	REQUIRED VOLUME (CF)	FOREBAY SIZE (SF)	REQUIRED HEIGHT (INCHES)	PROVIDED HEIGHT (INCHES)	Q ₁₀₀ (cfs)	REQUIRED RELEASE RATE (cfs)	REQUIRED NOTCH WIDTH (INCHES)	ACTUAL NOTCH WIDTH (INCHES)	ACTUAL RELEASE RATE (cfs)
West	13.94	14,295	286	523	6.6	18.0	119.14	2.38	5.5	5.5	2.53
East	2.22	2,277	46	80	6.8	18.0	16.06	0.32	0.75	0.8	0.36

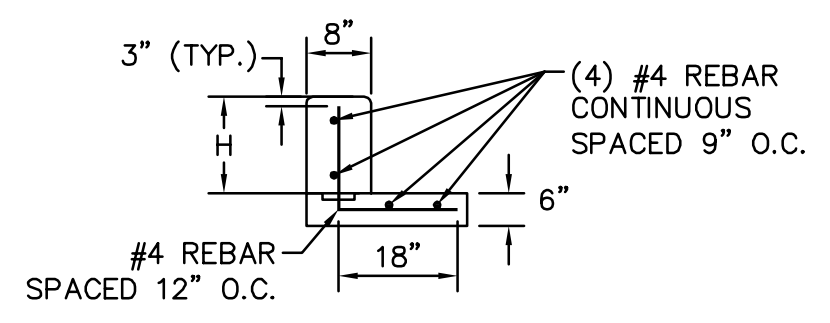

N FOREBAY WALL SECTION TYPICAL DETAIL
N.T.S.

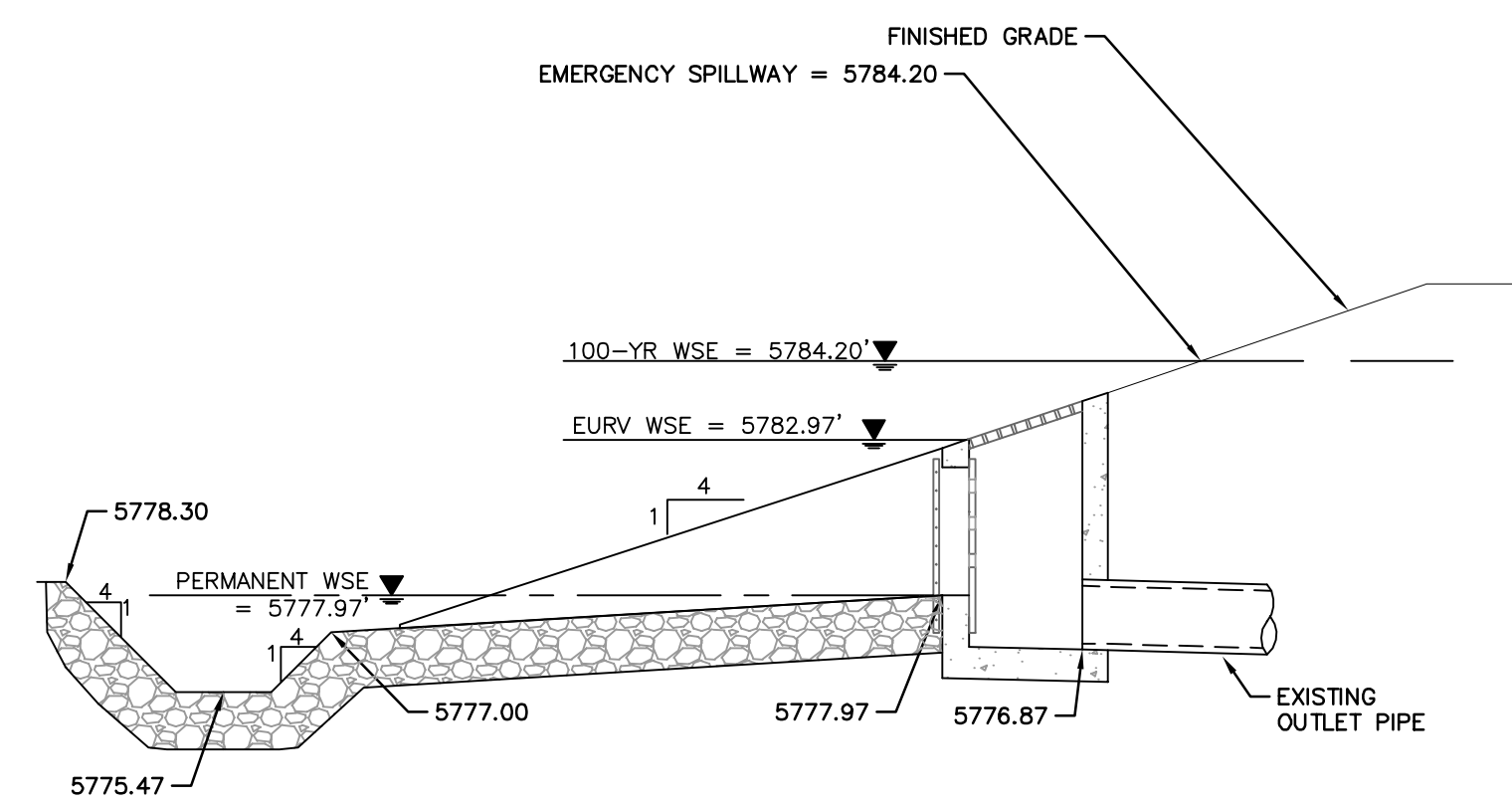

M MICROPOL
N.T.S.

L FOREBAY NOTCH DETAIL
N.T.S.

C:\Users\jkr\OneDrive\Desktop\Projects & Files\Misc\Use\CADD\Plots\Sheet\096502001ST_DET.dwg - K:\Projects - Job: 10/9/2019 10:47 AM. THIS DOCUMENT, TOGETHER WITH ALL ATTACHED FILES, IS THE PROPERTY OF KIMLEY-HORN AND ASSOCIATES, INC. IT IS TO BE USED ONLY FOR THE PROJECT AND SITE SPECIFICALLY IDENTIFIED HEREIN. ANY REUSE OR MODIFICATION OF THIS DOCUMENT WITHOUT WRITTEN AUTHORIZATION AND ADAPTATION BY KIMLEY-HORN AND ASSOCIATES, INC. SHALL BE WITHOUT LIABILITY TO KIMLEY-HORN AND ASSOCIATES, INC.

NO.	REVISION	BY	DATE	APPR

Kimley-Horn
2020 KIMLEY-HORN AND ASSOCIATES, INC.
4582 South Ulster Street, Suite 1500
Denver, Colorado 80237 (303) 228-2300

DESIGNED BY: DLS
DRAWN BY: JRK
CHECKED BY: DLS
DATE: 04/24/20

PARKER AND PINE FILING 1
PARKER, CO
CONSTRUCTION DOCUMENTS
POND DETAILS

PRELIMINARY
FOR REVIEW ONLY
NOT FOR CONSTRUCTION
Kimley-Horn
Kimley-Horn and Associates, Inc.

PROJECT NO.
096502001

DRAWING NAME
096502001ST_DET

C6.4

