

CBMP | **DTC**
 CONSTRUCTION BEST MANAGEMENT PRACTICES | 1 OF 2
 Oct. 2013

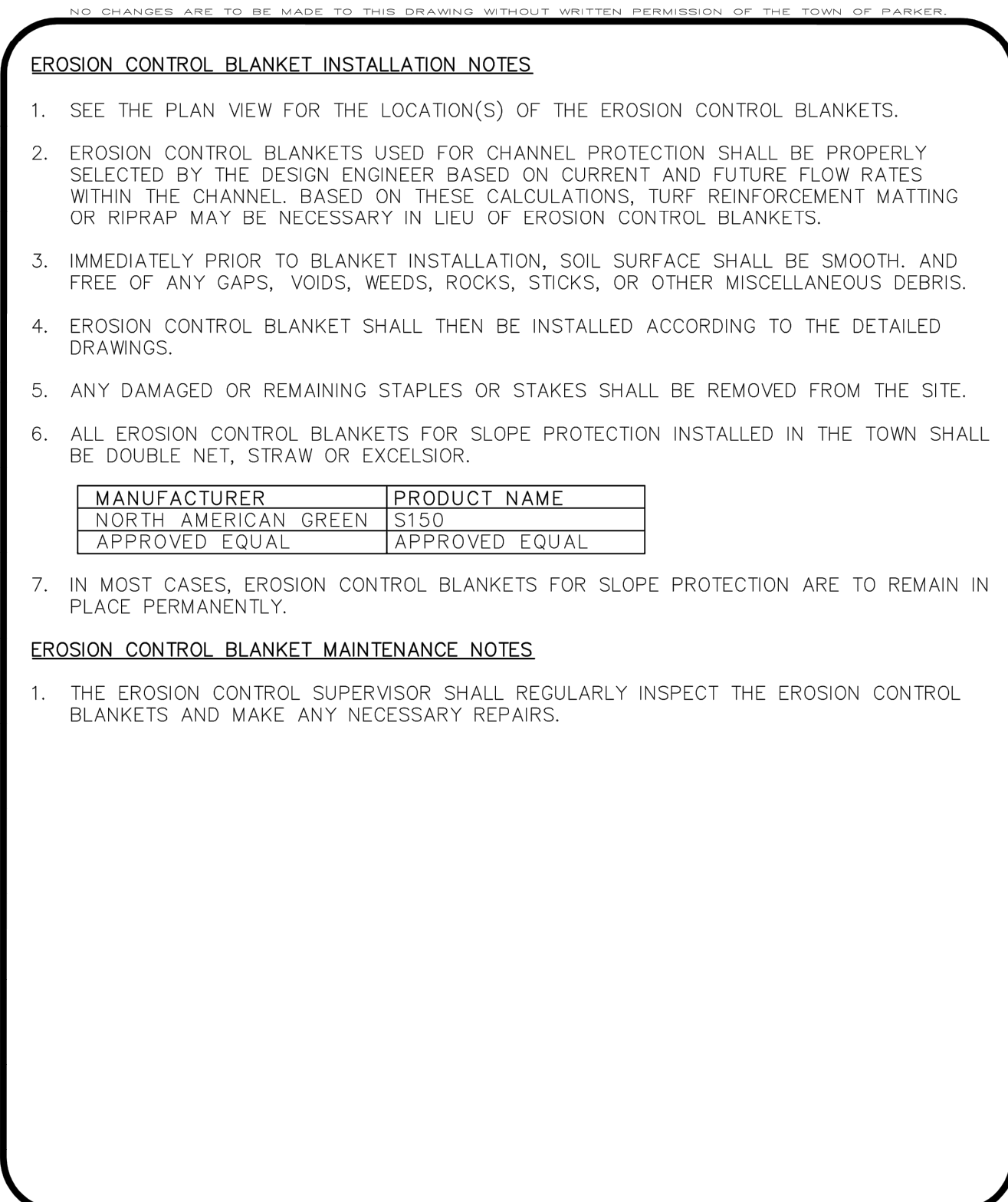

CBMP | **ECB**
 CONSTRUCTION BEST MANAGEMENT PRACTICES | 3 OF 3
 Oct. 2013

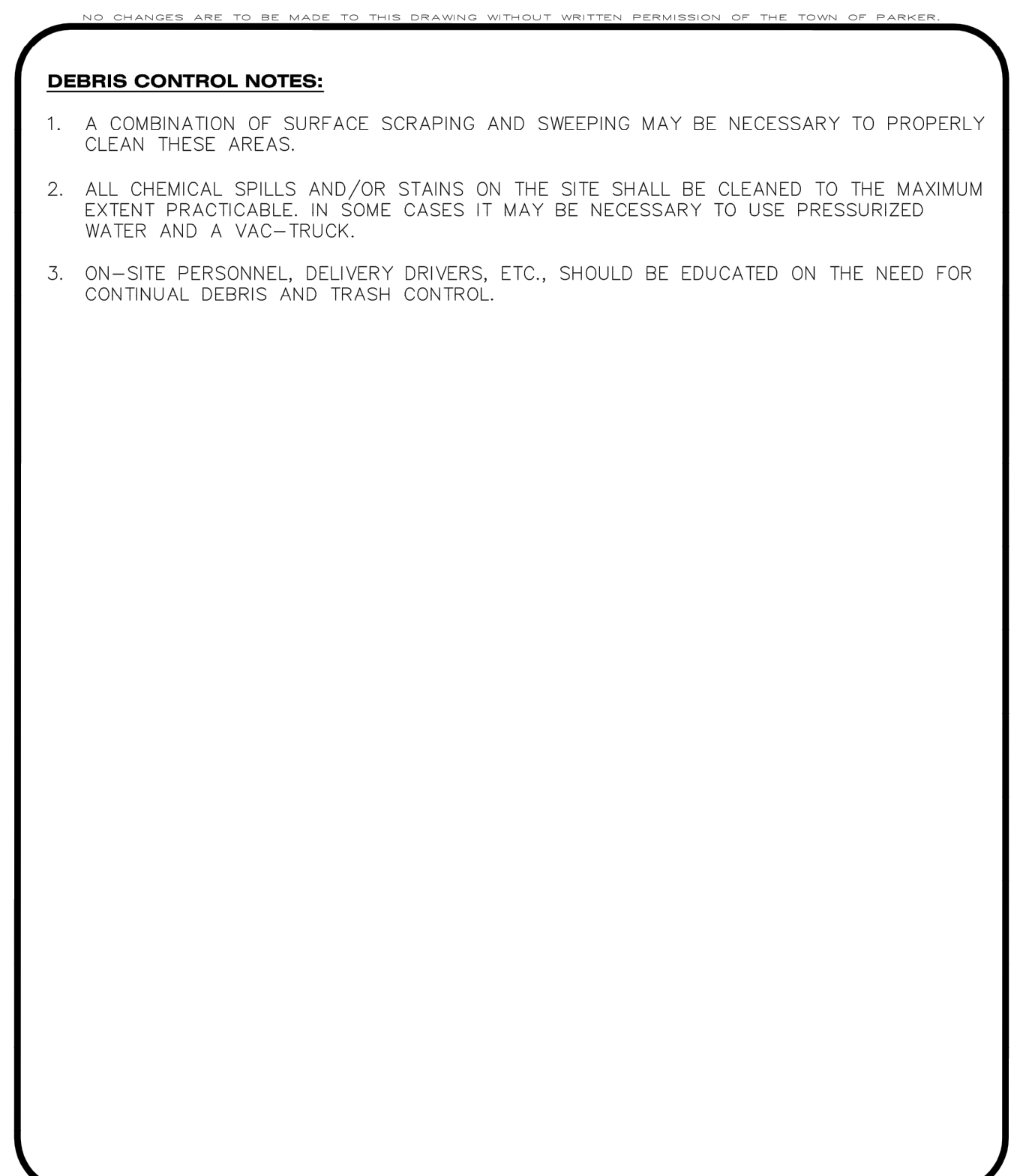

CBMP | **DTC**
 CONSTRUCTION BEST MANAGEMENT PRACTICES | 2 OF 2
 Oct. 2013

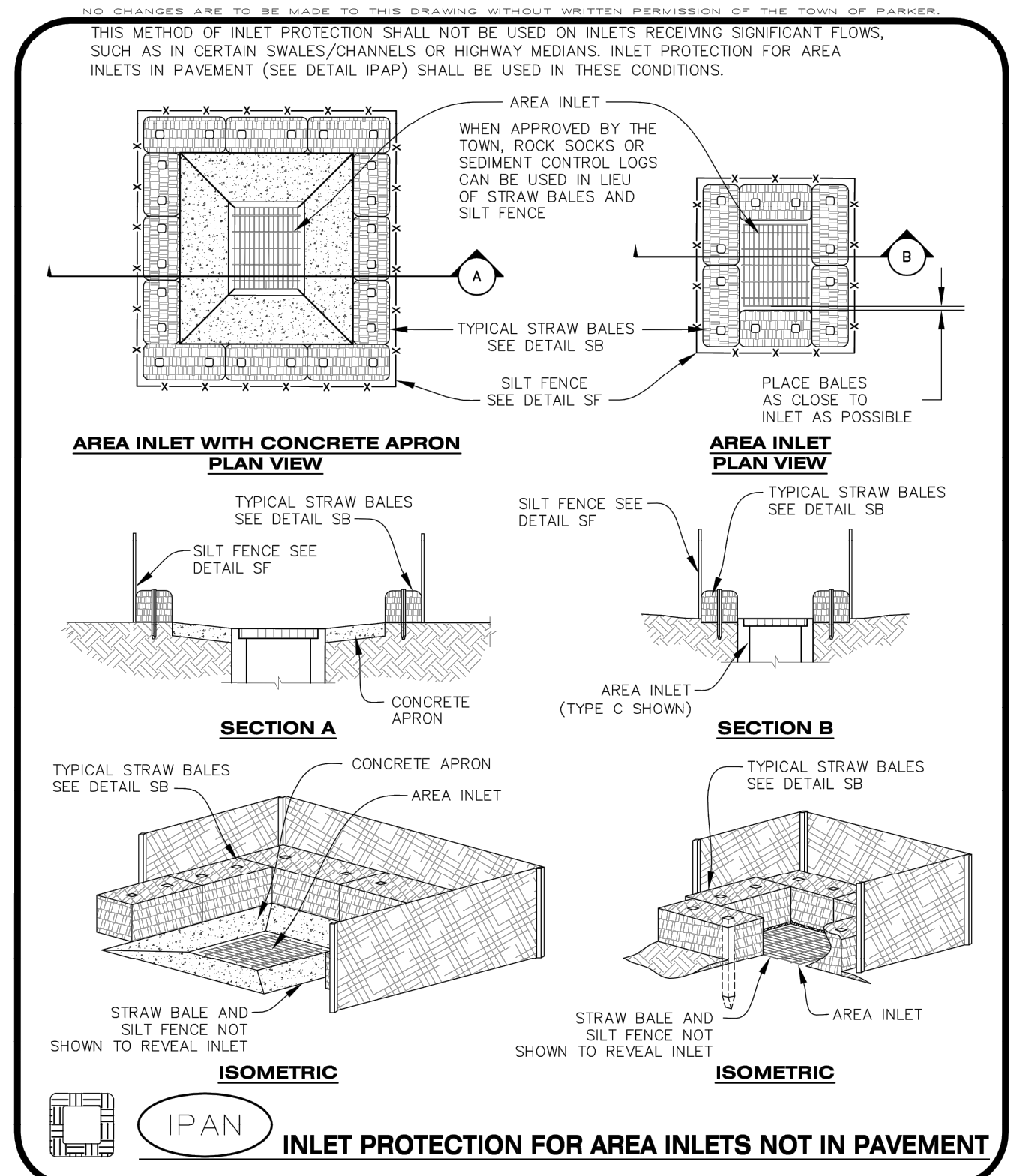

CBMP | **IPAN**
 CONSTRUCTION BEST MANAGEMENT PRACTICES | 1 OF 1
 Oct. 2013

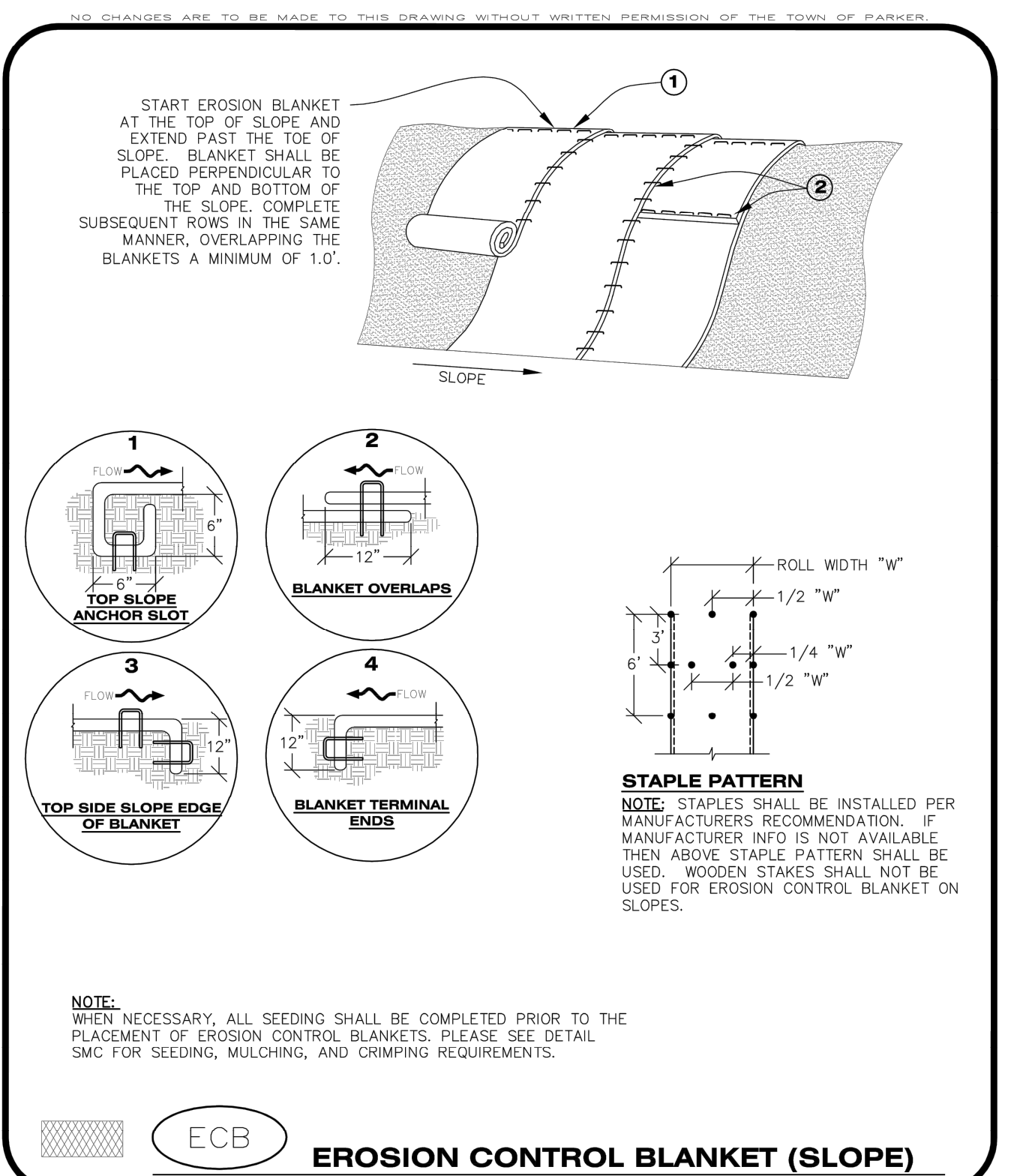

CBMP | **ECB**
 CONSTRUCTION BEST MANAGEMENT PRACTICES | 1 OF 3
 Oct. 2013

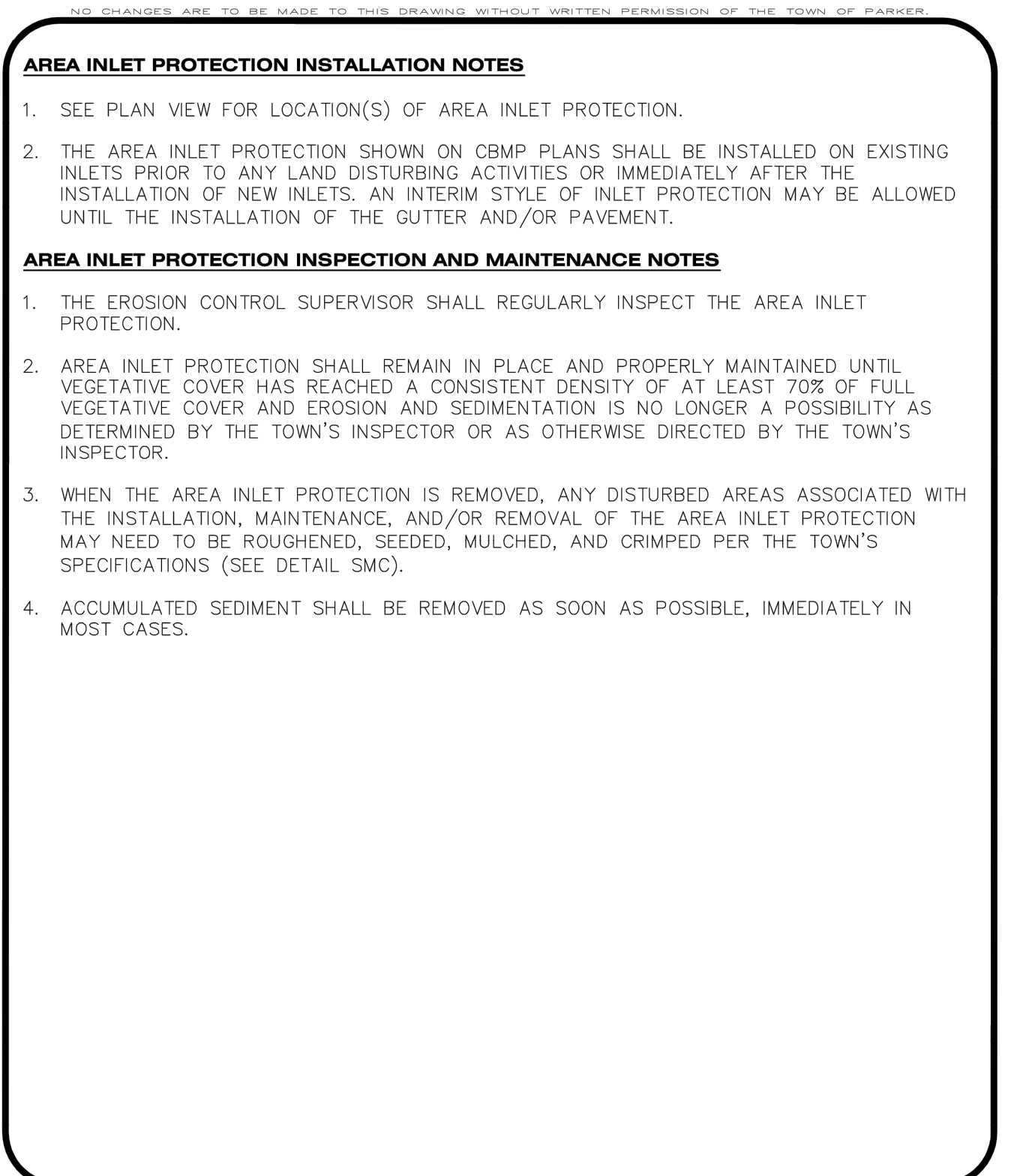

CBMP | **IPA**
 CONSTRUCTION BEST MANAGEMENT PRACTICES | 1 OF 1
 Oct. 2013

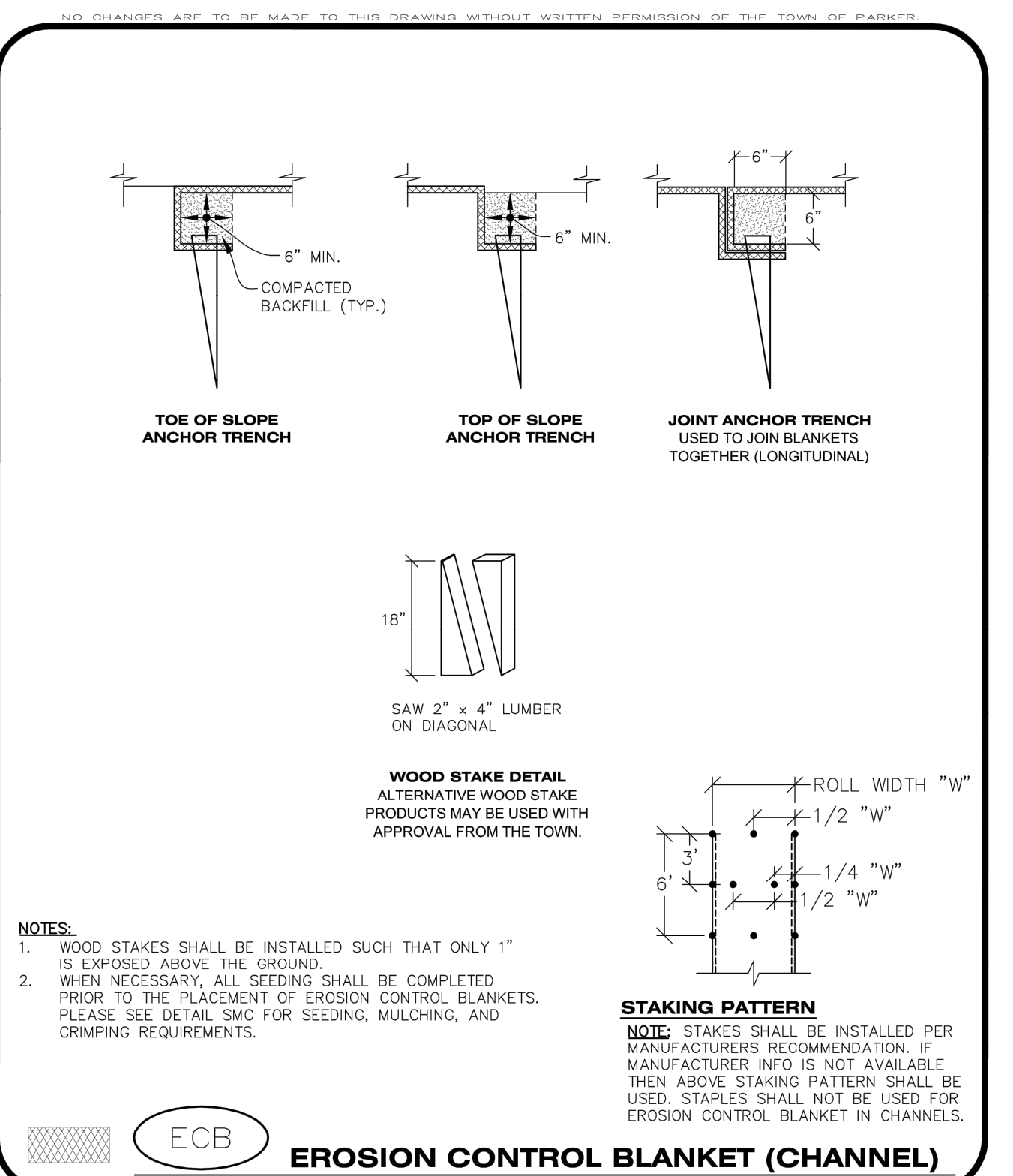

CBMP | **ECB**
 CONSTRUCTION BEST MANAGEMENT PRACTICES | 2 OF 3
 Oct. 2013

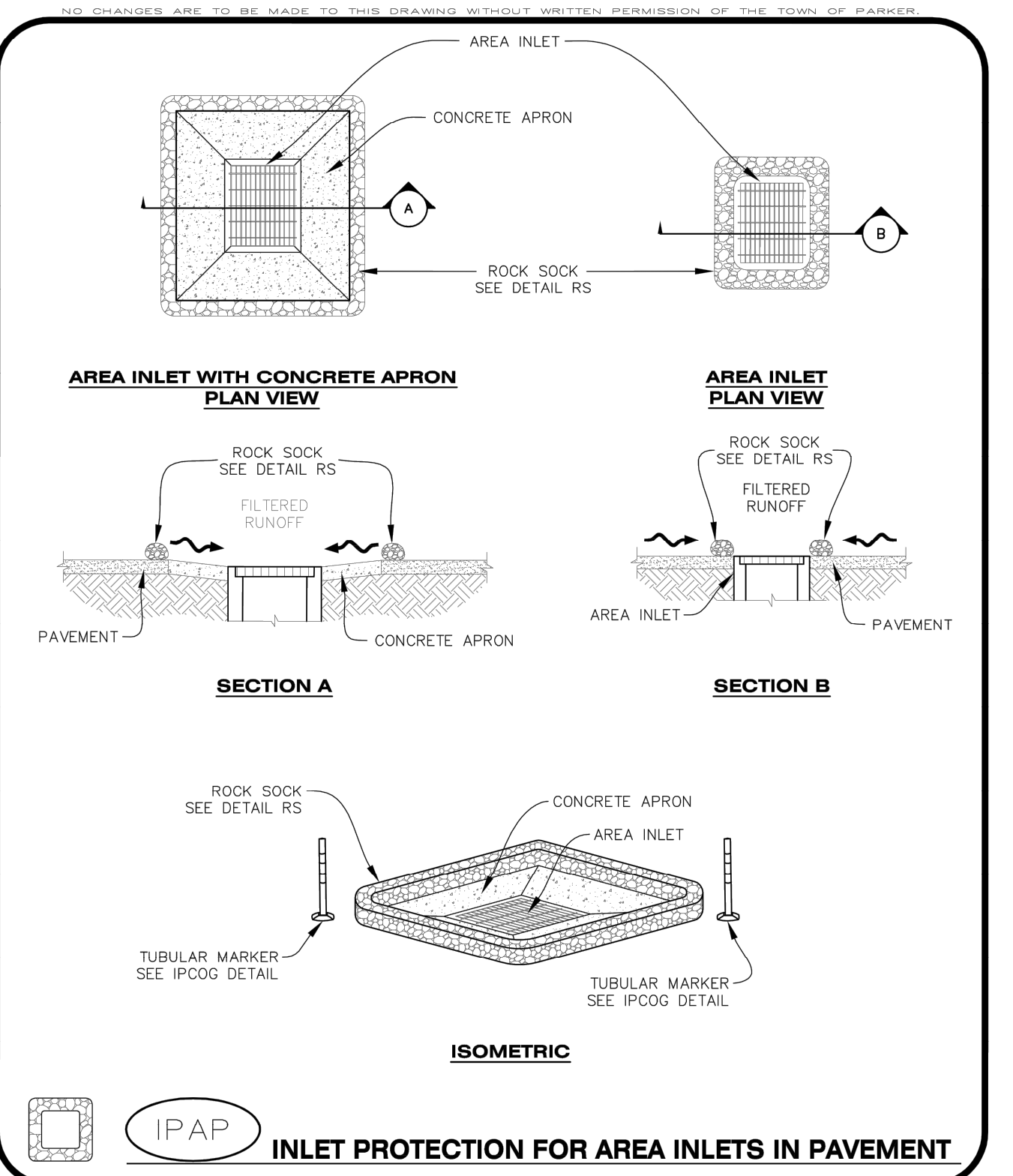

CBMP | **IPAP**
 CONSTRUCTION BEST MANAGEMENT PRACTICES | 1 OF 1
 Oct. 2013



NO.	REVISION	BY	DATE

Kimley»Horn
 2020 KIMLEY-HORN AND ASSOCIATES, INC.
 4582 South Ulster Street, Suite 1500
 Denver, Colorado 80237 (303) 228-2300

DESIGNED BY: DLS
 DRAWN BY: JRK
 CHECKED BY: DLS
 DATE: 04/19/21

PARKER AND PINE FILING NO. 2 LOTS 1-3
 PARKER, CO
 MULTI-FAMILY CONSTRUCTION DOCUMENTS
 CBMP DETAILS

PRELIMINARY
 FOR REVIEW ONLY
 NOT FOR CONSTRUCTION
Kimley»Horn
 Kimley-Horn and Associates, Inc.

PROJECT NO.
 096481002
 DRAWING NAME
 096481002EC_DT
C3.5

10/19/2010 10:57 AM D:\parker\horns\del\civil\096481002 - Parker & Pine\CBMP\Drawings\096481002_EC_DT.dwg User: jrk Date: 10/19/2010 10:57 AM
 This drawing is the property of Kimley-Horn and Associates, Inc. and is loaned to the client for their use only. It is not to be reproduced, copied, or distributed without the written permission of Kimley-Horn and Associates, Inc.

10/19/2016 10:57 AM
 Parker & Pines, Inc. (P&P) is the author of this drawing. The design and construction of the project shall be in accordance with the approved plans and specifications. The design and construction of the project shall be in accordance with the approved plans and specifications. The design and construction of the project shall be in accordance with the approved plans and specifications.

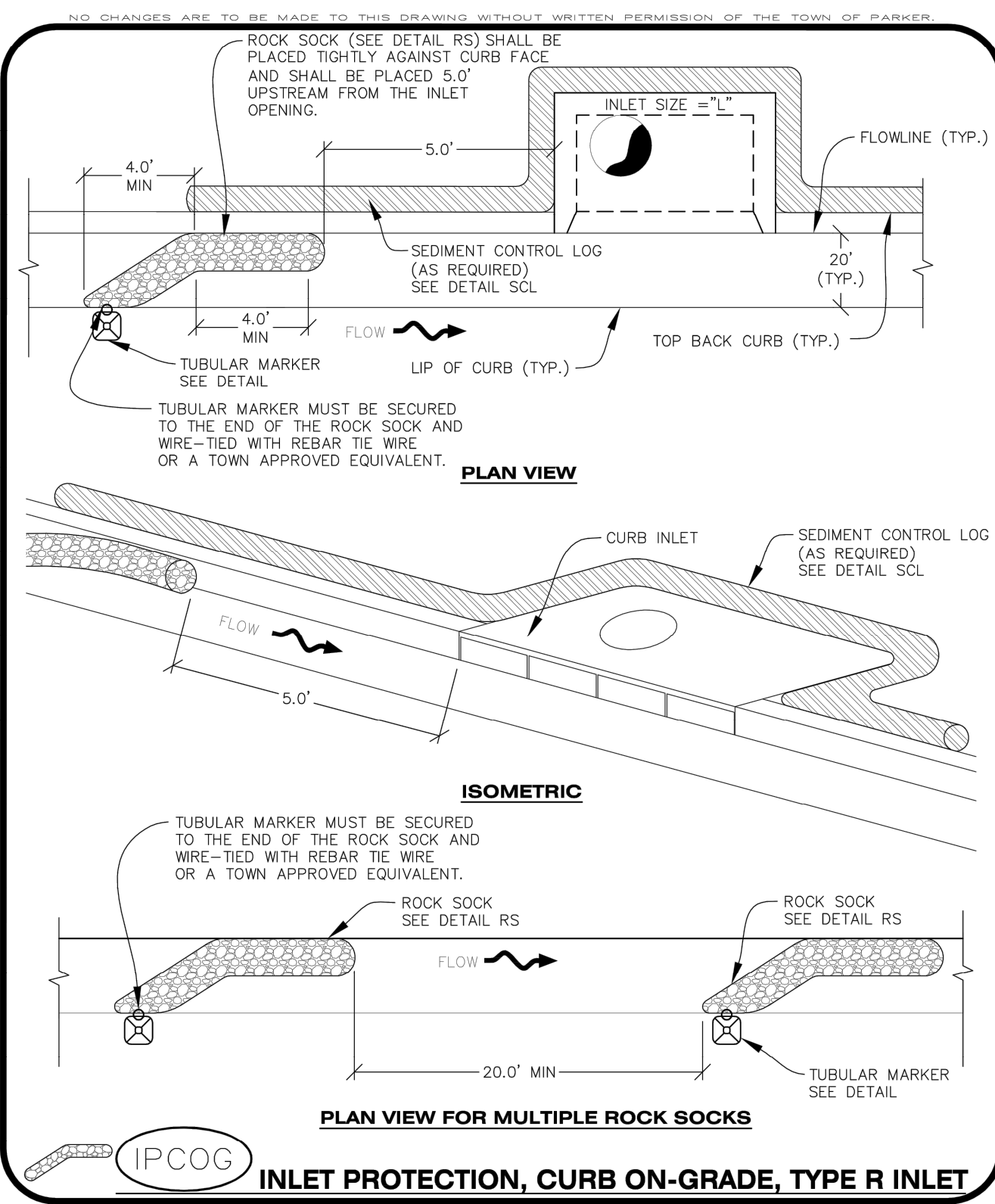

CBMP CONSTRUCTION BEST MANAGEMENT PRACTICES
IPC 1 OF 3
 Oct. 2013

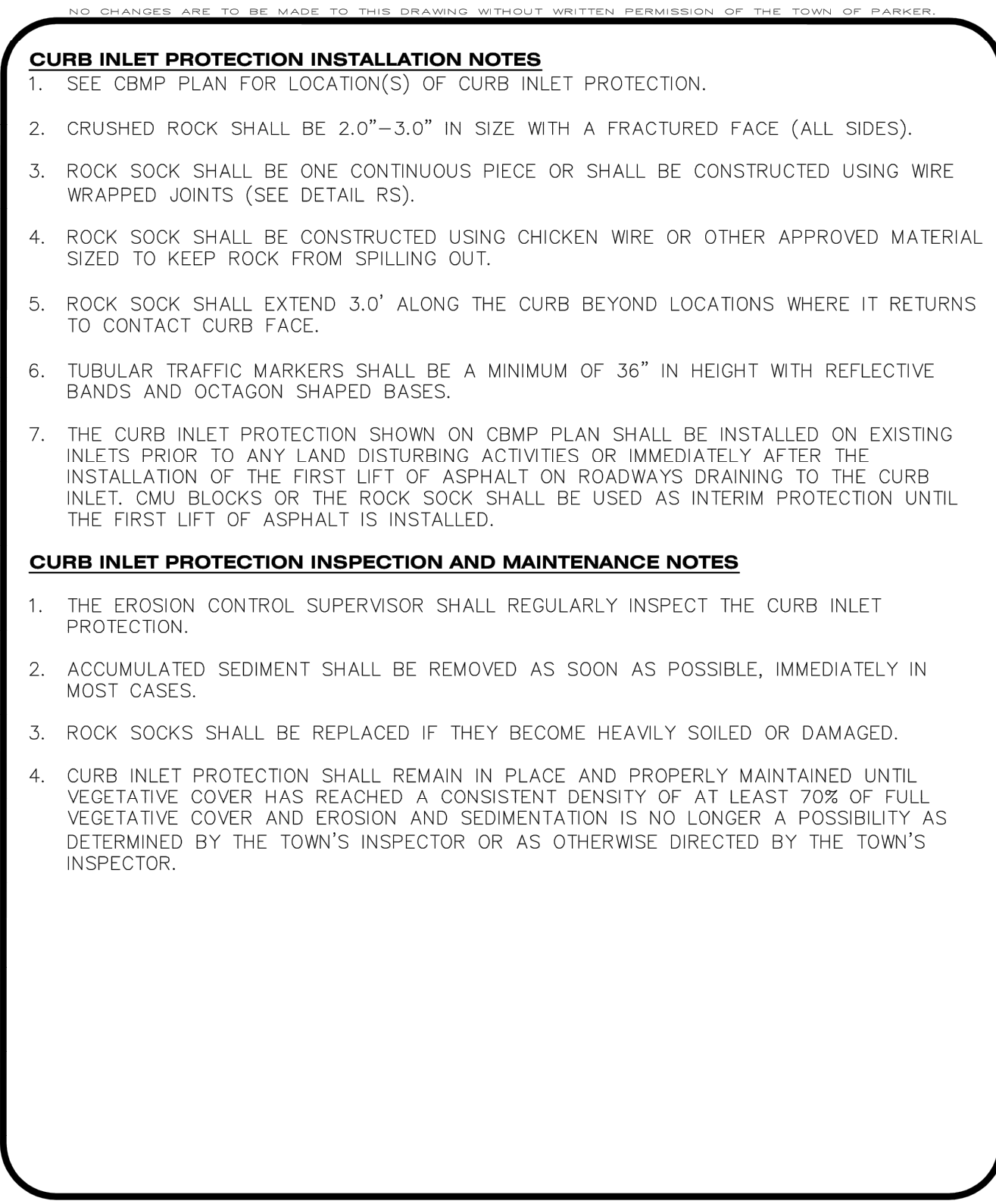

CBMP CONSTRUCTION BEST MANAGEMENT PRACTICES
IPC 2 OF 2
 Oct. 2013

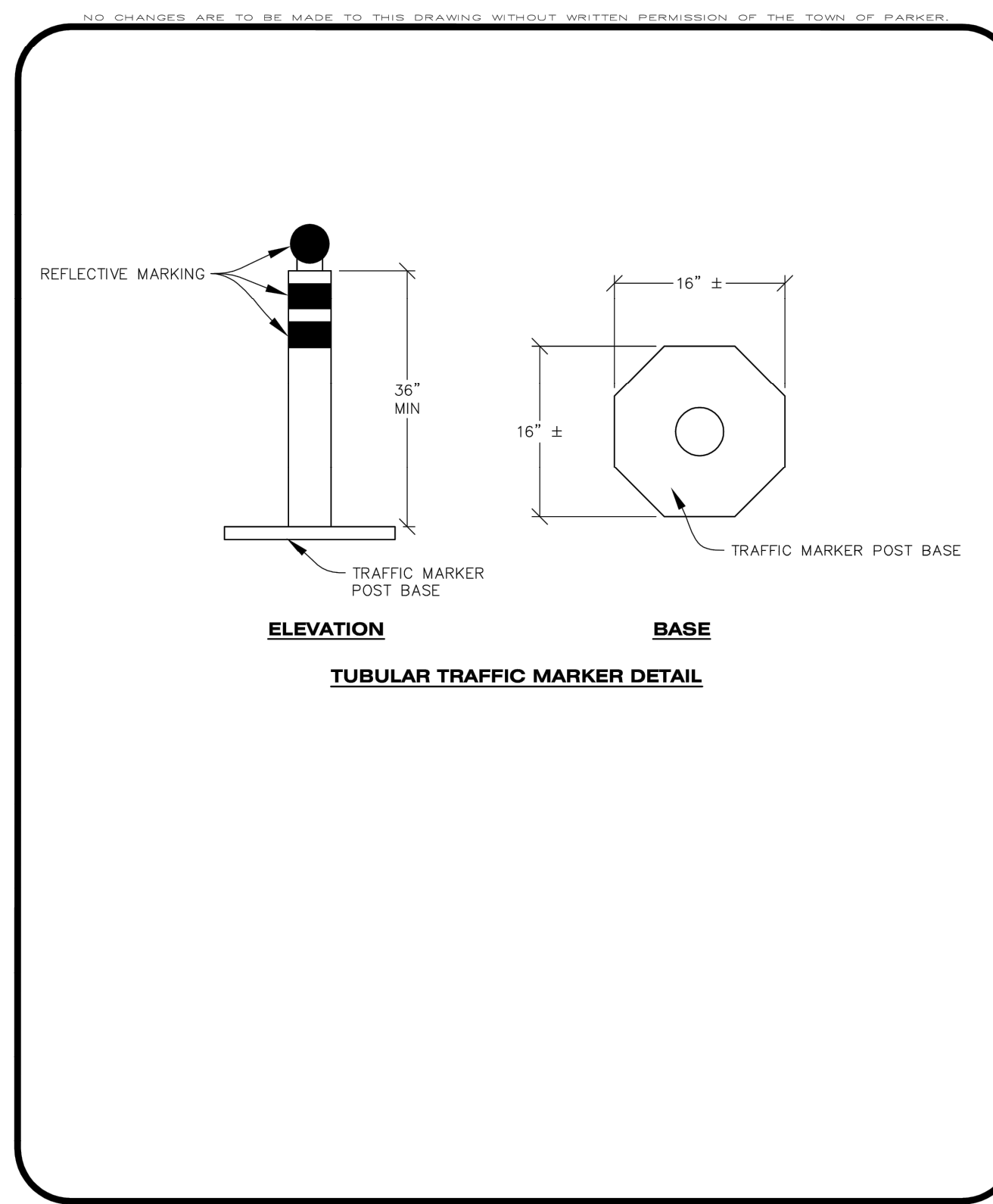

CBMP CONSTRUCTION BEST MANAGEMENT PRACTICES
IPC 2 OF 3
 Oct. 2013

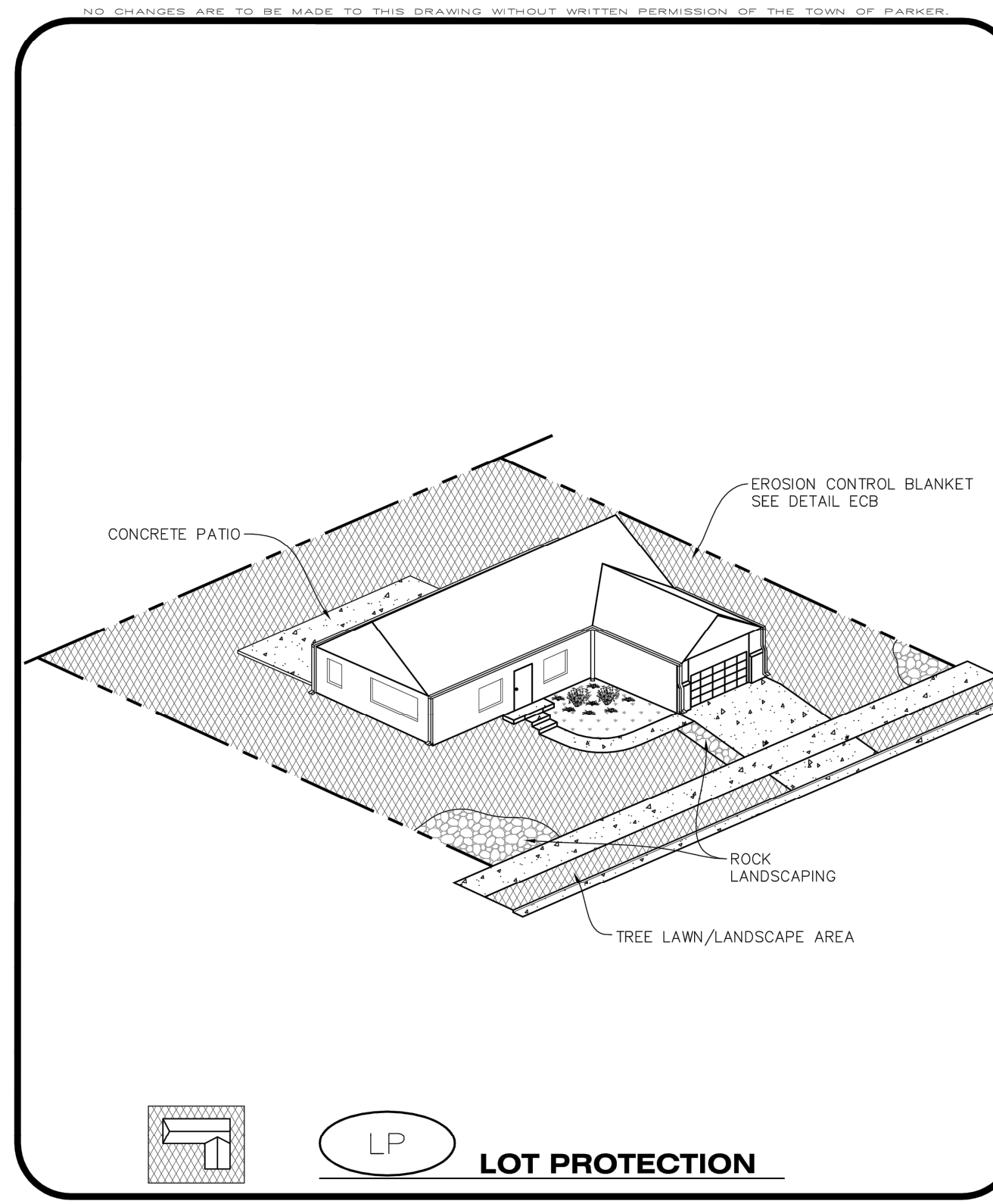

CBMP CONSTRUCTION BEST MANAGEMENT PRACTICES
LP 1 OF 2
 Oct. 2013

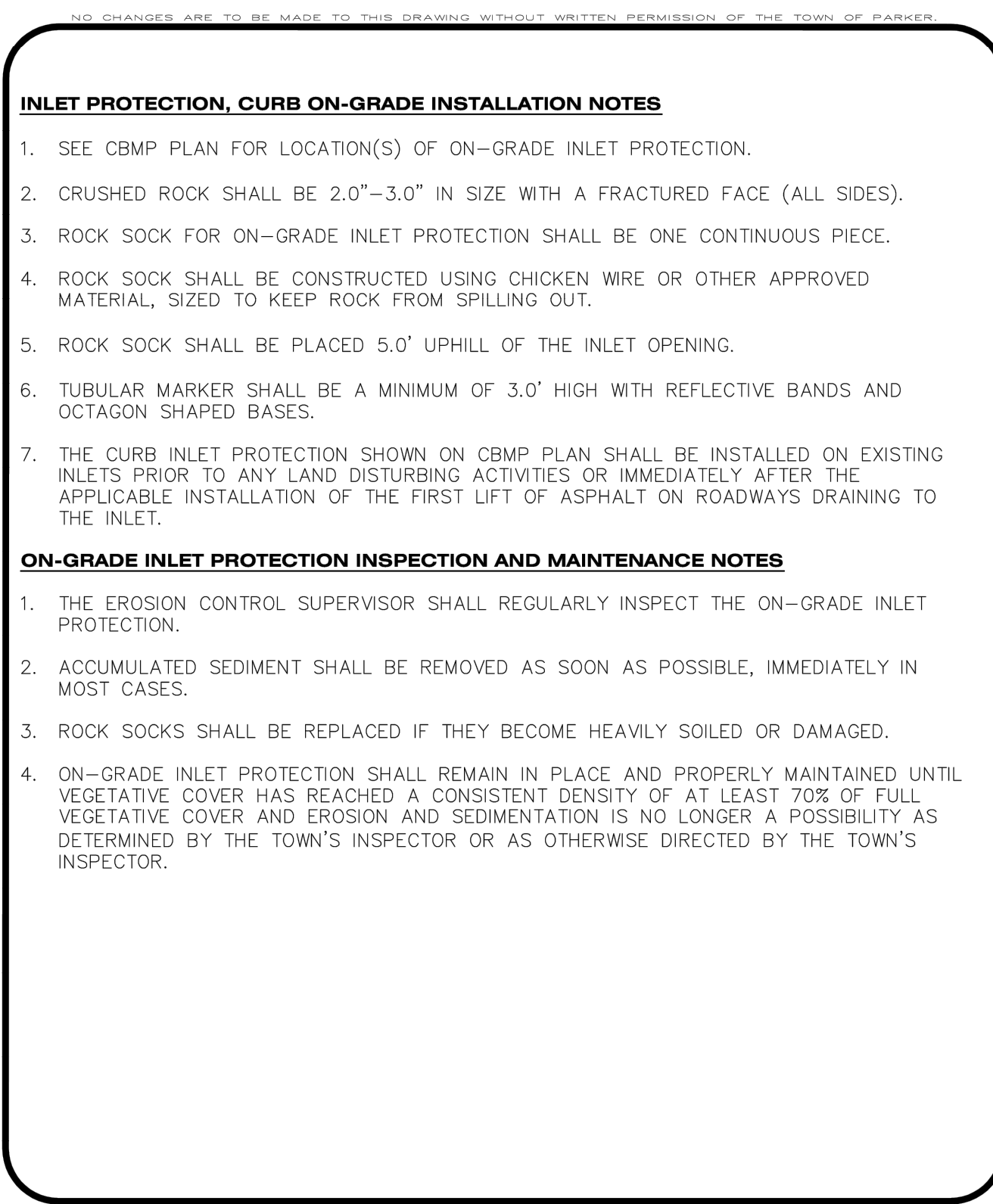

CBMP CONSTRUCTION BEST MANAGEMENT PRACTICES
IPC 3 OF 3
 Oct. 2013

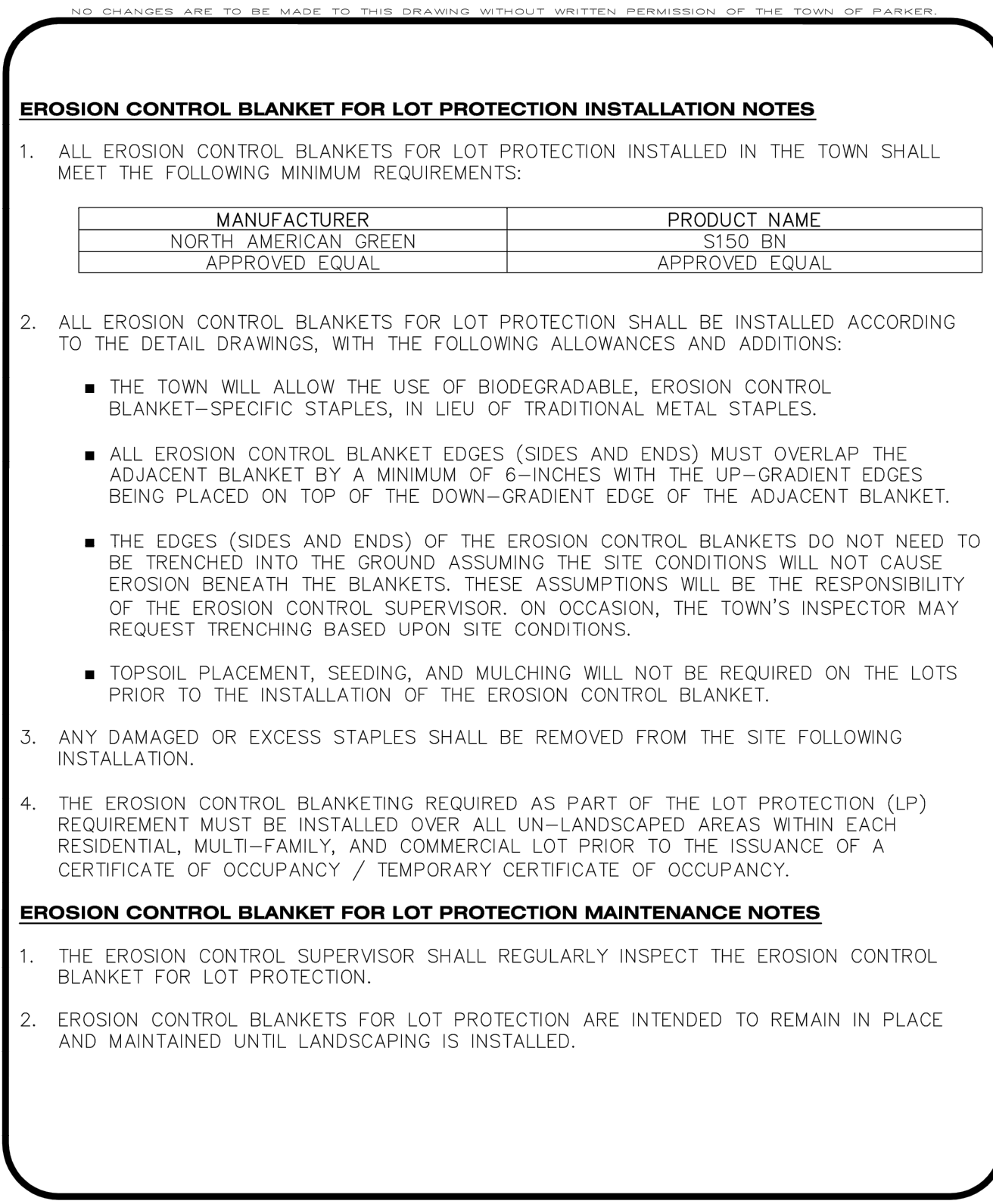

CBMP CONSTRUCTION BEST MANAGEMENT PRACTICES
LP 2 OF 2
 Oct. 2013

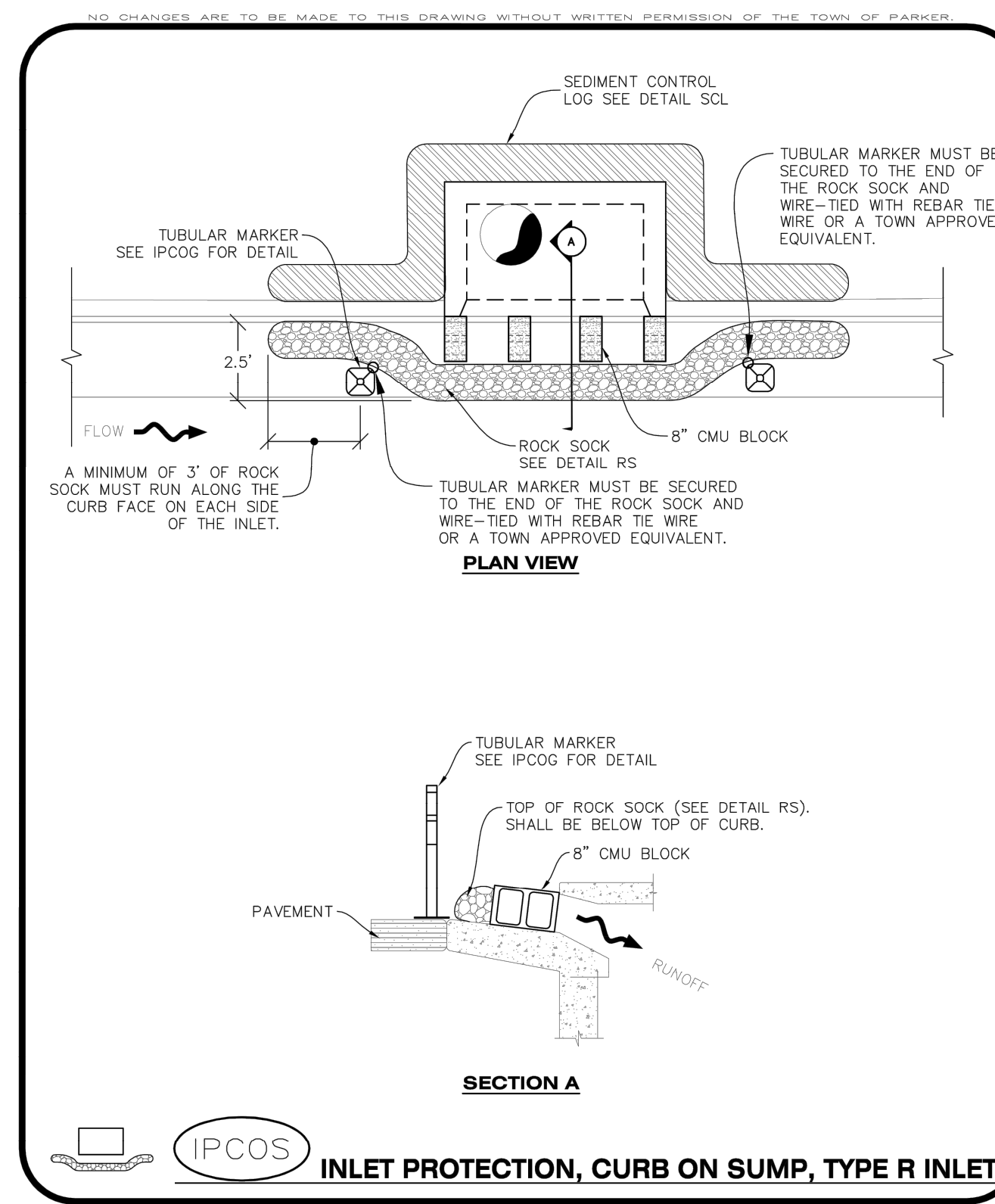

CBMP CONSTRUCTION BEST MANAGEMENT PRACTICES
IPC 1 OF 2
 Oct. 2013

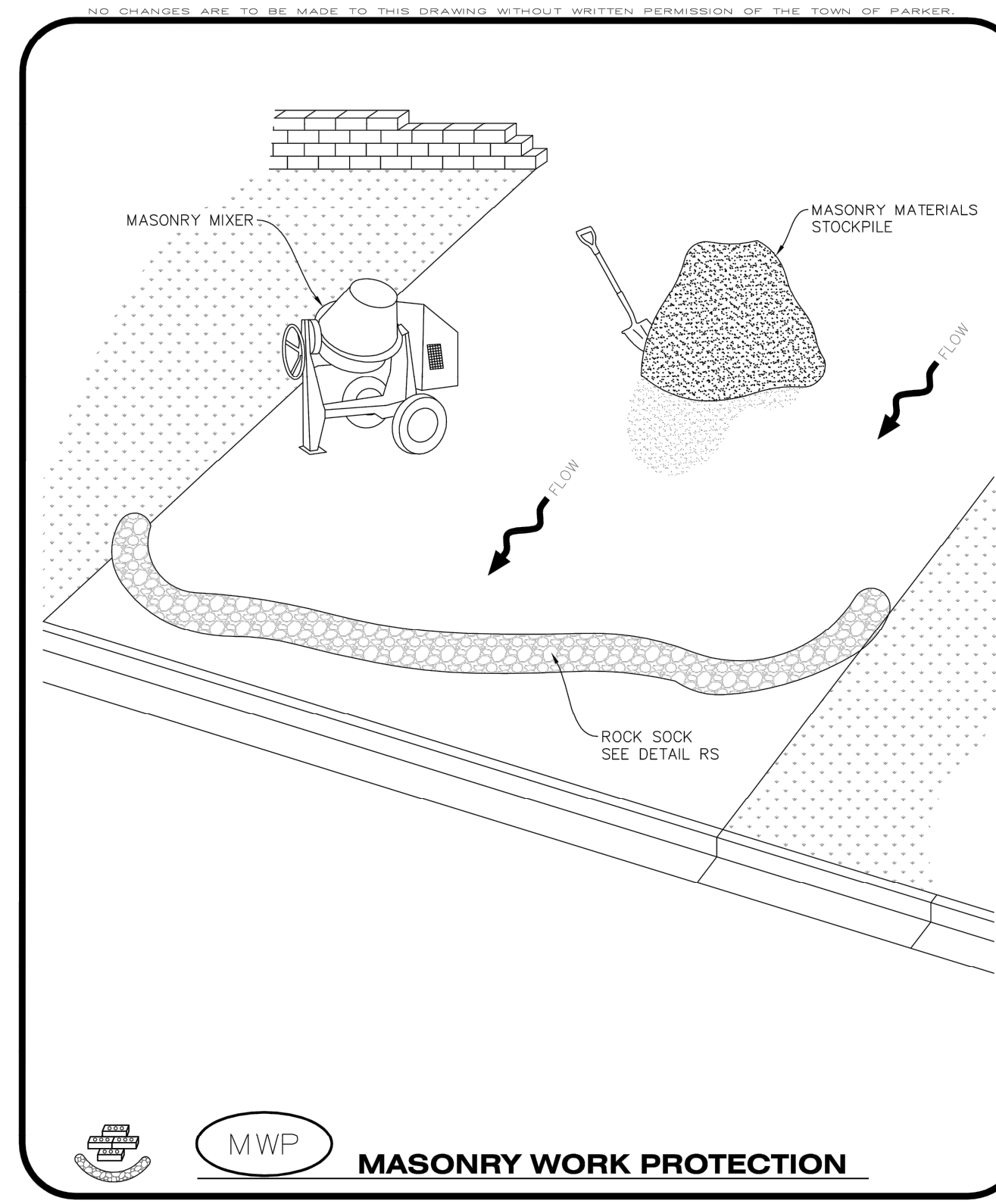

CBMP CONSTRUCTION BEST MANAGEMENT PRACTICES
MWP 1 OF 2
 Oct. 2013

NO.	REVISION	BY	DATE

Kimley»Horn
 2020 KIMLEY-HORN AND ASSOCIATES, INC.
 4582 South Ulster Street, Suite 1500
 Denver, Colorado 80237 (303) 228-2300

DESIGNED BY: DLS
 DRAWN BY: JRK
 CHECKED BY: DLS
 DATE: 04/19/21

PARKER AND PINE FILING NO. 2 LOTS 1-3
 PARKER, CO
 MULTI-FAMILY CONSTRUCTION DOCUMENTS
CBMP DETAILS

PRELIMINARY
 FOR REVIEW ONLY
 NOT FOR CONSTRUCTION
Kimley»Horn
 Kimley-Horn and Associates, Inc.

PROJECT NO.
 096481002
 DRAWING NAME
 096481002EC_DT
C3.6



