

\\horns-horn\csm\Net_data\DEL_Civil\096481002 - Parker & Pines ME\CADD\Drawings\096481002CV_LIT.dwg Sheet 01 of 10 10/18/2019 10:57 AM
 THIS DOCUMENT, INCLUDING ALL THE CONTENTS AND UNLESS OTHERWISE NOTED, IS THE PROPERTY OF KIMLEY-HORN AND ASSOCIATES, INC. IT IS TO BE USED ONLY FOR THE PROJECT AND SITE SPECIFICALLY IDENTIFIED HEREIN. NO PART OF THIS DOCUMENT IS TO BE REPRODUCED OR TRANSMITTED IN ANY FORM OR BY ANY MEANS, ELECTRONIC OR MECHANICAL, INCLUDING PHOTOCOPYING, RECORDING, OR BY ANY INFORMATION STORAGE AND RETRIEVAL SYSTEM.

PARKER WATER AND SANITATION GENERAL NOTES

- ALL MATERIALS AND WORKMANSHIP SHALL BE IN CONFORMANCE WITH THE PWSO ENGINEERING STANDARDS AND SPECIFICATIONS, LATEST VERSION.
- THE CONTRACTOR SHALL CONTACT ALL APPROPRIATE UTILITY COMPANIES AND THE TOWN OF PARKER, DOUGLAS COUNTY AND OTHER NEIGHBORING CITIES AND TOWNS PRIOR TO THE BEGINNING OF ANY CONSTRUCTION. CONTRACTOR SHALL BE RESPONSIBLE FOR LOCATING ANY EXISTING UTILITY (INCLUDING DEPTHS) WHICH MAY CONFLICT WITH THE PROPOSED CONSTRUCTION. ALL EXISTING UTILITIES SHALL BE PROTECTED FROM DAMAGE BY THE CONTRACTOR. DAMAGED UTILITIES SHALL BE REPAIRED BY THE CONTRACTOR AT HIS OWN EXPENSE.
- ALL ITEMS SHOWN ON THE PLANS AS EXISTING ARE SHOWN IN APPROXIMATE LOCATIONS ONLY. THE ACTUAL LOCATIONS MAY VARY FROM THE PLANS, ESPECIALLY IN THE CASE OF UNDERGROUND UTILITIES. WHENEVER THE CONTRACTOR DISCOVERS A DISCREPANCY IN LOCATIONS CONTACT THE PWSO IMMEDIATELY.
- PWSO ENGINEER AND OTHER APPROVING AGENCIES ARE TO BE NOTIFIED 48 HOURS PRIOR TO CONSTRUCTION.
- THE CONTRACTOR SHALL OBTAIN, AT HIS EXPENSE, ALL PERMITS NECESSARY TO PERFORM THE PROPOSED WORK.
- ALL CONCRETE SHALL BE A MINIMUM OF CLASS A, 6 SACK, TYPE II, 3000-POUND COMPRESSION STRENGTH.
- THE DESIGN ENGINEER SHALL SUBMIT ONE (1) SET OF "AS-BUILT" DRAWINGS AND ELECTRONIC FILES TO THE DISTRICT ENGINEER FOR APPROVAL BY DISTRICT. AFTER APPROVAL HAS BEEN GRANTED BY THE DISTRICT ENGINEER, FULL SIZE PRINTS SHALL BE TRANSMITTED TO THE PWSO OFFICE.
- NO WORK SHALL BE BACKFILLED UNTIL THE CONSTRUCTION HAS BEEN INSPECTED AND APPROVED FOR BACKFILLING BY THE DISTRICT ENGINEER OR REPRESENTATIVE OF THE DISTRICT ENGINEER. ALL BACKFILL MATERIAL SHALL BE COMPACTED TO 95% STANDARD PROCTOR DENSITY. COMPACTION TESTS MUST BE SUBMITTED TO DISTRICT ENGINEER PRIOR TO PROBATIONARY ACCEPTANCE.
- TRENCHES SHALL BE EXCAVATED AND THE PIPE EXPOSED FOR THE INSPECTION AT ANY LOCATION ON THE PROJECT IF SO ORDERED BY THE INSPECTOR.
- THE CONTRACTOR WILL BE HELD RESPONSIBLE FOR THE PROPER FUNCTIONING OF LINES (WATER AND DEPTHS) FOR UP TO TWO (2) YEARS FROM THE DATE OF PROBATIONARY ACCEPTANCE OF THE LINES BY THE DISTRICT. ANY MALFUNCTION DURING THIS PERIOD OF GUARANTEE SHALL BE REMEDIED BY THE CONTRACTOR TO THE SATISFACTION OF THE DISTRICT ENGINEER AT NO EXPENSE TO THE DISTRICT.
- SURFACE GRADES ARE TO BE WITHIN PLUS OR MINUS ONE FOOT OF FINISHED GRADE AND VERIFICATION OF COMPACTION RESULTS OBTAINED PRIOR TO THE INSTALLATION OF WATER AND SEWER LINES. RESULTS MUST BE SUBMITTED TO THE DISTRICT ENGINEER.
- ALL SERVICES WILL BE PERMANENTLY MARKED ON CURB FACE AS FOLLOWS:
 "X" FOR SANITARY SERVICE SEWERS
 "V" FOR WATER SERVICES
- NO TREES ALLOWED IN EASEMENTS OR WITHIN 8' OF WATER OR SANITARY SEWER MAINS IN RIGHT OF WAY.
- THE CONTRACTOR SHALL HAVE IN HIS POSSESSION AT ALL TIMES ONE (1) SIGNED COPY OF THE PLANS WHICH HAVE BEEN APPROVED BY THE PWSO AND THE DISTRICT ENGINEER AND ONE (1) COPY OF THE LATEST PWSO SPECIFICATION MANUAL.

ADDITIONAL NOTES

- ALL SANITARY SEWER AND STORM SEWER IMPROVEMENTS SHOWN HEREON SHALL BE PRIVATE. ALL WATER MAIN IMPROVEMENTS SHALL BE PUBLIC. REFER TO SPECIFIC PLAN SHEETS FOR MATERIALS AND ADDITIONAL DETAILS.
- TOWN OF PARKER REQUIRES 25' STORM SEWER EASEMENT.
- PARKER WATER AND SANITATION DISTRICT REQUIRES 30' EXCLUSIVE EASEMENT OR 50' NON-EXCLUSIVE EASEMENT.

SANITARY SEWER NOTES

- ALL MATERIALS AND WORKMANSHIP SHALL BE IN CONFORMANCE WITH THE PWSO ENGINEERING STANDARDS AND SPECIFICATIONS, LATEST VERSION.
- ALL SEWER MAINS SHALL BE PVC, ASTM D-3034, SDR 35 OR APPROVED EQUAL. ALL SEWER MAIN SIZE IS 8" IN DIAMETER UNLESS OTHERWISE NOTED.
- SEWER LINES SHALL BE INSTALLED 5.0 FEET SOUTH OR WEST OF STREET CENTERLINE, UNLESS OTHERWISE SHOWN ON PLANS. SEWER LINES SHALL BE 10.00 FEET FROM WATER LINES EXCEPT WHEN CROSSING EACH OTHER. SEWER LINES WHICH CROSS LESS THAN 1.50 FEET VERTICALLY FROM THE WATER MAIN SHALL BE ENCASED IN CONCRETE AS PER PWSO SPECIFICATIONS. USE RUBBER GASKETS FOR PVC ENCASEMENT.
- SEWER RIM ELEVATIONS SHOWN ARE APPROPRIATE ONLY AND ARE NOT TO BE TAKEN AS FINAL ELEVATIONS. RING AND COVER SHALL BE SET IN CENTERED CONCRETE RINGS WITH RAM-NECK FOR ADJUSTMENT TO MATCH FINAL PAVEMENT ELEVATIONS.
- THE CONTRACTOR AND SURVEY CREW SHALL VERIFY ELEVATIONS OF EXISTING SEWER LINES AND MANHOLES TO BE TIED TO PRIOR TO CONSTRUCTION OR STAKING OF SANITARY SEWER.
- NO UNDERDRAIN SYSTEM WILL BE ALLOWED TO BE PLACED IN MAINLINE OR SEWER SERVICE TRENCHES.
- SEWER SERVICE TEES FOR EACH UNIT SHALL BE STAKED BY A SURVEY CREW AND FURNISHED AND INSTALLED BY THE CONTRACTOR. THE CONTRACTOR SHALL FURNISH TO THE ENGINEER "AS CONSTRUCTED" LOCATION OF TEES. SEWER WYES SHALL BE USED RATHER THAN TEES.
- ALL MANHOLES SHALL BE 48-INCHES IN DIAMETER WITH 24-INCH RING AND COVER, ECCENTRIC CONE UNLESS OTHERWISE SPECIFIED. ALL MANHOLES SHALL HAVE SHAPED INVERTS.
- PIPE BEDDING SHALL BE CLASS "B" AND SHALL CONFORM TO ASTM C-33 OR D-448 GRADATION NO. 6 OR NO. 67.
- AT LEAST FIVE (5) DAYS PRIOR TO THE START OF CONSTRUCTION, A PRE-CONSTRUCTION MEETING WILL BE HELD AT THE OFFICE OF THE DISTRICT ENGINEER AND ATTENDED BY THE CONTRACTOR AND REPRESENTATIVES OF THE OTHER APPROVING AGENCIES. IT WILL BE THE RESPONSIBILITY OF THE CONTRACTOR TO CONTACT THE DISTRICT ENGINEER TO SCHEDULE THIS MEETING.
- THE CONTRACTOR SHALL HAVE IN HIS POSSESSION AT ALL TIMES ONE (1) SIGNED COPY OF THE PLANS WHICH HAVE BEEN APPROVED BY THE PWSO AND THE DISTRICT ENGINEER AND ONE (1) COPY OF THE LATEST PWSO SPECIFICATION MANUAL.
- ALL SEWER LINES SHALL BE TESTED IN ACCORDANCE WITH THE PWSO STANDARDS AND SPECIFICATIONS PRIOR TO ACCEPTANCE OR ANY CONNECTION TO AN EXISTING SEWER LINE.
- PRIOR TO STARTING WORK WHERE SEWER MAIN IS TO BE CONNECTED TO EXISTING PWSO SEWER SYSTEMS, THE NEAREST MANHOLE TO THE POINT OF TIE-IN SHALL BE PLUGGED WITH A PLUMBER'S PLUG ON THE INLET SIDE BY THE CONTRACTOR. THIS PLUG SHALL REMAIN IN PLACE UNTIL FINAL PROBATIONARY ACCEPTANCE BY PWSO. THE CONTRACTOR SHALL BE RESPONSIBLE FOR PUMPING AND CLEANING THESE MANHOLES AND REMOVING THE PLUG WHEN INSTRUCTED BY THE DISTRICT.
- PRIOR TO PROBATIONARY ACCEPTANCE WALK-THROUGH, THE CONTRACTOR SHALL JET CLEAN THE ENTIRE SANITARY SEWER SYSTEM AND PUMP OUT AT THE PLUGGED MANHOLE.

WATER MAIN NOTES

- ALL MATERIALS AND WORKMANSHIP SHALL BE IN CONFORMANCE WITH THE PWSO ENGINEERING STANDARDS AND SPECIFICATIONS, LATEST REVISION.
- ALL WATER MAINS SHALL BE PER PWSO MATERIALS SPECIFICATIONS. ALL MATERIALS IN CONTACT WITH POTABLE WATER SHALL BE SUITABLE FOR CHLORINATED AND CHLORAMINATED WATER.
- ALL BENDS, PLUGS, REDUCERS, AND FIRE HYDRANTS TO BE RODDED OR MEGA-LUGGED. ALL FITTINGS SHALL BE WRAPPED PER PWSO MATERIALS SPECIFICATIONS.
- THERE SHALL BE A MINIMUM COVER OF 4.5 FEET OVER ALL WATER MAINS.
- FIRE HYDRANTS SHALL CONFORM TO AWWA C-502 "DRY BARREL FIRE HYDRANTS" PIPE HYDRANT ASSEMBLIES PER PWSO SPECIFICATIONS.
- ALL BENDS, TEES, FIRE HYDRANTS, BLOW-OFFS, AND PLUGS AT DEAD-END MAINS SHALL BE PROTECTED FROM THRUST WITH CONCRETE THRUST BLOCKS.
- PRECAUTIONS SHALL BE TAKEN TO PROTECT THE INTERIOR OF PIPES, FITTINGS, AND VALVES AGAINST CONTAMINATION. ALL OPENINGS IN THE PIPELINE SHALL BE CLOSED WITH WATERTIGHT PLUGS WHEN PIPE LAYING IS STOPPED AT THE CLOSE OF THE DAY'S WORK OR FOR OTHER REASONS, SUCH AS REST BREAKS OR MEAL PERIODS.
- VALVES IN STREETS ARE TO BE LOCATED AT PROPERTY LINE EXTENSIONS EXCEPT FOR TAPPING TEES; WHERE AN ADDITIONAL VALVE SHALL BE PLACED ON THE TAPPING TEE. OTHER LOCATIONS SHOWN ON THE PLANS.
- WHEN NECESSARY TO LOWER OR RAISE WATER LINES AT STORM DRAINS AND OTHER UTILITY CROSSING, A MINIMUM CLEARANCE OF 1.5 FEET SHALL BE MAINTAINED BETWEEN OUTSIDE OF PIPES.
- THE CONTRACTOR SHALL NOTIFY THE PWSO AT LEAST 48 HOURS PRIOR TO ANY CONSTRUCTION. IF WORK IS SUSPENDED FOR ANY PERIOD OF TIME AFTER INITIAL START-UP, THE CONTRACTOR MUST NOTIFY THE DISTRICT ENGINEER 48 HOURS PRIOR TO RE-START.
- PIPE BEDDING SHALL BE A CLEAN, WELL-GRADED SAND OR SQUEEGEE SAND IN ACCORDANCE WITH PWSO STANDARDS AND SPECIFICATIONS, LATEST REVISION.
- THE CONTRACTOR SHALL NOTIFY THE PUBLIC UTILITY COMPANIES AND DETERMINE THE LOCATION OF ALL EXISTING UNDERGROUND UTILITIES PRIOR TO PROCEEDING WITH THE EXCAVATION. ALL WORK PERFORMED IN THE AREA OF THE PUBLIC UTILITIES SHALL BE PERFORMED ACCORDING TO THE REQUIREMENTS OF THESE AGENCIES.
- COMPACTION OF ALL TRENCHES MUST BE ATTAINED IN ACCORDANCE WITH THE SOILS REPORTS AND COMPACTION TEST RESULTS SUBMITTED TO THE DISTRICT ENGINEER PRIOR TO PROBATIONARY ACCEPTANCE.
- AT LEAST FIVE (5) DAYS PRIOR TO THE START OF CONSTRUCTION, A PRE-CONSTRUCTION MEETING WILL BE HELD AT THE OFFICE OF THE DISTRICT ENGINEER AND ATTENDED BY THE CONTRACTOR, DESIGN ENGINEER, AND REPRESENTATIVE OF OTHER APPROVING AGENCIES.
- CHLORINATION AND FLUSHING: ALL WATER MAINS SHALL BE INSTALLED AND CHLORINATED PER PWSO SPECIFICATIONS. CHLORINATION OF FINISHED PIPELINE COMPLETED BEFORE HYDROSTATIC TESTING.
- HYDROSTATIC TESTING: ALL WATER MAINS SHALL BE TESTED PER THE REQUIREMENTS OF THE PWSO SPECIFICATIONS UP TO MINIMUM OF 150 PSI IN THE PRESENCE OF A PWSO INSPECTOR/ENGINEER.

NO.	REVISION	BY	DATE



Kimley»Horn
 2020 KIMLEY-HORN AND ASSOCIATES, INC.
 4582 South Ulster Street, Suite 1500
 Denver, Colorado 80237 (303) 228-2300

DESIGNED BY: DLS
 DRAWN BY: JRK
 CHECKED BY: DLS
 DATE: 08/05/21

PARKER AND PINE FILING NO. 2 LOTS 1-3
 PARKER, CO
 MULTI-FAMILY CONSTRUCTION DOCUMENTS
WATER AND SANITARY SEWER NOTES



PROJECT NO.
 096481002

DRAWING NAME
 096481002CV_LIT

C7.1



\\parker-horn\scott\mt_4641\096481002 - Parker & Pines ME/CADD/Plan/Sheet/13.dwg Sheet 13 of 13 10/05/2010 10:57 AM
 THIS DOCUMENT, TOGETHER WITH THE CONCEPT AND DESIGN DESCRIBED HEREIN, IS INTENDED ONLY FOR THE PROJECT, LOCATION AND CLIENT FOR WHICH IT WAS PREPARED. NO OTHER USE OR REPRODUCTION OF THIS DOCUMENT WITHOUT WRITTEN AUTHORIZATION AND ADAPTATION BY KIMLEY-HORN AND ASSOCIATES, INC. SHALL BE WITHOUT LIABILITY TO KIMLEY-HORN AND ASSOCIATES, INC.

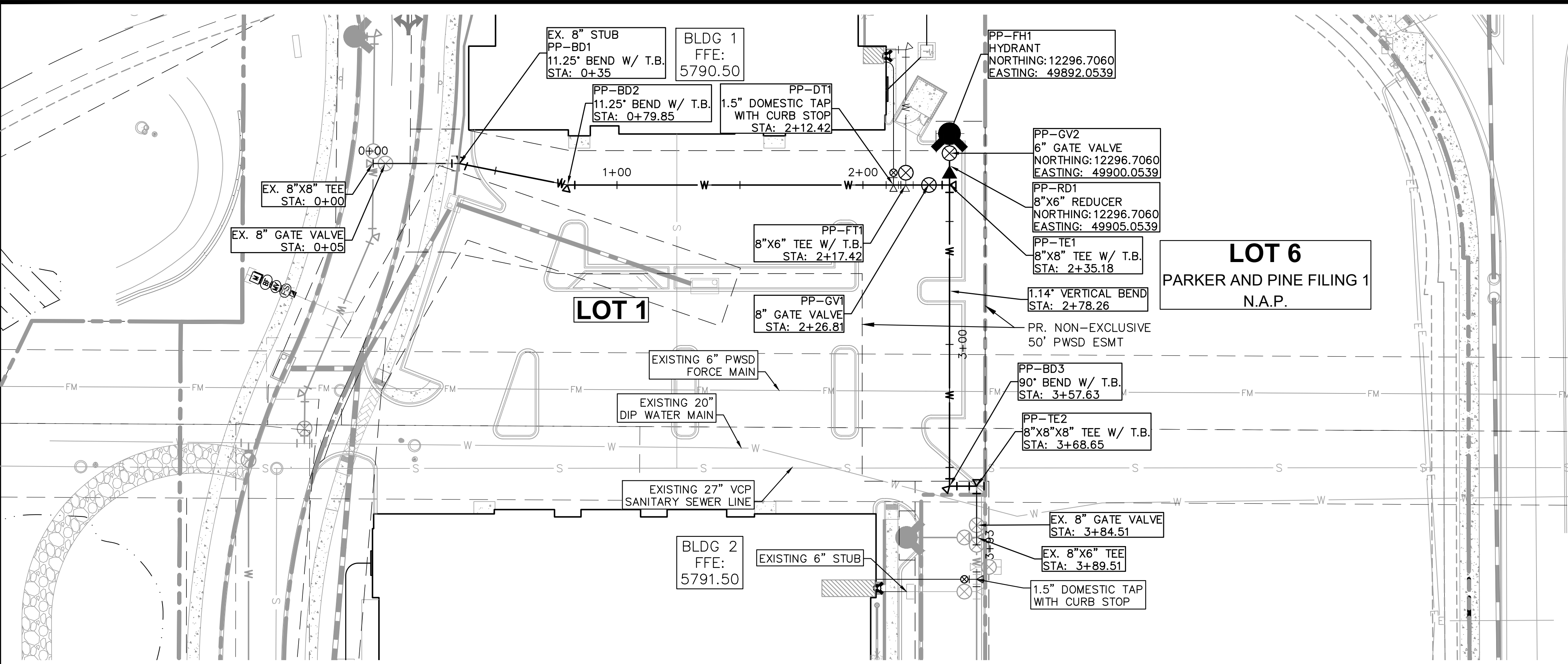

PINE LANE

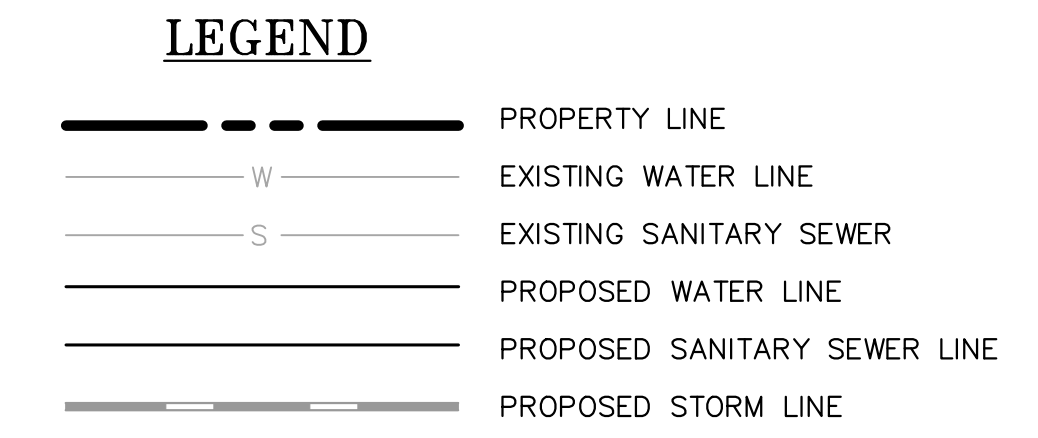

- WATER NOTES**
- CONTRACTOR TO POTHOLE EXISTING UTILITY LINES AT WATER LINE CROSSING AREAS PRIOR TO CONSTRUCTION.
 - WATER LINE CONNECTION ELEVATION TO EXISTING WATER MAINS IS APPROXIMATE. CONTRACTOR TO POTHOLE AND VERIFY TIE IN ELEVATION PRIOR TO CONSTRUCTION OF WATER MAIN.
 - CONTRACTOR TO MEET THE INSTALLATION REQUIREMENTS BY THE PARKER WATER AND SANITATION DISTRICT DESIGN STANDARDS AND CONSTRUCTION SPECIFICATIONS.
 - 24 UNIT BUILDINGS (BUILDINGS 1-7) SHALL PROVIDE INTERNAL BACKFLOW PREVENTER AND EXTERNAL 2" DOMESTIC METER.
 - 36 UNIT (BUILDING 8) SHALL PROVIDE INTERNAL BACK FLOW PREVENTERS AND 1-1/2" DOMESTIC METER.
 - VERTICAL BENDS AND DEFLECTIONS MAYBE UTILIZED TO PROVIDE VERTICAL CHANGES IN ACCORDANCE WITH PWSD STANDARDS AS NEEDED.
 - AT ALL POTABLE WATER MAIN AND SANITARY SEWER CROSSINGS WHERE THE PROPOSED SANITARY SEWER LINE LIES ABOVE THE PROPOSED WATER MAIN OR WITHIN 18" BELOW THE WATER MAIN, A CONCRETE ENCASEMENT IS TO BE PROVIDED ALONG THE SANITARY SEWER PIPE FOR 10 FT ON EITHER SIDE OF THE CROSSING. CONCRETE ENCASEMENT TO BE PROVIDED PER THE PWSD SECTION 9.3.2.
 - AT ALL STORM SEWER AND SANITARY SEWER CROSSINGS WHERE THE PROPOSED SANITARY SEWER LINE LIES ABOVE THE PROPOSED STORM SEWER OR WITHIN 18" BELOW THE STORM SEWER, A CONCRETE ENCASEMENT IS TO BE PROVIDED ALONG THE SANITARY SEWER PIPE FOR 10 FT ON EITHER SIDE OF THE CROSSING. CONCRETE ENCASEMENT TO BE PROVIDED PER THE PWSD SECTION 9.3.2.
 - ALL WATER LINES SHALL BE INSTALLED AT LEAST 4.5 FEET BELOW THE OFFICIAL STREET GRADE AND IN ALL OTHER PLACES AT LEAST 4.5 FEET BELOW THE SURFACE OF THE GROUND.
 - ALL FIRE HYDRANT AND UNDERGROUND FIRE LINES ARE TO BE DUCTILE IRON PIPE PER PWSD STANDARD SPECIFICATIONS AND DETAILS.

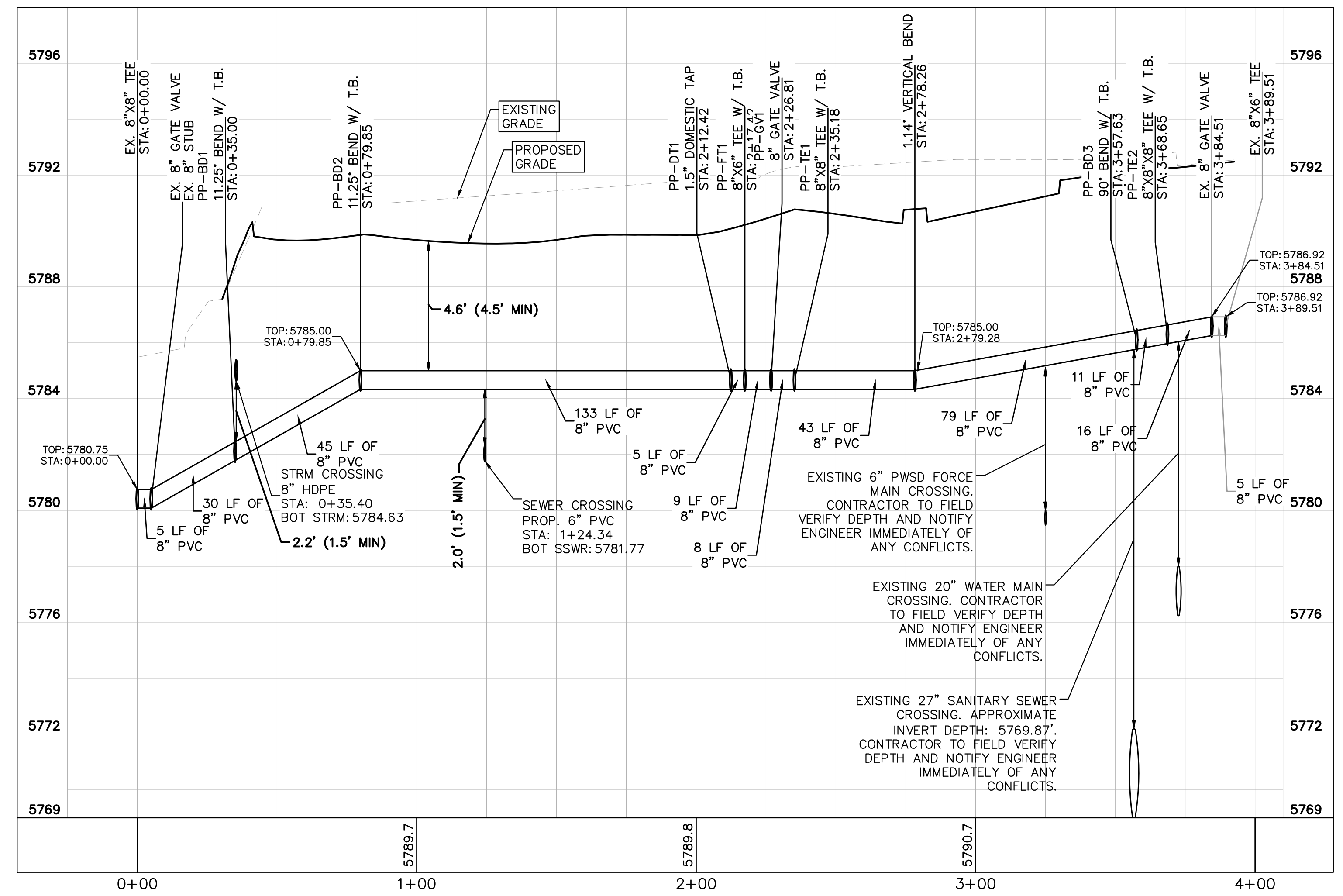

NO.	REVISION	BY	DATE						
2020 KIMLEY-HORN AND ASSOCIATES, INC. 4582 South Ulster Street, Suite 1500 Denver, Colorado 80237 (303) 228-2300									
DESIGNED BY: DLS DRAWN BY: JRK CHECKED BY: DLS DATE: 08/05/21									
PARKER AND PINE FILING NO. 2 LOTS 1-3 MULTI-FAMILY CONSTRUCTION DOCUMENTS WATER PLAN AND PROFILE									
PROJECT NO. 096481002									
DRAWING NAME 096481002CD_WT									
Know what's below. Call before you dig.									
C7.3									

\\kimley-horn\pcorn\dev\CD\096481002 - Parker & Pine\ME\CADD\Plan\Sheet\1-3\096481002CD_WT.dwg Sheet 1 of 1 Date: 10/05/2010 10:57 AM
 THIS DOCUMENT, INCLUDING ALL ATTACHED FILES, IS THE PROPERTY OF KIMLEY-HORN AND ASSOCIATES, INC. AND IS NOT TO BE REPRODUCED, COPIED, OR TRANSMITTED IN ANY FORM OR BY ANY MEANS, ELECTRONIC OR MECHANICAL, INCLUDING PHOTOCOPYING, RECORDING, OR BY ANY INFORMATION STORAGE AND RETRIEVAL SYSTEM, WITHOUT THE WRITTEN AUTHORIZATION AND ADAPTATION BY KIMLEY-HORN AND ASSOCIATES, INC. SHALL BE WITHOUT LIABILITY TO KIMLEY-HORN AND ASSOCIATES, INC.

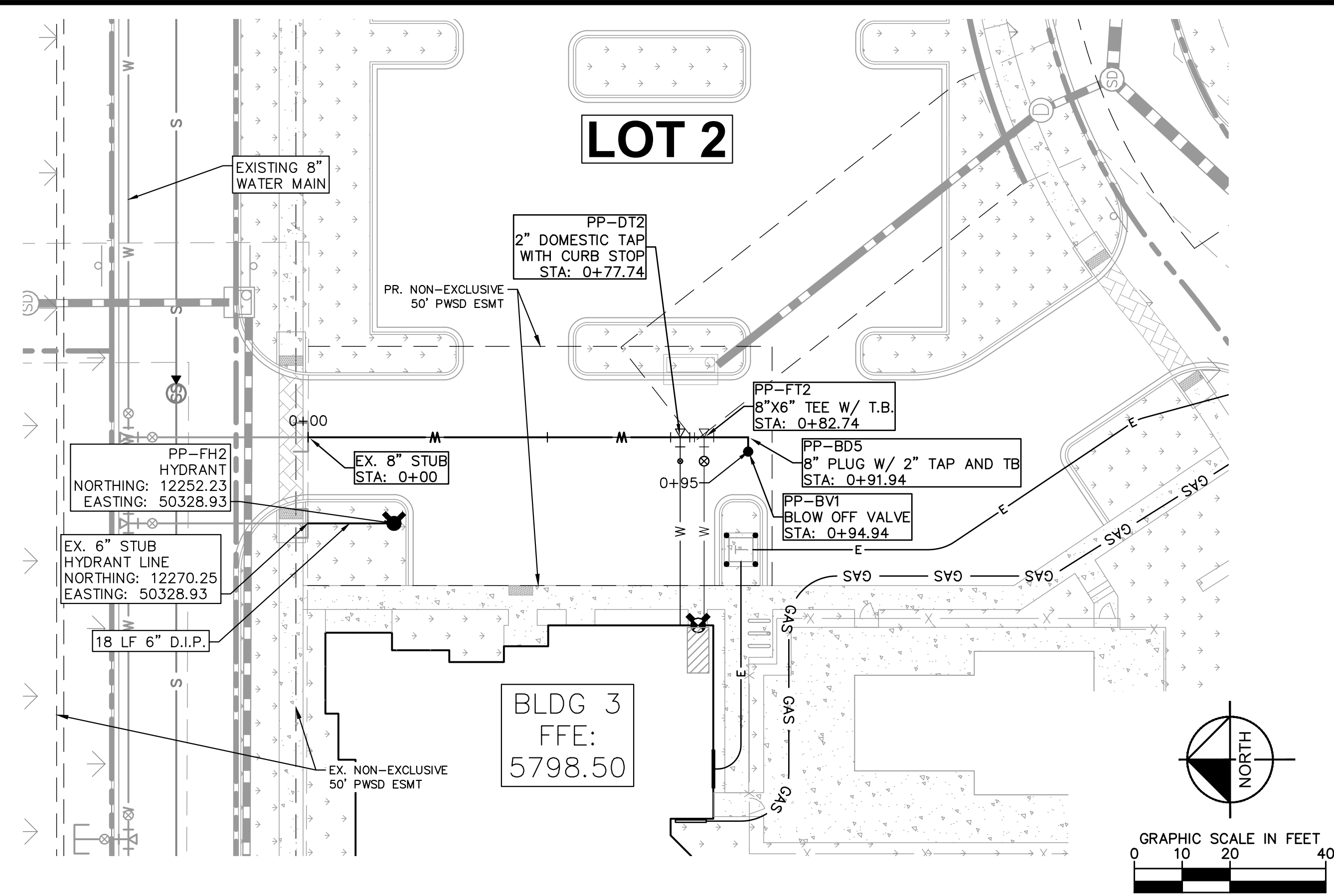

LEGEND

	PROPERTY LINE
	EXISTING WATER LINE
	EXISTING SANITARY SEWER
	PROPOSED WATER LINE
	PROPOSED SANITARY SEWER LINE
	PROPOSED STORM LINE

- WATER NOTES**
- CONTRACTOR TO POTHOLE EXISTING UTILITY LINES AT WATER LINE CROSSING AREAS PRIOR TO CONSTRUCTION.
 - WATER LINE CONNECTION ELEVATION TO EXISTING WATER MAINS IS APPROXIMATE. CONTRACTOR TO POTHOLE AND VERIFY TIE IN ELEVATION PRIOR TO CONSTRUCTION OF WATER MAIN.
 - CONTRACTOR TO MEET THE INSTALLATION REQUIREMENTS BY THE PARKER WATER AND SANITATION DISTRICT DESIGN STANDARDS AND CONSTRUCTION SPECIFICATIONS.
 - 24 UNIT BUILDINGS (BUILDINGS 1-7) SHALL PROVIDE INTERNAL BACKFLOW PREVENTER AND EXTERNAL 2" DOMESTIC METER.
 - 36 UNIT (BUILDING 8) SHALL PROVIDE INTERNAL BACK FLOW PREVENTERS AND 1-1/2" DOMESTIC METER.
 - VERTICAL BENDS AND DEFLECTIONS MAYBE UTILIZED TO PROVIDE VERTICAL CHANGES IN ACCORDANCE WITH PWSD STANDARDS AS NEEDED.
 - AT ALL POTABLE WATER MAIN AND SANITARY SEWER CROSSINGS WHERE THE PROPOSED SANITARY SEWER LINE LIES ABOVE THE PROPOSED WATER MAIN OR WITHIN 18" BELOW THE WATER MAIN, A CONCRETE ENCASEMENT IS TO BE PROVIDED ALONG THE SANITARY SEWER PIPE FOR 10 FT ON EITHER SIDE OF THE CROSSING. CONCRETE ENCASEMENT TO BE PROVIDED PER THE PWSD SECTION 9.3.2.
 - AT ALL STORM SEWER AND SANITARY SEWER CROSSINGS WHERE THE PROPOSED SANITARY SEWER LINE LIES ABOVE THE PROPOSED STORM SEWER OR WITHIN 18" BELOW THE STORM SEWER, A CONCRETE ENCASEMENT IS TO BE PROVIDED ALONG THE SANITARY SEWER PIPE FOR 10 FT ON EITHER SIDE OF THE CROSSING. CONCRETE ENCASEMENT TO BE PROVIDED PER THE PWSD SECTION 9.3.2.
 - ALL WATER LINES SHALL BE INSTALLED AT LEAST 4.5 FEET BELOW THE OFFICIAL STREET GRADE AND IN ALL OTHER PLACES AT LEAST 4.5 FEET BELOW THE SURFACE OF THE GROUND.
 - ALL FIRE HYDRANT AND UNDERGROUND FIRE LINES ARE TO BE DUCTILE IRON PIPE PER PWSD STANDARD SPECIFICATIONS AND DETAILS.

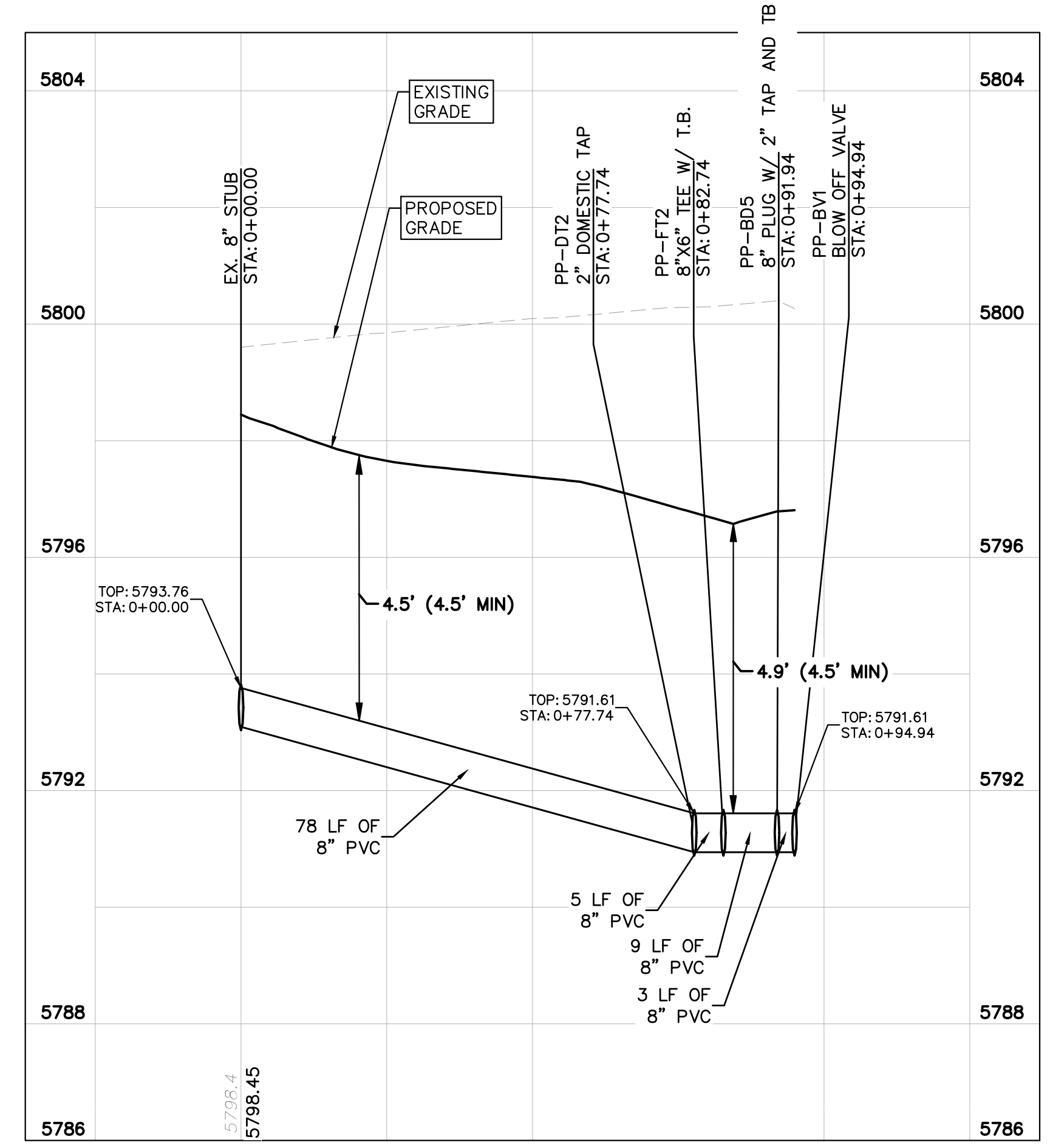

NO.	REVISION	BY	DATE	APPR

Kimley»Horn
 2020 KIMLEY-HORN AND ASSOCIATES, INC.
 4582 South Ulster Street, Suite 1500
 Denver, Colorado 80237 (303) 228-2300

DESIGNED BY: DLS
 DRAWN BY: JRK
 CHECKED BY: DLS
 DATE: 08/05/21

PARKER AND PINE FILING NO. 2 LOTS 1-3
 PARKER, CO
 MULTI-FAMILY CONSTRUCTION DOCUMENTS
WATER PLAN AND PROFILE

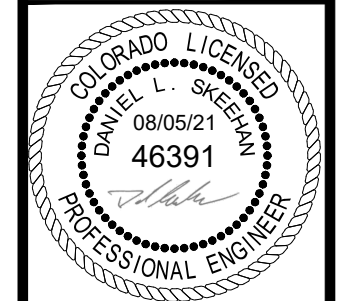

PROJECT NO.
 096481002

DRAWING NAME
 096481002CD_WT

C7.4



\\\minley-horn\pc\proj\096481002_01 - Parker & Pincus\DWG\DWG\096481002_UT.DWG Sheet 01 of 08 / 10/16/10 10:57 AM
 THIS DOCUMENT, INCLUDING ALL CONCEPTS AND DESIGNATIONS, IS THE PROPERTY OF KIMLEY-HORN AND ASSOCIATES, INC. IT IS TO BE USED ONLY FOR THE PROJECT AND SITE SPECIFICALLY IDENTIFIED HEREIN. NO PART OF THIS DOCUMENT IS TO BE REPRODUCED OR TRANSMITTED IN ANY FORM OR BY ANY MEANS, ELECTRONIC OR MECHANICAL, INCLUDING PHOTOCOPYING, RECORDING, OR BY ANY INFORMATION STORAGE AND RETRIEVAL SYSTEM, WITHOUT THE WRITTEN PERMISSION OF KIMLEY-HORN AND ASSOCIATES, INC.

- INSPECTION POLICY:**
- ALL SERVICE INSPECTIONS MUST BE SCHEDULED WITH THE DISTRICT OFFICE AT LEAST 24 HOURS IN ADVANCE OF THE REQUESTED INSPECTION.
 - IF THE CONTRACTOR IS NOT READY FOR INSPECTION WHEN THE INSPECTOR ARRIVES AT THE SITE, A RE-INSPECTION WILL HAVE TO BE SCHEDULED IN ACCORDANCE WITH NOTE 1 ABOVE AND A RE-INSPECTION FEE CHARGED.
 - SHOULD THE SERVICE LINES BE DAMAGED BY LATER CONSTRUCTION, AN INSPECTION OF THE REPAIR WILL BE REQUIRED IN ACCORDANCE WITH NOTES 1 AND 2 ABOVE.
 - THE CONTRACTOR SHALL LEAVE ALL PIPE AND FITTINGS EXPOSED FOR THE INSPECTOR TO OBSERVE. INSPECTORS WILL NOT ENTER ANY EXCAVATIONS TO CHECK MATERIALS. THE TOP LAYER OF BEDDING CAN BE ADDED AFTER THE INSPECTION HAS BEEN COMPLETED.
 - ALL EXCAVATIONS SHALL BE IN ACCORDANCE WITH OSHA STANDARDS.
 - LOTS WITHOUT BUILDING ADDRESSES OR LOT AND BLOCK NUMBERS BEFORE DISTRICT INSPECTION OR METER SET WILL FAIL AUTOMATICALLY.
 - CONTRACTOR MUST BE PRESENT AT TIME OF INSPECTION UNLESS COORDINATED WITH DISTRICT INSPECTOR.

- INSTALLATION NOTES:**
- SEWER:**
- ACCEPTABLE PIPE MATERIALS ARE TO BE SDR 35 PVC PIPE, ABS PIPE AND PVC SCHD 40 PIPE. APPROVED BEDDING IS TO BE SQUEEGEE.
 - NO-HUB CLAMPS SHALL BE USED TO JOIN 2 MALE PIPE ENDS WITH A MAXIMUM DEFLECTION OF 3".
 - MINIMUM GRADE SHALL BE 2%.
 - INSTALLATION SHALL INCLUDE NO MORE THAN 3 BENDS. 90° BENDS ARE NOT ALLOWED. SOLVENT WELDED PIPE WILL NOT BE ALLOWED.
 - CLEAN-OUTS SHALL BE INSTALLED AT 100' INTERVALS AND EVERY CHANGE IN DIRECTION. CLEAN-OUTS ARE NOT REQUIRED FOR SERVICES LESS THAN 100' UNLESS THERE ARE CHANGES IN DIRECTION. PROVIDE DUAL CLEAN-OUT WITHIN 5 FEET OF FOUNDATION.
 - STRESSING OF THE PIPE BETWEEN FITTINGS WILL NOT BE ALLOWED.
 - SEWER SERVICE LINE SHALL NOT BE LOCATED UNDER CONCRETE SURFACE.
 - ALL SERVICES WILL BE PERMANENTLY MARKED ON CURB FACE AS FOLLOWS:
 "X" FOR SANITARY SEWER SERVICE
 "V" FOR WATER SERVICES

PARKER WATER & SANITATION DISTRICT
DISTRICT POLICIES & INSTALLATION NOTES FOR SEWER SERVICES

SCALE: NONE	DATE: 2/96
APPROVED: PVR	01/02 10/16
DIRECTOR OF ENGINEERING	1/18

SHEET S1.1

2016 REVISION

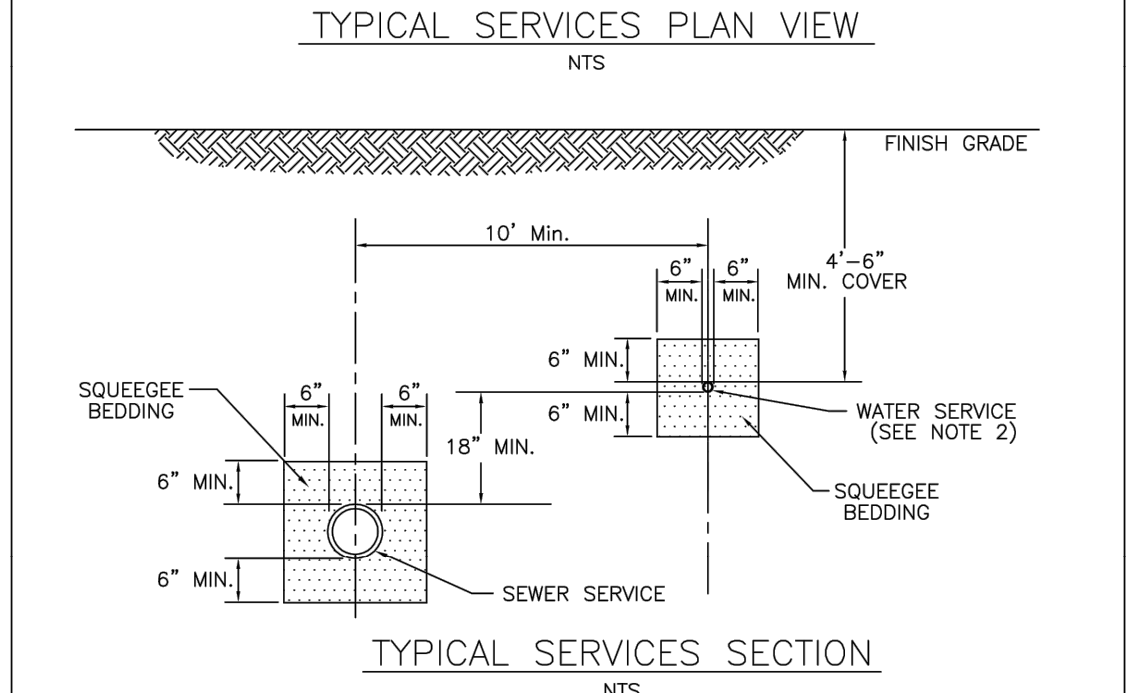
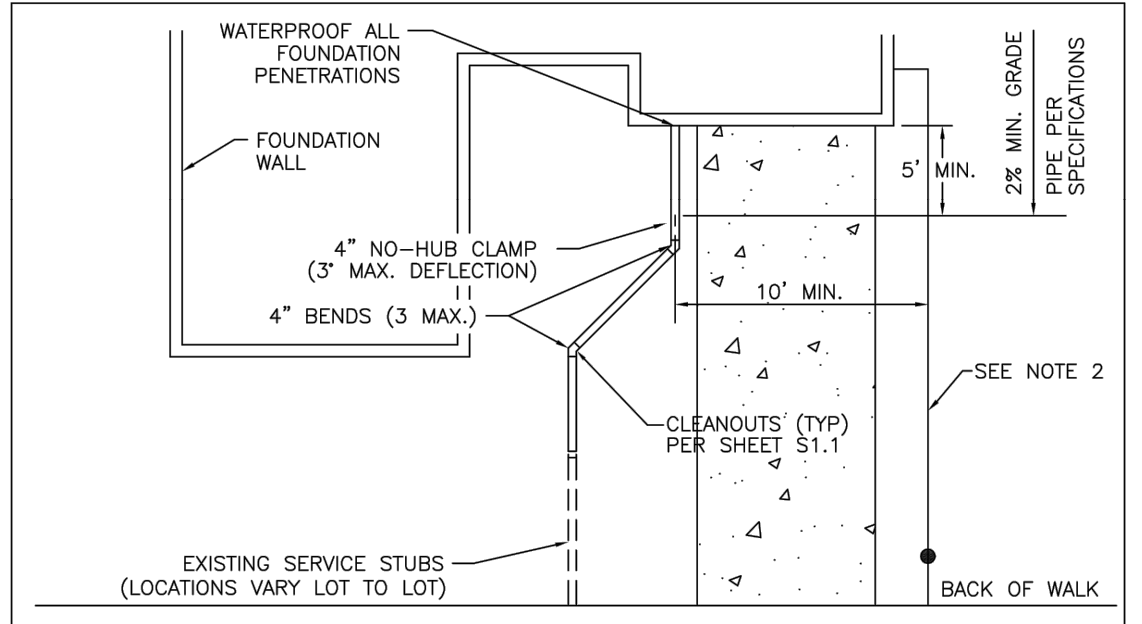

PARKER WATER & SANITATION DISTRICT
TYPICAL SEWER SERVICES

NOTE:

- SEE SHEET S1.1 FOR DISTRICT POLICIES AND INSTALLATION NOTES.
- TYPICAL WATER SERVICES SHOWN ON SHEET W1.2 IN WATER DETAILS.

SCALE: NONE	DATE: 2/96
APPROVED: PVR	01/02 10/16
DIRECTOR OF ENGINEERING	10/16

SHEET S1.2

2016 REVISION

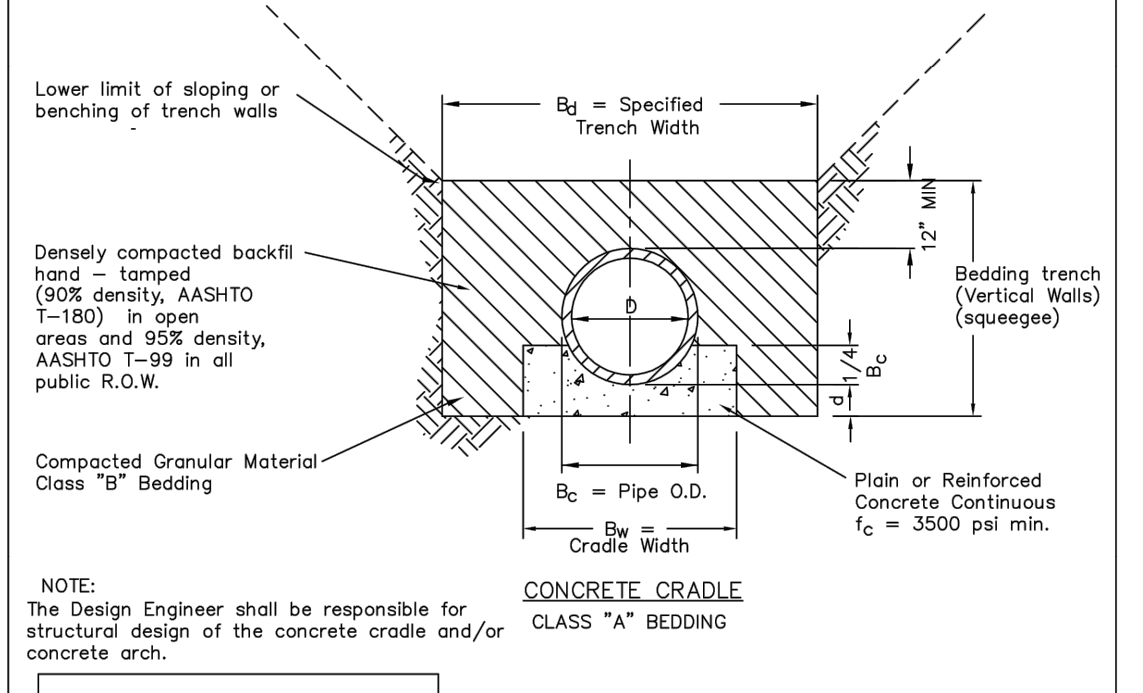
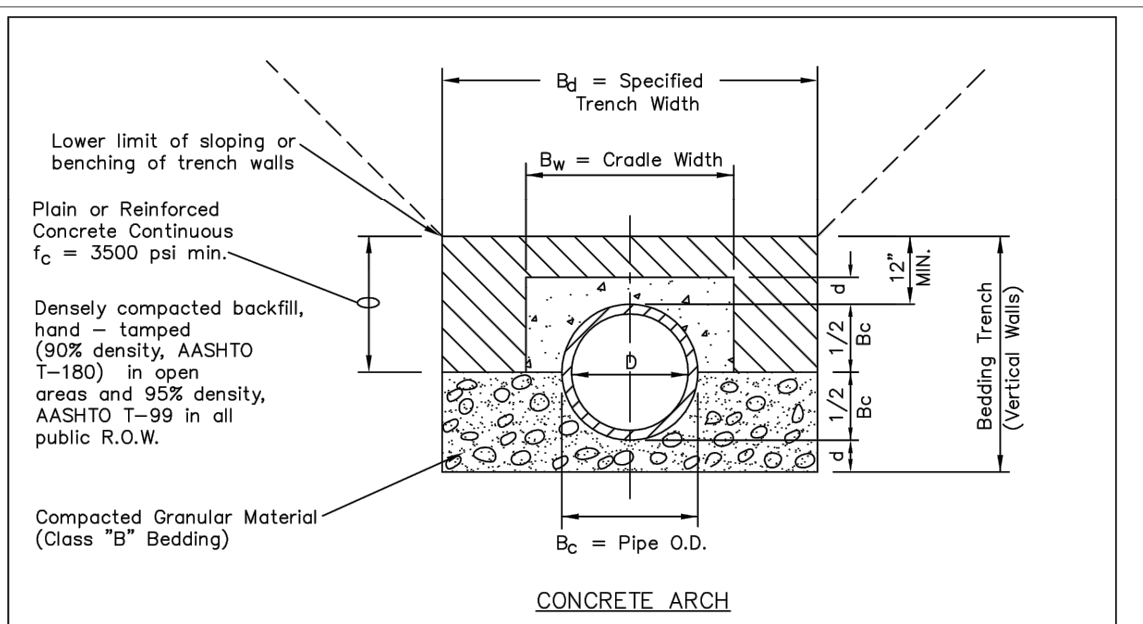

PARKER WATER & SANITATION DISTRICT
TRENCHING AND BEDDING DETAIL - CLASS "A"

NOMINAL DIAMETER (D)	MINIMUM THICKNESS (G)	MIN. WIDTH OF GRADE (B _w)
18" & smaller	6"	B _c + 8"
21" to 24"	6"	B _c + 8"
27" to 33"	8"	B _c + 8"
36" to 42"	10"	1.25 B _c
48" & larger	1/4 D	1.25 B _c

SCALE: NONE	DATE: 2/96
APPROVED: PVR	01/02 10/16
DIRECTOR OF ENGINEERING	10/16

SHEET S4.2

2016 REVISION

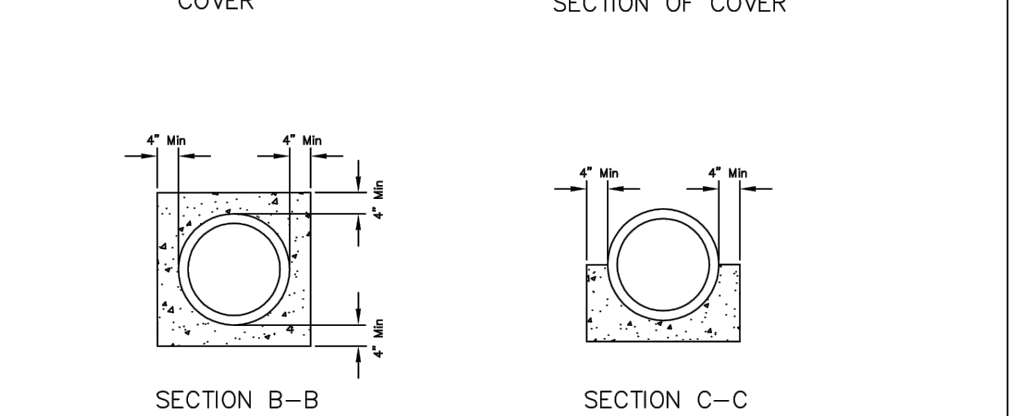
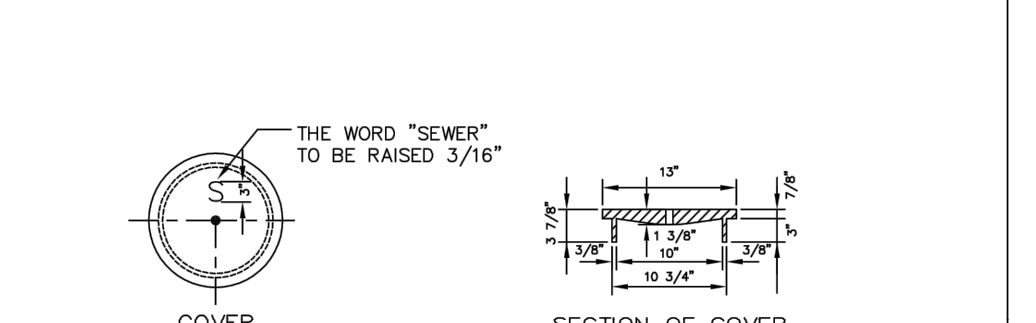
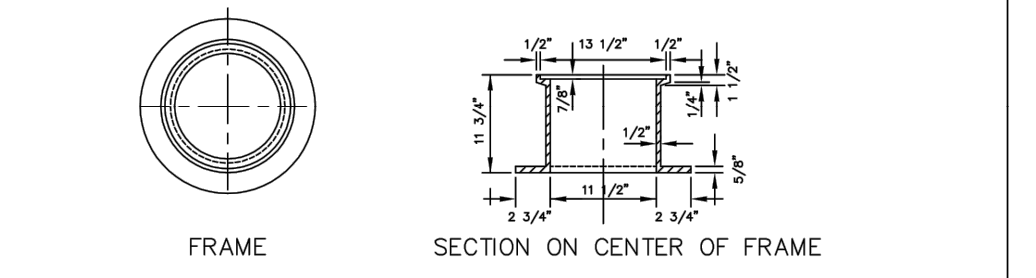

PARKER WATER & SANITATION DISTRICT
IN-LINE CLEANOUT SECTIONS

SCALE: NONE	DATE: 2/96
APPROVED: PVR	01/02 10/16
DIRECTOR OF ENGINEERING	10/16

SHEET S4.12

2016 REVISION

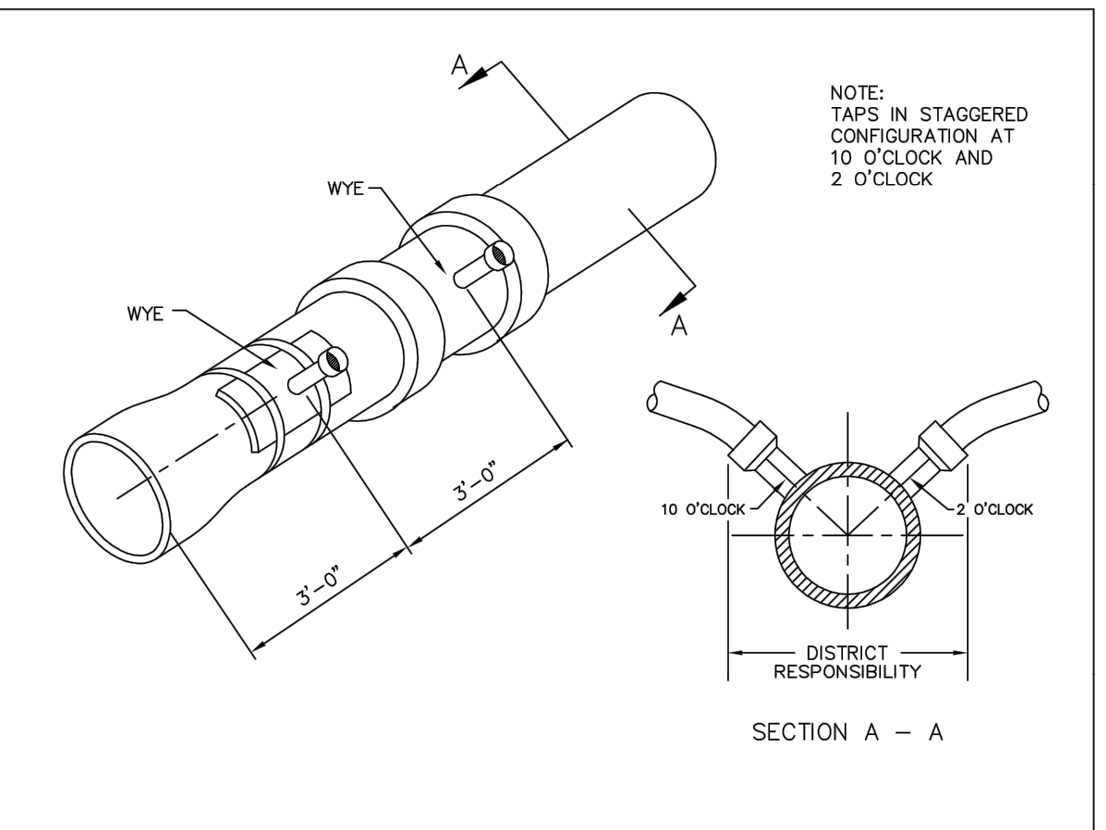

Sewer service connections shall be positioned at either the 2 o'clock or the 10 o'clock position on the circumference of the sewer main. On new installations, tee or wye fittings shall be used. When tapping into existing sewer main, a saddle connection and approved coring method shall be used. The minimum distance between service connections made along the pipe shall be 3 feet. The minimum distance from either the bell or spigot end of a pipe shall be 3 feet. The minimum distance from the center of a manhole to a service connection shall be either 7 feet or the transition point from the manhole trench to the normal pipe trench, whichever is greater. A maximum of 4 sewer service connections shall be allowed per 20 foot length of pipe. In all cases, a specific soils investigation should be conducted to assure that the external loading will be within allowable limits regardless of the number of taps involved.

PARKER WATER & SANITATION DISTRICT
DOMESTIC SEWER TAPPING DETAIL

SCALE: NONE	DATE: 2/96
APPROVED: PVR	4/01 1/08 1/16 10/16
DIRECTOR OF ENGINEERING	

SHEET S4.13

2016 REVISION

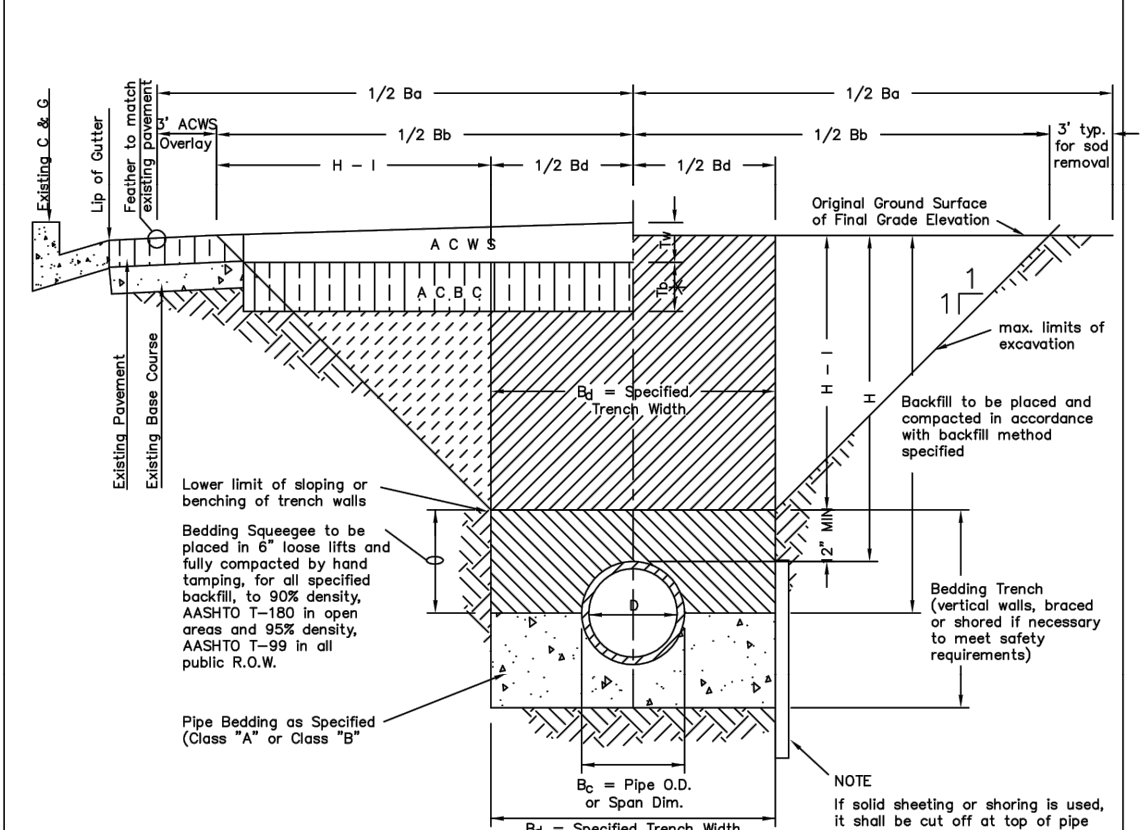

PARKER WATER & SANITATION DISTRICT
SEWER TRENCHING AND BEDDING DETAIL

STREET WIDTH	ASPHALT BASE COURSE (%)	ASPHALT WEARING SURFACE (%)	TOTAL THICKNESS (")
UP TO 36'	4"	2"	6"
36' TO 44'	4"	3"	7"
44' TO 48'	5"	3"	8"
WIDER THAN 48'	6"	3"	9"

SCALE: NONE	DATE: 2/96
APPROVED: PVR	5/98 1/18 10/16
DIRECTOR OF ENGINEERING	

SHEET S4.1

2016 REVISION

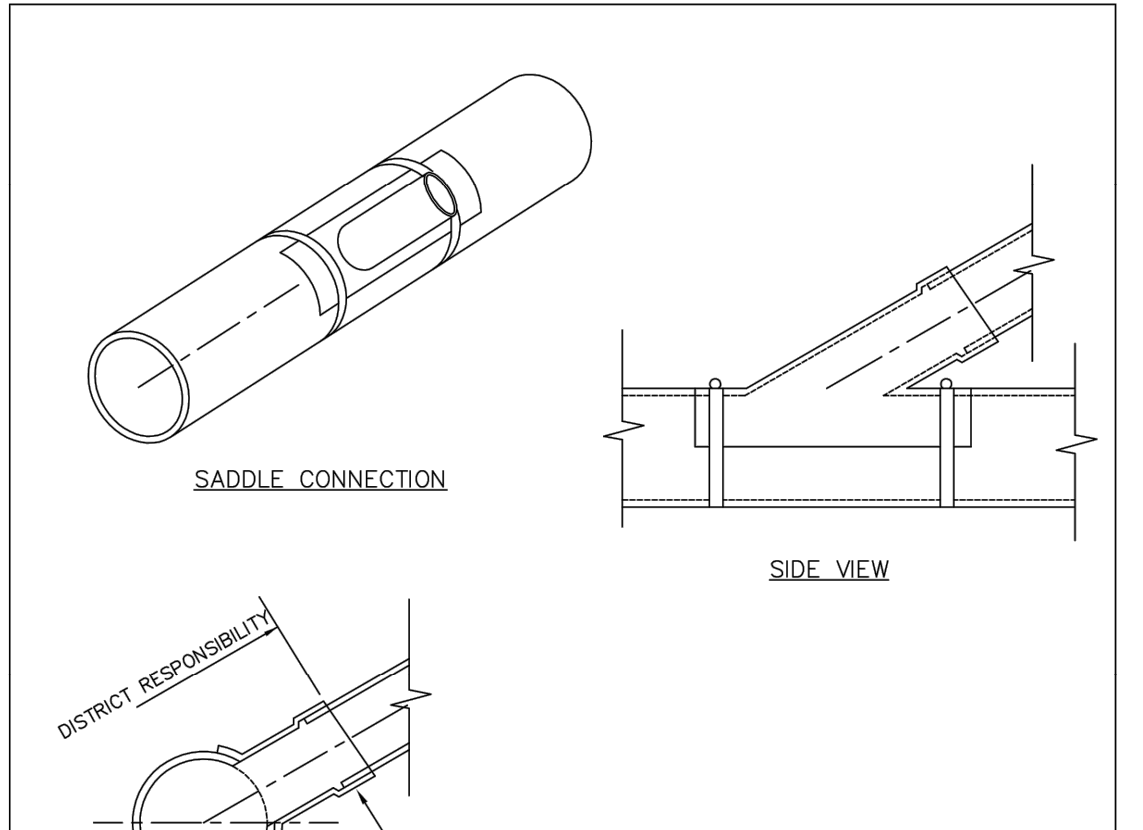

PARKER WATER & SANITATION DISTRICT
P.V.C. SADDLE CONNECTION DETAIL

SCALE: NONE	DATE: 2/96
APPROVED: PVR	1/16 10/16
DIRECTOR OF ENGINEERING	

SHEET S4.14

2016 REVISION

NO.	REVISION	BY	DATE	APPR

Kimley»Horn
2020 KIMLEY-HORN AND ASSOCIATES, INC.
4582 South Ulster Street, Suite 1500
Denver, Colorado 80237 (303) 228-2300

DESIGNED BY: DLS
DRAWN BY: JRK
CHECKED BY: DLS
DATE: 08/05/21

PARKER AND PINE FILING NO. 2 LOTS 1-3
PARKER, CO
MULTI-FAMILY CONSTRUCTION DOCUMENTS
UTILITY DETAILS



PROJECT NO.
096481002
DRAWING NAME
096481002UT_DT

C7.5

1. This document is the property of Kimley-Horn and Associates, Inc. and shall be returned to Kimley-Horn and Associates, Inc. upon completion of the project. 2. This document is not to be used for any other project without the written authorization of Kimley-Horn and Associates, Inc. 3. The information contained herein is for general informational purposes only and does not constitute an offer of engineering services. 4. The information contained herein is not to be used for any other project without the written authorization of Kimley-Horn and Associates, Inc. 5. The information contained herein is not to be used for any other project without the written authorization of Kimley-Horn and Associates, Inc. 6. The information contained herein is not to be used for any other project without the written authorization of Kimley-Horn and Associates, Inc. 7. The information contained herein is not to be used for any other project without the written authorization of Kimley-Horn and Associates, Inc. 8. The information contained herein is not to be used for any other project without the written authorization of Kimley-Horn and Associates, Inc. 9. The information contained herein is not to be used for any other project without the written authorization of Kimley-Horn and Associates, Inc. 10. The information contained herein is not to be used for any other project without the written authorization of Kimley-Horn and Associates, Inc.

CLAMP DETAILS

DIMENSIONS

PIPE DIA.	BAR SIZE	A	B	C	D	E	F	BOLT SIZES	PIPE DIA.
4	1-1/2	8-3/4	7-1/2	3-1/2	1-1/2	1	1	1/2	4
6	2-1/2	13	9-1/2	4	1-1/2	2	2	3/4	6
8	3-1/2	17-1/2	13-1/4	5-1/4	1-1/2	3	3	1	8
10	4-1/2	21-1/2	17-1/4	6-1/4	1-1/2	4	4	1-1/4	10
12	5-1/2	25-1/2	21-1/4	7-1/4	1-1/2	5	5	1-1/2	12
14	6-1/2	29-1/2	25-1/4	8-1/4	1-1/2	6	6	1-3/4	14
16	7-1/2	33-1/2	29-1/4	9-1/4	1-1/2	7	7	2	16
18	8-1/2	37-1/2	33-1/4	10-1/4	1-1/2	8	8	2-1/4	18
20	9-1/2	41-1/2	37-1/4	11-1/4	1-1/2	9	9	2-1/2	20
24	12	49-1/2	45-1/4	13-1/4	1-1/2	11	11	3	24

NOTE: ALL DIMENSIONS IN INCHES. CLAMPS MAY NOT BE USED ON PVC PIPE.

**PARKER WATER & SANITATION DISTRICT
CLAMP DETAILS AND DIMENSIONS**

SCALE: NONE DATE: 2/96
APPROVED: PVR 12/07
PVR 1/16
DIRECTOR OF ENGINEERING 10/16

2016 REVISION SHEET W3.15

STANDARD PIPE BEDDING

PIPE BEDDING IN ROCK

**PARKER WATER & SANITATION DISTRICT
BEDDING DETAILS**

SCALE: NONE DATE: 2/96
APPROVED: PVR 1/16
PVR 10/16
DIRECTOR OF ENGINEERING

2016 REVISION SHEET W4.8

ISOMETRIC VIEW

PLAN

**PARKER WATER & SANITATION DISTRICT
SERVICE LINE, STOP BOX & INSIDE METER SETTING (COMMERCIAL ONLY)**

SCALE: NONE DATE: 2/96
APPROVED: PVR 09/04/10/16
PVR 06/05/1/16
DIRECTOR OF ENGINEERING

2016 REVISION SHEET W5.9

**PARKER WATER & SANITATION DISTRICT
3\"/>

SCALE: NONE DATE: 2/96
APPROVED: PVR 1/16
PVR 10/16
DIRECTOR OF ENGINEERING

2016 REVISION SHEET W5.18**

PIPE SIZE	4"	6"	8"	12"	16"	20"	24"
TIE ROD	D	L	G	D	L	G	D
WASHER	D	L	G	D	L	G	D
ROD BEND	D	L	G	D	L	G	D
45° BEND	D	L	G	D	L	G	D
90° BEND	D	L	G	D	L	G	D
22-1/2° BEND	D	L	G	D	L	G	D
11-1/2° BEND	D	L	G	D	L	G	D

NOTE: 1. LENGTH OF TIE PIPE MEASURED EACH WAY FROM WATER AND BENDS. 2. CLAMPS AND RODS NOT ALLOWED FOR 24\"/>

**PARKER WATER & SANITATION DISTRICT
LENGTH OF TIED PIPE**

SCALE: NONE DATE: 2/96
APPROVED: PVR 4/01
PVR 1/16
DIRECTOR OF ENGINEERING 10/16

2016 REVISION SHEET W3.11

TIE RODS

A	B	C
3/4"	6"	1-10 1/8 & 20"
1-1/4"	ALL THREAD	1-10 1/8 & 20"

WASHERS

D	HOLE DIAMETER	F	G
3/4"	5/8"	6"	3/8"
1"	7/8"	6"	3/8"
1-1/4"	1-3/8"	7"	5/8"

**PARKER WATER & SANITATION DISTRICT
TIE ROD AND WASHER DETAILS**

SCALE: NONE DATE: 2/96
APPROVED: PVR 1/16
PVR 10/16
DIRECTOR OF ENGINEERING

2016 REVISION SHEET W3.12

TIE ROD COUPLING DETAIL

SECTION \"A-A\"

**PARKER WATER & SANITATION DISTRICT
TIE ROD COUPLING**

SCALE: NONE DATE: 2/96
APPROVED: PVR 1/16
PVR 10/16
DIRECTOR OF ENGINEERING

2016 REVISION SHEET W3.13

DIMENSIONS (IN INCHES)

PIPE DIA.	N	O	P	Q	R	S	U	V	PIPE DIA.
4	1-7/16	2	1	7/8	3/8	1	7/8	3/4	4
6	2-1/4	3-1/2	1	7/8	3/4	1	7/8	3/4	6
8	2-7/8	4-1/2	1	7/8	3/4	1	7/8	3/4	8
10	3-1/2	5-1/2	1	7/8	3/4	1-1/4	1-1/4	1-1/4	10
12	4-1/4	6-1/2	1	7/8	3/4	1-1/2	1-1/2	1-1/2	12
14	5-1/4	7-1/2	1	7/8	3/4	1-3/4	1-3/4	1-3/4	14
16	6-1/4	8-1/2	1	7/8	3/4	2	2	2	16
18	7-1/4	9-1/2	1	7/8	3/4	2-1/4	2-1/4	2-1/4	18
20	8-1/4	10-1/2	1	7/8	3/4	2-1/2	2-1/2	2-1/2	20

**PARKER WATER & SANITATION DISTRICT
FLANGE LUG DETAIL**

SCALE: NONE DATE: 2/96
APPROVED: PVR 1/16
PVR 10/16
DIRECTOR OF ENGINEERING

2016 REVISION SHEET W3.14

NO.	REVISION	BY	DATE	APPR.

Kimley»Horn

2020 KIMLEY-HORN AND ASSOCIATES, INC.
 4582 South Ulster Street, Suite 1500
 Denver, Colorado 80237 (303) 228-2300

DESIGNED BY: DLS
 DRAWN BY: JRK
 CHECKED BY: DLS
 DATE: 08/05/21

**PARKER AND PINE FILING NO. 2 LOTS 1-3
 PARKER, CO
 MULTI-FAMILY CONSTRUCTION DOCUMENTS
 UTILITY DETAILS**



PROJECT NO.
 096481002
 DRAWING NAME
 096481002UT_DT

C7.7

