

PARKER AND PINE FILING NO. 2 LOTS 1-3 PARKER WATER AND SANITATION DISTRICT

MULTI-FAMILY UTILITY PLANS

LOTS 1-3 AND TRACTS A-C, PARKER AND PINE FILING NO. 2
SITUATED IN THE SE 1/4 OF SECTION 9 AND THE SW 1/4 OF
SECTION 10, T.6S., R.66W. OF THE 6TH P.M.
TOWN OF PARKER, COUNTY OF DOUGLAS,
STATE OF COLORADO

CONTACTS:

DEVELOPER:
THE GARRETT COMPANIES
1051 GREENWOOD SPRINGS BLVD. SUITE 101
GREENWOOD, IN 46143
TEL: (317) 886-7926
CONTACT: KARL STOUT

ENGINEER:
KIMLEY-HORN AND ASSOCIATES, INC.
4582 SOUTH ULSTER STREET, SUITE 1500
DENVER, CO 80237
TEL: (303) 228-2318
CONTACT: DAN SKEEHAN

LANDSCAPE ARCHITECT:
THE GARRETT COMPANIES
1051 GREENWOOD SPRINGS BLVD. SUITE 101
GREENWOOD, IN 46143
TEL: (463) 444-7039
CONTACT: NICK SMITH

TELEPHONE:
CENTURYLINK
1801 CALIFORNIA STREET, SUITE 240
DENVER, CO 80202
CONTACT: IZZY MILLER
EMAIL: IZZY.MILLER@CENTURYLINK.COM

GAS SERVICE:
XCEL ENERGY
1800 LARIMER STREET
DENVER, CO 80202
CONTACT: RON JOHNSON
EMAIL: RON.H.JOHNSON@XCELENERGY.COM

ARCHITECT:
SEBREE ARCHITECTS, INC.
97 DOVER ST. SUITE 400
AVON, IN 46123
TEL: 317-272-7800 EXT. 224
CONTACT: DAWN LAYTON

SURVEYOR:
ENGINEERING SERVICE COMPANY
1300 SOUTH POTOMAC ST. SUITE 126
AURORA, CO 80012
TEL: 303-337-1393
CONTACT: JOHN PERRY, PLS

TELEVISION:
COMCAST
1601 MILE HIGH STADIUM CIRCLE
DENVER, CO 80204
CONTACT: DEAN FLENTHROPE
EMAIL: DEAN_FLENTHROPE@CABLE.COMCAST.COM

WATER/SANITARY SEWER:
PARKER WATER AND SANITATION DISTRICT
18100 E. WOODMAN ROAD
PARKER, CO 80134
TEL: 303-841-4627
CONTACT: DRAYTON SANDERSON

ELECTRICAL SERVICE:
IREA
5496 US HWY 85
SEDALIA, CO 80135
TEL: (303) 688-7431
CONTACT: AMANDA STEINER

TOWN OF PARKER:
TOWN OF PARKER
20120 EAST MAINSTREET
PARKER, CO 80138-7334
TEL: (303) 805-3199
CONTACT: STACEY NERGER

FIRE DEPARTMENT:
SOUTH METRO FIRE RESCUE AUTHORITY
9195 E. MINERAL AVE.
CENTENNIAL, CO 80112
TEL: (720) 989-2244
CONTACT: CHIP KERKHOVE

TOWN OF PARKER PLAN REVIEW:
PARKER WATER AND SANITATION DISTRICT
20120 E. MAINSTREET
PARKER, CO 80138
TEL: (303) 805-3174
CONTACT: BRYCE MATTHEWS



VICINITY MAP
1"=2,000'

Sheet List Table	
Sheet Number	Sheet Title
C7.0	COVER SHEET
C7.1	WATER AND SANITARY SEWER NOTES
C7.2	OVERALL UTILITY PLAN
C7.3	WATER PLAN AND PROFILE
C7.4	UTILITY DETAILS
C7.5	UTILITY DETAILS
C7.6	UTILITY DETAILS
C7.7	UTILITY DETAILS

SUMMARY OF QUANTITIES*

DESCRIPTION	QTY.	UNIT
6" PVC SANITARY SERVICE	418	LF
SANITARY SEWER CLEANOUT	6	EA
1.5" IRRIGATION SERVICE	10	LF
1.5" TYPE K COPPER SERVICE	52	LF
2" TYPE K COPPER SERVICE	119	LF
11.25" BEND	2	EA
22.5" BEND	2	EA
90° BEND	1	EA
8" GATE VALVE	1	EA
6" GATE VALVE	3	EA
8"x6" REDUCER	1	EA
8"x6" TEE	2	EA
8"x8" TEE	1	EA
FIRE HYDRANT	2	EA
BLOW OFF VALVE	1	EA
8" PVC WATER MAIN	438	LF
6" PVC FIRE LINE	183	LF
1.5" IRRIGATION METER	1	EA
1.5" INTERIOR DOMESTIC METER	1	EA
2" INTERIOR DOMESTIC METER	3	EA

*QUANTITIES ARE FOR REFERENCE ONLY.
CONTRACTOR SHALL VERIFY ALL QUANTITIES
PRIOR TO CONSTRUCTION

**4 SANITARY SEWER SERVICES, 4
DOMESTIC METERS, AND 1 IRRIGATION
SERVICE PROPOSED.

THE DISTRICT INSPECTOR MUST BE NOTIFIED AT LEAST 48 HOURS PRIOR TO START OF CONSTRUCTION. CALL PARKER WATER AND SANITATION DISTRICT AT 303-841-4627. THE DISTRICT WILL PROVIDE PERIODIC INSPECTIONS OF THE WORK. 24 HOUR NOTICE TO THE INSPECTOR IS REQUIRED FOR SCHEDULING INSPECTIONS.
ANY WORK ACCOMPLISHED WITHOUT THE APPROVAL OF THE INSPECTOR WILL BE SUBJECT TO REJECTION.

REVIEWED FOR CONFORMANCE TO PARKER WATER AND SANITATION DISTRICT STANDARDS.

BY: _____
(DISTRICT REPRESENTATIVE)

DATE: _____

APPROVED FOR CONSTRUCTION:
PARKER WATER AND SANITATION DISTRICT

BY: _____
(DISTRICT ENGINEER)

DATE: _____

FIRE CODE REVIEW BLOCK

ALL FIRE HYDRANTS SHALL BE INSTALLED ACCORDING TO WATER UTILITY STANDARDS. THE NUMBER AND LOCATIONS OF THE FIRE HYDRANTS AS SHOWN ON THE OVERALL UTILITY PLAN ARE CORRECT AS SPECIFIED BY THE TOWN OF PARKER, COMMUNITY DEVELOPMENT DEPARTMENT.

FIRE CODE OFFICIAL OR DESIGNATED REPRESENTATIVE _____ DATE _____

(NOTE - UNDERGROUND FIRE LINE (UFL) SUBMITTAL DOCUMENTS MUST MEET THE REQUIREMENTS OF NFPA 24 WHEN SUBMITTING FOR REVIEW.)

DISTRICT ACCEPTANCE NOTE

- UPON COMPLETION OF SANITARY AND WATER CONSTRUCTION AND TESTING, THE DEVELOPER OR CONTRACTOR SHALL CONTACT THE DISTRICT FOR PROBATIONARY ACCEPTANCE INSPECTION. A PUNCHLIST WILL BE PROVIDED FOR THE DEVELOPER AND CONTRACTOR UPON COMPLETION OF THE INITIAL WALK-THRU AND PROBATIONARY ACCEPTANCE WILL BE ISSUED FOLLOWING COMPLETION AND ACCEPTANCE OF THE WORK OUTLINED IN THE PUNCHLIST.
- THE CONTRACTOR WILL BE HELD RESPONSIBLE FOR THE PROPER FUNCTIONING OF THE LINES FOR UP TO TWO (2) YEARS FROM THE DATE OF PROBATIONARY ACCEPTANCE OF THE LINES BY THE DISTRICT. ANY MALFUNCTION DURING THIS PERIOD OF GUARANTEE SHALL BE REMEDIATED BY THE CONTRACTOR TO THE SATISFACTION OF THE DISTRICT ENGINEER AT NO EXPENSE TO THE DISTRICT.
- THE DATE OF FINAL ACCEPTANCE WILL BE INDICATED IN THE CONDITION OF THE PROBATIONARY ACCEPTANCE LETTER. THE DEVELOPER SHALL BE RESPONSIBLE FOR CONTACTING THE DISTRICT FOR FINAL INSPECTION AND FINAL ACCEPTANCE.

FLOODPLAIN NOTE

BY SCALED MAP LOCATION AND GRAPHIC PLOTTING ONLY, THIS PROPERTY LIES IN ZONE X OF THE FLOOD INSURANCE RATE MAP, COMMUNITY PANEL NUMBER 08035C0067G AND DATED MARCH 16, 2016 - SUBJECT PROPERTY IS NOT IN A SPECIAL FLOOD HAZARD AREA.

LEGAL DESCRIPTION

LOTS 1-3 AND TRACTS A-C, PARKER AND PINE FILING NO. 2, SITUATED IN THE SOUTHEAST 1/4 OF SECTION 9 AND THE SOUTHWEST 1/4 OF SECTION 10, TOWNSHIP 6 SOUTH, RANGE 66 WEST OF THE 6TH PRINCIPAL MERIDIAN, COUNTY OF DOUGLAS, STATE OF COLORADO.

BENCHMARK

DOUGLAS CONTROL MONUMENT #1.095035, A 3 1/4" ALUMINUM CAP.

ELEVATION = 5906.34 FEET (NAVD 1988), AS PUBLISHED BY DOUGLAS COUNTY.

BASIS OF BEARINGS

BEARINGS SHOWN HEREON ARE BASED UPON THE WEST LINE OF THE SW 1/4 OF SECTION 10, TOWNSHIP 6 SOUTH, RANGE 66 WEST OF THE 6TH PRINCIPAL MERIDIAN BEARING N00°17'51"E AS REFERENCED ON THE PLAT OF PARKER AUTO PLAZA FILING NO. 1 AND BOUND BY THE MONUMENTS SHOWN HEREON.

NO.	REVISION	BY	DATE

Kimley»Horn
2020 KIMLEY-HORN AND ASSOCIATES, INC.
4582 South Ulster Street, Suite 1500
Denver, Colorado 80237 (303) 228-2300

DESIGNED BY: DLS
DRAWN BY: JRK
CHECKED BY: DLS
DATE: 12/14/20

PARKER AND PINE FILING NO. 2 LOTS 1-3
PARKER, CO
MULTI-FAMILY CONSTRUCTION DOCUMENTS
COVER SHEET

PRELIMINARY
FOR REVIEW ONLY
NOT FOR
CONSTRUCTION
Kimley»Horn
Kimley-Horn and Associates, Inc.

PROJECT NO.
096481002

DRAWING NAME
096481002CV_UT

C7.0



\Users\horns\cm\N\dep\N\DEL_Civil\096481002 - Parker & Pine_MF\CAD\Drawings\Sheet\096481002CV_UT.dwg D:\p\7\10/16/2016 10:57 AM
 THIS DOCUMENT, INCLUDING ALL CONTENTS, IS THE PROPERTY OF KIMLEY-HORN AND ASSOCIATES, INC. IT IS TO BE USED ONLY FOR THE PROJECT AND LOCATION SPECIFICALLY IDENTIFIED HEREON. NO PART OF THIS DOCUMENT SHALL BE REPRODUCED OR TRANSMITTED IN ANY FORM OR BY ANY MEANS, ELECTRONIC OR MECHANICAL, INCLUDING PHOTOCOPYING, RECORDING, OR BY ANY INFORMATION STORAGE AND RETRIEVAL SYSTEM, WITHOUT THE WRITTEN PERMISSION OF KIMLEY-HORN AND ASSOCIATES, INC.

1. ALL SERVICE INSPECTIONS MUST BE SCHEDULED WITH THE DISTRICT OFFICE AT LEAST 24 HOURS IN ADVANCE OF THE REQUESTED INSPECTION.
 2. IF THE CONTRACTOR IS NOT READY FOR INSPECTION WHEN THE INSPECTOR ARRIVES AT THE SITE, A RE-INSPECTION WILL HAVE TO BE SCHEDULED IN ACCORDANCE WITH NOTE 1 ABOVE AND A RE-INSPECTION FEE CHARGED.
 3. SHOULD THE SERVICE LINES BE DAMAGED BY LATER CONSTRUCTION, AN INSPECTION OF THE REPAIR WILL BE REQUIRED IN ACCORDANCE WITH NOTES 1 AND 2 ABOVE.
 4. THE CONTRACTOR SHALL LEAVE ALL PIPE AND FITTINGS EXPOSED FOR THE INSPECTOR TO OBSERVE. INSPECTORS WILL NOT ENTER ANY EXCAVATIONS TO CHECK MATERIALS. THE TOP LAYER OF BEDDING CAN BE ADDED AFTER THE INSPECTION HAS BEEN COMPLETED.
 5. ALL EXCAVATIONS SHALL BE IN ACCORDANCE WITH OSHA STANDARDS.
 6. LOTS WITHOUT BUILDING ADDRESSES OR LOT AND BLOCK NUMBERS BEFORE DISTRICT INSPECTION OR METER SET WILL FAIL AUTOMATICALLY.
 7. CONTRACTOR MUST BE PRESENT AT TIME OF INSPECTION UNLESS COORDINATED WITH DISTRICT INSPECTOR.

INSPECTION POLICY:

- ALL SERVICE INSPECTIONS MUST BE SCHEDULED WITH THE DISTRICT OFFICE AT LEAST 24 HOURS IN ADVANCE OF THE REQUESTED INSPECTION.
- IF THE CONTRACTOR IS NOT READY FOR INSPECTION WHEN THE INSPECTOR ARRIVES AT THE SITE, A RE-INSPECTION WILL HAVE TO BE SCHEDULED IN ACCORDANCE WITH NOTE 1 ABOVE AND A RE-INSPECTION FEE CHARGED.
- SHOULD THE SERVICE LINES BE DAMAGED BY LATER CONSTRUCTION, AN INSPECTION OF THE REPAIR WILL BE REQUIRED IN ACCORDANCE WITH NOTES 1 AND 2 ABOVE.
- THE CONTRACTOR SHALL LEAVE ALL PIPE AND FITTINGS EXPOSED FOR THE INSPECTOR TO OBSERVE. INSPECTORS WILL NOT ENTER ANY EXCAVATIONS TO CHECK MATERIALS. THE TOP LAYER OF BEDDING CAN BE ADDED AFTER THE INSPECTION HAS BEEN COMPLETED.
- ALL EXCAVATIONS SHALL BE IN ACCORDANCE WITH OSHA STANDARDS.
- LOTS WITHOUT BUILDING ADDRESSES OR LOT AND BLOCK NUMBERS BEFORE DISTRICT INSPECTION OR METER SET WILL FAIL AUTOMATICALLY.
- CONTRACTOR MUST BE PRESENT AT TIME OF INSPECTION UNLESS COORDINATED WITH DISTRICT INSPECTOR.

INSTALLATION NOTES:

SEWER:

- ACCEPTABLE PIPE MATERIALS ARE TO BE SDR 35 PVC PIPE, ABS PIPE AND PVC SCHD 40 PIPE. APPROVED BEDDING IS TO BE SQUEEGEE.
- NO-HUB CLAMPS SHALL BE USED TO JOIN 2 MALE PIPE ENDS WITH A MAXIMUM DEFLECTION OF 3'.
- MINIMUM GRADE SHALL BE 2X.
- INSTALLATION SHALL INCLUDE NO MORE THAN 3 BENDS. 90° BENDS ARE NOT ALLOWED. SOLVENT WELDED PIPE WILL NOT BE ALLOWED.
- CLEAN-OUTS SHALL BE INSTALLED AT 100' INTERVALS AND EVERY CHANGE IN DIRECTION. CLEAN-OUTS ARE NOT REQUIRED FOR SERVICES LESS THAN 100' UNLESS THERE ARE CHANGES IN DIRECTION. PROVIDE DUAL CLEAN-OUT WITHIN 5 FEET OF FOUNDATION.
- STRESSING OF THE PIPE BETWEEN FITTINGS WILL NOT BE ALLOWED.
- SEWER SERVICE LINE SHALL NOT BE LOCATED UNDER CONCRETE SURFACE.
- ALL SERVICES WILL BE PERMANENTLY MARKED ON CURB FACE AS FOLLOWS:
 "X" FOR SANITARY SEWER SERVICE
 "V" FOR WATER SERVICES

PARKER WATER & SANITATION DISTRICT
DISTRICT POLICIES & INSTALLATION NOTES FOR SEWER SERVICES

SCALE: NONE	DATE: 2/96
APPROVED: PVR	6/02 10/16
	1/08 1/16
DIRECTOR OF ENGINEERING	

SHEET S1.1

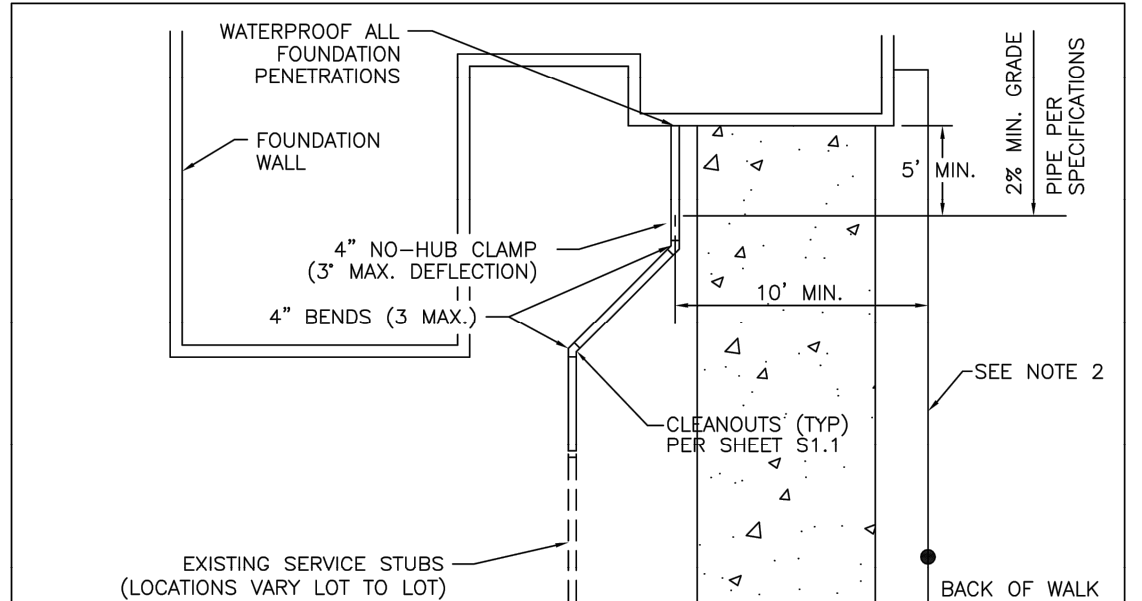

TYPICAL SERVICES PLAN VIEW
NTS

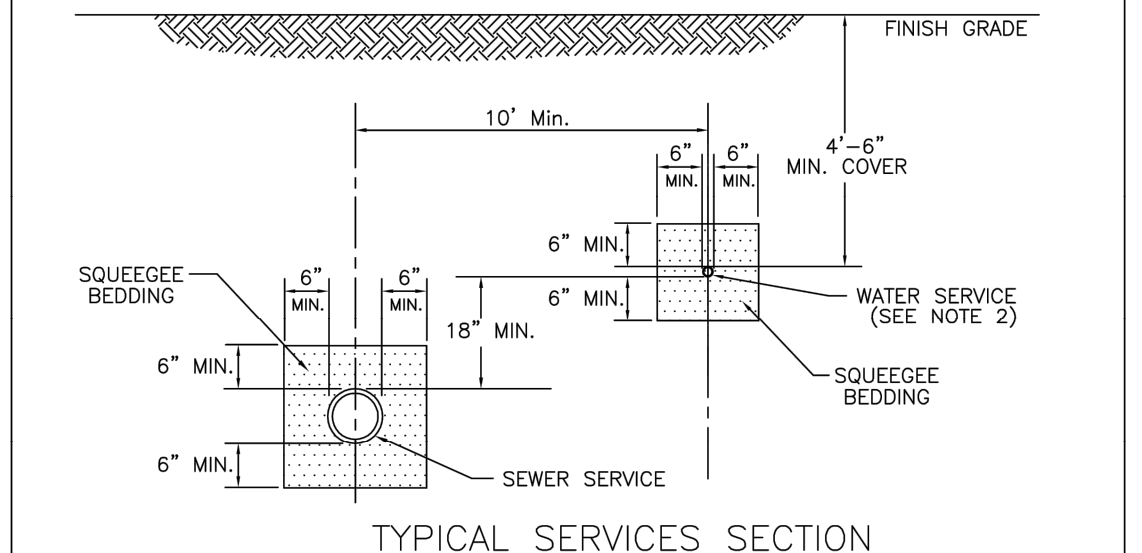

TYPICAL SERVICES SECTION
NTS

PARKER WATER & SANITATION DISTRICT
TYPICAL SEWER SERVICES

NOTE:
1. SEE SHEET S1.1 FOR DISTRICT POLICIES AND INSTALLATION NOTES.
2. TYPICAL WATER SERVICES SHOWN ON SHEET W1.2 IN WATER DETAILS.

SCALE: NONE	DATE: 2/96
APPROVED: PVR	2/00 01/02 01/16
DIRECTOR OF ENGINEERING	10/16

SHEET S1.2

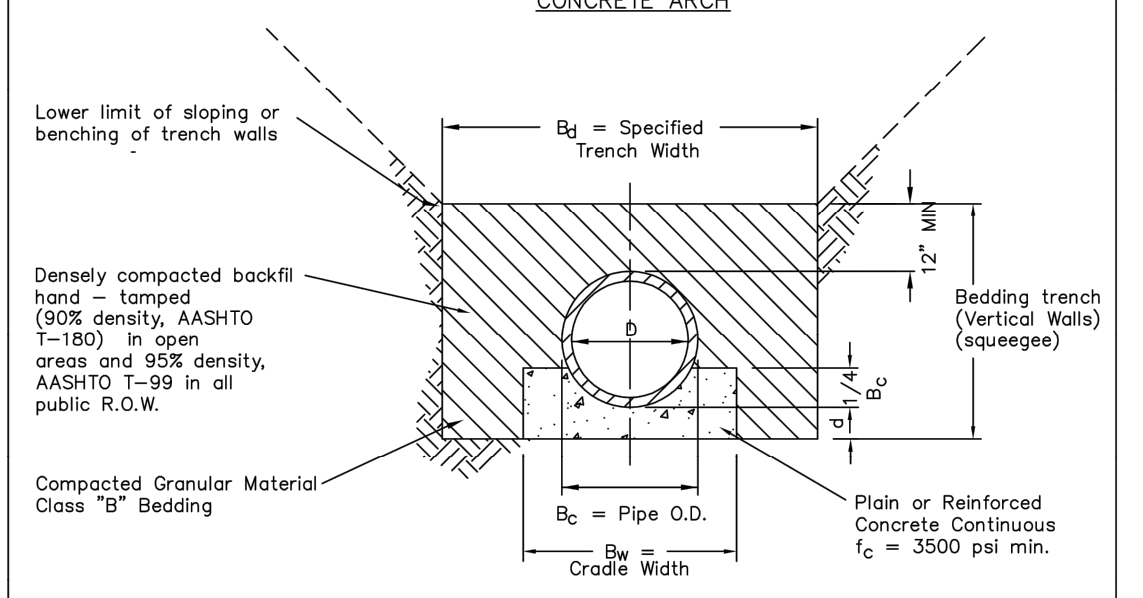
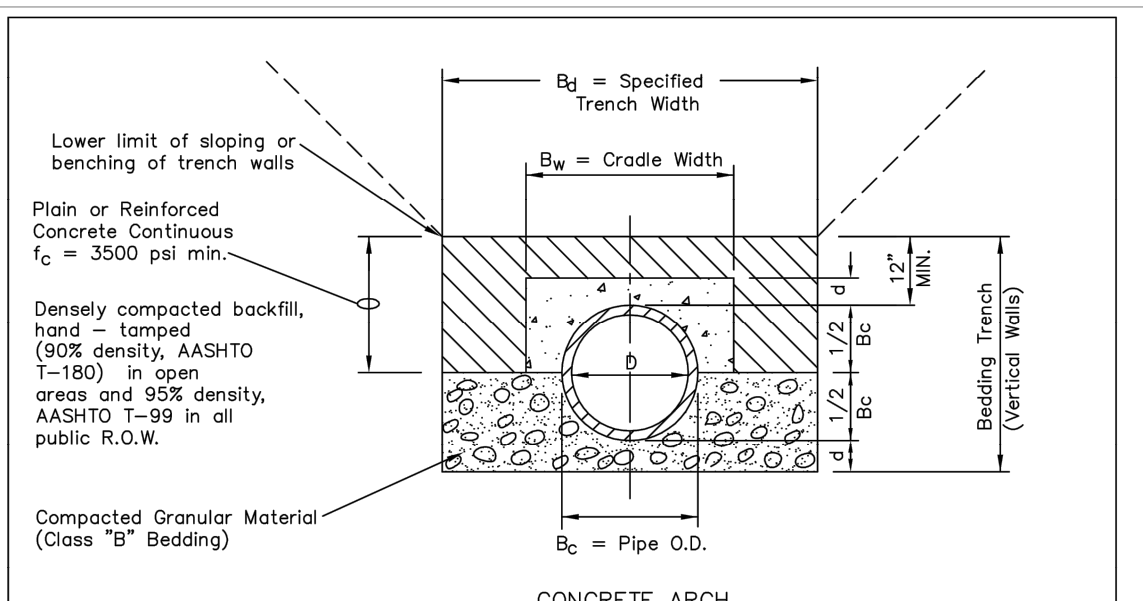

NOTE:
The Design Engineer shall be responsible for structural design of the concrete cradle and/or concrete arch.

PARKER WATER & SANITATION DISTRICT
TRENCHING AND BEDDING DETAIL - CLASS "A" BEDDING

NOMINAL DIAMETER (D)	MINIMUM THICKNESS (G)	MIN. WIDTH OF GRADE (Bw)
18" & smaller	6"	8" Bc = 8"
21" to 24"	6"	8" Bc = 8"
27" to 33"	8"	8" Bc = 8"
36" to 42"	10"	1.25 Bc
48" & larger	1/A D	1.25 Bc

SCALE: NONE	DATE: 2/96
APPROVED: PVR	1/16 10/16
DIRECTOR OF ENGINEERING	

SHEET S4.2

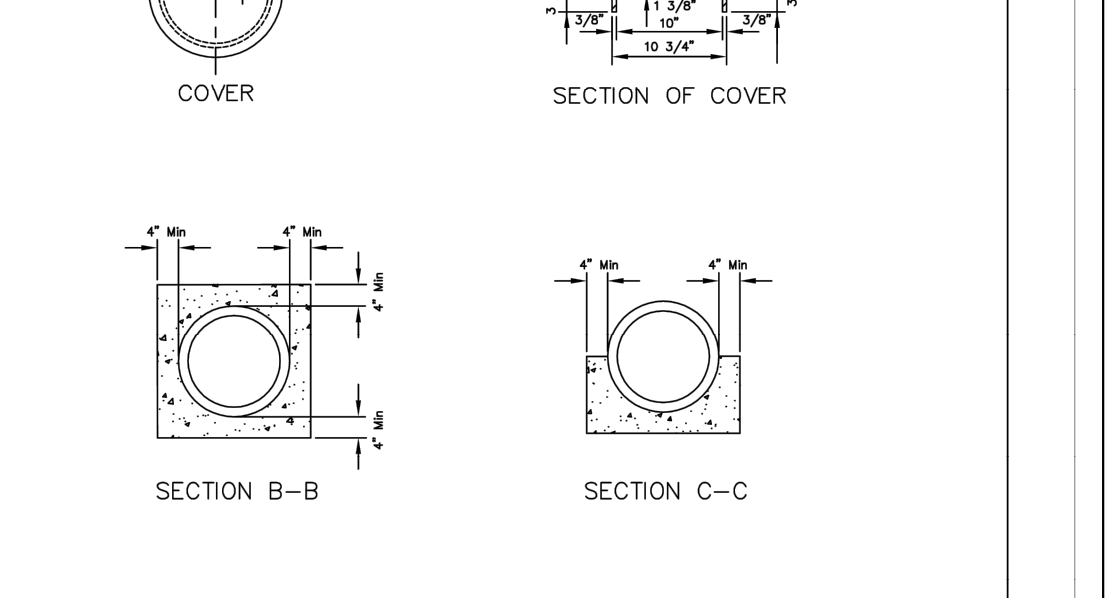
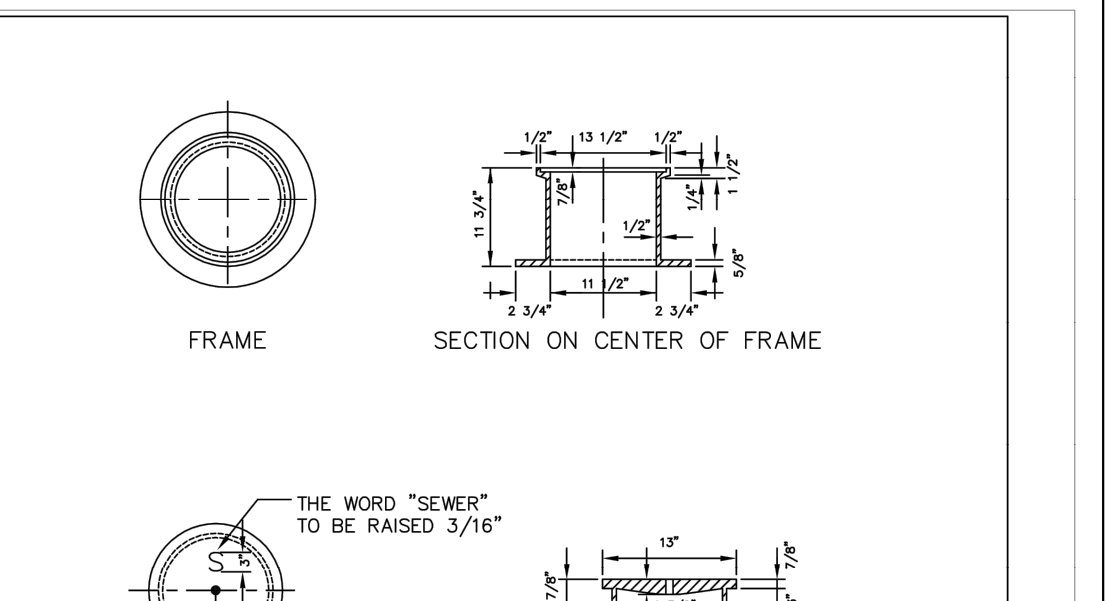

PARKER WATER & SANITATION DISTRICT
IN-LINE CLEANOUT SECTIONS

SECTION B-B

SECTION C-C

SECTION A-A

SCALE: NONE	DATE: 2/96
APPROVED: PVR	2/00 1/16 10/16
DIRECTOR OF ENGINEERING	

SHEET S4.12

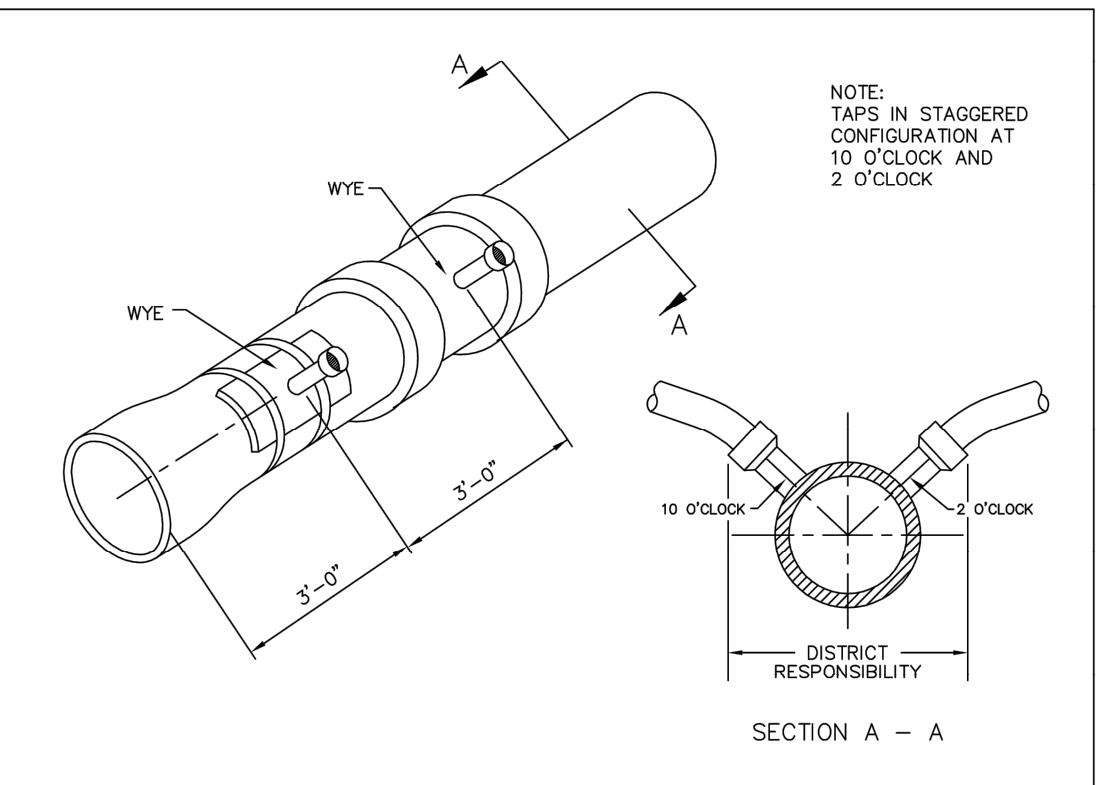

Sewer service connections shall be positioned at either the 2 o'clock or the 10 o'clock position on the circumference of the sewer main. On new installations, tee or wye fittings shall be used. When tapping into existing sewer main, a saddle connection and approved coring method shall be used. The minimum distance between service connections made along the pipe shall be 3 feet. The minimum distance from either the bell or spigot end of a pipe shall be 3 feet. The minimum distance from the center of a manhole to a service connection shall be either 7 feet or the transition point from the manhole trench to the normal pipe trench, whichever is greater. A maximum of 4 sewer service connections shall be allowed per 20 foot length of pipe. In all cases, a specific soils investigation should be conducted to assure that the external loading will be within allowable limits regardless of the number of taps involved.

DOMESTIC SEWER TAPPING DETAIL

PARKER WATER & SANITATION DISTRICT
DOMESTIC SEWER TAPPING DETAIL

SCALE: NONE	DATE: 2/96
APPROVED: PVR	4/01 1/08 1/16 10/16
DIRECTOR OF ENGINEERING	

SHEET S4.13

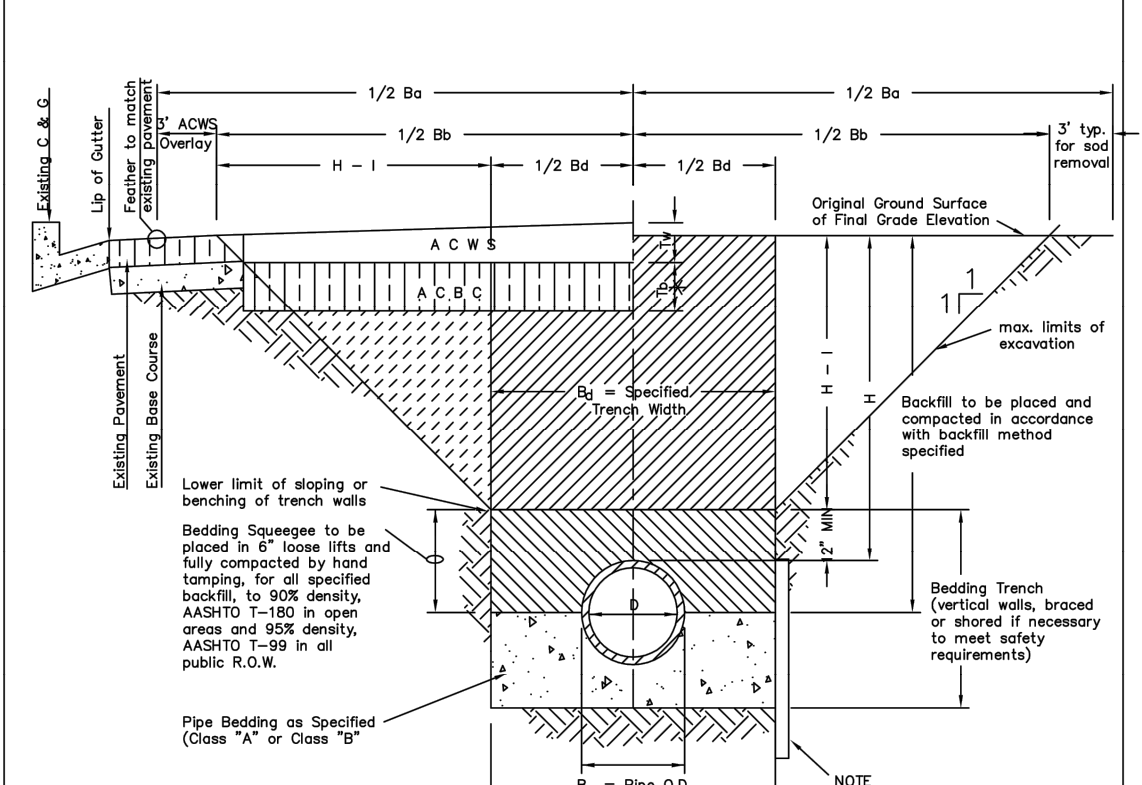

NOTE:
1. Sloping or benching of trench side walls, where permitted shall be in accordance with applicable Federal, State and Local safety regulations.
2. Trench shall be braced and shored as necessary to offset any existing conditions or to protect adjacent utilities, structures, etc. Unless otherwise specified on the plans, no payment will be made for removal, replacement or relocation of curb for removal, gutter, curbs, sidewalks, structures, etc. outside the maximum limits of excavation as shown and the contractor shall be responsible for protection of same.
3. If dimension Bc is < 5', then existing asphalt pavement shall be removed and replaced up to the gutter. Maximum asphalt cur width, Bc & Bw, shall then be based upon this actual width.

PARKER WATER & SANITATION DISTRICT
SEWER TRENCHING AND BEDDING DETAIL

STREET WIDTH	ASPHALTIC BASE COURSE (%)	ASPHALTIC WEARING SURFACE (%)	TOTAL THICKNESS (%)
UP TO 36'	4"	2"	6"
36' TO 44'	4"	3"	7"
44' TO 48'	5"	3"	8"
WIDER THAN 48'	6"	3"	9"

SCALE: NONE	DATE: 2/96
APPROVED: PVR	5/98 1/16 10/16
DIRECTOR OF ENGINEERING	

SHEET S4.1

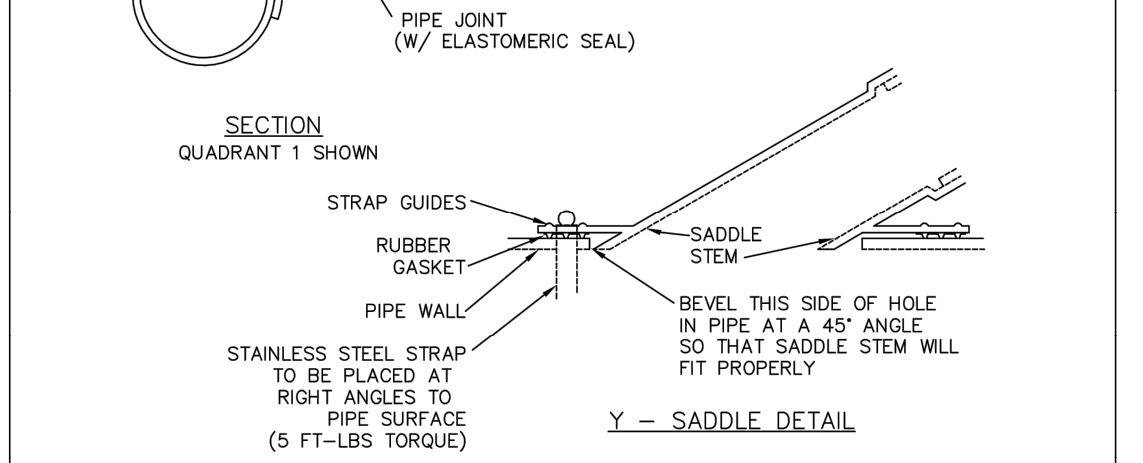
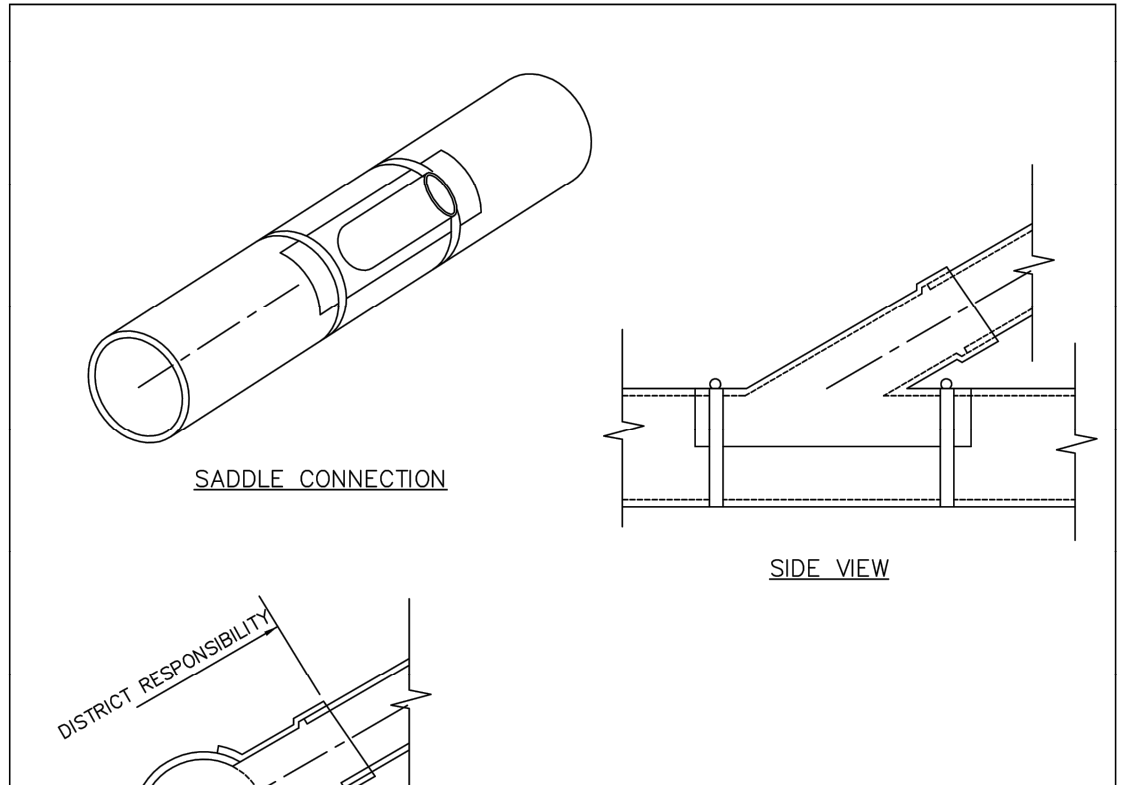

PARKER WATER & SANITATION DISTRICT
P.V.C. SADDLE CONNECTION DETAIL

NOTES:
1. SADDLE FITTINGS TO BE PER ASTM D3034.
2. CONNECTION SHALL BE Y - SADDLE WITH TWO BONDS

SCALE: NONE	DATE: 2/96
APPROVED: PVR	1/16 10/16
DIRECTOR OF ENGINEERING	

SHEET S4.14

NO.	REVISION	BY	DATE	APPR

Kimley»Horn
2020 KIMLEY-HORN AND ASSOCIATES, INC.
4582 South Ulster Street, Suite 1500
Denver, Colorado 80237 (303) 228-2300

DESIGNED BY: DLS
DRAWN BY: JRK
CHECKED BY: DLS
DATE: 12/14/20

PARKER AND PINE FILING NO. 2 LOTS 1-3
PARKER, CO
MULTI-FAMILY CONSTRUCTION DOCUMENTS
UTILITY DETAILS

PRELIMINARY
FOR REVIEW ONLY
NOT FOR CONSTRUCTION
Kimley»Horn
Kimley-Horn and Associates, Inc.

PROJECT NO.
096481002
DRAWING NAME
096481002UT_DT
C7.4

