



Town of Parker Community Development Department
 Development Review Division
 Attention: **Jeremiah Fettig**

Application Type: **Site Plan – Non-Residential**
 Status: **First Referral**
 Application Name: Parker and Pine F1 L4 - Car Wash
 Case/AP#: **SP20-118**
 Referral Received: October 18, 2021
 Comments Due: November 3, 2021

Application Location: Generally located on the southwest corner of Parker Road and Pine Lane

Review date: **October 18, 2021, 2021**
 Plan reviewer: **Randall L. Capra, rcapra@parkeronline.org**
 Phone: 303.805.3163

TOWN OF PARKER - FIRE/LIFE SAFETY:	C REVIEWED FOR CODE COMPLIANCE w/COMMENTS
---	--

- 1st Submittal – Reviewed October 18, 2021
- 2nd Submittal – Reviewed February 28, 2022 (*comments in red, italicized font*)
- 3rd Submittal – Reviewed August 8, 2022 (*comments in bold, red, italicized font*)
- 4th Submittal – Reviewed January 20, 2023 (*comments in bold, red, italicized font with a yellow highlight*)
- 5th Submittal – Reviewed May 1, 2023 (*comments in blue, italicized*)

Narrative: The applicant, Michael Scarborough, is requesting a Site Plan approval for an automatic car wash. The site is located on the west side of Parker Road south of Pine Lane.

Code Reference: 2018 International Fire Code, 2018 International Building Code, 2017 NEC (*adopted codes valid through Dec 31, 2021; projects submitted for building permits will be required to meet the 2021 ICC codes and the 2020 NEC when submitted after December 31, 2021*).

UNRESOLVED ISSUES/COMMENTS

Note – The applicant has not provided a written response to this letter making it difficult to approve the application at the current time. When resubmitting, the applicant either address acknowledgement as “noted”, “acknowledged” or as “addressed”. Modifications to any plan set as a result of the response should also be noted as to the name of the document and the associated pages when resubmitting.

1. The applicant shall be aware that no vertical construction on this site will be allowed until such time that curb gutter and first lift of asphalt are installed; a site inspection will be required to ensure that this requirement is made prior to allowing vertical construction to commence. *Not satisfied; applicant has not noted, acknowledged, or addressed with current submittal. Satisfied; applicant has noted/acknowledged/addressed with the third submittal.*
2. The applicant shall be aware that the Town of Parker has officially adopted the 2018 ICC codes as of January 1, 2019; all submittal documents are required to comply with the 2018 ICC codes. Note – The Town of Parker will have officially adopted the 2021 ICC family on January 1, 2022; the 2020 NEC will be adopted at this time, as well. Any submittals received after December 31, 2021 will be required to meet the newly adopted codes. *Not satisfied; applicant has not noted, acknowledged, or addressed with current submittal. As the application has not progressed quickly, the applicant will now be required to submit all documents under the 2021 ICC code family. Satisfied; applicant has noted/acknowledged/addressed with the third submittal*
3. The Town of Parker requires that fire apparatus access roads meet the clear-width and weight-bearing standards of the jurisdiction in which the project is located. Roadways shall be designed to support the imposed weight of fire apparatus, 30-ton two axle and 40-ton three axle vehicles. An unimpeded clear width of 20-feet shall be maintained at all times. As such, any location where parked vehicles would obstruct this clear width requirement

will require "NO PARKING – FIRE LANE" signage. *This signage shall be red on white. Update design criteria has been provided at the end of this document; ensure compliance when resubmitting.* Note – information on fire lane signage can be found at the end of this document. *As the application has not progressed quickly, the applicant will now be required to submit all documents under the 2021 ICC code family. Satisfied; applicant has noted/acknowledged/addressed with the third submittal*

4. While the applicant has provided the required auto-turn analysis, the analysis does not support an unrestricted flow with regard to the apparatus. The site is required to be designed such that fire apparatus can navigate the site without having to put a vehicle into reverse so as to "jockey" the rig back and forth to make the turn. The applicant shall also be aware that the cab of the apparatus extends approximately 8 feet beyond the front wheels requiring that the apparatus will overhang curbs, etc. when making a turn. Should the applicant have used a standard spec for the auto turn program, the applicant shall revisit these specs to ensure that they comply with the requirements for the apparatus utilized by the response agency for this location. The specs for fire apparatus are provided later in this document; use this information when reworking the required auto-turn analysis as applicable. See below for areas that shall be required to be included in this analysis when resubmitting (it appears that you will be required to eliminate some vacuums and relocated the accessible parking when reworking the analysis): *Not satisfied; applicant has not noted, acknowledged, or addressed with current submittal. A new auto-turn analysis is required. Not satisfied; applicant had indicated that the "auto turn" analysis was provided on "Site Plan". Checking the site plan documents provided, there is not a reference to an auto turn sheet in any index and there is not a sheet that references an auto turn analysis. Address this issue when resubmitting. Not satisfied; applicant had indicated that the "auto turn" analysis was provided on "Site Plan". Checking the site plan documents provided, there is not a reference to an auto turn sheet in any index and there is not a sheet that references an auto turn analysis. Address this issue when resubmitting. Note – Failure to provide the required updated auto turn analysis will result in further delays in approving this project. Not satisfied; applicant has indicated that the auto turn analysis was provided with Sheet C4.2 while only providing documentation of the apparatus spec information provided to the applicant with previous submittal applications. As the site plan has been modified to provide a one way in/one way out scenario, it appears that the site plan will be sufficient to move forward. The applicant, however, will have a responsibility to modify site conditions should access be inadequate for emergency response apparatus.*

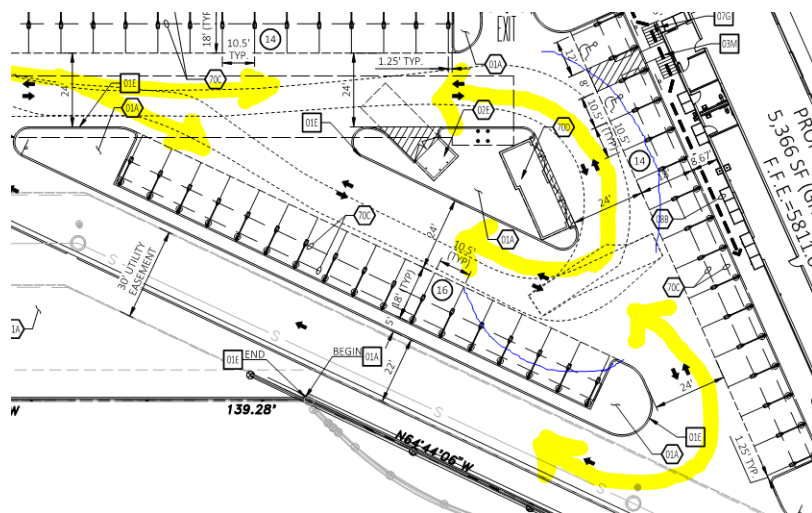

5. The applicant has not provided the required separate Utility Plan for this project; the plan shall ensure that the Overall Utility plan does has the required Fire Life Safety signature block; a Fire Life Safety signature block is required on the cover sheet and the Overall Utility plan (an example of the signature block is provided in the body of this response); the Fire Life Safety signature block is not required on the rest of the utility plan set of other civil or construction documents. *Not satisfied; applicant has not noted, acknowledged, or addressed with current submittal. Satisfied; applicant has noted/acknowledged/addressed with the third submittal*
6. Based upon the size of the building (actual building 153'-0" x 37'-0"), it is not possible for the applicant to provide the required access to all portions of the building, as noted in [18 IFC 503.1.1 Buildings and Facilities]. This section states that "the fire apparatus access road shall comply with the requirements of this section and shall extend to within 150 feet of all portions of the facility and all portions of the exterior walls of the first story as measured by an approved route around the exterior of the building or facility". Based upon the size of the building, 153' + 37' = 190 feet (plus another 40 feet to center of the access that is perpendicular to the building), the access

to all portions of the building would be approximately 230 feet... the requirement cannot be met. *Partially satisfied; applicant has not noted, acknowledged, or addressed with current submittal specific to this response though the plan set does appear to have addressed the fact that the building is required to be sprinklered. The applicant will address all requirements noted in this letter and response both in writing as well as in the documentation when resubmitting. Note – The riser room shall be located closer to the n/w corner of the building... in closer relationship to the required fire hydrant.*

The code does allow the fire code official to extend this access on the basis that the building is fully sprinklered per NFPA 13, as required by [18 IFC 903.1.1]. A sprinkler suppression system, installed in accordance with NFPA 13, is required for this building. *Not satisfied; applicant has noted/acknowledged/addressed with the third submittal though the applicant has stated that this issue is to be “addressed by others”. Clarification as to this response is required. Note - The location of the riser room is acceptable. Satisfied; The riser room location will be accepted for this project.*

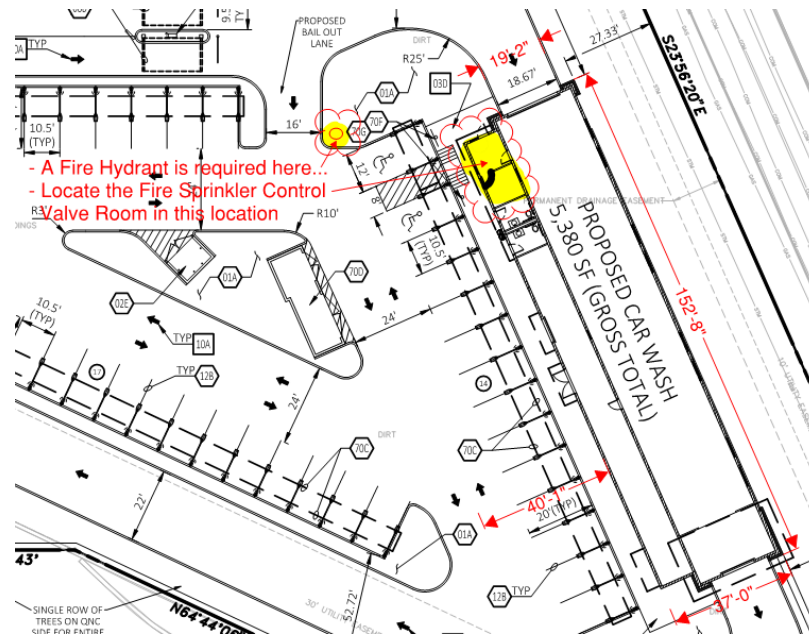

this issue is to be “addressed by others”; this response is not acceptable, and the room layout shall be addressed when resubmitting; deferring this issue is not allowed. Not satisfied; applicant had indicated that this issue is to be “addressed by others”; this response is not acceptable, and the room layout shall be addressed when resubmitting; deferring this issue is not allowed. Satisfied; applicant has addressed with the fifth submittal.

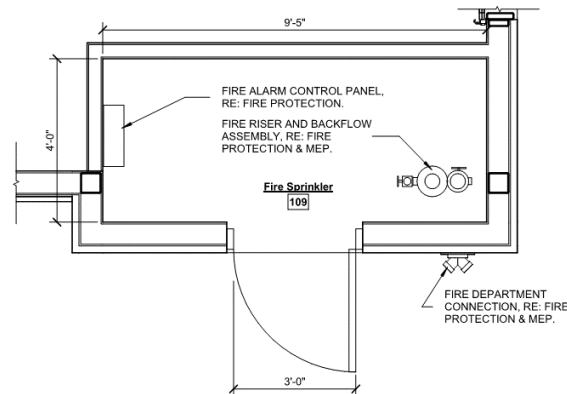

10. The underground fire line shall (UFL) shall be clearly identified on the overall utility drawings; the drawings shall identify the size of the UFL (i.e. 6”) and identify the length, as measured from the “T” at the water main to the flange in the riser room. **Note – domestic and fire hydrant are not allowed to share this line.** Address this issue when resubmitting. **Not satisfied; applicant has not noted, acknowledged, or addressed with current submittal. Satisfied; applicant has noted/acknowledged/addressed with the third submittal**
11. A sidewalk shall be added around the perimeter of the building (east side) for access. Address this issue when resubmitting. **It appears that this issue has been satisfied; applicant has not noted, acknowledged, or addressed specific to this response letter, however. Satisfied; applicant has noted/acknowledged/addressed with the third submittal**
12. **Egress is not shown out of the tunnel; while this is a code issue; doors will be required, and this will end up being a planning issue. Address this issue when resubmitting. Not satisfied; applicant had indicated that this issue will be addressed by others. Deferring the response (providing the egress required) is not acceptable; this issue shall be addressed at this time. Not satisfied; applicant had indicated that this issue will be addressed by others. Deferring the response (providing the egress required) is not acceptable; this issue shall be addressed at this time. Satisfied; applicant has addressed with the fifth submittal.**

GENERAL COMMENTS (as applicable)

All engineering documents submitted to the Town of Parker shall bear the wet signature and seal of the engineer or architect in responsible charge of the design.

Water distribution and site access components shall be installed and in service prior to the construction of any portion of the structure, except by special permit issued by the Fire District.

Underground fire lines

When thrust blocks are used as part of the pipe restraint system, submitted plans for permit shall provide detailed documentation that the thrust blocks satisfy all requirements of 13 NFPA 24: 10.8.2, including specific thrust block dimensions and mathematical calculations for block dimensions per guidelines provided in Annex A.10.8.2.

Underground Fire Line - Submittal Requirements

Reference: 2016 NFPA 24 [Installation of Private Fire Service Mains and Their Appurtenances](#)

A separate permit is required and will be issued pending review of a detailed submittal which must include the following: [18 IFC 901.2]

4.1.1 Working plans shall be submitted for approval to the authority having jurisdiction before any equipment is installed or replaced.

4.1.2 Deviation from approved plans shall require permission of the authority having jurisdiction.

4.1.3 Working plans shall be drawn to an indicated scale on sheets of uniform size, with a plan of each floor as applicable, and shall include the following items that pertain to the design of the system:

- (1) Name of owner
- (2) Location, including street address
- (3) Point of compass
- (4) A graphic representation of the scale used on all plans
- (5) Name and address of contractor
- (6) Size and location of all water supplies
- (7) The following items that pertain to private fire service mains:
 - (a) Size
 - (b) Length
 - (c) Location
 - (d) Material (ductile iron, PVC, etc.)
 - (e) Point of connection to city main
 - (f) Sizes, types, and locations of valves, depth at which the top of the pipe is laid below grade
 - (g) Method of restraint (Meg-a-Lug or similar)
 - (h) Stamped and signed thrust block calculations specific to the soils conditions for the site
 - (i) Copy of the installer's state license

4.1.4 The working plan submittal shall include the manufacturer's installation instructions for any specially listed equipment, including descriptions, applications, and limitations for any devices, piping, or fittings. Submittals must include installation specifications for thrust blocks, corrosion protection, restraint system, bedding, detail of pipe under the building up to, and including, the flange. When it is intended that a different contractor will extend the fire line from a stopping point outside the building, to the inside flange, a second submittal and permit is required.

All plans shall be combined into a single pdf prior to uploading to the Town of Parker website.

All tees, plugs, reducers, valves, and hydrant branches shall be restrained against movement by thrust blocks [10.8.2] or restrained joint systems [10.8.3]. When thrust blocks are used as part of the pipe restraint system, submitted plans shall provide detailed documentation that the thrust blocks satisfy all requirements of Section 10.8.2, including specific thrust block dimensions and mathematical calculations for block dimensions per guidelines provided in Annex A.10.8.2.

Any individual or company who physically works on or installs any part of a fire suppression system, including underground supply lines, from public water lines to system risers and backflow preventers, **must** be registered with the Colorado Division of Fire Safety. [Dept. of Public Safety, Division of Fire Safety, Fire Suppression Program 8 CCR 1507-11:3.1.2] Documentation of valid annual registration is required with plan submittal.

The following website for the Colorado Division of Fire Safety will provide registration instructions.

<http://dfs.state.co.us/SuppAppsProclnsp.htm>

All submittals must display a wet stamp and original signature by a Colorado licensed professional engineer or NICET III, or higher, in fire suppression systems. [Dept. of Public Safety, Division of Fire Safety, Fire Suppression Program 8 CCR 1507

FIRE CODE REVIEW/SIGNATURE BLOCK

All fire hydrants shall be installed according to water utility standards. The number and locations of the fire hydrants as shown on the Overall Utility Plan are correct as specified by the Town of Parker, Community Development Department.

Fire Code Official or Designated Representative

Date

(NOTE - Underground Fire Line (UFL) submittal documents must meet the requirements of NFPA 24 when submitting for review.)

FIRE ACCESS ROAD DESIGN CRITERIA

VEHICLE SPECIFICATIONS are provided for the largest apparatus in use by South Metro Fire Rescue. Fire Apparatus Access Roads shall be capable of accommodating this apparatus.

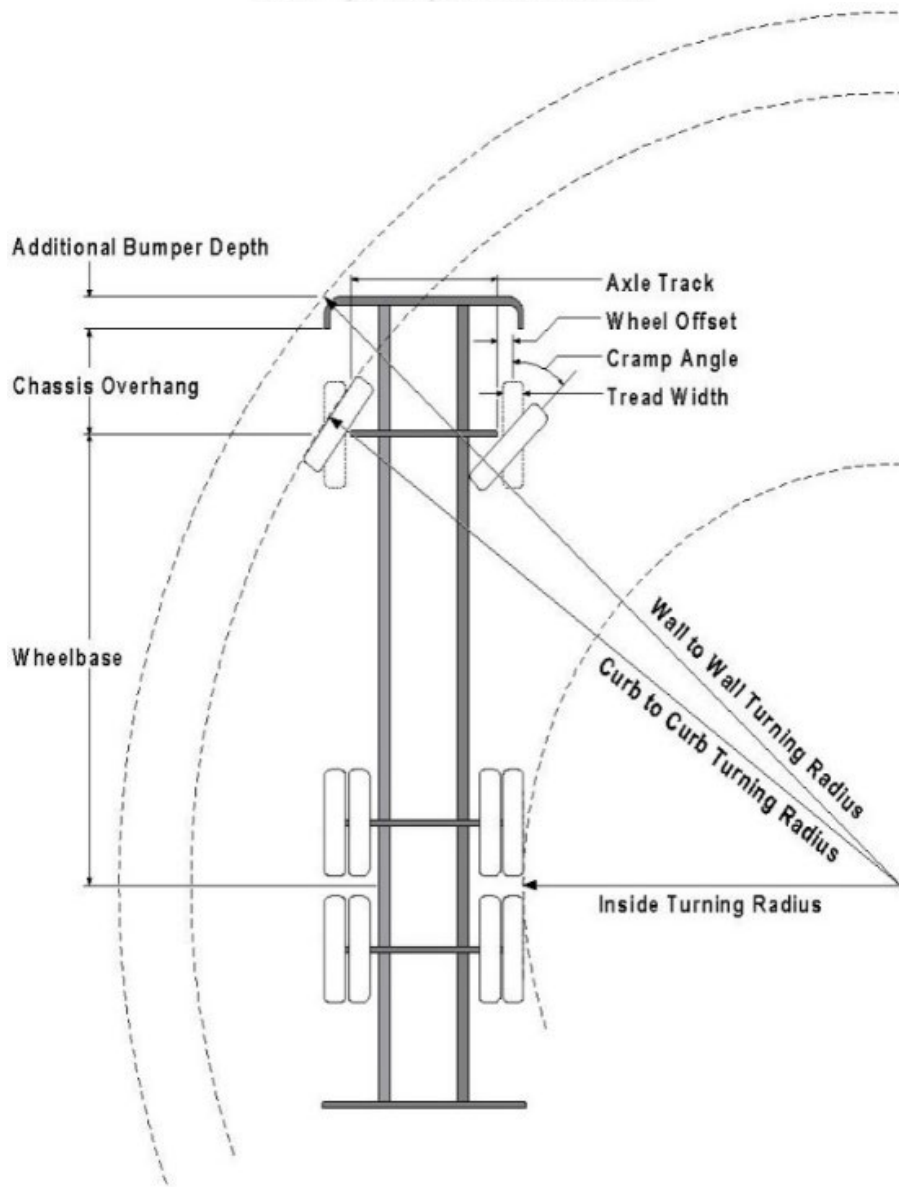
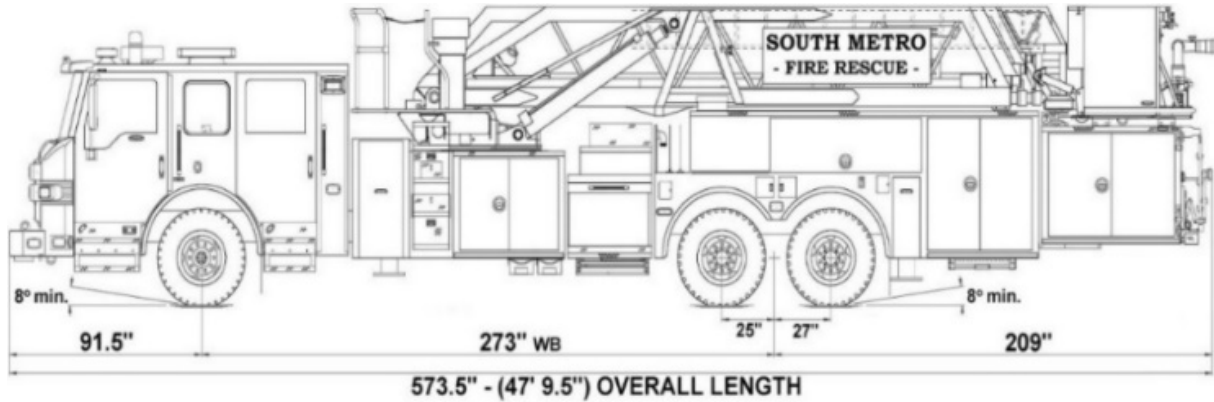

Vehicle Specifications

Length: 47' 9.5"

Width: 8' 5" - (10' 1" mirror to mirror)

Height: 10' 9"

Wheelbase: 273 in.

Design load: 80,000 pounds

Inside Cramp Angle: 40°

Axle Track: 83"

Wheel Offset: 5.3"

Tread Width: 13.5"

Turning Radii:

Inside Turn: 26 ft. 1 in.

Curb to curb: 41 ft. 11 in.

Wall to wall: 46 ft. 8 in.

Where objects are present adjacent to the fire apparatus access road, particularly on turns and turn arounds which require backing, a reasonable safety margin shall be provided to prevent potential damage to the property and to the fire apparatus.

PRIVATE ROADS that provide access to more than two dwellings or one or more commercial buildings shall be constructed to meet the roadway standards approved by the South Metro Fire Rescue Authority for fire apparatus access. Private roads that do not meet the roadway standard may be accepted provided that alternative methods and materials are incorporated into the subdivision that addresses the fire and life safety of the citizens.

FIRE LANE SIGN PLACEMENT

Posting of Fire Lanes: The posting of the "Fire Lanes" is required.

Fire Lane Sign Dimensions. NO PARKING – FIRE LANE signs shall be 12 inches wide and 18 inches high.

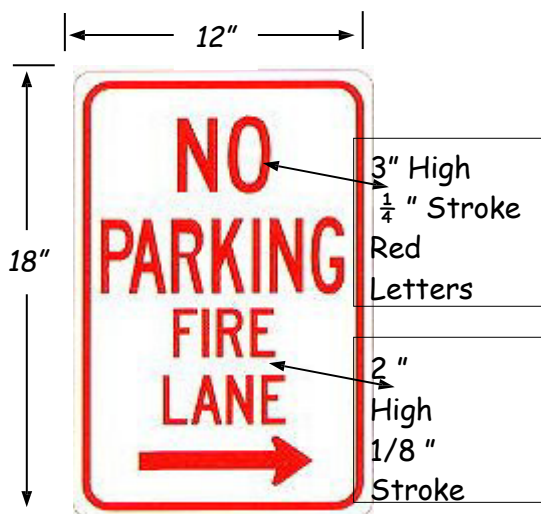

Fire Lane Sign Characteristics: Signs shall be engineer grade reflective sheeting on 0.80 aluminum with red lettering on a white background.

Fire Lane Sign Locations. Fire apparatus access roadways between 20 and 28 feet wide, signs shall be posted on *both sides*. Fire apparatus access roadways between 28 feet wide and 34 feet wide, signs may be posted on *one side only*.

Fire Lane Sign Installation. NO PARKING – FIRE LANE signs shall be installed as follows:

1. Bottom edge of the signs shall be 7 feet above surface (sidewalk) and post shall be placed 24 inches from flow line (curb).
2. One sign at the beginning of the restriction (one arrow pointing towards the restriction zone).
3. One sign at the end of the restriction (one arrow pointing back into restricted zone).
4. One sign at least every 150 ft. within the restricted area (double arrow pointing in each direction, to indicate the continuing restriction).
5. Spaced evenly within the restriction (for straight curbs/zones). For example, if the parking restriction zone is 300 ft long, only one double arrow sign is required at a distance of 150 ft. from the beginning of the restriction. If the restriction zone is 400 ft. long, two double arrow signs are required; spaced 100 ft. evenly from each other and from the beginning/ending signs.
6. Spaced so that at least one readable sign is visible in front of a parked vehicle from any point along the restriction (for curved curbs/zones and areas that may present visual obstacles.)
7. Set at an angle of no fewer than 30 degrees and no more than 45 degrees with the lane of traffic flow visible to approaching traffic.
8. Signs shall be provided at all normal and emergency access points to structures and within 20 feet of each fire hydrant and fire department connection (FDC) in compliance with UFC 901.4.2.
9. Some areas may need additional fire lane signs. Check with the Division of Life Safety for any additional requirements.

Fire Lane Sign Types. The diagrams below indicate the types of signs that may be used, and the recommended placement.

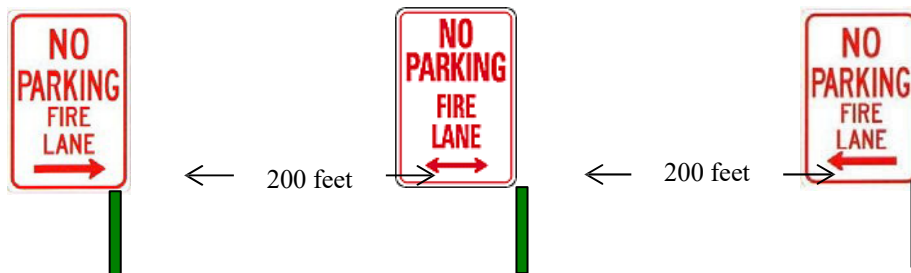

Additional sign styles may be used – provided the same type is used consistently.



Painting of Curbs or Streets. In addition to the required signage, South Metro Fire Rescue does permit fire lanes to be painted with curb or street markings. However, these markings shall not replace the required fire lane signs. Curbs may be painted red with 3-inch white block letters stating **NO PARKING – FIRE LANE**. Lettering shall be spaced every 15 feet.