



CONSULTANTS:

2435 RESEARCH PARKWAY, SUITE 300  
COLORADO SPRINGS, CO 80920  
PHONE: (719) 575-0100  
FAX: (719) 575-0208

950 S. CHERRY STREET, SUITE 512  
DENVER, CO 80246

OWNER/DEVELOPER:

ROCKY MOUNTAINS DIVISION  
5500 S. QUEBEC STREET, SUITE 100  
GREENWOOD VILLAGE, CO 80111

SEAL

FOR AND ON BEHALF OF MATRIX DESIGN GROUP, INC.  
CONTRACTOR IS RESPONSIBLE FOR OBTAINING THE  
MOST RECENT PROJECT CONSTRUCTION DOCUMENTS.  
MATRIX DESIGN GROUP IS NOT RESPONSIBLE FOR  
CHANGES, ALTERATIONS, OR USE OF CONSTRUCTION  
DOCUMENTS PRIOR TO JURISDICTIONAL APPROVAL.

VICINITY MAP: SCALE: NTS

PROJECT:

**CIRCLE K**

**CONSTRUCTION DOCUMENTS**

16846 E AUBURN HILLS DRIVE  
PARKER, CO 80134

REVISION HISTORY:

NO.	DATE	DESCRIPTION	BY

DRAWING INFORMATION:

PROJECT NO: 21.1207.030  
DRAWN BY: KMZ  
CHECKED BY: NMS  
DESIGNED BY: KMZ  
SHEET TITLE:

**COVER SHEET**

**C0.0**

**SHEET 1 OF 26**

DATE: NOVEMBER 2022

# CIRCLE K CONSTRUCTION DOCUMENTS

SE CORNER OF COMMERCIAL LOT 1- PHASE II, FILING NO. 3B OF BRADBURY RANCH  
LOCATED IN THE NORTHEAST 1/4 OF THE SOUTHEAST 1/4 OF SECTION 20, TOWNSHIP 6 SOUTH,  
RANGE 66 WEST OF THE 6TH P.M.,  
TOWN OF PARKER, STATE OF COLORADO

CONTACT LIST

<b>OWNER</b> WDG JORDAN, LLC 4201 E YALE AVE, STE 140 DENVER, CO 80222 PHONE: (303) 848-2827	<b>TOWN OF PARKER - COMMUNITY DEVELOPMENT DEPARTMENT</b> 20120 E. MAINSTREET PARKER, CO 80138 JOHN FUSSA PHONE: (303) 841-2332
<b>DEVELOPER</b> LAND DEVELOPMENT CONSULTANTS, LLC 950 S. CHERRY STREET, SUITE 512 DENVER, CO 80246 SOFIA HERNANDEZ PHONE: (303) 717-3305	<b>PARKER WATER &amp; SANITATION</b> 18100 E WOODMAN DR, PARKER, CO 80134 PHONE: (303) 841-4627
<b>CIVIL ENGINEER/ LANDSCAPE ARCHITECT</b> MATRIX DESIGN GROUP 2435 RESEARCH PARKWAY, SUITE 300 COLORADO SPRINGS, CO 80920 NICOLE SCHANEL/ JASON ALWINE PHONE: (719) 575-0100	<b>SOUTH METRO FIRE RESCUE</b> PHONE: (720) 989-2000
<b>ARCHITECT</b> GREENBERG FARROW 30 EXECUTIVE DRIVE, SUITE 100 IRVINE, CA 92614 ARMON BACOLOD PHONE: (949) 296-0450	<b>XCEL ENERGY</b> PHONE: 1-800-895-4999
<b>LAND SURVEYOR</b> RUBINO SURVEYING 3312 AIRPORT ROAD BOULDER, CO 80301 PHONE: (303) 464-9515	<b>CORE ELECTRIC COOPERATIVE</b> PHONE: (800) 332-9540
	<b>GEOTECHNICAL ENGINEER</b> KUMAR & ASSOCIATES, INC. 2390 SOUTH LIPAN STREET DENVER, CO 80223 PHONE: (303) 742-9700

GENERAL COVER SHEET NOTES

- FENCES, WALLS, SIGNS AND ACCESSORY STRUCTURES ARE SUBJECT TO SEPARATE REVIEWS AND PERMITS.
- ANGLES NOT SHOWN ARE EITHER 90 DEGREES OR A SUPPLEMENT OF THE ANGLE INDICATED.
- PRIVATE ROADWAYS WILL BE POSTED WITH "FIRE LANE" SIGNS AS REQUIRED BY THE SOUTH METRO FIRE RESCUE.
- PARKING SPACES FOR PERSONS WITH DISABILITIES WILL BE CLEARLY DELINEATED WITH UPRIGHT SIGNS.
- APPROVAL FOR THIS PLAN DOES NOT CONSTITUTE OR IMPLY COMPLIANCE WITH ADA REQUIREMENTS.
- SITE(S) SHALL BE LANDSCAPED PRIOR TO ISSUANCE OF A FINAL CERTIFICATE OF OCCUPANCY (CO) DURING THE GROWING SEASON OF APRIL 1ST TO OCTOBER 1ST, AT ALL OTHER TIMES THE INDIVIDUAL SITES SHALL BE LANDSCAPED WITHIN 45 (FORTY-FIVE) DAYS OF THE START OF THE FOLLOWING GROWING SEASON.
- AN ACCESS EASEMENT FOR EMERGENCY SERVICES IS HEREBY GRANTED ON AND ACROSS ALL AREAS FOR POLICE, FIRE, MEDICAL AND OTHER EMERGENCY VEHICLES AND FOR THE PROVISION OF EMERGENCY SERVICES.
- ALL LANDSCAPE AREAS SHALL BE IRRIGATED WITH UNDERGROUND AUTOMATIC IRRIGATION SYSTEM. TREES, SHRUBS, AND DECORATIVE GRASSES WILL BE IRRIGATED BY A SEPARATE ZONE FROM SOD/GRASS. THIS INCLUDES TREES PLANTED IN SOD/GRASS AREA. THE IRRIGATION SYSTEM IS TO HAVE A RAIN SENSOR SHUT-OFF INSTALLED.
- PRIVATE ROADWAYS ARE NON-DEDICATED STREETS AND WILL NOT BE MAINTAINED BY THE TOWN OF PARKER.

NOTES

SEE ARCHITECTURAL PLANS FOR EXACT LOCATIONS AND DIMENSIONS OF PORCHES, RAMPS, SLOPED PAVING, TRUCK DOCKS, BUILDING UTILITY ENTRANCE LOCATIONS, AND PRECISE BUILDING DIMENSIONS

BEARING

BEARINGS: BASED ON THE NORTH LINE OF THE SOUTHEAST 1/4 OF SECTION 20 ASSUMED TO BEAR N89°25'39"E BETWEEN MONUMENTS FOUND AND DESCRIBED ON THE ALTAINSPS LAND TITLE SURVEY BY RUBINO SURVEYING DATED 06/08/2020

NOTICE TO BIDDERS

ALL QUESTIONS REGARDING THE PREPARATION OF THE GENERAL CONTRACTOR'S BID SHALL BE DIRECTED TO THE OWNER'S CONSTRUCTION DEPARTMENT AT (602) 850-8101. SUBCONTRACTORS MUST DIRECT THEIR QUESTIONS THROUGH THE GENERAL CONTRACTOR. THE CONSULTING ARCHITECT AND/OR THE CONSULTING ENGINEER SHALL NOT BE CONTACTED DIRECTLY WITHOUT PRIOR AUTHORIZATION FROM THE OWNER/DEVELOPER

FLOOD ZONE INFORMATION

ACCORDING TO THE FEDERAL EMERGENCY MANAGEMENT AGENCY (FEMA) RATE MAP COMMUNITY PANEL NO. 08035C0068G, DATED MARCH 16, 2016, THIS PROPERTY IS IN FLOOD HAZARD ZONE X "AREAS DETERMINED TO BE OUTSIDE THE 0.2% ANNUAL CHANCE FLOODPLAIN"

LEGAL DESCRIPTION

A PORTION OF THAT PARCEL OF LAND KNOWN AS BRADBURY RANCH COMMERCIAL LOT 1 AND A PORTION OF THAT RIGHT-OF-WAY DESCRIBED AS PARCEL IV IN SPECIAL WARRANTY DEED RECORDED ON OCTOBER 14, 1987 IN BOOK 753, PAGE 617 OF THE RECORDS OF DOUGLAS COUNTY, BEING SITUATE IN THE SOUTHEAST QUARTER (SE 1/4) OF SECTION TWENTY (20), TOWNSHIP SIX SOUTH (T. 6S.), RANGE SIXTY-SIX WEST (R. 66W.) OF THE SIXTH PRINCIPAL MERIDIAN (6<sup>TH</sup> P.M.), TOWN OF PARKER, COUNTY OF DOUGLAS, STATE OF COLORADO, AND MORE PARTICULARLY DESCRIBED AS FOLLOWS:

COMMENCING AT THE EAST QUARTER CORNER OF SAID SECTION 20 AND ASSUMING THE EAST LINE OF SAID SE1/4 AS BEARING SOUTH 00°21'15" EAST, BEING A GRID BEARING OF THE COLORADO STATE PLANE COORDINATE SYSTEM, CENTRAL ZONE, NORTH AMERICAN DATUM 1983, WITH ALL OTHER BEARINGS CONTAINED HEREIN BEING RELATIVE THERE TO:

THE LINEAL DIMENSIONS AS CONTAINED HEREIN ARE BASED UPON THE "U.S. SURVEY FOOT."

THENCE SOUTH 00°21'15" EAST A DISTANCE OF 70.00 FEET TO THE SOUTH LINE OF BRADBURY RANCH SUBDIVISION FILING NO. 2K RECORDED OCTOBER 1, 1997 AT RECEPTION NO. 9754676 OF THE RECORDS OF DOUGLAS COUNTY;  
THENCE SOUTH 88°58'38" WEST ALONG SAID SOUTH LINE A DISTANCE OF 94.78 FEET; THENCE SOUTH 45°37'01" EAST A DISTANCE OF 43.32 FEET;  
THENCE SOUTH 00°21'15" EAST A DISTANCE OF 187.00 FEET TO THE POINT OF BEGINNING;

THENCE CONTINUING SOUTH 00°21'15" EAST A DISTANCE OF 108.63 FEET;  
THENCE SOUTH 00°05'09" EAST A DISTANCE OF 34.05 FEET TO A POINT ON A CURVE CONCAVE TO THE WEST AND BEING NON-TANGENT TO THE AFORESAID LINE A DISTANCE OF 96.74 FEET, SAID CURVE HAS A RADIUS OF 898.98 FEET, A DELTA OF 6°09'57", AND IS SUBTENDED BY A CHORD BEARING SOUTH 01°58'23" WEST A DISTANCE OF 96.70 FEET;  
THENCE SOUTH 48°27'30" WEST NON-TANGENT FROM THE AFORESAID CURVE A DISTANCE OF 55.70 FEET TO THE NORTH RIGHT-OF-WAY LINE OF EAST AUBURN HILLS PLACE PER BRADBURY RANCH SUBDIVISION FILING NO. 3B RECORDED JULY 5, 2000 AT RECEPTION NO. 00046266 OF THE RECORDS OF DOUGLAS COUNTY AND TO A POC;  
THENCE ALONG SAID NORTH RIGHT-OF-WAY LINE AND ALONG THE ARC OF A CURVE CONCAVE TO THE SOUTH AND BEING NON-TANGENT TO THE AFORESAID LINE A DISTANCE OF 207.70 FEET; SAID CURVE HAS A RADIUS OF 1537.50 FEET, A DELTA OF 07°44'25", AND IS SUBTENDED BY A CHORD BEARING SOUTH 85°28'18" WEST A DISTANCE OF 207.54 FEET;

THENCE NORTH 00°21'15" WEST A DISTANCE OF 233.96 FEET; THENCE NORTH 10°22'55" EAST A DISTANCE OF 58.14 FEET;  
THENCE NORTH 89°38'45" EAST A DISTANCE OF 242.16 FEET TO THE POINT OF BEGINNING.

SAID PARCEL CONTAINS 1.597 ACRES OR 69,547 SQ. FT. MORE OR LESS (+/-), AND IS SUBJECT TO ANY RIGHTS-OF-WAY OR OTHER EASEMENTS OF RECORD AS NOW EXISTING ON SAID DESCRIBED PARCEL OF LAND.

GENERAL NOTES

- SURVEY INFORMATION AND TOPOGRAPHIC CONTOURS WERE PROVIDED BY OTHERS. MATRIX DESIGN GROUP, INC. SHALL NOT BE HELD LIABLE FOR ANY INACCURACY IN THE SURVEY INFORMATION.

ENGINEER'S STATEMENT:

THESE DETAILED PLANS AND SPECIFICATIONS WERE PREPARED UNDER MY DIRECTION AND SUPERVISION. THIS CONSTRUCTION PLAN COMPLIES WITH ALL TOWN OF PARKER DESIGN STANDARDS WITH THE MOST CURRENT STANDARD CONSTRUCTION SPECIFICATION AND STANDARD DETAILS

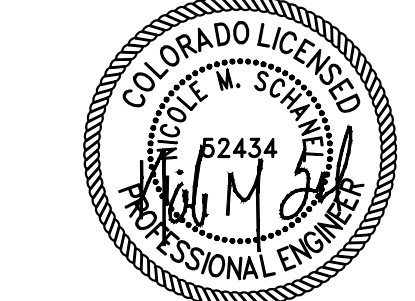

FOR AND ON BEHALF OF MATRIX DESIGN GROUP, INC.  
NICOLE M. SCHANEL, PE# 52434

**NOTE: CONTRACTOR SHALL PROTECT ALL EXISTING SURVEY MONUMENTATION. CONTRACTOR SHALL HAVE LICENSED SURVEYOR REPLACE ANY DAMAGED OR DISTURBED MONUMENTATION AT THEIR COST.**

**THE LOCATIONS OF EXISTING ABOVE GROUND AND UNDERGROUND UTILITIES ARE SHOWN IN AN APPROXIMATE WAY ONLY. THE CONTRACTOR SHALL DETERMINE THE EXACT LOCATION OF ALL EXISTING UTILITIES BEFORE COMMENCING WORK. THE CONTRACTOR SHALL BE FULLY RESPONSIBLE FOR ANY AND ALL DAMAGES WHICH MIGHT BE CAUSED BY THEIR FAILURE TO EXACTLY LOCATE AND PRESERVE ANY AND ALL ABOVE GROUND AND UNDERGROUND UTILITIES.**

The Town of Parker review constitutes general compliance with the Town's Standards and approved variances, subject to these plans being stamped, signed, and dated by the professional engineer of record. Review by the Town does not constitute approval of the plan design or accuracy and correctness of engineering calculations. Errors in the design or calculations remain the responsibility of the registered professional engineer whose stamp and signature are affixed to this document.

This review does not constitute approval of any private on-site improvements which may be shown. Construction cannot commence until all required drainage/traffic reports(s), final development plan(s), special review(s), grading permit, and/or other permits are complete, approved and on file with the Town of Parker.

Town of Parker, Director of Engineering \_\_\_\_\_ Date \_\_\_\_\_

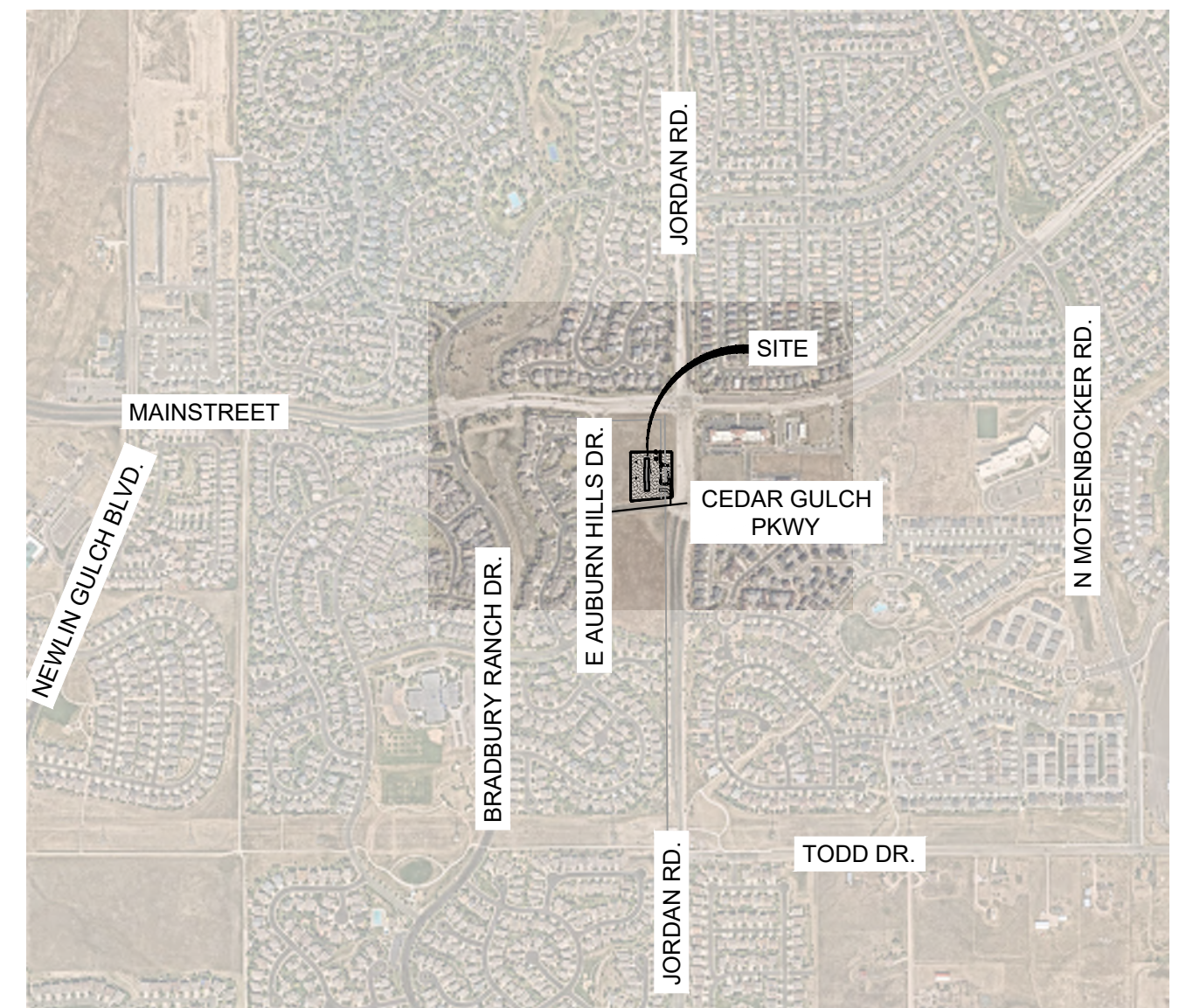

VICINITY MAP  
1" = 1000'

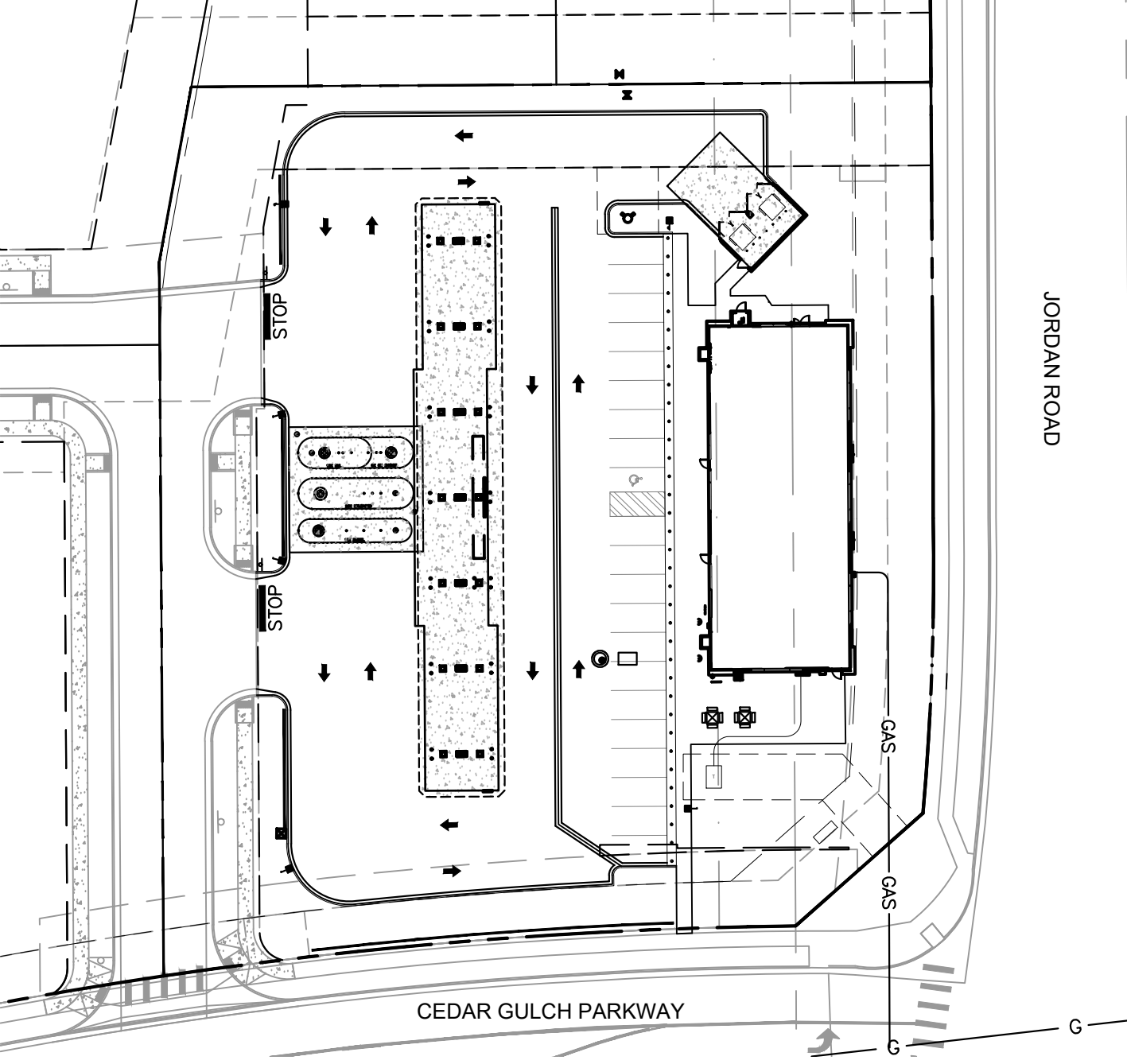

SITE MAP  
1" = 50'

FILE LOCATION: \\CIRCLE K\KUMAR & JORDAN\100-DWG\100-PLAN SETS\CONSTRUCTION PLANS\CSD1.DWG

**CIRCLE K**  
**CONSTRUCTION DOCUMENTS**  
 SE CORNER OF COMMERCIAL LOT 1- PHASE II, FILING NO. 3B OF BRADBURY RANCH  
 LOCATED IN THE NORTHEAST ¼ OF THE SOUTHEAST ¼ OF SECTION 20, TOWNSHIP 6 SOUTH,  
 RANGE 66 WEST OF THE 6TH P.M.,  
 TOWN OF PARKER, STATE OF COLORADO



2435 RESEARCH PARKWAY, SUITE 300  
 COLORADO SPRINGS, CO 80920  
 PHONE : (719) 575-0100  
 FAX : (719) 575-0208



**LAND DEVELOPMENT**  
 CONSULTANTS, LLC

950 S. CHERRY STREET, SUITE 512  
 DENVER, CO 80246

OWNER/DEVELOPER:



ROCKY MOUNTAINS DIVISION  
 5500 S QUEBEC STREET, SUITE 100  
 GREENWOOD VILLAGE, CO 80111

SEAL

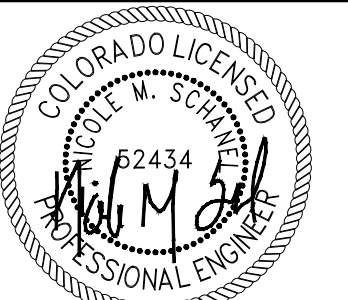

FOR AND ON BEHALF OF MATRIX DESIGN GROUP, INC  
 CONTRACTOR IS RESPONSIBLE FOR OBTAINING THE  
 MOST RECENT PROJECT CONSTRUCTION DOCUMENTS.  
 MATRIX DESIGN GROUP IS NOT RESPONSIBLE FOR  
 CHANGES, ALTERATIONS, OR USE OF CONSTRUCTION  
 DOCUMENTS PRIOR TO JURISDICTIONAL APPROVAL.

VICINITY MAP: SCALE: NTS

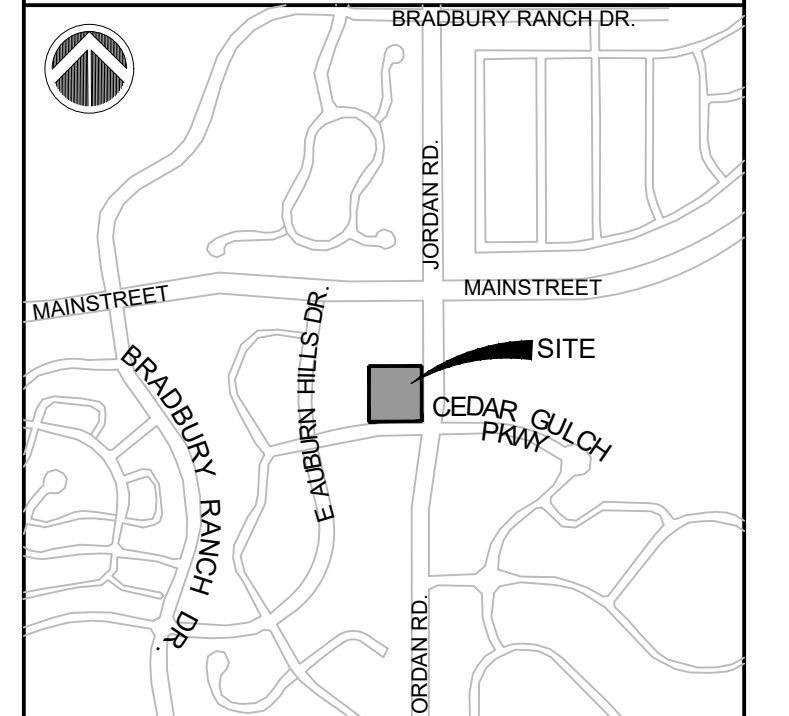

PROJECT:

**CIRCLE K**  
**CONSTRUCTION DOCUMENTS**

16846 E AUBURN HILLS DRIVE  
 PARKER, CO 80134

REVISION HISTORY:

NO.	DATE	DESCRIPTION	BY

DRAWING INFORMATION:

PROJECT NO. 21.1207.030

DRAWN BY: KMZ

CHECKED BY: NMS

DESIGNED BY: KMZ

SHEET TITLE:

**TOWN OF PARKER**  
**GENERAL NOTES**

**C0.1**

SHEET 2 OF 26

DATE: NOVEMBER 2022

**STANDARD CONSTRUCTION NOTES**

- All materials and construction shall be in conformance with the latest edition of the Colorado Department of Transportation Standard Specifications for Road and Bridge Construction, the latest edition of the Town of Parker Roadway Design and Construction Criteria Manual, and the Town of Parker Storm Drainage and Environmental Criteria Manual.
- All materials and workmanship shall be subject to inspection by the Town of Parker Public Works Department. The Town reserves the right to accept or reject any such materials and workmanship that does not conform to its standards and specifications.
- A preconstruction meeting shall be scheduled a minimum of 48 hours and a maximum of 96 hours prior to the start of construction. A preconstruction meeting will not be scheduled until the grading permit and all other necessary permits have been obtained.
- The Town Inspector shall be contacted a minimum of 24 hours prior to a necessary inspection. If a Town Inspector is not available after proper notice of construction activity has been provided, the permittee may commence work in the Town Inspector's absence. However, the Town of Parker reserves the right to reject the improvement if subsequent testing reveals an improper installation.
- Location of existing utilities shall be verified by the contractor prior to actual construction in accordance with all state and local laws. The contractor shall field verify size and horizontal and vertical locations of existing facilities prior to construction, and notify the engineer of any discrepancies.
- The contractor shall have one (1) signed copy of the plans, approved by the Town of Parker Director of Engineering/Public Works, and one (1) copy of the Roadway Design and Construction Criteria at the job site at all times.
- A plan for traffic control during construction shall be submitted to the Town of Parker for acceptance with the Right-of-Way Use Permit application. A permit will not be issued without an approved traffic control plan for use during construction.
- All trenches shall be adequately supported and the safety of workers provided for as required by the most recent Occupational Safety and Health Administration (OSHA) "Safety and Health Regulations for Construction."
- Compaction of all trenches must be attained and compaction test results submitted to the Development Review Engineer in preliminary form prior to paving and in final form prior to probationary acceptance.
- The contractor is responsible for implementing and maintaining erosion and sediment control measures at all times during construction. The plan may be modified as field conditions warrant with approval from the Town of Parker Public Works Department.
- The contractor shall provide, erect and maintain proper traffic control devices until the site is open to traffic. The contractor shall submit a traffic control plan to the Town of Parker Public Works Department for approval prior to construction.
- Plans are approved for period of 1 (one) year from the date shown on the Town of Parker signature block. Plans shall be resubmitted to the Town for approval after 1 year. The cost of the plan re-review and re-acceptance will be charged back to the developer including all time and expenses of the Town of Parker Public Works Department.
- Repair of any damage to existing improvements or landscaping is the responsibility of the contractor. Such restoration may be required to be completed prior to acceptance of completed improvements.
- All damaged existing curb, gutter, and sidewalk shall be repaired prior to acceptance of completed improvements.
- All construction activities must comply with the State of Colorado permitting process for "Stormwater Discharges Associated with Construction Activity." For information, please contact Colorado Department of Health, Water Quality Control Division, WQCD-PE-B2, 4300 Cherry Drive South, Denver, Colorado 80222-1530. Attention: Permits and Enforcement Section. Phone (303) 692-3500.
- If dewatering is required, a state construction dewatering discharge permit is required for discharges to a storm sewer, channel, irrigation ditch, any street that is tributary to the aforementioned facilities, or any water of the United States.
- All references to books, pages, maps, and reception number are public documents on file with the County Clerk and Recorder's Office.

**STORM DRAINAGE INFRASTRUCTURE NOTES**

- All storm drainage improvements are subject to compliance with the Colorado Department of Transportation (CDOT) current edition of the Standard Specifications for Road and Bridge Construction, M & S Standards, and all standard special provisions currently used by CDOT, with the modifications set forth in the Town of Parker's Storm Drainage and Environmental Criteria Manual (SDECM), as amended.
- The contractor shall comply with the "Colorado Water Quality Control Act" (Title 25, Article 8 CRS), the "Protection of Fishing Streams" Title 33, Article 5, CRS), the "Clean Water Act" (33 USC 1344), Cherry Creek Reservoir Control Regulation No. 72" (5 CCR 1002-72), the regulation promulgated, certification or permits issues, and the requirements presented in the SDECM Revision to Section 107 and the Construction BMP Plan. In the event of conflicts between these requirements and water quality control laws, rules, or regulations of other Federal, or State agencies, the more restrictive laws, rules, or regulations shall apply.
- Inspections: Construction shall not begin until a grading permit has been issued for the project. The contractor shall notify the Town of Parker Engineering Department (Public Works) to schedule inspections a minimum of 48 hours prior to the construction of all drainage infrastructure (storm sewers, inlets, manholes, energy dissipaters, riprap, grouted boulders, detention pond outlet structures, forebays, trickle channels, etc). Failure to notify the engineering department for inspections may result in non-acceptance of the infrastructure by the Town. Urban Drainage and Flood Control District must also be notified in a similar manner for all maintenance eligible drainage infrastructures (consult with Stormwater Engineering Division).
- Structural backfill (CDOT Class 1) shall be compacted to conform to CDOT Standard Specification 203.03. Structural backfill (CDOT Class 2) shall conform to CDOT Standard Specification 203.07. At the contractor's option, Structural Backfill (Squeegee) meeting the gradation requirements contained in Revision of Section 206 of the CDOT Standard Specifications as presented in the SDECM, may be substituted for Structure backfill (Class 1 or Class 2) for backfilling of culvert pipes, storm sewer pipes, manholes and inlet structures; however, the top 2 feet below subgrade elevation shall be the required embankment material.
- All excavations shall meet OSHA requirements.
- Testing: Probationary acceptance of storm drainage improvements will be contingent upon satisfactory testing results. In all cases where tests indicate compaction less than that required by Town specifications, additional compaction and tests will be required until the specifications are met. Frequency of testing will be as follows:
  - 1 test for subgrade and 1 test for backfill at every above ground appurtenance (manholes, inlets, etc)
  - 1 test every 200 LF of mainline trench every 1 foot of backfill lift and within 1 foot from all structures.
- Allowable storm sewer conduit material within the Town of Parker shall be limited to Reinforced Concrete Pipe (RCP) conforming to CDOT Standard Specification 706.02.
- All RCP joints shall be manufactured in accordance with ASTM C443. Rubber gaskets shall be used on all pipe joints conforming to ASTM C443. All RCP sections shall be joined in such a manner that the ends are fully entered and the inner surfaces are reasonable. Average joint gap that exceeds 1/8 inch shall be filled with an approved flexible plastic sealant.
- Joint restraints and toe-walls, conforming to CDOT M&S Standard Plan No. M-601-11 shall be used on all RCP flared end section outfalls.
- Epoxy coated rebar shall be used as reinforcing steel on all storm inlets and structures. Reference CDOT M&S Standard Plan No. M-604-10, 11, 12, and 13.
- CDOT Class D concrete shall be used for all concrete drainage structures.
- Pre-cast inlets and manhole bases shall not be used within the Town of Parker Right-of-way, with the exception of CDOT Type C and D inlets.
- Two- (2) manhole access points are required on all Type "R" curb inlets greater than or equal to ten (10) feet in length as presented in CDOT M&S Standard Plan No. M-604-12.
- All grouting (boulders, riprap) shall be in accordance with the Revision of Section 506 of the CDOT Standard Specifications as presented in the SDECM.
- All boulders and riprap shall be selected and placed in accordance with the Revision of Section 506 of the CDOT Standard Specifications as presented in the SDECM.
- Contractor shall refer to the Town of Parker's Construction Best Management Practices details and notes for all requirements relating to re-vegetation, sediment and erosion control requirements for construction activities.
- Pipe bells shall not be cast into manhole bases or inlets.

# A.L.T.A./N.S.P.S. LAND TITLE SURVEY

A PORTION OF THE SE 1/4 OF SECTION 20, TOWNSHIP 6 SOUTH,  
RANGE 66 WEST OF THE 6TH P.M. COUNTY OF  
DOUGLAS, STATE OF COLORADO

**SCHEDULE B—SECTION 2 TITLE EXCEPTION COMMENTS:**

10. ANY TAXES OR ASSESSMENTS BY REASON OF THE INCLUSION OF THE LAND IN THE PARKER WATER AND SANITATION DISTRICT, AS EVIDENCED BY INSTRUMENT RECORDED JANUARY 25, 1988 IN BOOK 772 AT PAGE 607. (NOT PLOTTABLE)
11. THE EFFECT OF ANNEXATION MAP RECORDED FEBRUARY 5, 1988 AT RECEPTION NO. 880288B. (NOT PLOTTABLE)
12. TERMS, CONDITIONS, PROVISIONS, AGREEMENTS AND OBLIGATIONS CONTAINED IN THE REAL PROPERTY INCLUSION AGREEMENT AS SET FORTH BELOW: RECORDING DATE: FEBRUARY 8, 1988 RECORDING NO.: BOOK 775 AT PAGE 264 (NOT PLOTTABLE)
13. TERMS, CONDITIONS, PROVISIONS, AGREEMENTS AND OBLIGATIONS CONTAINED IN THE ANNEXATION ORDINANCE #252 AS SET FORTH BELOW: RECORDING DATE: MARCH 16, 1988 RECORDING NO.: BOOK 781 AT PAGE 611 (NOT PLOTTABLE)
14. TERMS, CONDITIONS, PROVISIONS, AGREEMENTS AND OBLIGATIONS CONTAINED IN THE PARKER RIDGE PRELIMINARY DEVELOPMENT PLAN AS SET FORTH BELOW: RECORDING DATE: MARCH 16, 1988 RECORDING NO.: RECEPTION NO. 8806041 (NOT PLOTTABLE)
15. ANY TAXES OR ASSESSMENTS BY REASON OF THE INCLUSION OF THE LAND IN THE CHERRY CREEK BASIN AUTHORITY, AS EVIDENCED BY INSTRUMENT RECORDED MAY 6, 1988 IN BOOK 790 AT PAGE 718. (NOT PLOTTABLE)
16. ALL NONTRIBUTARY AND NOT NONTRIBUTARY GROUNDWATER IN THE LOWER DAWSON, DENVER, ARAPAHOE AND LARAMIE- FOX HILLS AQUIFERS UNDERLYING THE PROPERTY TOGETHER WITH THE RIGHT TO WITHDRAW AND USE THE SAME AS CONVEYED TO PARKER WATER AND SANITATION DISTRICT BY DEED RECORDED MAY 27, 1988 IN BOOK 794 AT PAGE 478. (NOT PLOTTABLE)
17. TERMS, CONDITIONS, PROVISIONS, AGREEMENTS AND OBLIGATIONS CONTAINED IN THE BRADBURY RANCH DEVELOPMENT GUIDE AS SET FORTH BELOW: RECORDING DATE: NOVEMBER 9, 1994 RECORDING NO.: BOOK 1229 AT PAGE 1814 (NOT PLOTTABLE)
18. TERMS, CONDITIONS, PROVISIONS, AGREEMENTS, EASEMENTS AND OBLIGATIONS CONTAINED IN THE STANDARD AVIGATION AND HAZARD EASEMENT AS SET FORTH BELOW: RECORDING DATE: AUGUST 29, 1995 RECORDING NO.: BOOK 1284 AT PAGE 1575 (NOT PLOTTABLE)
19. COVENANTS, CONDITIONS AND RESTRICTIONS, WHICH DO NOT INCLUDE A FORFEITURE OR REVERTER CLAUSE, BUT OMITTING ANY COVENANTS OR RESTRICTIONS, IF ANY, INCLUDING BUT NOT LIMITED TO THOSE BASED UPON RACE, COLOR, RELIGION, SEX, SEXUAL ORIENTATION, FAMILIAL STATUS, MARITAL STATUS, DISABILITY, HANDICAP, NATIONAL ORIGIN, ANCESTRY, SOURCE OF INCOME, GENDER, GENDER IDENTITY, GENDER EXPRESSION, MEDICAL CONDITION OR GENETIC INFORMATION, AS SET FORTH IN APPLICABLE STATE OR FEDERAL LAWS, EXCEPT TO THE EXTENT THAT SAID COVENANT OR RESTRICTION IS PERMITTED BY APPLICABLE LAW, AS SET FORTH IN THE DOCUMENT RECORDING DATE: MAY 3, 1996 RECORDING NO: BOOK 1338 AT PAGE 800 CERTIFICATE HOMEOWNERS DECLARATION FOR BRADBURY RANCH: RECORDING DATE: AUGUST 15, 1996 RECORDING NO.: BOOK 1363 AT PAGE 1746 (NOT PLOTTABLE)
20. TERMS, CONDITIONS, PROVISIONS, AGREEMENTS AND OBLIGATIONS CONTAINED IN THE AGREEMENT REGARDING TRAFFIC SIGNAL AS SET FORTH BELOW: RECORDING DATE: SEPTEMBER 17, 1996 RECORDING NO.: BOOK 1370 AT PAGE 1654 (NOT PLOTTABLE)
21. TERMS, CONDITIONS, PROVISIONS, AGREEMENTS AND OBLIGATIONS CONTAINED IN THE COVENANT AND SERVIDUTE BRADBURY RANCH AS SET FORTH BELOW: RECORDING DATE: NOVEMBER 8, 1999 RECORDING NO.: BOOK 1775 AT PAGE 441 (NOT PLOTTABLE)
22. TERMS, CONDITIONS, PROVISIONS, AGREEMENTS AND OBLIGATIONS CONTAINED IN THE BRADBURY RANCH DEVELOPMENT PLAN 3RD AMENDMENT AS SET FORTH BELOW: RECORDING DATE: AUGUST 23, 2000 RECORDING NO.: RECEPTION NO. 59142 (NOT PLOTTABLE)

**GENERAL NOTES:**

1. NOTICE: ACCORDING TO COLORADO LAW YOU MUST COMMENCE ANY LEGAL ACTION BASED UPON ANY DEFECT IN THIS SURVEY WITHIN THREE YEARS AFTER YOU FIRST DISCOVER SUCH DEFECT. IN NO EVENT MAY ANY LEGAL ACTION BASED UPON ANY DEFECT IN THIS SURVEY BE COMMENCED MORE THAN TEN YEARS FROM THE DATE OF THE CERTIFICATE SHOWN HEREON.
2. THIS A.L.T.A./N.S.P.S. LAND TITLE SURVEY, AND THE INFORMATION HEREON, MAY NOT BE USED FOR ANY ADDITIONAL OR EXTENDED PURPOSES BEYOND THAT FOR WHICH IT WAS INTENDED AND MAY NOT BE USED BY ANY PARTIES OTHER THAN THOSE TO WHICH IT IS CERTIFIED.
3. THIS SURVEY DOES NOT CONSTITUTE A TITLE SEARCH BY RUBINO SURVEYING TO DETERMINE OWNERSHIP OR EASEMENTS OF RECORD, RIGHT OF WAY OR TITLE OF RECORD. RUBINO SURVEYING RELIED UPON FIDELITY NATIONAL TITLE, COMMITMENT NO. 100-N0027606-010-T02, EFFECTIVE MAY 27, 2020, THE PROPERTY SHOWN AND DESCRIBED HEREON IS ALL OF THE PROPERTY DESCRIBED IN SAID TITLE COMMITMENT.
4. THE BEARINGS ARE BASED ON THE NORTH LINE OF THE SOUTHEAST 1/4 OF SECTION 20 ASSUMED TO BEAR N89°25'39"E BETWEEN MONUMENTS FOUND AND DESCRIBED HEREON.
5. SUBSURFACE BUILDINGS, IMPROVEMENTS OR STRUCTURES ARE NOT NECESSARILY SHOWN HEREON.
6. THIS SURVEY IS VALID ONLY IF PRINT HAS SEAL AND SIGNATURE OF SURVEYOR.
7. ONLY SURFACE EVIDENCE OF UTILITIES VISIBLE AT THE TIME OF THE FIELDWORK ARE SHOWN HEREON. ALL UNDERGROUND UTILITIES MUST BE FIELD LOCATED BY THE APPROPRIATE AGENCY OR UTILITY COMPANY PRIOR TO ANY EXCAVATION, PURSUANT TO C.R.S. SEC. 9-1.5-103.
8. THE DISTANCE MEASUREMENTS SHOWN HEREON ARE THE U.S. SURVEY FOOT.

**SURVEYOR'S CERTIFICATE:**

TO:  
CIRCLE K STORES, INC.;  
FIDELITY NATIONAL TITLE;  
THIS IS TO CERTIFY THAT THIS MAP OR PLAT AND THE SURVEY ON WHICH IT IS BASED WERE MADE IN ACCORDANCE WITH 2016 MINIMUM STANDARD DETAIL REQUIREMENTS FOR ALTA/NSPS LAND TITLE SURVEYS, JOINTLY ESTABLISHED AND ADOPTED BY ALTA AND NSPS, AND INCLUDES ITEMS 1, 2, 4, 6(a), 7(a) 8, 9 AND 11 OF TABLE A THEREOF. THE FIELD WORK WAS COMPLETED ON 6/04/20.

PURSUANT TO COLORADO STATE BOARD OF LICENSURE FOR PROFESSIONAL LAND SURVEYORS RULE 6.2.2 THE UNDERSIGNED FURTHER CERTIFIES THAT THIS MAP OR PLAT WAS PREPARED BY ME OR UNDER MY RESPONSIBLE CHARGE, IS ACCURATE TO THE BEST OF MY KNOWLEDGE, INFORMATION AND BELIEF, IS IN ACCORDANCE WITH APPLICABLE STANDARDS OF PRACTICE AND IS NOT A GUARANTY OR WARRANTY, EITHER EXPRESSED OR IMPLIED.

- LEGEND**
- ⊠ ELECTRIC TRANSFORMER
  - ⊞ UTILITY VAULT
  - ⊞ UTILITY VAULT
  - ⊞ FIRE HYDRANT
  - ⊞ SANITARY SEWER MANHOLE
  - ⊞ STORM SEWER MANHOLE
  - ⊞ LIGHT POLE
  - ⊞ UTILITY VAULT
  - ⊞ WATER VALVE
  - COM— UNDERGROUND COMMUNICATION LINES
  - ELE— UNDERGROUND ELECTRIC LINES
  - GAS— UNDERGROUND GAS LINES
  - SAN— UNDERGROUND SANITARY SEWER LINES
  - SSW— UNDERGROUND STORM SEWER LINES
  - WAT— UNDERGROUND WATER LINES
  - (A) SET PIN/CAP PLS 14142

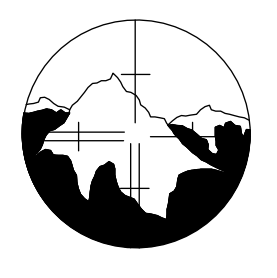
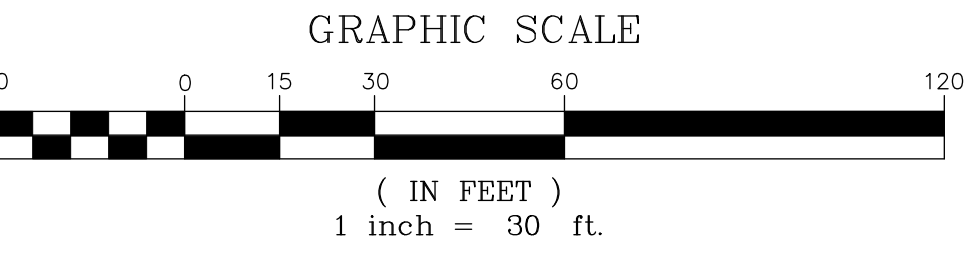

prepared by:  
RUBINO SURVEYING  
3312 AIRPORT ROAD  
BOULDER, COLORADO 80301  
(303) 464-9515

REVISIONS	
DRAWING NO: 20144ALTA.DWG	SHEET 1 OF 1
DATE OF SURVEY: 6/02/20	DATE OF DRAWING: 6/08/20
DRAWN BY: BR	PROJECT NO: 20144

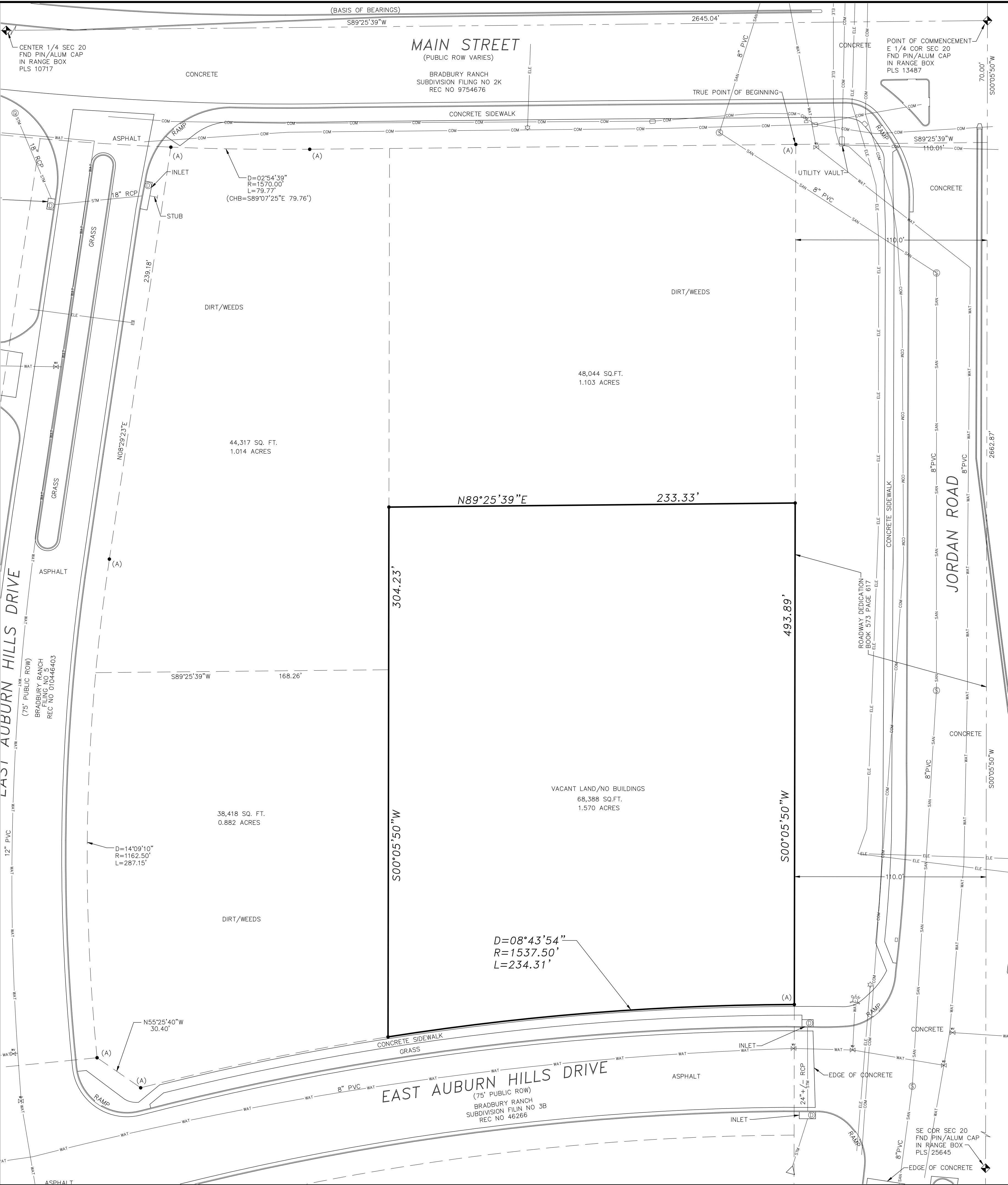



Know what's below.  
Call before you dig.



2435 RESEARCH PARKWAY, SUITE 300  
COLORADO SPRINGS, CO 80920  
PHONE: (719) 575-0100  
FAX: (719) 575-0208



LAND DEVELOPMENT  
CONSULTANTS, LLC

950 S. CHERRY STREET, SUITE 512  
DENVER, CO 80246

OWNER/DEVELOPER:



ROCKY MOUNTAINS DIVISION  
5500 S QUEBEC STREET, SUITE 100  
GREENWOOD VILLAGE, CO 80111

SEAL

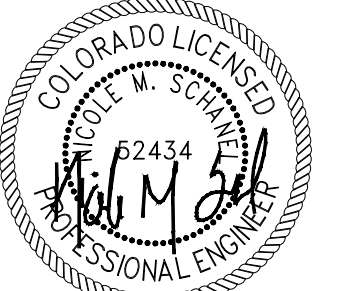

FOR AND ON BEHALF OF MATRIX DESIGN GROUP, INC  
CONTRACTOR IS RESPONSIBLE FOR OBTAINING THE  
MOST RECENT PROJECT CONSTRUCTION DOCUMENTS.  
MATRIX DESIGN GROUP IS NOT RESPONSIBLE FOR  
CHANGES, ALTERATIONS, OR USE OF CONSTRUCTION  
DOCUMENTS PRIOR TO JURISDICTIONAL APPROVAL.

VICINITY MAP: SCALE: NTS

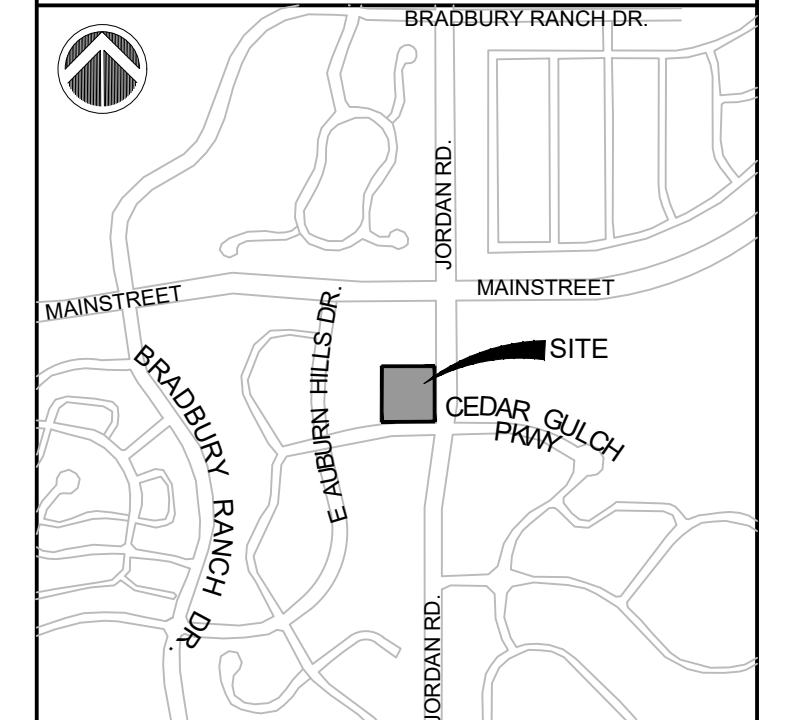

PROJECT:

CIRCLE K

CONSTRUCTION DOCUMENTS

16846 E AUBURN HILLS DRIVE  
PARKER, CO 80134

REVISION HISTORY:

NO.	DATE	DESCRIPTION	BY

DRAWING INFORMATION:

PROJECT NO: 21.1207.030

DRAWN BY: RPD

CHECKED BY: NMS

DESIGNED BY: NMS

SHEET TITLE:

SITE PLAN

C1.0

SHEET 4 OF 26

DATE: NOVEMBER 2022

### SITE NOTES

- 01 LANDSCAPE AREA (PER LANDSCAPE PLANS)
- 02 TRANSFORMER PAD (PER ELEC CO AND / OR ARCH PLANS)
- 03 TRASH ENCLOSURE (PER ARCH PLANS)
- 04 FUEL CANOPY 192' x 24' SG-7 (TYP PER ARCH PLANS)
- 05 FUEL PUMPS (PER ARCH PLANS)
- 06 PROPERTY MONUMENT SIGN (BY OTHERS)
- 07 PROPOSED SIGN (PER ARCH PLANS)
- 08 UNDERGROUND FUEL TANKS (PER ARCH PLANS)
- 09 AIR UNIT (PER ARCH PLANS)
- 10 VAN ACCESSIBLE PARKING STALL, ISA SYMBOL AND SIGNAGE (PER ARCH PLANS)
- 11 PIPE BOLLARDS (6' O.C., PER ARCH PLANS)
- 12 CONVENIENCE STORE (5,200 SF)(SEE ARCHITECTURAL PLANS)
- 13 PROPOSED LIGHT POLE (PER ARCH PLANS)
- 14 BIKE RACK WITH 2 SPACES (PER ARCH PLANS)
- 15 CO2 ENCLOSURE (PER ARCH PLANS)
- 16 DIRECTIONAL ARROW PAVEMENT MARKING (SEE SITE PLAN DETAILS)
- 17 2' CONCRETE GUTTER PAN (SEE SITE PLAN DETAILS)
- 18 TABLES
- 19 VENT PIPES (PER ARCH PLANS)
- 20 STOP BAR PAVEMENT MARKING (SEE SITE PLAN DETAILS)
- 21 STOP SIGN (SEE SITE PLAN DETAILS)
- 22 DECORATIVE KNEE WALL (2.5'-3' HEIGHT)
- 23 PROPOSED FIRE HYDRANT W/ VALVE

### LEGEND

- PROPERTY LINE
- ==== CATCH CONCRETE CURB & GUTTER
- ==== SPILL CONCRETE CURB & GUTTER
- EXISTING CURB & GUTTER
- ◇ # PARKING COUNT

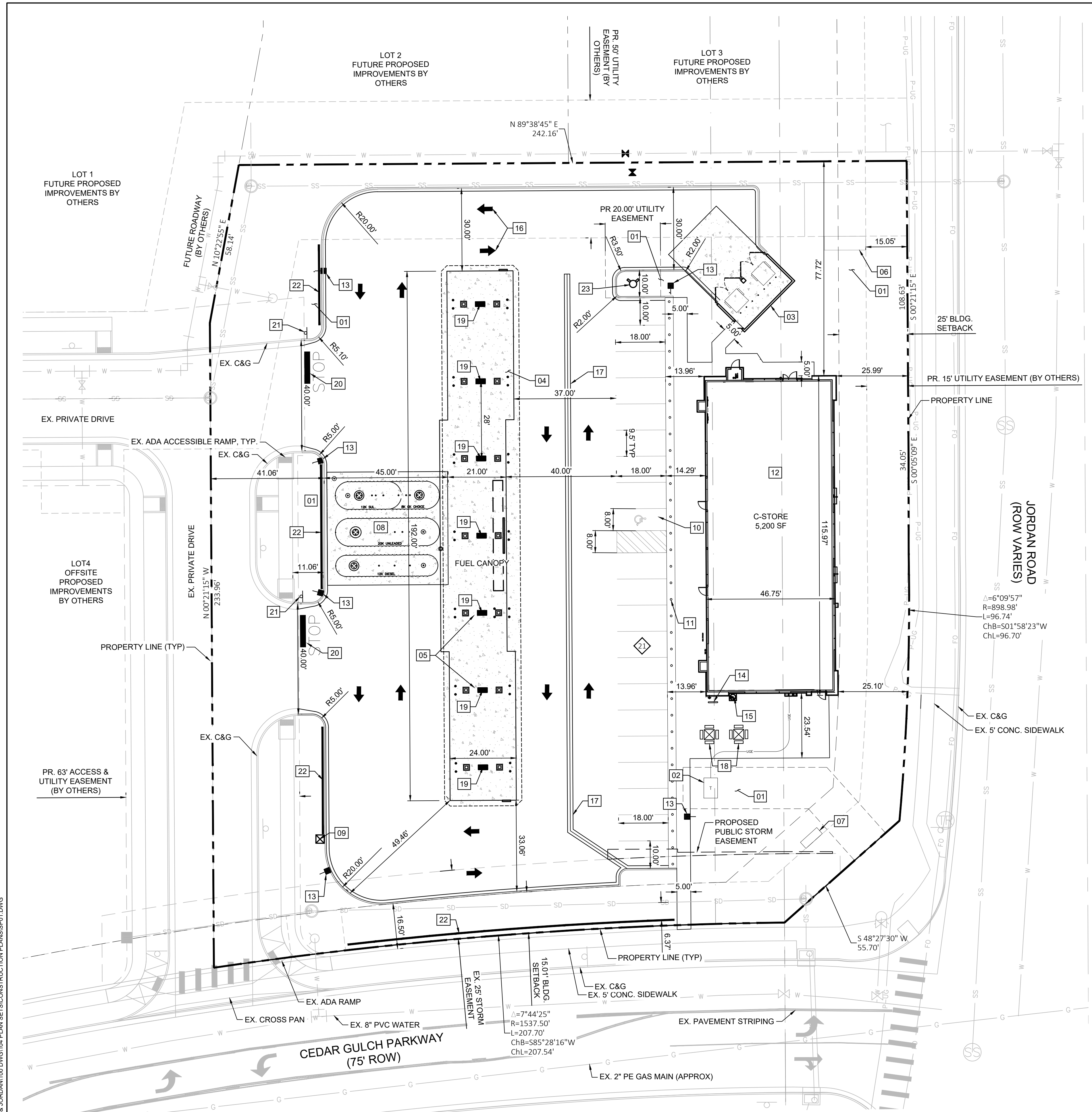
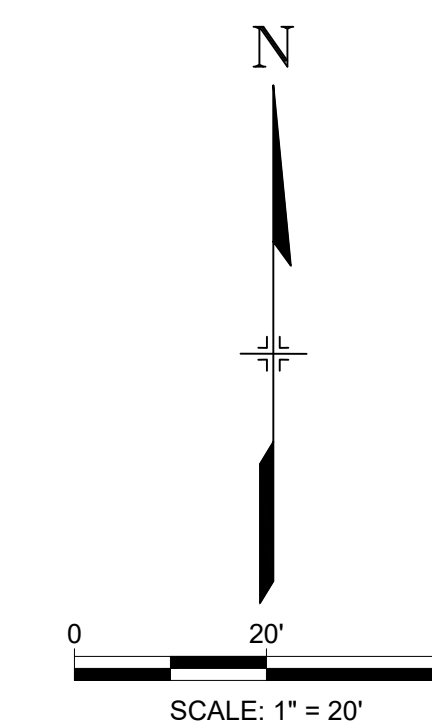

### NOTES

- ALL DIMENSIONS ARE TO FLOWLINE OF CURB UNLESS OTHERWISE NOTED.
- ALL IMPROVEMENTS SHALL BE PERFORMED IN A SINGLE PHASE OF CONSTRUCTION.
- SIGNAGE SHALL BE INSTALLED ACCORDING TO 2015 IFC SECTION 2204.3.5 AND 2205.6.
- EMERGENCY PHONE SHALL PROVIDE DIRECT LINE TO FIRE DEPARTMENT. TELEPHONE NO. SHALL BE 911.
- PARCEL BOUNDARY LINES ARE BASED ON ALTA LAND TITLE SURVEY PROVIDED BY RUBINO SURVEYING ON JUNE 08, 2020

NOTE: THE LOCATIONS OF EXISTING ABOVE GROUND AND UNDERGROUND UTILITIES ARE SHOWN IN AN APPROXIMATE WAY ONLY. THE CONTRACTOR SHALL DETERMINE THE EXACT LOCATION OF ALL EXISTING UTILITIES BEFORE COMMENCING WORK. THE CONTRACTOR SHALL BE FULLY RESPONSIBLE FOR ANY AND ALL DAMAGES WHICH MIGHT BE CAUSED BY THEIR FAILURE TO EXACTLY LOCATE AND PRESERVE ANY AND ALL ABOVE GROUND AND UNDERGROUND UTILITIES.

NOTE: CONTRACTOR MUST COORDINATE WORK WITH UTILITY COMPANY AND CITY PRIOR TO BEGINNING WORK AND IS RESPONSIBLE FOR ALL MATERIALS, LABOR, REPAIRS, ETC. TO COMPLETE WORK AND RESTORE AREA TO SAME STATE PRIOR TO STARTING WORK

The Town of Parker review constitutes general compliance with the Town's Standards and approved variances, subject to these plans being stamped, signed, and dated by the professional engineer of record. Review by the Town does not constitute approval of the plan design or accuracy and correctness of engineering calculations. Errors in the design or calculations remain the responsibility of the registered professional engineer whose stamp and signature are affixed to this document.

This review does not constitute approval of any private on-site improvements which may be shown. Construction cannot commence until all required drainage/traffic report(s), final development plan(s), special review(s), grading permit, and/or other permits are complete, approved and on file with the Town of Parker.

Town of Parker, Director of Engineering Date

FILE LOCATION: \\CIRCLE K\MAN & JORDAN\100 DIVISION\4 PLAN SETS\CONSTRUCTION PLANS\SP01.DWG

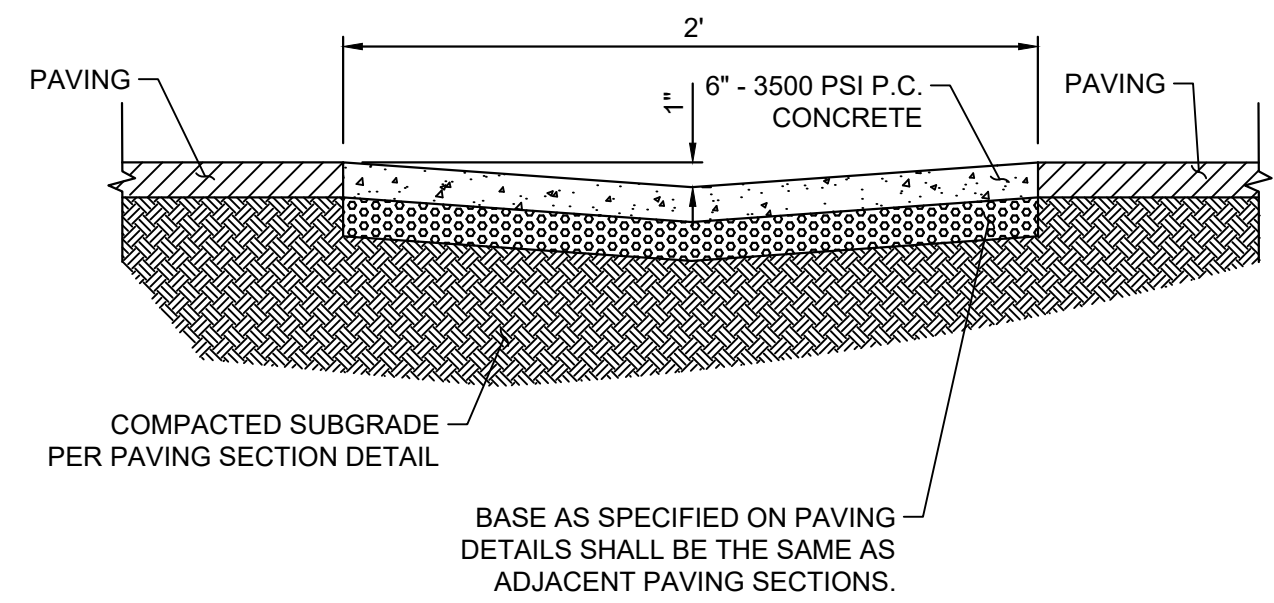
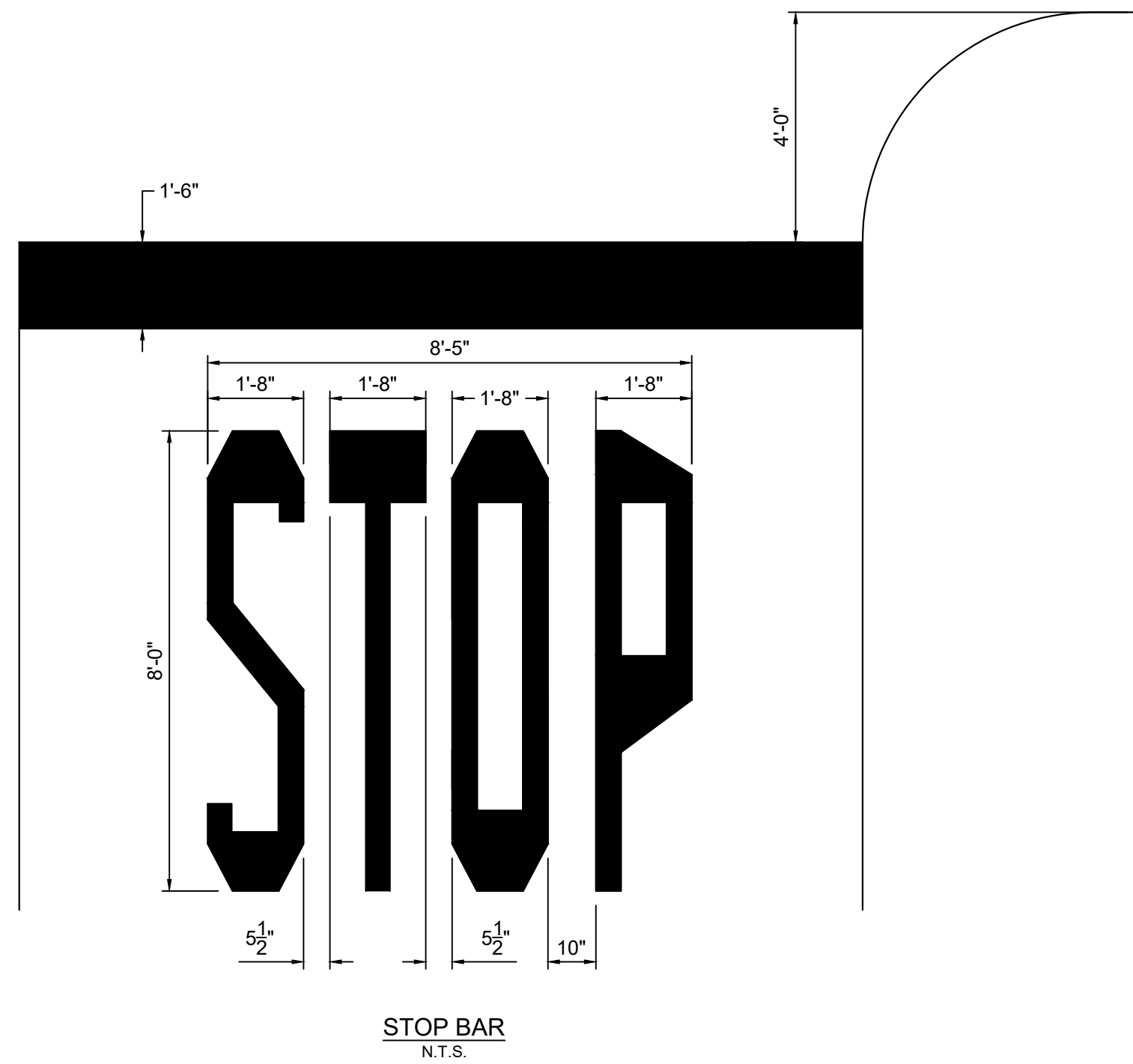

- NOTES:
1. COMPRESSIVE STRENGTH: 3,500 P.S.I. MINIMUM AT 28 DAYS.
  2. REINFORCEMENT: WELDED WIRE FABRIC - 6"X6" - W 2.1 X W 2.1, 2" FROM BOTTOM
  3. WEAKENED - PLANE CONTROL JOINTS TO BE 15' O.C. AND FILLED/SEALED. SEE SPECIFICATIONS FOR APPROVED FILLER/SEALERS.

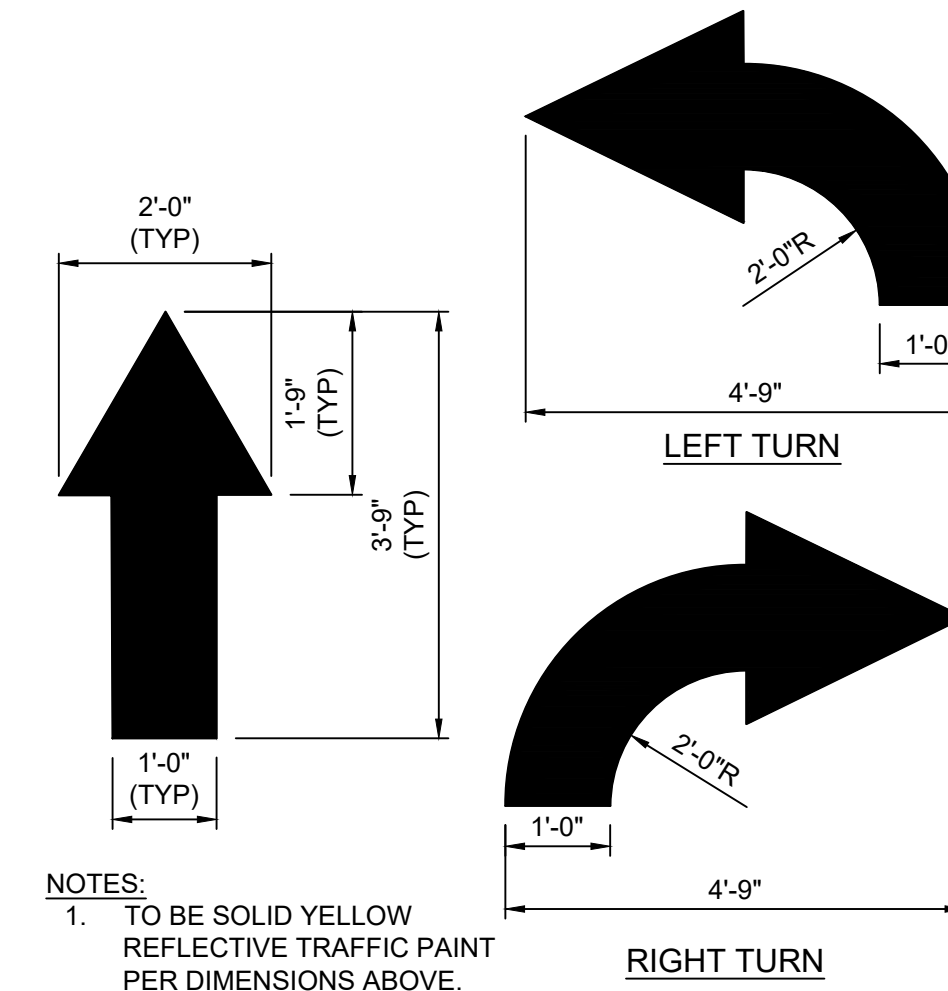

- NOTES:
1. TO BE SOLID YELLOW REFLECTIVE TRAFFIC PAINT PER DIMENSIONS ABOVE.

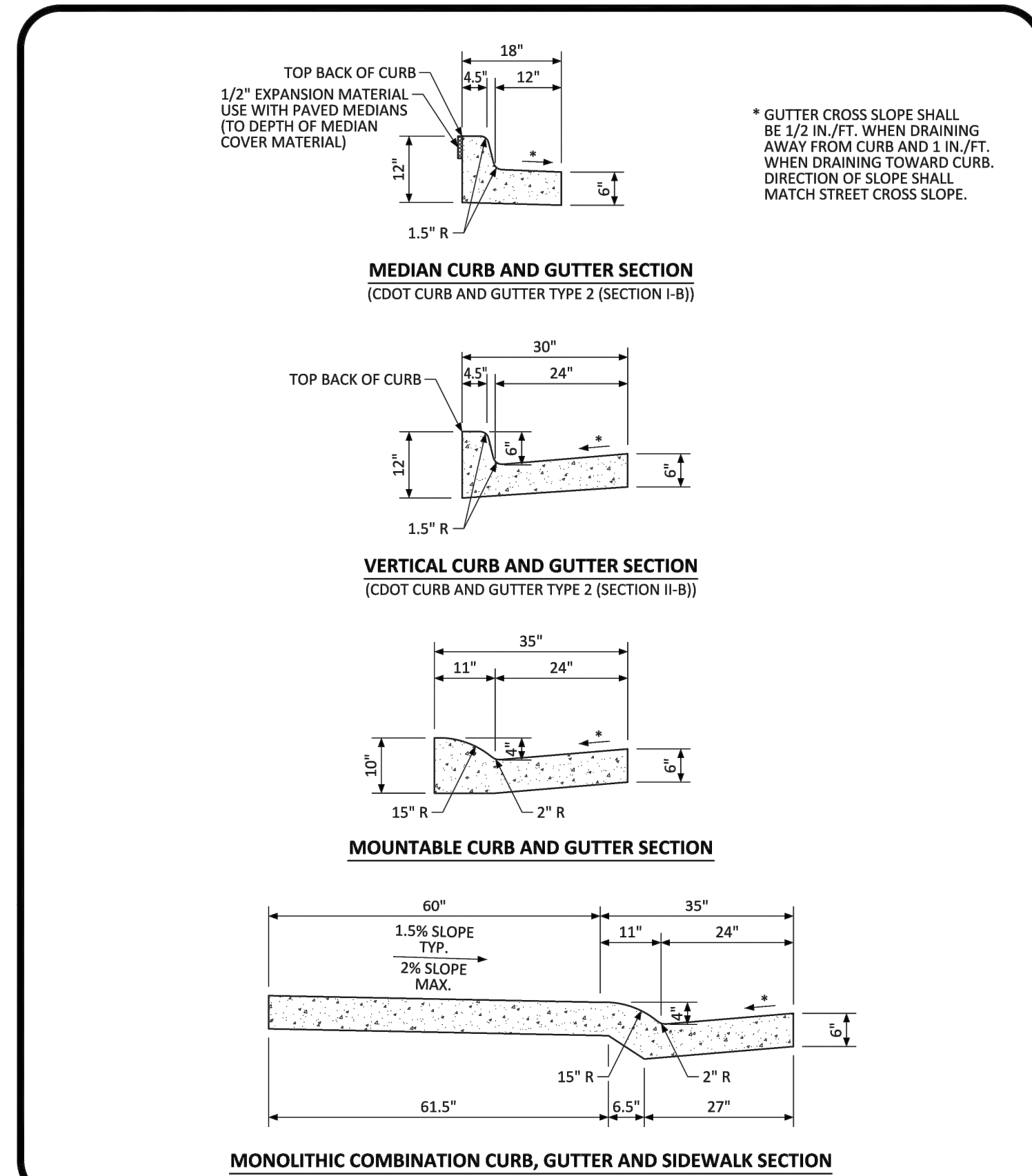

NO CHANGES ARE TO BE MADE TO THIS DRAWING WITHOUT WRITTEN PERMISSION OF THE TOWN OF PARKER.

**PARKER COLORADO**

**CURB, GUTTER, AND SIDEWALK SECTIONS STANDARD DETAIL**

DATE: NOVEMBER 2020

DETAIL: **3**

1 OF 1

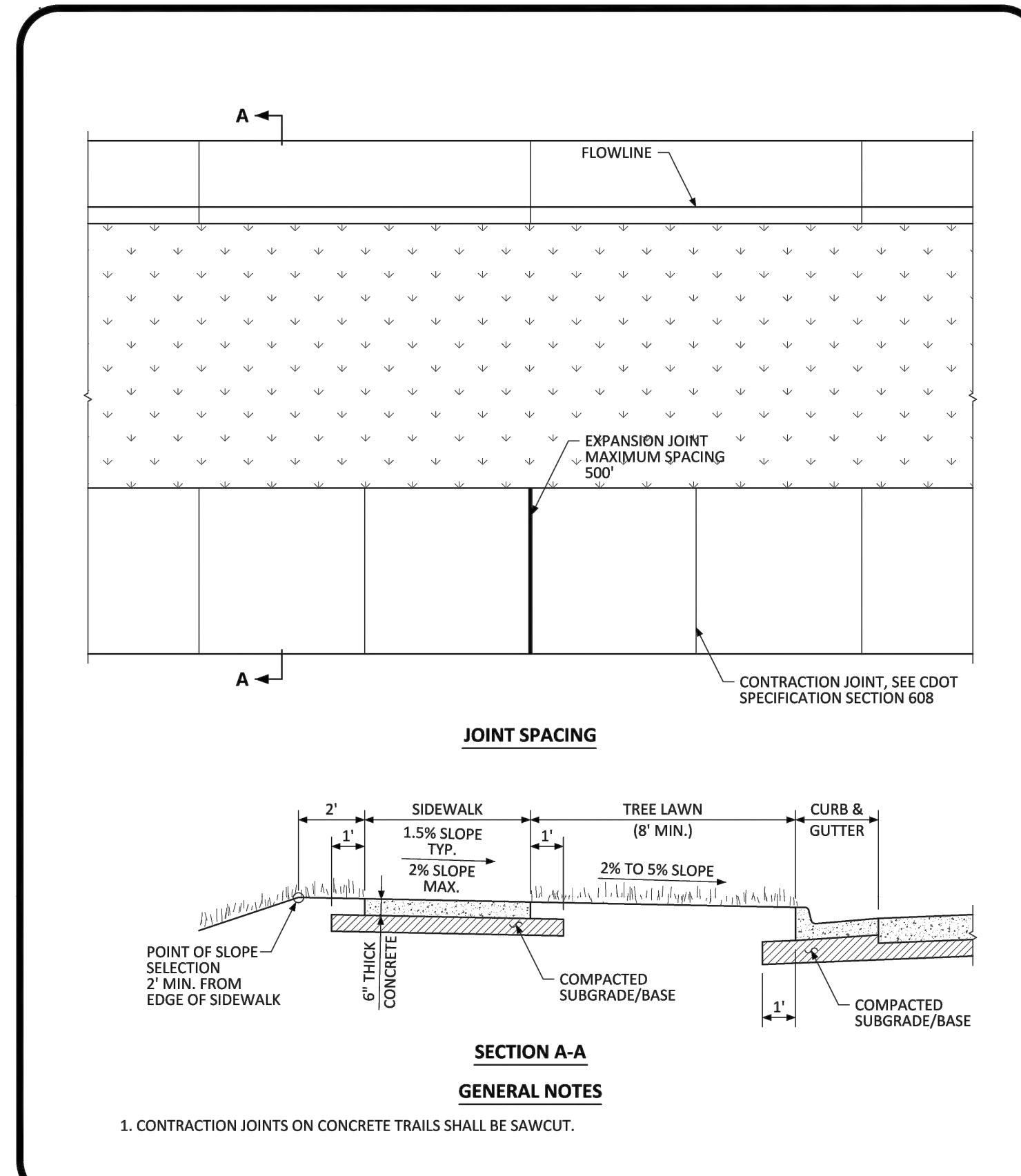

NO CHANGES ARE TO BE MADE TO THIS DRAWING WITHOUT WRITTEN PERMISSION OF THE TOWN OF PARKER.

**PARKER COLORADO**

**DETACHED SIDEWALK STANDARD DETAIL**

DATE: NOVEMBER 2020

DETAIL: **4**

1 OF 2

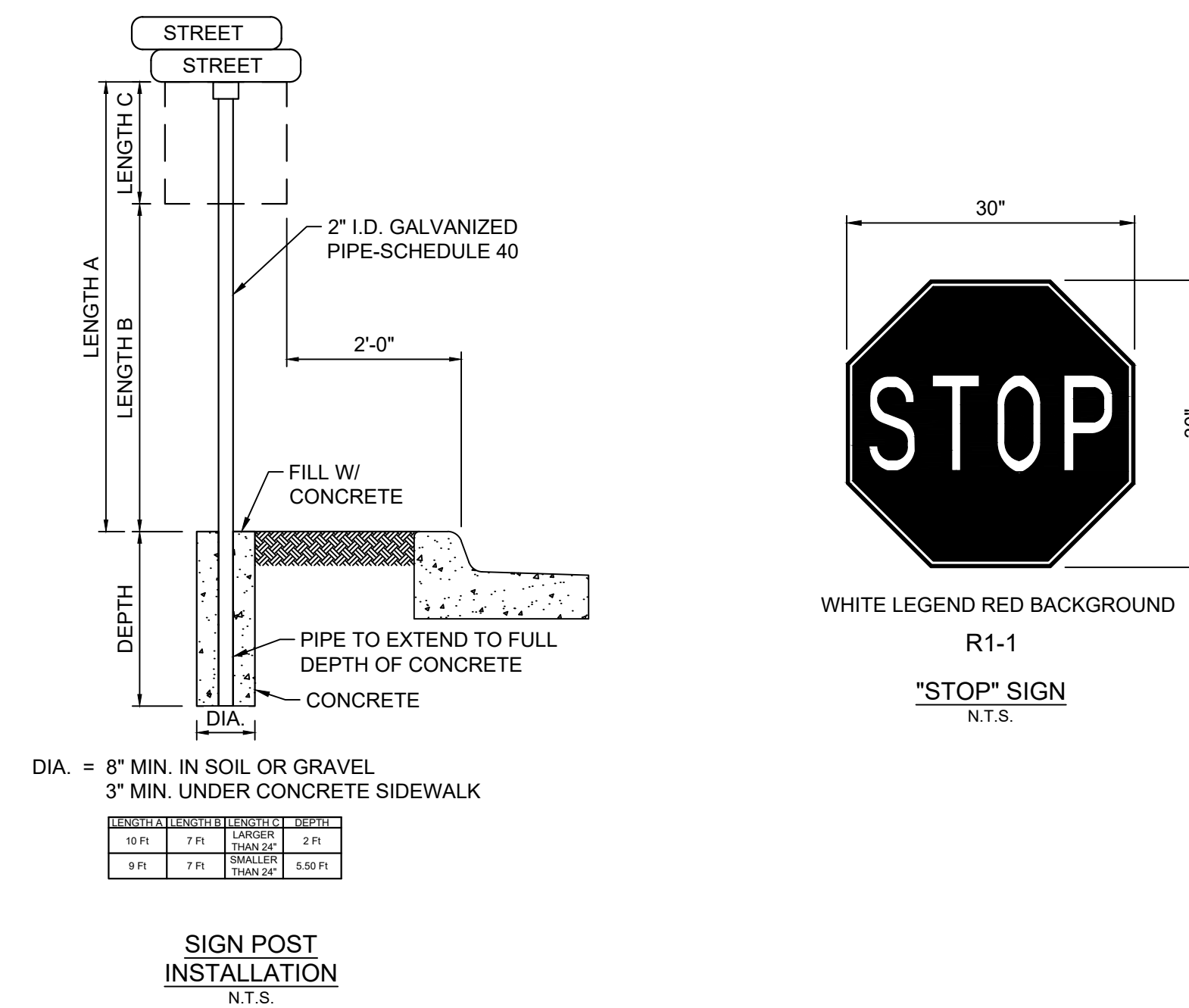

REVISION	DATE	BY	DESCRIPTION
1			

The Town of Parker review constitutes general compliance with the Town's Standards and approved variances, subject to these plans being stamped, signed, and dated by the professional engineer of record. Review by the Town does not constitute approval of the plan design or accuracy and correctness of engineering calculations. Errors in the design or calculations remain the responsibility of the registered professional engineer whose stamp and signature are affixed to this document.

This review does not constitute approval of any private on-site improvements which may be shown. Construction cannot commence until all required drainage/traffic report(s), final development plan(s), special review(s), grading permit, and/or other permits are complete, approved and on file with the Town of Parker.

Town of Parker, Director of Engineering \_\_\_\_\_ Date \_\_\_\_\_



CONSULTANTS:

**Matrix**  
2435 RESEARCH PARKWAY, SUITE 300  
COLORADO SPRINGS, CO 80920  
PHONE: (719) 575-0100  
FAX: (719) 575-0208

**LAND DEVELOPMENT CONSULTANTS, LLC**  
950 S. CHERRY STREET, SUITE 512  
DENVER, CO 80246

OWNER/DEVELOPER:

**CIRCLE K**

ROCKY MOUNTAINS DIVISION  
5500 S QUEBEC STREET, SUITE 100  
GREENWOOD VILLAGE, CO 80111

SEAL

FOR AND ON BEHALF OF MATRIX DESIGN GROUP, INC. CONTRACTOR IS RESPONSIBLE FOR OBTAINING THE MOST RECENT PROJECT CONSTRUCTION DOCUMENTS. MATRIX DESIGN GROUP IS NOT RESPONSIBLE FOR CHANGES, ALTERATIONS, OR USE OF CONSTRUCTION DOCUMENTS PRIOR TO JURISDICTIONAL APPROVAL.

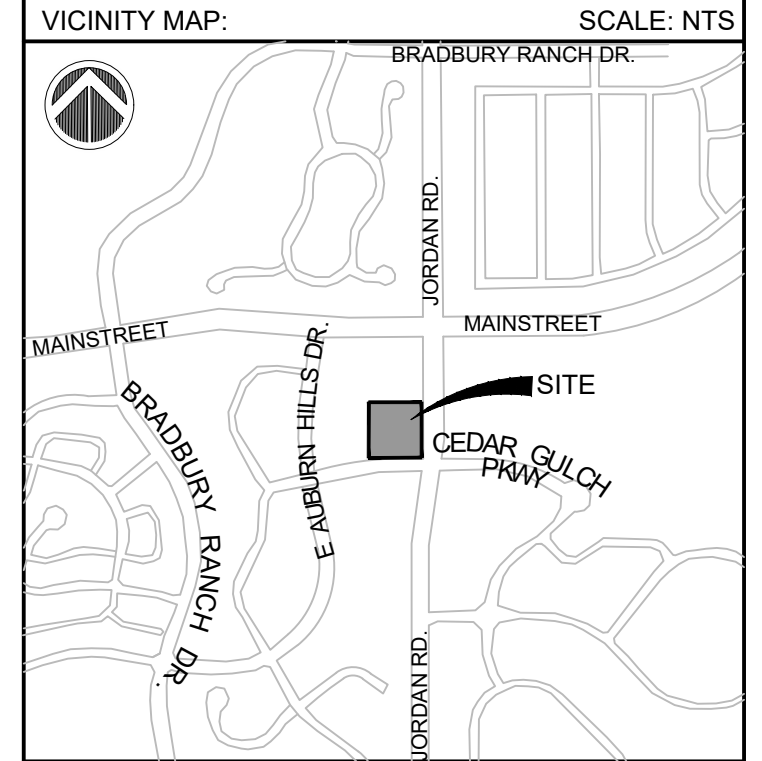

PROJECT:

**CIRCLE K**

**CONSTRUCTION DOCUMENTS**

16846 E AUBURN HILLS DRIVE  
PARKER, CO 80134

REVISION HISTORY:

NO.	DATE	DESCRIPTION	BY

DRAWING INFORMATION:

PROJECT NO: 21.1207.030

DRAWN BY: RAD

CHECKED BY: NMS

DESIGNED BY: NMS

SHEET TITLE:

**SITE PLAN DETAILS**

**C1.1**

**SHEET 5 OF 26**

DATE: NOVEMBER 2022

FILE LOCATION: S:\CIRCLE K\MARK & JORDAN\100 DIVISION\14 PLAN SETS\CONSTRUCTION PLANS\SP01.DWG



**Matrix**  
 2435 RESEARCH PARKWAY, SUITE 300  
 COLORADO SPRINGS, CO 80920  
 PHONE: (719) 575-0100  
 FAX: (719) 575-0208

**LAND DEVELOPMENT**  
 CONSULTANTS, LLC  
 950 S. CHERRY STREET, SUITE 512  
 DENVER, CO 80246  
 OWNER/DEVELOPER:

**CIRCLE K**

ROCKY MOUNTAINS DIVISION  
 5500 S QUEBEC STREET, SUITE 100  
 GREENWOOD VILLAGE, CO 80111

SEAL

FOR AND ON BEHALF OF MATRIX DESIGN GROUP, INC  
 CONTRACTOR IS RESPONSIBLE FOR OBTAINING THE  
 MOST RECENT PROJECT CONSTRUCTION DOCUMENTS.  
 MATRIX DESIGN GROUP IS NOT RESPONSIBLE FOR  
 CHANGES, ALTERATIONS, OR USE OF CONSTRUCTION  
 DOCUMENTS PRIOR TO JURISDICTIONAL APPROVAL.

VICINITY MAP: SCALE: NTS

PROJECT:  
**CIRCLE K**  
**CONSTRUCTION DOCUMENTS**  
 16846 E AUBURN HILLS DRIVE  
 PARKER, CO 80134

REVISION HISTORY:

NO.	DATE	DESCRIPTION	BY

DRAWING INFORMATION:

PROJECT NO: 21.1207.030  
 DRAWN BY: RAD  
 CHECKED BY: NMS  
 DESIGNED BY: NMS

**GRADING PLAN**

**C2.0**

SHEET 6 OF 26

DATE: NOVEMBER 2022

**GRADING LEGEND**

- PROPERTY BOUNDARY LINE
- LIMITS OF DISTURBANCE
- SETBACK LINE
- EASEMENT BOUNDARY LINE
- PROPOSED CATCH CONCRETE CURB & GUTTER
- PROPOSED SPILL CONCRETE CURB & GUTTER
- PROPOSED CONTOURS
- EXISTING CONTOURS
- 1.8% SLOPE DIRECTION
- XX.XX PROPOSED SPOT ELEVATION:
- (XX.XX) EXISTING SPOT ELEVATION:
- FG = FINISHED GROUND
- FL = FLOWLINE
- TBC = TOP BACK OF CURB
- FEE = FINISHED FLOOR ELEVATION
- GB = GRADE BREAK
- HP = HIGH POINT
- LP = LOW POINT
- TOW = TOP OF WALL
- BOW = BOTTOM OF WALL

**GRADING NOTES**

- 01 TIE TO EXISTING. CONTRACTOR TO VERIFY EXISTING LOCATION & ELEVATION.
- 02 TAPER CURB FROM 6" TO 0" OVER 2'
- 03 CDOT TYPE 2 (SECTION I-B) "CATCH" CURB AND GUTTER (SEE SITE PLAN DETAILS)
- 04 CDOT TYPE 2 (SECTION I-B) "SPILL" CURB AND GUTTER (SEE SITE PLAN DETAILS)
- 05 ACCESSIBLE PARKING STALL. SLOPE TO BE 2% MAX IN ANY DIRECTION IN THIS AREA
- 06 CONCRETE DRAIN PAN (SEE SITE PLAN DETAILS)

**NOTES**

1. TBC TO BE 6" ABOVE FL UNLESS OTHERWISE NOTED.
2. ADD 5900 TO ALL SPOT GRADE ELEVATIONS
3. REQUIREMENTS SHOWN ON SITE PLAN SHALL GOVERN. DRAWINGS AND SPECIFICATIONS
4. SHOWING OTHERWISE NOTWITHSTANDING, CONTRACTOR TO POINT OUT ANY DISCREPANCIES TO THE OWNERS REPRESENTATIVE PRIOR TO BID. CONTRACTOR MUST OBTAIN ALL STATE AND CITY STORM WATER DISCHARGE AND EROSION CONTROL PERMITS PRIOR TO ANY DISTURBANCE AND/OR GRADING ACTIVITY.
5. FINAL GRADES ARE SUBJECT TO MINOR CHANGE BY COMPANY REPRESENTATIVE. NO GRADE CHANGES IN EXCESS OF 0.05' WITHOUT COMPANY APPROVAL.
6. ANY FILL MATERIAL REQUIRED TO BRING THE SITE TO GRADE SHALL BE CLEAN FILL DIRT APPROVED BY GEOTECHNICAL ENGINEER AND SHALL BE PLACED AND COMPACTED PER GEOTECHNICAL REPORT RECOMMENDATIONS.
7. SET PROPERTY CORNER PINS IN CONCRETE. IF PROPERTY CORNERS ARE DESTROYED BY CONTRACTOR, THE CONTRACTOR SHALL BEAR THE EXPENSE OF RELOCATION CORNERS BY A REGISTERED SURVEYOR.
8. THIS DESIGN IS BASED ON A SOIL AND FOUNDATION INVESTIGATION. A COPY OF THIS REPORT IS AVAILABLE FOR INSPECTION BY THE CONTRACTORS.
9. ALL SPOT GRADES ARE TO FLOWLINE UNLESS OTHERWISE NOTED.
10. GENERAL CONTRACTOR SHALL BE RESPONSIBLE FOR MINIMIZING DEPOSITION OF ONSITE SEDIMENTS ONTO SURROUNDING PUBLIC STREETS DURING CONSTRUCTION.
11. ALL LANDSCAPING AREAS SHALL BE GRADED TO WITHIN 0.10' WITH COMPANY APPROVED TOP SOIL TO A MINIMUM 6" DEPTH
12. GENERAL CONTRACTOR TO PROVIDE BARRICADE PROTECTION WITH FLASHING LIGHTS AROUND ALL FOOTINGS, EXCAVATIONS AND ALL OFFSITE WORK.
13. PROPOSED FLOWLINE ELEVATION DOES NOT TAKE INTO ACCOUNT GUTTER DEPRESSION AT INLET.
14. CONTRACTOR RESPONSIBLE FOR ALL WORK NECESSARY FOR FINAL ACCEPTANCE OF WORK FROM CITY, UTILITY DISTRICTS OR ANY OTHER GOVERNING AGENCY, INCLUDING BUT NOT LIMITED TO AS-BUILT DRAWINGS, INSPECTIONS, TESTING REPORTS AND CERTIFICATIONS.
15. ALL SIDEWALK CROSS SLOPES SHALL NOT EXCEED 2.00% AND ALL SIDEWALK RUNNING
16. PAVEMENT SLOPES SHALL NOT EXCEED 5.00%.

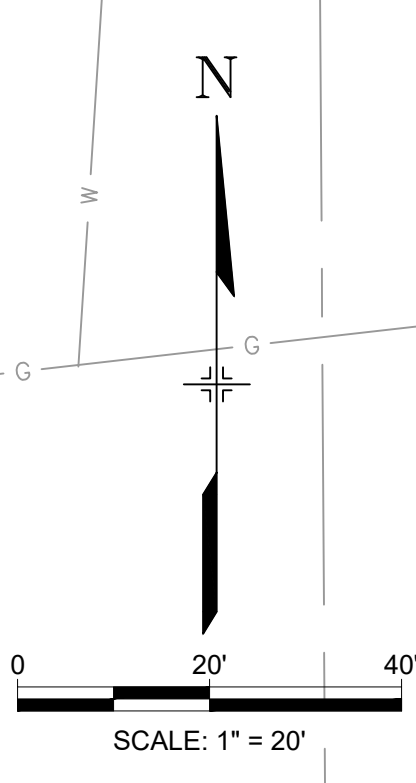
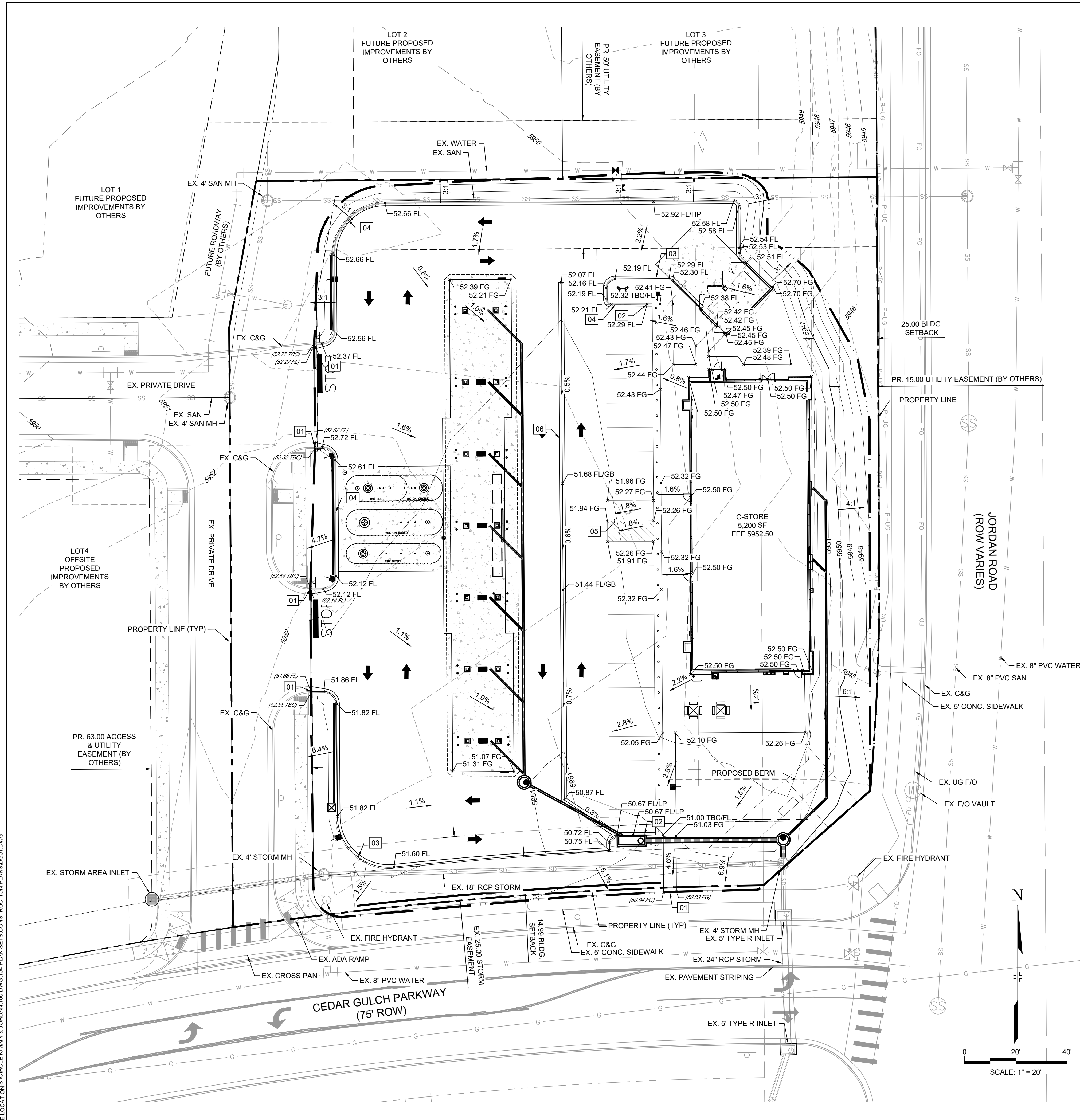

The Town of Parker review constitutes general compliance with the Town's Standards and approved variances, subject to these plans being stamped, signed, and dated by the professional engineer of record. Review by the Town does not constitute approval of the plan design or accuracy and correctness of engineering calculations. Errors in the design or calculations remain the responsibility of the registered professional engineer whose stamp and signature are affixed to this document.

This review does not constitute approval of any private on-site improvements which may be shown. Construction cannot commence until all required drainage/traffic report(s), final development plan(s), special review(s), grading permit, and/or other permits are complete, approved and on file with the Town of Parker.

Town of Parker, Director of Engineering Date

FILE LOCATION: S:\CIRCLE K\MIAMI & JORDAN\1100 DIVISION 14 PLAN SETS\CONSTRUCTION PLANS\01.DWG



Know what's below.  
Call before you dig.



2435 RESEARCH PARKWAY, SUITE 300  
COLORADO SPRINGS, CO 80920  
PHONE: (719) 575-0100  
FAX: (719) 575-0208



LAND DEVELOPMENT  
CONSULTANTS, LLC

950 S. CHERRY STREET, SUITE 512  
DENVER, CO 80246

OWNER/DEVELOPER:



ROCKY MOUNTAINS DIVISION  
5500 S QUEBEC STREET, SUITE 100  
GREENWOOD VILLAGE, CO 80111

SEAL

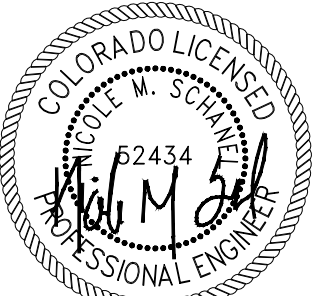

FOR AND ON BEHALF OF MATRIX DESIGN GROUP, INC  
CONTRACTOR IS RESPONSIBLE FOR OBTAINING THE  
MOST RECENT PROJECT CONSTRUCTION DOCUMENTS.  
MATRIX DESIGN GROUP IS NOT RESPONSIBLE FOR  
CHANGES, ALTERATIONS, OR USE OF CONSTRUCTION  
DOCUMENTS PRIOR TO JURISDICTIONAL APPROVAL.

VICINITY MAP: SCALE: NTS

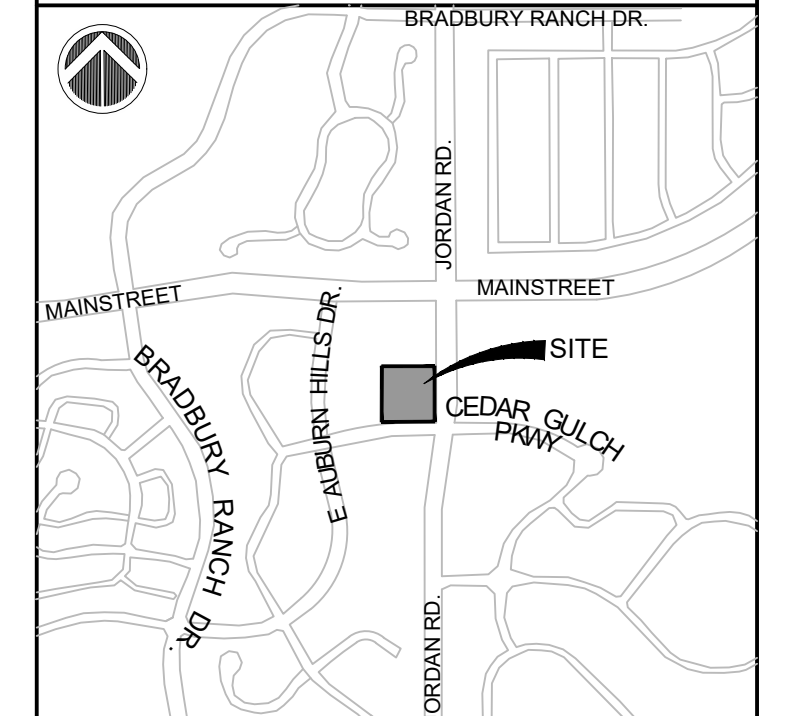

PROJECT:

**CIRCLE K**

**CONSTRUCTION DOCUMENTS**

16846 E AUBURN HILLS DRIVE  
PARKER, CO 80134

REVISION HISTORY:

NO.	DATE	DESCRIPTION	BY

DRAWING INFORMATION:

PROJECT NO: 21.1207.030

DRAWN BY: RAD

CHECKED BY: NMS

DESIGNED BY: NMS

SHEET TITLE:

**PAVEMENT PLAN**

**C3.0**

**SHEET 7 OF 26**

DATE: NOVEMBER 2022

### PAVING NOTES

- 01 MATCH EXISTING PAVEMENT ELEVATION
- 02 TAPER CURB TO MATCH EXISTING CURB
- 03 TAPER CURB FROM 6" TO 0" OVER 2'

### PAVING DETAILS

- 01 SPILL CONCRETE CURB & GUTTER (REF SHEET 5)
- 02 CATCH CONCRETE CURB & GUTTER (REF SHEET 5)
- 03 STANDARD DUTY ASPHALT PAVING (REF SHEET 8)
- 04 HEAVY DUTY CONCRETE PAVING (REF SHEET 8)
- 05 STANDARD DUTY CONCRETE PAVING (REF SHEET 8)
- 06 CONCRETE SIDEWALK (REF SHEET 5)
- 07 CONCRETE DRAIN PAN (REF SHEET 5)
- 08 CONCRETE JOINT DETAILS (REF SHEET 8)

### LEGEND

- PROPERTY LINE
- ==== CATCH CONCRETE CURB & GUTTER
- ==== SPILL CONCRETE CURB & GUTTER
- ==== EXISTING CURB & GUTTER
- ==== STANDARD DUTY ASPHALT (REF SHEET 8)
- ==== HEAVY DUTY CONCRETE (REF SHEET 8)
- ==== STANDARD DUTY CONCRETE (REF SHEET 8)
- ==== CONCRETE SIDEWALK (REF SHEET 8)

### NOTES

- ALL WORK TO CONFORM TO THE REQUIREMENTS OF THE GEOTECHNICAL REPORT.
- SOIL PREPARATION SHALL BE PER RECOMMENDATIONS FROM A GEOTECHNICAL ENGINEERING REPORT AS FOLLOWS:  
GEOTECHNICAL ENGINEER: KUMAR & ASSOCIATES, INC  
REPORT NO. 20-1-336, DATED JULY 2, 2020  
THE CONTRACTOR MUST FULLY REVIEW THE REPORTS PRIOR TO CONSTRUCTION. INFORMATION IN THE GEOTECHNICAL REPORT SUPERCEDES ANY CONFLICTING INFORMATION CONTAINED IN THE CONSTRUCTION PLANS AND SPECIFICATIONS.

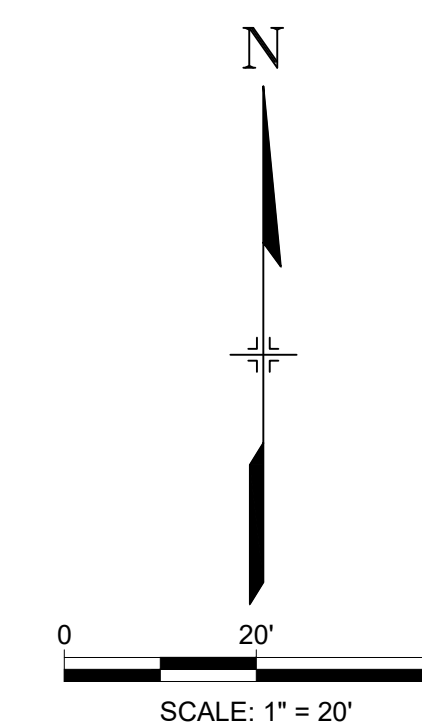

The Town of Parker review constitutes general compliance with the Town's Standards and approved variances, subject to these plans being stamped, signed, and dated by the professional engineer of record. Review by the Town does not constitute approval of the plan design or accuracy and correctness of engineering calculations. Errors in the design or calculations remain the responsibility of the registered professional engineer whose stamp and signature are affixed to this document.

This review does not constitute approval of any private on-site improvements which may be shown. Construction cannot commence until all required drainage/traffic report(s), final development plan(s), special review(s), grading permit, and/or other permits are complete, approved and on file with the Town of Parker.

Town of Parker, Director of Engineering \_\_\_\_\_ Date \_\_\_\_\_

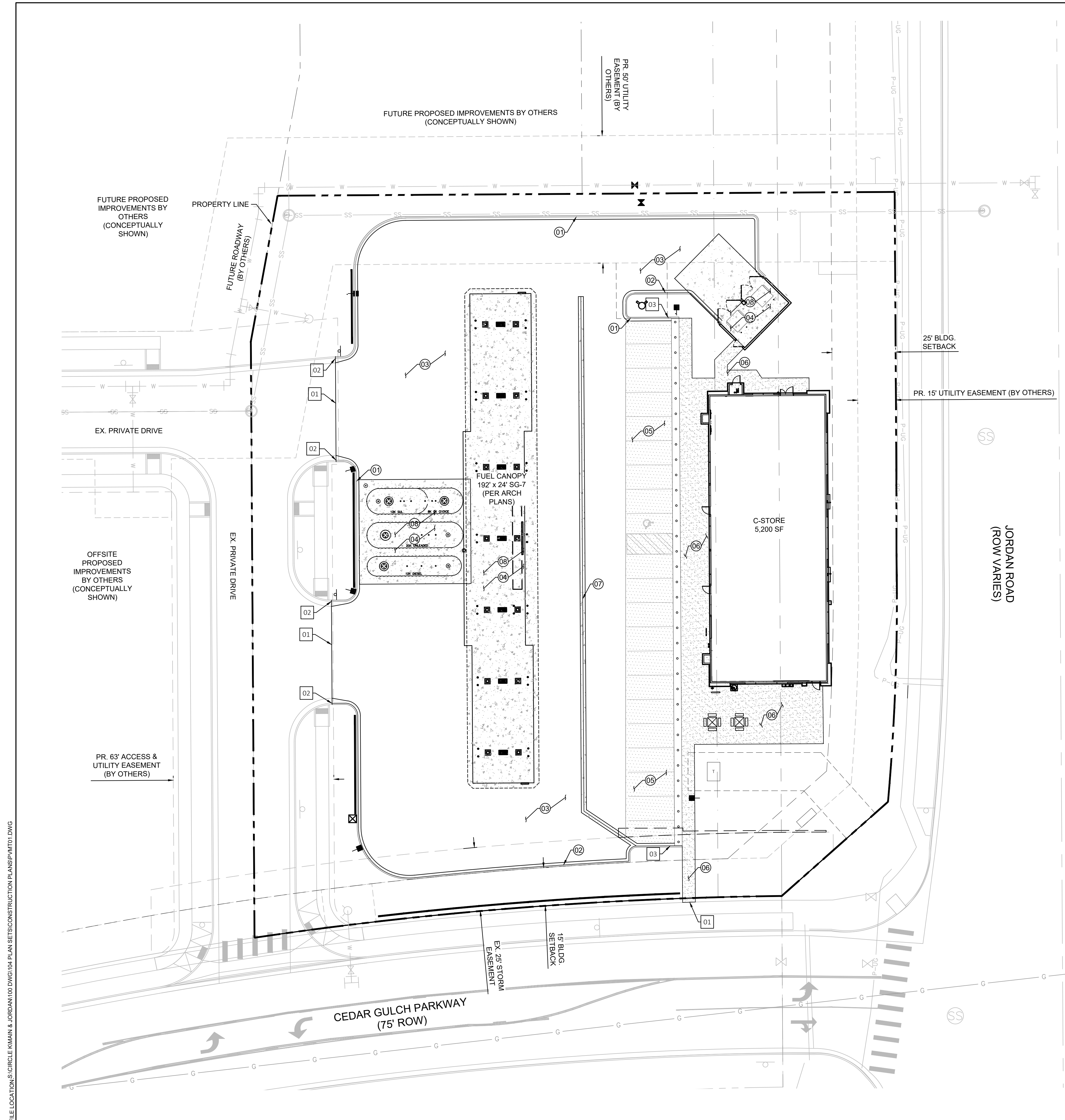

FILE LOCATION: S:\CIRCLE K\KIMM & JORDAN\1100 DIVISION 104 PLAN SETS\CONSTRUCTION PLANS\PW17.DWG



Know what's below.  
Call before you dig.



2435 RESEARCH PARKWAY, SUITE 300  
COLORADO SPRINGS, CO 80920  
PHONE: (719) 575-0100  
FAX: (719) 575-0208



LAND DEVELOPMENT  
CONSULTANTS, LLC

950 S. CHERRY STREET, SUITE 512  
DENVER, CO 80246

OWNER/DEVELOPER:



ROCKY MOUNTAINS DIVISION  
5500 S QUEBEC STREET, SUITE 100  
GREENWOOD VILLAGE, CO 80111

SEAL



FOR AND ON BEHALF OF MATRIX DESIGN GROUP, INC.  
CONTRACTOR IS RESPONSIBLE FOR OBTAINING THE  
MOST RECENT PROJECT CONSTRUCTION DOCUMENTS.  
MATRIX DESIGN GROUP IS NOT RESPONSIBLE FOR  
CHANGES, ALTERATIONS, OR USE OF CONSTRUCTION  
DOCUMENTS PRIOR TO JURISDICTIONAL APPROVAL.

VICINITY MAP: SCALE: N.T.S.

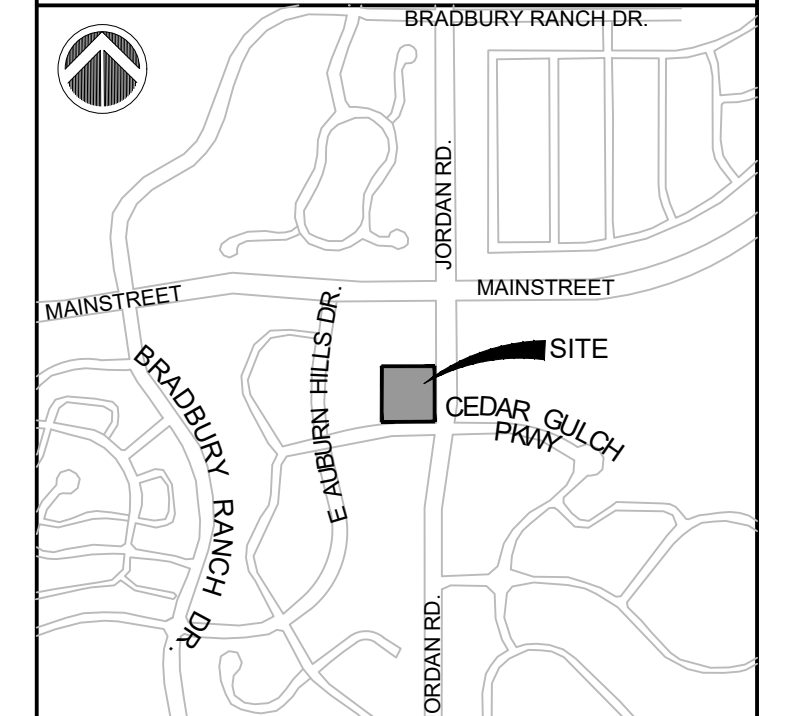

PROJECT:

CIRCLE K

CONSTRUCTION DOCUMENTS

16846 E AUBURN HILLS DRIVE  
PARKER, CO 80134

REVISION HISTORY:

NO.	DATE	DESCRIPTION	BY

DRAWING INFORMATION:

PROJECT NO: 21.1207.030

DRAWN BY: RAD

CHECKED BY: NMS

DESIGNED BY: NMS

SHEET TITLE:

PAVEMENT PLAN  
DETAILS

C3.1

SHEET 8 OF 26

DATE: NOVEMBER 2022

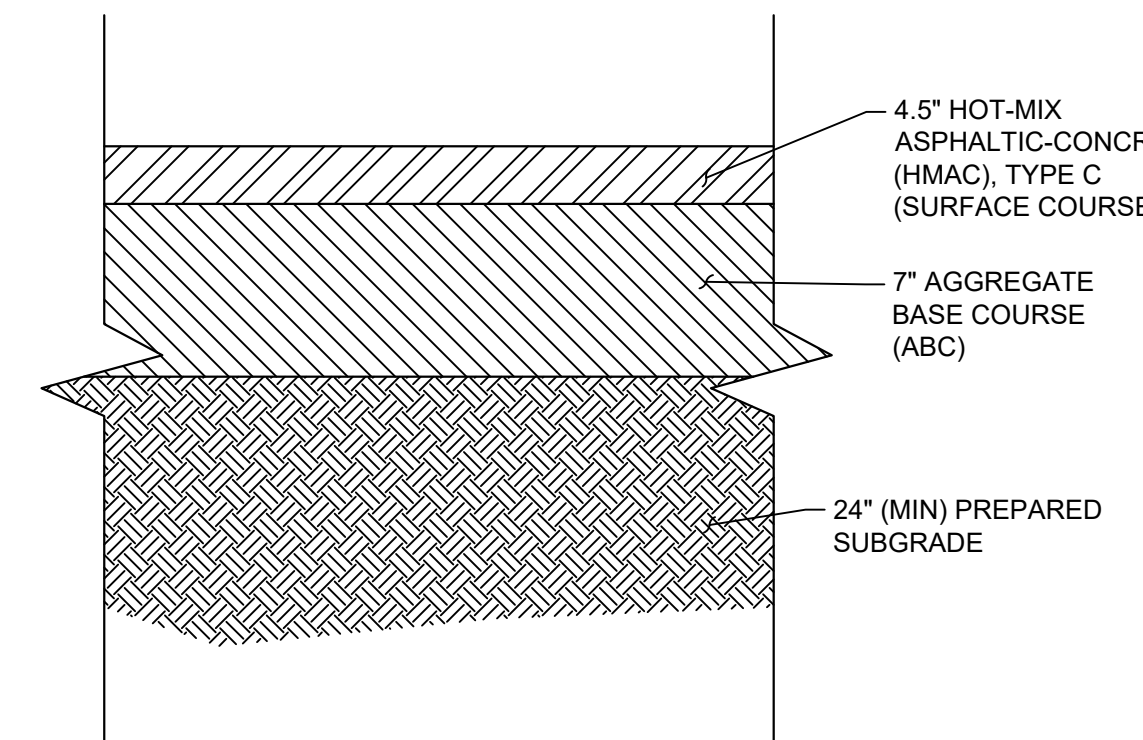

PRIOR TO CONSTRUCTION, CONTRACTOR SHALL VERIFY THE ABOVE DETAILS WITH THE GEOTECHNICAL REPORT PREPARED BY KUMAR & ASSOCIATES, INC. DATED JULY 2, 2020, PROJECT NUMBER 20-1-336

STANDARD DUTY  
ASPHALT (FLEXIBLE) PAVEMENT  
N.T.S.

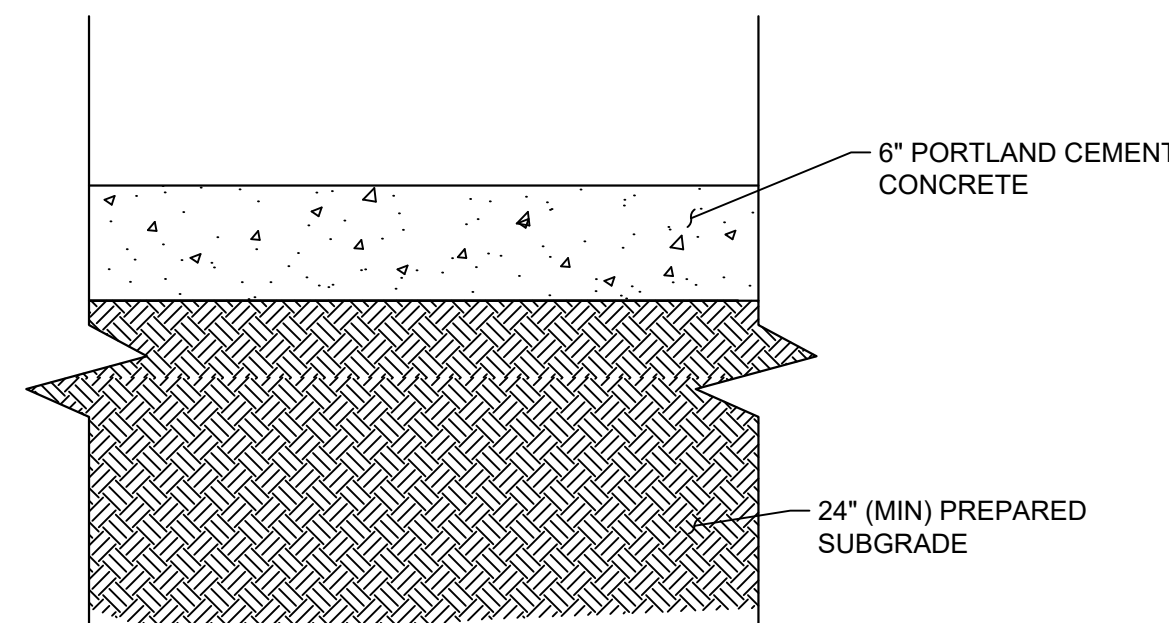

PRIOR TO CONSTRUCTION, CONTRACTOR SHALL VERIFY THE ABOVE DETAILS WITH THE GEOTECHNICAL REPORT PREPARED BY KUMAR & ASSOCIATES, INC. DATED JULY 2, 2020, PROJECT NUMBER 20-1-336

STANDARD DUTY  
CONCRETE (RIGID) PAVEMENT  
N.T.S.

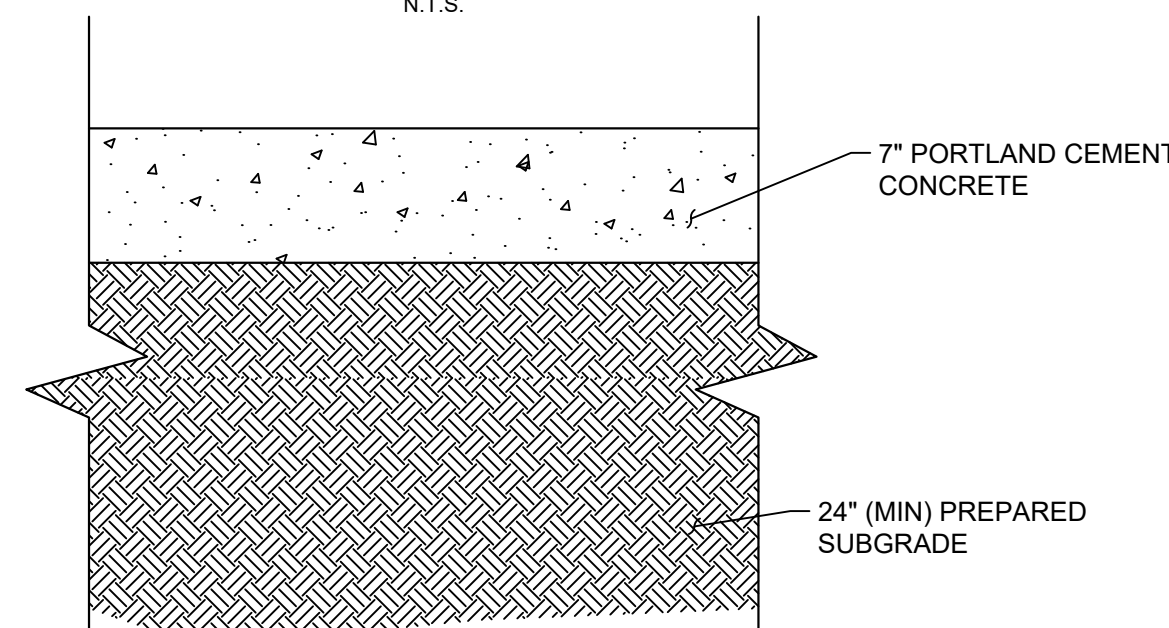

PRIOR TO CONSTRUCTION, CONTRACTOR SHALL VERIFY THE ABOVE DETAILS WITH THE GEOTECHNICAL REPORT PREPARED BY KUMAR & ASSOCIATES, INC. DATED JULY 2, 2020, PROJECT NUMBER 20-1-336

HEAVY DUTY  
CONCRETE (RIGID) PAVEMENT  
N.T.S.

- ASPHALT NOTES:
1. THE SOILS ENCOUNTERED CORRELATE TO AN A-2-4 CLASSIFICATION IN ACCORDANCE WITH THE AMERICAN ASSOCIATION FOR STATE HIGHWAY AND TRANSPORTATION OFFICIALS (AASHTO) STANDARD M-145 AND ARE CONSIDERED GOOD TO FAIR FOR USE AS SUBGRADE SUPPORT.
  2. THE RECOMMENDED SUBGRADE PREPARATION SHOULD CONSIST OF SCARIFYING THE NATIVE SOILS TO A DEPTH OF 12 INCHES. THE SCARIFIED SOIL SHOULD BE BROUGHT TO WITHIN ±2% OF OPTIMUM MOISTURE CONTENT AND COMPACTED TO 95% OF THE STANDARD PROCTOR DRY DENSITY (ASTM D698).

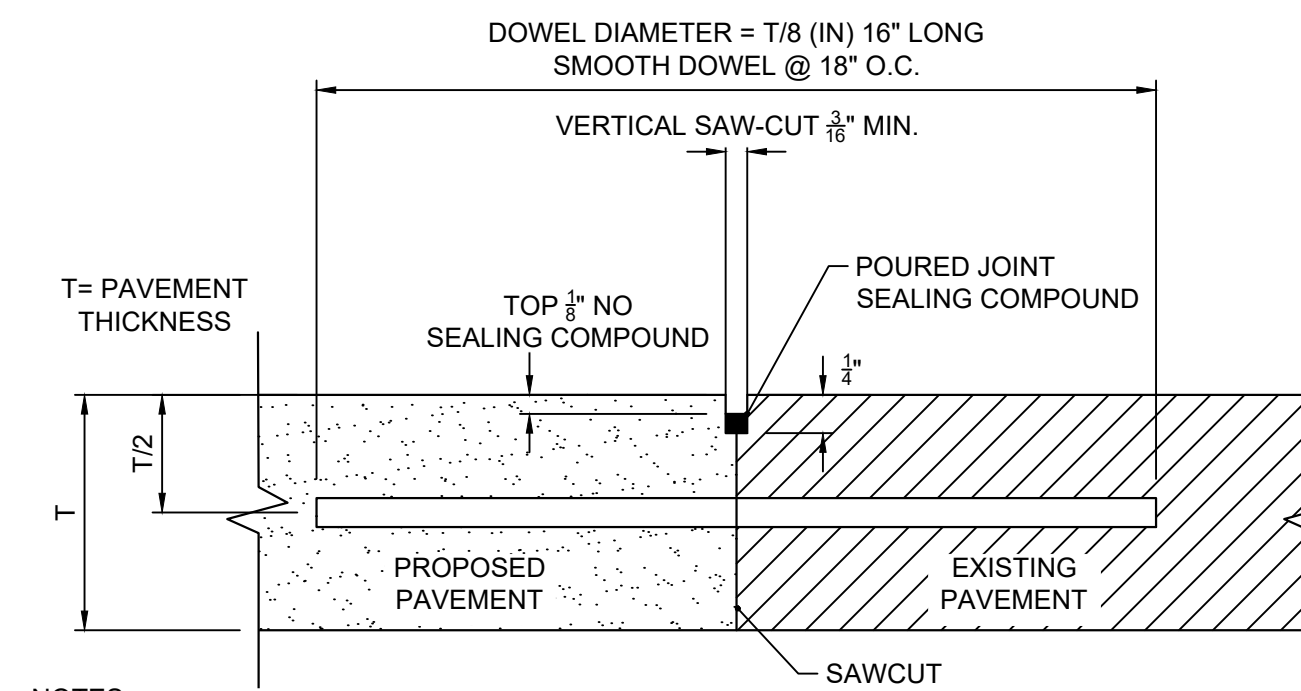

- NOTES:
1. DOWEL BARS SHALL BE DRILLED INTO PAVEMENT HORIZONTALLY BY USE OF MECHANICAL RIG.
  2. DRILLING BY HAND IS NOT ACCEPTABLE, PUSHING DOWEL BARS INTO GREEN CONCRETE IS NOT ACCEPTABLE.

BUTT JOINT  
N.T.S.

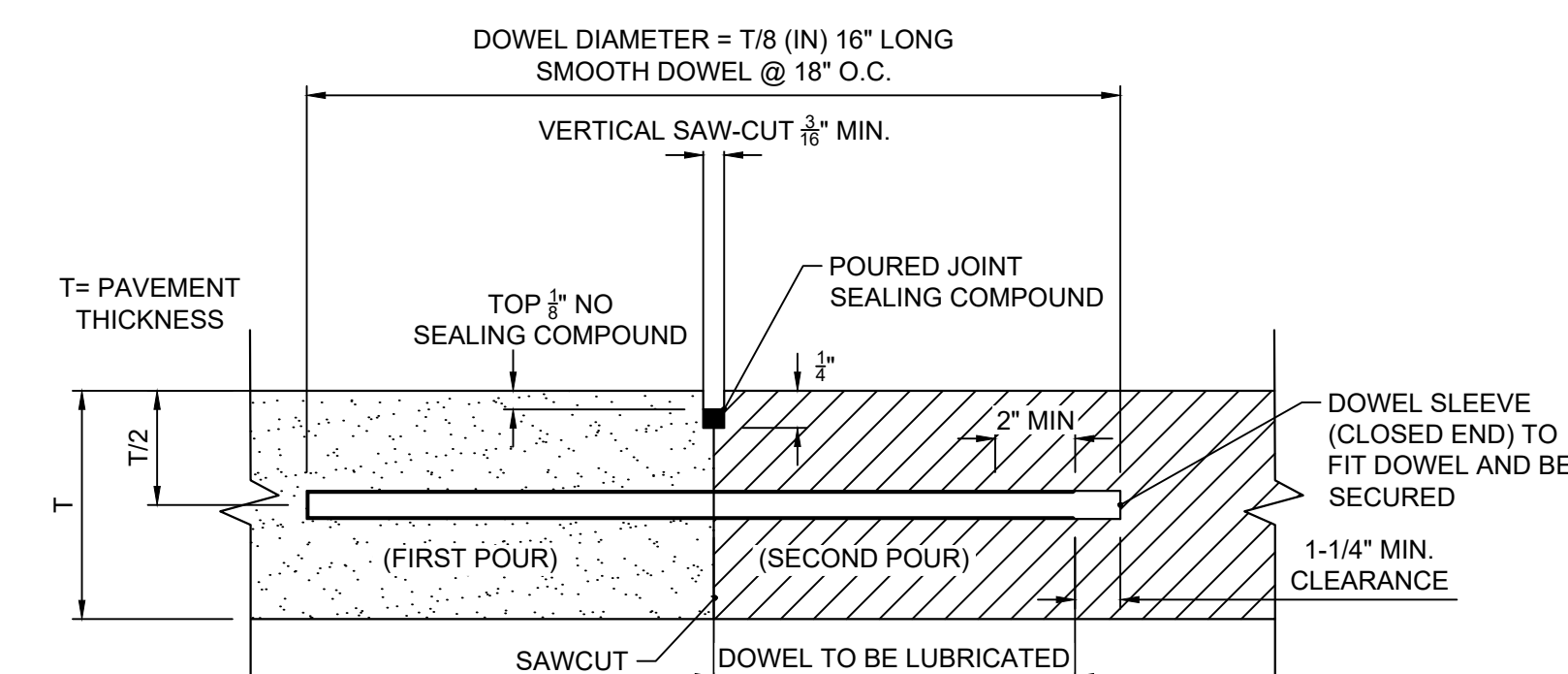

- NOTES:
1. DOWELS SHALL BE SUPPORTED BY AN APPROVED DEVICE.

CONSTRUCTION JOINT  
N.T.S.

- CONCRETE NOTES:
1. A RIGID PAVEMENT SECTION IS RECOMMENDED IN AREAS OF FUEL TRANSPORT VEHICLES IN THE VICINITY OF THE UNDERGROUND FUEL STORAGE TANKS AND WASTE DISPOSAL RECEPTACLES. IT IS RECOMMENDED THAT THE PAVEMENT SECTION FOR THE ACCOMMODATION OF SUCH SHOULD EXTEND OUT A SUFFICIENT DISTANCE TO ACCOMMODATE THE ENTIRE LENGTH OF THE WASTE DISPOSAL VEHICLE ITSELF.
  2. THE RECOMMENDED SUBGRADE PREPARATION SHOULD CONSIST OF SCARIFYING THE NATIVE SOILS TO A DEPTH OF 12 INCHES. THE SCARIFIED SOIL SHOULD BE BROUGHT TO WITHIN ±2% OF OPTIMUM MOISTURE CONTENT AND COMPACTED TO 95% OF THE STANDARD PROCTOR DRY DENSITY (ASTM D698).
  3. THE CONCRETE TO BE USED IN CONSTRUCTION WAS ASSUMED TO HAVE AN ELASTIC MODULUS OF 3.8x10<sup>6</sup> PSI AND A MEAN MODULUS OF RUPTURE OF 650 PSI. THIS WOULD GENERALLY CORRESPOND TO A 28-DAY CYLINDER STRENGTH OF 4,400 PSI AS DETERMINED IN ACCORDANCE WITH ASTM C39. A WORKING STRESS OF 80,000 PSI (CORRESPONDING TO GRADE 60) WAS ASSUMED FOR THE REINFORCING STEEL.
  4. IT IS RECOMMENDED THE CONCRETE SLAB BE CONSTRUCTED TO ALLOW RAPID DRAINAGE OF SURFACE RUNOFF AWAY FROM THE SOIL DIRECTLY UNDERLYING THE PAVEMENT SECTION.

The Town of Parker review constitutes general compliance with the Town's Standards and approved variances, subject to these plans being stamped, signed, and dated by the professional engineer of record. Review by the Town does not constitute approval of the plan design or accuracy and correctness of engineering calculations. Errors in the design or calculations remain the responsibility of the registered professional engineer whose stamp and signature are affixed to this document.

This review does not constitute approval of any private on-site improvements which may be shown. Construction cannot commence until all required drainage/traffic report(s), final development plan(s), special review(s), grading permit, and/or other permits are complete, approved and on file with the Town of Parker.

Town of Parker, Director of Engineering Date



Know what's below.  
Call before you dig.



2435 RESEARCH PARKWAY, SUITE 300  
COLORADO SPRINGS, CO 80920  
PHONE: (719) 575-0100  
FAX: (719) 575-0208



LAND DEVELOPMENT  
CONSULTANTS, LLC

950 S. CHERRY STREET, SUITE 512  
DENVER, CO 80246

OWNER/DEVELOPER:



ROCKY MOUNTAINS DIVISION  
5500 S. QUEBEC STREET, SUITE 100  
GREENWOOD VILLAGE, CO 80111

SEAL



FOR AND ON BEHALF OF MATRIX DESIGN GROUP, INC  
CONTRACTOR IS RESPONSIBLE FOR OBTAINING THE  
MOST RECENT PROJECT CONSTRUCTION DOCUMENTS.  
MATRIX DESIGN GROUP IS NOT RESPONSIBLE FOR  
CHANGES, ALTERATIONS, OR USE OF CONSTRUCTION  
DOCUMENTS PRIOR TO JURISDICTIONAL APPROVAL.

VICINITY MAP: SCALE: NTS

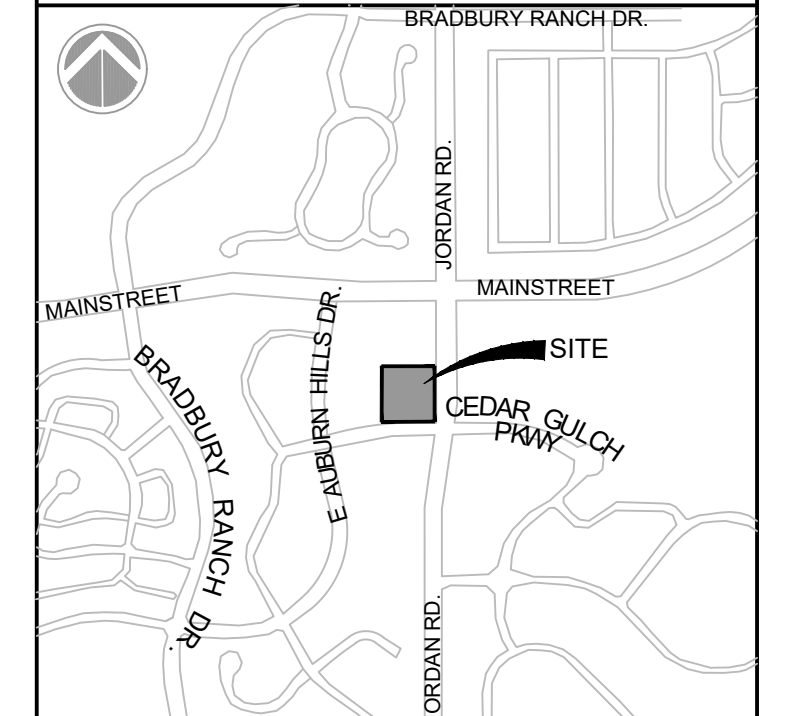

PROJECT:

**CIRCLE K**

**CONSTRUCTION DOCUMENTS**

16846 E AUBURN HILLS DRIVE  
PARKER, CO 80134

REVISION HISTORY:

NO.	DATE	DESCRIPTION	BY

DRAWING INFORMATION:

PROJECT NO: 21.1207.030

DRAWN BY: RAD

CHECKED BY: NMS

DESIGNED BY: NMS

SHEET TITLE:

**CBMP PLAN  
(INITIAL)**

**C4.0**

**SHEET 9 OF 26**

DATE: NOVEMBER 2022

### SITE LEGEND

- PROPERTY BOUNDARY LINE
- SETBACK LINE
- EASEMENT BOUNDARY LINE
- PROPOSED CONCRETE CURB & GUTTER
- OVERLAND FLOW
- PROPOSED CONTOURS
- EXISTING CONTOURS

### EROSION CONTROL LEGEND

- SF SILT FENCE
- VTC VEHICLE TRACKING CONTROL
- CWA CONCRETE WASHOUT
- SSA STABILIZED STAGING AREA
- IPCOS INLET PROTECTION
- SCL SEDIMENT CONTROL LOG
- DTC DEBRIS AND TRASH CONTROL
- DP DETENTION PROTECTION
- PTP PORTABLE TOILET
- HP HP HIGH POINT / LOW POINT
- SMC SEEDING, MULCHING & CRIMPING
- SR SURFACE ROUGHENING
- LOC LIMITS OF DISTURBANCE/ CONSTRUCTION SITE BOUNDARY

### SEQUENCE OF CONSTRUCTION

- INSTALL STABILIZED CONSTRUCTION ENTRANCE
- PREPARE TEMPORARY PARKING AND STORAGE AREA
- INSTALL CONSTRUCTION FENCE
- CLEAR AND GRUB THE SITE
- BEGIN GRADING THE SITE
- BEGIN CONSTRUCTION OF BUILDING PAD AND STRUCTURES
- INSTALL UTILITIES, CURB AND GUTTER
- PREPARE SITE FOR PAVING
- PAVE SITE
- COMPLETE GRADING AND INSTALL PERMANENT SEEDING AND PLANTING
- REMOVE ALL TEMPORARY EROSION AND SEDIMENT CONTROL DEVICES ONCE SITE IS STABILIZED

#### NOTE:

- ALL WORK WITHIN PUBLIC RIGHT-OF-WAY (ROW) WILL REQUIRE A TOWN ROW PERMIT. INITIAL AND INTERIM CBMPs FOR WORK WITHIN THE TOWN'S ROW SHALL BE COORDINATED WITH THE TOWN'S ENVIRONMENTAL INSPECTOR PRIOR TO THE BEGINNING OF ANY ROW WORK.
- LOT PROTECTION (LP) IS REQUIRED ON COMMERCIAL LOTS WHEN LANDSCAPING IS NOT POSSIBLE.
- TO REDUCE THE POTENTIAL FOR CLOGGING OF DEBRIS GRATES, NO STRAW MULCH SHALL BE USED WITHIN THE EXCESS URBAN RUNOFF VOLUME OF A DETENTION BASIN. INSTEAD, EROSION CONTROL BLANKET SHALL BE INSTALLED FOR A WIDTH OF AT LEAST 6-FEET ON BOTH SIDES OF THE CONCRETE LOW FLOW CHANNELS OR UP TO A DEPTH OF 1-FOOT IN SOIL RIPRAP OR BENCHED LOW FLOW CHANNELS. ADDITIONALLY, HYDRAULICALLY-APPLIED WOOD FIBER MULCH, STABILIZED FIBER MATRIX, BONDED FIBER MATRIX, OR FLEXIBLE GROWTH MEDIUM SHALL BE USED IN ALL OTHER AREAS WITHIN THE EXCESS URBAN RUNOFF VOLUME OF THE DETENTION BASIN. THE BLANKET AND HYDRAULICALLY-APPLIED MULCH SHALL COMPLY WITH THE MATERIALS AND INSTALLATION REQUIREMENTS FOR EROSION CONTROL BLANKETS AS REQUIRED BY THE TOWN'S CBMP PROGRAM, AND WHERE APPLICABLE, THE PRODUCT MANUFACTURER.
- SEE LANDSCAPE PLANS MIX.
- ANY ONSITE BULK FUEL STORAGE REQUIRES A FIRE LIFE SAFETY PERMIT FROM THE TOWN OF PARKER PRIOR TO INSTALLATION.

The Town of Parker review constitutes general compliance with the Town's Standards and approved variances, subject to these plans being stamped, signed, and dated by the professional engineer of record. Review by the Town does not constitute approval of the plan design or accuracy and correctness of engineering calculations. Errors in the design or calculations remain the responsibility of the registered professional engineer whose stamp and signature are affixed to this document.

This review does not constitute approval of any private on-site improvements which may be shown. Construction cannot commence until all required drainage/traffic report(s), final development plan(s), special review(s), grading permit, and/or other permits are complete, approved and on file with the Town of Parker.

Town of Parker, Director of Engineering Date

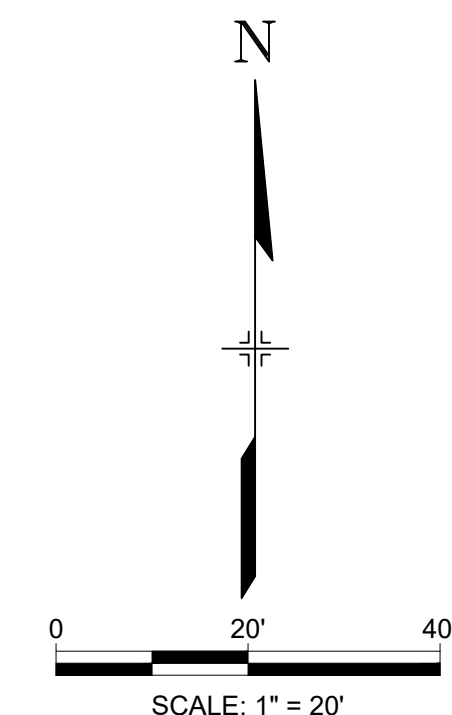
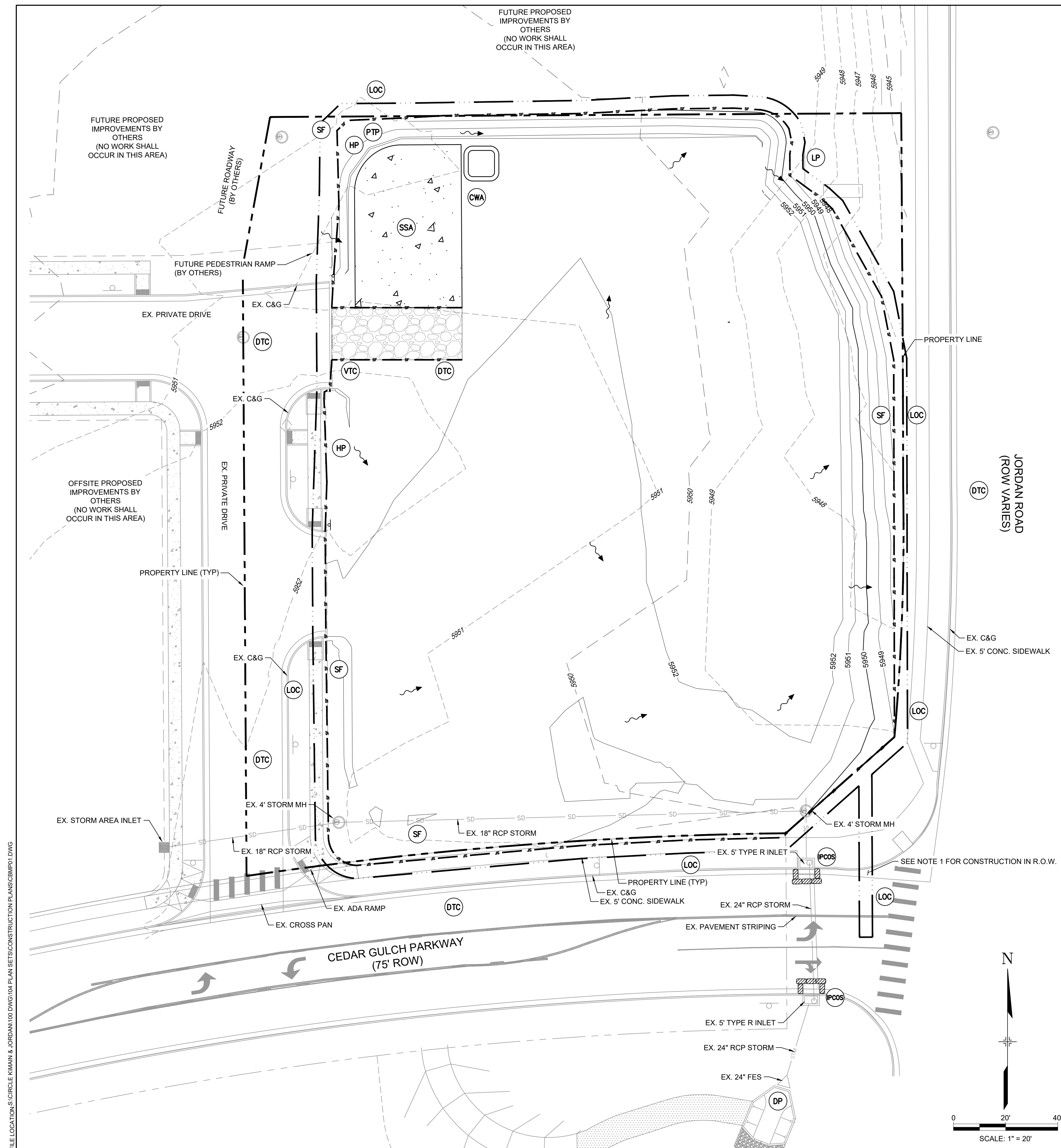

FILE LOCATION: S:\CIRCLE K\MIAMI & JORDAN\1100 DIVISION\104 PLAN SETS\CONSTRUCTION PLANS\C4.0\CBMP.dwg



**Matrix**  
 2435 RESEARCH PARKWAY, SUITE 300  
 COLORADO SPRINGS, CO 80920  
 PHONE: (719) 575-0100  
 FAX: (719) 575-0208

**LAND DEVELOPMENT CONSULTANTS, LLC**  
 950 S. CHERRY STREET, SUITE 512  
 DENVER, CO 80246

OWNER/DEVELOPER:



ROCKY MOUNTAINS DIVISION  
 5500 S QUEBEC STREET, SUITE 100  
 GREENWOOD VILLAGE, CO 80111

SEAL

*Colorado Licensed Professional Engineer*  
 MICHAEL W. SCHWAB  
 20134

FOR AND ON BEHALF OF MATRIX DESIGN GROUP, INC. CONTRACTOR IS RESPONSIBLE FOR OBTAINING THE MOST RECENT PROJECT CONSTRUCTION DOCUMENTS. MATRIX DESIGN GROUP IS NOT RESPONSIBLE FOR CHANGES, ALTERATIONS, OR USE OF CONSTRUCTION DOCUMENTS PRIOR TO JURISDICTIONAL APPROVAL.

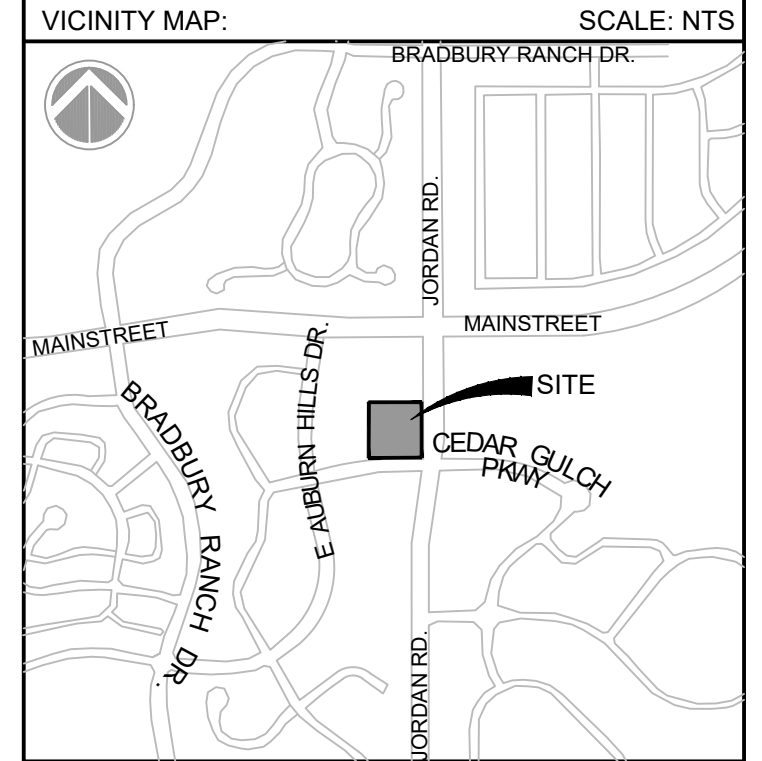

PROJECT:  
**CIRCLE K**  
**CONSTRUCTION DOCUMENTS**  
 16846 E AUBURN HILLS DRIVE  
 PARKER, CO 80134

REVISION HISTORY:

NO.	DATE	DESCRIPTION	BY

DRAWING INFORMATION:  
 PROJECT NO: 21.1207.030  
 DRAWN BY: RAD  
 CHECKED BY: NMS  
 DESIGNED BY: NMS

SHEET TITLE:  
**CBMP PLAN (INTERIM & FINAL)**

**C4.1**  
 SHEET 10 OF 26

DATE: NOVEMBER 2022

**SITE LEGEND**

- PROPERTY BOUNDARY LINE
- - - SETBACK LINE
- - - EASEMENT BOUNDARY LINE
- ==== PROPOSED CONCRETE CURB & GUTTER
- ~> OVERLAND FLOW
- ~> 7050 PROPOSED CONTOURS
- ~> 5975 EXISTING CONTOURS

**EROSION CONTROL LEGEND**

- SF SILT FENCE
- VTC VEHICLE TRACKING CONTROL
- CWA CONCRETE WASHOUT
- SSA STABILIZED STAGING AREA
- IPCOS INLET PROTECTION
- SCL SEDIMENT CONTROL LOG
- DTC DEBRIS AND TRASH CONTROL
- DP DETENTION PROTECTION
- PTP PORTABLE TOILET
- HP LP HIGH POINT / LOW POINT
- SMC SEEDING, MULCHING & CRIMPING
- SR SURFACE ROUGHENING
- LOC LIMITS OF DISTURBANCE/ CONSTRUCTION SITE BOUNDARY

**SEQUENCE OF CONSTRUCTION**

1. INSTALL STABILIZED CONSTRUCTION ENTRANCE
2. PREPARE TEMPORARY PARKING AND STORAGE AREA
3. INSTALL CONSTRUCTION FENCE
4. CLEAR AND GRUB THE SITE
5. BEGIN GRADING THE SITE
6. BEGIN CONSTRUCTION OF BUILDING PAD AND STRUCTURES
7. INSTALL UTILITIES, CURB AND GUTTER
8. PREPARE SITE FOR PAVING
9. PAVE SITE
10. COMPLETE GRADING AND INSTALL PERMANENT SEEDING AND PLANTING
11. REMOVE ALL TEMPORARY EROSION AND SEDIMENT CONTROL DEVICES ONCE SITE IS STABILIZED

**NOTE:**

1. ALL WORK WITHIN PUBLIC RIGHT-OF-WAY (ROW) WILL REQUIRE A TOWN ROW PERMIT. INITIAL AND INTERIM CBMPS FOR WORK WITHIN THE TOWN'S ROW SHALL BE COORDINATED WITH THE TOWN'S ENVIRONMENTAL INSPECTOR PRIOR TO THE BEGINNING OF ANY ROW WORK.
2. LOT PROTECTION (LP) IS REQUIRED ON COMMERCIAL LOTS WHEN LANDSCAPING IS NOT POSSIBLE.
3. TO REDUCE THE POTENTIAL FOR CLOGGING OF DEBRIS GRATES, NO STRAW MULCH SHALL BE USED WITHIN THE EXCESS URBAN RUNOFF VOLUME OF A DETENTION BASIN. INSTEAD, EROSION CONTROL BLANKET SHALL BE INSTALLED FOR A WIDTH OF AT LEAST 6-FEET ON BOTH SIDES OF THE CONCRETE LOW FLOW CHANNELS OR UP TO A DEPTH OF 1-FOOT IN SOIL. RIPRAP OR BENCHED LOW FLOW CHANNELS. ADDITIONALLY, HYDRAULICALLY-APPLIED WOOD FIBER MULCH, STABILIZED FIBER MATRIX, BONDED FIBER MATRIX, OR FLEXIBLE GROWTH MEDIUM SHALL BE USED IN ALL OTHER AREAS WITHIN THE EXCESS URBAN RUNOFF VOLUME OF THE DETENTION BASIN. THE BLANKET AND HYDRAULICALLY-APPLIED MULCH SHALL COMPLY WITH THE MATERIALS AND INSTALLATION REQUIREMENTS FOR EROSION CONTROL BLANKETS AS REQUIRED BY THE TOWN'S CBMP PROGRAM, AND WHERE APPLICABLE, THE PRODUCT MANUFACTURER.
4. SEE LANDSCAPE PLANS MIX.

The Town of Parker review constitutes general compliance with the Town's Standards and approved variances, subject to these plans being stamped, signed, and dated by the professional engineer of record. Review by the Town does not constitute approval of the plan design or accuracy and correctness of engineering calculations. Errors in the design or calculations remain the responsibility of the registered professional engineer whose stamp and signature are affixed to this document.





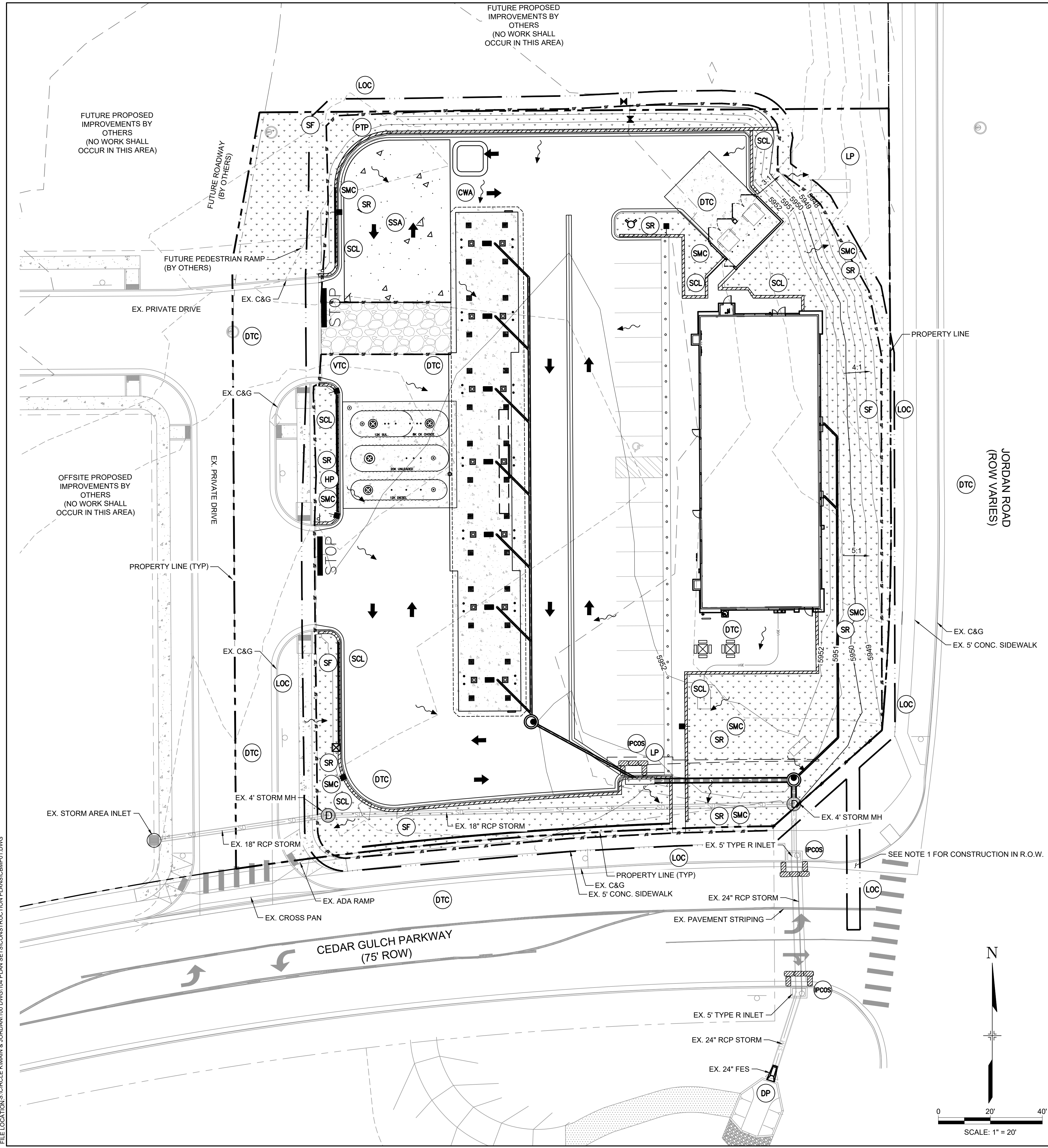





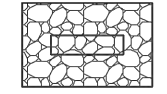

This review does not constitute approval of any private on-site improvements which may be shown. Construction cannot commence until all required drainage/traffic report(s), final development plan(s), special review(s), grading permit, and/or other permits are complete, approved and on file with the Town of Parker.

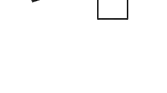
Town of Parker, Director of Engineering \_\_\_\_\_ Date \_\_\_\_\_



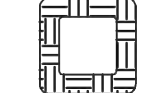











FILE LOCATION: S:\CIRCLE K\MAIN & JORDAN\1100 DIVISION\104 PLAN SETS\CONSTRUCTION PLANS\C4.1\CBMP.dwg

NO CHANGES ARE TO BE MADE TO THIS DRAWING WITHOUT WRITTEN PERMISSION OF THE TOWN OF PARKER.

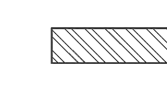
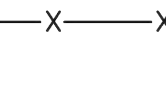
-  **CD** CHECK DAM
-  **CF** CONSTRUCTION FENCE
-  **CP** CULVERT PROTECTION
-  **CWA** CONCRETE WASHOUT AREA
-  **D** DEWATERING
-  **DD** DIVERSION DITCH
-  **DP** DETENTION POND PROTECTION
-  **DTC** DEBRIS TRASH CONTROL
-  **ECB** EROSION CONTROL BLANKET
-  **IPAN** INLET PROTECTION FOR AREA INLETS NOT IN PAVEMENT
-  **IPAP** INLET PROTECTION FOR AREA INLETS IN PAVEMENT
-  **IPCOG** INLET PROTECTION, CURB ON-GRADE, TYPE R INLET
-  **IPCOS** INLET PROTECTION, CURB ON SUMP, TYPE R INLET



 **CBMP** CONSTRUCTION BEST MANAGEMENT PRACTICES **LEGEND** 1 OF 3 Oct. 2013

NO CHANGES ARE TO BE MADE TO THIS DRAWING WITHOUT WRITTEN PERMISSION OF THE TOWN OF PARKER.

-  **LP** LOT PROTECTION
-  **MWP** MASONRY WORK PROTECTION
-  **PTP** PORTABLE TOILET PROTECTION
-  **RCSC** ROUGH CUT STREET CONTROL
-  **RS** ROCK SOCK
-  **RSS** ROCK SOCK IN SWALE
-  **SB** STRAW BALE
-  **SCL** SEDIMENT CONTROL LOGS
-  **SF** SILT FENCE
-  **SMC** SEEDING, MULCHING AND CRIMPING
-  **SR** SURFACE ROUGHING
-  **SSA** STABILIZED STAGING AREA
-  **STP** SIDEWALK TRANSITION PROTECTION

 **CBMP** CONSTRUCTION BEST MANAGEMENT PRACTICES **LEGEND** 2 OF 3 Oct. 2013

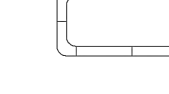
NO CHANGES ARE TO BE MADE TO THIS DRAWING WITHOUT WRITTEN PERMISSION OF THE TOWN OF PARKER.

-  **TI** TEMPORARY IRRIGATION
-  **TSB** TEMPORARY SEDIMENT BASIN
-  **VTC** VEHICLE TRACKING CONTROL

 **CBMP** CONSTRUCTION BEST MANAGEMENT PRACTICES **LEGEND** 3 OF 3 Oct. 2013



**CONSULTANTS:**  
  
 2435 RESEARCH PARKWAY, SUITE 300  
 COLORADO SPRINGS, CO 80920  
 PHONE: (719) 575-0100  
 FAX: (719) 575-0208  
  
**LAND DEVELOPMENT**  
 CONSULTANTS, LLC  
 950 S. CHERRY STREET, SUITE 512  
 DENVER, CO 80246

**OWNER/DEVELOPER:**  
  
 ROCKY MOUNTAINS DIVISION  
 5500 S QUEBEC STREET, SUITE 100  
 GREENWOOD VILLAGE, CO 80111

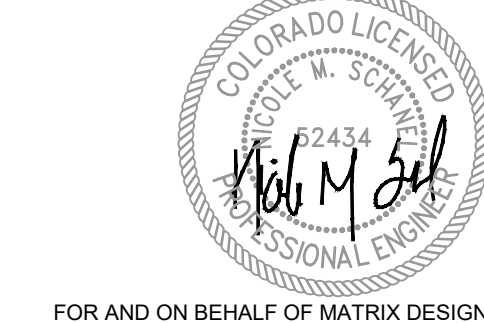
**SEAL**  
  
 FOR AND ON BEHALF OF MATRIX DESIGN GROUP, INC  
 CONTRACTOR IS RESPONSIBLE FOR OBTAINING THE  
 MOST RECENT PROJECT CONSTRUCTION DOCUMENTS.  
 MATRIX DESIGN GROUP IS NOT RESPONSIBLE FOR  
 CHANGES, ALTERATIONS, OR USE OF CONSTRUCTION  
 DOCUMENTS PRIOR TO JURISDICTIONAL APPROVAL.

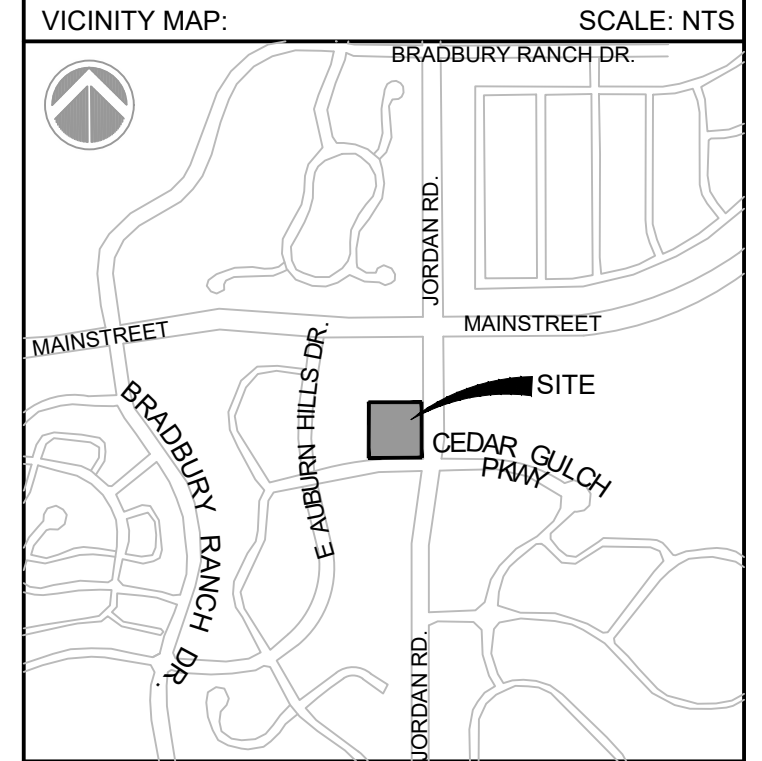

**PROJECT:**  
**CIRCLE K**  
**CONSTRUCTION DOCUMENTS**  
 16846 E AUBURN HILLS DRIVE  
 PARKER, CO 80134

**REVISION HISTORY:**

NO.	DATE	DESCRIPTION	BY

**DRAWING INFORMATION:**  
 PROJECT NO: 21.1207.030  
 DRAWN BY: RAD  
 CHECKED BY: NMS  
 DESIGNED BY: NMS

**SHEET TITLE:**  
**CBMP LEGEND**

**C4.2**  
**SHEET 11 OF 26**

DATE: NOVEMBER 2022

FILE LOCATION: S:\CIRCLE K\MAN & JORDAN\100 DWG\104 PLAN SETS\CONSTRUCTION PLANS\CBMP1.DWG

NO CHANGES ARE TO BE MADE TO THIS DRAWING WITHOUT WRITTEN PERMISSION OF THE TOWN OF PARKER.

- GRADING, DRILLING, CLEARING, EXCAVATING, BACK-FILLING, SOIL STRIPPING, SOIL IMPORTING EXPORTING OR ANY OTHER FORM OF SOIL DISTURBANCE SHALL NOT COMMENCE UNTIL A TOWN OF PARKER GRADING/EXCAVATION PERMIT HAS BEEN ISSUED.
- THE TOWN OF PARKER GRADING/EXCAVATION PERMIT IS VALID FOR A PERIOD OF 2 YEARS FROM THE DATE OF ISSUANCE. ANY LAPSE IN PERMIT COVERAGE MAY RESULT IN THE ISSUANCE OF A STOP WORK ORDER AND/OR FINES.
- ALL EROSION AND SEDIMENT CONTROL BMPs SHALL BE INSTALLED ACCORDING TO THE CBMP PLAN INSTALLATION NOTES AND DETAILS AND/OR PERMITTED VARIANCES. ALL MATERIALS, WORKMANSHIP AND INSTALLATION METHODS ARE SUBJECT TO INSPECTION BY THE TOWN'S INSPECTOR. THE TOWN OF PARKER RESERVES THE RIGHT TO ACCEPT OR REJECT ANY SUCH MATERIALS, WORKMANSHIP AND/OR INSTALLATION METHODS THAT DO NOT CONFORM TO THE CBMP PLAN AND/OR PERMITTED VARIANCES.
- THE EROSION CONTROL SUPERVISOR SHALL REVISE OR MODIFY THE EROSION AND SEDIMENT CONTROL MEASURES IF IT BECOMES APPARENT THAT THE ORIGINAL PLAN IS INADEQUATE, OR AS A RESULT OF DEFICIENCIES IDENTIFIED DURING INSPECTIONS PERFORMED BY THE TOWN'S INSPECTOR.
- THE INSTALLATION OF ADDITIONAL EROSION AND SEDIMENT CONTROL BEST MANAGEMENT PRACTICES (BMPs) MAY BE REQUIRED OF THE EROSION CONTROL SUPERVISOR, PROPERTY OWNER, SITE DEVELOPER, CONTRACTOR AND/OR THEIR AUTHORIZED AGENTS AT ANY TIME THROUGHOUT THE DURATION OF THE PROJECT CONSTRUCTION AND/OR SUBSEQUENT REVEGETATION PERIOD.
- THE EROSION CONTROL SUPERVISOR SHALL BE RESPONSIBLE FOR ENSURING THAT THE SITE REMAINS IN COMPLIANCE WITH THE NOTICE OF NUISANCE REPORTS (e.g., CONSTRUCTION SITE RUNOFF CONTROL INSPECTION REPORTS), APPROVED CBMP PLAN(S) AND THE TOWN OF PARKER STORM DRAINAGE AND ENVIRONMENTAL CRITERIA MANUAL.
- THE EROSION CONTROL SUPERVISOR SHALL BE READILY AVAILABLE TO DISCUSS AND CORRECT ANY PROBLEMS THAT MAY ARISE RELATING TO GRADING, EROSION AND SEDIMENT CONTROL.
- IF IT IS ANTICIPATED THAT ALL OR A PORTION OF THE PROJECT WILL OCCUR DURING SEASONS SUSCEPTIBLE TO SNOWFALL, THE USE OF CERTAIN EROSION AND SEDIMENT CONTROL BMPs ADJACENT TO PUBLIC ROADWAYS MAY NEED TO BE RECONSIDERED DUE TO THE NATURE OF SNOW REMOVAL OPERATIONS. AN APPROVED ALTERNATIVE MAY BE NECESSARY TO MINIMIZE DAMAGE FROM THESE OPERATIONS. THE TOWN OF PARKER ASSUMES NO RESPONSIBILITY FOR DAMAGE TO ANY BMPs AS A RESULT OF SNOW FLOWING AND SNOW REMOVAL.
- AREAS OF LAND DISTURBANCE EQUAL TO 40 ACRES OR GREATER SHALL NOT BE EXPOSED FOR MORE THAN 30 CONSECUTIVE DAYS WITHOUT TEMPORARY OR PERMANENT STABILIZATION.
- AUTHORIZED EXEMPTIONS MAY BE ALLOWED TO THE 40-ACRE LIMIT FOR REMOVAL AND STORAGE OF CUT MATERIAL WHERE (A) GEOTECHNICAL LIMITATIONS RESTRICT THE USE OF TEMPORARY OR PERMANENT STABILIZATION OF THE STORED MATERIAL (E.G., SWELLING SOILS, ROCK) AND (B) WHEN THE OWNER CAN DEMONSTRATE THAT THE 40-ACRE LIMIT IS PHYSICALLY AND/OR FINANCIALLY IMPRACTICABLE. FOR SITES GRANTED THIS EXEMPTION, A PHASING AND EARTHWORK QUANTITIES PLAN SHALL BE SUBMITTED TO THE PUBLIC WORKS DEPARTMENT AND APPROVED PRIOR TO THE COMMENCEMENT OF LAND DISTURBANCE ACTIVITIES. SUBMITTAL REQUIREMENTS INCLUDE:
  - PHASING PLAN SHOWING CUT AND FILL VOLUMES AND LOCATIONS FOR EACH PHASE AND PROJECT TOTALS.
  - EARTHWORK QUANTITY PLAN SHOWING CUT AND FILL VOLUMES AND LOCATIONS FOR EACH PHASE AND PROJECT TOTALS.
  - BMP PLAN SHOWING SPECIFIC EROSION AND SEDIMENT CONTROLS FOR EACH PHASE.

**CBMP** CONSTRUCTION BEST MANAGEMENT PRACTICES  
**GEN NOTES** 1 OF 4 Oct. 2013

NO CHANGES ARE TO BE MADE TO THIS DRAWING WITHOUT WRITTEN PERMISSION OF THE TOWN OF PARKER.

- ANY EROSION AND SEDIMENT CONTROL BMPs THAT ARE DAMAGED OR IN NEED OF MAINTENANCE OR REPLACEMENT SHALL BE CORRECTED AS SOON AS POSSIBLE, IMMEDIATELY IN MOST CASES.
- ALL DEFICIENCIES LISTED ON THE NOTICE OF NUISANCE FORM SHALL BE COMPLETED AS SOON AS POSSIBLE, IMMEDIATELY IN MOST CASES. ALL REQUIRED ACTIONS MUST BE IN THE CORRECTED FORM DURING THE FOLLOW-UP INSPECTION.
- THE EROSION CONTROL SUPERVISOR IS RESPONSIBLE FOR ENSURING THAT ALL STREETS, CURBS, GUTTERS, SIDEWALKS, DRIVEWAYS, PARKING LOTS, ALLEYS, TRICKLE CHANNELS, AND/OR OTHER IMPERVIOUS SURFACES IMPACTED BY CONSTRUCTION ACTIVITIES ARE THOROUGHLY CLEANED THROUGHOUT THE DAY IF THEY BECOME SOILED. THESE AREAS MUST ALSO BE THOROUGHLY CLEAN BEFORE THE END OF THE WORK DAY.
- BULK STORAGE STRUCTURES FOR PETROLEUM PRODUCTS AND OTHER CHEMICALS SHALL HAVE ADEQUATE PROTECTION SO AS TO CONTAIN ALL SPILLS AND PREVENT ANY SPILLED MATERIAL FROM ENTERING STATE WATERS.
- ALL TRASH RECEPTACLES ON SITE SHALL BE FREE OF HOLES, CRACKS, GAPS, AND/OR OTHER PERMEABLE AREAS THAT MAY ALLOW FOR THE DISCHARGE OF POLLUTANTS.
- ALL TRASH RECEPTACLES ON SITE SHALL BE EMPTIED AT A FREQUENCY AS TO ENSURE THAT THE TRASH REMAINS CONFINED TO THE RECEPTACLE.
- ALL LOOSE TRASH AND LITTER ASSOCIATED WITH THE PROJECT MUST BE REMOVED AND PROPERLY DISCARDED ON A DAILY BASIS.
- ALL PORTABLE TOILETS SHALL BE STAKED DOWN AT ALL TIMES USING U-SHAPED REBAR STAKES. THE PORTABLE TOILETS SHALL ALSO BE PLACED A MINIMUM DISTANCE OF 10 FEET FROM ALL IMPERVIOUS SURFACES, INCLUDING, BUT NOT LIMITED TO STREETS CURBS, GUTTERS, SIDEWALKS AND PARKING LOTS.
- THE EROSION CONTROL SUPERVISOR SHALL MAINTAIN STRICT ADHERENCE TO THE LIMITS OF CONSTRUCTION AND PROPERTY LIMITS FOR ALL MATERIALS, VEHICLES AND EQUIPMENT. FAILURE TO ABIDE BY THIS REQUIREMENT MAY RESULT IN THE ISSUANCE OF A STOP WORK ORDER.
- ALL CONSTRUCTION TRAFFIC MUST ENTER AND EXIT THE SITE THROUGH THE APPROVED ACCESS POINT(S). A VEHICLE TRACKING CONTROL PAD IS REQUIRED AT ALL APPROVED ACCESS POINTS TO THE SITE. EXCEPTIONS MAY BE CONSIDERED FOR CONSTRUCTION ACTIVITY OCCURRING IMMEDIATELY ADJACENT TO PAVED AREAS AND WHERE ALTERNATIVE BMPs ARE IMPLEMENTED. SUCH ACTIVITY MAY INCLUDE, BUT NOT BE LIMITED TO RESIDENTIAL CONSTRUCTION, UTILITY CONSTRUCTION, ETC.
- NO PERMANENT SLOPES GREATER THAN 3:1 ARE ALLOWED.
- ALL PERMANENT SLOPES STEEPER THAN 4:1 (HORIZONTAL TO VERTICAL) SHALL REQUIRE EROSION CONTROL BLANKET(S). TEMPORARY SLOPES IN TEMPORARY SEDIMENT BASINS THAT ARE STEEPER THAN 4:1 MAY REQUIRE EROSION CONTROL BLANKETS.
- THE EROSION CONTROL SUPERVISOR SHALL BE RESPONSIBLE FOR CORRECTING ANY ADVERSE IMPACTS THAT OCCUR TO NEIGHBORING PROPERTIES. THE EROSION CONTROL SUPERVISOR MUST OBTAIN PERMISSION FROM LAND OWNERS PRIOR TO ENTERING SUCH PROPERTY.
- A WATER SOURCE SHALL BE AVAILABLE ONSITE DURING CONSTRUCTION ACTIVITIES, AND UTILIZED TO MINIMIZE FUGITIVE DUST. ALTERNATIVE BMPs MAY BE REQUIRED IF INITIAL ATTEMPTS TO SUPPRESS DUST ARE UNSUCCESSFUL.

**CBMP** CONSTRUCTION BEST MANAGEMENT PRACTICES  
**GEN NOTES** 2 OF 4 Oct. 2013

NO CHANGES ARE TO BE MADE TO THIS DRAWING WITHOUT WRITTEN PERMISSION OF THE TOWN OF PARKER.

- ALL CHEMICAL OR HAZARDOUS MATERIAL SPILLS, INCLUDING CONCRETE WASHOUT WATER, WHICH MAY ENTER WATERS OF THE STATE OF COLORADO, WHICH INCLUDES BUT ARE NOT LIMITED TO, SURFACE WATER, GROUND WATER, DRY GULLIES OR STORM SEWERS LEADING TO SURFACE WATER, SHALL BE IMMEDIATELY REPORTED TO THE COLORADO DEPARTMENT OF PUBLIC HEALTH AND ENVIRONMENT (CDPHE) PER 25-8-601, AND THE TOWN OF PARKER. RELEASES OF PETROLEUM PRODUCTS AND CERTAIN HAZARDOUS SUBSTANCES LISTED UNDER THE FEDERAL CLEAN WATER ACT (40 CFR PART 116) MUST BE REPORTED TO THE NATIONAL RESPONSE CENTER AND THE CDPHE. SPILLS THAT POSE AN IMMEDIATE SAFETY HAZARD SHALL BE REPORTED TO 911.
- THE CLEANING OF CONCRETE TRUCKS AND EQUIPMENT IS RESTRICTED TO THE APPROVED CONCRETE WASHOUT LOCATION ON THE JOB SITE. CONCRETE WASH WATER SHALL NOT BE DISCHARGED TO STATE WATERS OR STORM SEWER SYSTEMS.
- VEHICLE AND EQUIPMENT DEGREASING IS PROHIBITED ON THE JOB SITE.
- ALL DEWATERING ON SITE SHALL BE COORDINATED WITH THE TOWN'S INSPECTOR. A STATE PERMIT MAY BE REQUIRED FOR DEWATERING. THE EROSION CONTROL SUPERVISOR IS RESPONSIBLE FOR OBTAINING AND ADHERING TO ALL APPLICABLE PERMITS.
- HYDRAULIC SEEDING AND/OR HYDRAULIC MULCHING ARE ONLY ALLOWED IN AREAS UNDER TEMPORARY OR PERMANENT IRRIGATION OR FOR THE PURPOSE OF TEMPORARY SOIL STABILIZATION.
- APPLICABLE CONSTRUCTION BMPs SHALL REMAIN IN PLACE AND PROPERLY MAINTAINED UNTIL ALL LANDSCAPING HAS BEEN INSTALLED AND THE DESIRABLE VEGETATION HAS REACHED A POINT IN WHICH EROSION AND SEDIMENTATION IS NO LONGER A CONCERN AS DETERMINED BY THE TOWN'S INSPECTOR.
- GRADING SECURITY RELEASE REQUIREMENTS:
  - DEVELOPABLE PROPERTY: IN ORDER FOR THE GRADING SECURITY TO BE RELEASED, THE SITE MUST MEET ITEMS A-H OR ITEM I (BELOW).
    - ALL SOIL-DISTURBING ACTIVITIES ASSOCIATED WITH THE GRADING PERMIT HAVE PERMANENTLY CEASED.
    - UNIFORM PERENNIAL VEGETATION COVER HAS BEEN ESTABLISHED WITH AN INDIVIDUAL PLANT DENSITY OF AT LEAST SEVENTY PERCENT (70%) OF PRE-DISTURBANCE LEVELS.
    - ALL CBMPs HAVE BEEN PROPERLY REMOVED FROM THE SITE.
    - IF ANY EROSION IS PRESENT, IT IS INSIGNIFICANT AND IS NOT LEAVING THE SITE AND/OR LEADING INTO ANY ON-SITE DRAINAGE INFRASTRUCTURE THAT MAY CONVEY SURFACE WATER OFF SITE.
    - WEEDS REPRESENT NO MORE THAN FIFTY PERCENT (50%) OF THE TOTAL VEGETATION ON THE SITE.
    - NO WEEDS ARE PRESENT FROM LIST A OF THE COLORADO NOXIOUS WEED LIST, AS AMENDED.
    - THE SITE IS PREDOMINANTLY FREE OF WEEDS FROM LIST B OF THE COLORADO NOXIOUS WEED LIST, AS AMENDED.
    - WEEDS ARE EVENLY DISTRIBUTED THROUGHOUT THE SITE WITH NO LARGE CONCENTRATIONS PRESENT.
    - A NEW GRADING PERMIT AND REPLACEMENT SECURITY HAS BEEN SUBMITTED AND APPROVED FOR THE APPLICABLE SITE OR ASSIGNMENT AS PROVIDED BY SECTION 11.10.150 OF THE TOWN OF PARKER MUNICIPAL CODE. IT IS THE PROPERTY OWNER'S OBLIGATION AT THE TIME OF CLOSING TO ENSURE THAT THE NEW SITE OWNER HAS PROVIDED THE TOWN WITH A REPLACEMENT SECURITY.

**CBMP** CONSTRUCTION BEST MANAGEMENT PRACTICES  
**GEN NOTES** 3 OF 4 Oct. 2013

NO CHANGES ARE TO BE MADE TO THIS DRAWING WITHOUT WRITTEN PERMISSION OF THE TOWN OF PARKER.

- NONDEVELOPABLE PROPERTY: IN ORDER FOR THE GRADING SECURITY TO BE RELEASED, THE SITE MUST MEET ITEMS A-H AND J, OR ITEMS I AND J (BELOW).
  - ALL SOIL-DISTURBING ACTIVITIES ASSOCIATED WITH THE GRADING PERMIT HAVE PERMANENTLY CEASED.
  - ALL CBMPs HAVE BEEN PROPERLY REMOVED FROM THE SITE.
  - EROSION IS NEGLIGIBLE, IF EVEN PRESENT.
  - THE VEGETATION REPRESENTS A PERENNIAL STAND OF A DENSE, UNIFORM SURFACE OF GRASS WITH NO AREA GREATER THAN ONE (1) SQUARE FOOT THAT IS BARREN OF DESIRABLE VEGETATION. INFREQUENT, WIDELY SCATTERED AREAS WHERE NATIVE VEGETATION HAS NOT YET TAKEN HOLD MAY QUALIFY FOR ACCEPTANCE AT THE DISCRETION OF THE TOWN.
  - WEEDS REPRESENT NO MORE THAN TEN PERCENT (10%) OF THE TOTAL VEGETATION ON SITE.
  - NO WEEDS ARE PRESENT FROM LIST A OF THE COLORADO NOXIOUS WEED LIST, AS AMENDED.
  - THE SITE IS PREDOMINANTLY FREE OF WEEDS FROM LIST B OF THE COLORADO NOXIOUS WEED LIST, AS AMENDED.
  - WEEDS ARE EVENLY DISTRIBUTED THROUGHOUT THE SITE WITH NO LARGE CONCENTRATIONS PRESENT.
  - A NEW GRADING PERMIT AND REPLACEMENT SECURITY HAS BEEN SUBMITTED AND APPROVED FOR THE APPLICABLE SITE OR THE GRADING PERMIT HAS BEEN ASSIGNED AS PROVIDED BY SECTION 11.10.150 OF THE TOWN OF PARKER MUNICIPAL CODE. IT IS THE PROPERTY OWNER'S OBLIGATION, AT THE TIME OF CLOSING ON THE SALE OF A SITE THAT IS SUBJECT TO A GRADING PERMIT, TO ENSURE THAT THE NEW PROPERTY OWNER HAS PROVIDED THE TOWN WITH A REPLACEMENT SECURITY.
  - ALL KNOWN DRAINAGE ISSUES ASSOCIATED WITH THE PROJECT HAVE BEEN MITIGATED AND A SUFFICIENT AMOUNT OF TIME HAS PASSED TO ENSURE THAT SUCH ISSUES HAVE BEEN CORRECTED. THIS REQUIREMENT DOES NOT INCLUDE THOSE DRAINAGE ISSUES ORIGINATING ON RESIDENTIAL LOTS.
  - NOXIOUS WEEDS MUST BE CONTROLLED AS PROVIDED UNDER STATE LAW AND SECTION 6.01.260 OF THE TOWN OF PARKER MUNICIPAL CODE. FAILURE TO CONTROL NOXIOUS WEEDS ON THE SITE MAY CONSTITUTE A NUISANCE, SUBJECT TO THE PENALTIES CONTAINED IN THE CODE.
- DEFINITIONS:**  
 DEVELOPABLE PROPERTY MEANS ANY LAND THAT HAS BEEN GRADED AND IS PART OF A PLATTED LOT OR PLATTED TRACT OF RECORD, THAT WAS PLATTED FOR FUTURE DEVELOPMENT, INCLUDING RESIDENTIAL HOME CONSTRUCTION OR PUBLIC IMPROVEMENTS.  
 NONDEVELOPABLE PROPERTY MEANS LAND THAT HAS BEEN GRADED AND WILL NOT BE FURTHER DISTURBED AS PART OF ANY FUTURE DEVELOPMENT. EXAMPLES INCLUDE, BUT ARE NOT LIMITED TO: PARKS, OPEN SPACE, HOMEOWNER ASSOCIATION OR BUSINESS ASSOCIATION PLATTED TRACTS, DETENTION PONDS AND DRAINAGEWAYS.
- FAILURE TO COMPLY WITH ANY OF THE REQUIREMENTS DESCRIBED IN THIS SECTION MAY RESULT IN THE ISSUANCE OF: A NOTICE OF INTENT TO ISSUE A STOP WORK ORDER, A STOP WORK ORDER AND/OR THE REMEDIES/PENALTIES DESCRIBED IN CHAPTER 11.10 OF THE TOWN OF PARKER MUNICIPAL CODE.
- ANY PERSON CONVICTED OF VIOLATING ANY PROVISION OF THE TOWN OF PARKER, GRADING & EARTH MOVEMENT SECTION OF THE MUNICIPAL CODE SHALL BE GUILTY OF A MISDEMEANOR AND, UPON CONVICTION, BE PUNISHED BY A FINE OF NOT MORE THAN FOUR HUNDRED NINETY NINE DOLLARS (\$499.00) FOR EACH SEPARATE OFFENSE. EACH DAY A VIOLATION CONTINUES SHALL CONSTITUTE A SEPARATE OFFENSE. THE TOWN ALSO MAY SEEK IN MUNICIPAL COURT AN INJUNCTION, ABATEMENT, RESTITUTION OR ANY OTHER REMEDY TO PREVENT, ENJOIN, ABATE OR REMOVE THE VIOLATION. A PERSON CONVICTED OF VIOLATING CHAPTER 11.10 OF THE TOWN OF PARKER MUNICIPAL CODE SHALL BE LIABLE FOR THE ACTUAL COST OF REHABILITATING THE PROPERTY. THE COSTS MAY BE RECOVERED AS RESTITUTION IN MUNICIPAL COURT PROCEEDINGS OR IN A SEPARATE CIVIL ACTION.
- THE TOWN OF PARKER RESERVES THE RIGHT TO ALLOW MODIFICATIONS AND SUBSTITUTIONS TO THE CBMP NOTES AND DETAILS WHEN SUCH MODIFICATIONS AND SUBSTITUTIONS OFFER THE SAME LEVEL OF PROTECTION AS THE STANDARD REQUIREMENTS BASED UPON THE SPECIFIC SITUATION, AS DETERMINED BY TOWN STAFF. DUE TO THE INSIGNIFICANCE AND REGULARITY OF SUCH MODIFICATIONS AND SUBSTITUTIONS, THE APPROVAL OF SUCH VARIATIONS MAY NOT BE DOCUMENTED BY TOWN STAFF.

**CBMP** CONSTRUCTION BEST MANAGEMENT PRACTICES  
**GEN NOTES** 4 OF 4 Oct. 2013

NO CHANGES ARE TO BE MADE TO THIS DRAWING WITHOUT WRITTEN PERMISSION OF THE TOWN OF PARKER.

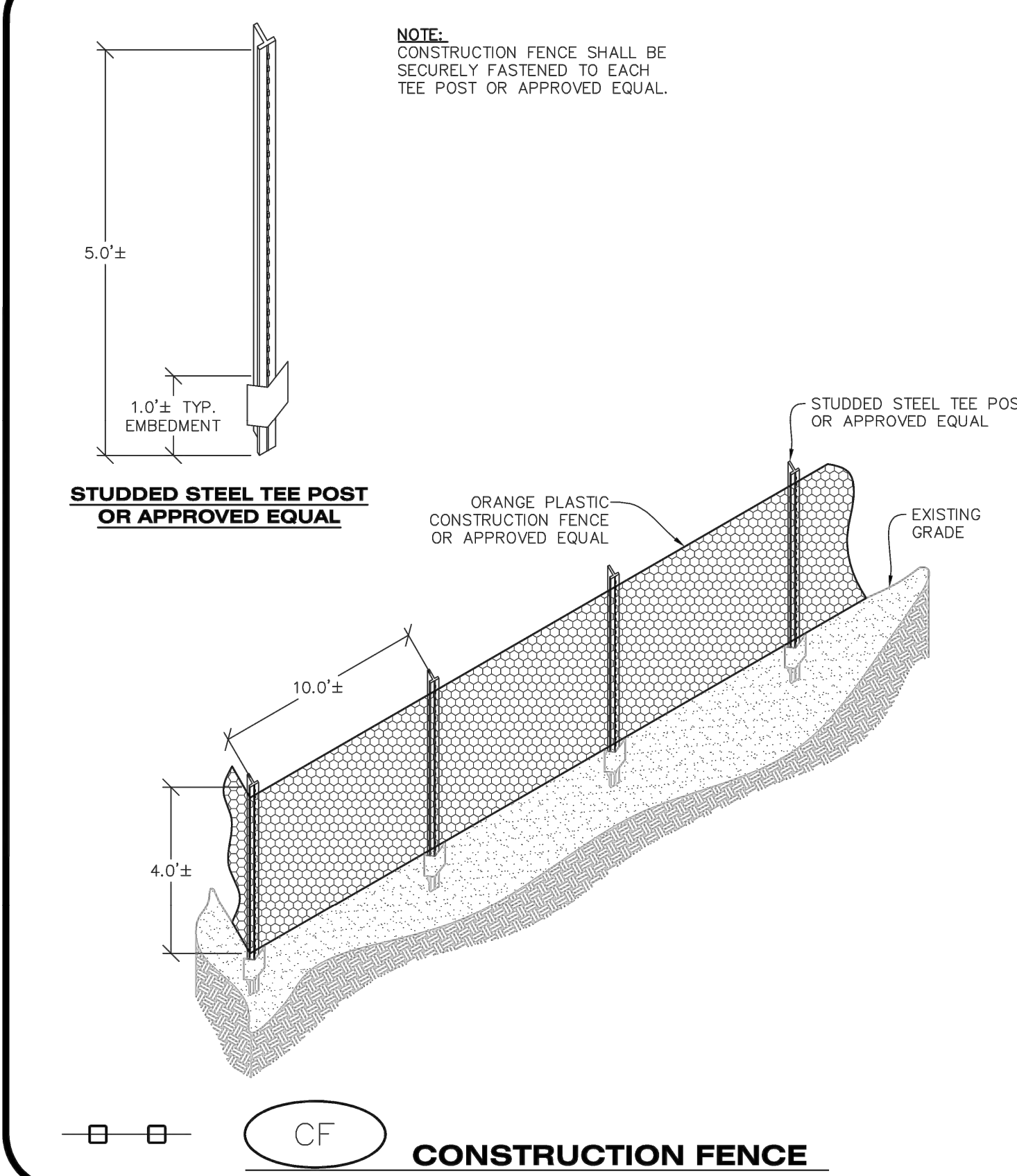

**CBMP** CONSTRUCTION BEST MANAGEMENT PRACTICES  
**CF** 1 OF 2 Oct. 2013

NO CHANGES ARE TO BE MADE TO THIS DRAWING WITHOUT WRITTEN PERMISSION OF THE TOWN OF PARKER.

- CONSTRUCTION FENCE INSTALLATION NOTES**
- THE CONSTRUCTION FENCE SHALL BE SECURELY FASTENED TO EACH POST OR APPROVED EQUAL.
- CONSTRUCTION FENCE INSPECTION AND MAINTENANCE NOTES**
- THE EROSION CONTROL SUPERVISOR SHALL REGULARLY INSPECT THE CONSTRUCTION FENCE AND MAKE ANY NECESSARY REPAIRS.
  - CONSTRUCTION FENCE SHALL BE REPAIRED WHEN THE FENCING MATERIAL FALLS OUT OF COMPLIANCE WITH THE NOTES AND DETAILS.

**CBMP** CONSTRUCTION BEST MANAGEMENT PRACTICES  
**CF** 2 OF 2 Oct. 2013



**CONSULTANTS:**

**Matrix**  
 2435 RESEARCH PARKWAY, SUITE 300  
 COLORADO SPRINGS, CO 80920  
 PHONE: (719) 575-0100  
 FAX: (719) 575-0208

**LAND DEVELOPMENT**  
 CONSULTANTS, LLC  
 950 S. CHERRY STREET, SUITE 512  
 DENVER, CO 80246

**OWNER/DEVELOPER:**

**CIRCLE K**

ROCKY MOUNTAINS DIVISION  
 5500 S QUEBEC STREET, SUITE 100  
 GREENWOOD VILLAGE, CO 80111

**SEAL**

FOR AND ON BEHALF OF MATRIX DESIGN GROUP, INC. CONTRACTOR IS RESPONSIBLE FOR OBTAINING THE MOST RECENT PROJECT CONSTRUCTION DOCUMENTS. MATRIX DESIGN GROUP IS NOT RESPONSIBLE FOR CHANGES, ALTERATIONS, OR USE OF CONSTRUCTION DOCUMENTS PRIOR TO JURISDICTIONAL APPROVAL.

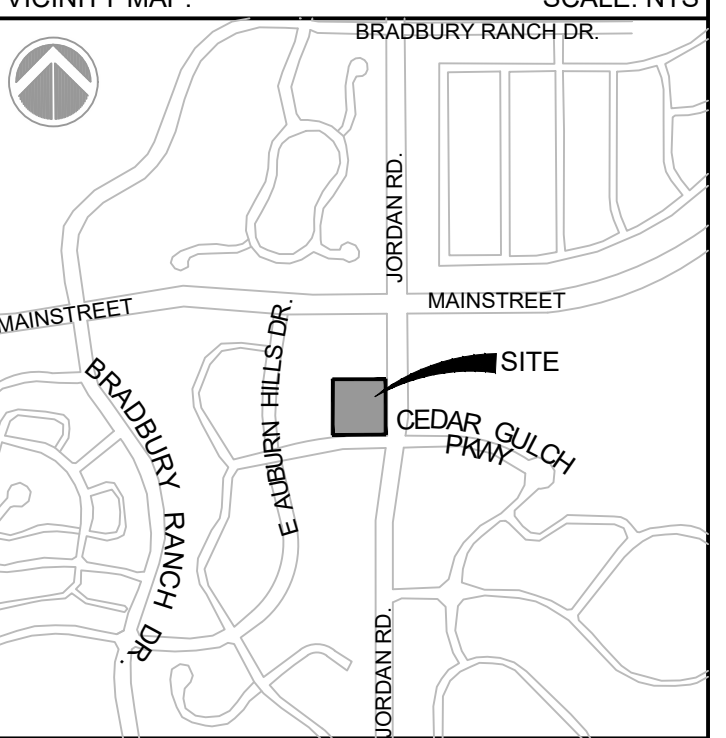

**PROJECT:**

**CIRCLE K**

**CONSTRUCTION DOCUMENTS**

16846 E AUBURN HILLS DRIVE  
 PARKER, CO 80134

**REVISION HISTORY:**

NO.	DATE	DESCRIPTION	BY

**DRAWING INFORMATION:**

PROJECT NO: 21.1207.030  
 DRAWN BY: RAD  
 CHECKED BY: NMS  
 DESIGNED BY: NMS

**CBMP DETAILS**

**C4.3**

**SHEET 12 OF 26**

DATE: NOVEMBER 2022

FILE LOCATION: S:\CIRCLE K\MAIN & JORDAN\100 DIVISION PLAN SETS\CONSTRUCTION PLANS\CBMP.DWG



Know what's below.  
Call before you dig.



2435 RESEARCH PARKWAY, SUITE 300  
COLORADO SPRINGS, CO 80920  
PHONE: (719) 575-0100  
FAX: (719) 575-0208



LAND DEVELOPMENT  
CONSULTANTS, LLC

950 S. CHERRY STREET, SUITE 512  
DENVER, CO 80246

OWNER/DEVELOPER:



ROCKY MOUNTAINS DIVISION  
5500 S QUEBEC STREET, SUITE 100  
GREENWOOD VILLAGE, CO 80111

SEAL



FOR AND ON BEHALF OF MATRIX DESIGN GROUP, INC  
CONTRACTOR IS RESPONSIBLE FOR OBTAINING THE  
MOST RECENT PROJECT CONSTRUCTION DOCUMENTS.  
MATRIX DESIGN GROUP IS NOT RESPONSIBLE FOR  
CHANGES, ALTERATIONS, OR USE OF CONSTRUCTION  
DOCUMENTS PRIOR TO JURISDICTIONAL APPROVAL.

VICINITY MAP: SCALE: NTS

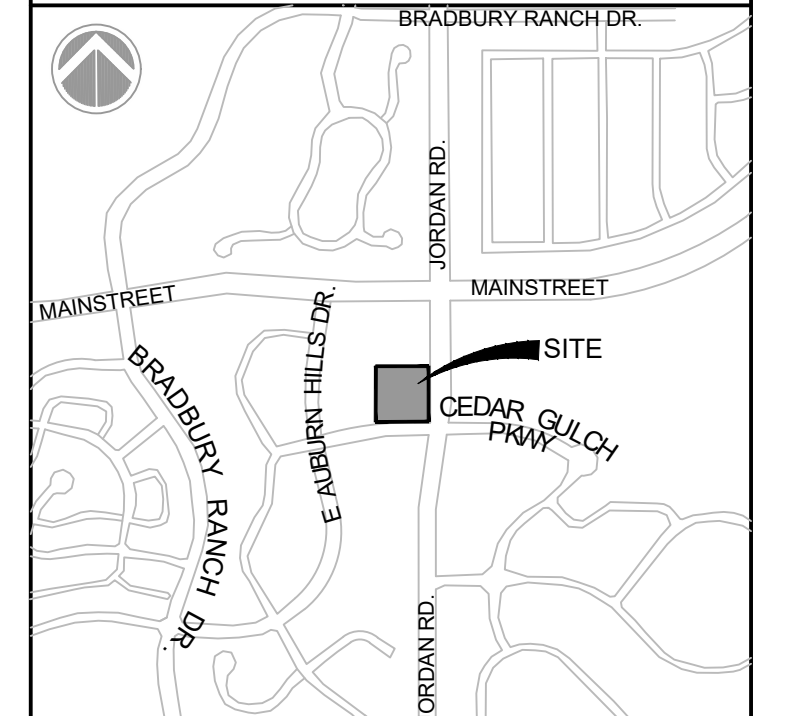

PROJECT:

CIRCLE K

CONSTRUCTION DOCUMENTS

16846 E AUBURN HILLS DRIVE  
PARKER, CO 80134

REVISION HISTORY:

NO.	DATE	DESCRIPTION	BY

DRAWING INFORMATION:

PROJECT NO: 21.1207.030

DRAWN BY: RAD

CHECKED BY: NMS

DESIGNED BY: NMS

SHEET TITLE:

CBMP DETAILS

C4.4

SHEET 13 OF 26

DATE: NOVEMBER 2022

CONSULTANTS:

NO CHANGES ARE TO BE MADE TO THIS DRAWING WITHOUT WRITTEN PERMISSION OF THE TOWN OF PARKER.

### CHECK DAM INSTALLATION NOTES

- SEE PLAN VIEW FOR LOCATION(S) OF CHECK DAMS.
- CHECK DAMS SHOWN ON CBMP PLAN SHALL BE INSTALLED WHEN DIRECTED BY THE TOWN'S INSPECTOR.
- RIPRAP UTILIZED FOR CHECK DAMS SHALL HAVE A D50 MEDIAN STONE SIZE OF 12".
- RIPRAP PAD SHALL BE TRENCHED INTO THE GROUND A MINIMUM OF 1'-8".
- THE MAXIMUM SPACING BETWEEN CHECK DAMS SHOULD BE SUCH THAT THE BOTTOM OF THE UPSTREAM DAM IS AT THE SAME ELEVATION AS THE TOP OF THE DOWNSTREAM DAM AS SHOWN IN THE DETAIL.

### CHECK DAM INSPECTION AND MAINTENANCE NOTES

- THE EROSION CONTROL SUPERVISOR SHALL REGULARLY INSPECT THE CHECK DAMS.
- ACCUMULATED SEDIMENT SHALL BE REMOVED ONCE SEDIMENT HAS REACHED A DEPTH EQUAL TO 1/2 THE HEIGHT OF THE CREST OR AS OTHERWISE DIRECTED BY THE TOWN'S INSPECTOR.
- CHECK DAMS SHALL REMAIN IN PLACE AND PROPERLY MAINTAINED UNTIL VEGETATIVE COVER HAS REACHED A CONSISTENT DENSITY OF AT LEAST 70% OF FULL VEGETATIVE COVER AND EROSION AND SEDIMENTATION IS NO LONGER A POSSIBILITY AS DETERMINED BY THE TOWN'S INSPECTOR OR AS OTHERWISE DIRECTED BY THE TOWN'S INSPECTOR.
- WHEN CHECK DAMS ARE REMOVED, THE TOWN'S INSPECTOR MAY REQUIRE EXCAVATIONS TO BE FILLED WITH SUITABLE COMPACTED TOPSOIL AND ANY DISTURBED AREAS ASSOCIATED WITH THE INSTALLATION, MAINTENANCE, AND/OR REMOVAL OF THE CHECK DAMS BE ROUGHENED, SEEDED, MULCHED, AND CRIMPED PER THE TOWN'S SPECIFICATIONS (SEE DETAIL SMC).
- IN SOME INSTANCES, CHECK DAMS MAY REMAIN IN PLACE PERMANENTLY.

Town of Parker COLORADO  
CONSTRUCTION BEST MANAGEMENT PRACTICES  
CD 3 OF 3  
Oct. 2013

NO CHANGES ARE TO BE MADE TO THIS DRAWING WITHOUT WRITTEN PERMISSION OF THE TOWN OF PARKER.

### SECTION B

UPSTREAM AND DOWNSTREAM CHANNEL SECTION

1.5' MIN. CREST LENGTH

1'-8" MIN. EMBANKMENT (EXISTING)

### SECTION C

3.0' MIN. SPACING

1'-8" MIN. EMBANKMENT (EXISTING)

NOTE: SECTION C IS LOCATED IMMEDIATELY UPSTREAM AND DOWNSTREAM OF THE CHECK DAM. THEREFORE NO ROCK IS SHOWN WITHIN THE CHANNEL FLOW AREA.

L = THE DISTANCE SUCH THAT POINT A AND B ARE OF EQUAL ELEVATION.

### SPACING BETWEEN CHECK DAMS

Town of Parker COLORADO  
CONSTRUCTION BEST MANAGEMENT PRACTICES  
CD 2 OF 3  
Oct. 2013

NO CHANGES ARE TO BE MADE TO THIS DRAWING WITHOUT WRITTEN PERMISSION OF THE TOWN OF PARKER.

### PLAN VIEW

CHECK DAM

### SECTION A

RIPRAP TYPE M  
D<sub>50</sub>=12" (MIN)

1.5' MIN. RIPRAP SHALL BE EMBEDDED 1'-8" MIN.

Town of Parker COLORADO  
CONSTRUCTION BEST MANAGEMENT PRACTICES  
CD 1 OF 3  
Oct. 2013

NO CHANGES ARE TO BE MADE TO THIS DRAWING WITHOUT WRITTEN PERMISSION OF THE TOWN OF PARKER.

### EROSION CONTROL BLANKET INSTALLATION NOTES

- SEE THE PLAN VIEW FOR THE LOCATION(S) OF THE EROSION CONTROL BLANKETS.
- EROSION CONTROL BLANKETS USED FOR CHANNEL PROTECTION SHALL BE PROPERLY SELECTED BY THE DESIGN ENGINEER BASED ON CURRENT AND FUTURE FLOW RATES WITHIN THE CHANNEL. BASED ON THESE CALCULATIONS, TURF REINFORCEMENT MATTING OR RIPRAP MAY BE NECESSARY IN LIEU OF EROSION CONTROL BLANKETS.
- IMMEDIATELY PRIOR TO BLANKET INSTALLATION, SOIL SURFACE SHALL BE SMOOTH, AND FREE OF ANY GAPS, VOIDS, WEEDS, ROCKS, STICKS, OR OTHER MISCELLANEOUS DEBRIS.
- EROSION CONTROL BLANKET SHALL THEN BE INSTALLED ACCORDING TO THE DETAILED DRAWINGS.
- ANY DAMAGED OR REMAINING STAPLES OR STAKES SHALL BE REMOVED FROM THE SITE.
- ALL EROSION CONTROL BLANKETS FOR SLOPE PROTECTION INSTALLED IN THE TOWN SHALL BE DOUBLE NET, STRAW OR EXCELSIOR.

MANUFACTURER	PRODUCT NAME
NORTH AMERICAN GREEN	S150
APPROVED EQUAL	APPROVED EQUAL

### EROSION CONTROL BLANKET MAINTENANCE NOTES

- THE EROSION CONTROL SUPERVISOR SHALL REGULARLY INSPECT THE EROSION CONTROL BLANKETS AND MAKE ANY NECESSARY REPAIRS.

Town of Parker COLORADO  
CONSTRUCTION BEST MANAGEMENT PRACTICES  
ECB 3 OF 3  
Oct. 2013

NO CHANGES ARE TO BE MADE TO THIS DRAWING WITHOUT WRITTEN PERMISSION OF THE TOWN OF PARKER.

6" MIN. COMPACTED BACKFILL (TYP.)

6" MIN. JOINT ANCHOR TRENCH USED TO JOIN BLANKETS TOGETHER (LONGITUDINAL)

18" SAW 2" x 4" LUMBER ON DIAGONAL

WOOD STAKE DETAIL  
ALTERNATIVE WOOD STAKE PRODUCTS MAY BE USED WITH APPROVAL FROM THE TOWN.

ROLL WIDTH "W"

1/2 "W"

1/4 "W"

1/2 "W"

NOTES:

- WOOD STAKES SHALL BE INSTALLED SUCH THAT ONLY 1" IS EXPOSED ABOVE THE GROUND.
- WHEN NECESSARY, ALL SEEDING SHALL BE COMPLETED PRIOR TO THE PLACEMENT OF EROSION CONTROL BLANKETS. PLEASE SEE DETAIL SMC FOR SEEDING, MULCHING, AND CRIMPING REQUIREMENTS.

STAPLING PATTERN  
NOTE: STAPLES SHALL BE INSTALLED PER MANUFACTURERS RECOMMENDATION. IF MANUFACTURER INFO IS NOT AVAILABLE THEN ABOVE STAPLING PATTERN SHALL BE USED. STAPLES SHALL NOT BE USED FOR EROSION CONTROL BLANKET IN CHANNELS.

Town of Parker COLORADO  
CONSTRUCTION BEST MANAGEMENT PRACTICES  
ECB 2 OF 3  
Oct. 2013

NO CHANGES ARE TO BE MADE TO THIS DRAWING WITHOUT WRITTEN PERMISSION OF THE TOWN OF PARKER.

START EROSION BLANKET AT THE TOP OF SLOPE AND EXTEND PAST THE TOE OF SLOPE. BLANKET SHALL BE PLACED PERPENDICULAR TO THE TOP AND BOTTOM OF THE SLOPE. COMPLETE SUBSEQUENT ROWS IN THE SAME MANNER, OVERLAPPING THE BLANKETS A MINIMUM OF 1.0'.

1. TOP SLOPE ANCHOR SLOT

2. BLANKET OVERLAPS

3. TOP SIDE SLOPE EDGE OF BLANKET

4. BLANKET TERMINAL ENDS

STAPLE PATTERN  
NOTE: STAPLES SHALL BE INSTALLED PER MANUFACTURERS RECOMMENDATION. IF MANUFACTURER INFO IS NOT AVAILABLE THEN ABOVE STAPLE PATTERN SHALL BE USED. WOODEN STAKES SHALL NOT BE USED FOR EROSION CONTROL BLANKET ON SLOPES.

NOTE:  
WHEN NECESSARY, ALL SEEDING SHALL BE COMPLETED PRIOR TO THE PLACEMENT OF EROSION CONTROL BLANKETS. PLEASE SEE DETAIL SMC FOR SEEDING, MULCHING, AND CRIMPING REQUIREMENTS.

Town of Parker COLORADO  
CONSTRUCTION BEST MANAGEMENT PRACTICES  
ECB 1 OF 3  
Oct. 2013

FILE LOCATION: S:\CIRCLE K\MIAMI & JORDAN\1100 DIVISION 4 PLAN SETS\CONSTRUCTION PLANS\CBMP.DWG

NO CHANGES ARE TO BE MADE TO THIS DRAWING WITHOUT WRITTEN PERMISSION OF THE TOWN OF PARKER.

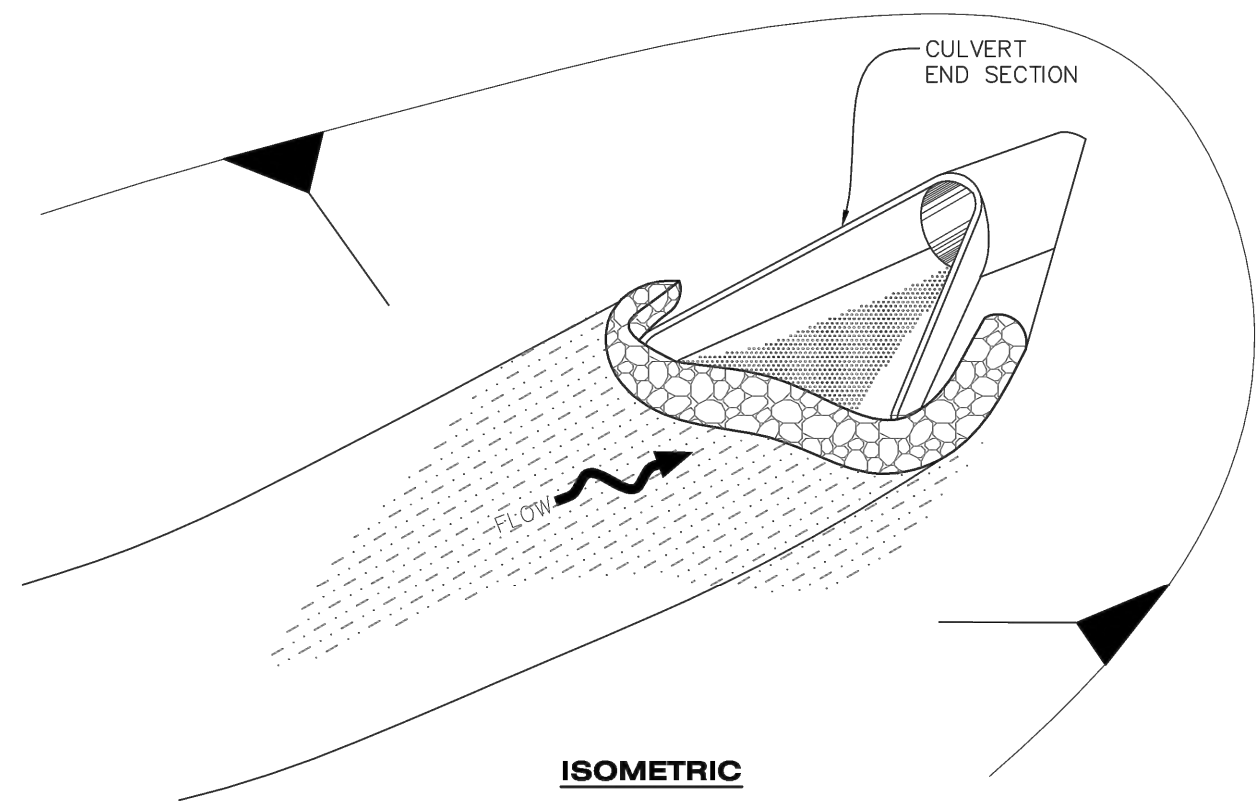
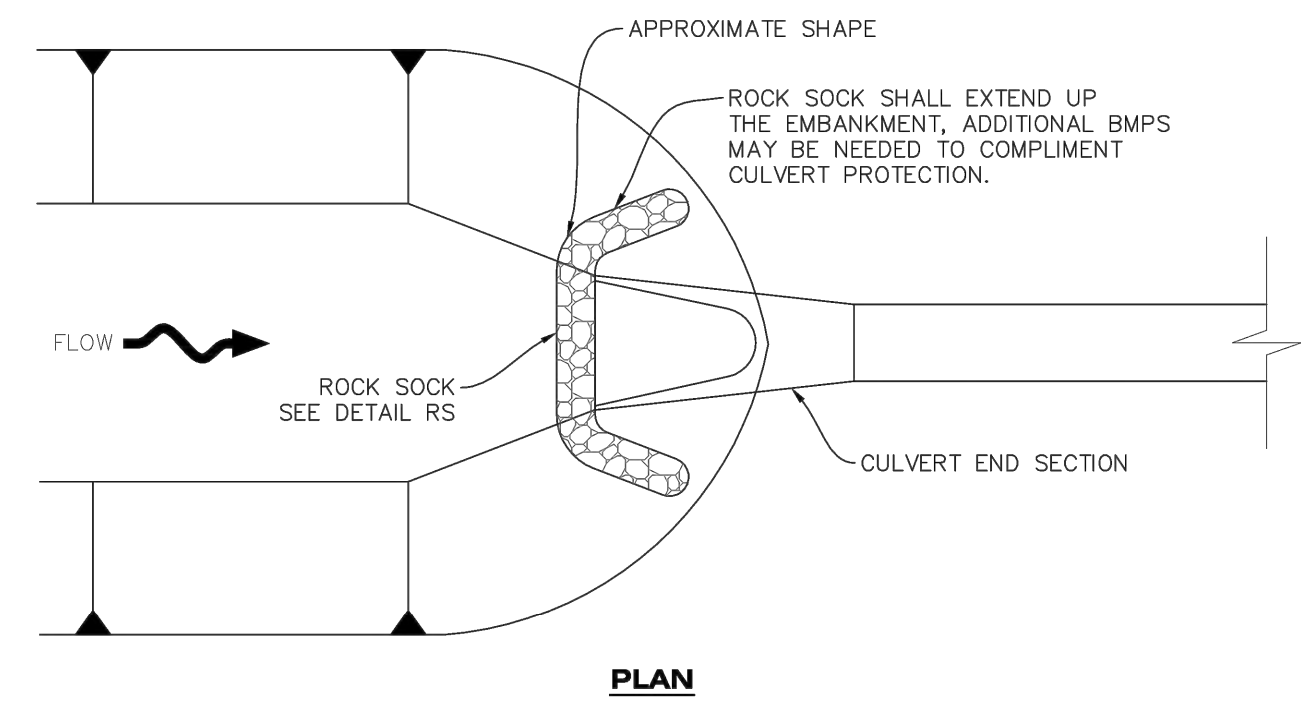

CP

**CULVERT PROTECTION (INLET)**



**CBMP**

CONSTRUCTION BEST MANAGEMENT PRACTICES

CP

1 OF 2

Oct. 2013

NO CHANGES ARE TO BE MADE TO THIS DRAWING WITHOUT WRITTEN PERMISSION OF THE TOWN OF PARKER.

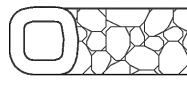
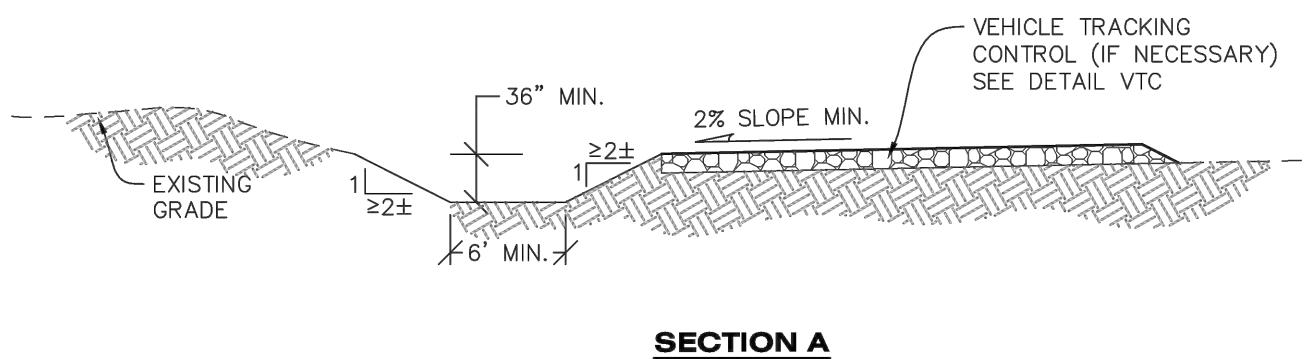
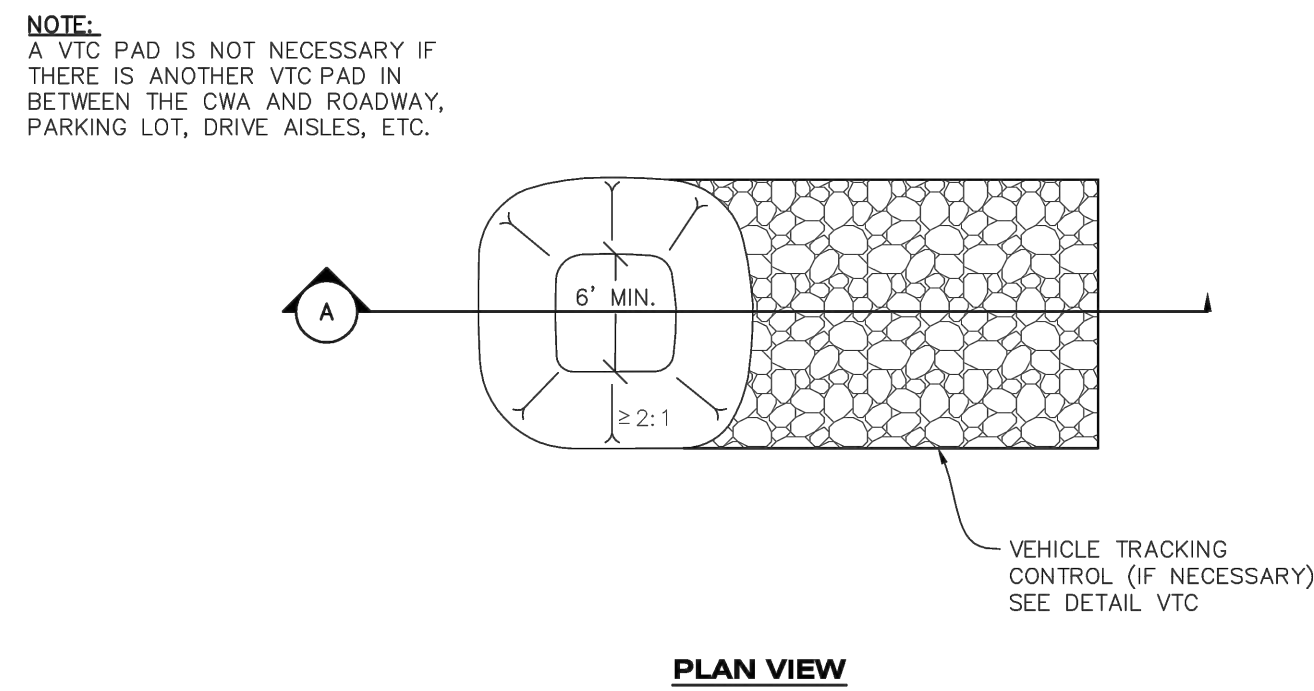

CWA

**CONCRETE WASHOUT AREA**



**CBMP**

CONSTRUCTION BEST MANAGEMENT PRACTICES

CWA

1 OF 2

Oct. 2013

NO CHANGES ARE TO BE MADE TO THIS DRAWING WITHOUT WRITTEN PERMISSION OF THE TOWN OF PARKER.

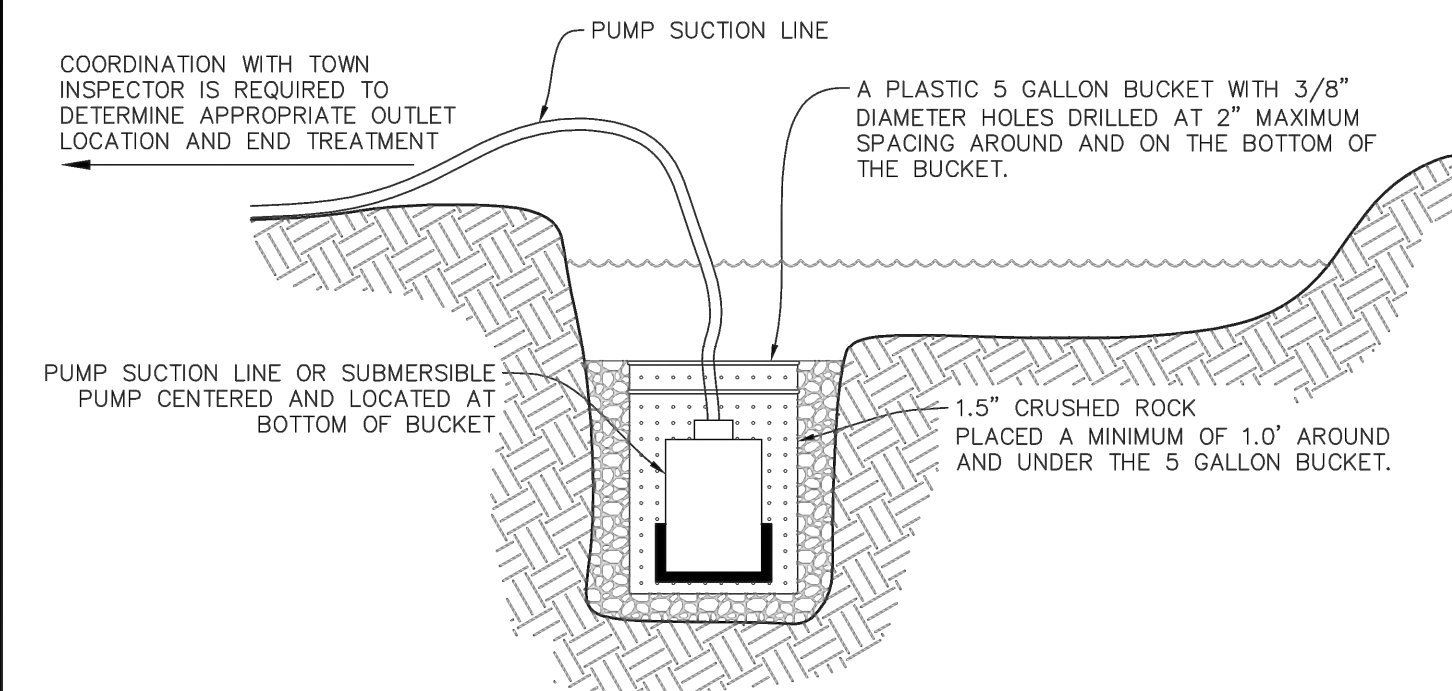

**NOTE:**  
IT IS THE CONTRACTOR'S RESPONSIBILITY TO DETERMINE APPROPRIATE MEASURES TO PROTECT PUMPING EQUIPMENT AND MINIMIZE SEDIMENT. USE OF A PLASTIC 5 GALLON BUCKET IS SUGGESTED BUT NOT REQUIRED. THE CONTRACTOR SHALL NOT HOLD THE TOWN LIABLE FOR DAMAGE TO PUMPING EQUIPMENT REGARDLESS OF METHODS USED.

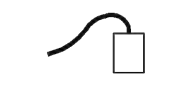

D

**DEWATERING**



**CBMP**

CONSTRUCTION BEST MANAGEMENT PRACTICES

D

1 OF 2

Oct. 2013

NO CHANGES ARE TO BE MADE TO THIS DRAWING WITHOUT WRITTEN PERMISSION OF THE TOWN OF PARKER.

**CULVERT PROTECTION (INLET) INSTALLATION NOTES**

1. SEE PLAN VIEW FOR LOCATION(S) OF CULVERT PROTECTION (INLET).
2. ROCK SOCK SHALL BE CONSTRUCTED ACCORDING TO THE DETAIL (SEE DETAIL RS).
3. ROCK SOCK SHALL BE APPROXIMATELY 12" IN DIAMETER.
4. ROCK SOCK SHALL EXTEND ABOVE THE FLOW LINE ELEVATION ON BOTH SIDES OF THE CULVERT END SECTION.

**CULVERT PROTECTION (INLET) INSPECTION AND MAINTENANCE NOTES**

1. THE EROSION CONTROL SUPERVISOR SHALL REGULARLY INSPECT THE CULVERT PROTECTION (INLET).
2. AT A MINIMUM, ACCUMULATED SEDIMENT SHALL BE REMOVED ONCE SEDIMENT HAS REACHED A DEPTH EQUAL TO 1/2 THE HEIGHT OF THE ROCK SOCK.
3. CULVERT PROTECTION (INLET) IS TO REMAIN IN PLACE AND PROPERLY MAINTAINED UNTIL VEGETATIVE COVER HAS REACHED A CONSISTENT DENSITY OF AT LEAST 70% OF FULL VEGETATIVE COVER AND EROSION AND SEDIMENTATION IS NO LONGER A POSSIBILITY AS DETERMINED BY THE TOWN'S INSPECTOR OR AS OTHERWISE DIRECTED BY THE TOWN'S INSPECTOR.
4. WHEN THE CULVERT INLET PROTECTION IS REMOVED, THE TOWN'S INSPECTOR MAY REQUIRE ANY DISTURBED AREAS ASSOCIATED WITH THE INSTALLATION, MAINTENANCE, AND/OR REMOVAL OF THE CULVERT INLET PROTECTION TO BE ROUGHENED, SEEDED, MULCHED, AND CRIMPED PER THE TOWN'S SPECIFICATIONS (SEE DETAIL SMC).



CP

**CBMP**

CONSTRUCTION BEST MANAGEMENT PRACTICES

CP

2 OF 2

Oct. 2013

NO CHANGES ARE TO BE MADE TO THIS DRAWING WITHOUT WRITTEN PERMISSION OF THE TOWN OF PARKER.

**CONCRETE WASHOUT AREA INSTALLATION NOTES**

1. CONCRETE WASHOUT AREAS SHALL BE INSTALLED PRIOR TO ANY CONCRETE PLACEMENT ON SITE.
2. A VEHICLE TRACKING CONTROL PAD IS REQUIRED AT THE ACCESS POINT TO ALL CONCRETE WASHOUT AREAS WHEN NO OTHER VTC PAD EXISTS IN BETWEEN THE CWA AND THE ROADWAY.
3. IF GROUNDWATER IS ENCOUNTERED WHEN DIGGING THE PIT, A NEW LOCATION SHOULD BE SELECTED. IF NO OTHER LOCATION CAN BE FOUND, A ONE-PIECE IMPERVIOUS LINER SHALL BE REQUIRED ALONG THE BOTTOM AND SIDES OF THE SUBSURFACE PIT.

**CONCRETE WASHOUT AREA INSPECTION AND MAINTENANCE NOTES**

1. THE EROSION CONTROL SUPERVISOR SHALL REGULARLY INSPECT THE CONCRETE WASHOUT AREA.
2. CONCRETE WASHOUT MATERIALS SHALL BE REMOVED BEFORE ITS CAPACITY HAS BEEN REACHED.
3. CONCRETE WASHOUT AREAS SHALL BE ENLARGED AS NECESSARY TO MAINTAIN CAPACITY FOR WASTED CONCRETE AND ASSOCIATED WASH WATER.
4. CONCRETE WASHOUT WATER, WASTED PIECES OF CONCRETE AND ALL OTHER DEBRIS IN THE SUBSURFACE PIT SHALL BE TRANSPORTED FROM THE JOB SITE AS NECESSARY TO ENSURE ADEQUATE CAPACITY.
5. CONCRETE WASHOUT AREAS SHALL REMAIN IN PLACE UNTIL ALL CONCRETE FOR THE PROJECT IS PLACED.
6. WHEN CONCRETE WASHOUT AREAS ARE REMOVED, THE TOWN'S INSPECTOR MAY REQUIRE EXCAVATIONS TO BE FILLED WITH SUITABLE COMPACTED BACKFILL AND TOPSOIL, ANY DISTURBED AREAS ASSOCIATED WITH THE INSTALLATION, MAINTENANCE, AND/OR REMOVAL OF THE CONCRETE WASHOUT AREAS SHALL BE ROUGHENED, SEEDED, MULCHED, AND CRIMPED PER THE TOWN'S SPECIFICATIONS (SEE DETAIL SMC).



CWA

**CBMP**

CONSTRUCTION BEST MANAGEMENT PRACTICES

CWA

2 OF 2

Oct. 2013

NO CHANGES ARE TO BE MADE TO THIS DRAWING WITHOUT WRITTEN PERMISSION OF THE TOWN OF PARKER.

**DEWATERING INSTALLATION NOTES**

1. IT IS THE EROSION CONTROL SUPERVISOR'S RESPONSIBILITY TO ENSURE THAT ALL DEWATERING IS PERFORMED IN ACCORDANCE WITH THE REQUIREMENTS OF THE COLORADO DEPARTMENT OF PUBLIC HEALTH AND ENVIRONMENT (CDPHE).

**DEWATERING MAINTENANCE NOTES**

1. THE EROSION CONTROL SUPERVISOR SHALL INSPECT THE DEWATERING OPERATION TO ENSURE THAT THE DISCHARGE WATER IS DRAINING TO THE PROPER LOCATION(S) AND PERFORM ANY NECESSARY REPAIRS OR MAINTENANCE ON A FREQUENT BASIS.



D

**CBMP**

CONSTRUCTION BEST MANAGEMENT PRACTICES

D

2 OF 2

Oct. 2013



Know what's below. Call before you dig.



2435 RESEARCH PARKWAY, SUITE 300  
COLORADO SPRINGS, CO 80920  
PHONE: (719) 575-0100  
FAX: (719) 575-0208



**LAND DEVELOPMENT**

CONSULTANTS, LLC  
950 S. CHERRY STREET, SUITE 512  
DENVER, CO 80246

OWNER/DEVELOPER:



ROCKY MOUNTAINS DIVISION  
5500 S QUEBEC STREET, SUITE 100  
GREENWOOD VILLAGE, CO 80111

SEAL



FOR AND ON BEHALF OF MATRIX DESIGN GROUP, INC  
CONTRACTOR IS RESPONSIBLE FOR OBTAINING THE MOST RECENT PROJECT CONSTRUCTION DOCUMENTS.  
MATRIX DESIGN GROUP IS NOT RESPONSIBLE FOR CHANGES, ALTERATIONS, OR USE OF CONSTRUCTION DOCUMENTS PRIOR TO JURISDICTIONAL APPROVAL.

VICINITY MAP: SCALE: NTS

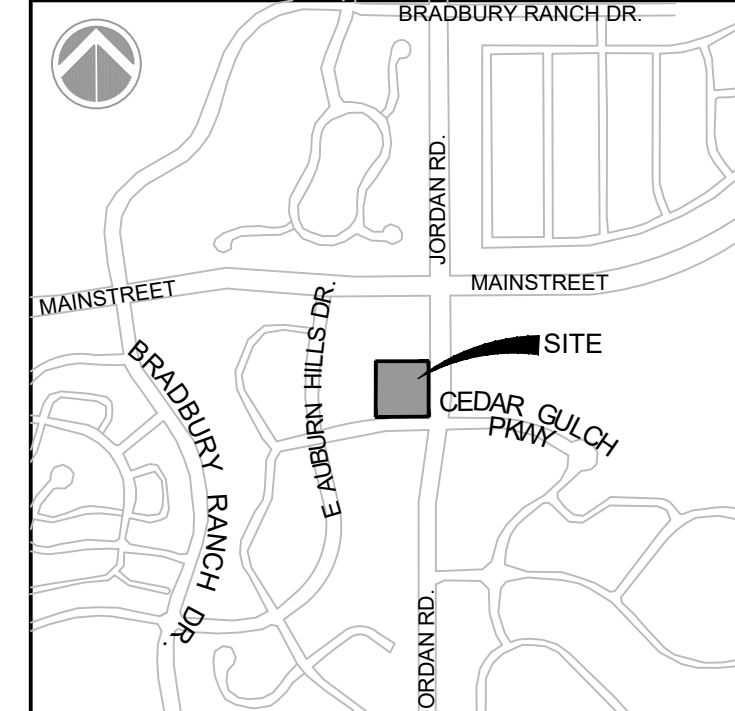

PROJECT:

**CIRCLE K**

**CONSTRUCTION DOCUMENTS**

16846 E AUBURN HILLS DRIVE  
PARKER, CO 80134

REVISION HISTORY:

NO.	DATE	DESCRIPTION	BY

DRAWING INFORMATION:

PROJECT NO: 21.1207.030

DRAWN BY: RAD

CHECKED BY: NMS

DESIGNED BY: NMS

SHEET TITLE:

**CBMP DETAILS**

**C4.5**

SHEET 14 OF 26

DATE: NOVEMBER 2022

FILE LOCATION: S:\CIRCLE K\MIAMI & JORDAN\100 DIVISION 14 PLAN SETS\CONSTRUCTION PLANS\CBMP.DWG



**Matrix**  
 2435 RESEARCH PARKWAY, SUITE 300  
 COLORADO SPRINGS, CO 80920  
 PHONE: (719) 575-0100  
 FAX: (719) 575-0208

**LAND DEVELOPMENT**  
 CONSULTANTS, LLC  
 950 S. CHERRY STREET, SUITE 512  
 DENVER, CO 80246

**CIRCLE K**

ROCKY MOUNTAINS DIVISION  
 5500 S QUEBEC STREET, SUITE 100  
 GREENWOOD VILLAGE, CO 80111

FOR AND ON BEHALF OF MATRIX DESIGN GROUP, INC. CONTRACTOR IS RESPONSIBLE FOR OBTAINING THE MOST RECENT PROJECT CONSTRUCTION DOCUMENTS. MATRIX DESIGN GROUP IS NOT RESPONSIBLE FOR CHANGES, ALTERATIONS, OR USE OF CONSTRUCTION DOCUMENTS PRIOR TO JURISDICTIONAL APPROVAL.

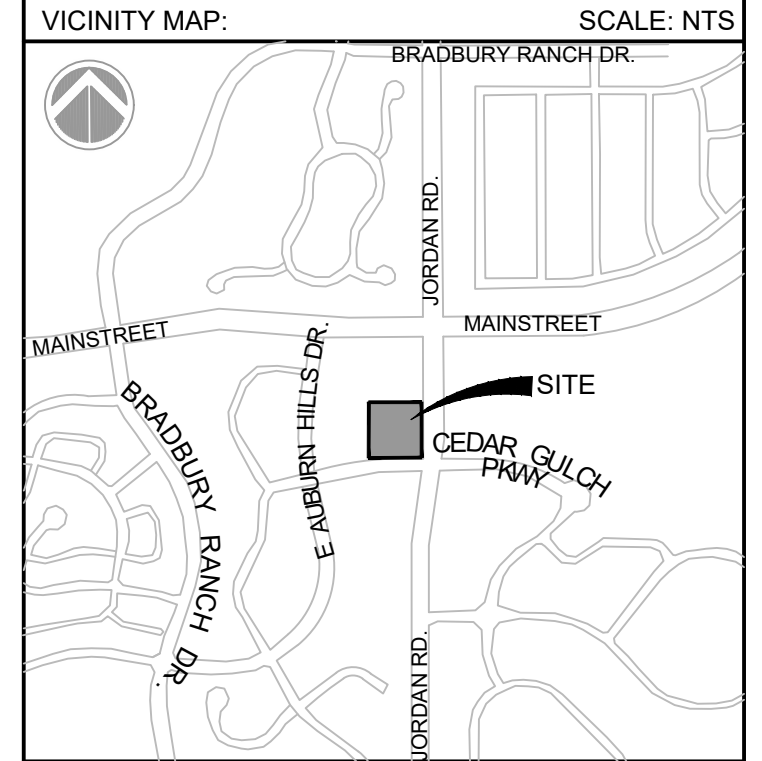

PROJECT:  
**CIRCLE K**  
**CONSTRUCTION DOCUMENTS**  
 16846 E AUBURN HILLS DRIVE  
 PARKER, CO 80134

REVISION HISTORY:

NO.	DATE	DESCRIPTION	BY

DRAWING INFORMATION:  
 PROJECT NO: 21.1207.030  
 DRAWN BY: RAD  
 CHECKED BY: NMS  
 DESIGNED BY: NMS

**CBMP DETAILS**

**C4.6**  
 SHEET 15 OF 26

DATE: NOVEMBER 2022

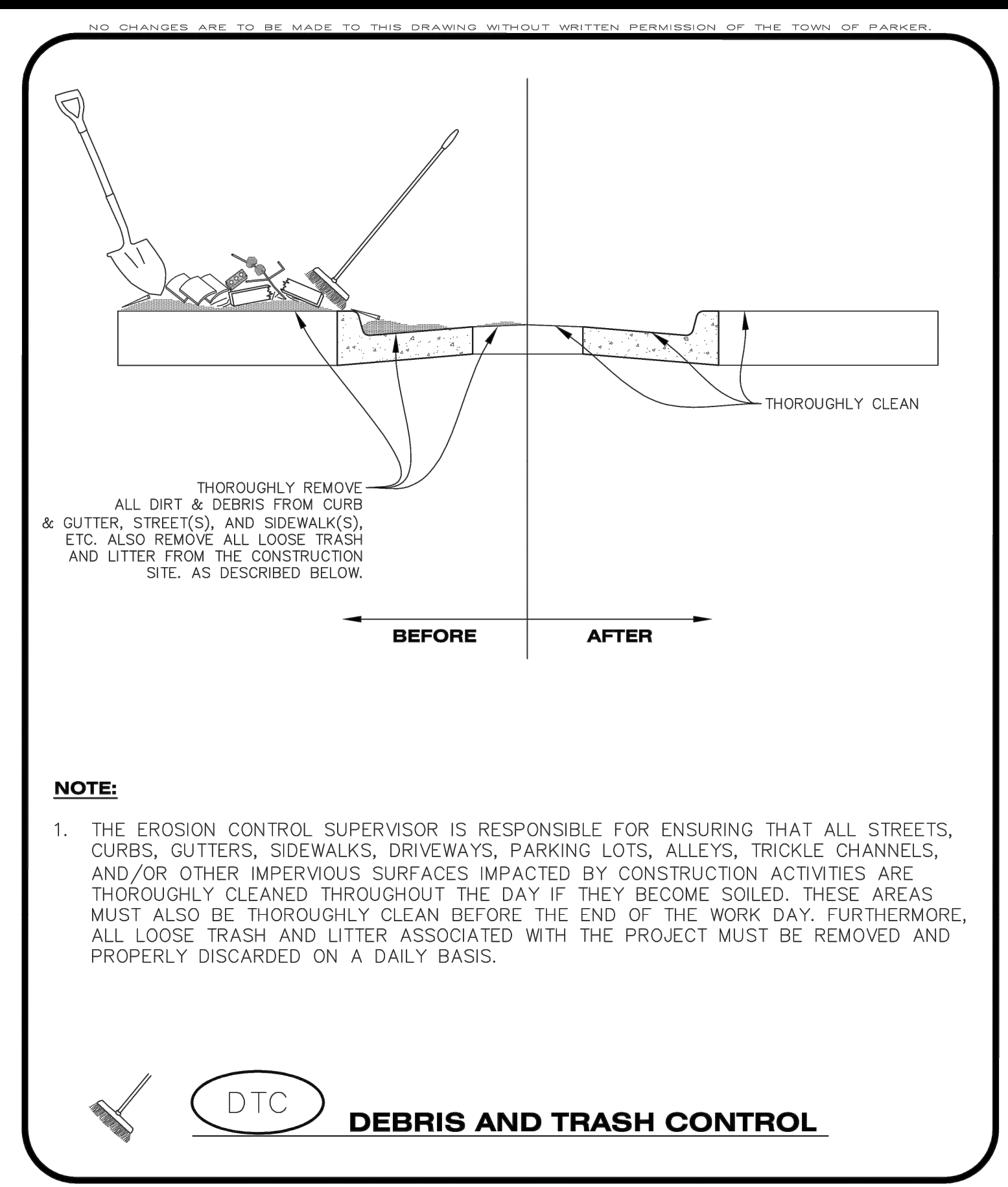

**DTC**  
**DEBRIS AND TRASH CONTROL**

**NOTE:**  
 1. THE EROSION CONTROL SUPERVISOR IS RESPONSIBLE FOR ENSURING THAT ALL STREETS, CURBS, GUTTERS, SIDEWALKS, DRIVEWAYS, PARKING LOTS, ALLEYS, TRICKLE CHANNELS, AND/OR OTHER IMPERVIOUS SURFACES IMPACTED BY CONSTRUCTION ACTIVITIES ARE THOROUGHLY CLEANED THROUGHOUT THE DAY IF THEY BECOME SOILED. THESE AREAS MUST ALSO BE THOROUGHLY CLEAN BEFORE THE END OF THE WORK DAY. FURTHERMORE, ALL LOOSE TRASH AND LITTER ASSOCIATED WITH THE PROJECT MUST BE REMOVED AND PROPERLY DISCARDED ON A DAILY BASIS.

**CBMP** CONSTRUCTION BEST MANAGEMENT PRACTICES **DTC** 1 OF 2 Oct. 2013

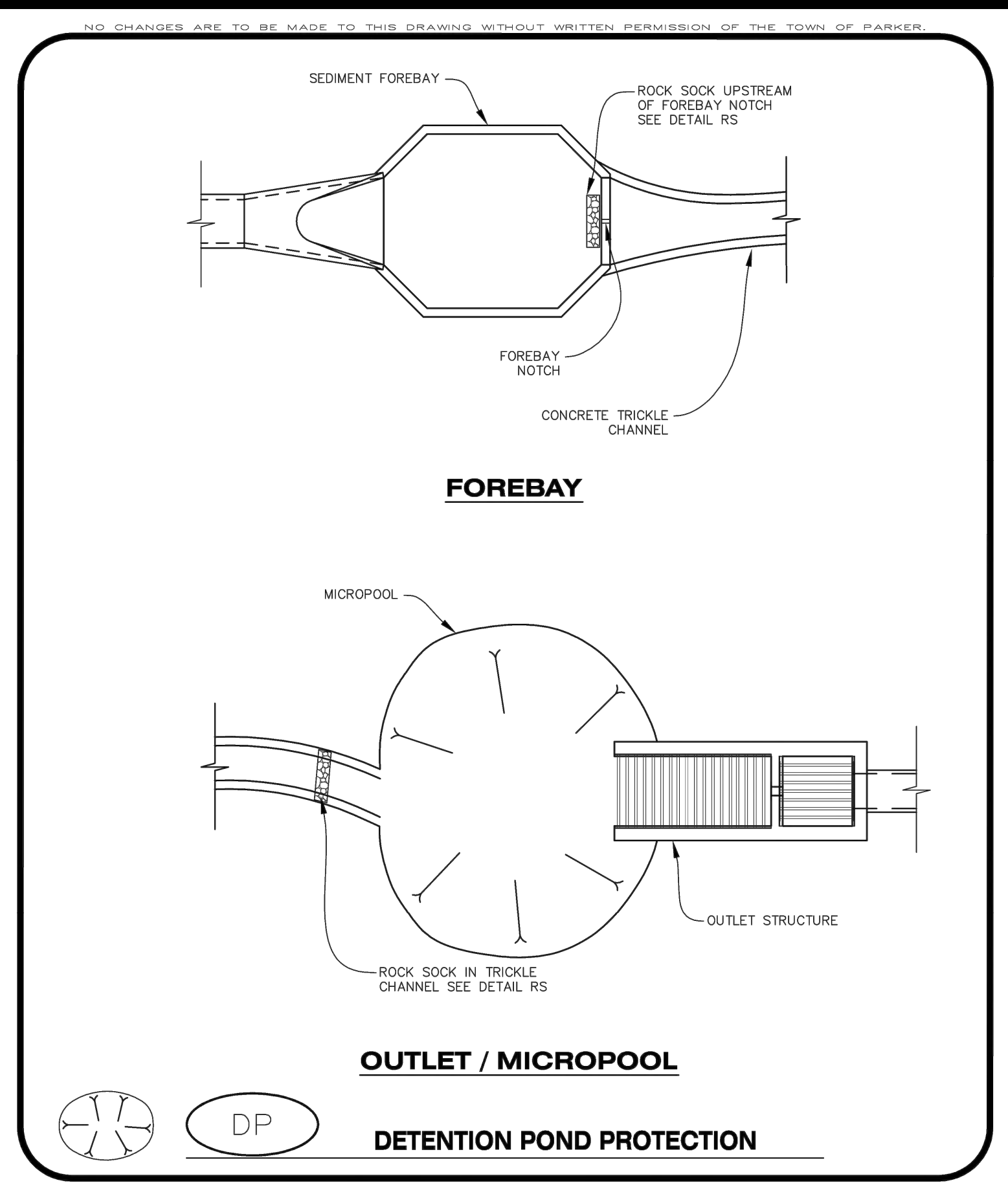

**DP**  
**DETENTION POND PROTECTION**

**CBMP** CONSTRUCTION BEST MANAGEMENT PRACTICES **DP** 1 OF 2 Oct. 2013

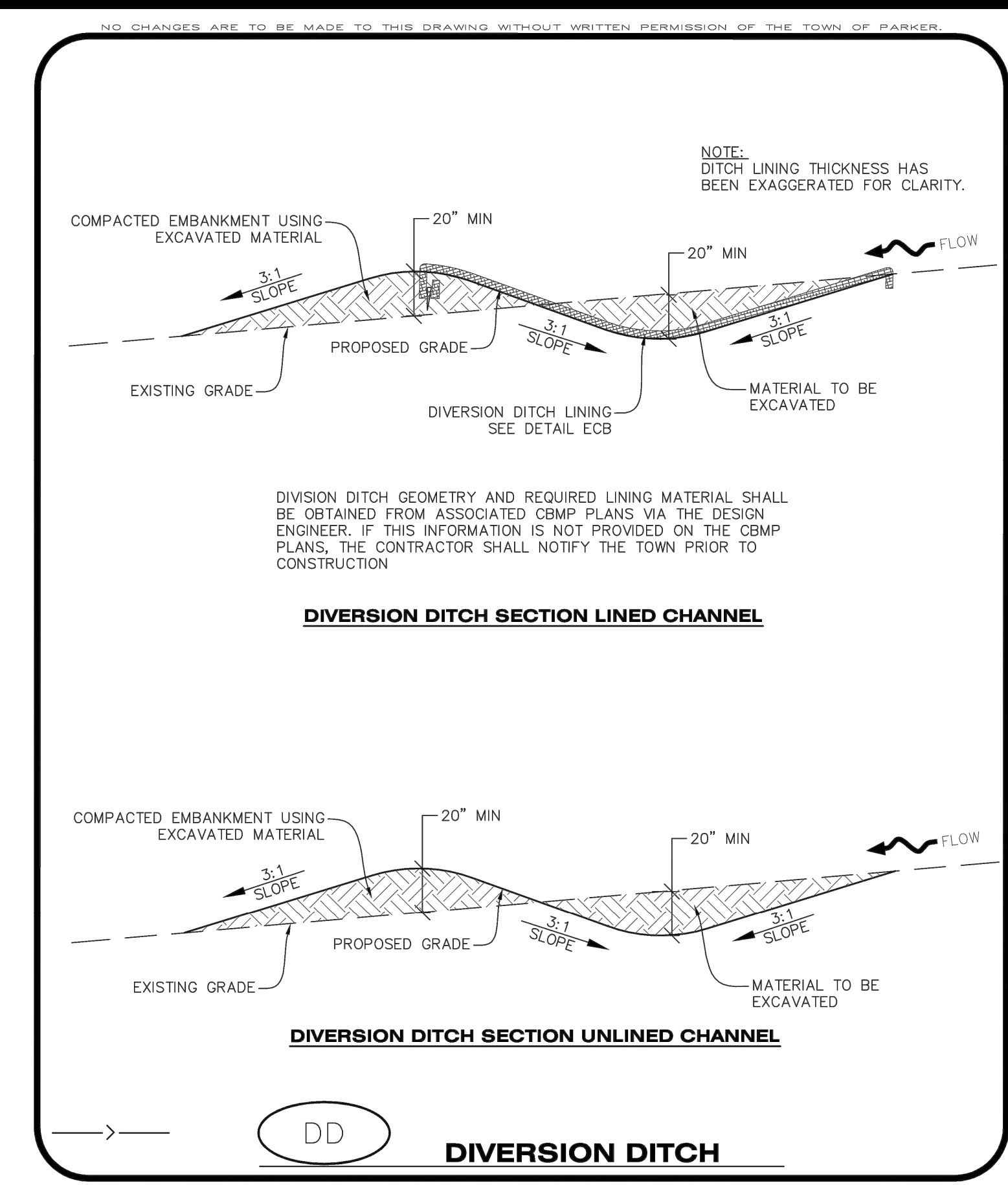

**DD**  
**DIVERSION DITCH**

**CBMP** CONSTRUCTION BEST MANAGEMENT PRACTICES **DD** 1 OF 2 Oct. 2013

**DEBRIS CONTROL NOTES:**

- A COMBINATION OF SURFACE SCRAPING AND SWEEPING MAY BE NECESSARY TO PROPERLY CLEAN THESE AREAS.
- ALL CHEMICAL SPILLS AND/OR STAINS ON THE SITE SHALL BE CLEANED TO THE MAXIMUM EXTENT PRACTICABLE. IN SOME CASES IT MAY BE NECESSARY TO USE PRESSURIZED WATER AND A VAC-TRUCK.
- ON-SITE PERSONNEL, DELIVERY DRIVERS, ETC., SHOULD BE EDUCATED ON THE NEED FOR CONTINUAL DEBRIS AND TRASH CONTROL.

**DTC**  
**DEBRIS CONTROL**

**CBMP** CONSTRUCTION BEST MANAGEMENT PRACTICES **DTC** 2 OF 2 Oct. 2013

**DETENTION POND PROTECTION INSTALLATION NOTES**

- DETENTION POND PROTECTION SHALL BE INSTALLED IMMEDIATELY FOLLOWING THE CONSTRUCTION OF THE TRICKLE CHANNEL AND FOREBAY.
- CRUSHED ROCK SHALL BE 2.0"-3.0" IN SIZE WITH A FRACTURED FACE (ALL SIDES).
- ROCK SOCK FOR OUTLET STRUCTURE AND FOREBAY PROTECTION SHALL BE ONE CONTINUOUS PIECE (SEE DETAIL RS).

**DETENTION POND PROTECTION INSPECTION AND MAINTENANCE NOTES**

- THE EROSION CONTROL SUPERVISOR SHALL REGULARLY INSPECT THE OUTLET STRUCTURE PROTECTION.
- ACCUMULATED SEDIMENT SHALL BE REMOVED IMMEDIATELY.
- OUTLET STRUCTURE PROTECTION SHALL REMAIN IN PLACE AND PROPERLY MAINTAINED UNTIL VEGETATIVE COVER HAS REACHED A CONSISTENT DENSITY OF AT LEAST 70% OF FULL VEGETATIVE COVER AND EROSION AND SEDIMENTATION IS NO LONGER A POSSIBILITY AS DETERMINED BY THE TOWN'S INSPECTOR OR AS OTHERWISE DIRECTED BY THE TOWN'S INSPECTOR.

**DP**  
**DETENTION POND PROTECTION**

**CBMP** CONSTRUCTION BEST MANAGEMENT PRACTICES **DP** 2 OF 2 Oct. 2013

**DIVERSION DITCH INSTALLATION NOTES**

- SEE THE PLAN VIEW FOR THE LOCATION(S) OF THE DIVERSION DITCHES.
- A PLASTIC LINER, RIPRAP, OR EROSION CONTROL BLANKET MAY BE NECESSARY TO PROTECT THE DIVERSION DITCH. THE REQUIRED LINING MATERIAL SHALL BE OBTAINED FROM THE CBMP PLANS VIA THE DESIGN ENGINEER.
- ALL MATERIAL EXCAVATED FROM THE DITCH MAY BE USED TO CONSTRUCT THE BERM ON THE DOWNHILL SIDE OF THE DITCH.
- THE DIVERSION DITCH SHALL BE A MINIMUM OF 20" DEEP WITH APPROX. 3:1 SIDE SLOPES. THE ADJACENT BERM SHALL BE A MINIMUM OF 20" IN HEIGHT WITH APPROX. 3:1 SIDE SLOPES. ALL EMBANKMENTS SHALL BE FIRMLY COMPACTED.
- THE DISCHARGE FROM THE DIVERSION DITCH SHALL BE DIRECTED TOWARDS AN APPROPRIATELY SIZED TEMPORARY SEDIMENT BASIN OR OTHER APPROVED AREA.

**DIVERSION DITCH INSPECTION AND MAINTENANCE NOTES**

- THE EROSION CONTROL SUPERVISOR SHALL REGULARLY INSPECT THE DIVERSION DITCH.
- ACCUMULATED SEDIMENT SHALL BE REMOVED ONCE THE SEDIMENT HAS REACHED A DEPTH EQUAL TO 1/2 (10") THE CREST HEIGHT.
- DIVERSION DITCHES SHALL BE RE-GRADED FOLLOWING THE SIGNS OF MODERATE OR MORE SOIL EROSION OR ANY DAMAGE.
- DIVERSION DITCHES ARE TO REMAIN IN PLACE AND PROPERLY MAINTAINED UNTIL VEGETATIVE COVER HAS REACHED A CONSISTENT DENSITY OF AT LEAST 70% OF FULL VEGETATIVE COVER AND EROSION AND SEDIMENTATION IS NO LONGER A POSSIBILITY AS DETERMINED BY THE TOWN'S INSPECTOR OR AS OTHERWISE DIRECTED BY THE TOWN'S INSPECTOR. ALTERNATIVELY, THE DIVERSION DITCHES MAY BE REMOVED WHEN THE SITE'S TOPOGRAPHY CHANGES SUCH THAT SIGNIFICANT RUNOFF IS NO LONGER POSSIBLE. IN SOME INSTANCES, THE DIVERSION DITCHES MAY REMAIN IN PLACE PERMANENTLY.

**DD**  
**DIVERSION DITCH**

**CBMP** CONSTRUCTION BEST MANAGEMENT PRACTICES **DD** 2 OF 2 Oct. 2013

FILE LOCATION: S:\CIRCLE K\MIAMI & JORDAN\1100 DIVISION 14 PLAN SETS\CONSTRUCTION PLANS\CBMP.DWG

NO CHANGES ARE TO BE MADE TO THIS DRAWING WITHOUT WRITTEN PERMISSION OF THE TOWN OF PARKER.  
THIS METHOD OF INLET PROTECTION SHALL NOT BE USED ON INLETS RECEIVING SIGNIFICANT FLOWS, SUCH AS IN CERTAIN SWALES/CHANNELS OR HIGHWAY MEDIANS. INLET PROTECTION FOR AREA INLETS IN PAVEMENT (SEE DETAIL IPAP) SHALL BE USED IN THESE CONDITIONS.

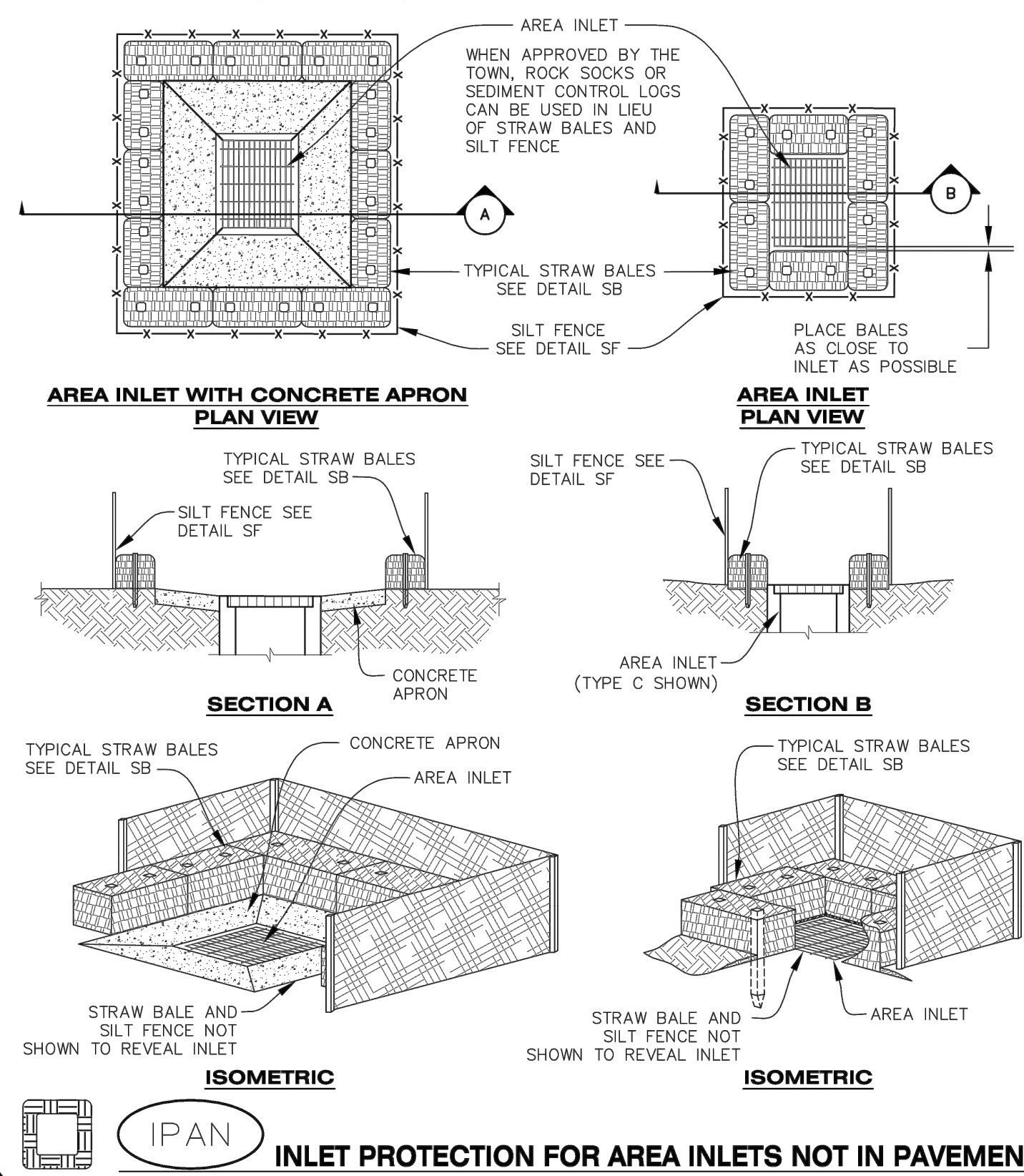

**IPAN** INLET PROTECTION FOR AREA INLETS NOT IN PAVEMENT

**Town of Parker** COLORADO **CBMP** CONSTRUCTION BEST MANAGEMENT PRACTICES **IPAN** 1 OF 1 Oct. 2013

NO CHANGES ARE TO BE MADE TO THIS DRAWING WITHOUT WRITTEN PERMISSION OF THE TOWN OF PARKER.

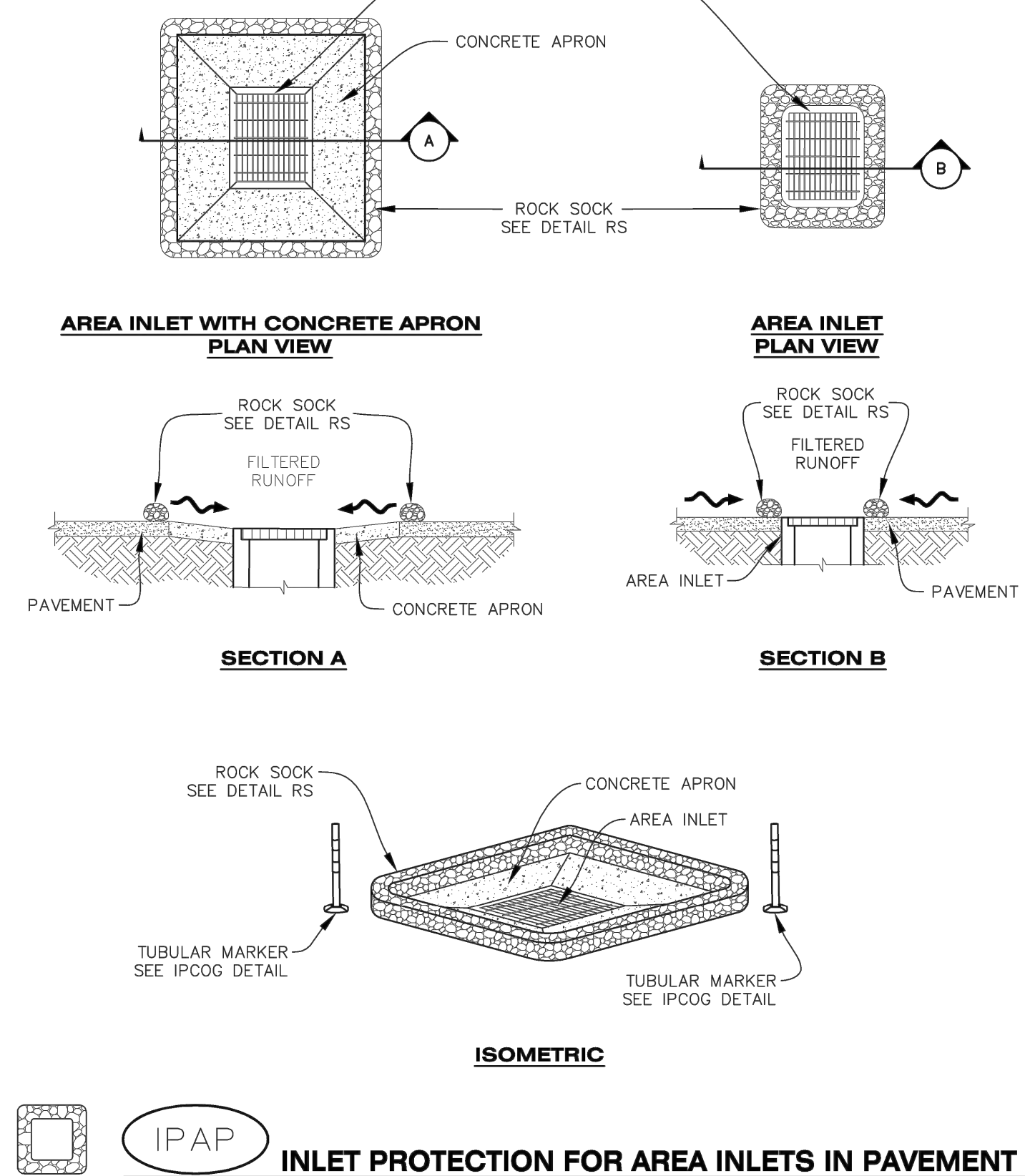

**IPAP** INLET PROTECTION FOR AREA INLETS IN PAVEMENT

**Town of Parker** COLORADO **CBMP** CONSTRUCTION BEST MANAGEMENT PRACTICES **IPAP** 1 OF 1 Oct. 2013

NO CHANGES ARE TO BE MADE TO THIS DRAWING WITHOUT WRITTEN PERMISSION OF THE TOWN OF PARKER.

**AREA INLET PROTECTION INSTALLATION NOTES**

1. SEE PLAN VIEW FOR LOCATION(S) OF AREA INLET PROTECTION.
2. THE AREA INLET PROTECTION SHOWN ON CBMP PLANS SHALL BE INSTALLED ON EXISTING INLETS PRIOR TO ANY LAND DISTURBING ACTIVITIES OR IMMEDIATELY AFTER THE INSTALLATION OF NEW INLETS. AN INTERIM STYLE OF INLET PROTECTION MAY BE ALLOWED UNTIL THE INSTALLATION OF THE GUTTER AND/OR PAVEMENT.

**AREA INLET PROTECTION INSPECTION AND MAINTENANCE NOTES**

1. THE EROSION CONTROL SUPERVISOR SHALL REGULARLY INSPECT THE AREA INLET PROTECTION.
2. AREA INLET PROTECTION SHALL REMAIN IN PLACE AND PROPERLY MAINTAINED UNTIL VEGETATIVE COVER HAS REACHED A CONSISTENT DENSITY OF AT LEAST 70% OF FULL VEGETATIVE COVER AND EROSION AND SEDIMENTATION IS NO LONGER A POSSIBILITY AS DETERMINED BY THE TOWN'S INSPECTOR OR AS OTHERWISE DIRECTED BY THE TOWN'S INSPECTOR.
3. WHEN THE AREA INLET PROTECTION IS REMOVED, ANY DISTURBED AREAS ASSOCIATED WITH THE INSTALLATION, MAINTENANCE, AND/OR REMOVAL OF THE AREA INLET PROTECTION MAY NEED TO BE ROUGHENED, SEEDED, MULCHED, AND CRIMPED PER THE TOWN'S SPECIFICATIONS (SEE DETAIL SMC).
4. ACCUMULATED SEDIMENT SHALL BE REMOVED AS SOON AS POSSIBLE, IMMEDIATELY IN MOST CASES.

**Town of Parker** COLORADO **CBMP** CONSTRUCTION BEST MANAGEMENT PRACTICES **IPA** 1 OF 1 Oct. 2013

NO CHANGES ARE TO BE MADE TO THIS DRAWING WITHOUT WRITTEN PERMISSION OF THE TOWN OF PARKER.

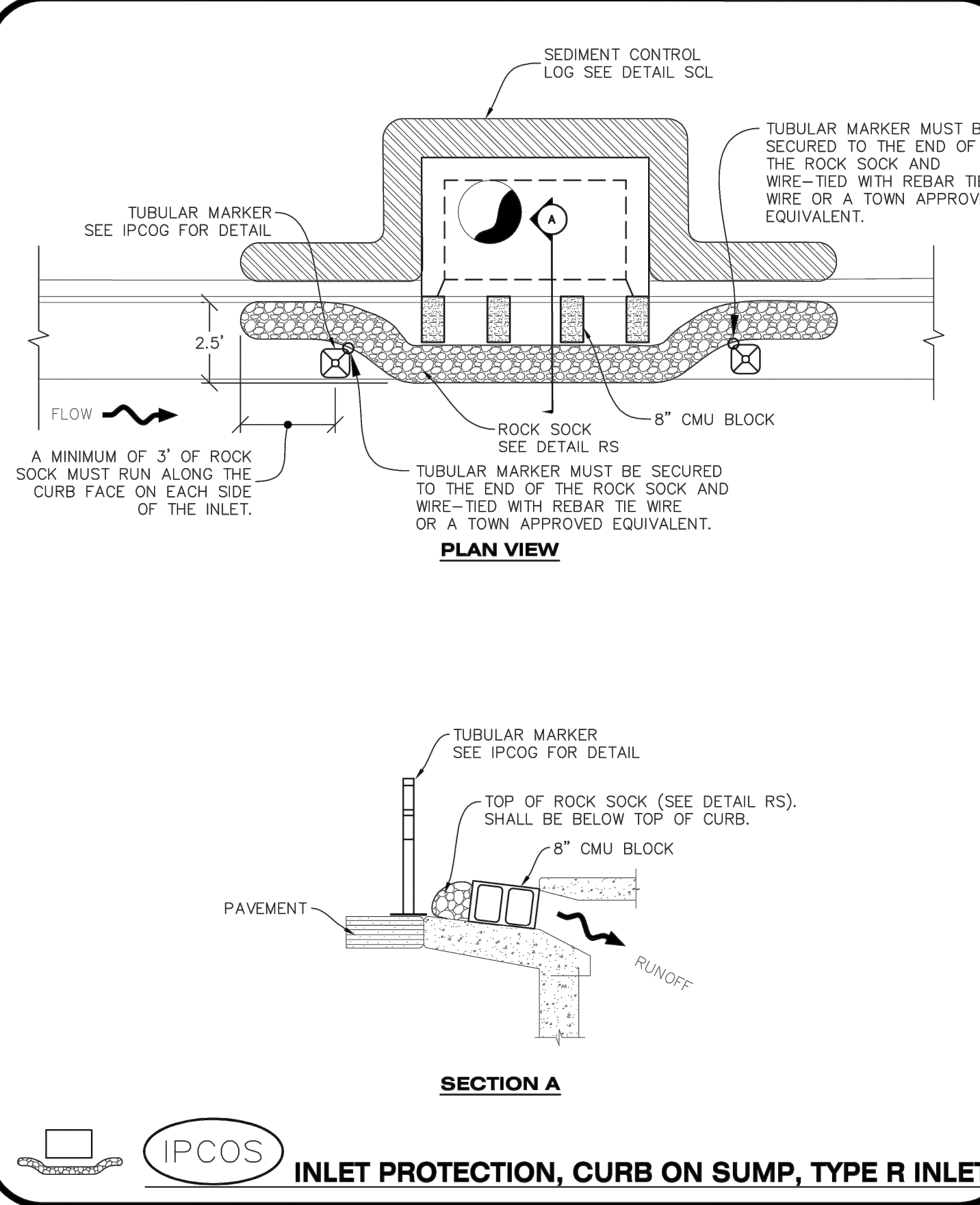

**IPCOS** INLET PROTECTION, CURB ON SUMP, TYPE R INLET

**Town of Parker** COLORADO **CBMP** CONSTRUCTION BEST MANAGEMENT PRACTICES **IPCOS** 1 OF 2 Oct. 2013

NO CHANGES ARE TO BE MADE TO THIS DRAWING WITHOUT WRITTEN PERMISSION OF THE TOWN OF PARKER.

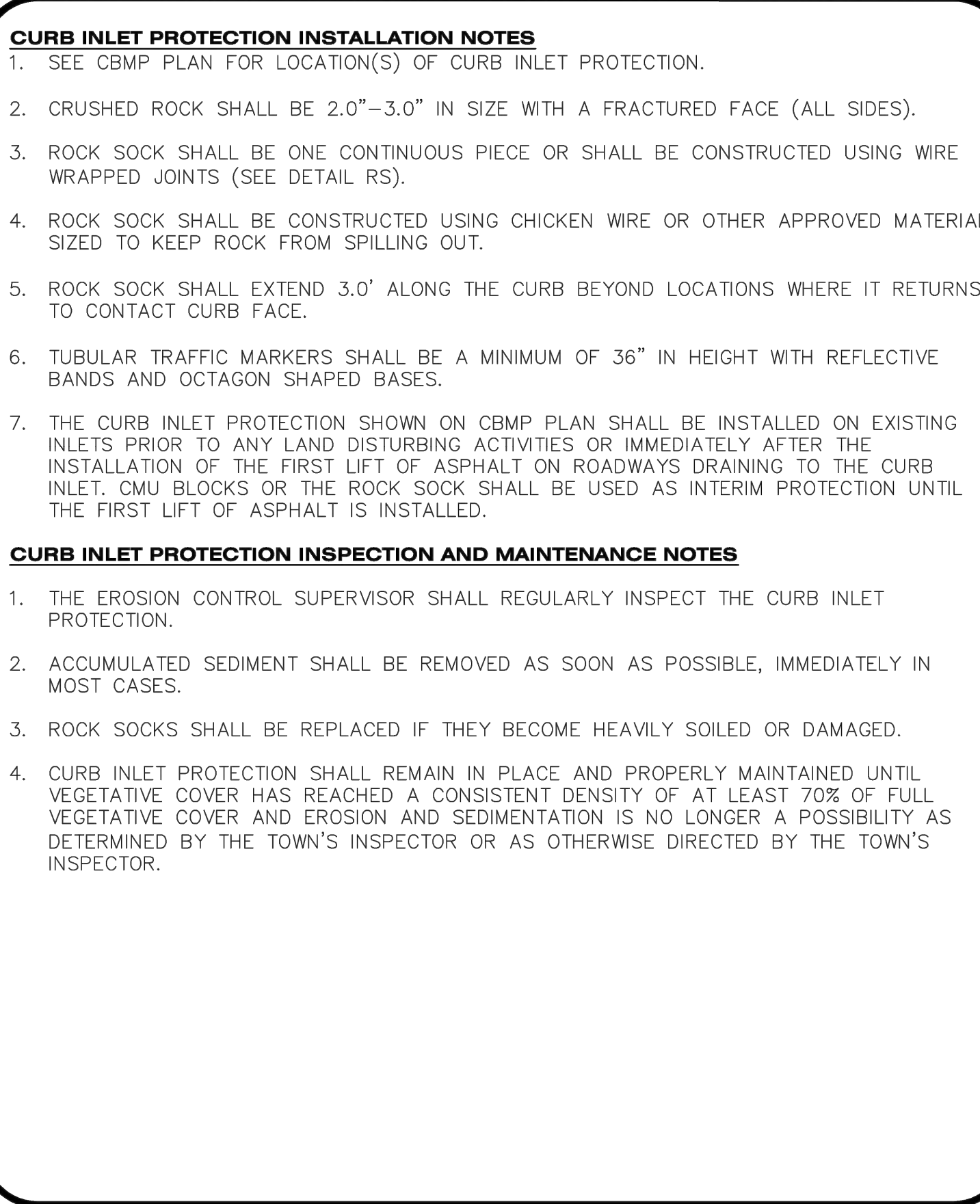

**RSS** ROCK SOCK IN SWALE

**Town of Parker** COLORADO **CBMP** CONSTRUCTION BEST MANAGEMENT PRACTICES **IPCOS** 2 OF 2 Oct. 2013

NO CHANGES ARE TO BE MADE TO THIS DRAWING WITHOUT WRITTEN PERMISSION OF THE TOWN OF PARKER.

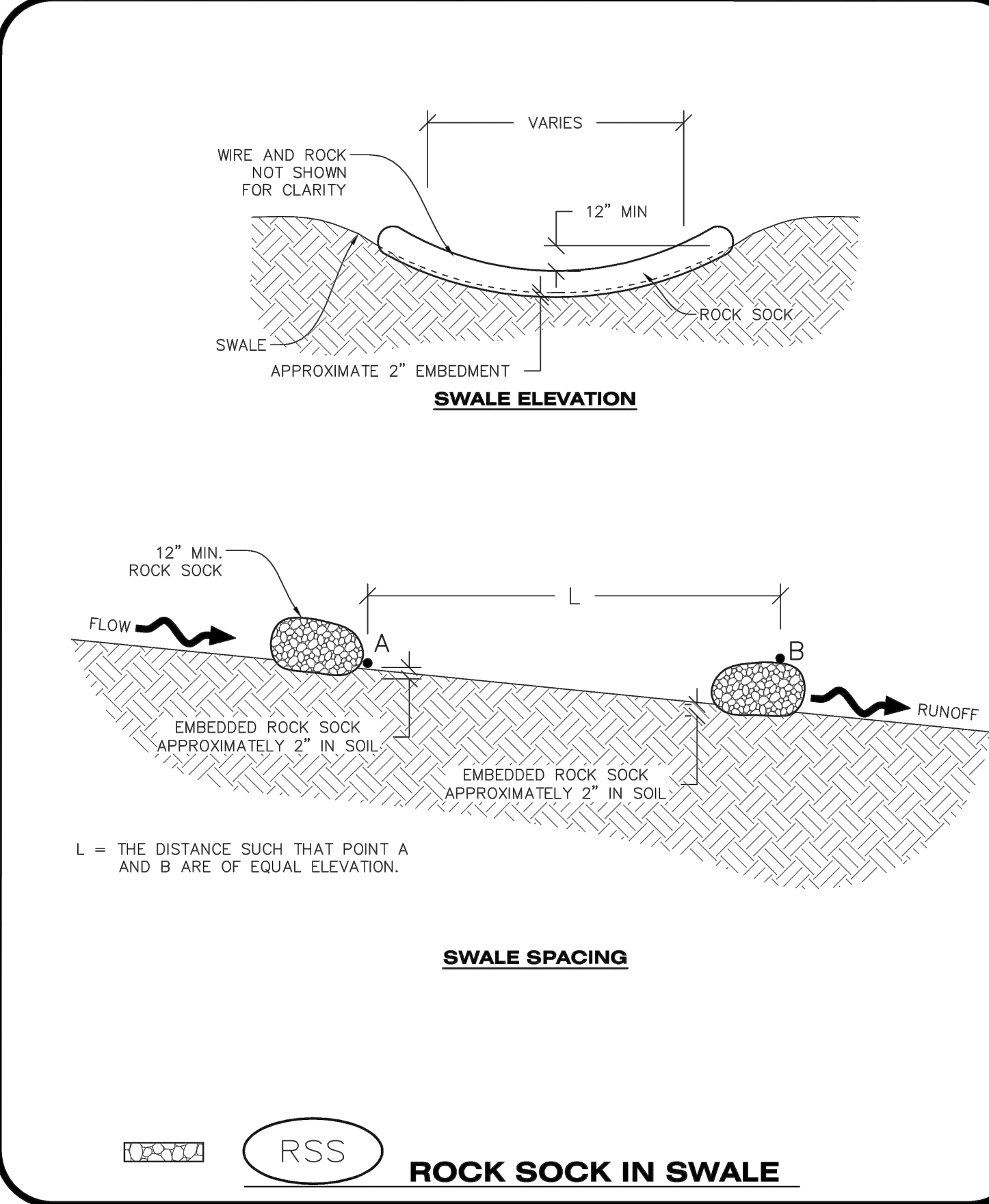

**RSS** ROCK SOCK IN SWALE

**Town of Parker** COLORADO **CBMP** CONSTRUCTION BEST MANAGEMENT PRACTICES **RSS** 1 OF 1 Oct. 2013



**Matrix**  
2435 RESEARCH PARKWAY, SUITE 300  
COLORADO SPRINGS, CO 80920  
PHONE: (719) 575-0100  
FAX: (719) 575-0208

**LAND DEVELOPMENT**  
CONSULTANTS, LLC  
950 S. CHERRY STREET, SUITE 512  
DENVER, CO 80246

**CIRCLE K**

ROCKY MOUNTAINS DIVISION  
5500 S. QUEBEC STREET, SUITE 100  
GREENWOOD VILLAGE, CO 80111

PROFESSIONAL ENGINEER  
COLORADO LICENSED  
52434  
W. M. J. JR.

FOR AND ON BEHALF OF MATRIX DESIGN GROUP, INC. CONTRACTOR IS RESPONSIBLE FOR OBTAINING THE MOST RECENT PROJECT CONSTRUCTION DOCUMENTS. MATRIX DESIGN GROUP IS NOT RESPONSIBLE FOR CHANGES, ALTERATIONS, OR USE OF CONSTRUCTION DOCUMENTS PRIOR TO JURISDICTIONAL APPROVAL.

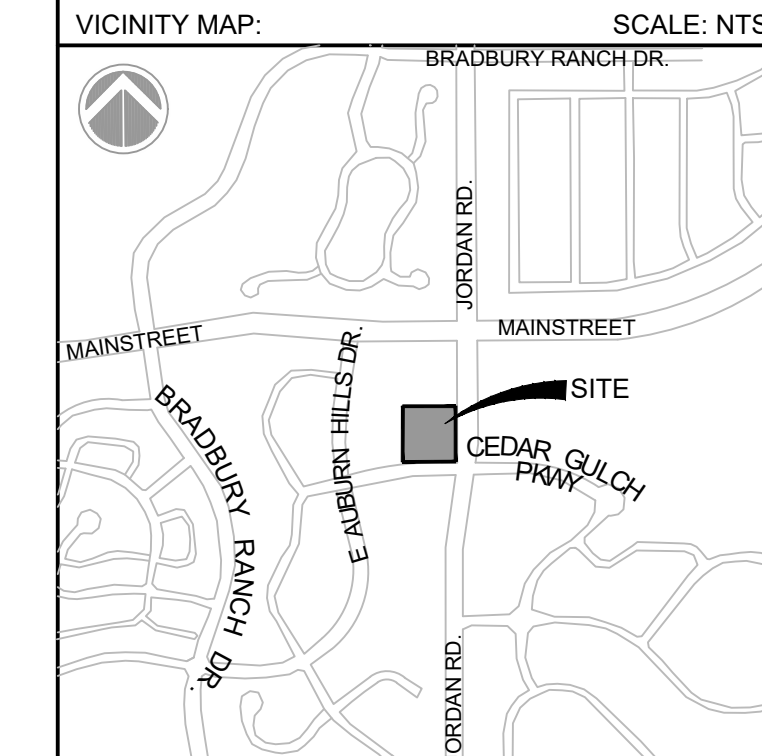

PROJECT:  
**CIRCLE K**  
CONSTRUCTION DOCUMENTS  
16846 E AUBURN HILLS DRIVE  
PARKER, CO 80134

REVISION HISTORY:

NO.	DATE	DESCRIPTION	BY

DRAWING INFORMATION:  
PROJECT NO: 21.1207.030  
DRAWN BY: RAD  
CHECKED BY: NMS  
DESIGNED BY: NMS

SHEET TITLE:  
**CBMP DETAILS**

**C4.7**  
SHEET 16 OF 26

DATE: NOVEMBER 2022

FILE LOCATION: S:\CIRCLE K\MIAMI & JORDAN\1100 DIV\104 PLAN SETS\CONSTRUCTION PLANS\CBMP\1.DWG



**CONSULTANTS:**

**Matrix**  
 2435 RESEARCH PARKWAY, SUITE 300  
 COLORADO SPRINGS, CO 80920  
 PHONE: (719) 575-0100  
 FAX: (719) 575-0208

**LAND DEVELOPMENT**  
 CONSULTANTS, LLC  
 950 S. CHERRY STREET, SUITE 512  
 DENVER, CO 80246

OWNER/DEVELOPER:



FOR AND ON BEHALF OF MATRIX DESIGN GROUP, INC. CONTRACTOR IS RESPONSIBLE FOR OBTAINING THE MOST RECENT PROJECT CONSTRUCTION DOCUMENTS. MATRIX DESIGN GROUP IS NOT RESPONSIBLE FOR CHANGES, ALTERATIONS, OR USE OF CONSTRUCTION DOCUMENTS PRIOR TO JURISDICTIONAL APPROVAL.

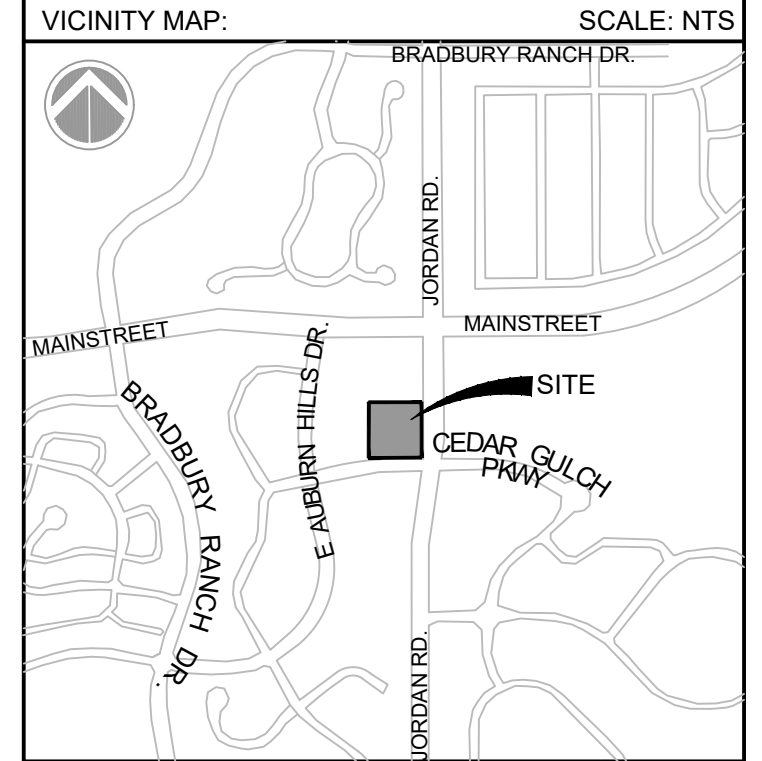

PROJECT:  
**CIRCLE K**  
**CONSTRUCTION DOCUMENTS**  
 16846 E AUBURN HILLS DRIVE  
 PARKER, CO 80134

REVISION HISTORY:

NO.	DATE	DESCRIPTION	BY

DRAWING INFORMATION:  
 PROJECT NO: 21.1207.030  
 DRAWN BY: RAD  
 CHECKED BY: NMS  
 DESIGNED BY: NMS

SHEET TITLE:  
**CBMP DETAILS**

**C4.8**  
 SHEET 17 OF 26

DATE: NOVEMBER 2022

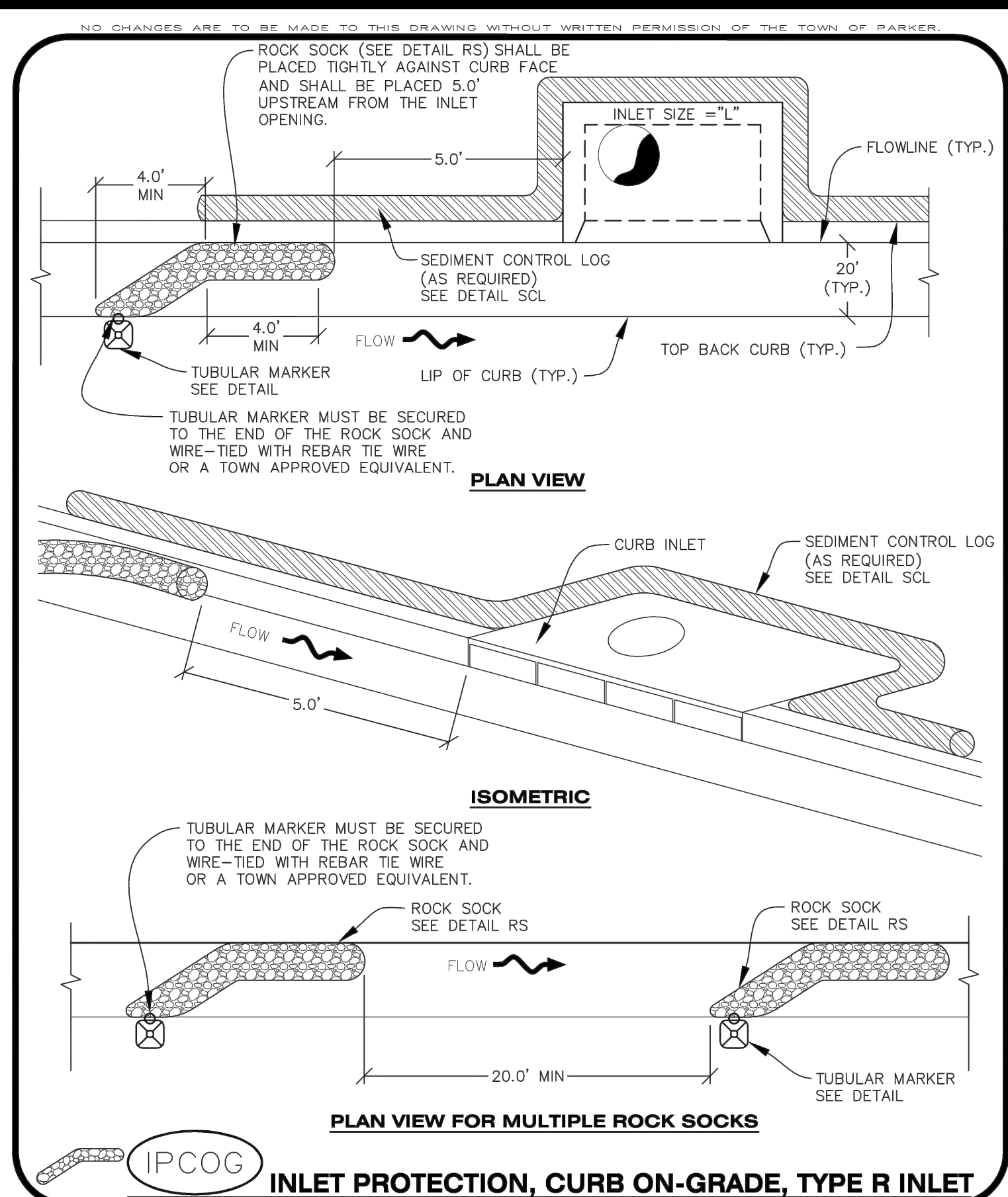

**CBMP**  
 CONSTRUCTION BEST MANAGEMENT PRACTICES  
**IPCOG**  
 1 OF 3  
 Oct. 2013

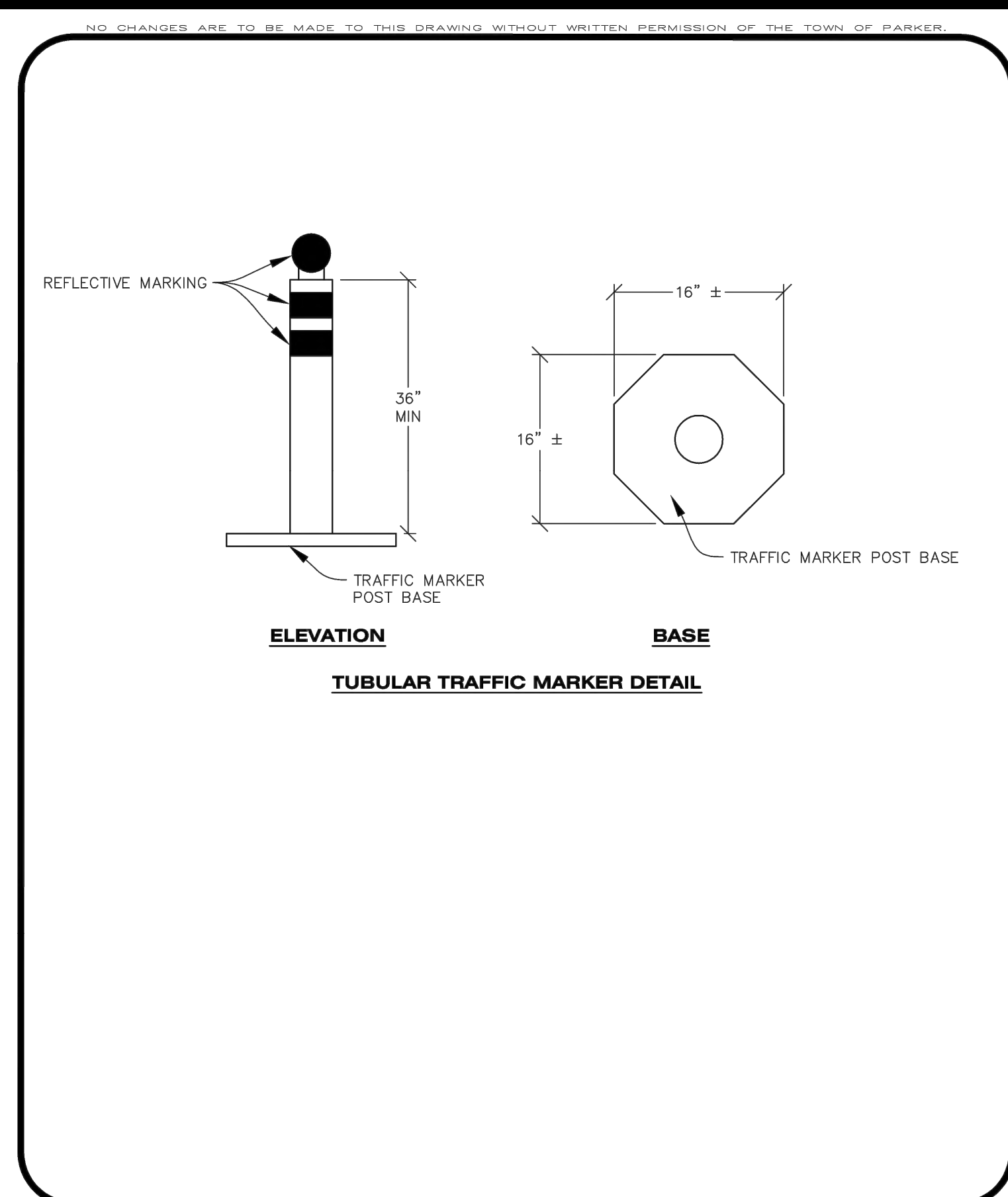

**CBMP**  
 CONSTRUCTION BEST MANAGEMENT PRACTICES  
**IPCOG**  
 2 OF 3  
 Oct. 2013

NO CHANGES ARE TO BE MADE TO THIS DRAWING WITHOUT WRITTEN PERMISSION OF THE TOWN OF PARKER.

**INLET PROTECTION, CURB ON-GRADE INSTALLATION NOTES**

- SEE CBMP PLAN FOR LOCATION(S) OF ON-GRADE INLET PROTECTION.
- CRUSHED ROCK SHALL BE 2.0"-3.0" IN SIZE WITH A FRACTURED FACE (ALL SIDES).
- ROCK SOCK FOR ON-GRADE INLET PROTECTION SHALL BE ONE CONTINUOUS PIECE.
- ROCK SOCK SHALL BE CONSTRUCTED USING CHICKEN WIRE OR OTHER APPROVED MATERIAL, SIZED TO KEEP ROCK FROM SPILLING OUT.
- ROCK SOCK SHALL BE PLACED 5.0' UPHILL OF THE INLET OPENING.
- TUBULAR MARKER SHALL BE A MINIMUM OF 3.0' HIGH WITH REFLECTIVE BANDS AND OCTAGON SHAPED BASES.
- THE CURB INLET PROTECTION SHOWN ON CBMP PLAN SHALL BE INSTALLED ON EXISTING INLETS PRIOR TO ANY LAND DISTURBING ACTIVITIES OR IMMEDIATELY AFTER THE APPLICABLE INSTALLATION OF THE FIRST LIFT OF ASPHALT ON ROADWAYS DRAINING TO THE INLET.

**ON-GRADE INLET PROTECTION INSPECTION AND MAINTENANCE NOTES**

- THE EROSION CONTROL SUPERVISOR SHALL REGULARLY INSPECT THE ON-GRADE INLET PROTECTION.
- ACCUMULATED SEDIMENT SHALL BE REMOVED AS SOON AS POSSIBLE, IMMEDIATELY IN MOST CASES.
- ROCK SOCKS SHALL BE REPLACED IF THEY BECOME HEAVILY SOILED OR DAMAGED.
- ON-GRADE INLET PROTECTION SHALL REMAIN IN PLACE AND PROPERLY MAINTAINED UNTIL VEGETATIVE COVER HAS REACHED A CONSISTENT DENSITY OF AT LEAST 70% OF FULL VEGETATIVE COVER AND EROSION AND SEDIMENTATION IS NO LONGER A POSSIBILITY AS DETERMINED BY THE TOWN'S INSPECTOR OR AS OTHERWISE DIRECTED BY THE TOWN'S INSPECTOR.

**CBMP**  
 CONSTRUCTION BEST MANAGEMENT PRACTICES  
**IPCOG**  
 3 OF 3  
 Oct. 2013

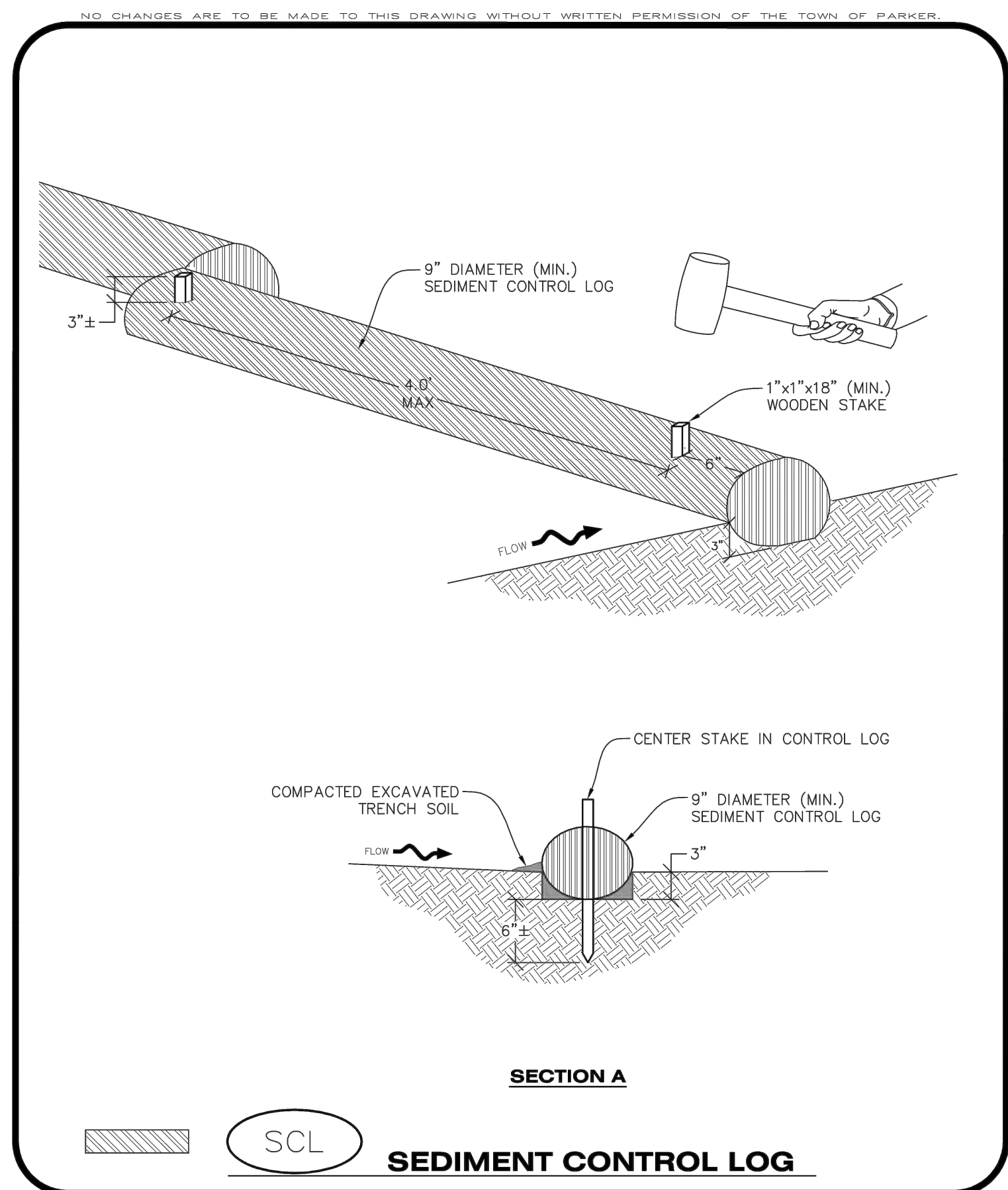

**CBMP**  
 CONSTRUCTION BEST MANAGEMENT PRACTICES  
**SCL**  
 1 OF 3  
 Oct. 2013

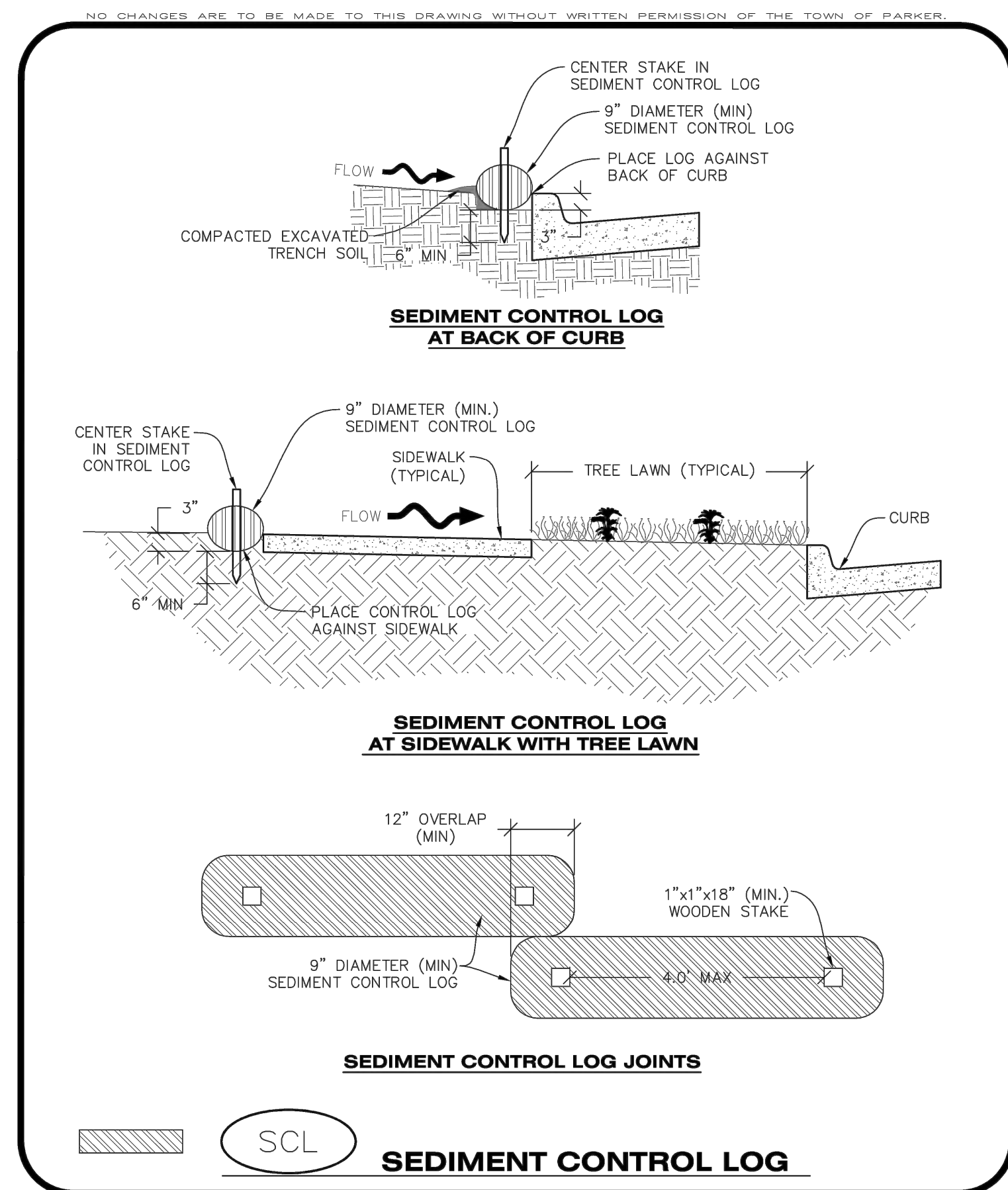

**CBMP**  
 CONSTRUCTION BEST MANAGEMENT PRACTICES  
**SCL**  
 2 OF 3  
 Oct. 2013

NO CHANGES ARE TO BE MADE TO THIS DRAWING WITHOUT WRITTEN PERMISSION OF THE TOWN OF PARKER.

**SEDIMENT CONTROL LOG INSTALLATION NOTES**

- SEE CBMP PLAN FOR LOCATION(S) OF SEDIMENT CONTROL LOGS.
- ALL SEDIMENT CONTROL LOGS SHALL BE INSTALLED FREE OF DEFECTS INCLUDING RIPS, HOLES AND OBVIOUS WEAR.
- SEDIMENT CONTROL LOGS SHALL BE INSTALLED IMMEDIATELY ADJACENT TO AN IMPERVIOUS SURFACE SUCH AS A CURB HEAD, SIDEWALK, INLET LID, ETC. NO GAPS SHALL EXIST BETWEEN THE SEDIMENT CONTROL LOG AND THE IMPERVIOUS SURFACE.
- A UNIFORM 3" DEEP ANCHOR TRENCH (APPROX.) IN THE SHAPE OF A HALF-SPHERE SHALL BE EXCAVATED USING A TRENCHER, SPADE-SHAPED SHOVEL, OR PICK. THE ANCHOR TRENCH SHALL BE SIZED TO ALLOW FOR THE SEDIMENT CONTROL LOG TO SEAT TIGHTLY AGAINST THE ANCHOR TRENCH.
- EXCAVATED MATERIAL SHALL BE PLACED ON THE UPHILL SIDE OF THE ANCHOR TRENCH AND PROPERLY COMPACTED.
- ANCHOR TRENCH SHALL BE RELATIVELY FREE OF ROCKS OR OTHER DEBRIS PRIOR TO THE PLACEMENT.
- ALL SEDIMENT CONTROL LOGS SHALL BE PLACED 3" (APPROX.) BELOW THE GROUND AND PULLED TIGHT ON BOTH ENDS TO REMOVE ANY CURVES OR SNAGS.
- THE UPHILL SIDE OF THE SEDIMENT CONTROL LOG SHALL BE BACKFILLED WITH SOIL THAT IS RELATIVELY FREE OF ROCKS AND DEBRIS. THE SOIL SHALL BE TIGHTLY COMPACTED AGAINST THE GROUND AND SEDIMENT CONTROL LOG USING A SHOVEL, OR SIMILAR DEVICE.
- SEDIMENT CONTROL LOG STAKES SHALL BE MADE OF WOOD AND SECURELY ANCHOR THE SCL IN PLACE.
- STAKES SHALL BE PLACED ON 4.0' CENTERS AND EMBEDDED APPROXIMATELY 6" INTO THE GROUND. STAKES THAT ARE BROKEN PRIOR TO OR DURING INSTALLATION SHALL BE REPLACED.
- SEDIMENT CONTROL LOGS SHALL OVERLAP A MINIMUM OF 12". THE OVERLAPPING SHALL OCCUR ON THE UP-GRADE SIDE OF THE LOGS.
- SEDIMENT CONTROL LOGS SHALL BE STAKED WITHIN 6" FROM EACH END.
- SEDIMENT CONTROL LOGS THAT ARE INSTALLED BEHIND CURBS AND SIDEWALKS MUST BE DONE SO THAT NO MORE THAN A 2" GAP EXISTS BETWEEN THE CONCRETE AND THE LOG. EROSION CONTROL BLANKETING (ECB) BETWEEN THE GAP MAY BE REQUIRED IN INSTANCES WHERE THIS DOES NOT OCCUR.

**SEDIMENT CONTROL LOG INSPECTION AND MAINTENANCE NOTES**

- THE EROSION CONTROL SUPERVISOR SHALL REGULARLY INSPECT THE SEDIMENT CONTROL LOGS.
- ACCUMULATED SEDIMENT SHALL BE REMOVED ONCE THE SEDIMENT HAS REACHED A DEPTH EQUAL TO 1/2 THE HEIGHT OF EXPOSED LOG.
- SEDIMENT CONTROL LOGS SHALL REMAIN IN PLACE AND PROPERLY MAINTAINED UNTIL VEGETATIVE COVER HAS REACHED A CONSISTENT DENSITY OF AT LEAST 70% OF FULL VEGETATIVE COVER AND EROSION AND SEDIMENTATION IS NO LONGER A POSSIBILITY AS DETERMINED BY THE TOWN'S INSPECTOR OR AS OTHERWISE DIRECTED BY THE TOWN'S INSPECTOR.
- SEDIMENT CONTROL LOGS SHALL BE REPLACED WHEN THERE ARE ANY SIGNS OF WEAR OR DAMAGE THAT WOULD PREVENT THE SCL FROM FUNCTIONING AS DESIGNED.
- WHEN THE SEDIMENT CONTROL LOGS ARE REMOVED, ANY DISTURBED AREAS ASSOCIATED WITH THE INSTALLATION, MAINTENANCE, AND/OR REMOVAL OF THE SEDIMENT CONTROL LOGS MAY NEED TO BE ROUGHENED, SEEDED, MULCHED, AND CRIMPED PER THE TOWN'S SPECIFICATIONS (SEE DETAIL SMC).

**CBMP**  
 CONSTRUCTION BEST MANAGEMENT PRACTICES  
**SCL**  
 3 OF 3  
 Oct. 2013

FILE LOCATION: S:\CIRCLE K\AUBURN & JORDAN\1100 DIVISION\104 PLAN SETS\CONSTRUCTION PLANS\CBMP\1.DWG



CONSULTANTS:  
**Matrix**  
 2435 RESEARCH PARKWAY, SUITE 300  
 COLORADO SPRINGS, CO 80920  
 PHONE: (719) 575-0100  
 FAX: (719) 575-0208

**D**  
**LAND DEVELOPMENT**  
 CONSULTANTS, LLC  
 950 S. CHERRY STREET, SUITE 512  
 DENVER, CO 80246  
 OWNER/DEVELOPER:



SEAL

FOR AND ON BEHALF OF MATRIX DESIGN GROUP, INC  
 CONTRACTOR IS RESPONSIBLE FOR OBTAINING THE MOST RECENT PROJECT CONSTRUCTION DOCUMENTS.  
 MATRIX DESIGN GROUP IS NOT RESPONSIBLE FOR CHANGES, ALTERATIONS, OR USE OF CONSTRUCTION DOCUMENTS PRIOR TO JURISDICTIONAL APPROVAL.

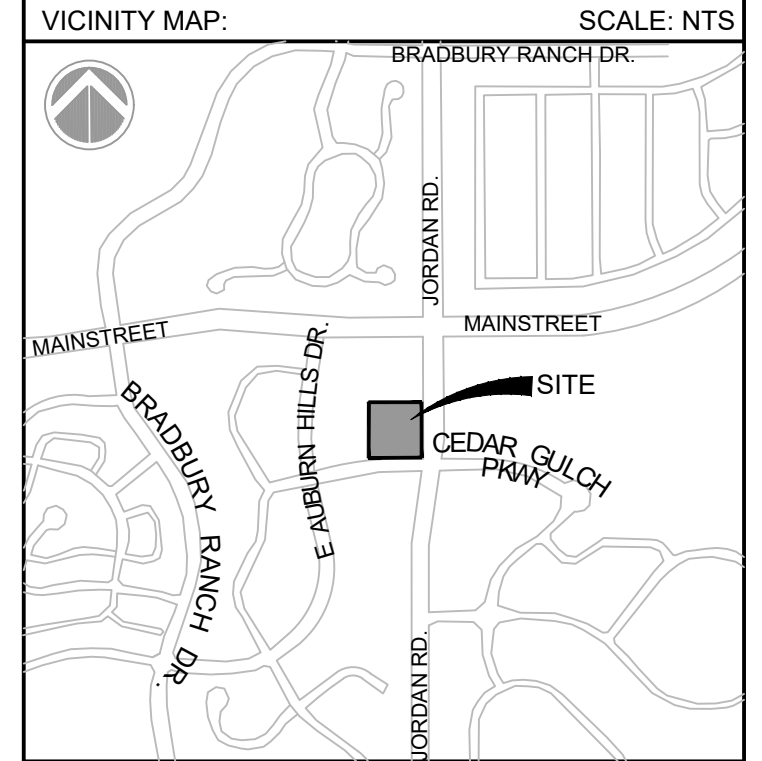

PROJECT:  
**CIRCLE K**  
**CONSTRUCTION DOCUMENTS**  
 16846 E AUBURN HILLS DRIVE  
 PARKER, CO 80134

REVISION HISTORY:

NO.	DATE	DESCRIPTION	BY

DRAWING INFORMATION:  
 PROJECT NO: 21.1207.030  
 DRAWN BY: RAD  
 CHECKED BY: NMS  
 DESIGNED BY: NMS  
 SHEET TITLE:

**CBMP DETAILS**

**C4.9**  
**SHEET 18 OF 26**  
 DATE: NOVEMBER 2022

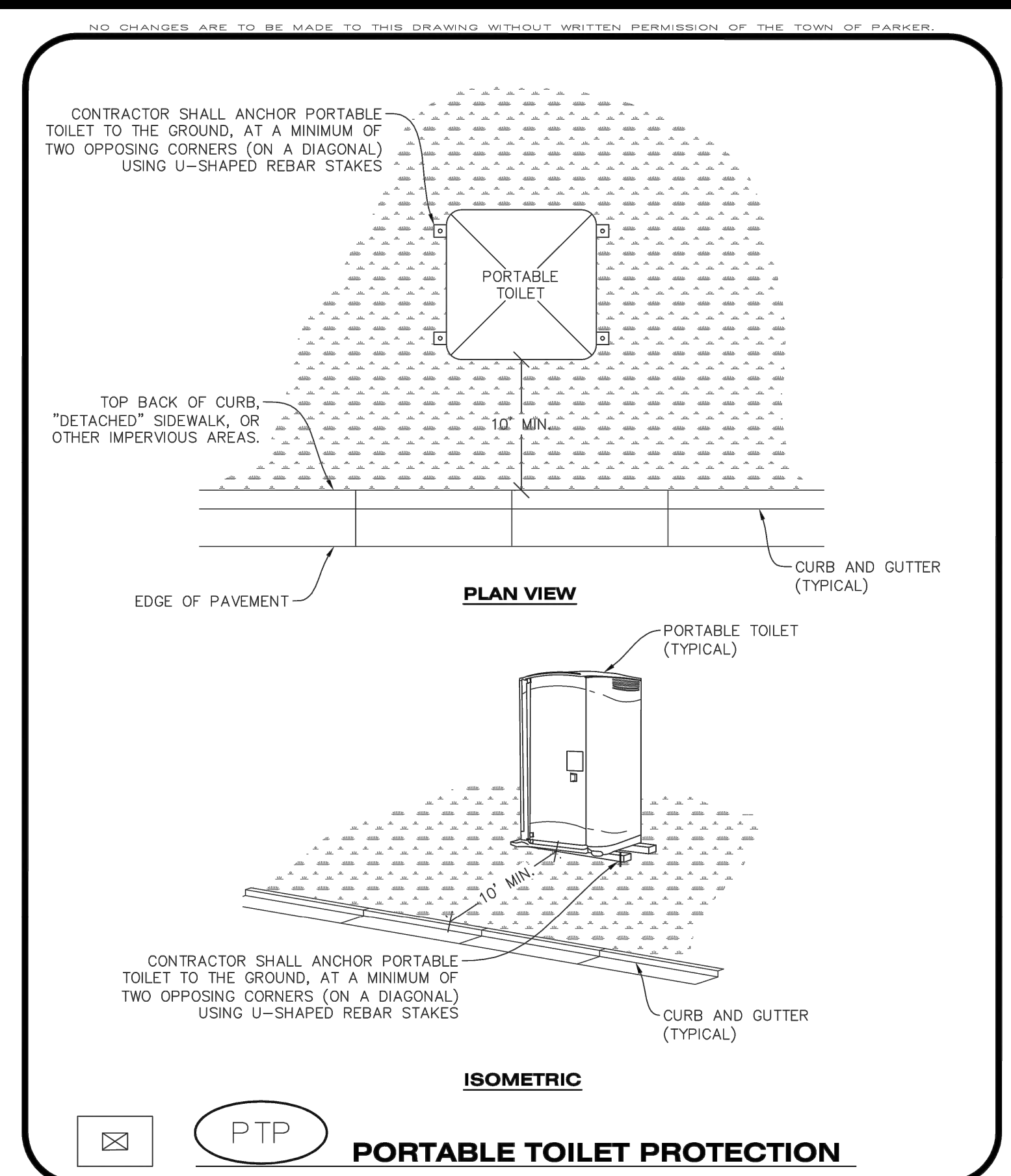

**CBMP** CONSTRUCTION BEST MANAGEMENT PRACTICES **PTP** 1 OF 2 Oct. 2013

NO CHANGES ARE TO BE MADE TO THIS DRAWING WITHOUT WRITTEN PERMISSION OF THE TOWN OF PARKER.

**PORTABLE TOILET PROTECTION INSTALLATION NOTES**

- PORTABLE TOILETS SHALL BE PLACED A MINIMUM OF 10.0' BEHIND ALL CURBS, SIDEWALKS, AND OTHER IMPERVIOUS AREAS.
- ALL PORTABLE TOILETS MUST BE GROUPED TOGETHER.
- PORTABLE TOILETS SHALL BE SECURELY ANCHORED TO THE GROUND USING U-SHAPED REBAR STAKES.
- U-SHAPED REBAR STAKES SHALL BE POSITIONED ON AT LEAST 2 OPPOSING (DIGITAL) CORNERS.

**PORTABLE TOILET PROTECTION INSPECTION AND MAINTENANCE NOTES**

- THE EROSION CONTROL SUPERVISOR SHALL REGULARLY INSPECT THE PORTABLE TOILET PROTECTION.
- WHEN THE PORTABLE TOILETS ARE REMOVED, ANY DISTURBED AREAS ASSOCIATED WITH THE INSTALLATION, MAINTENANCE, AND/OR REMOVAL OF THE TOILETS MAY NEED TO BE LANDSCAPED OR ROUGHENED, SEEDED, MULCHED, AND CRIMPED PER THE TOWN'S SPECIFICATIONS (SEE DETAIL SMC).
- PORTABLE TOILETS SHALL BE SERVICED AT THE NECESSARY INTERVALS TO ELIMINATE THE POSSIBILITY OF OVERFLOW.
- WHEN THE PORTABLE TOILETS ARE REMOVED, ANY DISTURBED AREAS ASSOCIATED WITH THE INSTALLATION, MAINTENANCE, AND/OR REMOVAL OF THE TOILETS MAY NEED TO BE LANDSCAPED OR ROUGHENED, SEEDED, MULCHED, AND CRIMPED PER THE TOWN'S SPECIFICATIONS (SEE DETAIL SMC).
- PORTABLE TOILETS THAT ARE NOT CONSISTENTLY MAINTAINED IN ACCORDANCE WITH THESE REQUIREMENTS MAY NEED TO BE CLUSTERED TOGETHER, IN ONE CENTRALIZED LOCATION IN ORDER TO INCREASE COMPLIANCE AND REDUCE THE CHANCE OF A SPILL.

**CBMP** CONSTRUCTION BEST MANAGEMENT PRACTICES **PTP** 2 OF 2 Oct. 2013

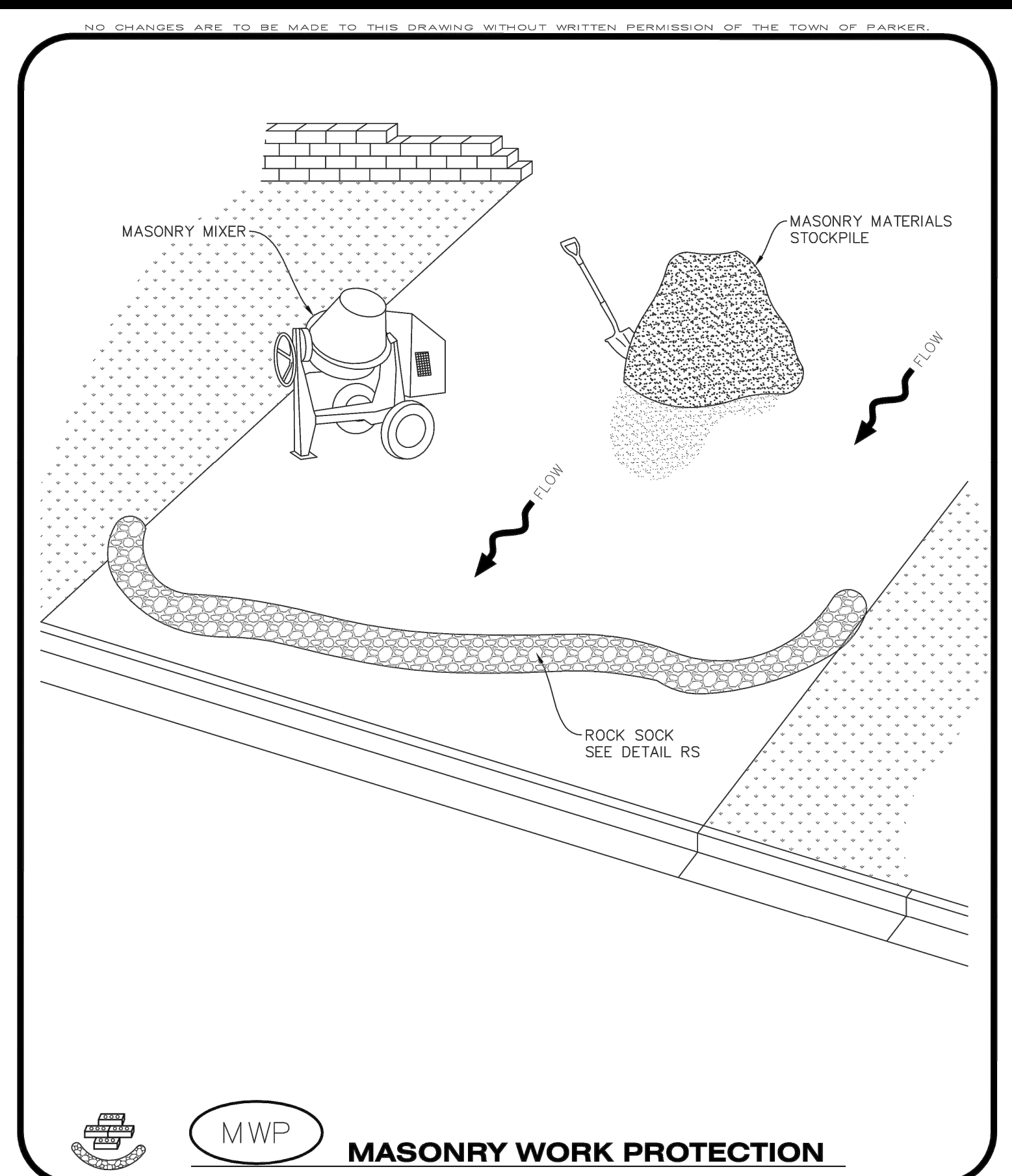

**CBMP** CONSTRUCTION BEST MANAGEMENT PRACTICES **MWP** 1 OF 2 Oct. 2013

NO CHANGES ARE TO BE MADE TO THIS DRAWING WITHOUT WRITTEN PERMISSION OF THE TOWN OF PARKER.

**MASONRY WORK PROTECTION INSTALLATION NOTES**

- MASONRY WORK PROTECTION MAY NEED TO BE INSTALLED WHEN MASONRY WORK AND MIXING IS OCCURRING.
- A ROCK SOCK SHALL BE INSTALLED IN A CRESCENT SHAPE ON THE DOWNHILL SIDE OF THE MASONRY WORK AND MIXER.
- CRUSHED ROCK SHALL BE 2.0"-3.0" IN SIZE WITH A FRACTURED FACE (ALL SIDES).
- ROCK SOCK SHALL BE ONE CONTINUOUS PIECE OR SHALL BE CONSTRUCTED USING WIRE WRAPPED JOINTS (SEE DETAIL RS).
- ROCK SOCK SHALL BE CONSTRUCTED USING CHICKEN WIRE OR OTHER APPROVED MATERIAL, SIZED TO KEEP ROCK FROM SPILLING OUT.

**MASONRY WORK PROTECTION INSPECTION AND MAINTENANCE NOTES**

- THE EROSION CONTROL SUPERVISOR SHALL REGULARLY INSPECT THE MASONRY WORK PROTECTION.
- ALL CONCRETE WASTE SHALL BE REGULARLY CLEANED AND PLACED IN THE CONCRETE WASH OUT AREA.
- ROCK SOCKS SHALL BE REPLACED IF THEY BECOME HEAVILY SOILED OR DAMAGED.

**CBMP** CONSTRUCTION BEST MANAGEMENT PRACTICES **MWP** 2 OF 2 Oct. 2013

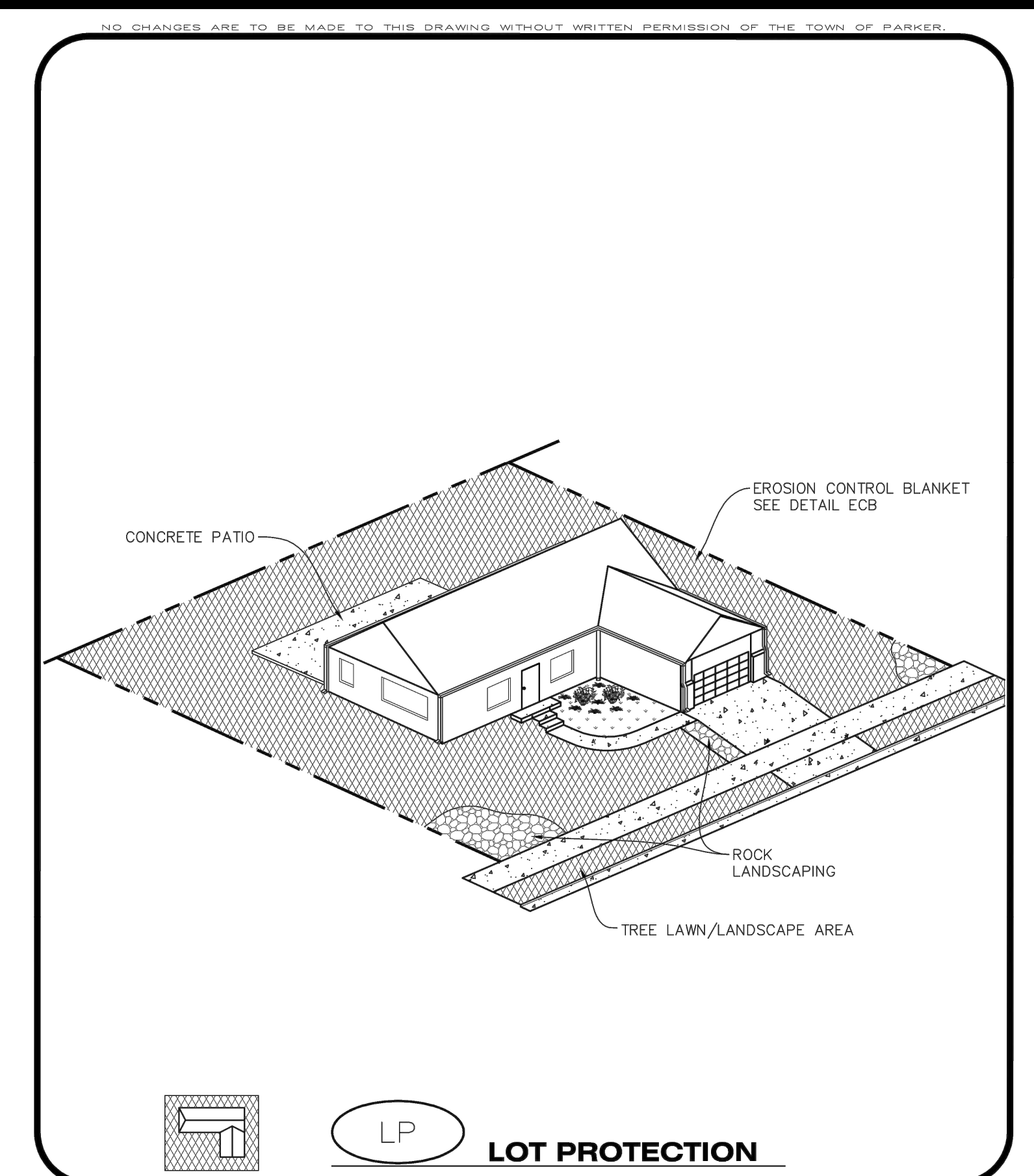

**CBMP** CONSTRUCTION BEST MANAGEMENT PRACTICES **LP** 1 OF 2 Oct. 2013

NO CHANGES ARE TO BE MADE TO THIS DRAWING WITHOUT WRITTEN PERMISSION OF THE TOWN OF PARKER.

**EROSION CONTROL BLANKET FOR LOT PROTECTION INSTALLATION NOTES**

- ALL EROSION CONTROL BLANKETS FOR LOT PROTECTION INSTALLED IN THE TOWN SHALL MEET THE FOLLOWING MINIMUM REQUIREMENTS:

MANUFACTURER	PRODUCT NAME
NORTH AMERICAN GREEN	S150 BN
APPROVED EQUAL	APPROVED EQUAL

- ALL EROSION CONTROL BLANKETS FOR LOT PROTECTION SHALL BE INSTALLED ACCORDING TO THE DETAIL DRAWINGS, WITH THE FOLLOWING ALLOWANCES AND ADDITIONS:
  - THE TOWN WILL ALLOW THE USE OF BIODEGRADABLE, EROSION CONTROL BLANKET-SPECIFIC STAPLES, IN LIEU OF TRADITIONAL METAL STAPLES.
  - ALL EROSION CONTROL BLANKET EDGES (SIDES AND ENDS) MUST OVERLAP THE ADJACENT BLANKET BY A MINIMUM OF 6-INCHES WITH THE UP-GRADIENT EDGES BEING PLACED ON TOP OF THE DOWN-GRADIENT EDGE OF THE ADJACENT BLANKET.
  - THE EDGES (SIDES AND ENDS) OF THE EROSION CONTROL BLANKETS DO NOT NEED TO BE TRENCHED INTO THE GROUND ASSUMING THE SITE CONDITIONS WILL NOT CAUSE EROSION BENEATH THE BLANKETS. THESE ASSUMPTIONS WILL BE THE RESPONSIBILITY OF THE EROSION CONTROL SUPERVISOR. ON OCCASION, THE TOWN'S INSPECTOR MAY REQUEST TRENCHING BASED UPON SITE CONDITIONS.
  - TOPSOIL PLACEMENT, SEEDING, AND MULCHING WILL NOT BE REQUIRED ON THE LOTS PRIOR TO THE INSTALLATION OF THE EROSION CONTROL BLANKET.
- ANY DAMAGED OR EXCESS STAPLES SHALL BE REMOVED FROM THE SITE FOLLOWING INSTALLATION.
- THE EROSION CONTROL BLANKETING REQUIRED AS PART OF THE LOT PROTECTION (LP) REQUIREMENT MUST BE INSTALLED OVER ALL UN-LANDSCAPED AREAS WITHIN EACH RESIDENTIAL, MULTI-FAMILY, AND COMMERCIAL LOT PRIOR TO THE ISSUANCE OF A CERTIFICATE OF OCCUPANCY / TEMPORARY CERTIFICATE OF OCCUPANCY.

**EROSION CONTROL BLANKET FOR LOT PROTECTION MAINTENANCE NOTES**

- THE EROSION CONTROL SUPERVISOR SHALL REGULARLY INSPECT THE EROSION CONTROL BLANKET FOR LOT PROTECTION.
- EROSION CONTROL BLANKETS FOR LOT PROTECTION ARE INTENDED TO REMAIN IN PLACE AND MAINTAINED UNTIL LANDSCAPING IS INSTALLED.

**CBMP** CONSTRUCTION BEST MANAGEMENT PRACTICES **LP** 2 OF 2 Oct. 2013

FILE LOCATION: S:\CIRCLE K\MIAMI & JORDAN\1100 DIVISION\14 PLAN SETS\CONSTRUCTION PLANS\CBMP.DWG

NO CHANGES ARE TO BE MADE TO THIS DRAWING WITHOUT WRITTEN PERMISSION OF THE TOWN OF PARKER.

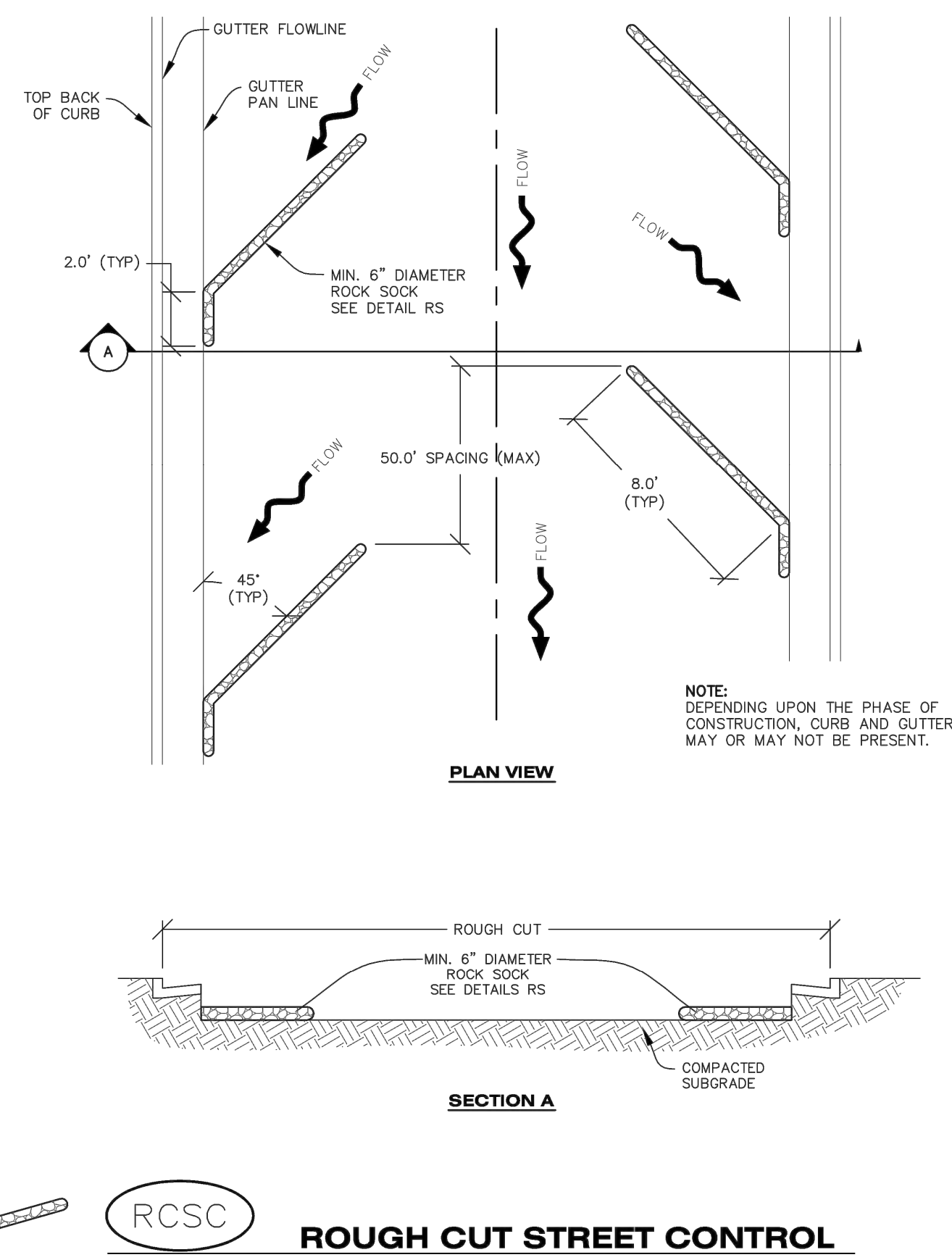

**CBMP** CONSTRUCTION BEST MANAGEMENT PRACTICES  
**RCSC** 1 OF 2 Oct. 2013

NO CHANGES ARE TO BE MADE TO THIS DRAWING WITHOUT WRITTEN PERMISSION OF THE TOWN OF PARKER.

**ROUGH CUT STREET CONTROL INSTALLATION NOTES**

- SEE CBMP PLAN FOR LOCATION(S) OF ROUGH CUT STREET CONTROL.
- THE SPACING OF THE ROUGH CUT STREET CONTROL MAY BE DETERMINED BY THE DESIGN ENGINEER AND SHOWN ON THE CBMP PLAN.

**ROUGH CUT STREET CONTROL INSPECTION AND MAINTENANCE NOTES**

- THE EROSION CONTROL SUPERVISOR SHALL REGULARLY INSPECT THE ROUGH CUT STREET CONTROL.
- ACCUMULATED SEDIMENT SHALL BE REMOVED WHEN THE SEDIMENT DEPTH IS 1/2 THE HEIGHT OF THE ROCK SOCK.
- ROUGH CUT STREET CONTROL SHALL BE REPAIRED IMMEDIATELY FOLLOWING ANY SIGN OF WEAR OR ALTERATION OF THE ORIGINAL SHAPE AND DIMENSIONS.
- ROUGH CUT STREET CONTROL SHALL BE KEPT IN PLACE AND MAINTAINED UNTIL SUB-GRADE PREPARATION BEGINS FOR PAVING. AT THAT POINT, THE RCSC SHOULD BE REMOVED IN INCREMENTS BASED ON SUBGRADE PREPARATION.

**CBMP** CONSTRUCTION BEST MANAGEMENT PRACTICES  
**RCSC** 2 OF 2 Oct. 2013

NO CHANGES ARE TO BE MADE TO THIS DRAWING WITHOUT WRITTEN PERMISSION OF THE TOWN OF PARKER.

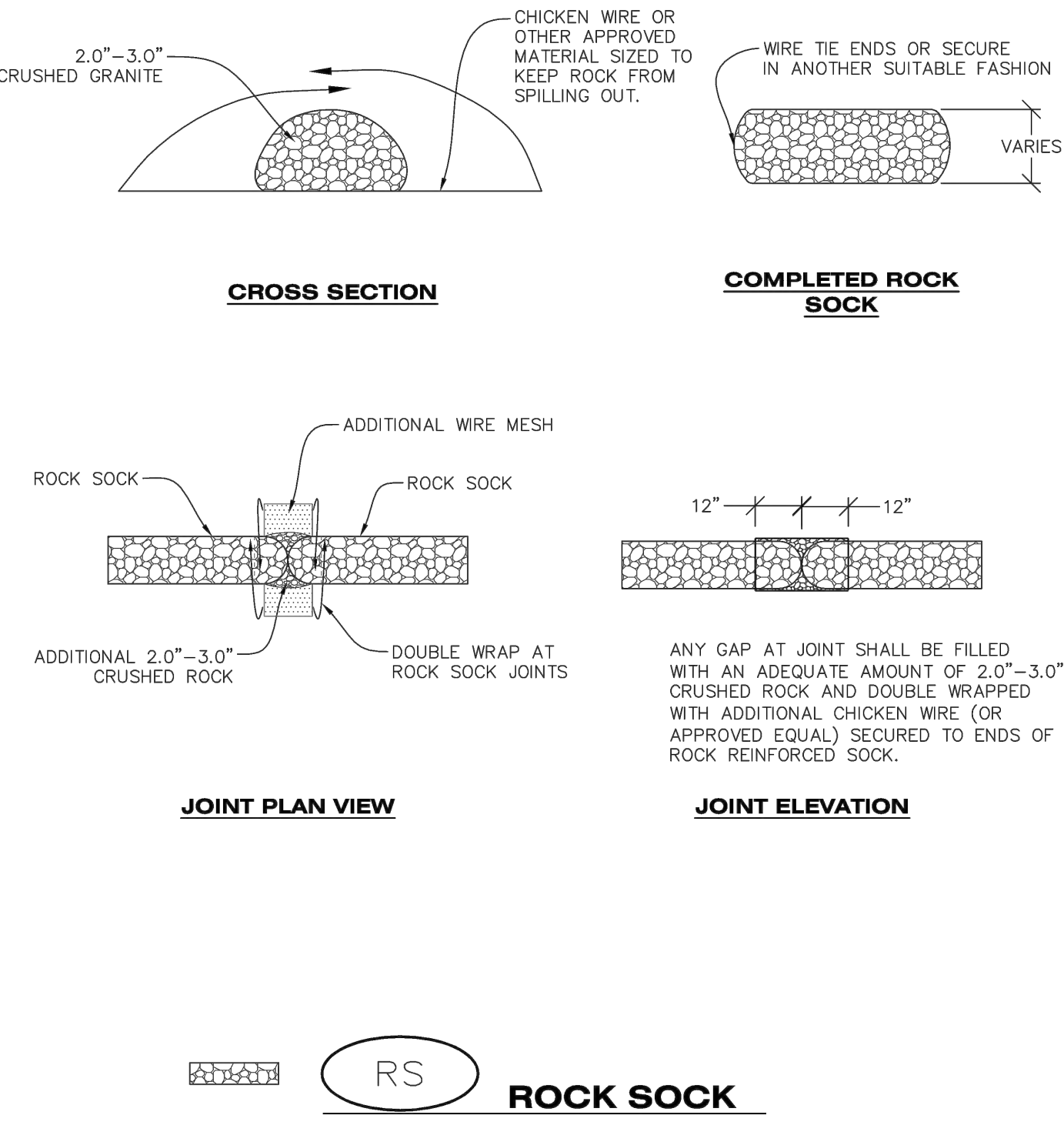

**CBMP** CONSTRUCTION BEST MANAGEMENT PRACTICES  
**RS** 1 OF 2 Oct. 2013

**ROCK SOCK INSTALLATION NOTES**

- SEE CBMP PLAN FOR LOCATION(S) OF ROCK SOCK.
- CRUSHED ROCK SHALL BE APPROXIMATELY 2.0"-3.0" GRANITE IN SIZE WITH A FRACTURED FACE (ALL SIDES).
- ROCK SOCK SHALL BE APPROXIMATELY ONE CONTINUOUS PIECE OR SHALL BE CONSTRUCTED USING WIRE WRAPPED JOINTS (SEE DETAIL RS).
- ROCK SOCK SHALL BE CONSTRUCTED USING CHICKEN WIRE OR OTHER APPROVED MATERIAL SIZED TO KEEP ROCK FROM SPILLING OUT.
- MINIMUM ROCK SOCK DIAMETER SHALL VARY BASED ON APPLICATION (7" MIN).
- TUBULAR MARKERS MAY NEED TO BE USED IN CONJUNCTION WITH ROCK SOCKS ANYTIME THE ROCK SOCK IS PLACED ON A ROADWAY, SIDEWALK, PARKING LOT OR OTHER LOCATION SUSCEPTIBLE TO VEHICLE OR PEDESTRIAN TRAFFIC. TUBULAR MARKERS SHALL CONFORM TO THE TUBULAR MARKER DETAIL.

**ROCK SOCK INSPECTION AND MAINTENANCE NOTES**

- THE EROSION CONTROL SUPERVISOR SHALL REGULARLY INSPECT THE ROCK SOCKS.
- ROCK SOCKS SHALL BE REPLACED IF THEY BECOME HEAVILY SOILED OR DAMAGED.
- ROCK SOCKS SHALL REMAIN IN PLACE AND PROPERLY MAINTAINED UNTIL VEGETATIVE COVER HAS REACHED A CONSISTENT DENSITY OF AT LEAST 70% OF FULL VEGETATIVE COVER AND EROSION AND SEDIMENTATION IS NO LONGER A POSSIBILITY AS DETERMINED BY THE TOWN'S INSPECTOR OR AS OTHERWISE DIRECTED BY THE TOWN'S INSPECTOR.

**CBMP** CONSTRUCTION BEST MANAGEMENT PRACTICES  
**RS** 2 OF 2 Oct. 2013

NO CHANGES ARE TO BE MADE TO THIS DRAWING WITHOUT WRITTEN PERMISSION OF THE TOWN OF PARKER.

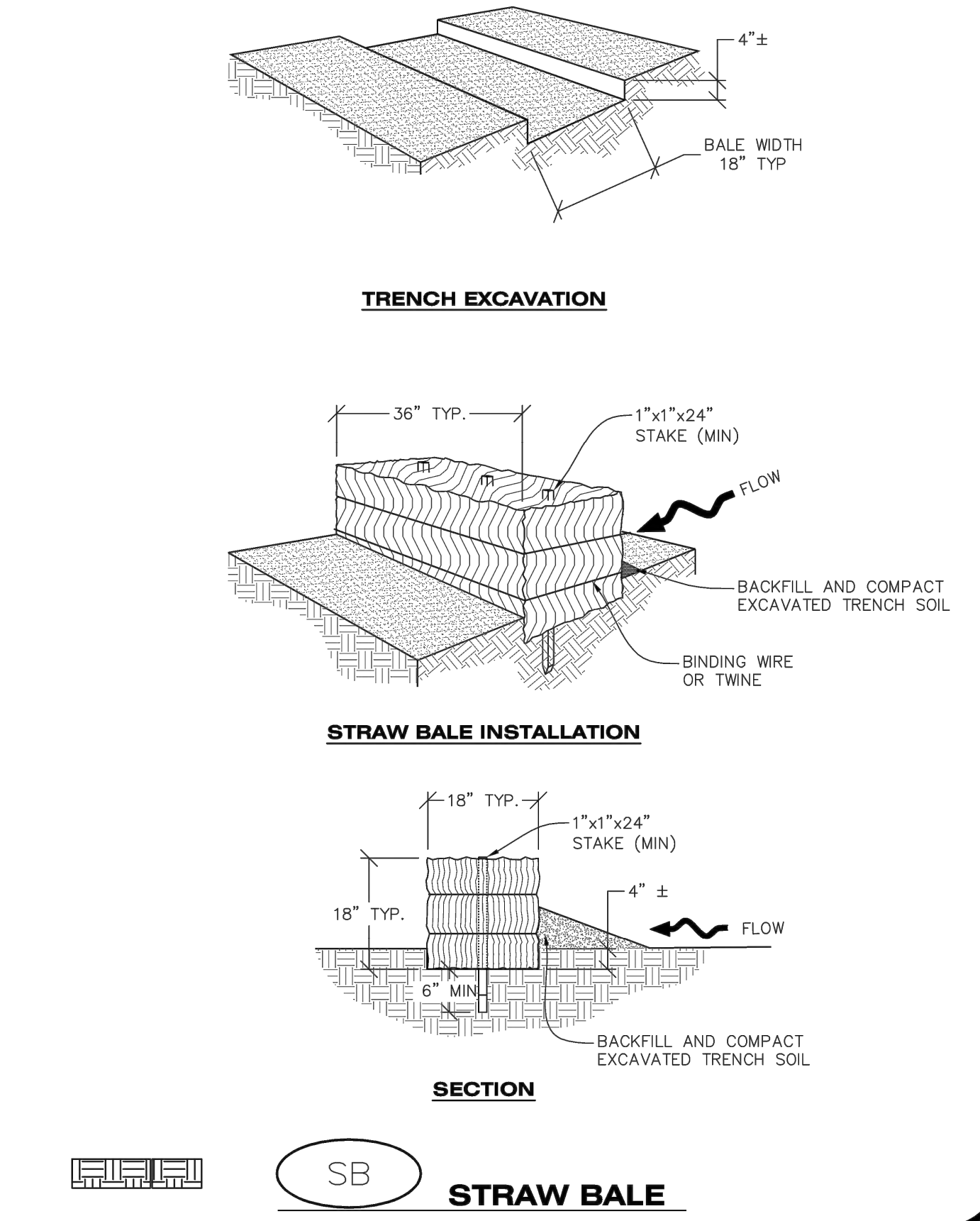

**CBMP** CONSTRUCTION BEST MANAGEMENT PRACTICES  
**SB** 1 OF 2 Oct. 2013

**STRAW BALE INSTALLATION NOTES**

- SEE CBMP PLAN FOR LOCATION(S) OF STRAW BALES.
- TYPICAL STRAW BALES SHALL BE APPROXIMATELY 36"x18"x18".
- TWO (2) WOODEN STAKES SHALL BE USED TO HOLD EACH BALE IN PLACE. WOODEN STAKES SHALL BE A MINIMUM OF 1"x1"x24".
- WOODEN STAKES SHALL BE PLACED APPROXIMATELY 6" INTO THE GROUND.
- STRAW BALES SHALL BE SPACED AND POSITIONED ACCORDING TO DETAILS.

**STRAW BALE INSPECTION AND MAINTENANCE NOTES**

- THE EROSION CONTROL SUPERVISOR SHALL REGULARLY INSPECT THE STRAW BALES.
- ACCUMULATED SEDIMENT SHALL BE REMOVED ONCE THE SEDIMENT HAS REACHED A DEPTH EQUAL TO 1/2 THE HEIGHT OF THE STRAW BALE.
- STRAW BALES MAY NEED TO BE REPLACED IF THEY BECOME HEAVILY SOILED, ROTTEN, OR OTHERWISE DAMAGED.
- STRAW BALES SHALL REMAIN IN PLACE AND PROPERLY MAINTAINED UNTIL VEGETATIVE COVER HAS REACHED A CONSISTENT DENSITY OF AT LEAST 70% OF FULL VEGETATIVE COVER AND EROSION AND SEDIMENTATION IS NO LONGER A POSSIBILITY AS DETERMINED BY THE TOWN'S INSPECTOR OR AS OTHERWISE DIRECTED BY THE TOWN INSPECTOR.
- WHEN THE STRAW BALES ARE REMOVED, ANY DISTURBED AREAS ASSOCIATED WITH THE INSTALLATION, MAINTENANCE, AND/OR REMOVAL OF THE STRAW BALES MAY NEED TO BE ROUGHENED, SEEDED, MULCHED, AND CRIMPED PER THE TOWN'S SPECIFICATIONS (SEE DETAIL SMC).

**CBMP** CONSTRUCTION BEST MANAGEMENT PRACTICES  
**SB** 2 OF 2 Oct. 2013



**Matrix**  
 2435 RESEARCH PARKWAY, SUITE 300  
 COLORADO SPRINGS, CO 80920  
 PHONE: (719) 575-0100  
 FAX: (719) 575-0208

**LAND DEVELOPMENT**  
 CONSULTANTS, LLC  
 950 S. CHERRY STREET, SUITE 512  
 DENVER, CO 80246

OWNER/DEVELOPER:

**CIRCLE K**

ROCKY MOUNTAINS DIVISION  
 5500 S QUEBEC STREET, SUITE 100  
 GREENWOOD VILLAGE, CO 80111

SEAL

FOR AND ON BEHALF OF MATRIX DESIGN GROUP, INC  
 CONTRACTOR IS RESPONSIBLE FOR OBTAINING THE MOST RECENT PROJECT CONSTRUCTION DOCUMENTS.  
 MATRIX DESIGN GROUP IS NOT RESPONSIBLE FOR CHANGES, ALTERATIONS, OR USE OF CONSTRUCTION DOCUMENTS PRIOR TO JURISDICTIONAL APPROVAL.

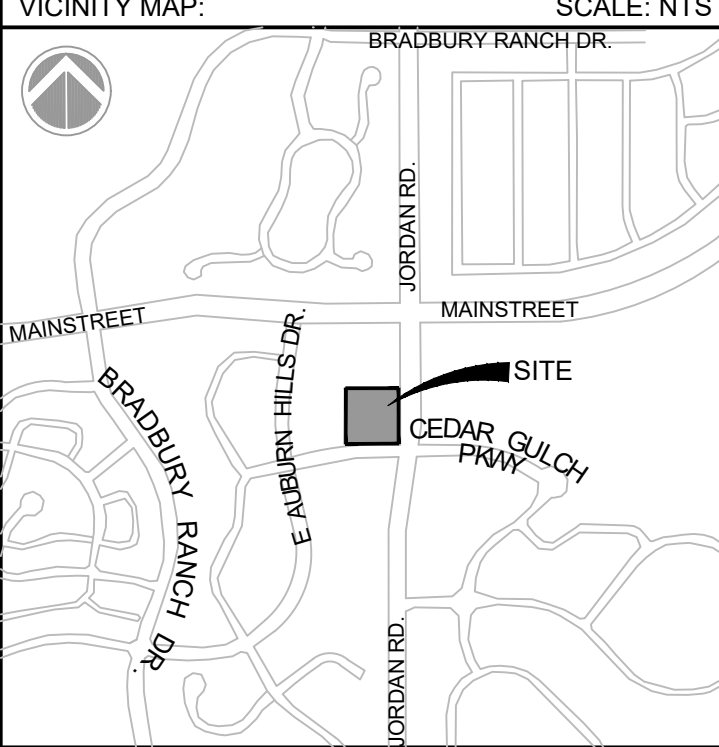

PROJECT:  
**CIRCLE K**  
**CONSTRUCTION DOCUMENTS**  
 16846 E AUBURN HILLS DRIVE  
 PARKER, CO 80134

REVISION HISTORY:

NO.	DATE	DESCRIPTION	BY

DRAWING INFORMATION:  
 PROJECT NO: 21.1207.030  
 DRAWN BY: RAD  
 CHECKED BY: NMS  
 DESIGNED BY: NMS

**CBMP DETAILS**

**C4.10**  
**SHEET 19 OF 26**

DATE: NOVEMBER 2022

FILE LOCATION: S:\CIRCLE K\MIAMI & JORDAN\1100 DIVISION\104 PLAN SETS\CONSTRUCTION PLANS\CBMP.DWG

NO CHANGES ARE TO BE MADE TO THIS DRAWING WITHOUT WRITTEN PERMISSION OF THE TOWN OF PARKER.

A MIN. OF 1"x1"x48" WOODEN STAKES SHALL BE PLACED ON THE DOWNHILL SIDE OF THE SILT FENCE FABRIC. A 1-1/2" X 1/4" STAKE OR LATH SHALL BE STAPLED OR NAILED TO THE 48" STAKE ON THE UPHILL SIDE OF THE FABRIC SUCH THAT IT IS FLUSH AGAINST THE FABRIC AND STAKE. LENGTH OF STAKE IS DEPENDENT UPON HEIGHT OF FENCE. ALSO SEE ALTERNATIVE INSTALLATION - 360° TWIST DETAIL.

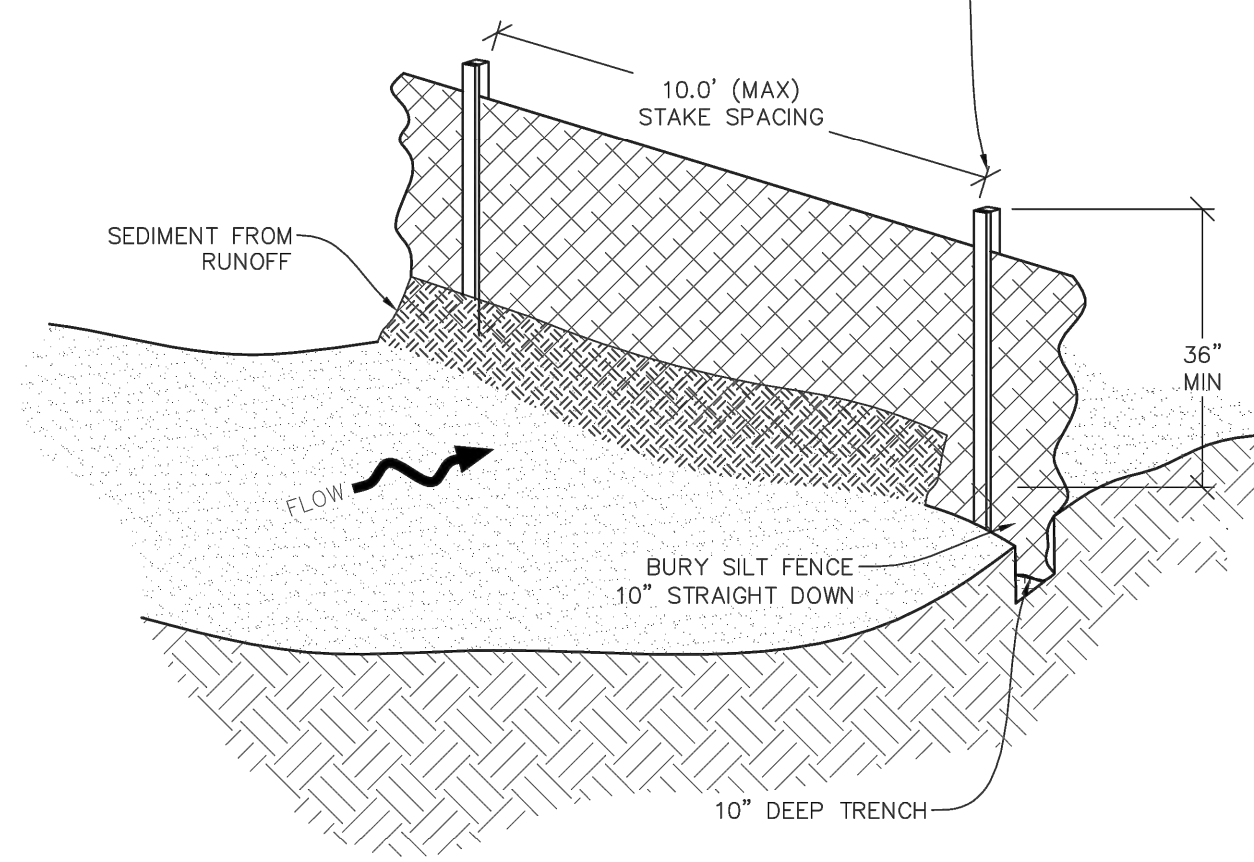

—X—X— SF SILT FENCE

**Town of Parker** COLORADO **CBMP** CONSTRUCTION BEST MANAGEMENT PRACTICES **SF** 1 OF 4 Oct. 2013

NO CHANGES ARE TO BE MADE TO THIS DRAWING WITHOUT WRITTEN PERMISSION OF THE TOWN OF PARKER.

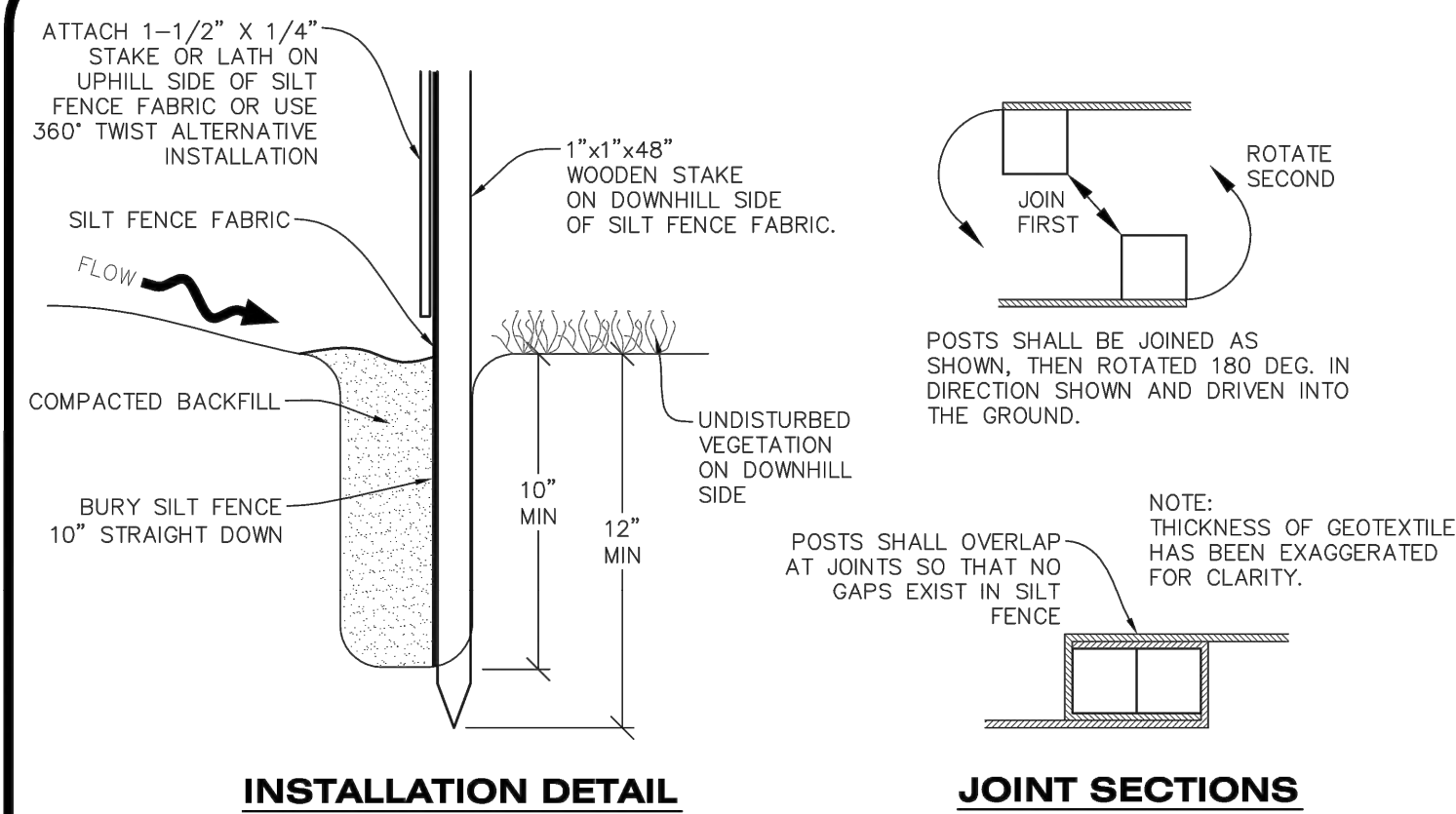

INSTALLATION DETAIL JOINT SECTIONS

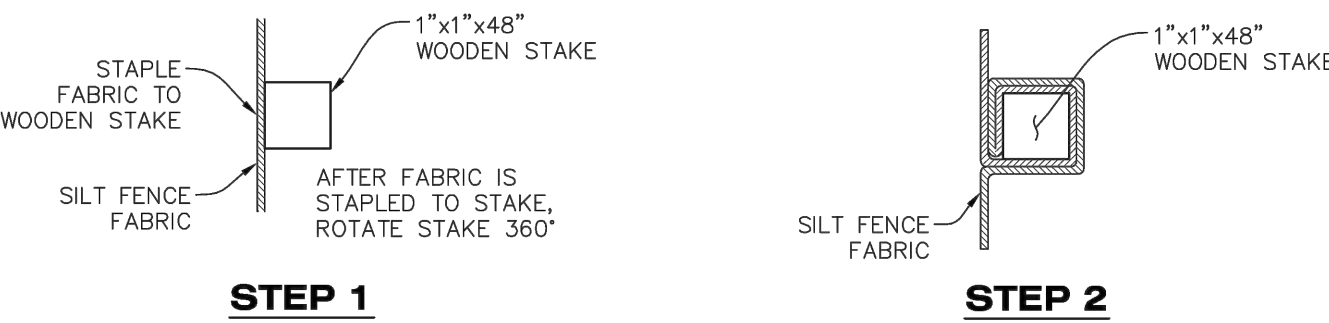

ALTERNATIVE INSTALLATION - 360° TWIST

—X—X— SF SILT FENCE

**Town of Parker** COLORADO **CBMP** CONSTRUCTION BEST MANAGEMENT PRACTICES **SF** 2 OF 4 Oct. 2013

NO CHANGES ARE TO BE MADE TO THIS DRAWING WITHOUT WRITTEN PERMISSION OF THE TOWN OF PARKER.

**SILT FENCE INSTALLATION NOTES**

- SEE CBMP PLAN FOR LOCATION(S) OF SILT FENCE.
- ALL SILT FENCE SHALL BE INSTALLED IN GOOD CONDITION AND FREE OF ANY DEFECTS INCLUDING RIPS, HOLES AND OBVIOUS WEAR.
- A UNIFORM 10" DEEP ANCHOR TRENCH SHALL BE EXCAVATED USING A TRENCHER.
- A 10" DEEP ANCHOR SLIT SHALL BE FORMED IF USING A STATIC SLICING METHOD.
- EXCAVATED MATERIAL SHALL BE PLACED ON THE UPHILL SIDE OF THE ANCHOR TRENCH.
- ANCHOR TRENCH SHALL BE GENERALLY FREE OF ROCKS OR OTHER DEBRIS PRIOR TO THE PLACEMENT OF THE SILT FENCE.
- THE ANCHOR TRENCH SHALL BE THOROUGHLY BACKFILLED WITH SOIL THAT IS GENERALLY FREE OF ROCKS AND DEBRIS.
- ALL EXCAVATED MATERIAL SHALL BE PLACED ON THE UP-GRADE SIDE OF THE SILT FENCE.
- STAKES SHALL BE POSITIONED ON THE DOWNHILL SIDE OF THE SILT FENCE FABRIC AND PLACED ON 10.0' CENTERS OR LESS. STAKES SHALL BE EMBEDDED A MINIMUM OF 12" INTO THE GROUND. A WOODEN LATH SHALL BE ATTACHED TO THE OPPOSING (UPHILL) SIDE OF THE STAKE FOR ADDED STRENGTH AND SUPPORT. THE LATH SHALL HAVE THE FOLLOWING DIMENSIONS: 1"x1/4"x24".
- SILT FENCE SHALL BE PULLED TIGHT AS IT IS ANCHORED TO THE STAKES. THERE SHOULD NOT BE SIGNIFICANT SAGGING ALONG ANY PORTION OF THE SILT FENCE AFTER IT HAS BEEN ANCHORED TO THE STAKES.
- SILT FENCE FABRIC SHALL BE ANCHORED TO THE STAKES AND LATHS USING STAPLES OR NAILS OF AN APPROXIMATE LENGTH. ENOUGH STAPLES AND NAILS SHOULD BE PLACED ALONG THE LATH TO ENSURE PROPER ATTACHMENT.
- SILT FENCE FABRIC SHALL MEET THE FOLLOWING MANDATORY REQUIREMENTS:

PROPERTIES	TEST METHOD	MANDATORY REQUIREMENTS
GRAB TENSILE STRENGTH	ASTM D 4632	> 124 LBS
MULLEN BURST STRENGTH	ASTM D 3786	> 300 PSI
PUNCTURE STRENGTH	ASTM D 4833	> 60 LBS
TRAPEZOID TEAR STRENGTH	ASTM D 4533	> 65 LBS
UV RESISTANCE	ASTM D 4355	> 80% AT 500 HOURS OF UV EXPOSURE
FLOW RATE	ASTM D 4491	> 10 GAL/MIN/FT2
- AN ORIGINAL PRODUCT SPECIFICATION SHEET FROM THE SILT FENCE MANUFACTURER SHALL BE MADE AVAILABLE AT THE REQUEST OF THE TOWN'S INSPECTOR. THE PRODUCT SPECIFICATION SHEET SHALL PROVIDE THE RESULTS FOR THE TEST METHODS ABOVE.
- SILT FENCE JOINTS SHALL BE CONNECTED ACCORDING TO THE ATTACHED DRAWING.
- SILT FENCE THAT IS INSTALLED BEHIND CURBS AND SIDEWALKS MUST BE DONE SO THAT NO MORE THAN A 2" GAP EXISTS BETWEEN CONCRETE AND THE SILT FENCE. EROSION CONTROL BLANKETING (ECB) BETWEEN THE GAP MAY BE REQUIRED IN INSTANCES WHERE THIS DOES NOT OCCUR.

**Town of Parker** COLORADO **CBMP** CONSTRUCTION BEST MANAGEMENT PRACTICES **SF** 3 OF 4 Oct. 2013

NO CHANGES ARE TO BE MADE TO THIS DRAWING WITHOUT WRITTEN PERMISSION OF THE TOWN OF PARKER.

**SILT FENCE INSPECTION AND MAINTENANCE NOTES**

- THE EROSION CONTROL SUPERVISOR SHALL REGULARLY INSPECT THE SILT FENCE.
- ACCUMULATED SEDIMENT SHALL BE REMOVED REGULARLY.
- SILT FENCE SHALL REMAIN IN PLACE AND PROPERLY MAINTAINED UNTIL VEGETATIVE COVER HAS REACHED A CONSISTENT DENSITY OF AT LEAST 70% OF FULL VEGETATIVE COVER AND EROSION AND SEDIMENTATION IS NO LONGER A POSSIBILITY AS DETERMINED BY THE TOWN'S INSPECTOR OR AS OTHERWISE DIRECTED BY THE TOWN'S INSPECTOR.
- SILT FENCE SHALL BE REPLACED WHEN THERE ARE ANY SIGNS OF WEAR AND/OR DAMAGE.
- WHEN THE SILT FENCE IS REMOVED, ANY DISTURBED AREAS ASSOCIATED WITH THE INSTALLATION, MAINTENANCE, AND/OR REMOVAL OF THE SILT FENCE MAY NEED TO BE ROUGHENED, SEEDED, MULCHED, AND CRIMPED PER THE TOWN'S SPECIFICATIONS (SEE DETAIL SMC).

**Town of Parker** COLORADO **CBMP** CONSTRUCTION BEST MANAGEMENT PRACTICES **SF** 4 OF 4 Oct. 2013

NO CHANGES ARE TO BE MADE TO THIS DRAWING WITHOUT WRITTEN PERMISSION OF THE TOWN OF PARKER.

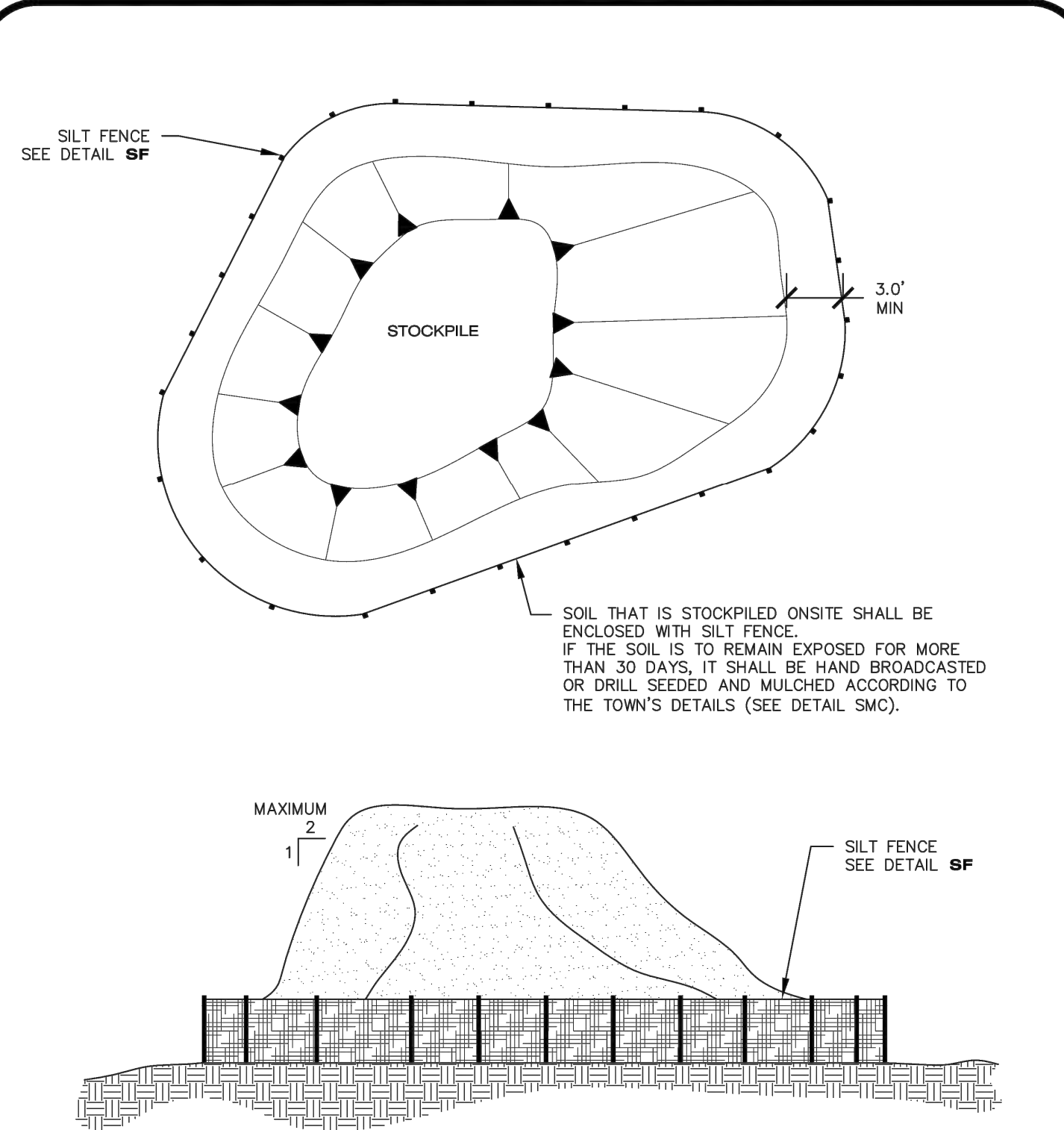

SP STOCKPILE PROTECTION

**Town of Parker** COLORADO **CBMP** CONSTRUCTION BEST MANAGEMENT PRACTICES **SP** JUNE 2006

To allow for a proper and timely establishment of native grasses, temporary irrigation is required over all areas where permanent native seeding is proposed. This includes, but is not limited to: detention ponds, drainageways, park and trail areas, general open space, etc. In addition to the landscape plans, please show the temporary irrigation symbol (TI) on the CBMP Plan over all areas where permanent native seeding is proposed. As a reminder, when working within Parker Water and Sanitation District's (PWSD) jurisdiction, the following is required:

- Temporary irrigation for native seed must be supplied by a fire hydrant hook-up. Use of proposed/existing landscape irrigation taps is not allowed. Please indicate on the irrigation plans fire hydrants that are to be used for the temporary irrigation mainline and provide a detail for the connection. This detail should show the hydrant, PRV, PWSD water meter, a 2" backflow assembly, a 2" x 2" cam lock for fire department quick disconnect and a support system for all components
- The following note must be shown on the Irrigation plan set "Temporary irrigation for establishment of native vegetation must be installed above ground, and removed immediately after establishment is complete, or in no case, any longer than one growing season." PWSD may allow temporary irrigation to continue for one additional growing season with prior approval.
- The following note must be shown on the Irrigation plan set "All temporary irrigation components including but not limited to mainlines, laterals, valves, heads and quick couplers must be installed above ground."
- All temporary irrigation components including but not limited to mainlines, laterals, valves, heads and quick couplers must be clearly labeled on the plans.
- Provide detail drawings for all above ground components including but not limited to mainlines, laterals, valves, heads and quick couplers.

If the project is outside of PWSD's jurisdiction, check with the applicable water provider regarding their specific requirements for temporary irrigation.



**CONSULTANTS:**  
**Matrix**  
 2435 RESEARCH PARKWAY, SUITE 300  
 COLORADO SPRINGS, CO 80920  
 PHONE: (719) 575-0100  
 FAX: (719) 575-0208  
**LAND DEVELOPMENT**  
 CONSULTANTS, LLC  
 950 S. CHERRY STREET, SUITE 512  
 DENVER, CO 80246  
**OWNER/DEVELOPER:**

**CIRCLE K**  
 ROCKY MOUNTAINS DIVISION  
 5500 S QUEBEC STREET, SUITE 100  
 GREENWOOD VILLAGE, CO 80111  
**SEAL**

FOR AND ON BEHALF OF MATRIX DESIGN GROUP, INC. CONTRACTOR IS RESPONSIBLE FOR OBTAINING THE MOST RECENT PROJECT CONSTRUCTION DOCUMENTS. MATRIX DESIGN GROUP IS NOT RESPONSIBLE FOR CHANGES, ALTERATIONS, OR USE OF CONSTRUCTION DOCUMENTS PRIOR TO JURISDICTIONAL APPROVAL.

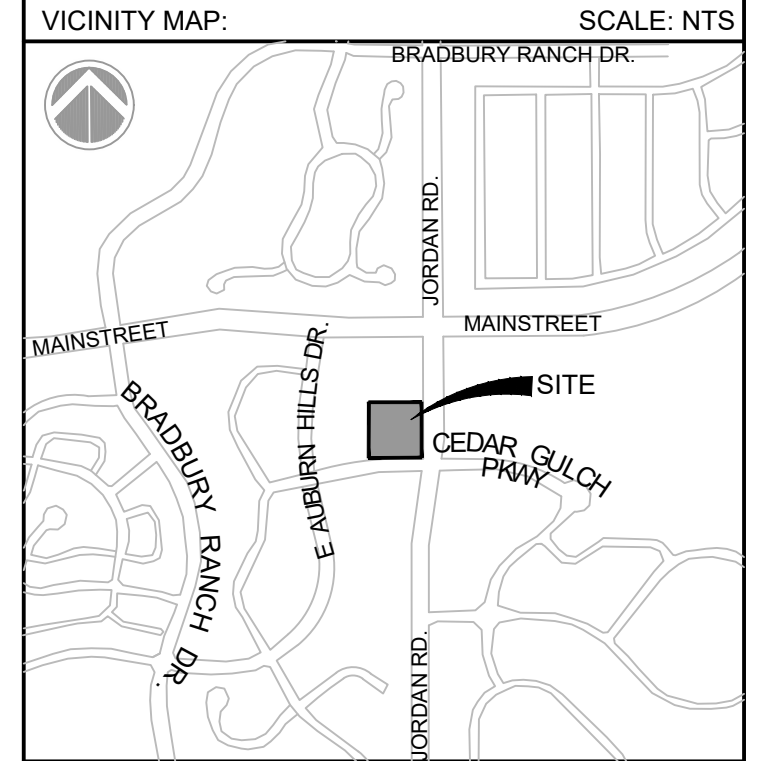

**PROJECT:**  
**CIRCLE K**  
**CONSTRUCTION DOCUMENTS**  
 16846 E AUBURN HILLS DRIVE  
 PARKER, CO 80134

REVISION HISTORY:

NO.	DATE	DESCRIPTION	BY

**DRAWING INFORMATION:**  
 PROJECT NO: 21.1207.030  
 DRAWN BY: RAD  
 CHECKED BY: NMS  
 DESIGNED BY: NMS  
**SHEET TITLE:**

**CBMP DETAILS**  
**C4.11**  
**SHEET 20 OF 26**  
 DATE: NOVEMBER 2022

NO CHANGES ARE TO BE MADE TO THIS DRAWING WITHOUT WRITTEN PERMISSION OF THE TOWN OF PARKER.

**SEEDING AND MULCHING SHALL BE PERFORMED ACCORDING TO THE ACCOMPANYING DETAIL(S) AND TEXT. NO EXCEPTIONS SHALL BE MADE**

- SEE PLAN VIEW FOR:
  - LOCATION(S) OF SEEDING AND MULCHING
  - TYPE OF SEED MIX
- SEED MIXES MAY CONFORM TO THE TABLE PROVIDED WITH THE SMC NOTES OR ALTERNATIVES MAY BE ALLOWED WITH PRIOR PERMISSION BY THE TOWN'S INSPECTOR.
- SEEDING MAY BE PERFORMED YEAR ROUND ASSUMING THE SOIL IS NOT FROZEN. SEEDING DURING TIMES OF EXTREME TEMPERATURES SHOULD BE AVOIDED IF POSSIBLE.
- AT THE BEGINNING OF THE LAND DISTURBANCE ACTIVITIES, IT IS HIGHLY RECOMMENDED THAT AN APPROPRIATE AMOUNT OF NATIVE TOPSOIL BE STRIPPED FROM THE SITE AND STOCKPILED. ALL AREAS, PRIOR TO PERMANENT SEEDING AND MULCHING, WILL LIKELY NEED TO BE COVERED WITH AN APPROPRIATE LAYER OF TOPSOIL. THIS REQUIREMENT APPLIES TO ALL AREAS WHERE NATIVE SEEDING IS SPECIFIED ON THE CBMP PLAN AND/OR LANDSCAPING PLANS.
- IT IS STRONGLY RECOMMENDED THAT SAMPLES FROM THE STRIPPED TOPSOIL BE PROPERLY COLLECTED AND TESTED BY A QUALIFIED LABORATORY TO ENSURE ADEQUATE NUTRIENT CONTENT PRIOR TO SEEDING AND MULCHING. IF IT IS DISCOVERED THAT THE TOPSOIL IS VOID OF THE NUTRIENTS NECESSARY TO SUCCESSFULLY ESTABLISH THE REQUIRED VEGETATION, THEN THE APPROPRIATE AMENDMENTS SHALL BE ADDED.
- ALL AREAS TO BE SEED AND MULCHED SHALL BE SURFACE ROUGHENED ACCORDING TO THE SURFACE ROUGHENING DETAILS AND NOTES. SURFACE ROUGHENING SHALL OCCUR AFTER PLACEMENT OF THE TOPSOIL.
- WHEN INSTALLED WITH A DRILL SEEDER, SEED SHALL BE PLACED AT A DEPTH OF 1/4 - 1/2 INCH. ROW SPACING SHALL BE NO MORE THAN 6-INCHES.
- ALL AREAS INCAPABLE OF BEING DRILL SEEDER SHALL BE SURFACE ROUGHENED ACCORDING TO THE SURFACE ROUGHENING NOTES OR EFFECTIVELY ROUGHENED USING A HARROW OR OTHER SUCH IMPLEMENT. ALL AREAS SHALL BE UNIFORMLY HAND BROADCASTED WITH THE PROPER SEED MIX APPLIED AT TWO TIMES THE DRILL SEEDER RATE. BROADCASTED AREAS SHALL THEN BE RE-HARROWED OR RE-RAKED USING A HARD-TIPPED RAKE TO ENSURE THAT SEEDS ARE BURIED TO AN APPROXIMATE DEPTH OF 1/4 - 1/2 INCH.
- AFTER SEEDING HAS BEEN COMPLETED, MULCH SHALL BE UNIFORMLY APPLIED AT A RATE OF 2 TONS/ACRE (4,000 LBS/ACRE). MULCH SHALL BE MECHANICALLY CRIMPED TO A DEPTH OF 2 INCHES USING A CRIMPER. MULCH SHALL BE HAND CRIMPED AND COVERED WITH A TACKIFIER IN AREAS WHERE MECHANICAL CRIMPING IS NOT POSSIBLE. WHEN SOILS PERMIT, ALL MULCH SHALL BE CRIMPED SUCH THAT THE INDIVIDUAL PIECES OF STRAW OR HAY FORM EXAGGERATED V-SHAPES PROTRUDING OUT OF THE GROUND SEVERAL INCHES.
- IN CERTAIN INSTANCES, IT MAY BE NECESSARY TO APPLY A TACKIFIER IN ORDER TO HELP WITH STRAW DISPLACEMENT. TACKIFIER SHALL BE APPLIED ACCORDING TO THE MANUFACTURER'S SPECIFICATIONS.

NO CHANGES ARE TO BE MADE TO THIS DRAWING WITHOUT WRITTEN PERMISSION OF THE TOWN OF PARKER.

**SEEDING AND MULCHING MAINTENANCE NOTES**

- THE EROSION CONTROL SUPERVISOR SHALL REGULARLY INSPECT THE SEEDING AND MULCHING.
- ANY SEEDED AND MULCHED AREAS THAT BECOME DAMAGED SHALL BE REPAIRED WITHIN THE TIME FRAME SPECIFIED BY THE TOWN'S INSPECTOR.

**WEED MANAGEMENT**

- ALL HERBICIDES SHALL BE APPLIED BY COMMERCIAL PESTICIDE APPLICATORS LICENSED BY THE COLORADO DEPARTMENT OF AGRICULTURE AS QUALIFIED APPLICATORS. THE CONTRACTOR SHALL FURNISH DOCUMENTATION OF SUCH LICENSING PRIOR TO HERBICIDE APPLICATION.
- HERBICIDE APPLICATION METHOD SHALL BE SUCH THAT PLANT GROWTH OUTSIDE THE DESIGNATED TREATMENT AREAS WILL NOT BE DAMAGED. ALL DAMAGE CAUSED BY IMPROPER HERBICIDE APPLICATION SHALL BE REPAIRED AT THE CONTRACTOR'S EXPENSE.
- HERBICIDES SHALL BE APPLIED DURING THE APPROPRIATE SEASONS, WHEN TARGET PLANTS ARE ACTIVELY GROWING.
- AFTER THE GRASS SEED IS ESTABLISHED, APPROPRIATE HERBICIDES SHALL BE APPLIED TO CONTROL THE REMAINING WEEDS TO ENSURE A TIMELY RETURN OF THE FINANCIAL SECURITY. PROPER TIMING OF HERBICIDE APPLICATIONS ARE NECESSARY TO ACHIEVE THE SUPPRESSION OF WEED SEED PRODUCTION AND DEPLETION OF WEED ROOT MASS. ULTIMATELY, THE HERBICIDES USED SHALL BE BASED UPON THE TARGET WEEDS.
- HERBICIDE TREATMENTS SHALL CONTINUE AT AN APPROPRIATE RATE UNTIL IT IS EVIDENT THAT WEED GROWTH PRESENCE AND GROWTH IS MINIMAL AND MAY BE CONTROLLED THROUGH MOWING AND/OR ANNUAL HERBICIDE TREATMENT.

NO CHANGES ARE TO BE MADE TO THIS DRAWING WITHOUT WRITTEN PERMISSION OF THE TOWN OF PARKER.

**TOWN OF PARKER, SEED MIX 1**

- 20% CANADA WILDRYE
- 15% CRESTED WHEATGRASS
- 15% SLENDER WHEATGRASS
- 10% ANNUAL RYEGRASS
- 10% SHEEP FESCUE
- 10% BIG BLUESTEM
- 10% SIDEOTS GRAMA
- 5% CANADA BLUEGRASS
- 5% BLUE GRAMA

**SEEDING RATE:**

- DRILLED: 25 LBS/ACRE
- BROADCAST: 50 LBS/ACRE

**TOWN OF PARKER, SEED MIX 2**

- 22% SLENDER WHEATGRASS
- 18% SODAR STREAMBANK WHEATGRASS
- 13% ARIZONA FESCUE
- 13% BLUE GRAMA
- 12% PERENNIAL RYEGRASS
- 12% BARLEY OR OATS
- 5% SPIKE MUHLY
- 5% INDIAN RICEGRASS

**SEEDING RATE:**

- DRILLED: 25 LBS/ACRE
- BROADCAST: 50 LBS/ACRE

**TOWN OF PARKER, SEED MIX 3 (LOW-GROWTH MIX)**

- 25% EPHRAIM CRESTED WHEATGRASS
- 23% SHEEP FESCUE
- 18% PERENNIAL RYEGRASS
- 13% CANADA BLUEGRASS
- 12% BARLEY OR OATS
- 9% BLUE FESCUE

**SEEDING RATE:**

- DRILLED: 25 LBS/ACRE
- BROADCAST: 50 LBS/ACRE

**SEED MIX 4:**

OTHER SEED MIXES APPROVED BY THE TOWN OF PARKER

**CBMP** SMC  
CONSTRUCTION BEST MANAGEMENT PRACTICES 1 OF 3  
Oct. 2013

**CBMP** SMC  
CONSTRUCTION BEST MANAGEMENT PRACTICES 2 OF 3  
Oct. 2013

**CBMP** SMC  
CONSTRUCTION BEST MANAGEMENT PRACTICES 3 OF 3  
Oct. 2013

NO CHANGES ARE TO BE MADE TO THIS DRAWING WITHOUT WRITTEN PERMISSION OF THE TOWN OF PARKER.

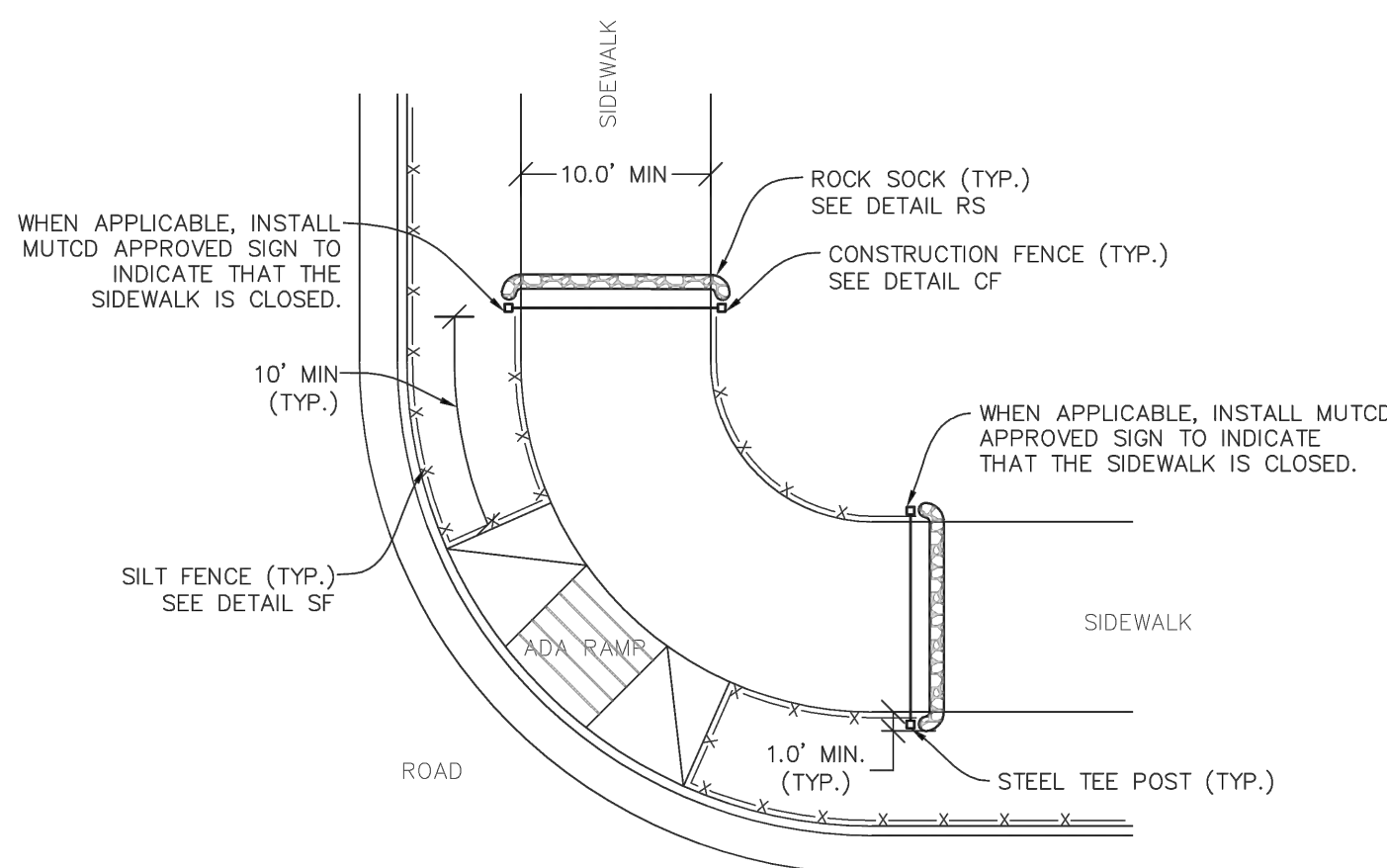

NOTE: SEDIMENT CONTROL LOGS (SCL) MAY BE USED IN LIEU OF SILT FENCE (SF) WITH PRIOR APPROVAL FROM TOWN.

**STP** **SIDEWALK TRANSITION PROTECTION (AT INTERSECTION)**

**CBMP** STP  
CONSTRUCTION BEST MANAGEMENT PRACTICES 1 OF 3  
Oct. 2013

NO CHANGES ARE TO BE MADE TO THIS DRAWING WITHOUT WRITTEN PERMISSION OF THE TOWN OF PARKER.

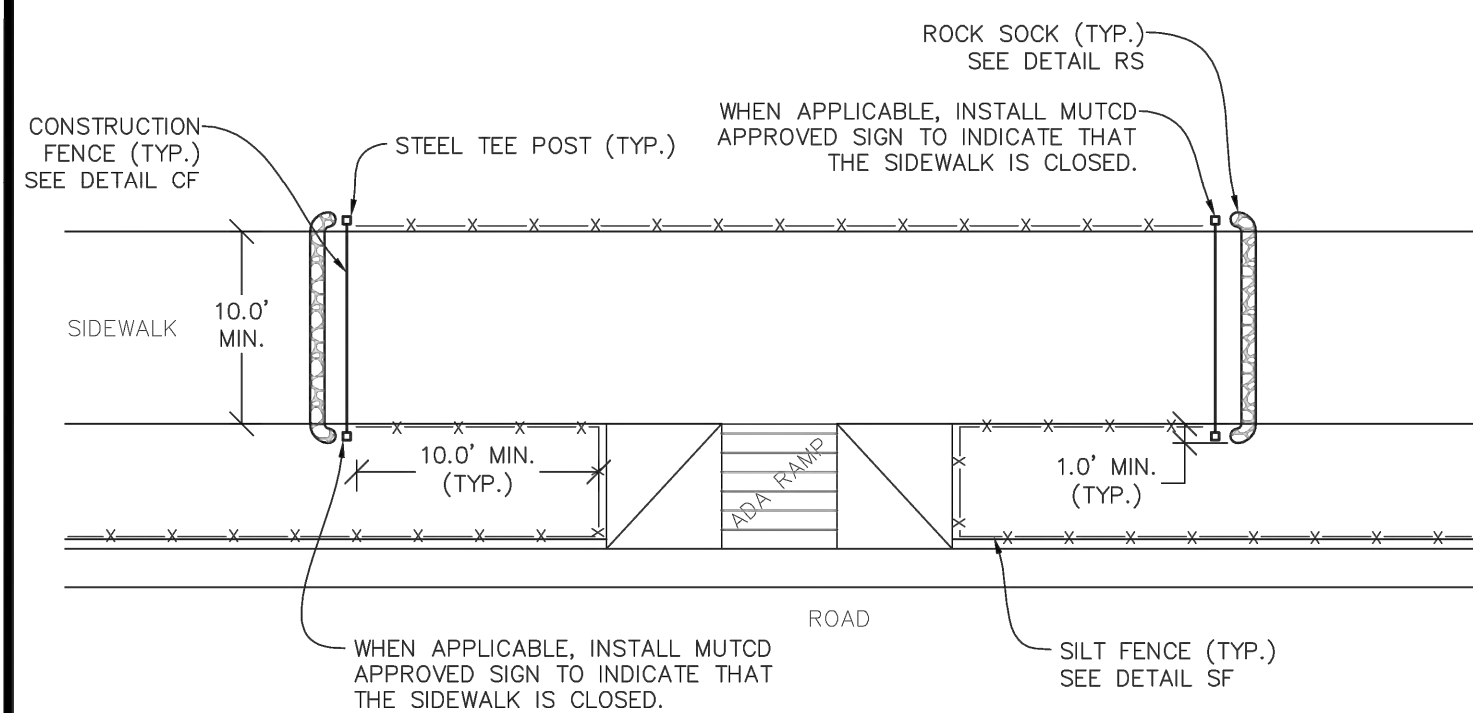

NOTE: SEDIMENT CONTROL LOGS (SCL) MAY BE USED IN LIEU OF SILT FENCE (SF) WITH PRIOR APPROVAL FROM TOWN.

**STP** **SIDEWALK TRANSITION PROTECTION (ALONG STRAIGHT ROADWAY)**

**CBMP** STP  
CONSTRUCTION BEST MANAGEMENT PRACTICES 2 OF 3  
Oct. 2013

NO CHANGES ARE TO BE MADE TO THIS DRAWING WITHOUT WRITTEN PERMISSION OF THE TOWN OF PARKER.

**SIDEWALK TRANSITION PROTECTION INSTALLATION NOTES**

- SEE PLAN VIEW FOR LOCATION(S) OF SIDEWALK TRANSITION PROTECTION.
- ROCK SOCK SHALL BE CONSTRUCTED ACCORDING TO THE DETAIL (SEE DETAIL RS).
- SILT FENCE SHALL BE CONSTRUCTED ACCORDING TO THE DETAIL (SEE DETAIL SF).
- CONSTRUCTION FENCE SHALL BE CONSTRUCTED ACCORDING TO THE DETAIL (SEE DETAIL CF).
- SEDIMENT CONTROL LOGS MAY BE USED IN LIEU OF SILT FENCE WITH PRIOR APPROVAL FROM THE TOWN.

**SIDEWALK TRANSITION PROTECTION INSPECTION & MAINTENANCE NOTES**

- THE EROSION CONTROL SUPERVISOR SHALL REGULARLY INSPECT THE SIDEWALK TRANSITION INSPECTION.

**CBMP** STP  
CONSTRUCTION BEST MANAGEMENT PRACTICES 3 OF 3  
Oct. 2013



**Matrix**  
2435 RESEARCH PARKWAY, SUITE 300  
COLORADO SPRINGS, CO 80920  
PHONE: (719) 575-0100  
FAX: (719) 575-0208

**LAND DEVELOPMENT**  
CONSULTANTS, LLC  
950 S. CHERRY STREET, SUITE 512  
DENVER, CO 80246

**CIRCLE K**

ROCKY MOUNTAINS DIVISION  
5500 S QUEBEC STREET, SUITE 100  
GREENWOOD VILLAGE, CO 80111



FOR AND ON BEHALF OF MATRIX DESIGN GROUP, INC  
CONTRACTOR IS RESPONSIBLE FOR OBTAINING THE MOST RECENT PROJECT CONSTRUCTION DOCUMENTS.  
MATRIX DESIGN GROUP IS NOT RESPONSIBLE FOR CHANGES, ALTERATIONS, OR USE OF CONSTRUCTION DOCUMENTS PRIOR TO JURISDICTIONAL APPROVAL.

VICINITY MAP: SCALE: NTS

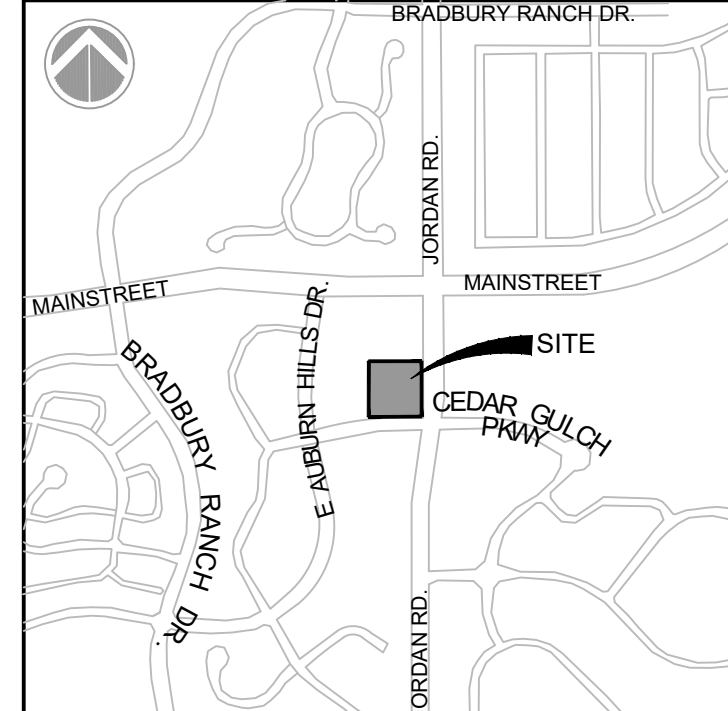

PROJECT: **CIRCLE K**  
**CONSTRUCTION DOCUMENTS**  
16846 E AUBURN HILLS DRIVE  
PARKER, CO 80134

REVISION HISTORY:			
NO.	DATE	DESCRIPTION	BY

DRAWING INFORMATION:  
PROJECT NO: 21.1207.030  
DRAWN BY: RAD  
CHECKED BY: NMS  
DESIGNED BY: NMS

**CBMP DETAILS**

**C4.12**  
SHEET 21 OF 26

DATE: NOVEMBER 2022

FILE LOCATION: S:\CIRCLE K\AUBURN & JORDAN\1100 DIVISION PLAN SETS\CONSTRUCTION PLANS\CBMP\STP.DWG



CONSULTANTS:  
**Matrix**  
 2435 RESEARCH PARKWAY, SUITE 300  
 COLORADO SPRINGS, CO 80920  
 PHONE: (719) 575-0100  
 FAX: (719) 575-0208  
**LAND DEVELOPMENT**  
 CONSULTANTS, LLC  
 950 S. CHERRY STREET, SUITE 512  
 DENVER, CO 80246  
 OWNER/DEVELOPER:



SEAL  
**PROFESSIONAL ENGINEER**  
 FOR AND ON BEHALF OF MATRIX DESIGN GROUP, INC. CONTRACTOR IS RESPONSIBLE FOR OBTAINING THE MOST RECENT PROJECT CONSTRUCTION DOCUMENTS. MATRIX DESIGN GROUP IS NOT RESPONSIBLE FOR CHANGES, ALTERATIONS, OR USE OF CONSTRUCTION DOCUMENTS PRIOR TO JURISDICTIONAL APPROVAL.

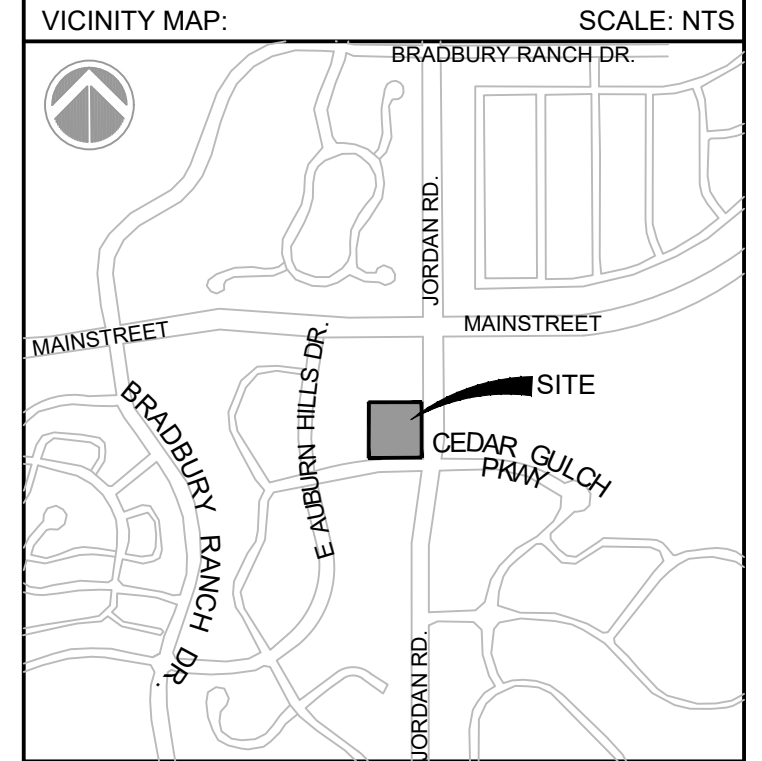

PROJECT:  
**CIRCLE K**  
**CONSTRUCTION DOCUMENTS**  
 16846 E AUBURN HILLS DRIVE  
 PARKER, CO 80134

REVISION HISTORY:

NO.	DATE	DESCRIPTION	BY

DRAWING INFORMATION:  
 PROJECT NO: 21.1207.030  
 DRAWN BY: RAD  
 CHECKED BY: NMS  
 DESIGNED BY: NMS  
 SHEET TITLE:

**CBMP DETAILS**

**C4.13**  
 SHEET 22 OF 26  
 DATE: NOVEMBER 2022

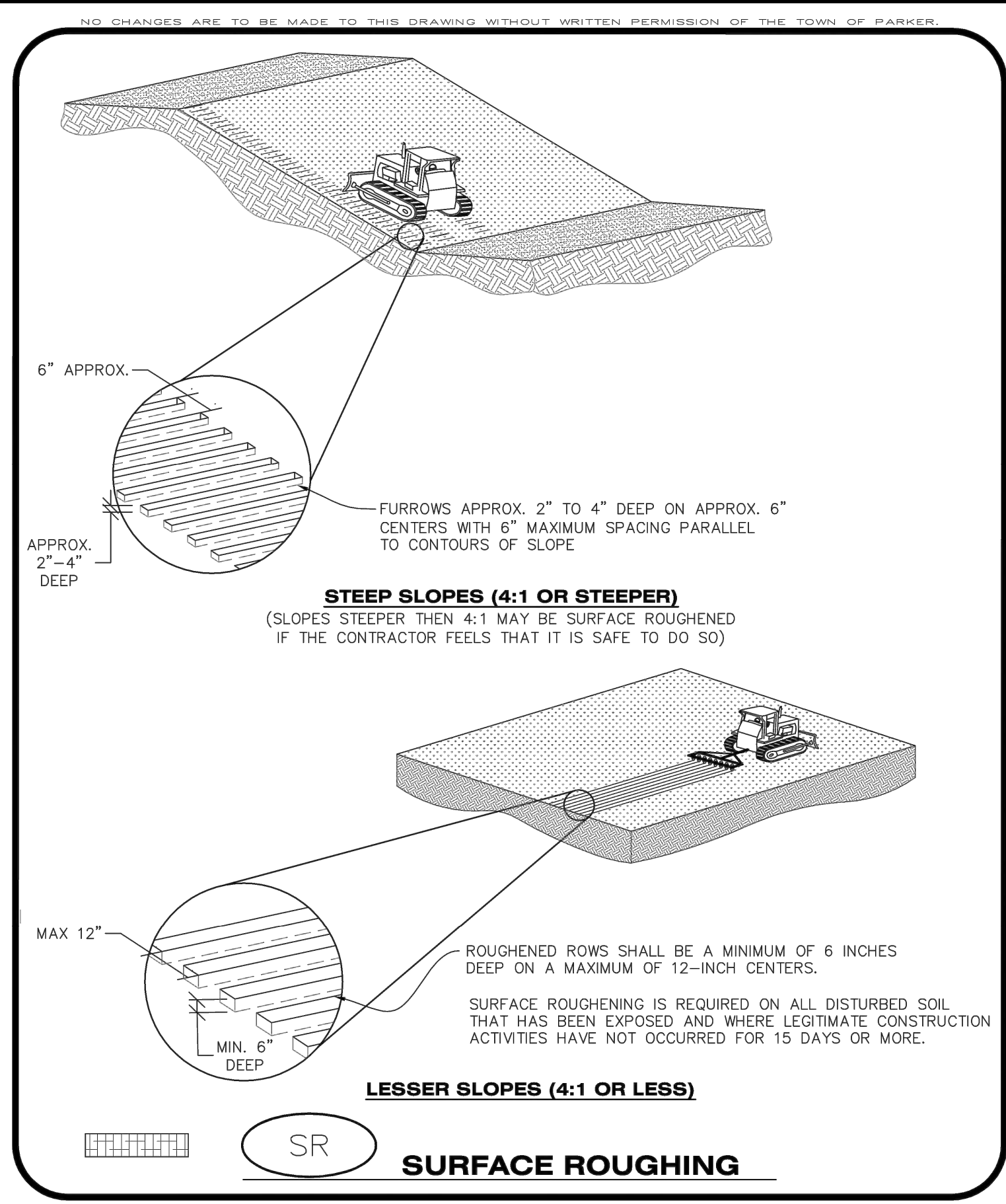

**CBMP** | **SR**  
 CONSTRUCTION BEST MANAGEMENT PRACTICES | 1 OF 2  
 Oct. 2013

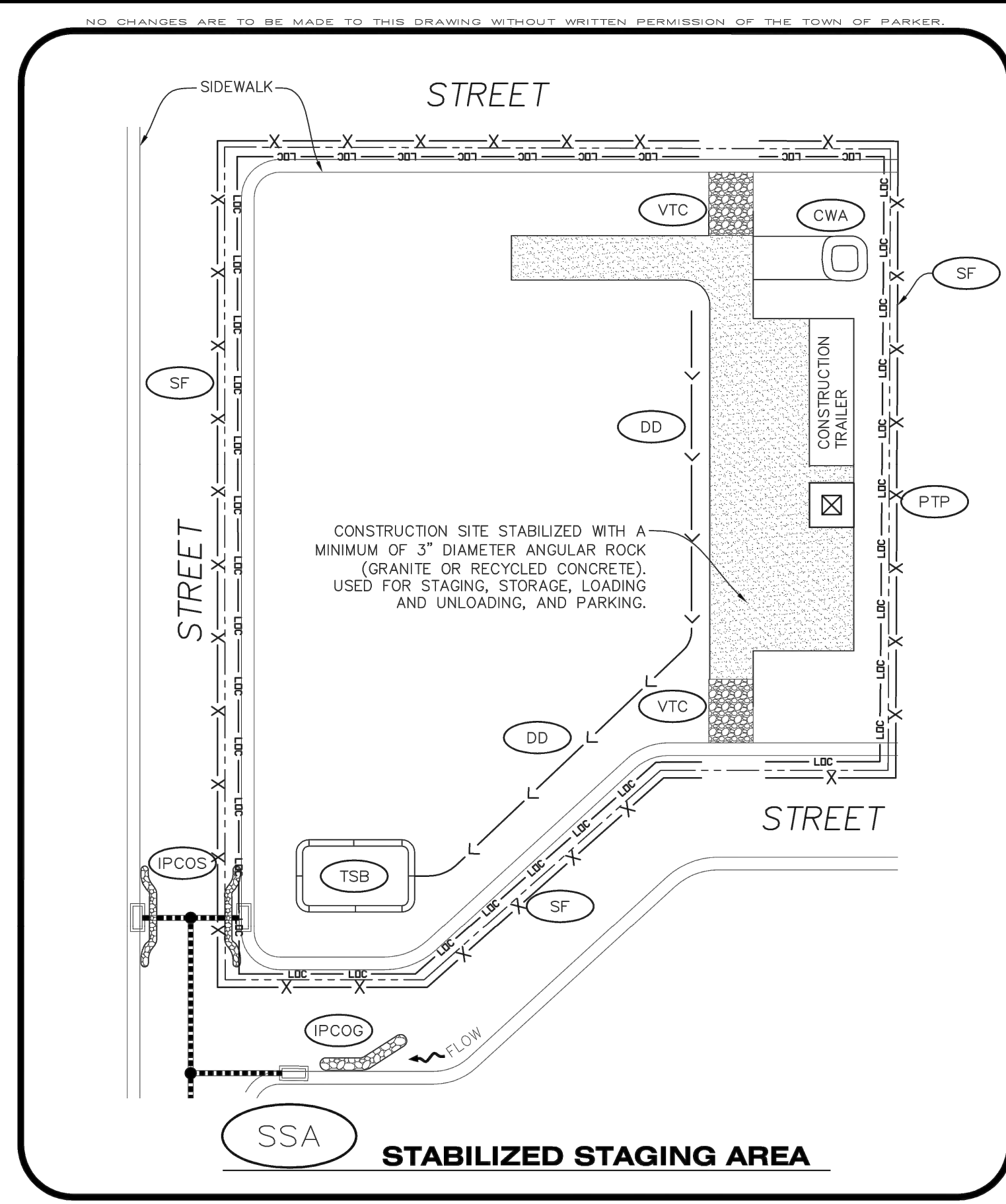

**CBMP** | **SSA**  
 CONSTRUCTION BEST MANAGEMENT PRACTICES | 1 OF 2  
 Oct. 2013

NO CHANGES ARE TO BE MADE TO THIS DRAWING WITHOUT WRITTEN PERMISSION OF THE TOWN OF PARKER.

**SURFACE ROUGHENING INSTALLATION NOTES**

- SEE CBMP PLAN FOR LOCATION(S) OF SURFACE ROUGHENING.
- DISTURBED AREAS THAT REMAIN INACTIVE FOR 15 DAYS OR MORE MUST RECEIVE SURFACE ROUGHENING OR ANOTHER APPROVED BMP FROM THE SDECM. DETERMINATION OF JOB SITE INACTIVITY IS AT THE DISCRETION OF THE TOWN'S INSPECTOR.
- FOR STEEP SLOPES (3:1 OR STEEPER), IT IS ACCEPTABLE TO "TRACK" THE SLOPES, ACCORDING TO THE CBMP DETAILS.
- SCHEDULES FOR REQUIRING STABILIZATION MAY BE MODIFIED BY THE PERMITTEE TO ALLOW FOR SPECIAL CONSIDERATIONS SUCH AS STABILIZING ACCESS AREAS AND AREAS IN CLOSE PROXIMITY TO CONTINUING CONSTRUCTION.

**SURFACE ROUGHENING INSPECTION AND MAINTENANCE NOTES**

- THE EROSION CONTROL SUPERVISOR SHALL PROACTIVELY INSPECT THE SURFACE ROUGHENING.

**CBMP** | **SR**  
 CONSTRUCTION BEST MANAGEMENT PRACTICES | 2 OF 2  
 Oct. 2013

NO CHANGES ARE TO BE MADE TO THIS DRAWING WITHOUT WRITTEN PERMISSION OF THE TOWN OF PARKER.

**STABILIZED STAGING AREA INSTALLATION NOTES**

- SEE CBMP PLAN FOR LOCATION OF STAGING AREA. CONTRACTOR MAY MODIFY LOCATION AND SIZE OF STABILIZED STAGING AREA WITH TOWN APPROVAL.
- STABILIZED STAGING AREA SHALL BE LARGE ENOUGH TO FULLY CONTAIN PARKING, STORAGE, AND LOADING OPERATIONS.
- THE STABILIZED STAGING AREA SHALL CONSIST OF A MINIMUM OF 3" DIAMETER OF ANGULAR ROCK (GRANITE OR RECYCLED CONCRETE).
- SSA FOR SMALLER SITES MAY NOT BE PRACTICAL. IN THESE AND SIMILAR SITUATIONS, VARIANCES MAY BE PERMITTED BY THE TOWN.

**STABILIZED STAGING AREA INSPECTION AND MAINTENANCE NOTES**

- THE EROSION CONTROL SUPERVISOR SHALL REGULARLY INSPECT THE STAGING AREA.
- STABILIZED STAGING AREA SHALL BE ENLARGED AS NECESSARY TO CONTAIN PARKING, STORAGE, LOADING, AND UNLOADING.

**CBMP** | **SSA**  
 CONSTRUCTION BEST MANAGEMENT PRACTICES | 2 OF 2  
 Oct. 2013

FILE LOCATION: S:\CIRCLE K\MAIN & JORDAN\100 DIV\104 PLAN SETS\CONSTRUCTION PLANS\CBMP.DWG



2435 RESEARCH PARKWAY, SUITE 300  
COLORADO SPRINGS, CO 80920  
PHONE: (719) 575-0100  
FAX: (719) 575-0208



LAND DEVELOPMENT  
CONSULTANTS, LLC

950 S. CHERRY STREET, SUITE 512  
DENVER, CO 80246

OWNER/DEVELOPER:



ROCKY MOUNTAINS DIVISION  
5500 S QUEBEC STREET, SUITE 100  
GREENWOOD VILLAGE, CO 80111

SEAL



FOR AND ON BEHALF OF MATRIX DESIGN GROUP, INC  
CONTRACTOR IS RESPONSIBLE FOR OBTAINING THE  
MOST RECENT PROJECT CONSTRUCTION DOCUMENTS.  
MATRIX DESIGN GROUP IS NOT RESPONSIBLE FOR  
CHANGES, ALTERATIONS, OR USE OF CONSTRUCTION  
DOCUMENTS PRIOR TO JURISDICTIONAL APPROVAL.

VICINITY MAP: SCALE: NTS

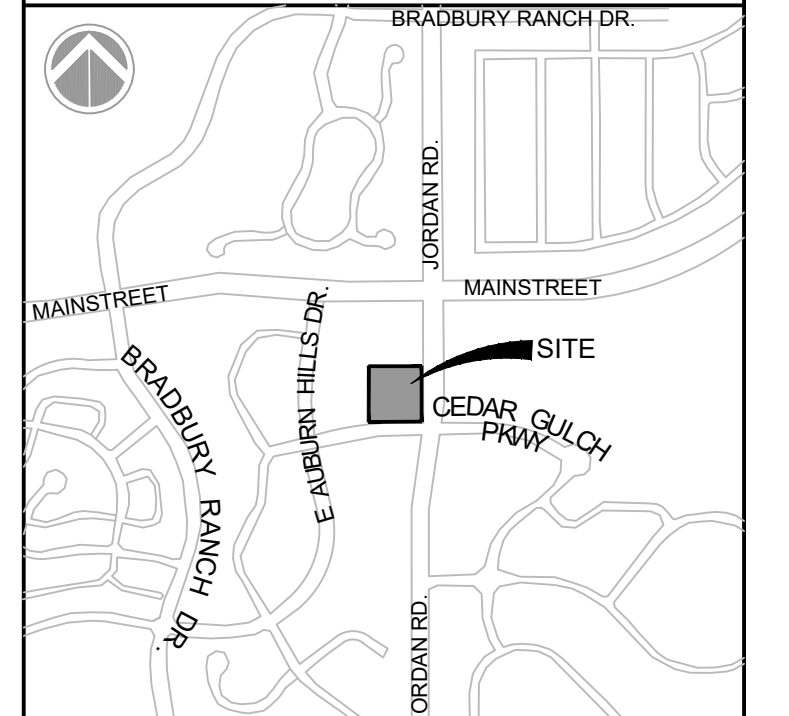

PROJECT:

CIRCLE K

CONSTRUCTION DOCUMENTS

16846 E AUBURN HILLS DRIVE  
PARKER, CO 80134

REVISION HISTORY:

NO.	DATE	DESCRIPTION	BY

DRAWING INFORMATION:

PROJECT NO: 21.1207.030

DRAWN BY: RAD

CHECKED BY: NMS

DESIGNED BY: NMS

SHEET TITLE:

CBMP DETAILS

C4.14

SHEET 23 OF 26

DATE: NOVEMBER 2022

CONSULTANTS:

**TEMPORARY SEDIMENT BASIN INSTALLATION NOTES**

- SEE CBMP PLAN FOR LOCATION(S) OF SEDIMENT BASIN(S).
- THE TEMPORARY SEDIMENT BASIN(S) SHALL BE INSTALLED AND FUNCTIONING PRIOR TO ANY OTHER GRADING ACTIVITIES.
- THE EXACT DIMENSIONS AND DETAILS OF THE TEMPORARY SEDIMENT BASIN SHALL BE DETERMINED BY THE DESIGN ENGINEER, IN ACCORDANCE WITH UDFCD VOLUME 3, AS AMENDED.
- EMBANKMENT MATERIAL SHALL CONSIST OF SOIL FREE OF DEBRIS, ORGANIC MATERIAL, AND ROCKS OR CONCRETE GREATER THAN 3" AND SHALL HAVE A MINIMUM OF 15% BY WEIGHT PASSING THE NO. 200 SIEVE.
- EMBANKMENT MATERIAL SHALL BE COMPACTED TO A MINIMUM OF 95% DENSITY, AND WITHIN +/- 2% OF OPTIMUM MOISTURE IN ACCORDANCE WITH ASTM D698.
- AN APPROPRIATELY SIZED DEWATERING BAG SHALL BE SECURED TO THE END OF THE DISCHARGE PIPE. THE DEWATERING BAG SHALL BE REPLACED ONCE SEDIMENT ACCUMULATION REACHES 50%.

**TEMPORARY SEDIMENT BASIN INSPECTION AND MAINTENANCE NOTES**

- THE EROSION CONTROL SUPERVISOR SHALL REGULARLY INSPECT THE TEMPORARY SEDIMENT BASIN.
- ACCUMULATED SEDIMENT SHALL BE REMOVED WHEN THE SEDIMENT REACHES A DEPTH OF 2.0', OR WITHIN 2.0' OF THE SPILLWAY CREST, OR AS OTHERWISE DIRECTED BY THE TOWN'S INSPECTOR.
- SEDIMENT BASINS SHALL REMAIN IN PLACE AND PROPERLY MAINTAINED UNTIL UPSTREAM VEGETATIVE COVER HAS REACHED A CONSISTENT DENSITY OF AT LEAST 70% OF FULL VEGETATIVE COVER AND EROSION AND SEDIMENTATION IS NO LONGER A POSSIBILITY AS DETERMINED BY THE TOWN'S INSPECTOR.

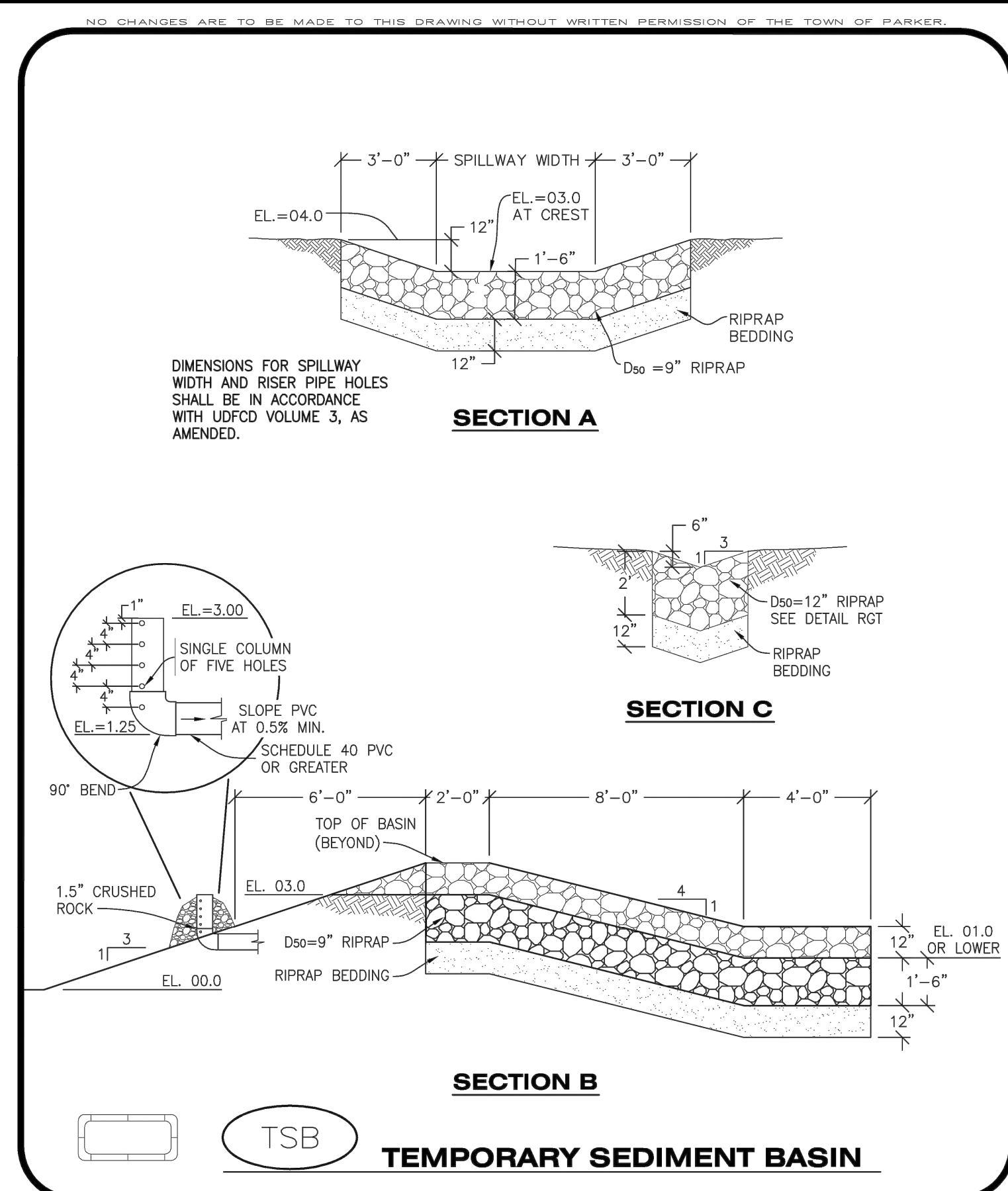

**TSB**      **CBMP**      **TSB**  
CONSTRUCTION BEST MANAGEMENT PRACTICES      2 OF 3  
Oct. 2013

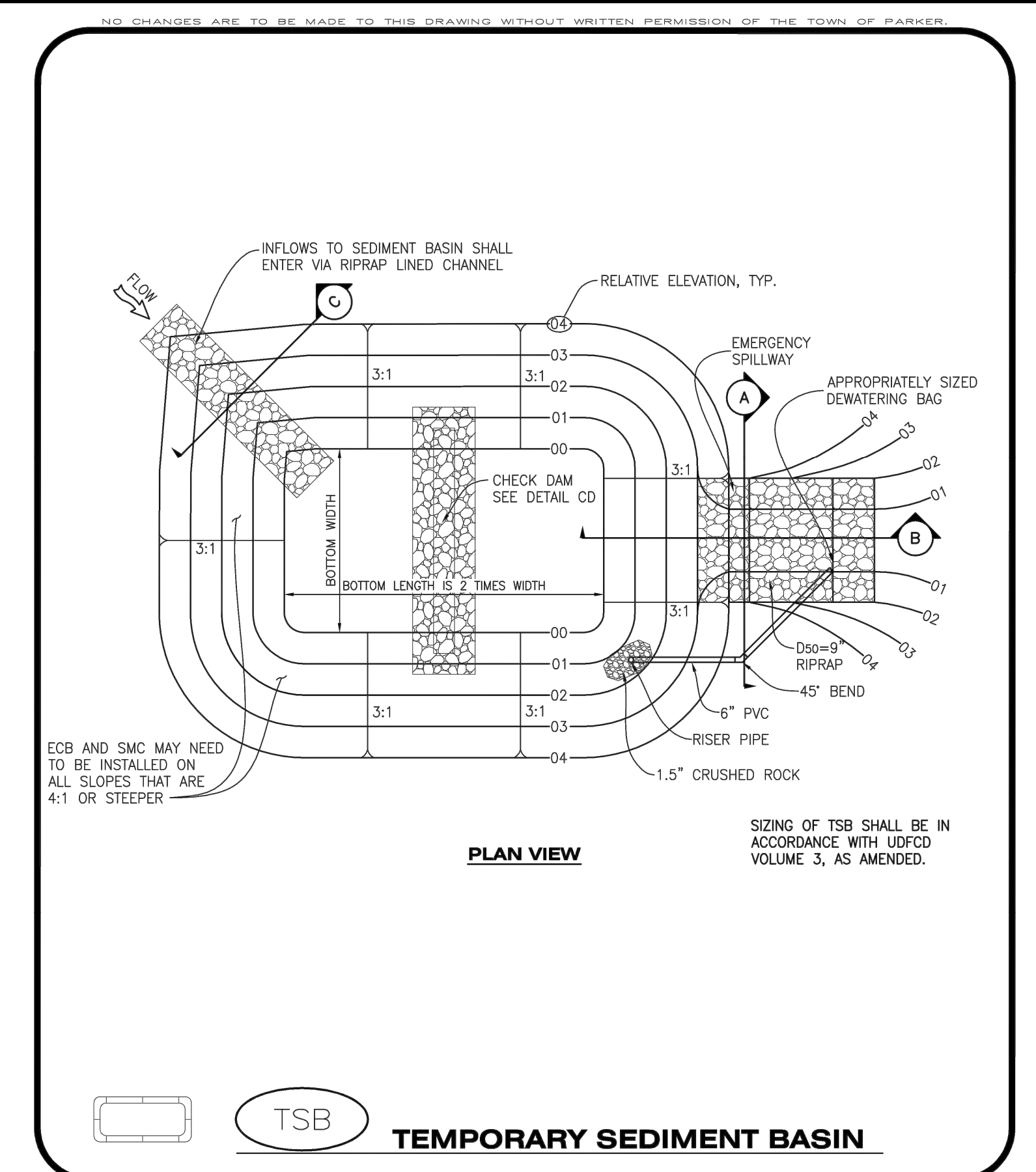

**TSB**      **CBMP**      **TSB**  
CONSTRUCTION BEST MANAGEMENT PRACTICES      1 OF 3  
Oct. 2013

**VEHICLE TRACKING CONTROL PAD INSTALLATION NOTES**

- SEE CBMP PLAN FOR LOCATION(S) OF VEHICLE TRACKING CONTROL PAD(S).
- ALL CONSTRUCTION TRAFFIC MUST ENTER AND EXIT THE SITE THROUGH THE APPROVED ACCESS POINT(S). A VEHICLE TRACKING CONTROL PAD IS REQUIRED AT ALL APPROVED ACCESS POINTS TO THE SITE. EXCEPTIONS MAY BE CONSIDERED FOR CONSTRUCTION ACTIVITY OCCURRING IMMEDIATELY ADJACENT TO PAVED AREAS AND WHERE ALTERNATIVE BMP'S ARE IMPLEMENTED. SUCH ACTIVITY MAY INCLUDE, BUT NOT BE LIMITED TO RESIDENTIAL CONSTRUCTION, UTILITY CONSTRUCTION, ETC.
- THE VEHICLE TRACKING CONTROL PAD(S) INDICATED ON CBMP PLAN SHALL BE INSTALLED PRIOR TO ANY LAND DISTURBING ACTIVITIES.
- VEHICLE TRACKING CONTROL PADS SHALL BE A MINIMUM OF 50-FOOT LONG AND 10-FOOT WIDE, UNLESS A VARIANCE HAS BEEN GRANTED BY THE TOWN'S INSPECTOR.
- A BIAXIAL GEO-GRID SHALL BE PLACED UNDER THE VEHICLE TRACKING CONTROL PAD PRIOR TO THE PLACEMENT OF ROCK. THE AREA SHALL BE FREE FROM ANY VOIDS, ROCKS AND DEBRIS. THE BIAXIAL GEO-GRID SHALL BE TENSAR BX1100, MIRAFI BASXGRID II, OR AN APPROVED EQUAL. GEO-GRID SHALL BE PLACED, AND APPROPRIATELY OVERLAPPED IF NECESSARY, TO COVER THE ENTIRE LENGTH AND WIDTH OF THE VEHICLE TRACKING CONTROL PAD.
- CRUSHED ROCK SHALL BE A MINIMUM OF 3-6" GRANITE WITH A FRACTURED FACE (ALL SIDES).

**VEHICLE TRACKING CONTROL PAD INSTALLATION AND MAINTENANCE NOTES**

- THE EROSION CONTROL SUPERVISOR SHALL REGULARLY INSPECT THE VEHICLE TRACKING CONTROL PAD.
- WHEN THE VEHICLE TRACKING CONTROL PAD IS REMOVED, ANY DISTURBED AREAS ASSOCIATED WITH THE INSTALLATION, MAINTENANCE, AND/OR REMOVAL OF THE VEHICLE TRACKING CONTROL PAD SHALL BE ROUGHENED, SEEDED, MULCHED, AND CRIMPED PER THE TOWN'S SPECIFICATIONS (SEE DETAIL SMC).
- THE VEHICLE TRACKING CONTROL PAD SHALL BE MAINTAINED SUCH THAT THE ROCK REMAINS RELATIVELY LOOSE AND ACCUMULATED MUD AND OTHER DEBRIS IS REGULARLY REMOVED.

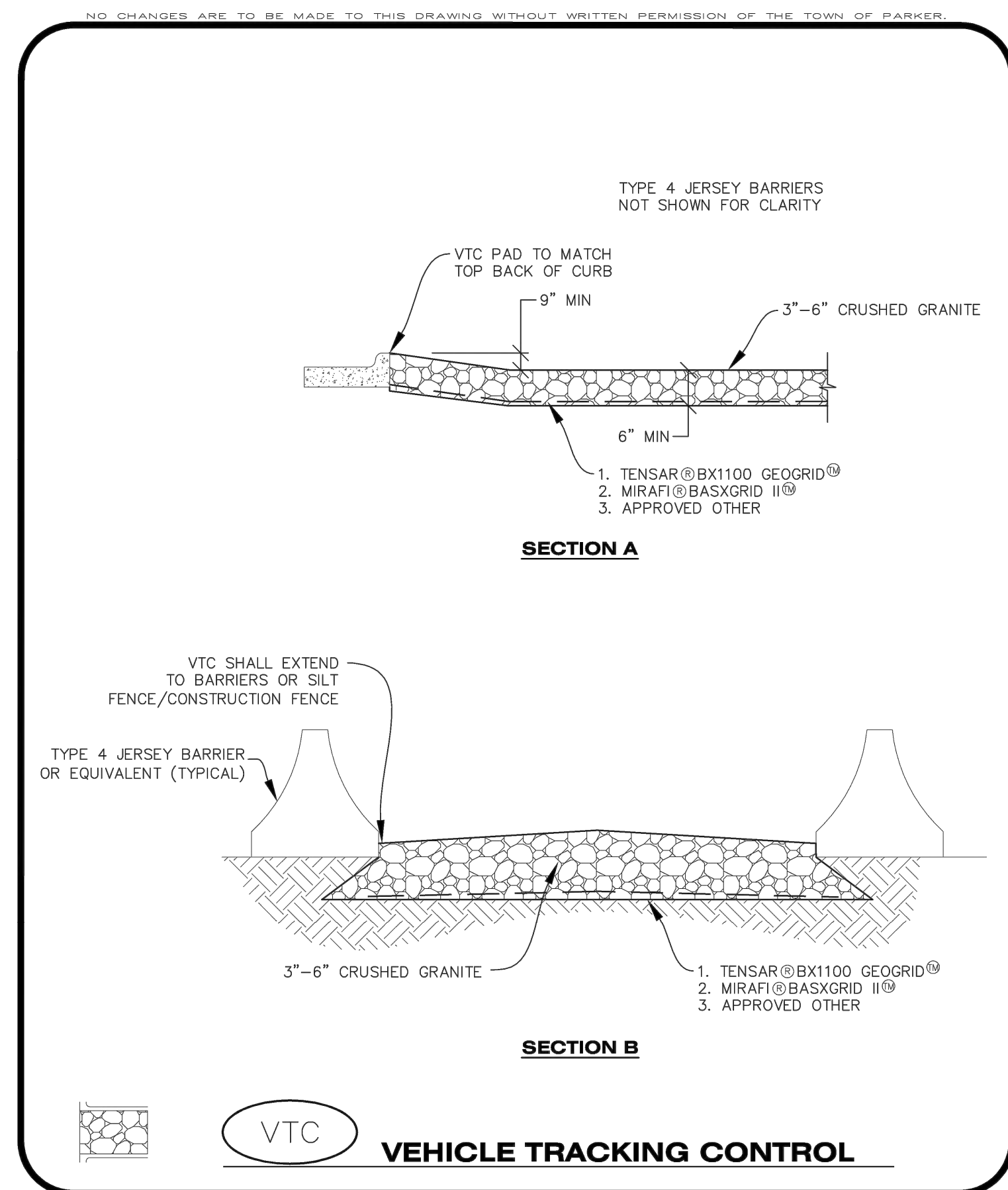

**VTC**      **CBMP**      **VTC**  
CONSTRUCTION BEST MANAGEMENT PRACTICES      2 OF 3  
Oct. 2013

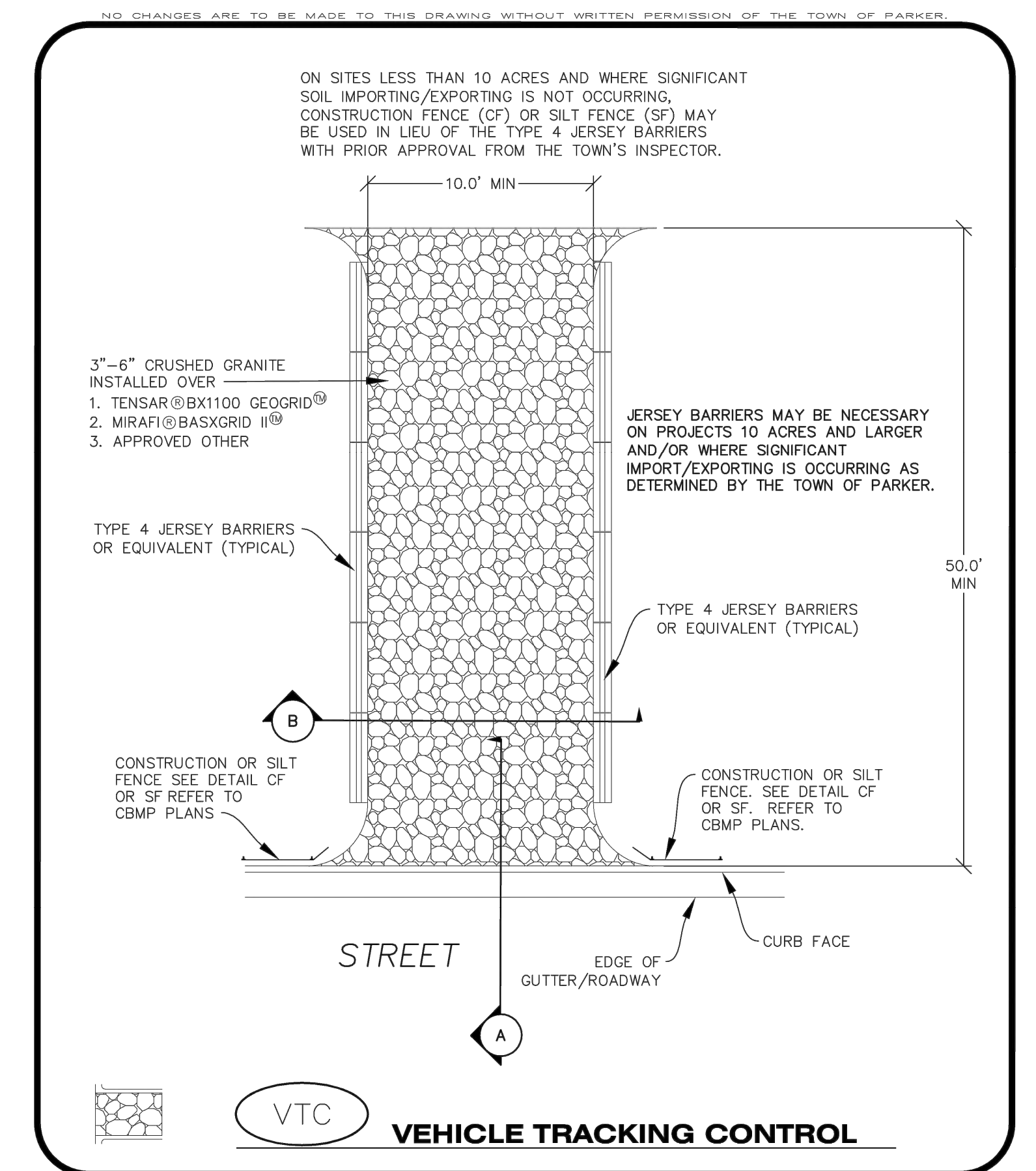

**VTC**      **CBMP**      **VTC**  
CONSTRUCTION BEST MANAGEMENT PRACTICES      1 OF 3  
Oct. 2013

FILE LOCATION: S:\CIRCLE K\MIAMI & JORDAN\100 DIVISION\4 PLAN SETS\CONSTRUCTION PLANS\CBMP\1.DWG

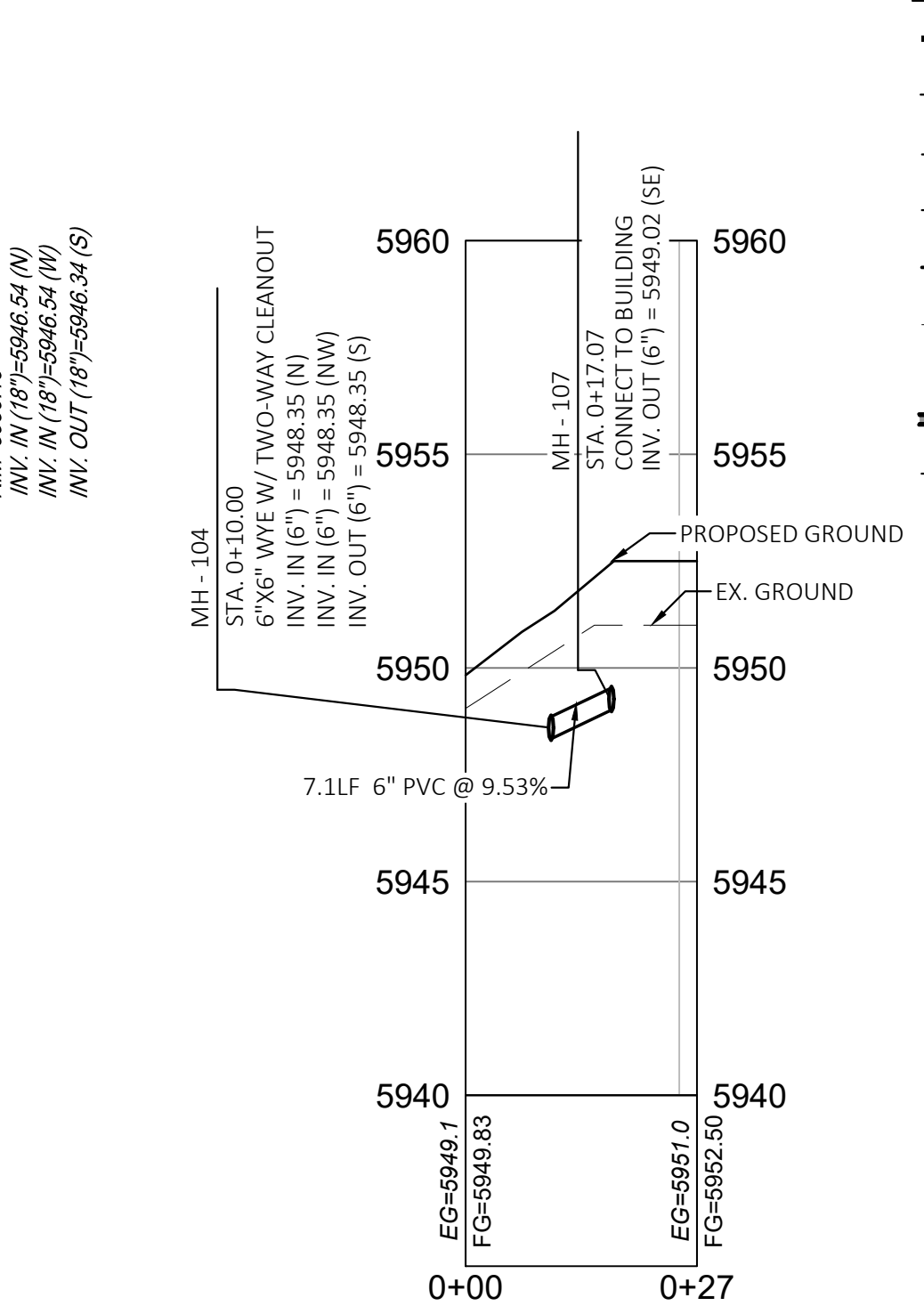
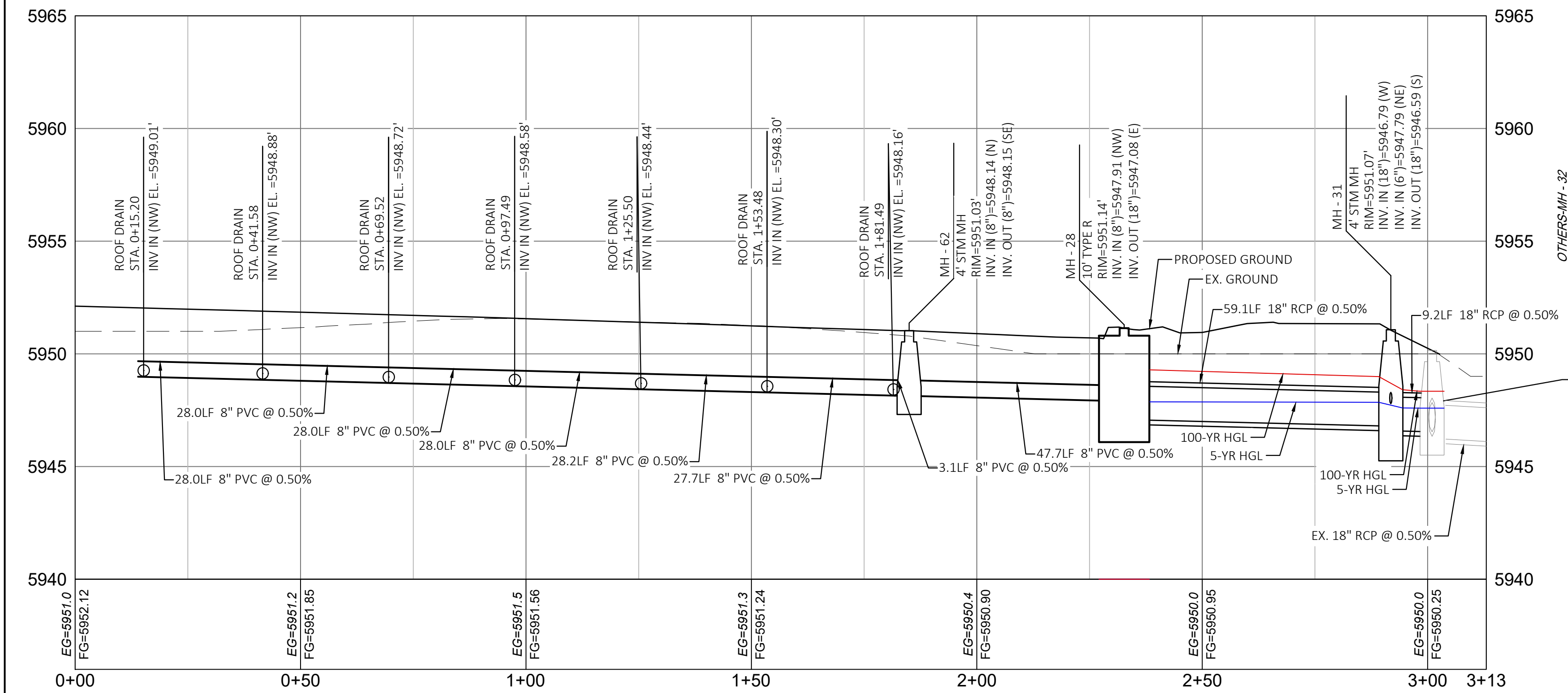
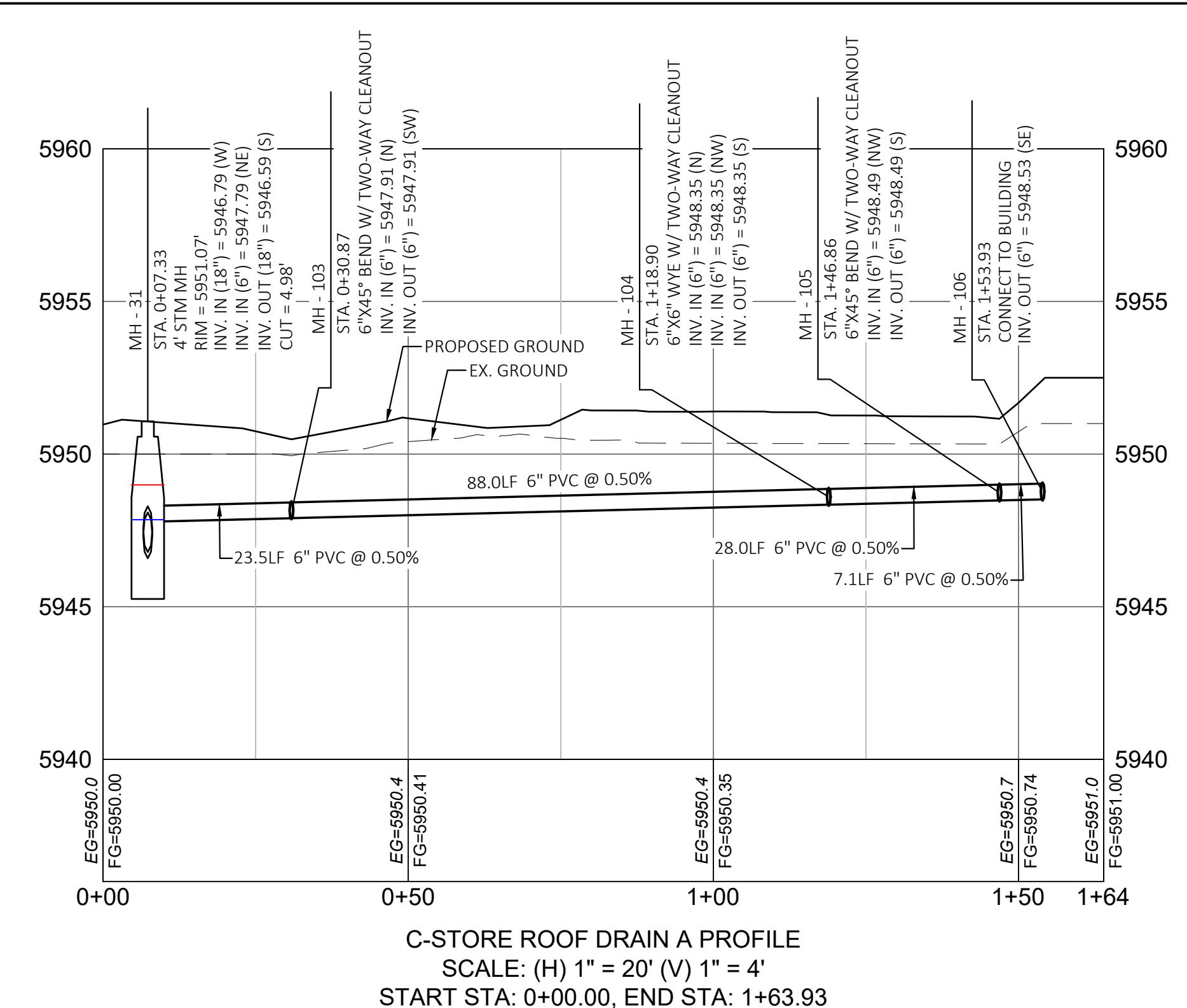
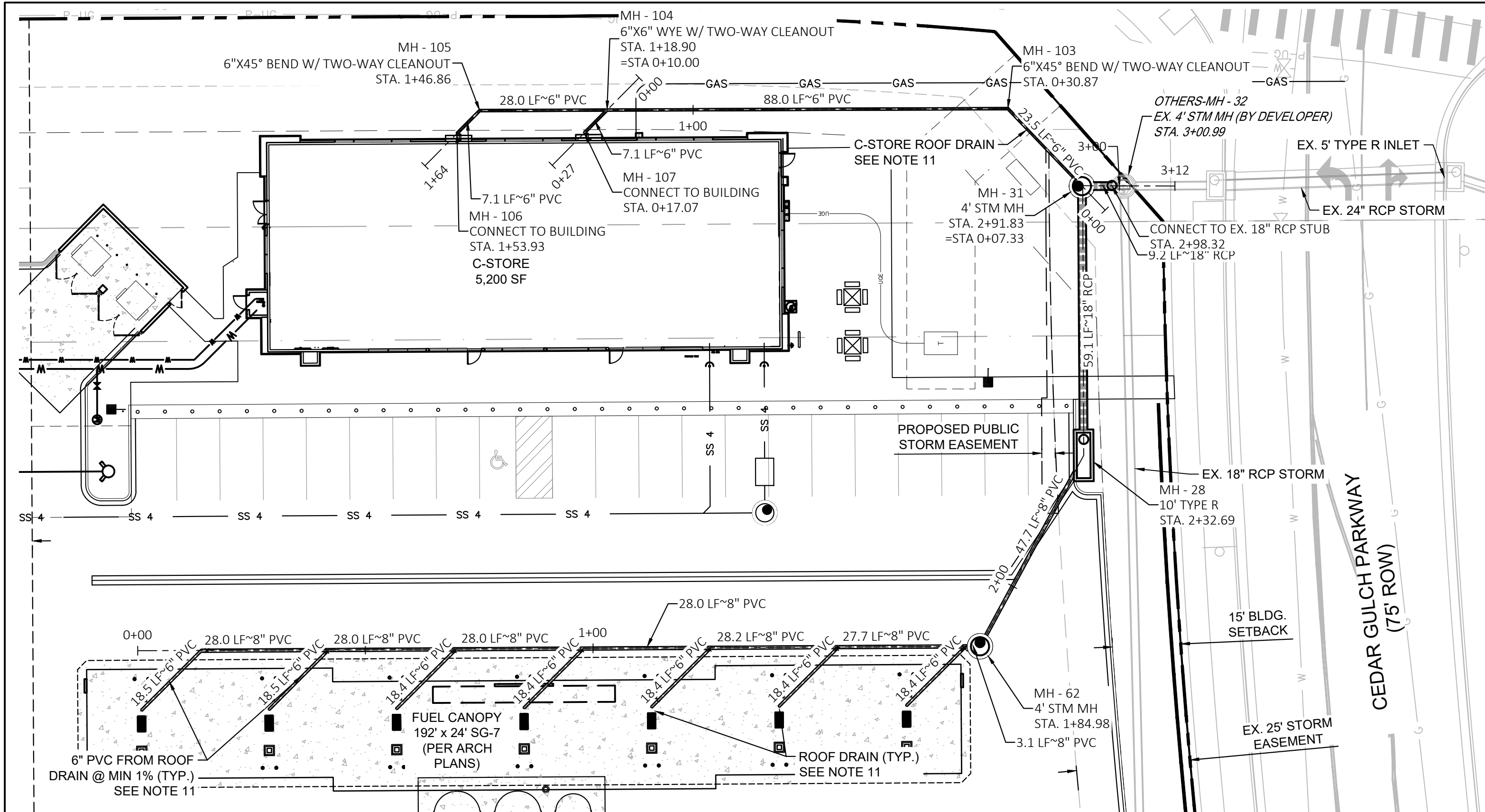

**UTILITY LEGEND**

	PROPERTY LINE
	SETBACK LINE
	EASEMENT BOUNDARY LINE
	SANITARY SEWER SERVICE
	WATER SERVICE
	UNDERGROUND ELECTRIC SERVICE
	STORM SEWER
	GAS SERVICE
	ELECTRIC TRANSFORMER

ABBREVIATIONS:  
 INV LF INVERT ELEVATION LINEAR FOOT

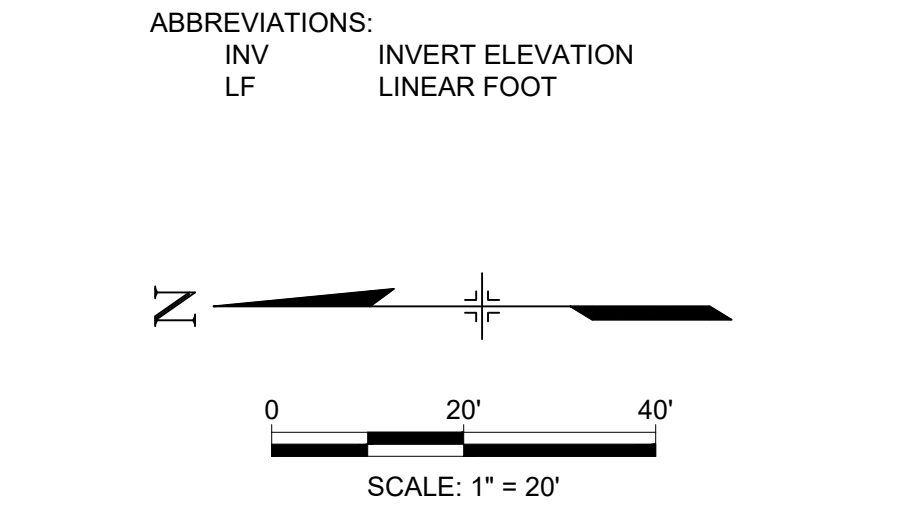

**NOTE: CONTRACTOR SHALL PROTECT ALL EXISTING SURVEY MONUMENTATION. CONTRACTOR SHALL HAVE LICENSED SURVEYOR REPLACE ANY DAMAGED OR DISTURBED MONUMENTATION AT THEIR COST.**

**NOTE: THE LOCATIONS OF EXISTING ABOVE GROUND AND UNDERGROUND UTILITIES ARE SHOWN IN AN APPROXIMATE WAY ONLY. THE CONTRACTOR SHALL DETERMINE THE EXACT LOCATION OF ALL EXISTING UTILITIES BEFORE COMMENCING WORK. THE CONTRACTOR SHALL BE FULLY RESPONSIBLE FOR ANY AND ALL DAMAGES WHICH MIGHT BE CAUSED BY THEIR FAILURE TO EXACTLY LOCATE AND PRESERVE ANY AND ALL ABOVE GROUND AND UNDERGROUND UTILITIES.**

The Town of Parker review constitutes general compliance with the Town's Standards and approved variances, subject to these plans being stamped, signed, and dated by the professional engineer of record. Review by the Town does not constitute approval of the plan design or accuracy and correctness of engineering calculations. Errors in the design or calculations remain the responsibility of the registered professional engineer whose stamp and signature are affixed to this document.

This review does not constitute approval of any private on-site improvements which may be shown. Construction cannot commence until all required drainage/traffic report(s), final development plan(s), special review(s), grading permit, and/or other permits are complete, approved and on file with the Town of Parker.

Town of Parker, Director of Engineering \_\_\_\_\_ Date \_\_\_\_\_

- NOTES:**
- CONTRACTOR TO VERIFY LOCATION & ELEVATION OF EXISTING UTILITIES.
  - ALL STORM DRAINAGE CONSTRUCTION IS SUBJECT TO THE GENERAL NOTES ON THE COVER SHEET OF THESE PLANS, AS WELL AS THE STORM DRAINAGE CONSTRUCTION NOTES LISTED HERE.
  - ALL STORM DRAINAGE PIPE SHALL HAVE A MINIMUM COVER OF 24". UNLESS OTHERWISE NOTED. UNDER NO CIRCUMSTANCES WILL ANY PIPE HAVE LESS THAN 18" COVER FROM THE FINISH SURFACE TO THE OUTSIDE WALL OF THE PIPE.
  - ALL STORM DRAINAGE PIPE SHALL BE BEDDED IN ACCORDANCE WITH STANDARD DETAILS INCLUDED. STORM SEWER PIPE SHALL BE BEDDING CLASS "B" UNLESS THE GEOTECHNICAL ENGINEER OR CITY ENGINEER DEEM NECESSARY A CHANGE IN BEDDING CLASS DUE TO SOIL CONDITION.
  - ALL STORM DRAINAGE TRENCHES SHALL BE SLOPED OF BRACED AND SHEETED AS NECESSARY, FOR THE SAFETY OF THE WORKERS AND THE PROTECTION OF OTHER UTILITIES, AND IN COMPLIANCE WITH ALL APPLICABLE STATE AND FEDERAL REQUIREMENTS. ALL EXCAVATION OPERATION SAFETY IS THE RESPONSIBILITY OF THE CONTRACTOR.
  - ALL MANHOLE RIM ELEVATIONS GIVEN ON THESE PLANS ARE TO BE CONSIDERED APPROXIMATE. THE CONTRACTOR SHALL SET THE FINAL RIM ELEVATION BASED ON THE COMPLETED FINISH SURFACE.
  - ALL STORM DRAINAGE PIPES SHALL HAVE A MINIMUM HORIZONTAL SEPARATION OF 10' FROM ALL WATER LINES.
  - LENGTHS OF STORM SEWER PIPES ARE THE HORIZONTAL DISTANCES FROM CENTER OF STRUCTURE TO CENTER OF STRUCTURE. THEREFORE, LENGTHS SHOWN ARE APPROXIMATE AND COULD VARY DUE TO VERTICAL ALIGNMENT AND STRUCTURE WIDTHS.
  - CONTRACTOR SHALL REFER TO ARCHITECTURAL PLANS FOR EXACT LOCATION OF ROOF AND CANOPY DOWNSPOUTS.
  - ASPHALT/ROAD BASE, ETC. (FOR PAVEMENT CONSTRUCTION) TO BE INSTALLED ABOVE STORM PIPE BACKFILL SHALL BE ACCORDING TO GEOTECHNICAL REPORT PREPARED FOR THIS PROJECT.
  - THE FUEL CANOPY AND C-STORE ROOF DRAIN SYSTEMS ARE PRIVATE.



**CONSULTANTS:**

**Matrix**  
 2435 RESEARCH PARKWAY, SUITE 300  
 COLORADO SPRINGS, CO 80920  
 PHONE: (719) 575-0100  
 FAX: (719) 575-0208

**LAND DEVELOPMENT CONSULTANTS, LLC**  
 950 S. CHERRY STREET, SUITE 512  
 DENVER, CO 80246

OWNER/DEVELOPER:

**CIRCLE K**

ROCKY MOUNTAINS DIVISION  
 5500 S. QUEBEC STREET, SUITE 100  
 GREENWOOD VILLAGE, CO 80111

FOR AND ON BEHALF OF MATRIX DESIGN GROUP, INC. CONTRACTOR IS RESPONSIBLE FOR OBTAINING THE MOST RECENT PROJECT CONSTRUCTION DOCUMENTS. MATRIX DESIGN GROUP IS NOT RESPONSIBLE FOR CHANGES, ALTERATIONS, OR USE OF CONSTRUCTION DOCUMENTS PRIOR TO JURISDICTIONAL APPROVAL.

VICINITY MAP: SCALE: NTS

PROJECT:  
**CIRCLE K**  
**CONSTRUCTION DOCUMENTS**  
 16846 E AUBURN HILLS DRIVE  
 PARKER, CO 80134

REVISION HISTORY:

NO.	DATE	DESCRIPTION	BY

DRAWING INFORMATION:

PROJECT NO: 21.1207.030  
 DRAWN BY: RAD  
 CHECKED BY: NMS  
 DESIGNED BY: NMS

**STORM DRAINAGE PLAN & PROFILE**

**C5.0**

SHEET 24 OF 26

DATE: NOVEMBER 2022

FILE LOCATION: \\CIRCLE K\MAIN & JORDAN\100 DIVISION\104 PLAN SETS\CONSTRUCTION PLANS\SD01.DWG

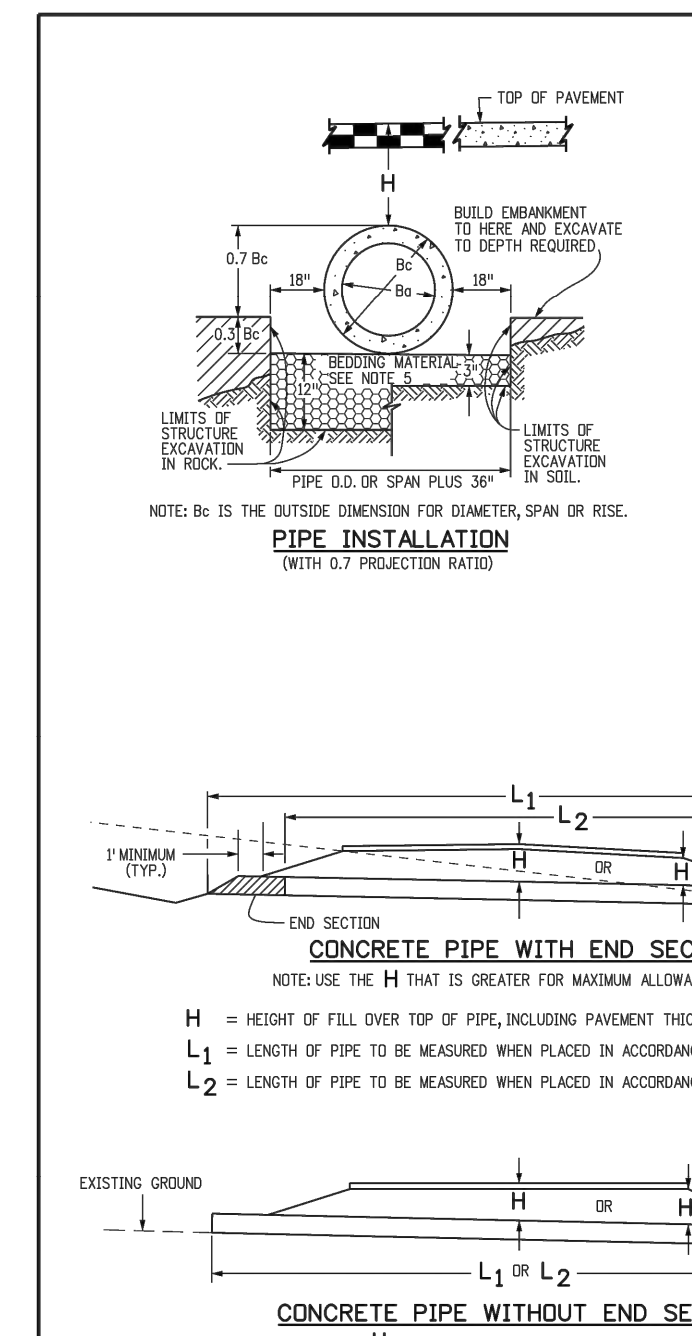

PIPE SIZE - Ø <sub>OUT</sub>	CIRCULAR (C/R)		VERTICAL ELLIPTICAL (V/E)		HORIZONTAL ELLIPTICAL (H/E)	
	WALL THICKNESS	Ø <sub>3</sub> B <sub>C</sub> (OUTSIDE DIA)	SPAN	RISE	SPAN	RISE
12	2	0.40			23	14
15	2 1/2	0.49				
18	2 1/2	0.58				
21	2 3/4	0.66				
24	3	0.75				
27	3 1/4	0.84				
30	3 1/2	0.92				
33	3 3/4	1.01				
36	4	1.10	29	45	4 1/2	29
42	4 1/2	1.28	34	55	5	34
48	5	1.45	38	60	5 1/2	38
54	5 1/2	1.62	43	68	6	43
60	6	1.80	48	76	6 1/2	48
66	6 1/2	1.97	53	83	7	53
72	7	2.15	58	91	7 1/2	58
78	7 1/2	2.32	63	99	8	63
84	8	2.50	68	106	8 1/2	68
90	8 1/2	2.68	72	113	9	72
96	9	2.85	77	121	9 1/2	77
102	9 1/2	3.02	82	129	10	82
108	10	3.20	87	138	10 1/2	87

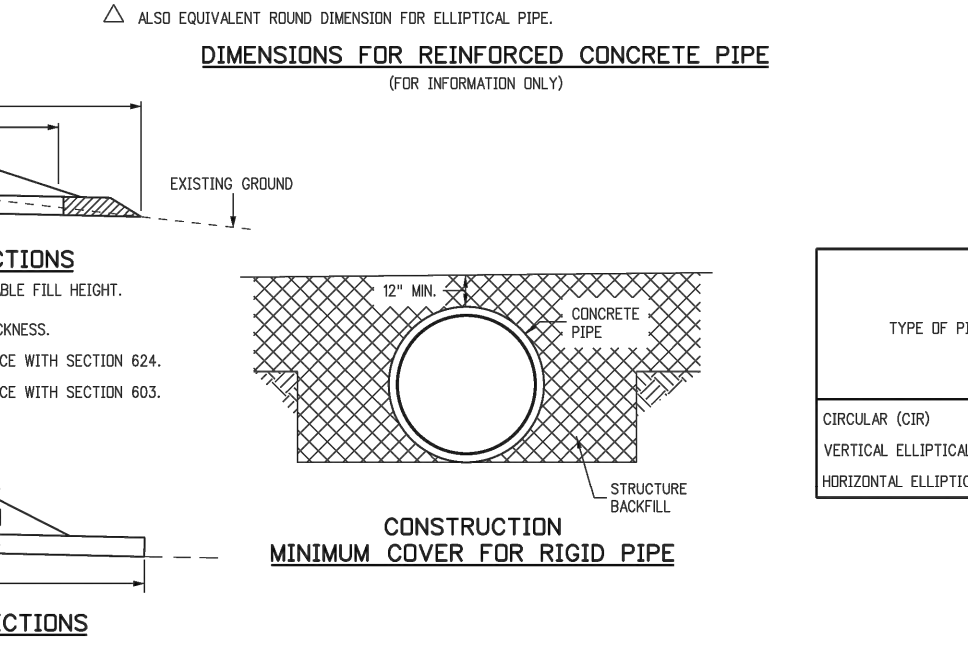

**GENERAL NOTES**

**REINFORCED CONCRETE PIPE**

- FILL HEIGHTS GREATER THAN MAXIMUM ALLOWABLE IN THE HEIGHTS OF FILL TABLE ON THIS SHEET REQUIRE SPECIAL DESIGN OF STRUCTURE.
- PIPE DESIGN IS BASED ON SAFETY FACTOR OF 1.33 ON ULTIMATE STRENGTH.
- THE HEIGHTS OF FILL OVER TOP OF PIPE ARE BASED ON UNIT WEIGHT OF SOIL AT 125 LBS PER CUBIC FT.
- PIPE CLASS IS DETERMINED FROM 0.10 IN CRACK CH-LONG.
- REDDING IS CLASS B (UNDEF'D) FROM CONCRETE PIPE DESIGN MANUAL-AMERICAN CONCRETE PIPE ASSOCIATION WITH SETTLEMENT RATIO = 0.01 (TYPICAL) REDD. REDDING MATERIAL FOR RIGID PIPE IN SOIL SHALL BE 3 IN. LOOSE THICKNESS STRUCTURE BACKFILL CLASS 2 REDDING MATERIAL FOR RIGID PIPE IN ROCK SHALL BE 12 IN. LOOSE THICKNESS STRUCTURE BACKFILL CLASS 1.
- CHANGES IN DESIGN FACTORS REQUIRE COMPENSATING CHANGES IN PIPE DESIGN.
- MINIMUM WALL THICKNESS DIMENSIONS ARE BASED ON ASHOTO W 170 (WALL B) FOR CIRCULAR PIPE AND ASHOTO W 207 FOR ELLIPTICAL PIPE.
- SPACING FOR MULTIPLE PIPE INSTALLATIONS SHALL CONFORM TO THE DETAILS SHOWN ON STANDARD PLAN NO. 1.
- WHEN A PIPE IS TO BE EXTENDED, THE SAME PIPE MATERIAL AND SIZE AS IN THE ORIGINAL PIPE INSTALLATION SHALL BE USED.

**NONREINFORCED CONCRETE PIPE**

- AT THE OPTION OF THE CONTRACTOR, NONREINFORCED CONCRETE PIPE CONFORMING TO ASHOTO W 80 MAY BE USED IN LIEU OF REINFORCED CONCRETE PIPE FOR ALL SIZES OR INKES IN CONCRETE AND SHALL BE NONREINFORCED CONCRETE PIPE. SHALL MEET THE SAME D-LOAD TO PRODUCE THE ULTIMATE LOAD UNDER THE THREE-EDGE BEARING METHOD AS SPECIFIED FOR REINFORCED CONCRETE PIPE IN CONFORMANCE WITH ASHOTO W 170. THE CONTRACTOR SHALL PROVIDE WRITTEN CERTIFICATION OF CONFIRMING THE WALL THICKNESS OF THE NONREINFORCED PIPE MAY BE INCREASED AS REQUIRED TO MEET D-LOAD REQUIREMENT.
- ALL REQUIREMENTS FOR REINFORCED CONCRETE PIPE, EXCEPT THOSE REFERRING TO REINFORCEMENT, SHALL APPLY TO NONREINFORCED CONCRETE PIPE.

**ALLOWABLE RANGE OF HEIGHTS FOR FILL OVER REINFORCED CONCRETE PIPE (ALL SIZES)**

TYPE OF PIPE	HEIGHT OF FILL OVER TOP OF PIPE, H (FEET)					
	CLASS OR I	CLASS OR II	CLASS OR III	CLASS OR IV	CLASS OR V	CLASS OR VI
CIRCULAR (C/R)	1:10	1:10	25:37	37:45	45:53	45:53
VERTICAL ELLIPTICAL (V/E)	1:10	1:10	25:37	37:45	45:53	45:53
HORIZONTAL ELLIPTICAL (H/E)	1:10	1:10	25:37	37:45	45:53	45:53

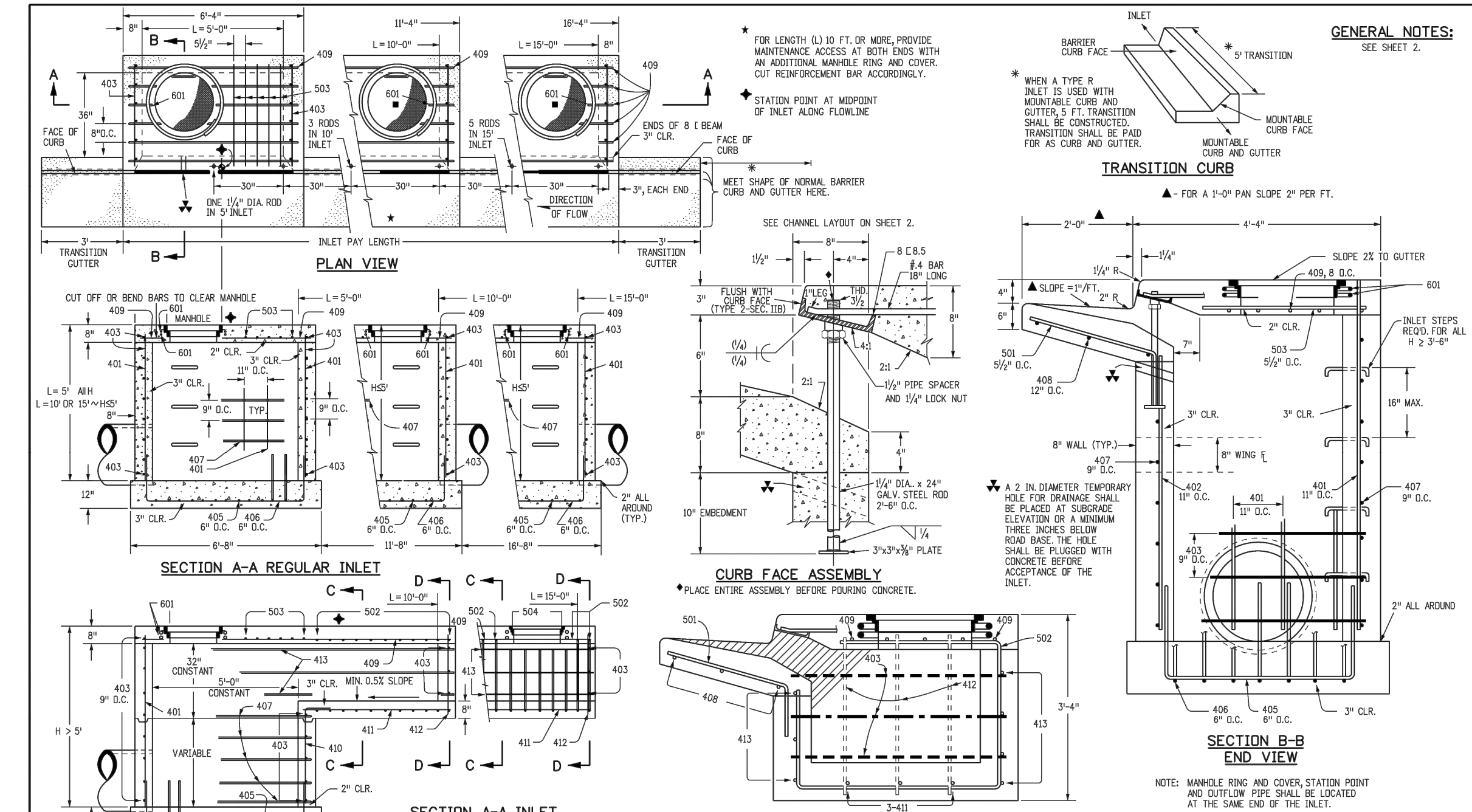

**Computer File Information**

Creation Date: 07/31/19  
Designer Initials: JBK  
Last Modification Date: 07/31/19  
Developer Initials: LTA  
CAD Ver.: MicroStation V8 Scale: Not to Scale Units: English

**Sheet Revisions**

Date:	Comments:

**Colorado Department of Transportation**  
2829 West Howard Place  
Denver, CO 80204  
Phone: 303-757-9021 FAX: 303-757-9868

**REINFORCED CONCRETE PIPE**  
Issued by the Project Development Branch July 31, 2019

**STANDARD PLAN NO. M-603-2**  
Standard Sheet No. 1 of 1  
Project Sheet Number:

**Computer File Information**

Creation Date: 07/31/19  
Designer Initials: JBK  
Last Modification Date: 07/31/19  
Developer Initials: LTA  
CAD Ver.: MicroStation V8 Scale: Not to Scale Units: English

**Sheet Revisions**

Date:	Comments:

**Colorado Department of Transportation**  
2829 West Howard Place  
Denver, CO 80204  
Phone: 303-757-9021 FAX: 303-757-9868

**CURB INLET TYPE R**  
Issued by the Project Development Branch July 31, 2019

**STANDARD PLAN NO. M-604-12**  
Standard Sheet No. 1 of 2  
Project Sheet Number:

MARK	BAR #	Ø	I.C. SIZE	TYPE	ALL INLETS			
					L = 5 FT.	L = 10 FT.	L = 15 FT.	L = 10 FT.
402	4	11"	II	15	21	26	26	26
403	4	9"	II	8	13	18	18	18
404	4	8"	II	8	13	18	18	18
405	4	6"	VI	11	16	21	21	21
406	4	6"	VIII	7	11	15	15	15
407	4	9"	II	15	21	26	26	26
408	4	12"	II	3	5	7	7	7
409	4	8"	II	6	9	12	12	12
410	4	11"	VIII	11	16	21	21	21
411	4	11"	II	15	21	26	26	26
412	4	11"	II	15	21	26	26	26
413	4	9"	II	15	21	26	26	26
501	5	3 1/2"	IV	11	16	21	21	21
502	5	3 1/2"	III	11	16	21	21	21
503	5	3 1/2"	II	5	8	11	11	11
504	5	3 1/2"	Ix	5	8	11	11	11
601	6	2 1/2"	V	2	3	4	4	4

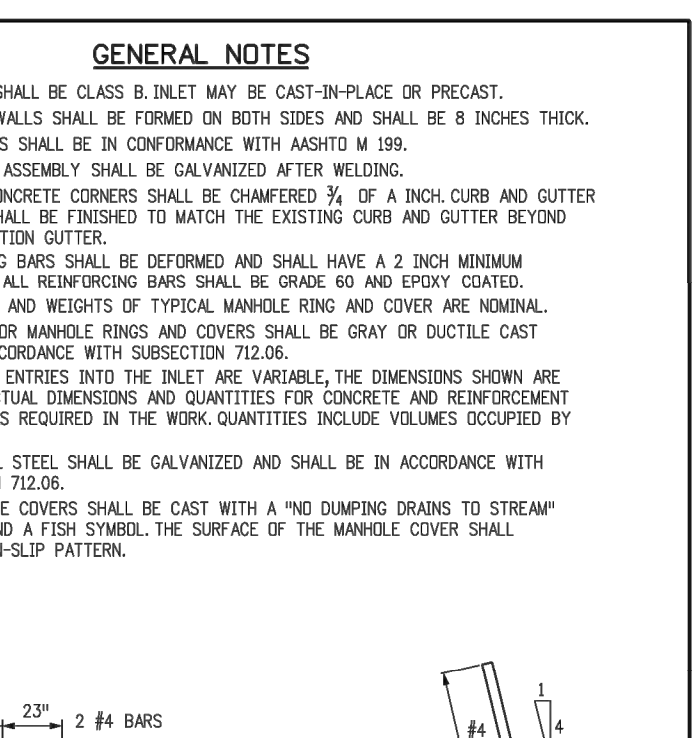
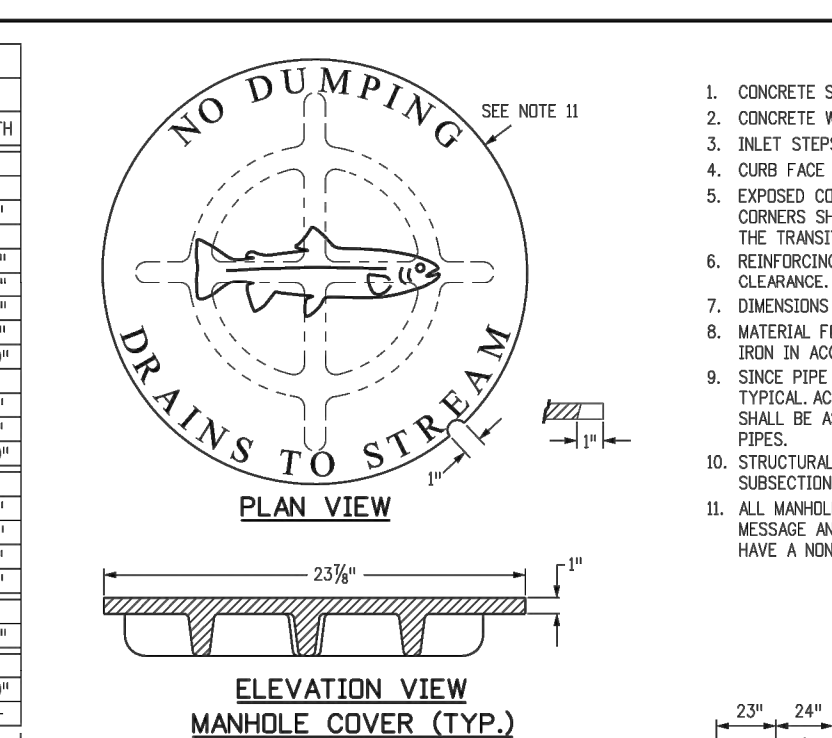

**TABLE ONE ~ BAR LIST FOR CURB INLETS, TYPE "R"**

H <sub>41</sub>	LENGTH	REGULAR		DROP BOX		L = 5 FT.		L = 10 FT.		L = 15 FT.	
		NO. REQ.	Ø <sub>3</sub> DIA.	NO. REQ.	Ø <sub>3</sub> DIA.	CONC. Ø <sub>3</sub> DIA.	STEEL Ø <sub>3</sub> DIA.	CONC. Ø <sub>3</sub> DIA.	STEEL Ø <sub>3</sub> DIA.	CONC. Ø <sub>3</sub> DIA.	STEEL Ø <sub>3</sub> DIA.
3'-0"	2'-8"	10	7	3.2	285	5.3	497	7.4	706		
3'-6"	3'-2"	10	7	3.4	305	5.7	528	7.9	747		
4'-0"	3'-8"	12	9	3.7	338	6.0	559	8.4	786		
4'-6"	4'-2"	12	9	3.9	354	6.4	571	8.8	803		
5'-0"	4'-8"	14	11	4.1	354	6.7	602	9.3	844		
5'-6"	5'-2"	16	13	4.4	375	7.0	633	9.7	875		
6'-0"	5'-8"	16	13	4.6	382	7.2	646	10.0	888		
6'-6"	6'-2"	18	15	4.8	402	7.4	657	10.4	919		
7'-0"	6'-8"	18	15	5.0	423	7.6	669	10.8	950		
7'-6"	7'-2"	20	17	5.2	430	7.8	681	11.2	981		
8'-0"	7'-8"	22	19	5.4	451	8.0	692	11.6	1012		
8'-6"	8'-2"	24	21	5.6	471	8.2	703	12.0	1043		
9'-0"	8'-8"	24	21	5.8	479	8.4	715	12.4	1074		
9'-6"	9'-2"	26	23	6.0	499	8.6	726	12.8	1105		
10'-0"	9'-8"	28	25	6.2	520	8.8	737	13.2	1136		
10'-6"	10'-2"	28	25	6.4	527	9.0	749	13.6	1167		
11'-0"	10'-8"	30	27	6.6	547	9.2	760	14.0	1198		

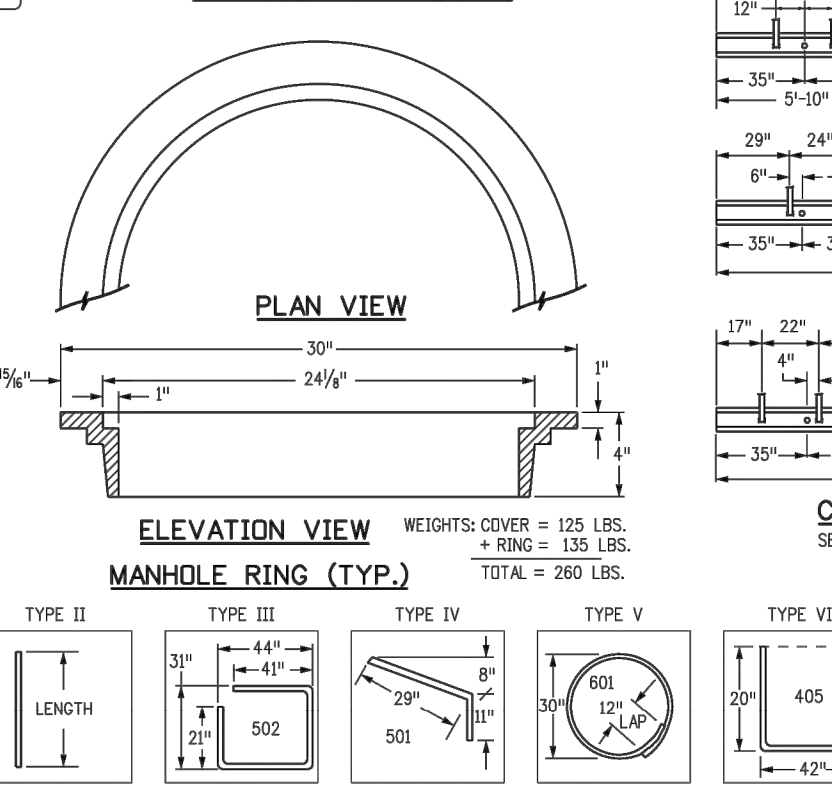

**TABLE TWO ~ BARS AND QUANTITIES VARIABLE WITH "H"**

H <sub>41</sub>	LENGTH	REGULAR		DROP BOX		L = 5 FT.		L = 10 FT.		L = 15 FT.	
		NO. REQ.	Ø <sub>3</sub> DIA.	NO. REQ.	Ø <sub>3</sub> DIA.	CONC. Ø <sub>3</sub> DIA.	STEEL Ø <sub>3</sub> DIA.	CONC. Ø <sub>3</sub> DIA.	STEEL Ø <sub>3</sub> DIA.	CONC. Ø <sub>3</sub> DIA.	STEEL Ø <sub>3</sub> DIA.
3'-0"	2'-8"	10	7	3.2	285	5.3	497	7.4	706		
3'-6"	3'-2"	10	7	3.4	305	5.7	528	7.9	747		
4'-0"	3'-8"	12	9	3.7	338	6.0	559	8.4	786		
4'-6"	4'-2"	12	9	3.9	354	6.4	571	8.8	803		
5'-0"	4'-8"	14	11	4.1	354	6.7	602	9.3	844		
5'-6"	5'-2"	16	13	4.4	375	7.0	633	9.7	875		
6'-0"	5'-8"	16	13	4.6	382	7.2	646	10.0	888		
6'-6"	6'-2"	18	15	4.8	402	7.4	657	10.4	919		
7'-0"	6'-8"	18	15	5.0	423	7.6	669	10.8	950		
7'-6"	7'-2"	20	17	5.2	430	7.8	681	11.2	981		
8'-0"	7'-8"	22	19	5.4	451	8.0	692	11.6	1012		
8'-6"	8'-2"	24	21	5.6	471	8.2	703	12.0	1043		
9'-0"	8'-8"	24	21	5.8	479	8.4	715	12.4	1074		
9'-6"	9'-2"	26	23	6.0	499	8.6	726	12.8	1105		
10'-0"	9'-8"	28	25	6.2	520	8.8	737	13.2	1136		
10'-6"	10'-2"	28	25	6.4	527	9.0	749	13.6	1167		
11'-0"	10'-8"	30	27	6.6	547	9.2	760	14.0	1198		

**Computer File Information**

Creation Date: 07/31/19  
Designer Initials: JBK  
Last Modification Date: 07/31/19  
Developer Initials: LTA  
CAD Ver.: MicroStation V8 Scale: Not to Scale Units: English

**Sheet Revisions**

Date:	Comments:

**Colorado Department of Transportation**  
2829 West Howard Place  
Denver, CO 80204  
Phone: 303-757-9021 FAX: 303-757-9868

**CURB INLET TYPE R**  
Issued by the Project Development Branch July 31, 2019

**STANDARD PLAN NO. M-604-12**  
Standard Sheet No. 2 of 2  
Project Sheet Number:

**Computer File Information**

Creation Date: 07/31/19  
Designer Initials: JBK  
Last Modification Date: 07/31/19  
Developer Initials: LTA  
CAD Ver.: MicroStation V8 Scale: Not to Scale Units: English

**Sheet Revisions**

Date:	Comments:



Know what's below.  
Call before you dig.

CONSULTANTS:



2435 RESEARCH PARKWAY, SUITE 300  
COLORADO SPRINGS, CO 80920  
PHONE: (719) 575-0100  
FAX: (719) 575-0208



LAND DEVELOPMENT  
CONSULTANTS, LLC

950 S. CHERRY STREET, SUITE 512  
DENVER, CO 80246

OWNER/DEVELOPER:



ROCKY MOUNTAINS DIVISION  
5500 S. QUEBEC STREET, SUITE 100  
GREENWOOD VILLAGE, CO 80111

SEAL

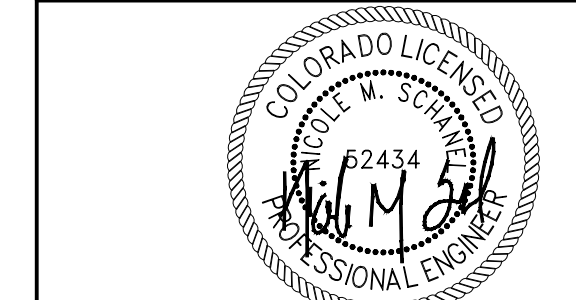

FOR AND ON BEHALF OF MATRIX DESIGN GROUP, INC.  
CONTRACTOR IS RESPONSIBLE FOR OBTAINING THE  
MOST RECENT PROJECT CONSTRUCTION DOCUMENTS.  
MATRIX DESIGN GROUP IS NOT RESPONSIBLE FOR  
CHANGES, ALTERATIONS, OR USE OF CONSTRUCTION  
DOCUMENTS PRIOR TO JURISDICTIONAL APPROVAL.

VICINITY MAP: SCALE: NTS

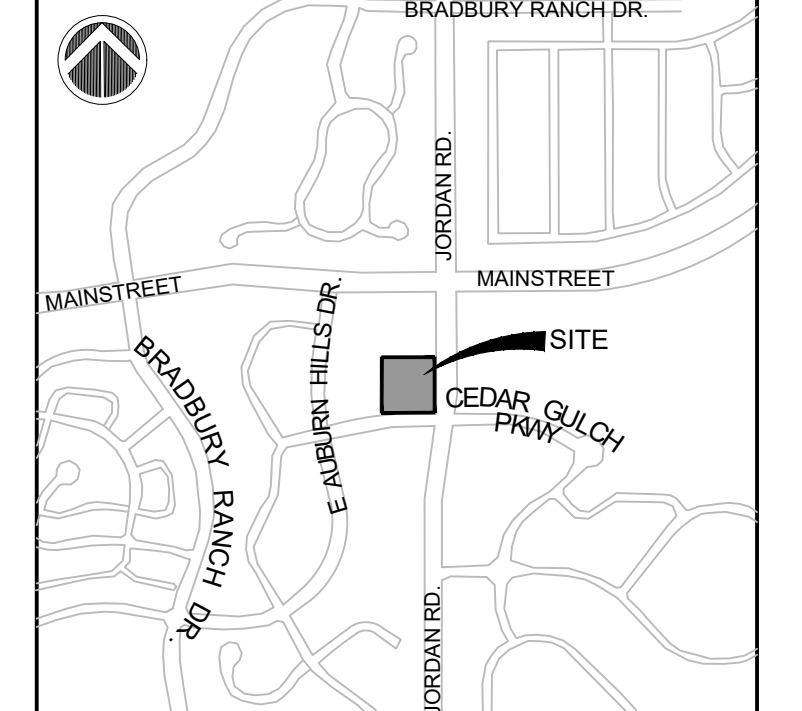

PROJECT:

CIRCLE K

CONSTRUCTION DOCUMENTS

16846 E AUBURN HILLS DRIVE  
PARKER, CO 80134

REVISION HISTORY:

NO.	DATE	DESCRIPTION	BY

DRAWING INFORMATION:

PROJECT NO: 21.1207.030

DRAWN BY: RAD

CHECKED BY: NMS

DESIGNED BY: NMS

SHEET TITLE:

STORM  
DRAINAGE  
DETAILS

C5.2

SHEET 26 OF 26

DATE: NOVEMBER 2022

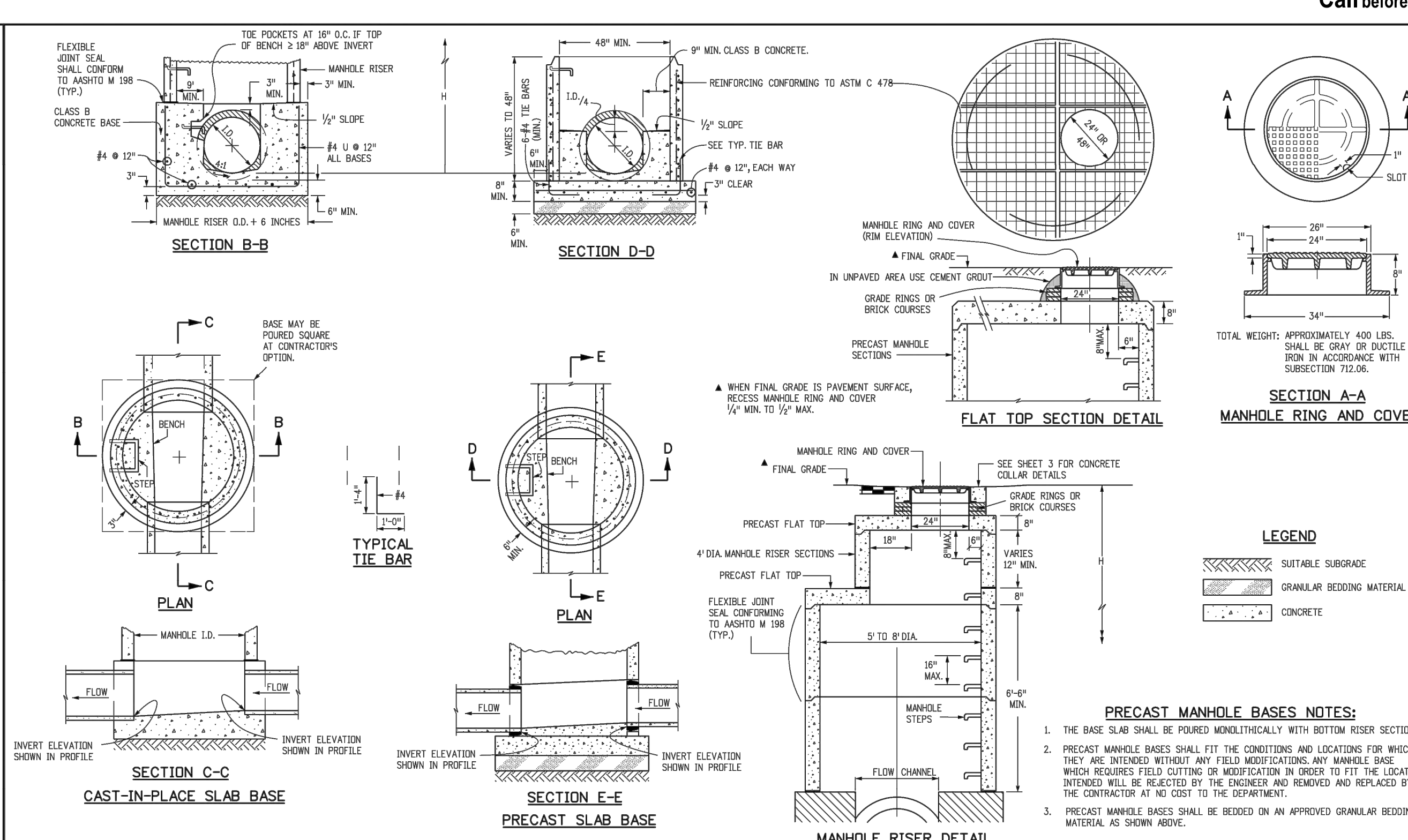
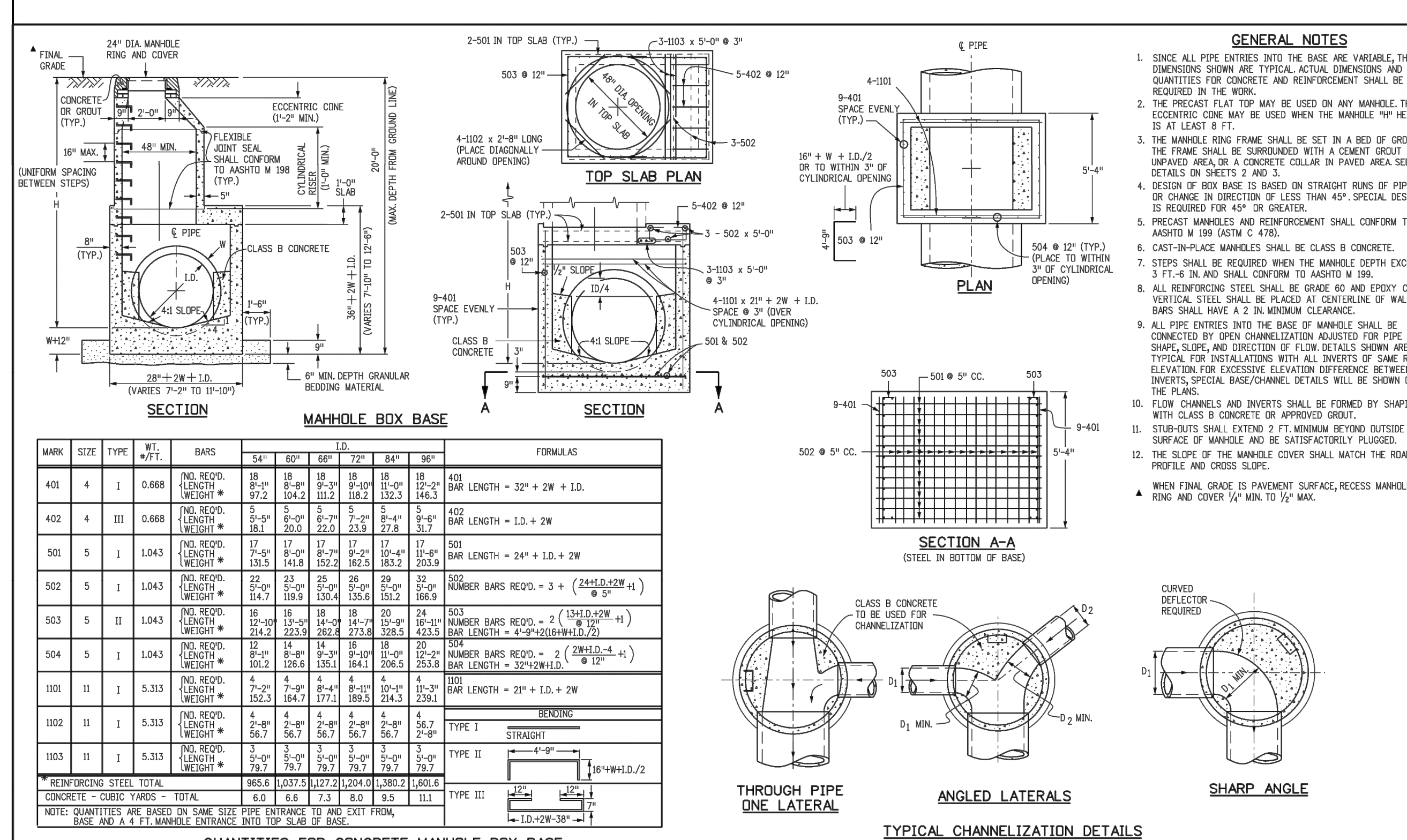

Computer File Information

Creation Date: 07/31/19  
Designer: JBK  
Last Modification Date: 07/31/19  
Detailer: LTA  
CAD Ver.: MicroStation V8 Scale: Not to Scale Units: English

Colorado Department of Transportation  
2829 West Howard Place  
Denver, CO 80204  
Phone: 303-757-9868  
Project Development Branch JBK

**MANHOLES**

STANDARD PLAN NO. M-604-20  
Standard Sheet No. 1 of 3

Computer File Information  
Creation Date: 07/31/19  
Designer: JBK  
Last Modification Date: 07/31/19  
Detailer: LTA  
CAD Ver.: MicroStation V8 Scale: Not to Scale Units: English

Colorado Department of Transportation  
2829 West Howard Place  
Denver, CO 80204  
Phone: 303-757-9868  
Project Development Branch JBK

**MANHOLES**

STANDARD PLAN NO. M-604-20  
Standard Sheet No. 2 of 3

Colorado Department of Transportation  
2829 West Howard Place  
Denver, CO 80204  
Phone: 303-757-9868  
Project Development Branch JBK

**MANHOLES**

STANDARD PLAN NO. M-604-20  
Standard Sheet No. 2 of 3

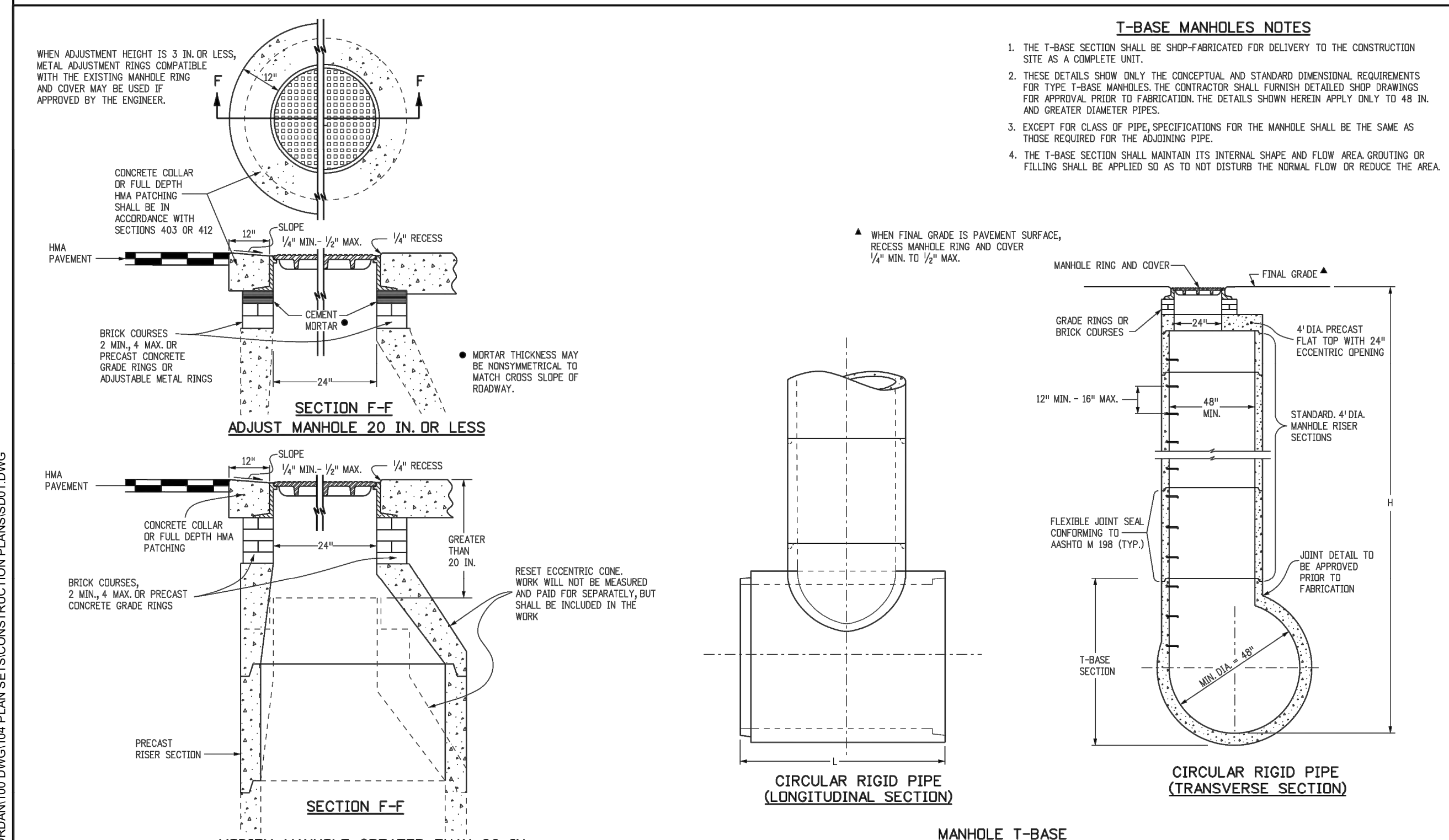

Computer File Information

Creation Date: 07/31/19  
Designer: JBK  
Last Modification Date: 07/31/19  
Detailer: LTA  
CAD Ver.: MicroStation V8 Scale: Not to Scale Units: English

Colorado Department of Transportation  
2829 West Howard Place  
Denver, CO 80204  
Phone: 303-757-9868  
Project Development Branch JBK

**MANHOLES**

STANDARD PLAN NO. M-604-20  
Standard Sheet No. 3 of 3

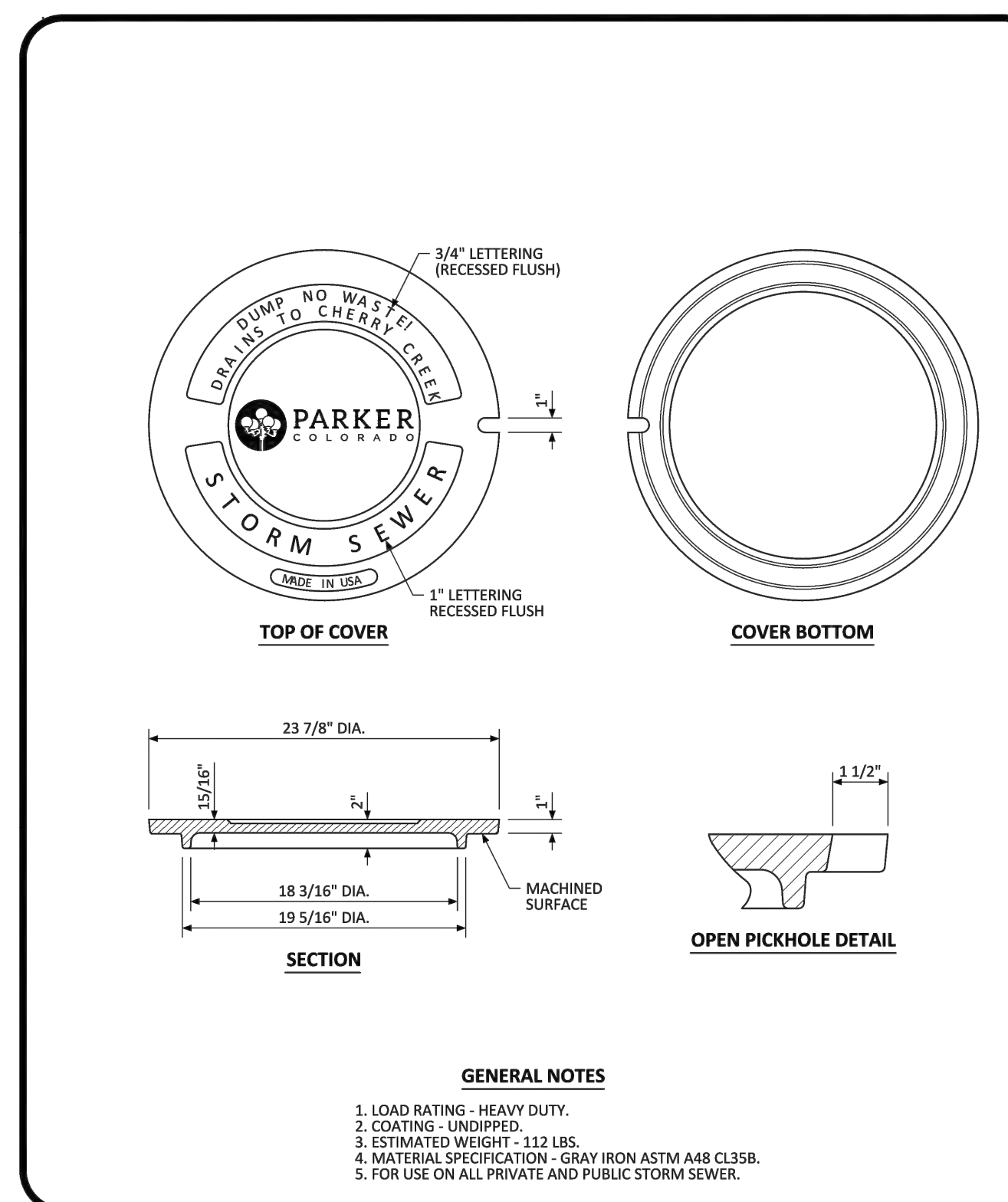

PARKER COLORADO

**MANHOLE COVER STANDARD DETAIL**

DATE NOVEMBER 2020

DETAIL 33

1 OF 1

FILE LOCATION: S:\CIRCLE K\MANHOLE DIVISION\04.PLAN SETS\CONSTRUCTION\PLANS\SD01.DWG