



Town of Parker Community Development Department
 Development Review Division
 Attention: ~~Carson Byerhof~~ *Ashley Chasez*

Application Type: **Site Plan**
 Status: **First Referral**
 Application Name: Douglas 234 F6 AMD 1 L4 - Dunkin Donuts
 Case/AP#: **SP22-041**
 Referral Received: June 13, 2022
 Comments Due: July 13, 2022

Application Location: Generally located north/east of Chambers and Hess Road
 Review date: **June 27, 2022**
 Plan reviewer: **Randall L. Capra**, rcapra@parkeronline.org
 Phone: 303.805.3163

Narrative: The applicant, Ethos Architecture, is proposing a 2,108 sq. ft. drive through donut store. The site is located northeast of Hess Road and Chambers Road.

Code Reference: 2021 International Fire Code, 2021 International Building Code, 2020 NEC

TOWN OF PARKER FIRE/LIFE SAFETY:	R REVIEWED FOR CODE COMPLIANCE; REVISIONS REQUIRED
---	---

- 1st Submittal – Reviewed June 27, 2022
- 2nd Submittal – Reviewed September 26, 2023 (*Comments in red, italicized font*)

UNRESOLVED ISSUES/COMMENTS

The items noted below with a comment number (1, 2 etc.) are items that need to be corrected to show compliance with the applicable codes. Please provide a written response to this letter indicating where the corrections are made on the plans (cloud the plans as applicable). This will speed up the second review process.

1. During the pre-application meetings, the applicant was informed that the concept planned submitted would not be allowed. The applicant has created a long dead end (approximately 260') without an approved turn-around. This project, as submitted, is denied.

The applicant, when revisiting the site plan shall be aware that no-dead ends are allowed that exceed 150 feet; the measurement would occur from center line of the access that is perpendicular to the access road on site.

Where access cannot be provided to within 150' of all points of the building (once an approved access is constructed, the building would be required to be sprinklered. If this were the case, riser room would need to be located on the access side of the building and sized to accommodate the FACP (fire alarm control panel) and the fire sprinkler riser. The domestic would be allowed to be housed in this room so long as the required clearances are provided.

This comment will serve to formalize the requirements of [21 IFC Section 503.1.1 Buildings and Facilities] where approved fire apparatus access roads shall be provided for every facility, building, portion of a building hereafter constructed or moved into or within the jurisdiction. The fire apparatus access road shall comply with the requirements of this section and shall extend to within 150 feet of all portions of the facility and all portions of the exterior walls of the first story of the building as measured by an approved route around the exterior of the building or facility. The center line of the fire apparatus as measured by an approved route from any point that a fire engine might park when responding to a call at this building).

This submittal does not provide for this requirement of the code. Per the requirements of the code, the fire code official is allowed to increase the dimension of the 150 feet provided that the applicant meets Exception 1.1 of this

section... “The building is equipped throughout with an approved automatic sprinkler suppression system installed in accordance with section 903.1.1, 903.1.2, or 903.3.1.3. The applicant will need to address this issue when resubmitting.

The riser room shall be sized to accommodate the following:

- The underground fire line is not allowed to have domestic tapped off of it
- The sprinkler riser is allowed to enter no further than 24-inches into the building (and any less than 12-inches into the building).
- A three-foot clearance shall be provided in front of the riser (with 18” of clearance on either side of the riser).
- The fire alarm control panel (FACP) is required to be located on an interior wall.
- A three-foot clearance is required in front of the FACP.
- Exterior access is required to be provided into the riser room; this access shall be approved.
- Access into the building shall be provided through the riser room or immediately adjacent to the riser room.
- While domestic water can be located in the riser room, the domestic cannot be located in any way that conflicts with the access requirements for both the FACP and the sprinkler riser.
- A sidewalk is required to the riser room and a 5 x 5 pad is required in front of the FDC.
- **The fire hydrant cannot share the same water tap as the UFL.**

Should sprinklers be required, the applicant would be required to provide a floor plan of how the riser room is to be laid out to avoid conflicts with the site plan once the building review submittal has been made. **Not satisfied; while the applicant has indicated that the building is to be sprinklered per NFPA 13, the applicant has not identified the location of the riser room or provided a floor plan to ensure that the room is sized as required nor has the applicant included the UFL on the overall utility sheet. As noted, the UFL shall have its own independent tap. Identify the length and size of the UFL on the plan set while calling out the type of material that will be used to install the UFL (i.e., 149 lineal feet of 4” DIP, etc.) Address these issues when resubmitting.**

2. The applicant shall be aware that the access road hydrant distribution was not planned to address the suppression needs for all commercial properties within this subdivision; this site requires the addition of one hydrant (to be located at the s/e corner island of the building... as required per NFPA 24 Section 7.2.3. The hydrant shall be located within 40 feet of the building to be served. Once a site plan, that meets the requirements of the fire code, has been deemed acceptable, the fire hydrant location will be addressed more fully. **Satisfied; the utility drawings indicate that the fire hydrant has been addressed and located per NFPA 24 Section 7.2.3.**
3. The applicant shall be aware that **no vertical construction on this site will be allowed until such time that curb gutter and first lift of asphalt are installed**; a site inspection will be required to ensure that this requirement is made prior to allowing vertical construction to commence. **Satisfied; the applicant has acknowledged that vertical construction will not be permitted until curb/gutter and first life of asphalt has been installed. Note – A site inspection is required before the building will be allowed to go vertical. Foundation, and in-ground infrastructure shall be allowed to be installed as well while the site is being improved.**
4. Once a site plan is provided that satisfies the intent of the code, the applicant shall provide an auto turn analysis indicating that apparatus can navigate all portions of this site. **Satisfied; the applicant has addressed this issue with the second submittal.**
5. The applicant shall provide NO PARKING – FIRE LANE signage for any portion of the access where the 24-foot clear width requirement cannot be met; areas that are required to have this signage are located on both the north and sides of the building. See below for areas highlighted in yellow: **Not satisfied; see below for locations specific to NO PARKING – FIRE LANE signage. Provided double arrows in all cases and address when resubmitting:**

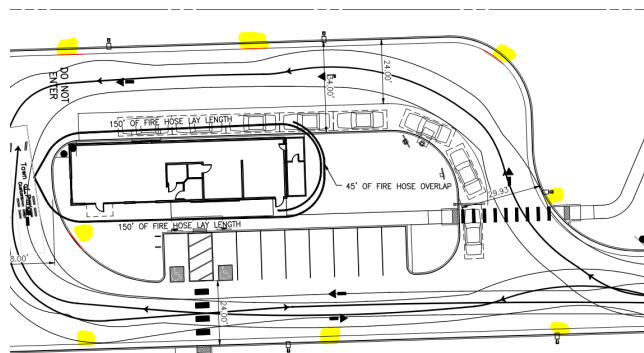

Note - The Town of Parker requires that fire apparatus access roads meet the clear-width and weight-bearing standards of the jurisdiction in which the project is located. Roadways shall be designed to support the imposed weight of fire apparatus, 30-ton, two axle and 40-ton, three axle vehicles. An unimpeded clear width of 24-feet shall be maintained at all times. As such, any location where parked vehicles would obstruct this clear width requirement will require "NO PARKING – FIRE LANE" signage. *This signage shall be red on white. Design criteria has been provided at the end of this document; ensure compliance when resubmitting.*

Note - An attempt to contact John, with Ethos Architecture Group was made to discuss the site plan on 06.27.22 at approximately 2:30 in the afternoon.

GENERAL COMMENTS (as applicable)

All engineering documents submitted to the Town of Parker shall bear the wet signature and seal of the engineer or architect in responsible charge of the design.

Water distribution and site access components shall be installed and in service prior to the construction of any portion of the structure, except by special permit issued by the Fire District.

Underground fire lines

When thrust blocks are used as part of the pipe restraint system, submitted plans for permit shall provide detailed documentation that the thrust blocks satisfy all requirements of 19 NFPA 24: 10.8.2, including specific thrust block dimensions and mathematical calculations for block dimensions per guidelines provided in Annex A.10.8.2.

FIRE ACCESS ROAD DESIGN CRITERIA

VEHICLE SPECIFICATIONS are provided for the largest apparatus in use by South Metro Fire Rescue. Fire Apparatus Access Roads shall be capable of accommodating this apparatus.

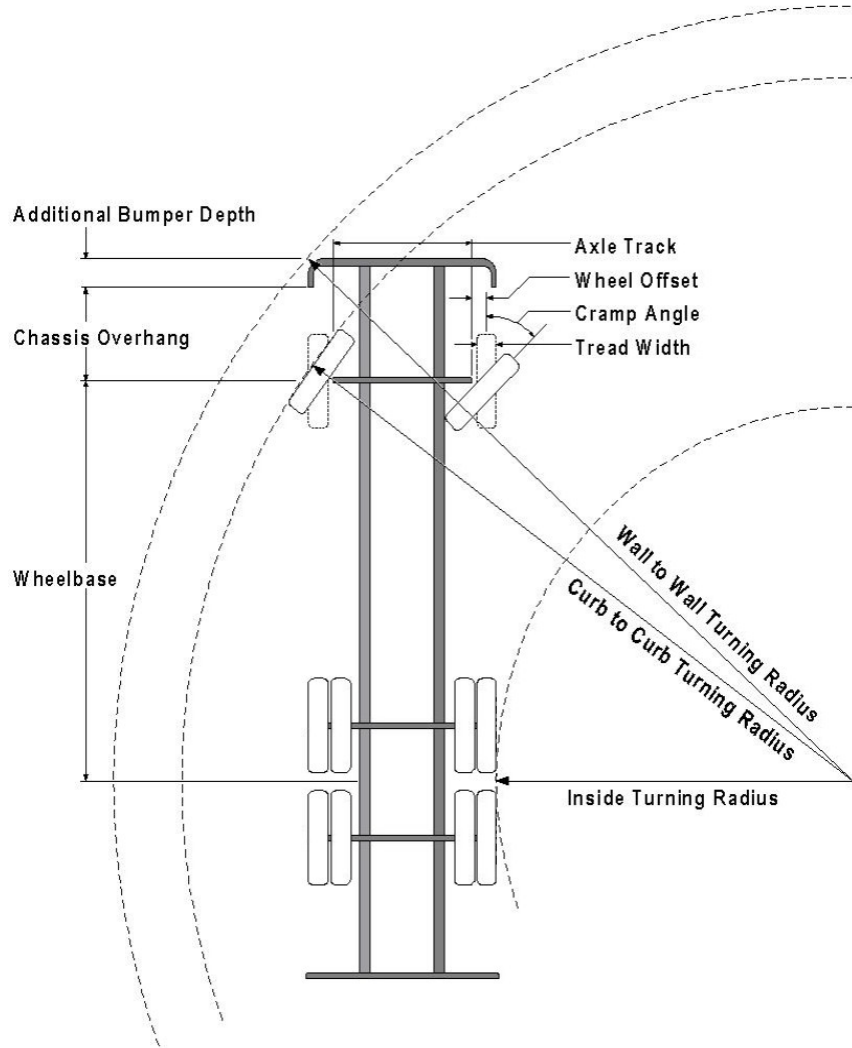
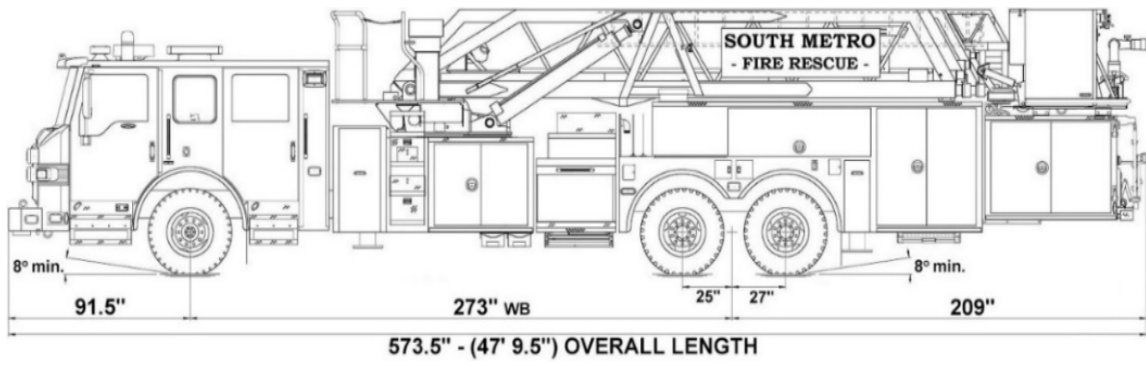

Vehicle Specifications

Length: 47' 9.5"

Width: 8' 5" - (10' 1" mirror to mirror)

Height: 10' 9"

Wheelbase: 273 in.

Design load: 80,000 pounds

Inside Cramp Angle: 40°

Axle Track: 83"

Wheel Offset: 5.3"

Tread Width: 13.5"

Turning Radii:

Inside Turn: 26 ft. 1 in.

Curb to curb: 41 ft. 11 in.

Wall to wall: 46 ft. 8 in.

Where objects are present adjacent to the fire apparatus access road, particularly on turns and turn arounds which require backing, a reasonable safety margin shall be provided to prevent potential damage to the property and to the fire apparatus.

PRIVATE ROADS that provide access to more than two dwellings or one or more commercial buildings shall be constructed to meet the roadway standards approved by the South Metro Fire Rescue Authority for fire apparatus access. Private roads that do not meet the roadway standard may be accepted provided that alternative methods and materials are incorporated into the subdivision that addresses the fire and life safety of the citizens.

Underground Fire Line - Submittal Requirements

Reference: 2019 NFPA 24 [Installation of Private Fire Service Mains and Their Appurtenances](#)

A separate permit is required and will be issued pending review of a detailed submittal which must include the following:
[21 IFC 901.2]

4.1.1 Working plans shall be submitted for approval to the authority having jurisdiction before any equipment is installed or replaced.

4.1.2 Deviation from approved plans shall require permission of the authority having jurisdiction.

4.1.3 Working plans shall be drawn to an indicated scale on sheets of uniform size, with a plan of each floor as applicable, and shall include the following items that pertain to the design of the system:

- (1) Name of owner
- (2) Location, including street address
- (3) Point of compass
- (4) A graphic representation of the scale used on all plans
- (5) Name and address of contractor
- (6) Size and location of all water supplies
- (7) The following items that pertain to private fire service mains:
 - (a) Size
 - (b) Length
 - (c) Location
 - (d) Material (ductile-iron, PVC., etc.)
 - (e) Point of connection to city main

- (f) Sizes, types, and locations of valves, depth at which the top of the pipe is laid below grade
- (g) Method of restraint (Meg-a-Lug or similar)

4.1.4 The working plan submittal shall include the manufacturer's installation instructions for any specially listed equipment, including descriptions, applications, and limitations for any devices, piping, or fittings. Submittals must include installation specifications for thrust blocks, corrosion protection, restraint system, bedding, detail of pipe under the building up to, and including, the flange. When it is intended that a different contractor will extend the fire line from a stopping point outside the building, to the inside flange, a second submittal and permit is required.

All tees, plugs, reducers, valves, and hydrant branches shall be restrained against movement by thrust blocks [10.8.2] or restrained joint systems [10.8.3]. When thrust blocks are used as part of the pipe restraint system, submitted plans shall provide detailed documentation that the thrust blocks satisfy all requirements of Section 10.8.2, including specific thrust block dimensions and mathematical calculations for block dimensions per guidelines provided in Annex A.10.8.2.

Any individual or company who physically works on or installs any part of a fire suppression system, including underground supply lines, from public water lines to system risers and backflow preventers, **must** be registered with the Colorado Division of Fire Safety. [Dept of Public Safety, Division of Fire Safety, Fire Suppression Program 8 CCR 1507-11:3.1.2] Documentation of valid annual registration may be required with plan submittal.

The following website for the Colorado Division of Fire Safety will provide registration instructions.

<http://dfs.state.co.us/SuppAppsProclnsp.htm>

All submittals must display a wet stamp and original signature by a Colorado licensed professional engineer or NICET III, or higher, in fire suppression systems. [Dept. of Public Safety, Division of Fire Safety, Fire Suppression Program 8 CCR 1507

FIRE CODE REVIEW BLOCK

All fire hydrants shall be installed according to water utility standards. The number and locations of the fire hydrants as shown on the Overall Utility Plan are correct as specified by the Town of Parker, Community Development Department.

Fire Code Official or Designated Representative

Date

(NOTE - Underground Fire Line (UFL) submittal documents must meet the requirements of NFPA 24 when submitting for review.)