

May 13, 2022

Department of Parks and Recreation
Town of Parker
20120 Mainstreet
Parker, CO 80138

**RE: Harvie Open Space Park
Drainage Letter**

To the Department of Parks and Recreation,

The Harvie Open Space Park project proposes to develop non-paved trails and several shelters on currently undeveloped land. The park is to be developed on a parcel of land, owned by the Town of Parker, just north of the intersection of Canterbury Parkway and East Mainstreet. The parcel of land is 71.459 acres and is subject to a conservation easement (No. 9608486). Other than an old farmstead with appurtenances, in disrepair, in the easterly portion of the site, the property is undeveloped. Said Parcel of land is bordered by Mainstreet to the south, Pope Road to the east, The Quail Creek Subdivision to the west and the Homestead Hills Subdivision and private agricultural lands to the north.

The proposed park disturbed area is approximately 4.0 acres of the 71.459 acre site. Historically stormwater runoff drains from north to south through the site, with the drainage basin extending north of the subject property down to East Mainstreet. The proposed developed trails and shelters were designed to minimize drainage basin impact and will not change the overall outfall locations of the site. Only minor drainage basin changes will occur within the main, historic, drainage basin A0. See drainage map for outfall location and details.

Soils Present within the boundaries of the park are identified by the United States Department of Agriculture Natural Resource Conservation Services to include Bresser-Truckton sandy loams and Stapleton-Bresser association

Bresser-Truckton sandy loams (BtE) covers 55.7% of the site. Classified as a hydrologic type B soil, Bresser-Truckton yields a medium runoff.

Soil Composition:

- Bresser, 50% of parent soil, is classified as hydrologic soil group B.
- Truckton, 35% of parent soil, is classified as hydrologic soil group A.
- 15% of the soil is made up of minor components. Soils less than 5%.

Stapleton-Bresser association (St) covers 44.3% of the site. Classified as a hydrologic type B soil, Stapleton-Bresser association yields a medium runoff.

Soil Composition:

- Stapleton, 60% of the parent soil, is classified as hydrologic soil group A.
- Bresser, 25% of the parent soil, is classified as hydrologic soil group B.
- 15% of the soil is made up of minor components.

See soils map and soils report documents for additional information.

The proposed site is covered by Statewide MS4 Permit C0R090000 Part 1.E.4, Post-Construction Stormwater Management in New Development & Redevelopment. All trails within the park are exempt

Westwood

10333 E DRY CREEK RD.
SUITE 240
ENGLEWOOD, CO 80112
TEL: 720.482.9526
Westwoodps.com
Westwood Professional Services, Inc.

per Part 1.E.4.a.i.(I) *Trials*. The non-trail, impervious areas, concrete pads, stairs and shelter areas fall under Part 1.E.4.a.i.(F), *Non-Residential and Non-Commercial Infiltration Conditions*.

Section 4.a.i.(F) requires that the completed project, impervious areas, do not produce concentrated stormwater flow nor produce discharge from the 80th percentile stormwater runoff. Per the Urban Drainage and Flood Control District's Urban Storm Drainage Criteria Manual, Volume 3, Table 3-1, Table 3-1, Number of Rainfall Events in the Denver Area, indicated that the 80th percentile of runoff producing storm, produces less than 0.6 inches (~5/8 of an inch) of rainfall. See attached USDCM Table 3-1.

There are three shelter areas proposed on site. These shelters utilize crusher fines as a surface and the roof is an open topped frame system with no proposed walls. These structures and associated areas were designed to minimize runoff impact and as such, no runoff calculations were performed regarding these areas (Assumed negligible drainage changes).

The proposed parking area located along the southern boundary of the site is primarily gravel with asphalt transitions to the existing Mainstreet road and concrete for ADA parking stall and loading area. The breakdown of the parking areas is as follows:

- Total Area: 13,010 S.F.
- Gravel: 10,857 S.F.
- Asphalt: 1,696 S.F.
- Concrete: 457 S.F.

Considering that the majority of the parking area is pervious and that the parking area includes less than 0.5% of the total property, no calculation were performed regarding the negligible change to runoff volume.

The parking area for the open space is proposed around the current, existing type c inlet, designated drainage basin A0 (Design Point 1). Per Stanley Consultants, Inc., Harvie Open Space Access Improvements DRAINAGE MEMORANDUM, (Dated March 16, 2018) the existing type c inlet and 24" conveyance pipe is capable of carrying 35.7 cfs. In order to maintain the existing drainage patterns and to reduce the amount of runoff crossing the parking lot area during storm events, this letter proposes to leave the existing system, type c inlet and 24" drainage pipe, in place and extend the line an additional 167 feet to a single new Type D inlet in sump located at Design Point 2 (Basin A1). This new Type D inlet was designed to intercept both the minor (5-yr) and major (100-yr) storm events. The proposed inlet is designed with to have 0.5 feet of depth to capture the 5-yr storm event, and 3.2 feet of depth in the 100-yr event. See SF-3 Standard Form for details.

Drainage Basin A1.1, outlets at Design Point 3, where a proposed pedestrian bridge is to be set. Given the 26.3 cfs required to pass under said bridge for the 100-yr storm, a trapezoidal cross section with a bottom width of 3 feet, side slopes of 4:1 and a depth of 1 foot is adequate to pass the required flow (See *Trapezoidal Channel Calculations – "Channel Report"* for details).

Design Points 4 through 10 have a discharge of 3.1 cfs or less (see SF-3 100yr Form for details). An 18 inch HDPE culvert at each crossing is more than adequate to protect the trail from erosion during a 100-yr storm even. Each 18 inch culvert outlet is to be protected by UDFCD Riprap Type VL, utilizing a 3 foot wide by 5 foot long area (assumes elevation of culvert outlet at riprap grade). Trail crossings further upstream of these design points are proposed as sheet flow crossing (no culvert improvements are anticipated).

If there are any questions regarding this letter, please do not hesitate to contact me at 720.249.3575.

Sincerely,

Thomas J. Odle, PE
Sr. Project Manager

Attached:

<i>Document Name</i>	<i>(# of Pages)</i>
• <i>Table 3-1. Number of Rainfall Event in the Denver Area (USDCM).....</i>	<i>(1)</i>
• <i>Table 5.1 One-Hour Point Rainfall, Town of Parker Storm Drainage and Environmental Criterial Manual.....</i>	<i>(1)</i>
• <i>USDA Soils Map and Soils Report.....</i>	<i>(8)</i>
• <i>Sub-Basin Drainage Map.....</i>	<i>(1)</i>
• <i>Standard Form SF-1.....</i>	<i>(1)</i>
• <i>Standard Form SF-2.....</i>	<i>(1)</i>
• <i>Standard Form SF-3 5-yr.....</i>	<i>(1)</i>
• <i>Standard Form SF-3 100-yr.....</i>	<i>(1)</i>
• <i>Culvert Stage-Discharge Sizing Worksheet.....</i>	<i>(1)</i>
• <i>Culvert Headwater and Outlet Protection Worksheet.....</i>	<i>(1)</i>
• <i>Trapezoidal Channel Calculations – “Channel Report”.....</i>	<i>(2)</i>
• <i>Type C Inlet Calculations.....</i>	<i>(2)</i>

Table 3-1. Number of Rainfall Events in the Denver Area
(Adapted from Urbonas et al. 1989)

Total Rainfall Depth (inches)	Average Annual Number of Storm Events	Percent of Total Storm Events	Percentile of Runoff-producing Storms
0.0 to 0.1	46	61.07%	0.00%
0.1 to 0.5	22	29.21%	75.04%
≤ 0.6	69	91.61%	80.00%
0.5 to 1.0	4.7	6.24%	91.07%
1.0 to 1.5	1.5	1.99%	96.19%
1.5 to 2.0	0.6	0.80%	98.23%
2.0 to 3.0	0.3	0.40%	99.26%
3.0 to 4.0	0.19	0.25%	99.90%
4.0 to 5.0	0.028	0.04%	100.00%
> 5.0	0	0.00%	100.00%
TOTAL:	75	100%	100%

TABLE 5.1
ONE-HOUR POINT RAINFALL

Frequency of Design Event (yr)	One-hour Point Rainfall, P₁ (in)
2	0.99
5	1.39
10	1.64
25	1.98
50	2.31
100	2.60

Soil Map—Castle Rock Area, Colorado
(Harvie Park Open Space)



Soil Map may not be valid at this scale.

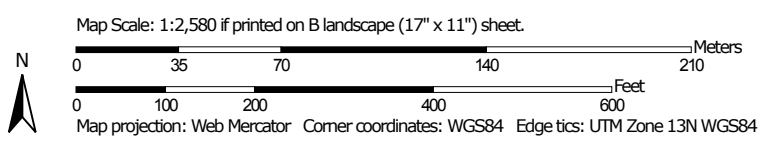

Soil Map—Castle Rock Area, Colorado
(Harvie Park Open Space)

MAP LEGEND

Area of Interest (AOI)

 Area of Interest (AOI)

Soils

 Soil Map Unit Polygons

 Soil Map Unit Lines

 Soil Map Unit Points

Special Point Features



Blowout



Borrow Pit



Clay Spot



Closed Depression



Gravel Pit



Gravelly Spot



Landfill



Lava Flow



Marsh or swamp



Mine or Quarry



Miscellaneous Water



Perennial Water



Rock Outcrop



Saline Spot



Sandy Spot



Severely Eroded Spot



Sinkhole



Slide or Slip



Sodic Spot



Spoil Area



Stony Spot



Very Stony Spot



Wet Spot



Other



Special Line Features

Water Features



Streams and Canals

Transportation



Rails



Interstate Highways



US Routes



Major Roads



Local Roads

Background



Aerial Photography

MAP INFORMATION

The soil surveys that comprise your AOI were mapped at 1:20,000.

Warning: Soil Map may not be valid at this scale.

Enlargement of maps beyond the scale of mapping can cause misunderstanding of the detail of mapping and accuracy of soil line placement. The maps do not show the small areas of contrasting soils that could have been shown at a more detailed scale.

Please rely on the bar scale on each map sheet for map measurements.

Source of Map: Natural Resources Conservation Service
Web Soil Survey URL:
Coordinate System: Web Mercator (EPSG:3857)

Maps from the Web Soil Survey are based on the Web Mercator projection, which preserves direction and shape but distorts distance and area. A projection that preserves area, such as the Albers equal-area conic projection, should be used if more accurate calculations of distance or area are required.

This product is generated from the USDA-NRCS certified data as of the version date(s) listed below.

Soil Survey Area: Castle Rock Area, Colorado
Survey Area Data: Version 10, Oct 10, 2017

Soil map units are labeled (as space allows) for map scales 1:50,000 or larger.

Date(s) aerial images were photographed: Mar 16, 2012—Aug 21, 2014

The orthophoto or other base map on which the soil lines were compiled and digitized probably differs from the background imagery displayed on these maps. As a result, some minor shifting of map unit boundaries may be evident.

Map Unit Legend

Map Unit Symbol	Map Unit Name	Acres in AOI	Percent of AOI
BtE	Bresser-Truckton sandy loams, 5 to 25 percent slopes	40.2	55.7%
St	Stapleton-Bresser association	31.9	44.3%
Totals for Area of Interest		72.1	100.0%

Castle Rock Area, Colorado

BtE—Bresser-Truckton sandy loams, 5 to 25 percent slopes

Map Unit Setting

National map unit symbol: jqy9
Elevation: 5,500 to 6,600 feet
Mean annual precipitation: 15 to 19 inches
Mean annual air temperature: 47 to 52 degrees F
Frost-free period: 120 to 135 days
Farmland classification: Not prime farmland

Map Unit Composition

Bresser and similar soils: 50 percent
Truckton and similar soils: 35 percent
Minor components: 15 percent
Estimates are based on observations, descriptions, and transects of the mapunit.

Description of Bresser

Setting

Landform: Terraces
Landform position (three-dimensional): Tread, riser
Down-slope shape: Linear
Across-slope shape: Linear
Parent material: Sandy eolian deposits

Typical profile

H1 - 0 to 8 inches: sandy loam
H2 - 8 to 30 inches: sandy clay loam
H3 - 30 to 60 inches: loamy sand

Properties and qualities

Slope: 5 to 15 percent
Depth to restrictive feature: More than 80 inches
Natural drainage class: Well drained
Runoff class: Medium
Capacity of the most limiting layer to transmit water (Ksat):
Moderately high to high (0.20 to 2.00 in/hr)
Depth to water table: More than 80 inches
Frequency of flooding: None
Frequency of ponding: None
Available water storage in profile: Moderate (about 7.6 inches)

Interpretive groups

Land capability classification (irrigated): None specified
Land capability classification (nonirrigated): 6e
Hydrologic Soil Group: B
Ecological site: Sandy Foothill (R049BY210CO)
Hydric soil rating: No

Description of Truckton

Setting

Landform: Terraces

Landform position (three-dimensional): Tread, riser

Down-slope shape: Linear

Across-slope shape: Linear

Parent material: Alluvium derived from arkosic sedimentary rock

Typical profile

H1 - 0 to 4 inches: sandy loam

H2 - 4 to 19 inches: sandy loam

H3 - 19 to 60 inches: sandy loam

Properties and qualities

Slope: 10 to 25 percent

Depth to restrictive feature: More than 80 inches

Natural drainage class: Well drained

Runoff class: Low

Capacity of the most limiting layer to transmit water (Ksat): High
(2.00 to 6.00 in/hr)

Depth to water table: More than 80 inches

Frequency of flooding: None

Frequency of ponding: None

Available water storage in profile: Low (about 6.0 inches)

Interpretive groups

Land capability classification (irrigated): None specified

Land capability classification (nonirrigated): 6e

Hydrologic Soil Group: A

Hydric soil rating: No

Minor Components

Blakeland

Percent of map unit: 5 percent

Hydric soil rating: No

Newlin

Percent of map unit: 5 percent

Hydric soil rating: No

Stapleton

Percent of map unit: 4 percent

Hydric soil rating: No

Aquic haplustolls

Percent of map unit: 1 percent

Landform: Swales

Hydric soil rating: Yes

Data Source Information

Soil Survey Area: Castle Rock Area, Colorado
Survey Area Data: Version 10, Oct 10, 2017

Castle Rock Area, Colorado

St—Stapleton-Bresser association

Map Unit Setting

National map unit symbol: jr09
Elevation: 5,500 to 6,600 feet
Mean annual precipitation: 15 to 19 inches
Mean annual air temperature: 49 to 51 degrees F
Frost-free period: 120 to 135 days
Farmland classification: Not prime farmland

Map Unit Composition

Stapleton and similar soils: 60 percent
Bresser and similar soils: 25 percent
Minor components: 15 percent
Estimates are based on observations, descriptions, and transects of the mapunit.

Description of Stapleton

Setting

Landform: Ridges, valley sides, knobs
Down-slope shape: Linear
Across-slope shape: Linear
Parent material: Weathered alluvium derived from arkose

Typical profile

H1 - 0 to 7 inches: sandy loam
H2 - 7 to 16 inches: sandy loam
H3 - 16 to 60 inches: gravelly sandy loam, gravelly coarse sandy loam
H3 - 16 to 60 inches:

Properties and qualities

Slope: 8 to 30 percent
Depth to restrictive feature: More than 80 inches
Natural drainage class: Well drained
Runoff class: Low
Capacity of the most limiting layer to transmit water (Ksat):
Moderately high to high (0.60 to 6.00 in/hr)
Depth to water table: More than 80 inches
Frequency of flooding: None
Frequency of ponding: None
Available water storage in profile: High (about 9.6 inches)

Interpretive groups

Land capability classification (irrigated): None specified
Land capability classification (nonirrigated): 6e
Hydrologic Soil Group: A
Ecological site: Sandy Foothill (R049BY210CO)
Hydric soil rating: No

Description of Bresser

Setting

Landform: Valley sides

Down-slope shape: Linear

Across-slope shape: Linear

Parent material: Sandy alluvium and/or sandy eolian deposits

Typical profile

H1 - 0 to 8 inches: sandy loam

H2 - 8 to 30 inches: sandy clay loam

H3 - 30 to 60 inches: loamy sand

Properties and qualities

Slope: 8 to 15 percent

Depth to restrictive feature: More than 80 inches

Natural drainage class: Well drained

Runoff class: Medium

Capacity of the most limiting layer to transmit water (Ksat):

Moderately high to high (0.20 to 2.00 in/hr)

Depth to water table: More than 80 inches

Frequency of flooding: None

Frequency of ponding: None

Available water storage in profile: Moderate (about 7.6 inches)

Interpretive groups

Land capability classification (irrigated): None specified

Land capability classification (nonirrigated): 6e

Hydrologic Soil Group: B

Hydric soil rating: No

Minor Components

Loamy alluvial land

Percent of map unit: 14 percent

Hydric soil rating: No

Aquic haplustolls

Percent of map unit: 1 percent

Landform: Swales

Hydric soil rating: Yes

Data Source Information

Soil Survey Area: Castle Rock Area, Colorado

Survey Area Data: Version 10, Oct 10, 2017

HARVIE OPEN SPACE

TOWN OF PARKER, COLORADO

- NOTES:
- ALL DRAIN INLETS TO BE COVERED USING CLOSE MESH GRATE. SEE CDOT STANDARD M-604-10 FOR TYPE C CLOSE MESH GRATE STANDARDS.
 - SEE IRRIGATION PLANS FOR DETAILED LOCATION OF WATERLINE. WATERLINE TO BE LOWERED WHERE NECESSARY.
 - ADDITIONAL EXISTING UTILITIES TO THE SOUTH OF PROPOSED PARKING LOT MAY EXIST. UTILITY LOCATES TO BE ACQUIRED BEFORE INSTALLATION/GROUND BREAKING MAY COMMENCE.

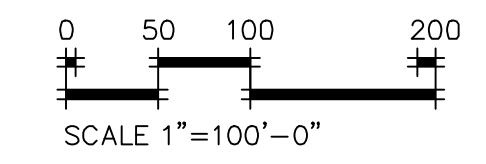

LEGEND

	A = BASIN DESIGNATION B = AREA IN ACRES C = 5 YEAR RUNOFF COEFF. D = 100 YEAR RUNOFF COEFF.
	PROPOSED NATURALIZED WATER CROSSING
	PROPOSED SLOPE
	FLOW ARROW
	PROPOSED CULVERT LOCATION
	DRAINAGE BASIN LIMITS
	EXISTING MINOR CONTOUR
	EXISTING MAJOR CONTOUR
	PROPOSED MAJOR CONTOUR
	PROPOSED MINOR CONTOUR

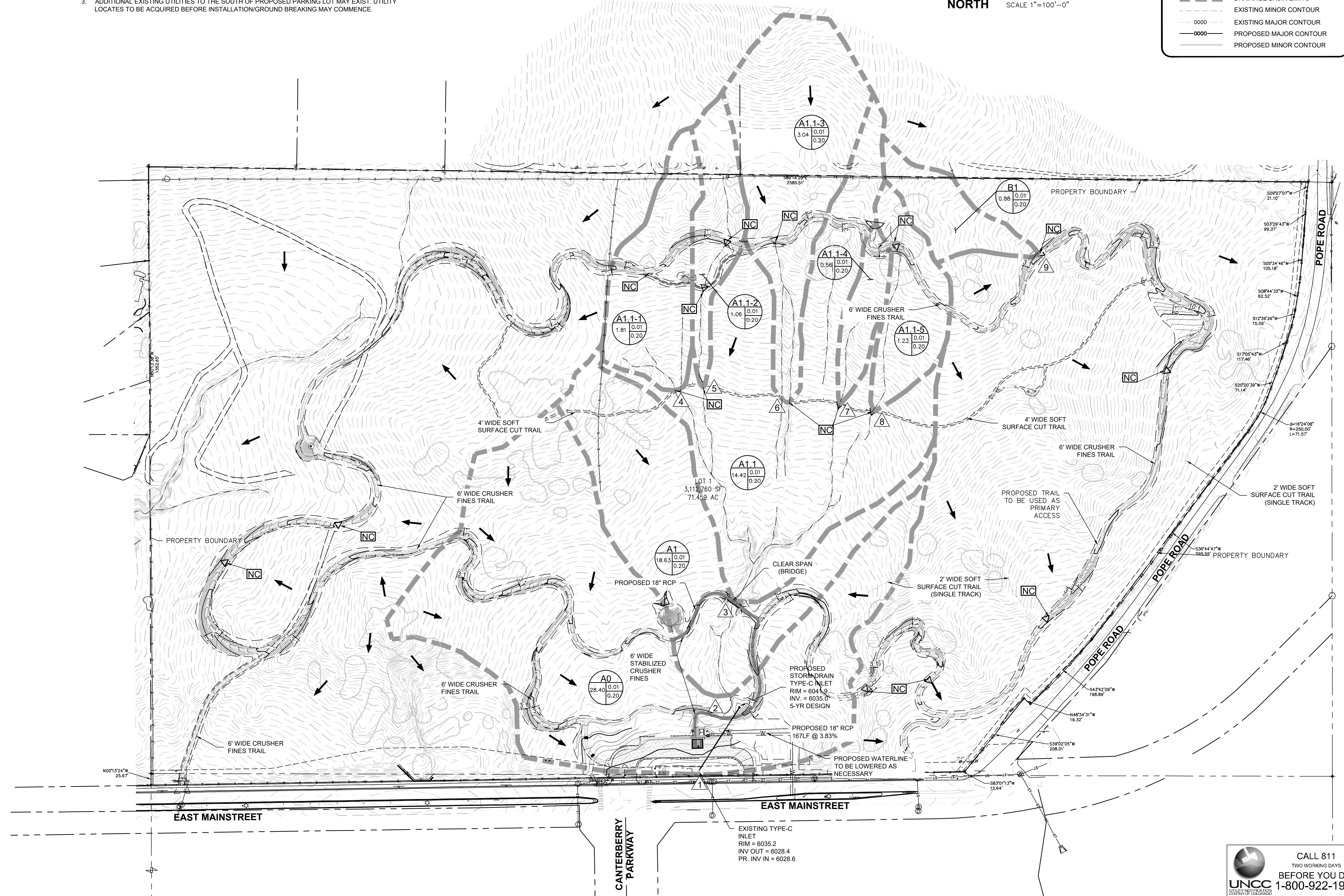

DHM DESIGN
 900 S. Broadway
 Suite 300
 Denver, CO 80209
 303.892.5564
 www.dhmdesign.com

REUSE OF DOCUMENT
 This document is the property of DHM Design Corp. The ideas and design incorporated on this document are instruments of professional service and shall not be used for any other project without written authorization of DHM Design Corp.

Westwood
 10333 E DRY CREEK RD.
 SUITE 240
 ENGLEWOOD, CO 80112
 TEL: 720.482.5526
 Westwoodps.com
 Westwood Professional Services, Inc.

Harvie Open Space Park
 100% CONSTRUCTION DRAWINGS
 20120 East Main Street, Parker, CO 80138

PROJECT NUMBER: 17279.00
 DATE: 01.15.2019
 DESIGNED: CUB
 DRAWN: CUB
 CHECKED: TJO

REVISIONS:
 JOB DESCRIPTION:
 100% CONSTRUCTION DOCUMENTS

SHEET TITLE:
 DRAINAGE BASIN MAP

SCALE: 1" = 100'
 SHEET NUMBER:

D1.0

CALL 811
 TWO WORKING DAYS
 BEFORE YOU DIG
UNCC
 1-800-922-1987

PREPARED UNDER THE SUPERVISION OF
 THOMAS J. ODLE
 COLORADO P.E. 52802

SF-1 SUB-BASIN SUMMARY
COMPOSITE C AND IMPERVIOUS VALUES

Harvie Park _____

Project Name: Harvie Park
Project No. 8.13.0308201
Calculated By: CUB

Land Use Assumptions,

Note: Per USDA Web Soil Survey, Hydrologic Soil Group B is conservative.

Note: Runoff Coefficients from UDFCD Vol. 1 Table 6-5, *Runoff Coefficients*

Land Use	Imp.	C ₂	C ₅	C ₁₀₀
Openspace	2%	0.01	0.01	0.44

A1

Total Area		18.63 acres				
Land Use	Imp.	C ₂	C ₅	C ₁₀₀	Area	Imp%
Openspace	2%	0.01	0.01	0.44	18.63	2.0
TOTAL					18.63	2.0

A1

A1.1

Total Area		14.42 acres				
Land Use	Imp.	C ₂	C ₅	C ₁₀₀	Area	Imp%
Openspace	2%	0.01	0.01	0.44	14.42	2.0
TOTAL					14.42	2.0

A1.1

A1.1-1

Total Area		1.44 acres				
Land Use	Imp.	C ₂	C ₅	C ₁₀₀	Area	Imp%
Openspace	2%	0.01	0.01	0.44	1.44	2.0
TOTAL					1.44	2.0

A1.1-1

A1.1-2

Total Area		0.37 acres				
Land Use	Imp.	C ₂	C ₅	C ₁₀₀	Area	Imp%
Openspace	2%	0.01	0.01	0.44	0.37	2.0
TOTAL					0.37	2.0

A1.1-2

A1.1-3

Total Area		1.06 acres				
Land Use	Imp.	C ₂	C ₅	C ₁₀₀	Area	Imp%
Openspace	2%	0.01	0.01	0.44	1.06	2.0
TOTAL					1.06	2.0

A1.1-3

A1.1-4

Total Area		3.04 acres				
Land Use	Imp.	C ₂	C ₅	C ₁₀₀	Area	Imp%
Openspace	2%	0.01	0.01	0.44	3.04	2.0
TOTAL					3.04	2.0

A1.1-4

A1.1-5

Total Area		0.56 acres				
Land Use	Imp.	C ₂	C ₅	C ₁₀₀	Area	Imp%
Openspace	2%	0.01	0.01	0.44	0.56	2.0
TOTAL					0.56	2.0

A1.1-5

A1.1-6

Total Area		1.23 acres				
Land Use	Imp.	C ₂	C ₅	C ₁₀₀	Area	Imp%
Openspace	2%	0.01	0.01	0.44	1.23	2.0
TOTAL					1.23	2.0

A1.1-6

B1

Total Area		0.88 acres				
Land Use	Imp.	C ₂	C ₅	C ₁₀₀	Area	Imp%
Openspace	2%	0.01	0.01	0.44	0.88	2.0
TOTAL					0.88	2.0

B1

A0

Total Area		28.40 acres				
Land Use	Imp.	C ₂	C ₅	C ₁₀₀	Area	Imp%
Openspace	2%	0.01	0.01	0.44	28.40	2.0
TOTAL					28.40	2.0

A0

SF-2 TIME OF CONCENTRATION FOR EACH SUB-BASIN

SUB-BASIN DATA			INITIAL/OVERLAND TRAVEL TIME							Tc CHECK	FIRST DESIGN POINT				EFFECTIVE
BASIN ID	D.A. (AC)	C ₅	T _i			T _t				T _i + T _T	T _c				T _c
			L FT	S FT/FT	T _i MIN	L FT	S FT/FT	VEL. FPS	T _t MIN	TOTAL Tc MIN	% IMP. DECIMAL	LENGTH FT	SLOPE FT/FT	MIN. T _c MIN.	MIN
A1	18.63	0.01	500	0.08	22.2	1073	0.08	2.0	9.0	31.2	0.02	1573	0.080	35.6	31.2
A1.1	14.42	0.01	500	0.08	22.2	845	0.08	2.0	7.1	29.3	0.02	1345	0.080	34.2	29.3
A1.1-1	1.44	0.01	500	0.09	21.3	117	0.09	2.1	0.9	22.2	0.02	617	0.090	29.4	22.2
A1.1-2	0.37	0.01	433	0.09	19.8	0	0.09	2.1	0.0	19.8	0.02	433	0.090	28.3	19.8
A1.1-3	1.06	0.01	500	0.08	22.2	148	0.08	2.0	1.2	23.4	0.02	648	0.080	29.8	23.4
A1.1-4	3.04	0.01	500	0.08	22.2	371	0.08	2.0	3.1	25.3	0.02	871	0.080	31.2	25.3
A1.1-5	0.56	0.01	417	0.10	18.8	0	0.10	2.2	0.0	18.8	0.02	417	0.100	28.0	18.8
A1.1-6	1.23	0.01	500	0.08	22.2	38	0.08	2.0	0.3	22.5	0.02	538	0.080	29.1	22.5
B1	0.88	0.01	378	0.09	18.5	0	0.09	2.1	0.0	18.5	0.02	378	0.090	27.9	18.5
A0	28.40	0.01	500	0.08	22.2	1349	0.08	2.0	11.4	33.5	0.02	1849	0.080	37.4	33.5

SF-3 STANDARD FORM
STORM DRAINAGE SYSTEM DESIGN
(RATIONAL METHOD PROCEDURE)

Subdivision Harvie Park

Project Name: Harvie Park
Project No. 8.13.0308201
Calculated By: CUB

Design Storm 5
100-Year P1 = 1.39 in. (Table 5.1, *One-Hour Point Rainfall*, Town of Parker Storm Drainage and Environmental Criteria Manual)

COMBINED BASINS	DIRECT RUNOFF								TOTAL RUNOFF								STREET		PIPE		TRAVEL TIME			REMARKS
	Design Point	Area Design.	Area (Ac)	Runoff Coeff.	Tc (min)	C ⁿ A (Ac)	I (in/hr)	Q (cfs)	Inlet Type	Q (Intercept)	Q (Curry-On)	Tc (min)	C ⁿ A (Ac)	I (in/hr)	Q (cfs)	Slope (%)	Overland Flow (cfs)	Design Flow (cfs)	Slope (%)	Pipe Size (inches)	Length (ft)	Velocity (fps)	Tt (min)	
A1	2	A1	18.63	0.01	31.2	0.19	2.1	0.4	TRAPAZOIDAL CHANNEL								0.4	8.00						CDOT Type C Area Inlet
A1.1	3	A1.1	14.42	0.01	29.3	0.14	2.2	0.3	CDOT TYPE-C INLET								0.3	8.00	18.0	30.0	8.15	0.061		Design point 3 is a point where the channel narrows to cross under a pedestrian bridge.
A1.1-1	4	A1.1-1	1.44	0.01	22.2	0.01	2.6	0.0	18" CMP								0.0	9.00	18.0	30.0	5.31	0.094		CMP trail crossing
A1.1-2	5	A1.1-2	0.37	0.01	19.8	0.00	2.7	0.0	18" CMP								0.0	9.00	18.0	30.0	7.08	0.071		CMP trail crossing
A1.1-3	6	A1.1-3	1.06	0.01	23.4	0.01	2.5	0.0	18" CMP								0.0	8.00	18.0	30.0	9.96	0.050		CMP trail crossing
A1.1-4	7	A1.1-4	3.04	0.01	25.3	0.03	2.4	0.1	18" CMP								0.1	8.00	18.0	30.0	6.48	0.077		CMP trail crossing
A1.1-5	8	A1.1-5	0.56	0.01	18.8	0.01	2.8	0.0	18" CMP								0.0	10.00	18.0	30.0	7.36	0.068		CMP trail crossing
A1.1-6	9	A1.1-6	1.23	0.01	22.5	0.01	2.6	0.0	18" CMP								0.0	8.00	18.0	30.0	7.42	0.067		CMP trail crossing
B1	10	B1	0.88	0.01	18.5	0.01	2.8	0.0	18" CMP								0.0	9.00	24.0	23.0	13.30	0.029		CMP trail crossing
AO - AI	1	A0	28.40	0.01	33.5	0.28	2.0	0.6	CDOT TYPE-C INLET					0.2			0.2	2.61	24.0	23.0	13.30	0.029		CDOT Type C Area Inlet to remain. New inlet to be installed to the northeast to eliminate additional crossings.

Note: Refer to SewerGEMS Conduit Table for slopes & pipe diameter.
Note: See design sheet for riprap & outlet protection details

SF-3 STANDARD FORM
STORM DRAINAGE SYSTEM DESIGN
(RATIONAL METHOD PROCEDURE)

Subdivision Harvie Park

Project Name: Harvie Park
Project No. 8.13.0308201
Calculated By: CUB

Design Storm 100
100-Year P1 = 2.6 in. (Table 5.1, *One-Hour Point Rainfall*, Town of Parker Storm Drainage and Environmental Criteria Manual)

COMBINED BASINS	DIRECT RUNOFF								TOTAL RUNOFF						STREET		PIPE			TRAVEL TIME			REMARKS	
	Design Point	Area Design.	Area (Ac)	Runoff Coeff.	Tc (min)	C*A (Ac)	I (in/hr)	Q (cfs)	Inlet Type	Q (Intercept)	Q (Curry-On)	Tc (min)	C*A (Ac)	I (in/hr)	Q (cfs)	Slope (%)	Overland Flow (cfs)	Design Flow (cfs)	Slope (%)	Pipe Size (inches)	Length (ft)	Velocity (fps)		Tt (min)
A1	2	A1	18.63	0.44	31.2	8.20	4.0	32.7	TRAPAZOIDAL CHANNEL								32.7	8.00						CDOT Type C Area Inlet
A1.1	3	A1.1	14.42	0.44	29.3	6.34	4.1	26.3	CDOT TYPE-C INLET								26.3	8.00	18.0	30.0	8.15	0.061	Design point 3 is a point where the channel narrows to cross under a pedestrian bridge.	
A1.1-1	4	A1.1-1	1.44	0.44	22.2	0.63	4.8	3.1	18" CMP								3.1	9.00	18.0	30.0	5.31	0.094	CMP trail crossing	
A1.1-2	5	A1.1-2	0.37	0.44	19.8	0.16	5.1	0.8	18" CMP								0.8	9.00	18.0	30.0	7.08	0.071	CMP trail crossing	
A1.1-3	6	A1.1-3	1.06	0.44	23.4	0.47	4.7	2.2	18" CMP								2.2	8.00	18.0	30.0	9.96	0.050	CMP trail crossing	
A1.1-4	7	A1.1-4	3.04	0.44	25.3	1.34	4.5	6.0	18" CMP								6.0	8.00	18.0	30.0	6.48	0.077	CMP trail crossing	
A1.1-5	8	A1.1-5	0.56	0.44	18.8	0.25	5.3	1.3	18" CMP								1.3	10.00	18.0	30.0	7.36	0.068	CMP trail crossing	
A1.1-6	9	A1.1-6	1.23	0.44	22.5	0.54	4.8	2.6	18" CMP								2.6	8.00	18.0	30.0	7.42	0.067	CMP trail crossing	
B1	10	B1	0.88	0.44	18.5	0.39	5.3	2.1	18" CMP								2.1	9.00	24.0	23.0	13.30	0.029	CMP trail crossing	
AO - AI	1	A0	28.40	0.44	33.5	12.50	3.8	47.7	CDOT TYPE-C INLET					15.0			15.0	2.61	24.0	23.0	13.30	0.029	CDOT Type C Area Inlet to remain. New inlet to be installed to the northeast to eliminate additional crossings.	

Note: Refer to SewerGEMS Conduit Table for slopes & pipe diameter.
Note: See design sheet for riprap & outlet protection details

CULVERT STAGE-DISCHARGE SIZING (INLET vs. OUTLET CONTROL WITH TAILWATER EFFECTS)

Project: **Harvie Park Open Space**
 Basin ID: **A1.1-1 thru A1.1-6 & B1**
 Status: _____

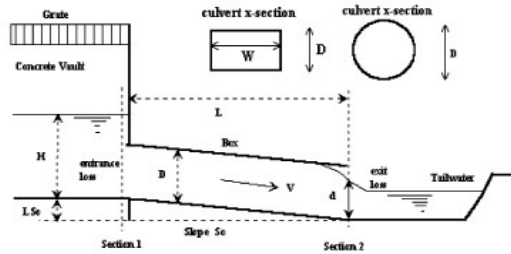

Design Information (Input):

Circular Culvert: Barrel Diameter in Inches D = inches
 Inlet Edge Type (choose from pull-down list)

OR:

Box Culvert: Barrel Height (Rise) in Feet Height (Rise) =
 Barrel Width (Span) in Feet Width (Span) =
 Inlet Edge Type (choose from pull-down list)

Number of Barrels No =
 Inlet Elevation at Culvert Invert Inlet Elev = ft. elev.
 Outlet Elevation at Culvert Invert **OR** Slope of Culvert (ft v./ft h.) Slope = ft vert. / ft horiz.
 Culvert Length in Feet L = ft.
 Manning's Roughness n =
 Bend Loss Coefficient K_b =
 Exit Loss Coefficient K_x =

Design Information (calculated):

Entrance Loss Coefficient K_e =
 Friction Loss Coefficient K_f =
 Sum of All Loss Coefficients K_s =
 Orifice Inlet Condition Coefficient C_d =
 Minimum Energy Condition Coefficient KE_{low} =

Calculations of Culvert Capacity (output):

Water Surface Elevation (ft., linked)	Tailwater Surface Elevation ft	Culvert Inlet-Control Flowrate cfs	Culvert Outlet-Control Flowrate cfs	Controlling Culvert Flowrate cfs (output)	Inlet Equation Used:	Flow Control Used
10.00		0.00	0.00	0.00	No Flow (WS < inlet)	N/A
10.10		0.10	8.69	0.10	Min. Energy. Eqn.	INLET
10.20		0.20	8.96	0.20	Min. Energy. Eqn.	INLET
10.30		0.40	9.23	0.40	Min. Energy. Eqn.	INLET
10.40		0.70	9.48	0.70	Min. Energy. Eqn.	INLET
10.50		1.10	9.72	1.10	Min. Energy. Eqn.	INLET
10.60		1.50	9.96	1.50	Min. Energy. Eqn.	INLET
10.70		2.00	10.20	2.00	Min. Energy. Eqn.	INLET
10.80		2.40	10.43	2.40	Regression Eqn.	INLET
10.90		3.00	10.64	3.00	Regression Eqn.	INLET
11.00		3.50	10.87	3.50	Regression Eqn.	INLET
11.10		4.10	11.08	4.10	Regression Eqn.	INLET
11.20		4.70	11.30	4.70	Regression Eqn.	INLET
11.30		5.30	11.51	5.30	Regression Eqn.	INLET
11.40		5.80	11.70	5.80	Regression Eqn.	INLET
11.50		6.40	11.91	6.40	Regression Eqn.	INLET
11.60		7.00	12.29	7.00	Regression Eqn.	INLET
11.70		7.50	12.67	7.50	Regression Eqn.	INLET
11.80		8.00	13.04	8.00	Regression Eqn.	INLET
11.90		8.50	13.40	8.50	Regression Eqn.	INLET
12.00		8.90	13.74	8.90	Regression Eqn.	INLET
12.10		9.40	14.09	9.40	Regression Eqn.	INLET
12.20		9.80	14.42	9.80	Regression Eqn.	INLET
12.30		10.20	14.74	10.20	Regression Eqn.	INLET
12.40		10.60	15.06	10.60	Regression Eqn.	INLET
12.50		10.90	15.37	10.90	Regression Eqn.	INLET
12.60		11.30	15.67	11.30	Regression Eqn.	INLET
12.70		11.60	15.97	11.60	Regression Eqn.	INLET
12.80		12.00	16.26	12.00	Regression Eqn.	INLET
12.90		12.30	16.55	12.30	Regression Eqn.	INLET

Processing Time: 00.70 Seconds

Determination of Culvert Headwater and Outlet Protection

Project: **Harvie Park Open Space**
 Basin ID: **A1.1-1 Thru A1.1-6 & B1**

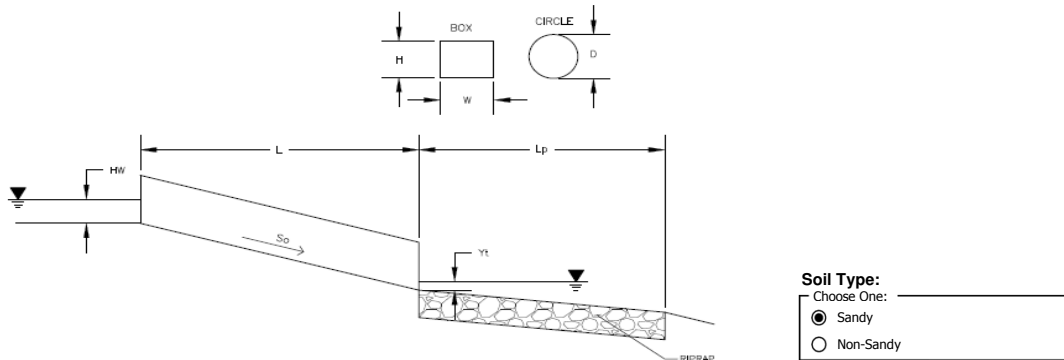

Soil Type:
 Choose One: _____
 Sandy
 Non-Sandy

Supercritical Flow! Using D_a to calculate protection type.

Design Information (Input):	
Design Discharge	Q = <input style="width: 50px;" type="text" value="3.1"/> cfs
Circular Culvert:	
Barrel Diameter in Inches	D = <input style="width: 50px;" type="text" value="18"/> inches
Inlet Edge Type (Choose from pull-down list)	Square End Projection
Box Culvert:	OR
Barrel Height (Rise) in Feet	Height (Rise) = <input style="width: 50px;" type="text"/>
Barrel Width (Span) in Feet	Width (Span) = <input style="width: 50px;" type="text"/>
Inlet Edge Type (Choose from pull-down list)	
Number of Barrels	No = <input style="width: 50px;" type="text" value="1"/>
Inlet Elevation	Elev IN = <input style="width: 50px;" type="text" value="10"/> ft
Outlet Elevation OR Slope	So = <input style="width: 50px;" type="text" value="0.05"/> ft/ft
Culvert Length	L = <input style="width: 50px;" type="text" value="30"/> ft
Manning's Roughness	n = <input style="width: 50px;" type="text" value="0.014"/>
Bend Loss Coefficient	k_b = <input style="width: 50px;" type="text" value="0"/>
Exit Loss Coefficient	k_x = <input style="width: 50px;" type="text" value="1"/>
Tailwater Surface Elevation	Elev Y_t = <input style="width: 50px;" type="text"/>
Max Allowable Channel Velocity	V = <input style="width: 50px;" type="text" value="5"/> ft/s

Required Protection (Output):	
Tailwater Surface Height	Y_t = <input style="width: 50px;" type="text" value="0.60"/> ft
Flow Area at Max Channel Velocity	A_f = <input style="width: 50px;" type="text" value="0.62"/> ft ²
Culvert Cross Sectional Area Available	A = <input style="width: 50px;" type="text" value="1.77"/> ft ²
Entrance Loss Coefficient	k_e = <input style="width: 50px;" type="text" value="0.50"/>
Friction Loss Coefficient	k_f = <input style="width: 50px;" type="text" value="0.63"/>
Sum of All Losses Coefficients	k_s = <input style="width: 50px;" type="text" value="2.13"/> ft
Culvert Normal Depth	Y_n = <input style="width: 50px;" type="text" value="0.38"/> ft
Culvert Critical Depth	Y_c = <input style="width: 50px;" type="text" value="0.67"/> ft
Tailwater Depth for Design	d = <input style="width: 50px;" type="text" value="1.09"/> ft
Adjusted Diameter OR Adjusted Rise	D_a = <input style="width: 50px;" type="text" value="0.94"/> ft
Expansion Factor	$1/(2*\tan(\theta))$ = <input style="width: 50px;" type="text" value="6.70"/>
Flow/Diameter ^{2.5} OR Flow/(Span * Rise ^{1.5})	$Q/D^{2.5}$ = <input style="width: 50px;" type="text" value="1.12"/> ft ^{0.5} /s
Froude Number	Fr = <input style="width: 50px;" type="text" value="2.96"/> Supercritical!
Tailwater/Adjusted Diameter OR Tailwater/Adjusted Rise	Y_t/D = <input style="width: 50px;" type="text" value="0.64"/>
Inlet Control Headwater	HW_i = <input style="width: 50px;" type="text" value="0.93"/> ft
Outlet Control Headwater	HW_o = <input style="width: 50px;" type="text" value="-0.31"/> ft
Design Headwater Elevation	HW = <input style="width: 50px;" type="text" value="10.93"/> ft
Headwater/Diameter OR Headwater/Rise Ratio	HW/D = <input style="width: 50px;" type="text" value="0.62"/>
Minimum Theoretical Riprap Size	d_{50} = <input style="width: 50px;" type="text" value="2"/> in
Nominal Riprap Size	d_{50} = <input style="width: 50px;" type="text" value="6"/> in
UDFCD Riprap Type	Type = <input style="width: 50px;" type="text" value="VL"/>
Length of Protection	L_p = <input style="width: 50px;" type="text" value="5"/> ft
Width of Protection	T = <input style="width: 50px;" type="text" value="3"/> ft

Channel Report

Harvie Park Open Space

Trapezoidal

Bottom Width (ft) = 3.00
Side Slopes (z:1) = 4.00, 4.00
Total Depth (ft) = 2.00
Invert Elev (ft) = 10.00
Slope (%) = 3.00
N-Value = 0.030

Highlighted

Depth (ft) = 0.60
Q (cfs) = 15.28
Area (sqft) = 3.24
Velocity (ft/s) = 4.72
Wetted Perim (ft) = 7.95
Crit Depth, Yc (ft) = 0.69
Top Width (ft) = 7.80
EGL (ft) = 0.95

Calculations

Compute by: Q vs Depth
No. Increments = 10

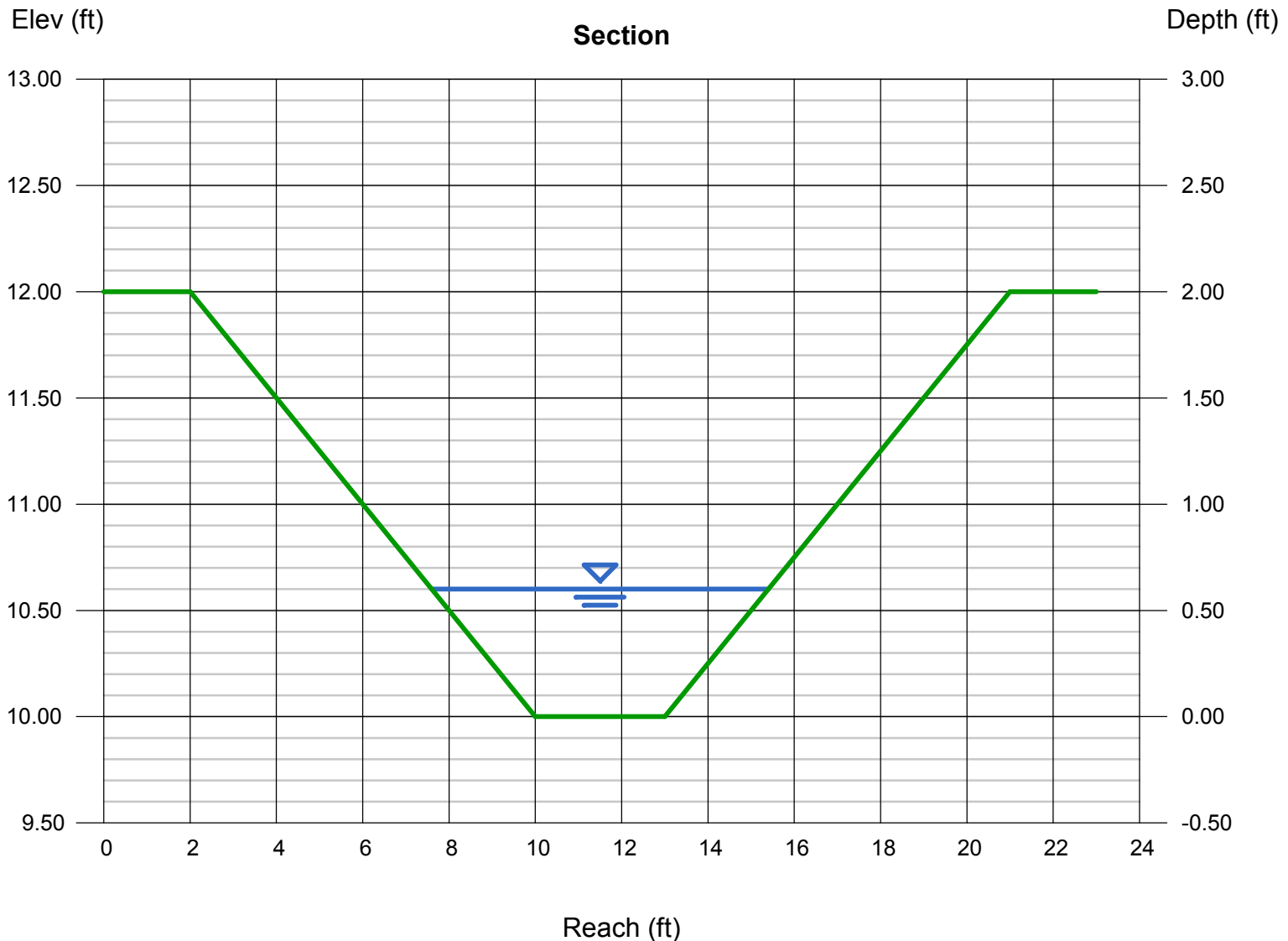

Channel Report

Depth	Q	Area	Veloc	Wp	Yc	Top Width	Energy
(ft)	(cfs)	(sqft)	(ft/s)	(ft)	(ft)	(ft)	(ft)
0.20	1.95	0.76	2.56	4.65	0.22	4.60	0.30
0.40	6.95	1.84	3.78	6.30	0.45	6.20	0.62
0.60	15.28	324.00	4.72	7.95	0.69	7.80	0.95
0.80	27.40	4.96	5.52	9.60	0.93	9.40	1.27
1.00	43.77	7.00	6.25	11.25	1.18	11.00	1.61

AREA INLET IN A SWALE

TYPE D DP2

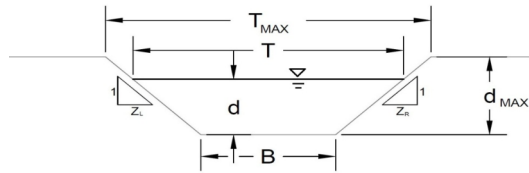

This worksheet uses the NRCS vegetative retardance method to determine Manning's n.
For more information see Section 7.2.3 of the USDCM.

Analysis of Trapezoidal Grass-Lined Channel Using SCS Method			A, B, C, D, or E = A									
NRCS Vegetal Retardance (A, B, C, D, or E)			n = see details below									
Manning's n (Leave cell D16 blank to manually enter an n value)			S ₀ = 0.0050 ft/ft									
Channel Invert Slope			B = 3.00 ft									
Bottom Width			Z ₁ = 6.00 ft/ft									
Left Side Slope			Z ₂ = 6.00 ft/ft									
Right Side Slope			Choose One: <input type="checkbox"/> Non-Cohesive <input checked="" type="checkbox"/> Cohesive <input type="checkbox"/> Paved									
Check one of the following soil types:												
Soil Type:	Max. Velocity (V _{MAX})	Max Froude No. (F _{MAX})										
Non-Cohesive	5.0 fps	0.60										
Cohesive	7.0 fps	0.80										
Paved	N/A	N/A										
Maximum Allowable Top Width of Channel for Minor & Major Storm			<table border="1" style="display: inline-table; border-collapse: collapse;"> <tr> <td style="padding: 2px;">T_{MAX} =</td> <td style="padding: 2px;">20.00</td> <td style="padding: 2px;">35.00</td> <td style="padding: 2px;">ft</td> </tr> <tr> <td style="padding: 2px;">d_{MAX} =</td> <td style="padding: 2px;">0.50</td> <td style="padding: 2px;">3.20</td> <td style="padding: 2px;">ft</td> </tr> </table>		T _{MAX} =	20.00	35.00	ft	d _{MAX} =	0.50	3.20	ft
T _{MAX} =	20.00	35.00	ft									
d _{MAX} =	0.50	3.20	ft									
Maximum Allowable Water Depth in Channel for Minor & Major Storm												
Allowable Channel Capacity Based On Channel Geometry												
MINOR STORM Allowable Capacity is based on Depth Criterion			<table border="1" style="display: inline-table; border-collapse: collapse;"> <tr> <td style="padding: 2px;">Q_{allow} =</td> <td style="padding: 2px;">0.5</td> <td style="padding: 2px;">18.7</td> <td style="padding: 2px;">cfs</td> </tr> <tr> <td style="padding: 2px;">d_{allow} =</td> <td style="padding: 2px;">0.50</td> <td style="padding: 2px;">2.67</td> <td style="padding: 2px;">ft</td> </tr> </table>		Q _{allow} =	0.5	18.7	cfs	d _{allow} =	0.50	2.67	ft
Q _{allow} =	0.5	18.7	cfs									
d _{allow} =	0.50	2.67	ft									
MAJOR STORM Allowable Capacity is based on Top Width Criterion												
Water Depth in Channel Based On Design Peak Flow												
Design Peak Flow			<table border="1" style="display: inline-table; border-collapse: collapse;"> <tr> <td style="padding: 2px;">Q_o =</td> <td style="padding: 2px;">0.4</td> <td style="padding: 2px;">32.7</td> <td style="padding: 2px;">cfs</td> </tr> <tr> <td style="padding: 2px;">d =</td> <td style="padding: 2px;">0.43</td> <td style="padding: 2px;">3.18</td> <td style="padding: 2px;">ft</td> </tr> </table>		Q _o =	0.4	32.7	cfs	d =	0.43	3.18	ft
Q _o =	0.4	32.7	cfs									
d =	0.43	3.18	ft									
Water Depth												
Minor storm max. allowable capacity GOOD - greater than the design flow given on sheet 'Inlet Management' WARNING: MAJOR STORM max. allowable capacity is less than the design flow given on sheet 'Inlet Management'												

MHFD-Inlet, Version 5.01 (April 2021)
AREA INLET IN A SWALE

TYPE D DP2

Inlet Design Information (Input)

Type of Inlet: Inlet Type =

Angle of Inclined Grate (must be ≤ 30 degrees) $\theta = 30.00$ degrees

Width of Grate $W = 3.00$ ft

Length of Grate $L = 3.00$ ft

Open Area Ratio $A_{RATIO} = 0.70$

Height of Inclined Grate $H_B = 1.50$ ft

Clogging Factor $C_f = 0.50$

Grate Discharge Coefficient $C_d = 0.77$

Orifice Coefficient $C_o = 0.52$

Weir Coefficient $C_w = 1.65$

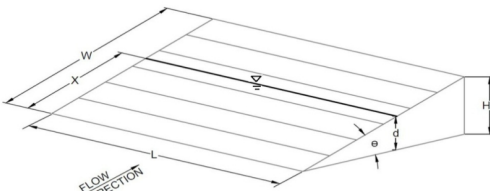

Water Depth at Inlet (for depressed inlets, 1 foot is added for depression)

	MINOR	MAJOR	
$d =$	1.43	4.18	
$Q_a =$	12.8	32.9	cfs
$Q_b =$	0.0	0.0	cfs
$C\% =$	100	100	%

Total Inlet Interception Capacity (assumes clogged condition)

Bypassed Flow

Capture Percentage = Q_a/Q_o

Warning 06: Top Width (T) exceeds max allowable top width (Tmax).

Profile Report

Engineering Profile - 100-yr Proposed Storm Extension (SewerGems2022.stsw)

