

---

# Drainage Compliance Letter

**Kum & Go #2293**

**Trails at Crowfoot Filing No. 9, 1<sup>st</sup>  
Amendment  
LOT 1  
Parker, Colorado**

**July 12, 2023**

---

Prepared For:

## **Kum & Go LC**

1459 Grand Avenue  
Des Moines, IA 50309  
Contact: Dan Garneau  
Email : dan.garneau@kumandgo.com  
Phone: 515-457-6392

---

Prepared By:



3801 E. Florida Avenue, Suite 425  
Denver, CO 80210  
303-572-7997 [www.ees.us.com](http://www.ees.us.com)

Contact: Krysta M. Houtchens, PE  
Email: [krysta.houtchens@ees.us.com](mailto:krysta.houtchens@ees.us.com)

---



SHAKE SHACK AT LOT 3, INTERQUEST FILING NO. 11

**ENGINEER'S STATEMENT**

This Drainage Conformance Letter for Lot 1 (Kum and Go #2293), of Tails at Crowfoot Filing No. 9, 1<sup>st</sup> Amendment, was prepared by me or under my direct supervision in accordance with the provisions of the Town of Parker Storm Drainage & Environmental Criteria Manual. I understand that the Town of Parker and its designated town authority do not and will not assume liability for drainage facilities designed by others.

Krysta Houtchens, PE

---

Colorado P.E. License No. 49550

---

Seal and Date

**Introduction**

This Drainage Conformance Letter has been prepared for the Kum & Go Gas and Convenience Store #2293 located at Lot 1 of Tails at Crowfoot Filing No. 9, 1<sup>st</sup> A. The purposed of this letter is to show that the proposed development conforms to the Storm Drainage and Environmental Criteria Manual for the Town of Parker, and the *Trails at Crowfoot Final Drainage Report*, prepared by CVL Consultants, dated June 2018, herein referred to as “Master Drainage Report.”

**Location**

The project site is located at the southeast corner of Bayou Gulch Road and N. Pinery Parkway, which lies within the northeast ¼ of Section 9, Township 7 South, Range 66 West of the 6<sup>th</sup> Principal Meridian, Town of Parker, County of Douglas, State of Colorado. Lot 1 is bounded by N. Pinery Parkway to the north, Bayou Gulch to the west, Alpine Phlox to the east and vacant commercial property to the south. Refer to the Vicinity Map below for reference.



**VICINITY MAP**

**Proposed Development**

The proposed development includes a 3,968 sf Kum & Go Convenience Store with 8 MPD fueling canopy as well as associated drives, parking, sidewalk, landscaping and utilities. Detention for this proposed development is provided in the public Regional Detention Pond D, as referenced

in the approved “Trails at Crowfoot Final Drainage Report” by CVL Consultants dated June 2018, hereafter referred to as the “Master Drainage Report”.

The proposed Kum & Go is located within an existing 4.155-acre tract of commercially zoned vacant parcel. As part of this development the 4.155-acre tract will be subdivided into three lots (Lot 1, Lot 2 and Lot 3). The Kum & Go is proposed on Lot 1, which a proposed 1.43-acre parcel at the northwest corner of the existing Tract E. Proposed shared access drives are proposed as part of this development that are located partially on Lot 2 (0.66-acres) and Lot 3 (2.06-acres).

The proposed Lots 1, 2 and 3 lies within Basins F1, F10 & F11 of the “Master Drainage Report”. Per the “Master Drainage Report” the existing pond and surrounding storm infrastructure has been designed based on the below commercial values which results in an allowed imperviousness for the development of greater than 90%.

| Basin | Area       | Imperviousness | Q2       | Q100      |
|-------|------------|----------------|----------|-----------|
| F1    | 1.71 acres | 90.64%         | 4.59-cfs | 13.55-cfs |
| F10   | 1.93 acres | 92.20%         | 5.30-cfs | 15.64-cfs |
| F11   | 1.50 acres | 91.79%         | 4.07-cfs | 12.03-cfs |

In the developed condition, the proposed development has a combined impervious value of 83.55% including all site improvements, assumed 90% impervious for future commercial development on Lots 2 and 3 and shared private drives as well as portions of the Right-of-way as outlined in the “Master Drainage Report”. The proposed development improvements result is an impervious value (83.55%) significantly lower than the allowed impervious (90%), therefore there are no required improvements to the existing storm sewer infrastructure or regional facility. The future development of Lot 2 & 3 will be required to analyze overall imperviousness and confirm future development maintains the maximum allowed imperviousness. Proposed and existing storm sewer has been designed for the future developed condition of Lots 2 & 3.

The proposed development anticipates to utilize sheet runoff for a portion of the development as well as tie into the existing storm inlet located at the southwest corner of the intersection of Alpine Phlox & Pinery following historic drainage patterns as outlined in the “Master Drainage Report”.

Refer to the Appendix for basin maps and calculations.

### **Historic Drainage**

The site is currently an undeveloped lot and consists of natural grasses and shrubs, with concrete sidewalks along the north and east perimeter of the site. The site naturally drains to the north & west and into the existing Alpine Phlox right-of-way on the east side of the property. Runoff is then captured by a series of existing inlets within the Alpine Phlox ROW. The existing inlets captures within Alpine Phlox will capture the 5-year and 100-year runoff and convey it to the

Regional Detention Pond D. Refer to the Master Drainage Report Plan in the appendix for more information.

Per the NRCS Soil Survey, the subsurface characteristics consist approximately 75% of Fondis Kutch associate soil which is defined as hydrologic soil group C and 25% of Renohill Sandy Loam, reddish variant which is classified as hydrologic soil group D. The soils have slow and very slow infiltration rates as defined for hydrological soil groups C & D. For the calculations within this report, hydrologic soil group C was used for runoff coefficients. Refer to the Appendix for the NRCS Soil Survey Map.

There are no recently reported cases of flooding within or around the development. The site is located within Zone "X", areas determined to be outside 0.2% annual chance floodplain, of the Flood Plain, as designated on the Flood Insurance Rate Map (FIRM) 08035C0183G, map last revised 03/16/2016. Refer to the Appendix for the FIRMette.

### **Existing Storm Water Basins & Drainage Patterns**

Drainage patterns in the existing condition of the project site generally drain to the north & east and consist of Basins F1, F10 & F11 of the "Master Drainage Report". Flows from Basins F1, F10 and F11 are directed to the Alpine Phlox right-of-way where a series of existing inlets will capture the runoff and convey it to existing Pond D. The proposed condition is in compliance with the "Master Drainage Report" as outlined in the section above and will not have any negative impacts on the downstream system. Refer to the Appendix for excerpts of the "Master Drainage Report" and the Master Drainage Plan.

### **Developed Storm Water Conditions**

The site in the proposed condition consists of ten total basins (P-1, P-2, P-3, P-4, P-5, P-6, P-7, P-8, P-9, P-10) which direct flows to on-site inlets as well as off-site where they are capture within existing storm sewer infrastructure. The following is a description of the proposed drainage basins.

**Basin P-1:** Basin P-1 is 0.11 acres near the northwest corner of the site and consists of hardscape sidewalk as well as landscape for an impervious value of 13.6%. The 5-year and 100-year C values were determined to be 0.14 and 0.54, respectively; and anticipated 5-year runoff flows of 0.08 CFS and 100-year runoff flows of 0.53 CFS. Flows from Basin P-1 are directed towards an ADS 8" slotted drain in the landscaping that will fully capture the 100-year runoff. Captured runoff will conveyed from the slotted drain via proposed 8" PVC & 18" RCP storm infrastructure to an existing inlet located east of the project site within the Alpine Phlox ROW that will ultimately convey the runoff to the existing detention Pond D per the "Master Drainage Report".

**Basin P-2:** Basin P-2 is 0.09 acres and consists entirely of the Kum & Go Convenience Store roof for an impervious value of 90.0%. The 5-year and 100-year C values were determined to be 0.76 and 0.85, respectively; and anticipated 5-year runoff flows of 0.34 CFS and 100-year runoff flows

of 0.70 CFS. Flows from Basin P-2 are captured by roof drains and conveyed via proposed 8" PVC & 18" RCP storm infrastructure to an existing inlet located east of the project site within the Alpine Phlox ROW that will ultimately convey the runoff to the existing detention Pond D per the "Master Drainage Report".

**Basin P-3:** Basin P-3 is 0.14 acres and consists entirely of the Kum & Go fueling canopy roof for an impervious value of 90.0%. The 5-year and 100-year C values were determined to be 0.76 and 0.85, respectively; and anticipated 5-year runoff flows of 0.49 CFS and 100-year runoff flows of 1.03 CFS. Flows from Basin P-3 are captured by roof drains and conveyed via proposed 8" PVC & 18" RCP storm infrastructure towards STM MH-1 and ultimately to an existing inlet located east of the project site within the Alpine Phlox ROW that will ultimately convey the runoff to the existing detention Pond D per the "Master Drainage Report".

**Basin P-4:** Basin P-4 is 0.08 acres near the northwest corner of the site and consists of hardscape sidewalk, parking and drives for an impervious value of 91.0%. The 5-year and 100-year C values were determined to be 0.78 and 0.85, respectively; and anticipated 5-year runoff flows of 0.28 CFS and 100-year runoff flows of 0.57 CFS. Flows from Basin P-4 sheet flow across the parking and drives to proposed curb and gutter that conveys the runoff to a proposed Type 13 combination inlet (Inlet 1) at Design Point 3. Inlet 1 will capture 0.2 cfs and 0.4 cfs in the 5-year and 100-year storm events respectively and the remaining runoff will bypass and flow into the N. Pinery Parkway ROW. Captured runoff will be conveyed from the inlet via proposed 18" RCP storm infrastructure towards Inlet 2 and then to an existing inlet located east of the project site within the Alpine Phlox ROW that will ultimately convey the runoff to the existing detention Pond D per the "Master Drainage Report". Bypass runoff will be conveyed via existing curb and gutter within the ROW to the existing inlet located east of the project site within the Alpine Phlox ROW that will ultimately convey the runoff to the existing detention Pond D per the "Master Drainage Report".

**Basin P-5:** Basin P-5 is 0.50 acres near the southwest portion of the site and consists of hardscape sidewalk, parking and drives as well as landscaping for an impervious value of 68.0%. The 5-year and 100-year C values were determined to be 0.59 and 0.76, respectively; and anticipated 5-year runoff flows of 1.34 CFS and 100-year runoff flows of 3.21 CFS. Flows from Basin P-5 sheet flow across the parking and drives to proposed curb and gutter that conveys the runoff to a proposed 5' Type R inlet (Inlet 2) at Design Point 4. Inlet 2 will fully capture the 5-year and 100-year storm events. Captured runoff will be conveyed from the inlet via proposed 18" RCP storm infrastructure to an existing inlet located east of the project site within the Alpine Phlox ROW that will ultimately convey the runoff to the existing detention Pond D per the "Master Drainage Report".

**Basin P-6:** Basin P-6 is 0.15 acres near the northeast portion of the site and consists of hardscape sidewalk, parking and drives for an impervious value of 100%. The 5-year and 100-year C values were determined to be 0.85 and 0.89, respectively; and anticipated 5-year runoff flows of 0.60 CFS and 100-year runoff flows of 1.18 CFS. Flows from Basin P-6 sheet flow across the parking and drives to proposed curb and gutter that conveys the runoff to a proposed 5' Type R inlet

(Inlet 2) at Design Point 4. Inlet 2 will capture fully capture the 5-year and 100-year storm events. Captured runoff will be conveyed from the inlet via proposed 18" RCP storm infrastructure to an existing inlet located east of the project site within the Alpine Phlox ROW that will ultimately convey the runoff to the existing detention Pond D per the "Master Drainage Report".

**Basin P-7:** Basins P-7 is 0.50 acres located south & east of the proposed Kum & Go site and consists primarily of vacant commercial land and a portion of the Alpine Phlox ROW with an assumed future developed impervious value of 90.0%. The 5-year and 100-year C values were determined to be 0.76 and 0.85, respectively; and anticipated 5-year runoff flows of 1.73 CFS and 100-year runoff flows of 3.63 CFS. Runoff from Basin P-7 sheet flow off-site to the east where it is collected in existing storm infrastructure within the Alpine Phlox ROW. At the time of development, the 5-year runoff from Basin P-7 should be captured onsite and piped via proposed storm sewer to the existing inlet at Design Point 6. Captured runoff will be conveyed via existing storm infrastructure to the existing detention Pond D per the "Master Drainage Report".

**Basin P-8:** Basins P-8 is 0.91 acres located south of the proposed Kum & Go site and consists vacant commercial land, shared access drive, landscape, sidewalk and a portion of the Bayou Gulch and Alpine Phlox ROWs with an assumed future developed impervious value of 90.0%. The 5-year and 100-year C values were determined to be 0.76 and 0.85, respectively; and anticipated 5-year runoff flows of 7.51 CFS and 100-year runoff flows of 15.72 CFS. Runoff from Basin P-8 sheet flow off-site to the north and east where it is conveyed in proposed curb and gutter existing storm infrastructure within the Alpine Phlox ROW at Design Point 7. At the time of development, the 5-year runoff from Basin P-8 should be captured onsite and piped via proposed storm sewer to the existing inlet at Design Point 6. Captured runoff will be conveyed via existing storm infrastructure to the existing detention Pond D per the "Master Drainage Report".

**Basin P-9:** Basins P-9 is 0.69 acres located east of the proposed Kum & Go site and consists primarily of vacant commercial land with an assumed future developed impervious value of 90.0%. The 5-year and 100-year C values for the future developed site were determined to be 0.76 and 0.85, respectively; and anticipated 5-year runoff flows of 2.46 CFS and 100-year runoff flows of 5.14 CFS. Runoff from Basin P-9 in the interim undeveloped condition sheet flows off-site to the east where it is collected in existing storm infrastructure within the Alpine Phlox ROW. The proposed development includes an 18" RCP storm sewer along the northern boundary of Basin P-9. At the time of development, the 5-year runoff from Basin P-9 should be captured onsite and piped via proposed storm sewer to the existing inlet at Design Point 8. Captured runoff will be conveyed via existing storm infrastructure to the existing detention Pond D per the "Master Drainage Report".

**Basin P-10:** Basins P-11 is 0.88 acres located north of the proposed Kum & Go site and consists vacant commercial land, landscape, sidewalk and a portion of the N. Pinery Parkway and Alpine Phlox ROWs for an impervious value of 70.9%. The 5-year and 100-year C values were determined to be 0.61 and 0.77, respectively; and anticipated 5-year runoff flows of 2.41 CFS and 100-year runoff flows of 5.68 CFS. Runoff from Basin P-10 sheet flow off-site to the north and east where it discharges offsite and is collected in existing curb and gutter that conveys the runoff to an

existing storm inlet at Design Point 8, located east of the project site within the Alpine Phlox ROW that will ultimately convey the runoff to the existing detention Pond D per the “Master Drainage Report”.

Refer to the Appendix for excerpts of the “Master Drainage Report” and the Proposed Drainage Plan.

**Conclusions & Recommendations**

In the proposed condition the site drainage is in conformance and follows the historic drainage patterns as outlined in the “Master Drainage Report”. The proposed improvements within three proposed lots making up the existing Tract E result in an impervious value of 83.11%, which is significantly less than the approximately 90% allowed impervious values as outlined in the “Master Drainage Report”. Therefore, the proposed development has addressed will not adversely affect the downstream storm infrastructure and will require no changes or additions to the existing storm sewer infrastructure and water quality and detention facility. It is requested that the City accept this letter of drainage compliance.

**APPENDIX**

- APPENDIX A
  - FEMA Firmette
  - NRCS Soil Survey
- APPENDIX B
  - Hydrology Calculations
- APPENDIX C
  - Hydraulic Calculations
- APPENDIX D
  - Master Drainage Report
    - Excerpts
    - Existing Drainage Map
- APPENDIX E
  - Developed Drainage Map

**APPENDIX A**  
**FIRM, Soil Survey**

# National Flood Hazard Layer FIRMette























104°47'17"W 39°27'50"N



## Legend

SEE FIS REPORT FOR DETAILED LEGEND AND INDEX MAP FOR FIRM PANEL LAYOUT

- |                                    |   |  |
|------------------------------------|---|--|
| <b>SPECIAL FLOOD HAZARD AREAS</b>  |    | Without Base Flood Elevation (BFE)<br><i>Zone A, V, A99</i>  |
|                                    |    | With BFE or Depth <i>Zone AE, AO, AH, VE, AR</i><br>Regulatory Floodway  |
| <b>OTHER AREAS OF FLOOD HAZARD</b> |    | 0.2% Annual Chance Flood Hazard, Areas of 1% annual chance flood with average depth less than one foot or with drainage areas of less than one square mile <i>Zone X</i> |
|                                    |    | Future Conditions 1% Annual Chance Flood Hazard <i>Zone X</i>  |
|                                    |    | Area with Reduced Flood Risk due to Levee. See Notes. <i>Zone X</i>  |
|                                    |    | Area with Flood Risk due to Levee <i>Zone D</i>  |
| <b>OTHER AREAS</b>                 |    | NO SCREEN Area of Minimal Flood Hazard <i>Zone X</i>   |
|                                    |    | Effective LOMRs  |
| <b>GENERAL STRUCTURES</b>          |    | Channel, Culvert, or Storm Sewer   |
|                                    |    | Levee, Dike, or Floodwall  |
| <b>OTHER FEATURES</b>              |    | 20.2 Cross Sections with 1% Annual Chance Water Surface Elevation  |
|                                    |    | 17.5 Coastal Transect  |
|                                    |   | Base Flood Elevation Line (BFE)  |
|                                    |  | Limit of Study   |
|                                    |  | Jurisdiction Boundary  |
|                                    |  | Coastal Transect Baseline  |
| <b>MAP PANELS</b>                  |   | Digital Data Available   |
|                                    |  | No Digital Data Available  |
|                                    |  | Unmapped   |
-  The pin displayed on the map is an approximate point selected by the user and does not represent an authoritative property location.



This map complies with FEMA's standards for the use of digital flood maps if it is not void as described below. The basemap shown complies with FEMA's basemap accuracy standards

The flood hazard information is derived directly from the authoritative NFHL web services provided by FEMA. This map was exported on **9/13/2022 at 6:37 PM** and does not reflect changes or amendments subsequent to this date and time. The NFHL and effective information may change or become superseded by new data over time.

This map image is void if the one or more of the following map elements do not appear: basemap imagery, flood zone labels, legend, scale bar, map creation date, community identifiers, FIRM panel number, and FIRM effective date. Map images for unmapped and unmodernized areas cannot be used for regulatory purposes.

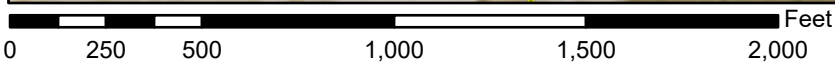

1:6,000

104°46'39"W 39°27'23"N

Hydrologic Soil Group—Castle Rock Area, Colorado



Soil Map may not be valid at this scale.

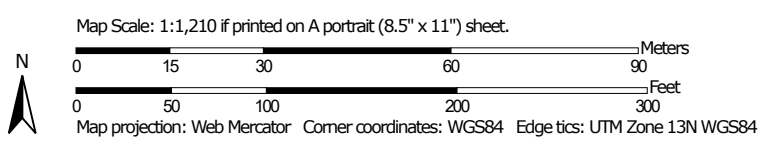

## MAP LEGEND

### Area of Interest (AOI)









 Area of Interest (AOI)

### Soils

#### Soil Rating Polygons





 A  
 A/D  
 B  
 B/D  
 C  
 C/D  
 D  
 Not rated or not available

#### Soil Rating Lines

 A  
 A/D  
 B  
 B/D  
 C  
 C/D  
 D  
 Not rated or not available

#### Soil Rating Points





 A  
 A/D  
 B  
 B/D

 C  
 C/D  
 D  
 Not rated or not available

### Water Features

 Streams and Canals

### Transportation

 Rails  
 Interstate Highways  
 US Routes  
 Major Roads  
 Local Roads

### Background

 Aerial Photography

## MAP INFORMATION

The soil surveys that comprise your AOI were mapped at 1:20,000.

**Warning:** Soil Map may not be valid at this scale.

Enlargement of maps beyond the scale of mapping can cause misunderstanding of the detail of mapping and accuracy of soil line placement. The maps do not show the small areas of contrasting soils that could have been shown at a more detailed scale.

Please rely on the bar scale on each map sheet for map measurements.

Source of Map: Natural Resources Conservation Service  
 Web Soil Survey URL:  
 Coordinate System: Web Mercator (EPSG:3857)

Maps from the Web Soil Survey are based on the Web Mercator projection, which preserves direction and shape but distorts distance and area. A projection that preserves area, such as the Albers equal-area conic projection, should be used if more accurate calculations of distance or area are required.

This product is generated from the USDA-NRCS certified data as of the version date(s) listed below.

Soil Survey Area: Castle Rock Area, Colorado  
 Survey Area Data: Version 14, Aug 31, 2021

Soil map units are labeled (as space allows) for map scales 1:50,000 or larger.

Date(s) aerial images were photographed: Jun 9, 2021—Jun 12, 2021

The orthophoto or other base map on which the soil lines were compiled and digitized probably differs from the background imagery displayed on these maps. As a result, some minor shifting of map unit boundaries may be evident.

## Hydrologic Soil Group

| Map unit symbol                    | Map unit name  | Rating | Acres in AOI | Percent of AOI |
|------------------------------------|--|--------|--------------|----------------|
| Fu                                 | Fondis-Kutch association                                     | C      | 5.7          | 74.9%          |
| RoE                                | Renohill sandy loam, reddish variant, 5 to 20 percent slopes | D      | 1.9          | 25.1%          |
| <b>Totals for Area of Interest</b> |  |        | <b>7.5</b>   | <b>100.0%</b>  |

### Description

Hydrologic soil groups are based on estimates of runoff potential. Soils are assigned to one of four groups according to the rate of water infiltration when the soils are not protected by vegetation, are thoroughly wet, and receive precipitation from long-duration storms.

The soils in the United States are assigned to four groups (A, B, C, and D) and three dual classes (A/D, B/D, and C/D). The groups are defined as follows:

Group A. Soils having a high infiltration rate (low runoff potential) when thoroughly wet. These consist mainly of deep, well drained to excessively drained sands or gravelly sands. These soils have a high rate of water transmission.

Group B. Soils having a moderate infiltration rate when thoroughly wet. These consist chiefly of moderately deep or deep, moderately well drained or well drained soils that have moderately fine texture to moderately coarse texture. These soils have a moderate rate of water transmission.

Group C. Soils having a slow infiltration rate when thoroughly wet. These consist chiefly of soils having a layer that impedes the downward movement of water or soils of moderately fine texture or fine texture. These soils have a slow rate of water transmission.

Group D. Soils having a very slow infiltration rate (high runoff potential) when thoroughly wet. These consist chiefly of clays that have a high shrink-swell potential, soils that have a high water table, soils that have a claypan or clay layer at or near the surface, and soils that are shallow over nearly impervious material. These soils have a very slow rate of water transmission.

If a soil is assigned to a dual hydrologic group (A/D, B/D, or C/D), the first letter is for drained areas and the second is for undrained areas. Only the soils that in their natural condition are in group D are assigned to dual classes.

## Rating Options

*Aggregation Method:* Dominant Condition

*Component Percent Cutoff:* None Specified

*Tie-break Rule:* Higher

**APPENDIX B**  
**Hydrology Calculations**

**DEVELOPED CONDITION**

**Runoff Coefficients**

Project: Kum & Go 2293 - SEC Bayou Gulch & N. Pinery Parkway - Parker, CO  
 Section:

Created by: KMH Date: 6/23/2023  
 Checked by: KMH Date: 6/23/2023

| Sub-Basin Data   |  |      | Composite C    |                |                 |                  |       | Sub Area (Roof)                          |                |                 |                  |     | Sub Area (Drives/Walks) |                |                |                 |                  | Sub Area (Landscape) |      |                |                |                 |                  |     |      |  |  |
|------------------|--|------|----------------|----------------|-----------------|------------------|-------|--|----------------|-----------------|------------------|-----|-------------------------|----------------|----------------|-----------------|------------------|----------------------|------|----------------|----------------|-----------------|------------------|-----|------|--|--|
| Basin ID         | Description                            | Area | C <sub>2</sub> | C <sub>5</sub> | C <sub>10</sub> | C <sub>100</sub> | (%)   | C <sub>2</sub>                           | C <sub>5</sub> | C <sub>10</sub> | C <sub>100</sub> | (%) | (ac)                    | C <sub>2</sub> | C <sub>5</sub> | C <sub>10</sub> | C <sub>100</sub> | (%)                  | (ac) | C <sub>2</sub> | C <sub>5</sub> | C <sub>10</sub> | C <sub>100</sub> | (%) | (ac) |  |  |
| Developed Onsite |  |      |                |                |                 |                  |       |  |                |                 |                  |     |                         |                |                |                 |                  |                      |      |                |                |                 |                  |     |      |  |  |
| P-1              | Landscaping & Walks                    | 0.10 | 0.11           | 0.15           | 0.24            | 0.54             | 14.4  | 0.74                                     | 0.76           | 0.79            | 0.85             | 90  | 0.00                    | 0.83           | 0.85           | 0.87            | 0.89             | 100                  | 0.01 | 0.01           | 0.05           | 0.15            | 0.49             | 2   | 0.09 |  |  |
| P-2              | Building                               | 0.09 | 0.74           | 0.76           | 0.79            | 0.85             | 90.0  | 0.74                                     | 0.76           | 0.79            | 0.85             | 90  | 0.09                    | 0.83           | 0.85           | 0.87            | 0.89             | 100                  | 0.00 | 0.01           | 0.05           | 0.15            | 0.49             | 2   | 0.00 |  |  |
| P-3              | Canopy                                 | 0.14 | 0.74           | 0.76           | 0.79            | 0.85             | 90.0  | 0.74                                     | 0.76           | 0.79            | 0.85             | 90  | 0.14                    | 0.83           | 0.85           | 0.87            | 0.89             | 100                  | 0.00 | 0.01           | 0.05           | 0.15            | 0.49             | 2   | 0.00 |  |  |
| P-4              | Parking/Drives, Walks & Landscaping    | 0.08 | 0.75           | 0.78           | 0.80            | 0.85             | 91.0  | 0.74                                     | 0.76           | 0.79            | 0.85             | 90  | 0.00                    | 0.83           | 0.85           | 0.87            | 0.89             | 100                  | 0.07 | 0.01           | 0.05           | 0.15            | 0.49             | 2   | 0.01 |  |  |
| P-5              | Private Drive, Walks & Landscaping     | 0.49 | 0.56           | 0.59           | 0.63            | 0.76             | 68.0  | 0.74                                     | 0.76           | 0.79            | 0.85             | 90  | 0.00                    | 0.83           | 0.85           | 0.87            | 0.89             | 100                  | 0.33 | 0.01           | 0.05           | 0.15            | 0.49             | 2   | 0.16 |  |  |
| P-6              | Private Drive, Walks & Landscaping     | 0.15 | 0.83           | 0.85           | 0.87            | 0.89             | 100.0 | 0.74                                     | 0.76           | 0.79            | 0.85             | 90  | 0.00                    | 0.83           | 0.85           | 0.87            | 0.89             | 100                  | 0.15 | 0.01           | 0.05           | 0.15            | 0.49             | 2   | 0.00 |  |  |
| P-7              | Vacant commercial property             | 0.50 | 0.74           | 0.76           | 0.79            | 0.85             | 90.0  | ASSUME 90% IMPERVIOUS (PER MASTER STUDY) |                |                 |                  |     |                         |                |                |                 |                  |                      |      |                |                |                 |                  |     |      |  |  |
| P-8              | Vacant commercial property             | 2.22 | 0.74           | 0.76           | 0.79            | 0.85             | 90.0  | ASSUME 90% IMPERVIOUS (PER MASTER STUDY) |                |                 |                  |     |                         |                |                |                 |                  |                      |      |                |                |                 |                  |     |      |  |  |
| P-9              | Vacant commercial property             | 0.69 | 0.74           | 0.76           | 0.79            | 0.85             | 90.0  | ASSUME 90% IMPERVIOUS (PER MASTER STUDY) |                |                 |                  |     |                         |                |                |                 |                  |                      |      |                |                |                 |                  |     |      |  |  |
| P-10             | Private Drive,ROW, Walks & Landscaping | 1.49 | 0.72           | 0.74           | 0.77            | 0.84             | 86.9  | 0.74                                     | 0.76           | 0.79            | 0.85             | 90  | 0.00                    | 0.83           | 0.85           | 0.87            | 0.89             | 100                  | 1.29 | 0.01           | 0.05           | 0.15            | 0.49             | 2   | 0.20 |  |  |
| Composite        | Developed Site Composite               | 5.95 | 0.71           | 0.73           | 0.77            | 0.83             | 86.34 |  |                |                 |                  |     | 0.23                    |                |                |                 |                  |                      | 1.85 |                |                |                 |                  |     | 0.46 |  |  |

**DEVELOPED CONDITIONS**

**Time of Concentration**

Project: Kum & Go 2293 - SEC Bayou Gulch & N. Pinery Parkway - Parker, CO  
 Section: \_\_\_\_\_

Created by: KMH Date: 6/23/2023  
 Checked by: KMH Date: 6/23/2023

Urban TOC<sub>min</sub> = 5 min  
 Rural TOC<sub>min</sub> = 10 min

| Basin ID | SUB-BASIN DATA                         |                |           | INITIAL/OVERLAND FLOW (t <sub>o</sub> ) |               |                      | TRAVEL TIME (t <sub>t</sub> ) |                        |      |                                      |                               |                 | Tc CHECK (Urbanized basins) |  |           |             | FINAL Tc (min) |                          |                                    |
|----------|--|----------------|-----------|---|---------------|----------------------|-------------------------------|------------------------|------|--------------------------------------|-------------------------------|-----------------|-----------------------------|--|-----------|-------------|----------------|--------------------------|------------------------------------|
|          | Description                            | C <sub>s</sub> | Area (ac) | Length (ft)                             | Slope (ft/ft) | t <sub>o</sub> (min) | Length (ft)                   | S <sub>w</sub> (ft/ft) | Code | Description                          | Convey Coef (C <sub>c</sub> ) | Velocity (ft/s) | Time (min)                  | t <sub>c</sub> = t <sub>i</sub> + t <sub>t</sub> (min) | (Yes /No) | Length (ft) |                | T <sub>c</sub> max (min) | Tc <sub>max</sub> > t <sub>c</sub> |
| P-1      | Landscaping & Walks                    | 0.15           | 0.10      | 28                                      | 0.25          | 3.13                 | 10                            | 0.01                   | 5    | Grassed waterway                     | 15.00                         | 1.50            | 0.11                        | 3.24   | YES       | 38.00       | 10.21          | Regional Tc              | 5.00                               |
| P-2      | Building                               | 0.76           | 0.09      | 45                                      | 0.02          | 3.39                 | 0                             | 0.01                   | 6    | Paved areas and shallow paved swales | 20.00                         | 1.79            | 0.00                        | 3.39   | YES       | 45.00       | 10.25          | Regional Tc              | 5.00                               |
| P-3      | Canopy                                 | 0.76           | 0.14      | 50                                      | 0.02          | 3.80                 | 0                             | 0.01                   | 6    | Paved areas and shallow paved swales | 20.00                         | 1.41            | 0.00                        | 3.80   | YES       | 50.00       | 10.28          | Regional Tc              | 5.00                               |
| P-4      | Parking/Drives, Walks & Landscaping    | 0.78           | 0.08      | 42                                      | 0.04          | 2.39                 | 89                            | 0.04                   | 6    | Paved areas and shallow paved swales | 20.00                         | 4.00            | 0.37                        | 2.76   | YES       | 131.00      | 10.73          | Regional Tc              | 5.00                               |
| P-5      | Private Drive, Walks & Landscaping     | 0.59           | 0.49      | 143                                     | 0.10          | 5.16                 | 87                            | 0.01                   | 6    | Paved areas and shallow paved swales | 20.00                         | 2.00            | 0.73                        | 5.89   | YES       | 230.00      | 11.28          | Regional Tc              | 5.89                               |
| P-6      | Private Drive, Walks & Landscaping     | 0.85           | 0.15      | 47                                      | 0.02          | 2.46                 | 133                           | 0.02                   | 6    | Paved areas and shallow paved swales | 20.00                         | 2.83            | 0.78                        | 3.25   | YES       | 180.00      | 11.00          | Regional Tc              | 5.00                               |
| P-7      | Vacant commercial property             | 0.76           | 0.50      | 100                                     | 0.02          | 4.88                 | 100                           | 0.02                   | 6    | Paved areas and shallow paved swales | 20.00                         | 2.83            | 0.59                        | 5.47   | YES       | 200.00      | 11.11          | Regional Tc              | 5.47                               |
| P-8      | Vacant commercial property             | 0.76           | 2.22      | 80                                      | 0.05          | 3.23                 | 470                           | 0.03                   | 6    | Paved areas and shallow paved swales | 20.00                         | 3.46            | 2.26                        | 5.49   | YES       | 550.00      | 13.06          | Regional Tc              | 5.49                               |
| P-9      | Vacant commercial property             | 0.76           | 0.69      | 80                                      | 0.03          | 3.82                 | 100                           | 0.02                   | 6    | Paved areas and shallow paved swales | 20.00                         | 2.83            | 0.59                        | 4.41   | YES       | 180.00      | 11.00          | Regional Tc              | 5.00                               |
| P-10     | Private Drive,ROW, Walks & Landscaping | 0.74           | 1.49      | 50                                      | 0.03          | 3.37                 | 356                           | 0.04                   | 6    | Paved areas and shallow paved swales | 20.00                         | 4.00            | 1.48                        | 4.85   | YES       | 406.00      | 12.26          | Regional Tc              | 5.00                               |

Notes:

t<sub>i</sub> = (0.395\*(1.1-C<sub>s</sub>)\*(L^0.5))/(S^0.33), from UDFCD Eqn 6-3  
 Velocity from V = C<sub>v</sub>\*S<sub>w</sub>^0.5, from UDFCD Eqn 6-4, C<sub>v</sub> from Table 6-2(See Sheet Design Info)  
 t<sub>i</sub> = L/60V  
 t<sub>i</sub> max = 10+L/180  
 Final Tc > 10 min for nonurban watersheds

| Code | Type of Land Surface                 | Conveyance Factor, K |
|------|--------------------------------------|----------------------|
| 1    | Heavy meadow                         | 2.5                  |
| 2    | Tillage/field                        | 5                    |
| 3    | Short pasture and lawns              | 7                    |
| 4    | Nearly bare ground                   | 10                   |
| 5    | Grassed waterway                     | 15                   |
| 6    | Paved areas and shallow paved swales | 20                   |

**DEVELOPED CONDITIONS**

**Storm Drainage System Design (Rational Method Procedure)**

Project: Kum & Go 2293 - SEC Bayou Gulch & N. Pinery Parkway - Parker, CO  
 Section: \_\_\_\_\_

Created by: KMH      06/23/2023  
 Checked by: KMH      6/23/2023

**5 YEAR MINOR STORM**

Design Storm: 5-yr      P = 1.39 in

| LOCATION | DESIGN POINT | DIRECT RUNOFF                           |           |                     |                      |           |             |         | TOTAL RUNOFF         |                 |             |         | STREET    |                   | PIPE              |           |                | TRAVEL TIME |                |                      | REMARKS |                   |
|----------|--------------|---|-----------|---------------------|----------------------|-----------|-------------|---------|----------------------|-----------------|-------------|---------|-----------|-------------------|-------------------|-----------|----------------|-------------|----------------|----------------------|---------|-------------------|
|          |              | AREA DESIGN (name)                      | AREA (AC) | RUNOFF COEFF (5 Yr) | t <sub>c</sub> (MIN) | C.A. (AC) | I (IN / HR) | Q (CFS) | t <sub>c</sub> (MIN) | SUM (C* A) (AC) | I (IN / HR) | Q (CFS) | SLOPE (%) | STREET FLOW (CFS) | DESIGN FLOW (CFS) | SLOPE (%) | PIPE SIZE (in) | LENGTH (FT) | VELOCITY (FPS) | t <sub>c</sub> (MIN) |         |                   |
| DP       | (1)          | (2)                                     | (3)       | (4)                 | (5)                  | (6)       | (7)         | (8)     | (9)                  | (10)            | (11)        | (12)    | (13)      | (14)              | (15)              | (16)      | (17)           | (18)        | (19)           | (20)                 | (21)    | (22)              |
|          | Developed    |   |           |                     |                      |           |             |         |                      |                 |             |         |           |                   |                   |           |                |             |                |                      |         |                   |
|          | P-1          | Landscaping & Walks                     | P-1       | 0.11                | 0.14                 | 5.00      | 0.02        | 4.71    | 0.08                 |                 |             |         |           |                   |                   |           |                |             |                |                      |         | ADS SLOTTED DRAIN |
|          | P-2          | Building                                | P-2       | 0.09                | 0.76                 | 5.00      | 0.07        | 4.71    | 0.34                 |                 |             |         |           |                   |                   |           |                |             |                |                      |         | ROOF DRAIN        |
| 1        | P-1 & P-2    |   |           | 0.21                |                      |           |             |         |                      | 5.00            | 0.09        | 4.71    | 0.41      |                   |                   | 0.41      | 2.30           | 8           | 255.00         | 2.71                 | 1.57    |                   |
|          | P-3          | Canopy                                  | P-3       | 0.14                | 0.76                 | 5.00      | 0.10        | 4.71    | 0.49                 |                 |             |         |           |                   |                   | 0.49      | 2.00           | 8           | 123.00         | 5.02                 | 0.41    | ROOF DRAIN        |
| 2        | DP1 & P-3    |   |           | 0.34                |                      |           |             |         |                      | 6.57            | 0.19        | 4.36    | 0.84      |                   |                   | 0.84      | 2.50           | 12          | 30.00          | 6.17                 | 0.08    | STM MH-1          |
|          | P-4          | Parking/Drives, Walks & Landscaping     | P-4       | 0.08                | 0.78                 | 5.00      | 0.06        | 4.71    | 0.28                 |                 |             |         |           |                   |                   |           |                |             |                |                      |         | STM INLET 1       |
| 3        | DP2 & P-4    |   |           | 0.42                |                      |           |             |         |                      | 6.65            | 0.25        | 4.34    | 1.09      |                   |                   | 1.09      | 2.50           | 18          | 47.00          | 5.37                 | 0.15    |                   |
|          | P-5          | Private Drive, Walks & Landscaping      | P-5       | 0.50                | 0.59                 | 5.83      | 0.30        | 4.52    | 1.34                 |                 |             |         |           |                   |                   |           |                |             |                |                      |         |                   |
|          | P-6          | Private Drive, Walks & Landscaping      | P-6       | 0.15                | 0.85                 | 5.00      | 0.13        | 4.71    | 0.60                 |                 |             |         |           |                   |                   |           |                |             |                |                      |         |                   |
| 4        | P-5 & P-6    |   |           | 0.65                |                      |           |             |         |                      | 5.83            | 0.42        | 4.52    | 1.92      |                   |                   |           |                |             |                |                      |         | STM INLET 2       |
| 5        | DP3 & DP4    | Combined flow at Inlet 2                |           | 1.07                |                      |           |             |         |                      | 6.80            | 0.68        | 4.31    | 2.91      |                   |                   | 2.91      | 5.00           | 18          | 139.00         | 8.89                 | 0.26    |                   |
| 6        | P-7          | Vacant commercial property              | P-7       | 0.50                | 0.76                 | 5.47      | 0.38        | 4.60    | 1.73                 |                 |             |         |           |                   |                   | 1.73      | 2.50           | 18          | 134.90         | 8.89                 | 0.25    | EX INLET SDIN-102 |
| 7        | P-8          | Vacant commercial property              | P-8       | 2.21                | 0.76                 | 6.02      | 1.68        | 4.48    | 7.51                 |                 |             |         |           |                   |                   | 7.51      | 3.60           | 24          | 175.80         | 12.02                | 0.24    | EX INLET SDIN-101 |
|          | P-9          | Vacant commercial property              | P-9       | 0.69                | 0.76                 | 5.00      | 0.52        | 4.71    | 2.46                 |                 |             |         |           |                   |                   |           |                |             |                |                      |         |                   |
|          | P-10         | Private Drive, ROW, Walks & Landscaping | P-10      | 0.88                | 0.61                 | 6.08      | 0.54        | 4.46    | 2.41                 |                 |             |         |           |                   |                   |           |                |             |                |                      |         |                   |
| 8        | P-9 & P-10   |   |           | 1.57                |                      |           |             |         |                      | 6.08            | 1.06        | 4.46    | 4.74      |                   |                   |           |                |             |                |                      |         | EX INLET SDIN-52  |

**DEVELOPED CONDITIONS**

**Storm Drainage System Design (Rational Method Procedure)**

Project: Kum & Go 2293 - SEC Bayou Gulch & N. Pinery Parkway - Parker, CO  
 Section: \_\_\_\_\_

Created by: KMH 06/23/2023  
 Checked by: KMH 6/23/2023

**100 YEAR MAJOR STORM**

Design Storm: 100-yr P = 2.60 in

| LOCATION  | DESIGN POINT | DIRECT RUNOFF                          |           |                       |                      |           |             |         | TOTAL RUNOFF         |                         |             |         | STREET    |                   | PIPE              |           |                | TRAVEL TIME |                | REMARKS |                      |                   |
|-----------|--------------|--|-----------|-----------------------|----------------------|-----------|-------------|---------|----------------------|-------------------------|-------------|---------|-----------|-------------------|-------------------|-----------|----------------|-------------|----------------|---------|----------------------|-------------------|
|           |              | AREA DESIGN (name)                     | AREA (AC) | RUNOFF COEFF (100 Yr) | t <sub>c</sub> (MIN) | C.A. (AC) | I (IN / HR) | Q (CFS) | t <sub>c</sub> (MIN) | SUM (C* <i>A</i> ) (AC) | I (IN / HR) | Q (CFS) | SLOPE (%) | STREET FLOW (CFS) | DESIGN FLOW (CFS) | SLOPE (%) | PIPE SIZE (in) | LENGTH (FT) | VELOCITY (FPS) |         | t <sub>c</sub> (MIN) |                   |
| DP        | (1)          | (2)                                    | (3)       | (4)                   | (5)                  | (6)       | (7)         | (8)     | (9)                  | (10)                    | (11)        | (12)    | (13)      | (14)              | (15)              | (16)      | (17)           | (18)        | (19)           | (20)    | (21)                 | (22)              |
| Developed |              |  |           |                       |                      |           |             |         |                      |                         |             |         |           |                   |                   |           |                |             |                |         |                      |                   |
|           | P-1          | Landscaping & Walks                    | P-1       | 0.11                  | 0.54                 | 5.00      | 0.06        | 8.82    | 0.53                 |                         |             |         |           |                   |                   |           |                |             |                |         |                      | ADS SLOTTED DRAIN |
|           | P-2          | Building                               | P-2       | 0.09                  | 0.85                 | 5.00      | 0.08        | 8.82    | 0.70                 |                         |             |         |           |                   |                   |           |                |             |                |         |                      | ROOF DRAIN        |
| 1         | P-1 & P-2    |  |           | 0.21                  |                      |           |             |         |                      | 5.00                    | 0.14        | 8.82    | 1.23      |                   |                   | 1.23      | 2.30           | 8           | 255.00         | 4.17    | 1.02                 |                   |
|           | P-3          | Canopy                                 | P-3       | 0.14                  | 0.85                 | 5.00      | 0.12        | 8.82    | 1.03                 |                         |             |         |           |                   |                   | 1.03      | 2.00           | 8           | 123.00         | 6.13    | 0.33                 | ROOF DRAIN        |
| 2         | DP1 & P-3    |  |           | 0.34                  |                      |           |             |         |                      | 6.02                    | 0.26        | 8.37    | 2.15      |                   |                   | 2.15      | 2.50           | 12          | 30.00          | 7.46    | 0.07                 | STM MH-1          |
|           | P-4          | Parking/Drives, Walks & Landscaping    | P-4       | 0.08                  | 0.85                 | 5.00      | 0.06        | 8.82    | 0.57                 |                         |             |         |           |                   |                   |           |                |             |                |         |                      | STM INLET 1       |
| 3         | DP2 & P-4    |  |           | 0.42                  |                      |           |             |         |                      | 6.09                    | 0.32        | 8.35    | 2.68      |                   |                   | 2.68      | 2.50           | 18          | 47.00          | 6.93    | 0.11                 |                   |
|           | P-5          | Private Drive, Walks & Landscaping     | P-5       | 0.50                  | 0.76                 | 5.83      | 0.38        | 8.45    | 3.21                 |                         |             |         |           |                   |                   |           |                |             |                |         |                      |                   |
|           | P-6          | Private Drive, Walks & Landscaping     | P-6       | 0.15                  | 0.89                 | 5.00      | 0.13        | 8.82    | 1.18                 |                         |             |         |           |                   |                   |           |                |             |                |         |                      |                   |
| 4         | P-5 & P-6    |  |           | 0.65                  |                      |           |             |         |                      | 5.83                    | 0.51        | 8.45    | 4.35      |                   |                   |           |                |             |                |         |                      | STM INLET 2       |
| 5         | DP3 & DP4    | Combined flow at Inlet 2               |           | 1.07                  |                      |           |             |         |                      | 6.20                    | 0.84        | 8.30    | 6.94      |                   |                   | 6.94      | 5.00           | 18          | 139.00         | 5.41    | 0.43                 |                   |
| 6         | P-7          | Vacant commercial property             | P-7       | 0.50                  | 0.85                 | 5.47      | 0.42        | 8.61    | 3.63                 |                         |             |         |           |                   |                   | 3.63      | 2.50           | 18          | 134.90         | 12.10   | 0.19                 | EX INLET SDIN-102 |
| 7         | P-8          | Vacant commercial property             | P-8       | 2.21                  | 0.85                 | 6.02      | 1.88        | 8.37    | 15.72                |                         |             |         |           |                   |                   | 15.72     | 3.60           | 24          | 175.80         | 11.77   | 0.25                 | EX INLET SDIN-101 |
|           | P-9          | Vacant commercial property             | P-9       | 0.69                  | 0.85                 | 5.00      | 0.58        | 8.82    | 5.14                 |                         |             |         |           |                   |                   |           |                |             |                |         |                      |                   |
|           | P-10         | Private Drive,ROW, Walks & Landscaping | P-10      | 0.88                  | 0.77                 | 6.08      | 0.68        | 8.35    | 5.68                 |                         |             |         |           |                   |                   |           |                |             |                |         |                      |                   |
| 8         | P-9 + P-10   |  |           | 1.57                  |                      |           |             |         |                      | 6.08                    | 1.26        | 8.35    | 10.54     |                   |                   |           |                |             |                |         |                      | EX INLET SDIN-52  |

- (1) Enter the Basin Name from C Value Sheet
- (2) Basin Description linked to C-Value Sheet
- (3) Enter the Basin Name from C Value Sheet
- (4) Basin Area linked to C-Value Sheet
- (5) Composite C linked to C-Value Sheet
- (6) Time of Concentration linked to C-Value Sheet

- (7) =Column 4 x Column 5
- (8) =28.5\*P/(10+Column 6)\*0.786
- (9) =Column 7 x Column 8
- (10) =Column 6 x Column 21
- (11) Add the Basin Areas (7) to get the combined basin AC
- (12) =28.5\*P/(10+Column 10)\*0.786

- (13) Sum of Qs
- (14) Additional Street Overland Flow
- (15) Additional Street Overland Flow
- (16) Additional Pipe Flow
- (17) Additional Pipe Flow
- (18) Additional Pipe Flow

- (19) Additional Flow Length
- (20) Overland Velocity
- (21) =Column 16 / Column 20 / 60

**APPENDIX C**  
**Hydraulic Calculations**

# INLET MANAGEMENT

Worksheet Protected

| INLET NAME                         | <a href="#">INLET 1</a>    | <a href="#">INLET 2</a>  | <a href="#">Ex SDIN102 - Modified</a> |
|------------------------------------|----------------------------|--------------------------|---------------------------------------|
| Site Type (Urban or Rural)         | URBAN                      | URBAN                    | RURAL                                 |
| Inlet Application (Street or Area) | STREET                     | STREET                   | STREET                                |
| Hydraulic Condition                | On Grade                   | In Sump                  | On Grade                              |
| Inlet Type                         | CDOT/Denver 13 Combination | CDOT Type R Curb Opening | CDOT Type R Curb Opening              |

## USER-DEFINED INPUT

| <b>User-Defined Design Flows</b>              |                         |              |              |
|---|-------------------------|--------------|--------------|
| Minor $Q_{Known}$ (cfs)                       | 0.3                     | 1.9          | 1.7          |
| Major $Q_{Known}$ (cfs)                       | 0.6                     | 4.4          | 3.6          |
| <b>Bypass (Carry-Over) Flow from Upstream</b> |                         |              |              |
| Receive Bypass Flow from:                     | No Bypass Flow Received | User-Defined | User-Defined |
| Minor Bypass Flow Received, $Q_b$ (cfs)       | 0.0                     | 0.0          | 0.1          |
| Major Bypass Flow Received, $Q_b$ (cfs)       | 0.0                     | 0.0          | 12.3         |
| <b>Watershed Characteristics</b>              |                         |              |              |
| Subcatchment Area (acres)                     |                         |              |              |
| Percent Impervious                            |                         |              |              |
| NRCS Soil Type                                |                         |              |              |
| <b>Watershed Profile</b>                      |                         |              |              |
| Overland Slope (ft/ft)                        |                         |              |              |
| Overland Length (ft)                          |                         |              |              |
| Channel Slope (ft/ft)                         |                         |              |              |
| Channel Length (ft)                           |                         |              |              |
| <b>Minor Storm Rainfall Input</b>             |                         |              |              |
| Design Storm Return Period, $T_r$ (years)     |                         |              |              |
| One-Hour Precipitation, $P_1$ (inches)        |                         |              |              |
| <b>Major Storm Rainfall Input</b>             |                         |              |              |
| Design Storm Return Period, $T_r$ (years)     |                         |              |              |
| One-Hour Precipitation, $P_1$ (inches)        |                         |              |              |

## CALCULATED OUTPUT

|   |            |            |             |
|---|------------|------------|-------------|
| <b>Minor Total Design Peak Flow, <math>Q</math> (cfs)</b> | <b>0.3</b> | <b>1.9</b> | <b>1.8</b>  |
| <b>Major Total Design Peak Flow, <math>Q</math> (cfs)</b> | <b>0.6</b> | <b>4.4</b> | <b>15.9</b> |
| Minor Flow Bypassed Downstream, $Q_b$ (cfs)               | 0.1        | N/A        | 0.0         |
| Major Flow Bypassed Downstream, $Q_b$ (cfs)               | 0.2        | N/A        | 6.2         |

# INLET MANAGEMENT

Worksheet Protected

|                                    |                                       |                                      |
|------------------------------------|---------------------------------------|--------------------------------------|
| <b>INLET NAME</b>                  | <a href="#">Ex SDIN101 - Modified</a> | <a href="#">Ex SDIN52 - Modified</a> |
| Site Type (Urban or Rural)         | RURAL                                 | RURAL                                |
| Inlet Application (Street or Area) | STREET                                | STREET                               |
| Hydraulic Condition                | On Grade                              | On Grade                             |
| Inlet Type                         | CDOT Type R Curb Opening              | CDOT Type R Curb Opening             |

## USER-DEFINED INPUT

|   |              |              |
|---|--------------|--------------|
| <b>User-Defined Design Flows</b>              |              |              |
| Minor $Q_{\text{known}}$ (cfs)                | 6.6          | 4.5          |
| Major $Q_{\text{known}}$ (cfs)                | 15.7         | 10.5         |
| <b>Bypass (Carry-Over) Flow from Upstream</b> |              |              |
| Receive Bypass Flow from:                     | User-Defined | User-Defined |
| Minor Bypass Flow Received, $Q_b$ (cfs)       | 0.0          | 0.0          |
| Major Bypass Flow Received, $Q_b$ (cfs)       | 6.2          | 6.5          |
| <b>Watershed Characteristics</b>              |              |              |
| Subcatchment Area (acres)                     |              |              |
| Percent Impervious                            |              |              |
| NRCS Soil Type                                |              |              |
| <b>Watershed Profile</b>                      |              |              |
| Overland Slope (ft/ft)                        |              |              |
| Overland Length (ft)                          |              |              |
| Channel Slope (ft/ft)                         |              |              |
| Channel Length (ft)                           |              |              |
| <b>Minor Storm Rainfall Input</b>             |              |              |
| Design Storm Return Period, $T_r$ (years)     |              |              |
| One-Hour Precipitation, $P_1$ (inches)        |              |              |
| <b>Major Storm Rainfall Input</b>             |              |              |
| Design Storm Return Period, $T_r$ (years)     |              |              |
| One-Hour Precipitation, $P_1$ (inches)        |              |              |

## CALCULATED OUTPUT

|   |             |             |
|---|-------------|-------------|
| <b>Minor Total Design Peak Flow, <math>Q</math> (cfs)</b> | <b>6.6</b>  | <b>4.5</b>  |
| <b>Major Total Design Peak Flow, <math>Q</math> (cfs)</b> | <b>21.9</b> | <b>17.0</b> |
| Minor Flow Bypassed Downstream, $Q_b$ (cfs)               | 0.0         | 0.0         |
| Major Flow Bypassed Downstream, $Q_b$ (cfs)               | 6.5         | 3.5         |

## ALLOWABLE CAPACITY FOR ONE-HALF OF STREET (Minor & Major Storm)

(Based on Regulated Criteria for Maximum Allowable Flow Depth and Spread)

**Project:** Kum & Go 2293 - Pinery & Bayou Gulch

**Inlet ID:** INLET 1

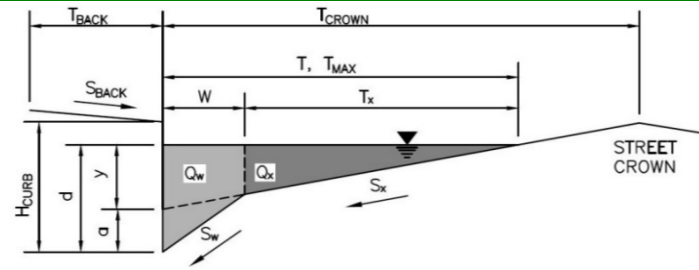

**Gutter Geometry:**

Maximum Allowable Width for Spread Behind Curb  
 Side Slope Behind Curb (leave blank for no conveyance credit behind curb)  
 Manning's Roughness Behind Curb (typically between 0.012 and 0.020)

|            |   |       |       |
|------------|---|-------|-------|
| $T_{BACK}$ | = | 0.5   | ft    |
| $S_{BACK}$ | = | 0.020 | ft/ft |
| $n_{BACK}$ | = | 0.020 |       |

Height of Curb at Gutter Flow Line  
 Distance from Curb Face to Street Crown  
 Gutter Width  
 Street Transverse Slope  
 Gutter Cross Slope (typically 2 inches over 24 inches or 0.083 ft/ft)  
 Street Longitudinal Slope - Enter 0 for sump condition  
 Manning's Roughness for Street Section (typically between 0.012 and 0.020)

|              |   |       |        |
|--------------|---|-------|--------|
| $H_{CURB}$   | = | 6.00  | inches |
| $T_{CROWN}$  | = | 30.0  | ft     |
| $W$          | = | 2.00  | ft     |
| $S_X$        | = | 0.020 | ft/ft  |
| $S_W$        | = | 0.083 | ft/ft  |
| $S_O$        | = | 0.040 | ft/ft  |
| $n_{STREET}$ | = | 0.013 |        |

Max. Allowable Spread for Minor & Major Storm  
 Max. Allowable Depth at Gutter Flowline for Minor & Major Storm  
 Allow Flow Depth at Street Crown (check box for yes, leave blank for no)

|           | Minor Storm | Major Storm              |                          |
|-----------|-------------|--------------------------|--------------------------|
| $T_{MAX}$ | =           | 30.0                     | ft                       |
| $d_{MAX}$ | =           | 6.0                      | inches                   |
|           |             | <input type="checkbox"/> | <input type="checkbox"/> |

MINOR STORM Allowable Capacity is based on Depth Criterion  
 MAJOR STORM Allowable Capacity is based on Depth Criterion

|             |   |      |      |     |
|-------------|---|------|------|-----|
| $Q_{allow}$ | = | 20.0 | 20.0 | cfs |
|-------------|---|------|------|-----|

**Minor storm max. allowable capacity GOOD - greater than the design flow given on sheet 'Inlet Management'**  
**Major storm max. allowable capacity GOOD - greater than the design flow given on sheet 'Inlet Management'**

# INLET ON A CONTINUOUS GRADE

MHFD-Inlet, Version 5.01 (April 2021)

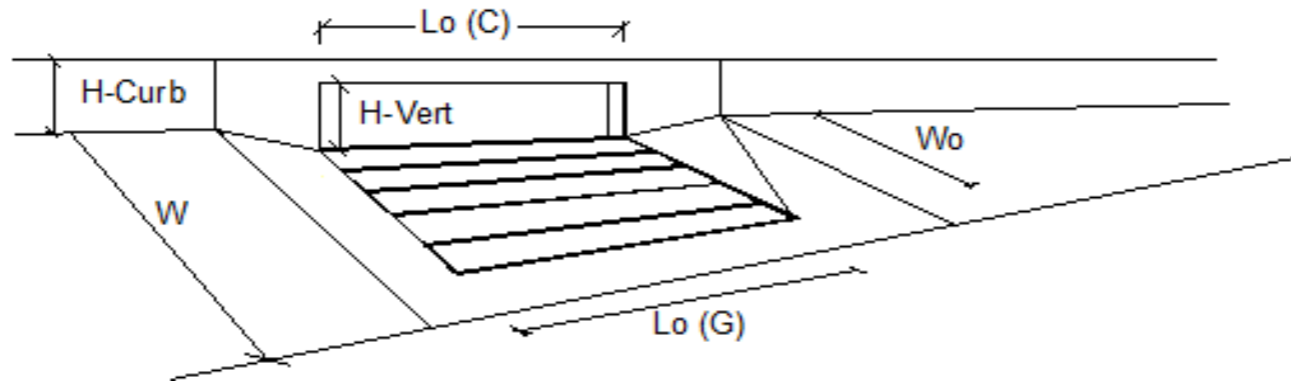

| Design Information (Input)  | MINOR                      |      | MAJOR |        |
|---|----------------------------|------|-------|--------|
| Type of Inlet   | CDOT/Denver 13 Combination |      |       |        |
| Local Depression (additional to continuous gutter depression 'a')                   | $a_{LOCAL} =$              | 2.0  | 2.0   | inches |
| Total Number of Units in the Inlet (Grate or Curb Opening)                          | No =                       | 1    | 1     |        |
| Length of a Single Unit Inlet (Grate or Curb Opening)                               | $L_o =$                    | 3.00 | 3.00  | ft     |
| Width of a Unit Grate (cannot be greater than W, Gutter Width)                      | $W_o =$                    | 1.73 | 1.73  | ft     |
| Clogging Factor for a Single Unit Grate (typical min. value = 0.5)                  | $C_{r-G} =$                | 0.50 | 0.50  |        |
| Clogging Factor for a Single Unit Curb Opening (typical min. value = 0.1)           | $C_{r-C} =$                | 0.10 | 0.10  |        |
| <b>Street Hydraulics: OK - <math>Q &lt; \text{Allowable Street Capacity}</math></b> |                            |      |       |        |
| Total Inlet Interception Capacity   | $Q =$                      | 0.2  | 0.4   | cfs    |
| Total Inlet Carry-Over Flow (flow bypassing inlet)                                  | $Q_b =$                    | 0.1  | 0.2   | cfs    |
| Capture Percentage = $Q_a/Q_o =$  | $C\% =$                    | 75   | 73    | %      |

**ALLOWABLE CAPACITY FOR ONE-HALF OF STREET (Minor & Major Storm)**

(Based on Regulated Criteria for Maximum Allowable Flow Depth and Spread)

Project: Kum & Go 2293 - Pinery & Bayou Gulch  
 Inlet ID: INLET 2

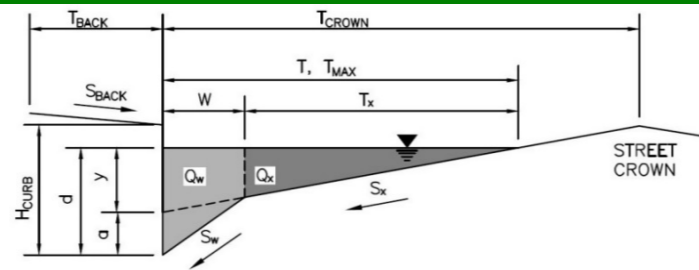

|  |   |                          |             |             |             |                          |                          |
|--|---|--------------------------|-------------|-------------|-------------|--------------------------|--------------------------|
| <b>Gutter Geometry:</b>  |   |                          |             |             |             |                          |                          |
| Maximum Allowable Width for Spread Behind Curb                             | $T_{BACK} = 0.5$ ft   |                          |             |             |             |                          |                          |
| Side Slope Behind Curb (leave blank for no conveyance credit behind curb)  | $S_{BACK} = 0.020$ ft/ft  |                          |             |             |             |                          |                          |
| Manning's Roughness Behind Curb (typically between 0.012 and 0.020)        | $n_{BACK} = 0.020$  |                          |             |             |             |                          |                          |
| Height of Curb at Gutter Flow Line   | $H_{CURB} = 6.00$ inches  |                          |             |             |             |                          |                          |
| Distance from Curb Face to Street Crown                                    | $T_{CROWN} = 24.0$ ft   |                          |             |             |             |                          |                          |
| Gutter Width   | $W = 2.00$ ft   |                          |             |             |             |                          |                          |
| Street Transverse Slope  | $S_X = 0.020$ ft/ft   |                          |             |             |             |                          |                          |
| Gutter Cross Slope (typically 2 inches over 24 inches or 0.083 ft/ft)      | $S_W = 0.083$ ft/ft   |                          |             |             |             |                          |                          |
| Street Longitudinal Slope - Enter 0 for sump condition                     | $S_O = 0.000$ ft/ft   |                          |             |             |             |                          |                          |
| Manning's Roughness for Street Section (typically between 0.012 and 0.020) | $n_{STREET} = 0.013$  |                          |             |             |             |                          |                          |
| Max. Allowable Spread for Minor & Major Storm                              | <table border="1"> <tr> <td></td> <td>Minor Storm</td> <td>Major Storm</td> </tr> <tr> <td><math>T_{MAX} =</math></td> <td>24.0</td> <td>24.0</td> </tr> </table>                   |                          | Minor Storm | Major Storm | $T_{MAX} =$ | 24.0                     | 24.0                     |
|  | Minor Storm   | Major Storm              |             |             |             |                          |                          |
| $T_{MAX} =$  | 24.0  | 24.0                     |             |             |             |                          |                          |
| Max. Allowable Depth at Gutter Flowline for Minor & Major Storm            | <table border="1"> <tr> <td></td> <td>Minor Storm</td> <td>Major Storm</td> </tr> <tr> <td><math>d_{MAX} =</math></td> <td>5.0</td> <td>6.0</td> </tr> </table>                     |                          | Minor Storm | Major Storm | $d_{MAX} =$ | 5.0                      | 6.0                      |
|  | Minor Storm   | Major Storm              |             |             |             |                          |                          |
| $d_{MAX} =$  | 5.0   | 6.0                      |             |             |             |                          |                          |
| Check boxes are not applicable in SUMP conditions                          | <table border="1"> <tr> <td></td> <td>Minor Storm</td> <td>Major Storm</td> </tr> <tr> <td></td> <td><input type="checkbox"/></td> <td><input type="checkbox"/></td> </tr> </table> |                          | Minor Storm | Major Storm |             | <input type="checkbox"/> | <input type="checkbox"/> |
|  | Minor Storm   | Major Storm              |             |             |             |                          |                          |
|  | <input type="checkbox"/>  | <input type="checkbox"/> |             |             |             |                          |                          |
| MINOR STORM Allowable Capacity is based on Depth Criterion                 |   |                          |             |             |             |                          |                          |
| MAJOR STORM Allowable Capacity is based on Depth Criterion                 |   |                          |             |             |             |                          |                          |
| $Q_{allow} =$  | <table border="1"> <tr> <td></td> <td>Minor Storm</td> <td>Major Storm</td> </tr> <tr> <td></td> <td>SUMP</td> <td>SUMP</td> </tr> </table>   |                          | Minor Storm | Major Storm |             | SUMP                     | SUMP                     |
|  | Minor Storm   | Major Storm              |             |             |             |                          |                          |
|  | SUMP  | SUMP                     |             |             |             |                          |                          |

# INLET IN A SUMP OR SAG LOCATION

MHFD-Inlet, Version 5.01 (April 2021)

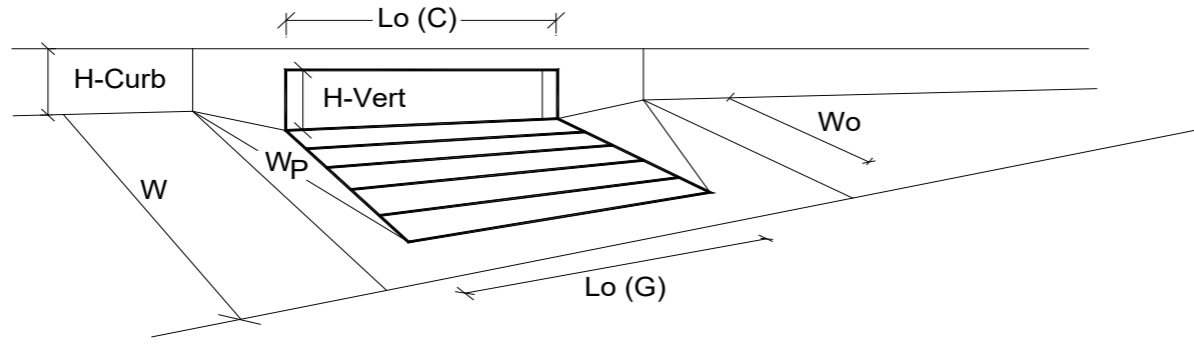

| <b>Design Information (Input)</b>  |                          | <table border="1" style="margin: auto;"> <thead> <tr> <th></th> <th>MINOR</th> <th>MAJOR</th> <th></th> </tr> </thead> <tbody> <tr> <td>Type =</td> <td colspan="2" style="text-align: center;">CDOT Type R Curb Opening</td> <td></td> </tr> <tr> <td><math>a_{local}</math> =</td> <td style="text-align: center;">3.00</td> <td style="text-align: center;">3.00</td> <td>inches</td> </tr> <tr> <td>No =</td> <td style="text-align: center;">1</td> <td style="text-align: center;">1</td> <td></td> </tr> <tr> <td>Ponding Depth =</td> <td style="text-align: center;">5.0</td> <td style="text-align: center;">6.0</td> <td>inches</td> </tr> <tr> <td></td> <td style="text-align: center;">MINOR</td> <td style="text-align: center;">MAJOR</td> <td><input type="checkbox"/> Override Depths</td> </tr> <tr> <td><math>L_o (G)</math> =</td> <td style="text-align: center;">N/A</td> <td style="text-align: center;">N/A</td> <td>feet</td> </tr> <tr> <td><math>W_o</math> =</td> <td style="text-align: center;">N/A</td> <td style="text-align: center;">N/A</td> <td>feet</td> </tr> <tr> <td><math>A_{ratio}</math> =</td> <td style="text-align: center;">N/A</td> <td style="text-align: center;">N/A</td> <td></td> </tr> <tr> <td><math>C_f (G)</math> =</td> <td style="text-align: center;">N/A</td> <td style="text-align: center;">N/A</td> <td></td> </tr> <tr> <td><math>C_w (G)</math> =</td> <td style="text-align: center;">N/A</td> <td style="text-align: center;">N/A</td> <td></td> </tr> <tr> <td><math>C_o (G)</math> =</td> <td style="text-align: center;">N/A</td> <td style="text-align: center;">N/A</td> <td></td> </tr> <tr> <td></td> <td style="text-align: center;">MINOR</td> <td style="text-align: center;">MAJOR</td> <td></td> </tr> <tr> <td><math>L_o (C)</math> =</td> <td style="text-align: center;">5.00</td> <td style="text-align: center;">5.00</td> <td>feet</td> </tr> <tr> <td><math>H_{vert}</math> =</td> <td style="text-align: center;">6.00</td> <td style="text-align: center;">6.00</td> <td>inches</td> </tr> <tr> <td><math>H_{throat}</math> =</td> <td style="text-align: center;">6.00</td> <td style="text-align: center;">6.00</td> <td>inches</td> </tr> <tr> <td>Theta =</td> <td style="text-align: center;">63.40</td> <td style="text-align: center;">63.40</td> <td>degrees</td> </tr> <tr> <td><math>W_p</math> =</td> <td style="text-align: center;">2.00</td> <td style="text-align: center;">2.00</td> <td>feet</td> </tr> <tr> <td><math>C_f (C)</math> =</td> <td style="text-align: center;">0.10</td> <td style="text-align: center;">0.10</td> <td></td> </tr> <tr> <td><math>C_w (C)</math> =</td> <td style="text-align: center;">3.60</td> <td style="text-align: center;">3.60</td> <td></td> </tr> <tr> <td><math>C_o (C)</math> =</td> <td style="text-align: center;">0.67</td> <td style="text-align: center;">0.67</td> <td></td> </tr> <tr> <td></td> <td style="text-align: center;">MINOR</td> <td style="text-align: center;">MAJOR</td> <td></td> </tr> <tr> <td><math>d_{Grate}</math> =</td> <td style="text-align: center;">N/A</td> <td style="text-align: center;">N/A</td> <td>ft</td> </tr> <tr> <td><math>d_{Curb}</math> =</td> <td style="text-align: center;">0.25</td> <td style="text-align: center;">0.33</td> <td>ft</td> </tr> <tr> <td><math>RF_{Combination}</math> =</td> <td style="text-align: center;">0.64</td> <td style="text-align: center;">0.77</td> <td></td> </tr> <tr> <td><math>RF_{Curb}</math> =</td> <td style="text-align: center;">1.00</td> <td style="text-align: center;">1.00</td> <td></td> </tr> <tr> <td><math>RF_{Grate}</math> =</td> <td style="text-align: center;">N/A</td> <td style="text-align: center;">N/A</td> <td></td> </tr> <tr> <td></td> <td style="text-align: center;">MINOR</td> <td style="text-align: center;">MAJOR</td> <td></td> </tr> <tr> <td><math>Q_a</math> =</td> <td style="text-align: center;">3.5</td> <td style="text-align: center;">5.4</td> <td>cfs</td> </tr> <tr> <td><math>Q_{PEAK REQUIRED}</math> =</td> <td style="text-align: center;">1.9</td> <td style="text-align: center;">4.4</td> <td>cfs</td> </tr> </tbody> </table> |  |  | MINOR | MAJOR |  | Type = | CDOT Type R Curb Opening |  |  | $a_{local}$ = | 3.00 | 3.00 | inches | No = | 1 | 1 |  | Ponding Depth = | 5.0 | 6.0 | inches |  | MINOR | MAJOR | <input type="checkbox"/> Override Depths | $L_o (G)$ = | N/A | N/A | feet | $W_o$ = | N/A | N/A | feet | $A_{ratio}$ = | N/A | N/A |  | $C_f (G)$ = | N/A | N/A |  | $C_w (G)$ = | N/A | N/A |  | $C_o (G)$ = | N/A | N/A |  |  | MINOR | MAJOR |  | $L_o (C)$ = | 5.00 | 5.00 | feet | $H_{vert}$ = | 6.00 | 6.00 | inches | $H_{throat}$ = | 6.00 | 6.00 | inches | Theta = | 63.40 | 63.40 | degrees | $W_p$ = | 2.00 | 2.00 | feet | $C_f (C)$ = | 0.10 | 0.10 |  | $C_w (C)$ = | 3.60 | 3.60 |  | $C_o (C)$ = | 0.67 | 0.67 |  |  | MINOR | MAJOR |  | $d_{Grate}$ = | N/A | N/A | ft | $d_{Curb}$ = | 0.25 | 0.33 | ft | $RF_{Combination}$ = | 0.64 | 0.77 |  | $RF_{Curb}$ = | 1.00 | 1.00 |  | $RF_{Grate}$ = | N/A | N/A |  |  | MINOR | MAJOR |  | $Q_a$ = | 3.5 | 5.4 | cfs | $Q_{PEAK REQUIRED}$ = | 1.9 | 4.4 | cfs |
|--|--------------------------|---|--|--|-------|-------|--|--------|--------------------------|--|--|---------------|------|------|--------|------|---|---|--|-----------------|-----|-----|--------|--|-------|-------|--|-------------|-----|-----|------|---------|-----|-----|------|---------------|-----|-----|--|-------------|-----|-----|--|-------------|-----|-----|--|-------------|-----|-----|--|--|-------|-------|--|-------------|------|------|------|--------------|------|------|--------|----------------|------|------|--------|---------|-------|-------|---------|---------|------|------|------|-------------|------|------|--|-------------|------|------|--|-------------|------|------|--|--|-------|-------|--|---------------|-----|-----|----|--------------|------|------|----|----------------------|------|------|--|---------------|------|------|--|----------------|-----|-----|--|--|-------|-------|--|---------|-----|-----|-----|-----------------------|-----|-----|-----|
|  | MINOR                    | MAJOR   |  |  |       |       |  |        |                          |  |  |               |      |      |        |      |   |   |  |                 |     |     |        |  |       |       |  |             |     |     |      |         |     |     |      |               |     |     |  |             |     |     |  |             |     |     |  |             |     |     |  |  |       |       |  |             |      |      |      |              |      |      |        |                |      |      |        |         |       |       |         |         |      |      |      |             |      |      |  |             |      |      |  |             |      |      |  |  |       |       |  |               |     |     |    |              |      |      |    |                      |      |      |  |               |      |      |  |                |     |     |  |  |       |       |  |         |     |     |     |                       |     |     |     |
| Type =   | CDOT Type R Curb Opening |   |  |  |       |       |  |        |                          |  |  |               |      |      |        |      |   |   |  |                 |     |     |        |  |       |       |  |             |     |     |      |         |     |     |      |               |     |     |  |             |     |     |  |             |     |     |  |             |     |     |  |  |       |       |  |             |      |      |      |              |      |      |        |                |      |      |        |         |       |       |         |         |      |      |      |             |      |      |  |             |      |      |  |             |      |      |  |  |       |       |  |               |     |     |    |              |      |      |    |                      |      |      |  |               |      |      |  |                |     |     |  |  |       |       |  |         |     |     |     |                       |     |     |     |
| $a_{local}$ =  | 3.00                     | 3.00  | inches                                   |  |       |       |  |        |                          |  |  |               |      |      |        |      |   |   |  |                 |     |     |        |  |       |       |  |             |     |     |      |         |     |     |      |               |     |     |  |             |     |     |  |             |     |     |  |             |     |     |  |  |       |       |  |             |      |      |      |              |      |      |        |                |      |      |        |         |       |       |         |         |      |      |      |             |      |      |  |             |      |      |  |             |      |      |  |  |       |       |  |               |     |     |    |              |      |      |    |                      |      |      |  |               |      |      |  |                |     |     |  |  |       |       |  |         |     |     |     |                       |     |     |     |
| No =   | 1                        | 1   |  |  |       |       |  |        |                          |  |  |               |      |      |        |      |   |   |  |                 |     |     |        |  |       |       |  |             |     |     |      |         |     |     |      |               |     |     |  |             |     |     |  |             |     |     |  |             |     |     |  |  |       |       |  |             |      |      |      |              |      |      |        |                |      |      |        |         |       |       |         |         |      |      |      |             |      |      |  |             |      |      |  |             |      |      |  |  |       |       |  |               |     |     |    |              |      |      |    |                      |      |      |  |               |      |      |  |                |     |     |  |  |       |       |  |         |     |     |     |                       |     |     |     |
| Ponding Depth =  | 5.0                      | 6.0   | inches                                   |  |       |       |  |        |                          |  |  |               |      |      |        |      |   |   |  |                 |     |     |        |  |       |       |  |             |     |     |      |         |     |     |      |               |     |     |  |             |     |     |  |             |     |     |  |             |     |     |  |  |       |       |  |             |      |      |      |              |      |      |        |                |      |      |        |         |       |       |         |         |      |      |      |             |      |      |  |             |      |      |  |             |      |      |  |  |       |       |  |               |     |     |    |              |      |      |    |                      |      |      |  |               |      |      |  |                |     |     |  |  |       |       |  |         |     |     |     |                       |     |     |     |
|  | MINOR                    | MAJOR   | <input type="checkbox"/> Override Depths |  |       |       |  |        |                          |  |  |               |      |      |        |      |   |   |  |                 |     |     |        |  |       |       |  |             |     |     |      |         |     |     |      |               |     |     |  |             |     |     |  |             |     |     |  |             |     |     |  |  |       |       |  |             |      |      |      |              |      |      |        |                |      |      |        |         |       |       |         |         |      |      |      |             |      |      |  |             |      |      |  |             |      |      |  |  |       |       |  |               |     |     |    |              |      |      |    |                      |      |      |  |               |      |      |  |                |     |     |  |  |       |       |  |         |     |     |     |                       |     |     |     |
| $L_o (G)$ =  | N/A                      | N/A   | feet                                     |  |       |       |  |        |                          |  |  |               |      |      |        |      |   |   |  |                 |     |     |        |  |       |       |  |             |     |     |      |         |     |     |      |               |     |     |  |             |     |     |  |             |     |     |  |             |     |     |  |  |       |       |  |             |      |      |      |              |      |      |        |                |      |      |        |         |       |       |         |         |      |      |      |             |      |      |  |             |      |      |  |             |      |      |  |  |       |       |  |               |     |     |    |              |      |      |    |                      |      |      |  |               |      |      |  |                |     |     |  |  |       |       |  |         |     |     |     |                       |     |     |     |
| $W_o$ =  | N/A                      | N/A   | feet                                     |  |       |       |  |        |                          |  |  |               |      |      |        |      |   |   |  |                 |     |     |        |  |       |       |  |             |     |     |      |         |     |     |      |               |     |     |  |             |     |     |  |             |     |     |  |             |     |     |  |  |       |       |  |             |      |      |      |              |      |      |        |                |      |      |        |         |       |       |         |         |      |      |      |             |      |      |  |             |      |      |  |             |      |      |  |  |       |       |  |               |     |     |    |              |      |      |    |                      |      |      |  |               |      |      |  |                |     |     |  |  |       |       |  |         |     |     |     |                       |     |     |     |
| $A_{ratio}$ =  | N/A                      | N/A   |  |  |       |       |  |        |                          |  |  |               |      |      |        |      |   |   |  |                 |     |     |        |  |       |       |  |             |     |     |      |         |     |     |      |               |     |     |  |             |     |     |  |             |     |     |  |             |     |     |  |  |       |       |  |             |      |      |      |              |      |      |        |                |      |      |        |         |       |       |         |         |      |      |      |             |      |      |  |             |      |      |  |             |      |      |  |  |       |       |  |               |     |     |    |              |      |      |    |                      |      |      |  |               |      |      |  |                |     |     |  |  |       |       |  |         |     |     |     |                       |     |     |     |
| $C_f (G)$ =  | N/A                      | N/A   |  |  |       |       |  |        |                          |  |  |               |      |      |        |      |   |   |  |                 |     |     |        |  |       |       |  |             |     |     |      |         |     |     |      |               |     |     |  |             |     |     |  |             |     |     |  |             |     |     |  |  |       |       |  |             |      |      |      |              |      |      |        |                |      |      |        |         |       |       |         |         |      |      |      |             |      |      |  |             |      |      |  |             |      |      |  |  |       |       |  |               |     |     |    |              |      |      |    |                      |      |      |  |               |      |      |  |                |     |     |  |  |       |       |  |         |     |     |     |                       |     |     |     |
| $C_w (G)$ =  | N/A                      | N/A   |  |  |       |       |  |        |                          |  |  |               |      |      |        |      |   |   |  |                 |     |     |        |  |       |       |  |             |     |     |      |         |     |     |      |               |     |     |  |             |     |     |  |             |     |     |  |             |     |     |  |  |       |       |  |             |      |      |      |              |      |      |        |                |      |      |        |         |       |       |         |         |      |      |      |             |      |      |  |             |      |      |  |             |      |      |  |  |       |       |  |               |     |     |    |              |      |      |    |                      |      |      |  |               |      |      |  |                |     |     |  |  |       |       |  |         |     |     |     |                       |     |     |     |
| $C_o (G)$ =  | N/A                      | N/A   |  |  |       |       |  |        |                          |  |  |               |      |      |        |      |   |   |  |                 |     |     |        |  |       |       |  |             |     |     |      |         |     |     |      |               |     |     |  |             |     |     |  |             |     |     |  |             |     |     |  |  |       |       |  |             |      |      |      |              |      |      |        |                |      |      |        |         |       |       |         |         |      |      |      |             |      |      |  |             |      |      |  |             |      |      |  |  |       |       |  |               |     |     |    |              |      |      |    |                      |      |      |  |               |      |      |  |                |     |     |  |  |       |       |  |         |     |     |     |                       |     |     |     |
|  | MINOR                    | MAJOR   |  |  |       |       |  |        |                          |  |  |               |      |      |        |      |   |   |  |                 |     |     |        |  |       |       |  |             |     |     |      |         |     |     |      |               |     |     |  |             |     |     |  |             |     |     |  |             |     |     |  |  |       |       |  |             |      |      |      |              |      |      |        |                |      |      |        |         |       |       |         |         |      |      |      |             |      |      |  |             |      |      |  |             |      |      |  |  |       |       |  |               |     |     |    |              |      |      |    |                      |      |      |  |               |      |      |  |                |     |     |  |  |       |       |  |         |     |     |     |                       |     |     |     |
| $L_o (C)$ =  | 5.00                     | 5.00  | feet                                     |  |       |       |  |        |                          |  |  |               |      |      |        |      |   |   |  |                 |     |     |        |  |       |       |  |             |     |     |      |         |     |     |      |               |     |     |  |             |     |     |  |             |     |     |  |             |     |     |  |  |       |       |  |             |      |      |      |              |      |      |        |                |      |      |        |         |       |       |         |         |      |      |      |             |      |      |  |             |      |      |  |             |      |      |  |  |       |       |  |               |     |     |    |              |      |      |    |                      |      |      |  |               |      |      |  |                |     |     |  |  |       |       |  |         |     |     |     |                       |     |     |     |
| $H_{vert}$ =   | 6.00                     | 6.00  | inches                                   |  |       |       |  |        |                          |  |  |               |      |      |        |      |   |   |  |                 |     |     |        |  |       |       |  |             |     |     |      |         |     |     |      |               |     |     |  |             |     |     |  |             |     |     |  |             |     |     |  |  |       |       |  |             |      |      |      |              |      |      |        |                |      |      |        |         |       |       |         |         |      |      |      |             |      |      |  |             |      |      |  |             |      |      |  |  |       |       |  |               |     |     |    |              |      |      |    |                      |      |      |  |               |      |      |  |                |     |     |  |  |       |       |  |         |     |     |     |                       |     |     |     |
| $H_{throat}$ =   | 6.00                     | 6.00  | inches                                   |  |       |       |  |        |                          |  |  |               |      |      |        |      |   |   |  |                 |     |     |        |  |       |       |  |             |     |     |      |         |     |     |      |               |     |     |  |             |     |     |  |             |     |     |  |             |     |     |  |  |       |       |  |             |      |      |      |              |      |      |        |                |      |      |        |         |       |       |         |         |      |      |      |             |      |      |  |             |      |      |  |             |      |      |  |  |       |       |  |               |     |     |    |              |      |      |    |                      |      |      |  |               |      |      |  |                |     |     |  |  |       |       |  |         |     |     |     |                       |     |     |     |
| Theta =  | 63.40                    | 63.40   | degrees                                  |  |       |       |  |        |                          |  |  |               |      |      |        |      |   |   |  |                 |     |     |        |  |       |       |  |             |     |     |      |         |     |     |      |               |     |     |  |             |     |     |  |             |     |     |  |             |     |     |  |  |       |       |  |             |      |      |      |              |      |      |        |                |      |      |        |         |       |       |         |         |      |      |      |             |      |      |  |             |      |      |  |             |      |      |  |  |       |       |  |               |     |     |    |              |      |      |    |                      |      |      |  |               |      |      |  |                |     |     |  |  |       |       |  |         |     |     |     |                       |     |     |     |
| $W_p$ =  | 2.00                     | 2.00  | feet                                     |  |       |       |  |        |                          |  |  |               |      |      |        |      |   |   |  |                 |     |     |        |  |       |       |  |             |     |     |      |         |     |     |      |               |     |     |  |             |     |     |  |             |     |     |  |             |     |     |  |  |       |       |  |             |      |      |      |              |      |      |        |                |      |      |        |         |       |       |         |         |      |      |      |             |      |      |  |             |      |      |  |             |      |      |  |  |       |       |  |               |     |     |    |              |      |      |    |                      |      |      |  |               |      |      |  |                |     |     |  |  |       |       |  |         |     |     |     |                       |     |     |     |
| $C_f (C)$ =  | 0.10                     | 0.10  |  |  |       |       |  |        |                          |  |  |               |      |      |        |      |   |   |  |                 |     |     |        |  |       |       |  |             |     |     |      |         |     |     |      |               |     |     |  |             |     |     |  |             |     |     |  |             |     |     |  |  |       |       |  |             |      |      |      |              |      |      |        |                |      |      |        |         |       |       |         |         |      |      |      |             |      |      |  |             |      |      |  |             |      |      |  |  |       |       |  |               |     |     |    |              |      |      |    |                      |      |      |  |               |      |      |  |                |     |     |  |  |       |       |  |         |     |     |     |                       |     |     |     |
| $C_w (C)$ =  | 3.60                     | 3.60  |  |  |       |       |  |        |                          |  |  |               |      |      |        |      |   |   |  |                 |     |     |        |  |       |       |  |             |     |     |      |         |     |     |      |               |     |     |  |             |     |     |  |             |     |     |  |             |     |     |  |  |       |       |  |             |      |      |      |              |      |      |        |                |      |      |        |         |       |       |         |         |      |      |      |             |      |      |  |             |      |      |  |             |      |      |  |  |       |       |  |               |     |     |    |              |      |      |    |                      |      |      |  |               |      |      |  |                |     |     |  |  |       |       |  |         |     |     |     |                       |     |     |     |
| $C_o (C)$ =  | 0.67                     | 0.67  |  |  |       |       |  |        |                          |  |  |               |      |      |        |      |   |   |  |                 |     |     |        |  |       |       |  |             |     |     |      |         |     |     |      |               |     |     |  |             |     |     |  |             |     |     |  |             |     |     |  |  |       |       |  |             |      |      |      |              |      |      |        |                |      |      |        |         |       |       |         |         |      |      |      |             |      |      |  |             |      |      |  |             |      |      |  |  |       |       |  |               |     |     |    |              |      |      |    |                      |      |      |  |               |      |      |  |                |     |     |  |  |       |       |  |         |     |     |     |                       |     |     |     |
|  | MINOR                    | MAJOR   |  |  |       |       |  |        |                          |  |  |               |      |      |        |      |   |   |  |                 |     |     |        |  |       |       |  |             |     |     |      |         |     |     |      |               |     |     |  |             |     |     |  |             |     |     |  |             |     |     |  |  |       |       |  |             |      |      |      |              |      |      |        |                |      |      |        |         |       |       |         |         |      |      |      |             |      |      |  |             |      |      |  |             |      |      |  |  |       |       |  |               |     |     |    |              |      |      |    |                      |      |      |  |               |      |      |  |                |     |     |  |  |       |       |  |         |     |     |     |                       |     |     |     |
| $d_{Grate}$ =  | N/A                      | N/A   | ft                                       |  |       |       |  |        |                          |  |  |               |      |      |        |      |   |   |  |                 |     |     |        |  |       |       |  |             |     |     |      |         |     |     |      |               |     |     |  |             |     |     |  |             |     |     |  |             |     |     |  |  |       |       |  |             |      |      |      |              |      |      |        |                |      |      |        |         |       |       |         |         |      |      |      |             |      |      |  |             |      |      |  |             |      |      |  |  |       |       |  |               |     |     |    |              |      |      |    |                      |      |      |  |               |      |      |  |                |     |     |  |  |       |       |  |         |     |     |     |                       |     |     |     |
| $d_{Curb}$ =   | 0.25                     | 0.33  | ft                                       |  |       |       |  |        |                          |  |  |               |      |      |        |      |   |   |  |                 |     |     |        |  |       |       |  |             |     |     |      |         |     |     |      |               |     |     |  |             |     |     |  |             |     |     |  |             |     |     |  |  |       |       |  |             |      |      |      |              |      |      |        |                |      |      |        |         |       |       |         |         |      |      |      |             |      |      |  |             |      |      |  |             |      |      |  |  |       |       |  |               |     |     |    |              |      |      |    |                      |      |      |  |               |      |      |  |                |     |     |  |  |       |       |  |         |     |     |     |                       |     |     |     |
| $RF_{Combination}$ =   | 0.64                     | 0.77  |  |  |       |       |  |        |                          |  |  |               |      |      |        |      |   |   |  |                 |     |     |        |  |       |       |  |             |     |     |      |         |     |     |      |               |     |     |  |             |     |     |  |             |     |     |  |             |     |     |  |  |       |       |  |             |      |      |      |              |      |      |        |                |      |      |        |         |       |       |         |         |      |      |      |             |      |      |  |             |      |      |  |             |      |      |  |  |       |       |  |               |     |     |    |              |      |      |    |                      |      |      |  |               |      |      |  |                |     |     |  |  |       |       |  |         |     |     |     |                       |     |     |     |
| $RF_{Curb}$ =  | 1.00                     | 1.00  |  |  |       |       |  |        |                          |  |  |               |      |      |        |      |   |   |  |                 |     |     |        |  |       |       |  |             |     |     |      |         |     |     |      |               |     |     |  |             |     |     |  |             |     |     |  |             |     |     |  |  |       |       |  |             |      |      |      |              |      |      |        |                |      |      |        |         |       |       |         |         |      |      |      |             |      |      |  |             |      |      |  |             |      |      |  |  |       |       |  |               |     |     |    |              |      |      |    |                      |      |      |  |               |      |      |  |                |     |     |  |  |       |       |  |         |     |     |     |                       |     |     |     |
| $RF_{Grate}$ =   | N/A                      | N/A   |  |  |       |       |  |        |                          |  |  |               |      |      |        |      |   |   |  |                 |     |     |        |  |       |       |  |             |     |     |      |         |     |     |      |               |     |     |  |             |     |     |  |             |     |     |  |             |     |     |  |  |       |       |  |             |      |      |      |              |      |      |        |                |      |      |        |         |       |       |         |         |      |      |      |             |      |      |  |             |      |      |  |             |      |      |  |  |       |       |  |               |     |     |    |              |      |      |    |                      |      |      |  |               |      |      |  |                |     |     |  |  |       |       |  |         |     |     |     |                       |     |     |     |
|  | MINOR                    | MAJOR   |  |  |       |       |  |        |                          |  |  |               |      |      |        |      |   |   |  |                 |     |     |        |  |       |       |  |             |     |     |      |         |     |     |      |               |     |     |  |             |     |     |  |             |     |     |  |             |     |     |  |  |       |       |  |             |      |      |      |              |      |      |        |                |      |      |        |         |       |       |         |         |      |      |      |             |      |      |  |             |      |      |  |             |      |      |  |  |       |       |  |               |     |     |    |              |      |      |    |                      |      |      |  |               |      |      |  |                |     |     |  |  |       |       |  |         |     |     |     |                       |     |     |     |
| $Q_a$ =  | 3.5                      | 5.4   | cfs                                      |  |       |       |  |        |                          |  |  |               |      |      |        |      |   |   |  |                 |     |     |        |  |       |       |  |             |     |     |      |         |     |     |      |               |     |     |  |             |     |     |  |             |     |     |  |             |     |     |  |  |       |       |  |             |      |      |      |              |      |      |        |                |      |      |        |         |       |       |         |         |      |      |      |             |      |      |  |             |      |      |  |             |      |      |  |  |       |       |  |               |     |     |    |              |      |      |    |                      |      |      |  |               |      |      |  |                |     |     |  |  |       |       |  |         |     |     |     |                       |     |     |     |
| $Q_{PEAK REQUIRED}$ =  | 1.9                      | 4.4   | cfs                                      |  |       |       |  |        |                          |  |  |               |      |      |        |      |   |   |  |                 |     |     |        |  |       |       |  |             |     |     |      |         |     |     |      |               |     |     |  |             |     |     |  |             |     |     |  |             |     |     |  |  |       |       |  |             |      |      |      |              |      |      |        |                |      |      |        |         |       |       |         |         |      |      |      |             |      |      |  |             |      |      |  |             |      |      |  |  |       |       |  |               |     |     |    |              |      |      |    |                      |      |      |  |               |      |      |  |                |     |     |  |  |       |       |  |         |     |     |     |                       |     |     |     |
| Type of Inlet  | CDOT Type R Curb Opening |   |  |  |       |       |  |        |                          |  |  |               |      |      |        |      |   |   |  |                 |     |     |        |  |       |       |  |             |     |     |      |         |     |     |      |               |     |     |  |             |     |     |  |             |     |     |  |             |     |     |  |  |       |       |  |             |      |      |      |              |      |      |        |                |      |      |        |         |       |       |         |         |      |      |      |             |      |      |  |             |      |      |  |             |      |      |  |  |       |       |  |               |     |     |    |              |      |      |    |                      |      |      |  |               |      |      |  |                |     |     |  |  |       |       |  |         |     |     |     |                       |     |     |     |
| Local Depression (additional to continuous gutter depression 'a' from above) |                          |   |  |  |       |       |  |        |                          |  |  |               |      |      |        |      |   |   |  |                 |     |     |        |  |       |       |  |             |     |     |      |         |     |     |      |               |     |     |  |             |     |     |  |             |     |     |  |             |     |     |  |  |       |       |  |             |      |      |      |              |      |      |        |                |      |      |        |         |       |       |         |         |      |      |      |             |      |      |  |             |      |      |  |             |      |      |  |  |       |       |  |               |     |     |    |              |      |      |    |                      |      |      |  |               |      |      |  |                |     |     |  |  |       |       |  |         |     |     |     |                       |     |     |     |
| Number of Unit Inlets (Grate or Curb Opening)                                |                          |   |  |  |       |       |  |        |                          |  |  |               |      |      |        |      |   |   |  |                 |     |     |        |  |       |       |  |             |     |     |      |         |     |     |      |               |     |     |  |             |     |     |  |             |     |     |  |             |     |     |  |  |       |       |  |             |      |      |      |              |      |      |        |                |      |      |        |         |       |       |         |         |      |      |      |             |      |      |  |             |      |      |  |             |      |      |  |  |       |       |  |               |     |     |    |              |      |      |    |                      |      |      |  |               |      |      |  |                |     |     |  |  |       |       |  |         |     |     |     |                       |     |     |     |
| Water Depth at Flowline (outside of local depression)                        |                          |   |  |  |       |       |  |        |                          |  |  |               |      |      |        |      |   |   |  |                 |     |     |        |  |       |       |  |             |     |     |      |         |     |     |      |               |     |     |  |             |     |     |  |             |     |     |  |             |     |     |  |  |       |       |  |             |      |      |      |              |      |      |        |                |      |      |        |         |       |       |         |         |      |      |      |             |      |      |  |             |      |      |  |             |      |      |  |  |       |       |  |               |     |     |    |              |      |      |    |                      |      |      |  |               |      |      |  |                |     |     |  |  |       |       |  |         |     |     |     |                       |     |     |     |
| <b>Grate Information</b>   |                          |   |  |  |       |       |  |        |                          |  |  |               |      |      |        |      |   |   |  |                 |     |     |        |  |       |       |  |             |     |     |      |         |     |     |      |               |     |     |  |             |     |     |  |             |     |     |  |             |     |     |  |  |       |       |  |             |      |      |      |              |      |      |        |                |      |      |        |         |       |       |         |         |      |      |      |             |      |      |  |             |      |      |  |             |      |      |  |  |       |       |  |               |     |     |    |              |      |      |    |                      |      |      |  |               |      |      |  |                |     |     |  |  |       |       |  |         |     |     |     |                       |     |     |     |
| Length of a Unit Grate   |                          |   |  |  |       |       |  |        |                          |  |  |               |      |      |        |      |   |   |  |                 |     |     |        |  |       |       |  |             |     |     |      |         |     |     |      |               |     |     |  |             |     |     |  |             |     |     |  |             |     |     |  |  |       |       |  |             |      |      |      |              |      |      |        |                |      |      |        |         |       |       |         |         |      |      |      |             |      |      |  |             |      |      |  |             |      |      |  |  |       |       |  |               |     |     |    |              |      |      |    |                      |      |      |  |               |      |      |  |                |     |     |  |  |       |       |  |         |     |     |     |                       |     |     |     |
| Width of a Unit Grate  |                          |   |  |  |       |       |  |        |                          |  |  |               |      |      |        |      |   |   |  |                 |     |     |        |  |       |       |  |             |     |     |      |         |     |     |      |               |     |     |  |             |     |     |  |             |     |     |  |             |     |     |  |  |       |       |  |             |      |      |      |              |      |      |        |                |      |      |        |         |       |       |         |         |      |      |      |             |      |      |  |             |      |      |  |             |      |      |  |  |       |       |  |               |     |     |    |              |      |      |    |                      |      |      |  |               |      |      |  |                |     |     |  |  |       |       |  |         |     |     |     |                       |     |     |     |
| Area Opening Ratio for a Grate (typical values 0.15-0.90)                    |                          |   |  |  |       |       |  |        |                          |  |  |               |      |      |        |      |   |   |  |                 |     |     |        |  |       |       |  |             |     |     |      |         |     |     |      |               |     |     |  |             |     |     |  |             |     |     |  |             |     |     |  |  |       |       |  |             |      |      |      |              |      |      |        |                |      |      |        |         |       |       |         |         |      |      |      |             |      |      |  |             |      |      |  |             |      |      |  |  |       |       |  |               |     |     |    |              |      |      |    |                      |      |      |  |               |      |      |  |                |     |     |  |  |       |       |  |         |     |     |     |                       |     |     |     |
| Clogging Factor for a Single Grate (typical value 0.50 - 0.70)               |                          |   |  |  |       |       |  |        |                          |  |  |               |      |      |        |      |   |   |  |                 |     |     |        |  |       |       |  |             |     |     |      |         |     |     |      |               |     |     |  |             |     |     |  |             |     |     |  |             |     |     |  |  |       |       |  |             |      |      |      |              |      |      |        |                |      |      |        |         |       |       |         |         |      |      |      |             |      |      |  |             |      |      |  |             |      |      |  |  |       |       |  |               |     |     |    |              |      |      |    |                      |      |      |  |               |      |      |  |                |     |     |  |  |       |       |  |         |     |     |     |                       |     |     |     |
| Grate Weir Coefficient (typical value 2.15 - 3.60)                           |                          |   |  |  |       |       |  |        |                          |  |  |               |      |      |        |      |   |   |  |                 |     |     |        |  |       |       |  |             |     |     |      |         |     |     |      |               |     |     |  |             |     |     |  |             |     |     |  |             |     |     |  |  |       |       |  |             |      |      |      |              |      |      |        |                |      |      |        |         |       |       |         |         |      |      |      |             |      |      |  |             |      |      |  |             |      |      |  |  |       |       |  |               |     |     |    |              |      |      |    |                      |      |      |  |               |      |      |  |                |     |     |  |  |       |       |  |         |     |     |     |                       |     |     |     |
| Grate Orifice Coefficient (typical value 0.60 - 0.80)                        |                          |   |  |  |       |       |  |        |                          |  |  |               |      |      |        |      |   |   |  |                 |     |     |        |  |       |       |  |             |     |     |      |         |     |     |      |               |     |     |  |             |     |     |  |             |     |     |  |             |     |     |  |  |       |       |  |             |      |      |      |              |      |      |        |                |      |      |        |         |       |       |         |         |      |      |      |             |      |      |  |             |      |      |  |             |      |      |  |  |       |       |  |               |     |     |    |              |      |      |    |                      |      |      |  |               |      |      |  |                |     |     |  |  |       |       |  |         |     |     |     |                       |     |     |     |
| <b>Curb Opening Information</b>  |                          |   |  |  |       |       |  |        |                          |  |  |               |      |      |        |      |   |   |  |                 |     |     |        |  |       |       |  |             |     |     |      |         |     |     |      |               |     |     |  |             |     |     |  |             |     |     |  |             |     |     |  |  |       |       |  |             |      |      |      |              |      |      |        |                |      |      |        |         |       |       |         |         |      |      |      |             |      |      |  |             |      |      |  |             |      |      |  |  |       |       |  |               |     |     |    |              |      |      |    |                      |      |      |  |               |      |      |  |                |     |     |  |  |       |       |  |         |     |     |     |                       |     |     |     |
| Length of a Unit Curb Opening  |                          |   |  |  |       |       |  |        |                          |  |  |               |      |      |        |      |   |   |  |                 |     |     |        |  |       |       |  |             |     |     |      |         |     |     |      |               |     |     |  |             |     |     |  |             |     |     |  |             |     |     |  |  |       |       |  |             |      |      |      |              |      |      |        |                |      |      |        |         |       |       |         |         |      |      |      |             |      |      |  |             |      |      |  |             |      |      |  |  |       |       |  |               |     |     |    |              |      |      |    |                      |      |      |  |               |      |      |  |                |     |     |  |  |       |       |  |         |     |     |     |                       |     |     |     |
| Height of Vertical Curb Opening in Inches                                    |                          |   |  |  |       |       |  |        |                          |  |  |               |      |      |        |      |   |   |  |                 |     |     |        |  |       |       |  |             |     |     |      |         |     |     |      |               |     |     |  |             |     |     |  |             |     |     |  |             |     |     |  |  |       |       |  |             |      |      |      |              |      |      |        |                |      |      |        |         |       |       |         |         |      |      |      |             |      |      |  |             |      |      |  |             |      |      |  |  |       |       |  |               |     |     |    |              |      |      |    |                      |      |      |  |               |      |      |  |                |     |     |  |  |       |       |  |         |     |     |     |                       |     |     |     |
| Height of Curb Orifice Throat in Inches                                      |                          |   |  |  |       |       |  |        |                          |  |  |               |      |      |        |      |   |   |  |                 |     |     |        |  |       |       |  |             |     |     |      |         |     |     |      |               |     |     |  |             |     |     |  |             |     |     |  |             |     |     |  |  |       |       |  |             |      |      |      |              |      |      |        |                |      |      |        |         |       |       |         |         |      |      |      |             |      |      |  |             |      |      |  |             |      |      |  |  |       |       |  |               |     |     |    |              |      |      |    |                      |      |      |  |               |      |      |  |                |     |     |  |  |       |       |  |         |     |     |     |                       |     |     |     |
| Angle of Throat (see USDCM Figure ST-5)                                      |                          |   |  |  |       |       |  |        |                          |  |  |               |      |      |        |      |   |   |  |                 |     |     |        |  |       |       |  |             |     |     |      |         |     |     |      |               |     |     |  |             |     |     |  |             |     |     |  |             |     |     |  |  |       |       |  |             |      |      |      |              |      |      |        |                |      |      |        |         |       |       |         |         |      |      |      |             |      |      |  |             |      |      |  |             |      |      |  |  |       |       |  |               |     |     |    |              |      |      |    |                      |      |      |  |               |      |      |  |                |     |     |  |  |       |       |  |         |     |     |     |                       |     |     |     |
| Side Width for Depression Pan (typically the gutter width of 2 feet)         |                          |   |  |  |       |       |  |        |                          |  |  |               |      |      |        |      |   |   |  |                 |     |     |        |  |       |       |  |             |     |     |      |         |     |     |      |               |     |     |  |             |     |     |  |             |     |     |  |             |     |     |  |  |       |       |  |             |      |      |      |              |      |      |        |                |      |      |        |         |       |       |         |         |      |      |      |             |      |      |  |             |      |      |  |             |      |      |  |  |       |       |  |               |     |     |    |              |      |      |    |                      |      |      |  |               |      |      |  |                |     |     |  |  |       |       |  |         |     |     |     |                       |     |     |     |
| Clogging Factor for a Single Curb Opening (typical value 0.10)               |                          |   |  |  |       |       |  |        |                          |  |  |               |      |      |        |      |   |   |  |                 |     |     |        |  |       |       |  |             |     |     |      |         |     |     |      |               |     |     |  |             |     |     |  |             |     |     |  |             |     |     |  |  |       |       |  |             |      |      |      |              |      |      |        |                |      |      |        |         |       |       |         |         |      |      |      |             |      |      |  |             |      |      |  |             |      |      |  |  |       |       |  |               |     |     |    |              |      |      |    |                      |      |      |  |               |      |      |  |                |     |     |  |  |       |       |  |         |     |     |     |                       |     |     |     |
| Curb Opening Weir Coefficient (typical value 2.3-3.7)                        |                          |   |  |  |       |       |  |        |                          |  |  |               |      |      |        |      |   |   |  |                 |     |     |        |  |       |       |  |             |     |     |      |         |     |     |      |               |     |     |  |             |     |     |  |             |     |     |  |             |     |     |  |  |       |       |  |             |      |      |      |              |      |      |        |                |      |      |        |         |       |       |         |         |      |      |      |             |      |      |  |             |      |      |  |             |      |      |  |  |       |       |  |               |     |     |    |              |      |      |    |                      |      |      |  |               |      |      |  |                |     |     |  |  |       |       |  |         |     |     |     |                       |     |     |     |
| Curb Opening Orifice Coefficient (typical value 0.60 - 0.70)                 |                          |   |  |  |       |       |  |        |                          |  |  |               |      |      |        |      |   |   |  |                 |     |     |        |  |       |       |  |             |     |     |      |         |     |     |      |               |     |     |  |             |     |     |  |             |     |     |  |             |     |     |  |  |       |       |  |             |      |      |      |              |      |      |        |                |      |      |        |         |       |       |         |         |      |      |      |             |      |      |  |             |      |      |  |             |      |      |  |  |       |       |  |               |     |     |    |              |      |      |    |                      |      |      |  |               |      |      |  |                |     |     |  |  |       |       |  |         |     |     |     |                       |     |     |     |
| <b>Low Head Performance Reduction (Calculated)</b>                           |                          |   |  |  |       |       |  |        |                          |  |  |               |      |      |        |      |   |   |  |                 |     |     |        |  |       |       |  |             |     |     |      |         |     |     |      |               |     |     |  |             |     |     |  |             |     |     |  |             |     |     |  |  |       |       |  |             |      |      |      |              |      |      |        |                |      |      |        |         |       |       |         |         |      |      |      |             |      |      |  |             |      |      |  |             |      |      |  |  |       |       |  |               |     |     |    |              |      |      |    |                      |      |      |  |               |      |      |  |                |     |     |  |  |       |       |  |         |     |     |     |                       |     |     |     |
| Depth for Grate Midwidth   |                          |   |  |  |       |       |  |        |                          |  |  |               |      |      |        |      |   |   |  |                 |     |     |        |  |       |       |  |             |     |     |      |         |     |     |      |               |     |     |  |             |     |     |  |             |     |     |  |             |     |     |  |  |       |       |  |             |      |      |      |              |      |      |        |                |      |      |        |         |       |       |         |         |      |      |      |             |      |      |  |             |      |      |  |             |      |      |  |  |       |       |  |               |     |     |    |              |      |      |    |                      |      |      |  |               |      |      |  |                |     |     |  |  |       |       |  |         |     |     |     |                       |     |     |     |
| Depth for Curb Opening Weir Equation   |                          |   |  |  |       |       |  |        |                          |  |  |               |      |      |        |      |   |   |  |                 |     |     |        |  |       |       |  |             |     |     |      |         |     |     |      |               |     |     |  |             |     |     |  |             |     |     |  |             |     |     |  |  |       |       |  |             |      |      |      |              |      |      |        |                |      |      |        |         |       |       |         |         |      |      |      |             |      |      |  |             |      |      |  |             |      |      |  |  |       |       |  |               |     |     |    |              |      |      |    |                      |      |      |  |               |      |      |  |                |     |     |  |  |       |       |  |         |     |     |     |                       |     |     |     |
| Combination Inlet Performance Reduction Factor for Long Inlets               |                          |   |  |  |       |       |  |        |                          |  |  |               |      |      |        |      |   |   |  |                 |     |     |        |  |       |       |  |             |     |     |      |         |     |     |      |               |     |     |  |             |     |     |  |             |     |     |  |             |     |     |  |  |       |       |  |             |      |      |      |              |      |      |        |                |      |      |        |         |       |       |         |         |      |      |      |             |      |      |  |             |      |      |  |             |      |      |  |  |       |       |  |               |     |     |    |              |      |      |    |                      |      |      |  |               |      |      |  |                |     |     |  |  |       |       |  |         |     |     |     |                       |     |     |     |
| Curb Opening Performance Reduction Factor for Long Inlets                    |                          |   |  |  |       |       |  |        |                          |  |  |               |      |      |        |      |   |   |  |                 |     |     |        |  |       |       |  |             |     |     |      |         |     |     |      |               |     |     |  |             |     |     |  |             |     |     |  |             |     |     |  |  |       |       |  |             |      |      |      |              |      |      |        |                |      |      |        |         |       |       |         |         |      |      |      |             |      |      |  |             |      |      |  |             |      |      |  |  |       |       |  |               |     |     |    |              |      |      |    |                      |      |      |  |               |      |      |  |                |     |     |  |  |       |       |  |         |     |     |     |                       |     |     |     |
| Grated Inlet Performance Reduction Factor for Long Inlets                    |                          |   |  |  |       |       |  |        |                          |  |  |               |      |      |        |      |   |   |  |                 |     |     |        |  |       |       |  |             |     |     |      |         |     |     |      |               |     |     |  |             |     |     |  |             |     |     |  |             |     |     |  |  |       |       |  |             |      |      |      |              |      |      |        |                |      |      |        |         |       |       |         |         |      |      |      |             |      |      |  |             |      |      |  |             |      |      |  |  |       |       |  |               |     |     |    |              |      |      |    |                      |      |      |  |               |      |      |  |                |     |     |  |  |       |       |  |         |     |     |     |                       |     |     |     |
| Total Inlet Interception Capacity (assumes clogged condition)                |                          |   |  |  |       |       |  |        |                          |  |  |               |      |      |        |      |   |   |  |                 |     |     |        |  |       |       |  |             |     |     |      |         |     |     |      |               |     |     |  |             |     |     |  |             |     |     |  |             |     |     |  |  |       |       |  |             |      |      |      |              |      |      |        |                |      |      |        |         |       |       |         |         |      |      |      |             |      |      |  |             |      |      |  |             |      |      |  |  |       |       |  |               |     |     |    |              |      |      |    |                      |      |      |  |               |      |      |  |                |     |     |  |  |       |       |  |         |     |     |     |                       |     |     |     |
| <b>Inlet Capacity IS GOOD for Minor and Major Storms(&gt;Q PEAK)</b>         |                          |   |  |  |       |       |  |        |                          |  |  |               |      |      |        |      |   |   |  |                 |     |     |        |  |       |       |  |             |     |     |      |         |     |     |      |               |     |     |  |             |     |     |  |             |     |     |  |             |     |     |  |  |       |       |  |             |      |      |      |              |      |      |        |                |      |      |        |         |       |       |         |         |      |      |      |             |      |      |  |             |      |      |  |             |      |      |  |  |       |       |  |               |     |     |    |              |      |      |    |                      |      |      |  |               |      |      |  |                |     |     |  |  |       |       |  |         |     |     |     |                       |     |     |     |

**Warning 5: The width of unit is greater than the gutter width.**

**ALLOWABLE CAPACITY FOR ONE-HALF OF STREET (Minor & Major Storm)**

(Based on Regulated Criteria for Maximum Allowable Flow Depth and Spread)

Project: Kum & Go 2293 - Pinery & Bayou Gulch  
 Inlet ID: Ex SDIN102 - Modified

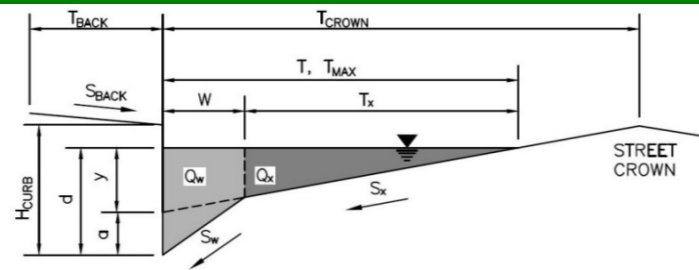

|  |  |
|--|--|
| <b>Gutter Geometry:</b>  |  |
| Maximum Allowable Width for Spread Behind Curb   | $T_{BACK} = 18.0$ ft   |
| Side Slope Behind Curb (leave blank for no conveyance credit behind curb)  | $S_{BACK} = 0.020$ ft/ft   |
| Manning's Roughness Behind Curb (typically between 0.012 and 0.020)  | $n_{BACK} = 0.020$   |
| Height of Curb at Gutter Flow Line   | $H_{CURB} = 4.00$ inches   |
| Distance from Curb Face to Street Crown  | $T_{CROWN} = 17.0$ ft  |
| Gutter Width   | $W = 2.00$ ft  |
| Street Transverse Slope  | $S_X = 0.020$ ft/ft  |
| Gutter Cross Slope (typically 2 inches over 24 inches or 0.083 ft/ft)  | $S_W = 0.083$ ft/ft  |
| Street Longitudinal Slope - Enter 0 for sump condition   | $S_O = 0.025$ ft/ft  |
| Manning's Roughness for Street Section (typically between 0.012 and 0.020)                                       | $n_{STREET} = 0.016$   |
| Max. Allowable Spread for Minor & Major Storm  | $T_{MAX} = \begin{matrix} \text{Minor Storm} & \text{Major Storm} \\ 17.0 & 17.0 \end{matrix}$ ft    |
| Max. Allowable Depth at Gutter Flowline for Minor & Major Storm  | $d_{MAX} = \begin{matrix} \text{Minor Storm} & \text{Major Storm} \\ 4.0 & 12.0 \end{matrix}$ inches |
| Allow Flow Depth at Street Crown (check box for yes, leave blank for no)   | <input type="checkbox"/> <input checked="" type="checkbox"/>   |
| MINOR STORM Allowable Capacity is based on Depth Criterion   |  |
| MAJOR STORM Allowable Capacity is based on Depth Criterion   |  |
| <b>Minor storm max. allowable capacity GOOD - greater than the design flow given on sheet 'Inlet Management'</b> |  |
| <b>Major storm max. allowable capacity GOOD - greater than the design flow given on sheet 'Inlet Management'</b> |  |
|  | $Q_{allow} = \begin{matrix} \text{Minor Storm} & \text{Major Storm} \\ 5.4 & 146.4 \end{matrix}$ cfs |

# INLET ON A CONTINUOUS GRADE

*MHFD-Inlet, Version 5.01 (April 2021)*

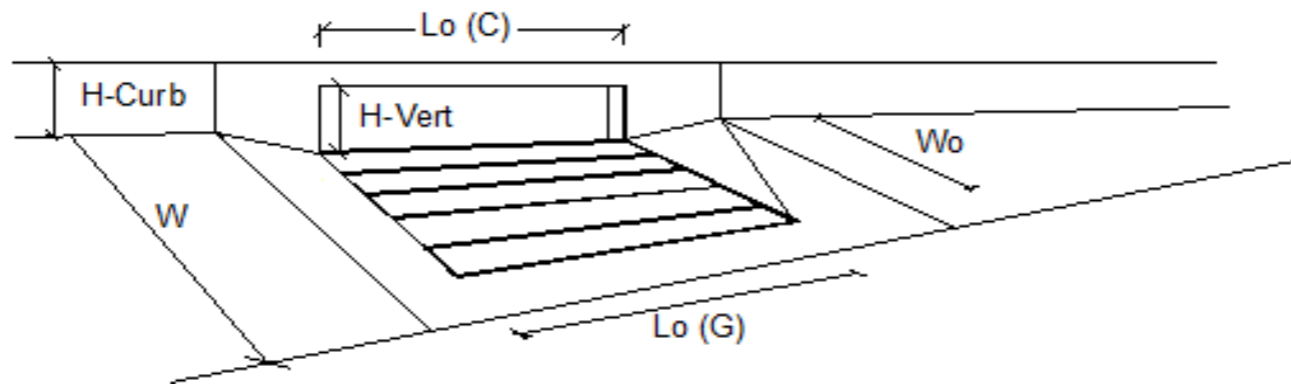

| Design Information (Input)  | MINOR                    |  | MAJOR |  |
|---|--------------------------|--|-------|--|
| Type of Inlet   | CDOT Type R Curb Opening |  |       |  |
| Local Depression (additional to continuous gutter depression 'a')         |                          |  |       |  |
| Total Number of Units in the Inlet (Grate or Curb Opening)                | No = 1                   |  | 1     |  |
| Length of a Single Unit Inlet (Grate or Curb Opening)                     | Lo = 10.00               |  | 10.00 |  |
| Width of a Unit Grate (cannot be greater than W, Gutter Width)            | Wo = N/A                 |  | N/A   |  |
| Clogging Factor for a Single Unit Grate (typical min. value = 0.5)        | C <sub>r-G</sub> = N/A   |  | N/A   |  |
| Clogging Factor for a Single Unit Curb Opening (typical min. value = 0.1) | C <sub>r-C</sub> = 0.10  |  | 0.10  |  |
| <b>Street Hydraulics: OK - Q &lt; Allowable Street Capacity'</b>          |                          |  |       |  |
| Total Inlet Interception Capacity   | Q = 1.8                  |  | 9.8   |  |
| Total Inlet Carry-Over Flow (flow bypassing inlet)                        | Q <sub>b</sub> = 0.0     |  | 6.2   |  |
| Capture Percentage = Q <sub>a</sub> /Q <sub>o</sub> =                     | C% = 100                 |  | 61    |  |

## ALLOWABLE CAPACITY FOR ONE-HALF OF STREET (Minor & Major Storm)

(Based on Regulated Criteria for Maximum Allowable Flow Depth and Spread)

**Project:** Kum & Go 2293 - Pinery & Bayou Gulch

**Inlet ID:** Ex SDIN101 - Modified

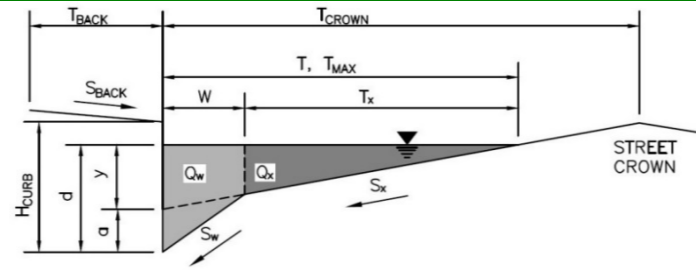

**Gutter Geometry:**

Maximum Allowable Width for Spread Behind Curb  
 Side Slope Behind Curb (leave blank for no conveyance credit behind curb)  
 Manning's Roughness Behind Curb (typically between 0.012 and 0.020)

$T_{BACK} = 18.0$  ft  
 $S_{BACK} = 0.020$  ft/ft  
 $n_{BACK} = 0.020$

Height of Curb at Gutter Flow Line  
 Distance from Curb Face to Street Crown  
 Gutter Width  
 Street Transverse Slope  
 Gutter Cross Slope (typically 2 inches over 24 inches or 0.083 ft/ft)  
 Street Longitudinal Slope - Enter 0 for sump condition  
 Manning's Roughness for Street Section (typically between 0.012 and 0.020)

$H_{CURB} = 4.00$  inches  
 $T_{CROWN} = 17.0$  ft  
 $W = 2.00$  ft  
 $S_X = 0.020$  ft/ft  
 $S_W = 0.083$  ft/ft  
 $S_O = 0.025$  ft/ft  
 $n_{STREET} = 0.016$

Max. Allowable Spread for Minor & Major Storm  
 Max. Allowable Depth at Gutter Flowline for Minor & Major Storm  
 Allow Flow Depth at Street Crown (check box for yes, leave blank for no)

|             | Minor Storm              | Major Storm                         |        |
|-------------|--------------------------|-------------------------------------|--------|
| $T_{MAX} =$ | 17.0                     | 17.0                                | ft     |
| $d_{MAX} =$ | 4.0                      | 12.0                                | inches |
|             | <input type="checkbox"/> | <input checked="" type="checkbox"/> |        |

MINOR STORM Allowable Capacity is based on Depth Criterion  
 MAJOR STORM Allowable Capacity is based on Depth Criterion

$Q_{allow} =$

|  | Minor Storm | Major Storm |     |
|--|-------------|-------------|-----|
|  | 5.4         | 146.4       | cfs |

**WARNING: MINOR STORM max. allowable capacity is less than the design flow given on sheet 'Inlet Management'**  
**Major storm max. allowable capacity GOOD - greater than the design flow given on sheet 'Inlet Management'**

# INLET ON A CONTINUOUS GRADE

*MHFD-Inlet, Version 5.01 (April 2021)*

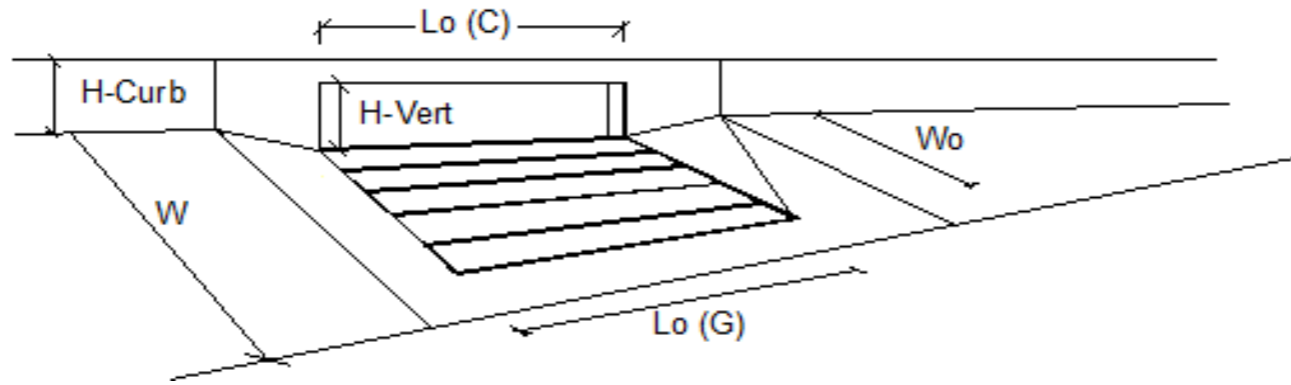

| Design Information (Input)  | MINOR                    | MAJOR |        |
|---|--------------------------|-------|--------|
| Type of Inlet   | CDOT Type R Curb Opening |       |        |
| Local Depression (additional to continuous gutter depression 'a')         | 5.0                      | 5.0   | inches |
| Total Number of Units in the Inlet (Grate or Curb Opening)                | 1                        | 1     |        |
| Length of a Single Unit Inlet (Grate or Curb Opening)                     | 15.00                    | 15.00 | ft     |
| Width of a Unit Grate (cannot be greater than W, Gutter Width)            | N/A                      | N/A   | ft     |
| Clogging Factor for a Single Unit Grate (typical min. value = 0.5)        | N/A                      | N/A   |        |
| Clogging Factor for a Single Unit Curb Opening (typical min. value = 0.1) | 0.10                     | 0.10  |        |
| <b>Street Hydraulics: WARNING: Q &gt; ALLOWABLE Q FOR MINOR STORM!</b>    |                          |       |        |
| Total Inlet Interception Capacity   | Q = 6.6                  | 15.4  | cfs    |
| Total Inlet Carry-Over Flow (flow bypassing inlet)                        | Q <sub>b</sub> = 0.0     | 6.5   | cfs    |
| Capture Percentage = $Q_a/Q_o =$  | C% = 100                 | 70    | %      |

**ALLOWABLE CAPACITY FOR ONE-HALF OF STREET (Minor & Major Storm)**

(Based on Regulated Criteria for Maximum Allowable Flow Depth and Spread)

Project: Kum & Go 2293 - Pinery & Bayou Gulch  
 Inlet ID: Ex SDIN52 - Modified

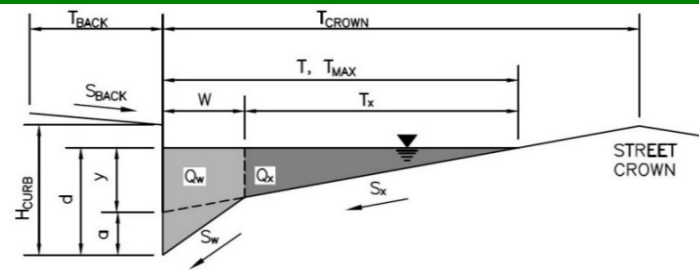

|  |   |                          |             |             |             |                          |                          |
|--|---|--------------------------|-------------|-------------|-------------|--------------------------|--------------------------|
| <b>Gutter Geometry:</b>  |   |                          |             |             |             |                          |                          |
| Maximum Allowable Width for Spread Behind Curb   | $T_{BACK} = 18.0$ ft  |                          |             |             |             |                          |                          |
| Side Slope Behind Curb (leave blank for no conveyance credit behind curb)  | $S_{BACK} = 0.020$ ft/ft  |                          |             |             |             |                          |                          |
| Manning's Roughness Behind Curb (typically between 0.012 and 0.020)  | $n_{BACK} = 0.020$  |                          |             |             |             |                          |                          |
| Height of Curb at Gutter Flow Line   | $H_{CURB} = 4.00$ inches  |                          |             |             |             |                          |                          |
| Distance from Curb Face to Street Crown  | $T_{CROWN} = 17.0$ ft   |                          |             |             |             |                          |                          |
| Gutter Width   | $W = 2.00$ ft   |                          |             |             |             |                          |                          |
| Street Transverse Slope  | $S_X = 0.020$ ft/ft   |                          |             |             |             |                          |                          |
| Gutter Cross Slope (typically 2 inches over 24 inches or 0.083 ft/ft)  | $S_W = 0.083$ ft/ft   |                          |             |             |             |                          |                          |
| Street Longitudinal Slope - Enter 0 for sump condition   | $S_O = 0.025$ ft/ft   |                          |             |             |             |                          |                          |
| Manning's Roughness for Street Section (typically between 0.012 and 0.020)                                       | $n_{STREET} = 0.016$  |                          |             |             |             |                          |                          |
| Max. Allowable Spread for Minor & Major Storm  | <table border="1"> <tr> <td></td> <td>Minor Storm</td> <td>Major Storm</td> </tr> <tr> <td><math>T_{MAX} =</math></td> <td>17.0</td> <td>17.0</td> </tr> </table>                   |                          | Minor Storm | Major Storm | $T_{MAX} =$ | 17.0                     | 17.0                     |
|  | Minor Storm   | Major Storm              |             |             |             |                          |                          |
| $T_{MAX} =$  | 17.0  | 17.0                     |             |             |             |                          |                          |
| Max. Allowable Depth at Gutter Flowline for Minor & Major Storm  | <table border="1"> <tr> <td></td> <td>Minor Storm</td> <td>Major Storm</td> </tr> <tr> <td><math>d_{MAX} =</math></td> <td>4.0</td> <td>12.0</td> </tr> </table>                    |                          | Minor Storm | Major Storm | $d_{MAX} =$ | 4.0                      | 12.0                     |
|  | Minor Storm   | Major Storm              |             |             |             |                          |                          |
| $d_{MAX} =$  | 4.0   | 12.0                     |             |             |             |                          |                          |
| Allow Flow Depth at Street Crown (check box for yes, leave blank for no)   | <table border="1"> <tr> <td></td> <td>Minor Storm</td> <td>Major Storm</td> </tr> <tr> <td></td> <td><input type="checkbox"/></td> <td><input type="checkbox"/></td> </tr> </table> |                          | Minor Storm | Major Storm |             | <input type="checkbox"/> | <input type="checkbox"/> |
|  | Minor Storm   | Major Storm              |             |             |             |                          |                          |
|  | <input type="checkbox"/>  | <input type="checkbox"/> |             |             |             |                          |                          |
| MINOR STORM Allowable Capacity is based on Depth Criterion   |   |                          |             |             |             |                          |                          |
| MAJOR STORM Allowable Capacity is based on Spread Criterion  |   |                          |             |             |             |                          |                          |
| <b>Minor storm max. allowable capacity GOOD - greater than the design flow given on sheet 'Inlet Management'</b> |   |                          |             |             |             |                          |                          |
| <b>Major storm max. allowable capacity GOOD - greater than the design flow given on sheet 'Inlet Management'</b> |   |                          |             |             |             |                          |                          |
| $Q_{allow} =$  | <table border="1"> <tr> <td></td> <td>Minor Storm</td> <td>Major Storm</td> </tr> <tr> <td></td> <td>5.4</td> <td>18.2</td> </tr> </table>  |                          | Minor Storm | Major Storm |             | 5.4                      | 18.2                     |
|  | Minor Storm   | Major Storm              |             |             |             |                          |                          |
|  | 5.4   | 18.2                     |             |             |             |                          |                          |

# INLET ON A CONTINUOUS GRADE

MHFD-Inlet, Version 5.01 (April 2021)

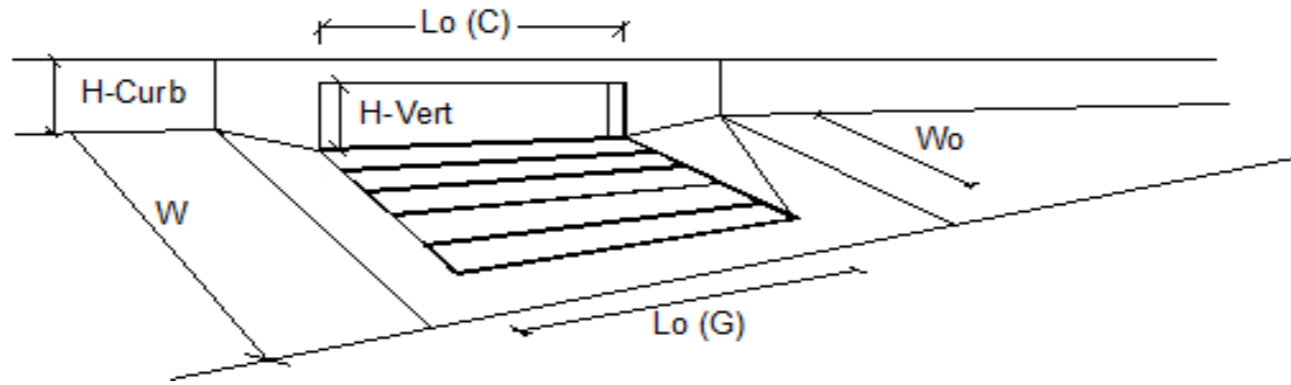

| Design Information (Input)  | MINOR                    | MAJOR |        |
|---|--------------------------|-------|--------|
| Type of Inlet   | CDOT Type R Curb Opening |       |        |
| Local Depression (additional to continuous gutter depression 'a')         | 5.0                      | 5.0   | inches |
| Total Number of Units in the Inlet (Grate or Curb Opening)                | 1                        | 1     |        |
| Length of a Single Unit Inlet (Grate or Curb Opening)                     | 15.00                    | 15.00 | ft     |
| Width of a Unit Grate (cannot be greater than W, Gutter Width)            | N/A                      | N/A   | ft     |
| Clogging Factor for a Single Unit Grate (typical min. value = 0.5)        | N/A                      | N/A   |        |
| Clogging Factor for a Single Unit Curb Opening (typical min. value = 0.1) | 0.10                     | 0.10  |        |
| <b>Street Hydraulics: OK - Q &lt; Allowable Street Capacity'</b>          |                          |       |        |
| Total Inlet Interception Capacity   | Q = 4.5                  | 13.5  | cfs    |
| Total Inlet Carry-Over Flow (flow bypassing inlet)                        | Q <sub>b</sub> = 0.0     | 3.5   | cfs    |
| Capture Percentage = Q <sub>a</sub> /Q <sub>o</sub> =                     | C% = 100                 | 80    | %      |

# STORMCAD LAYOUT

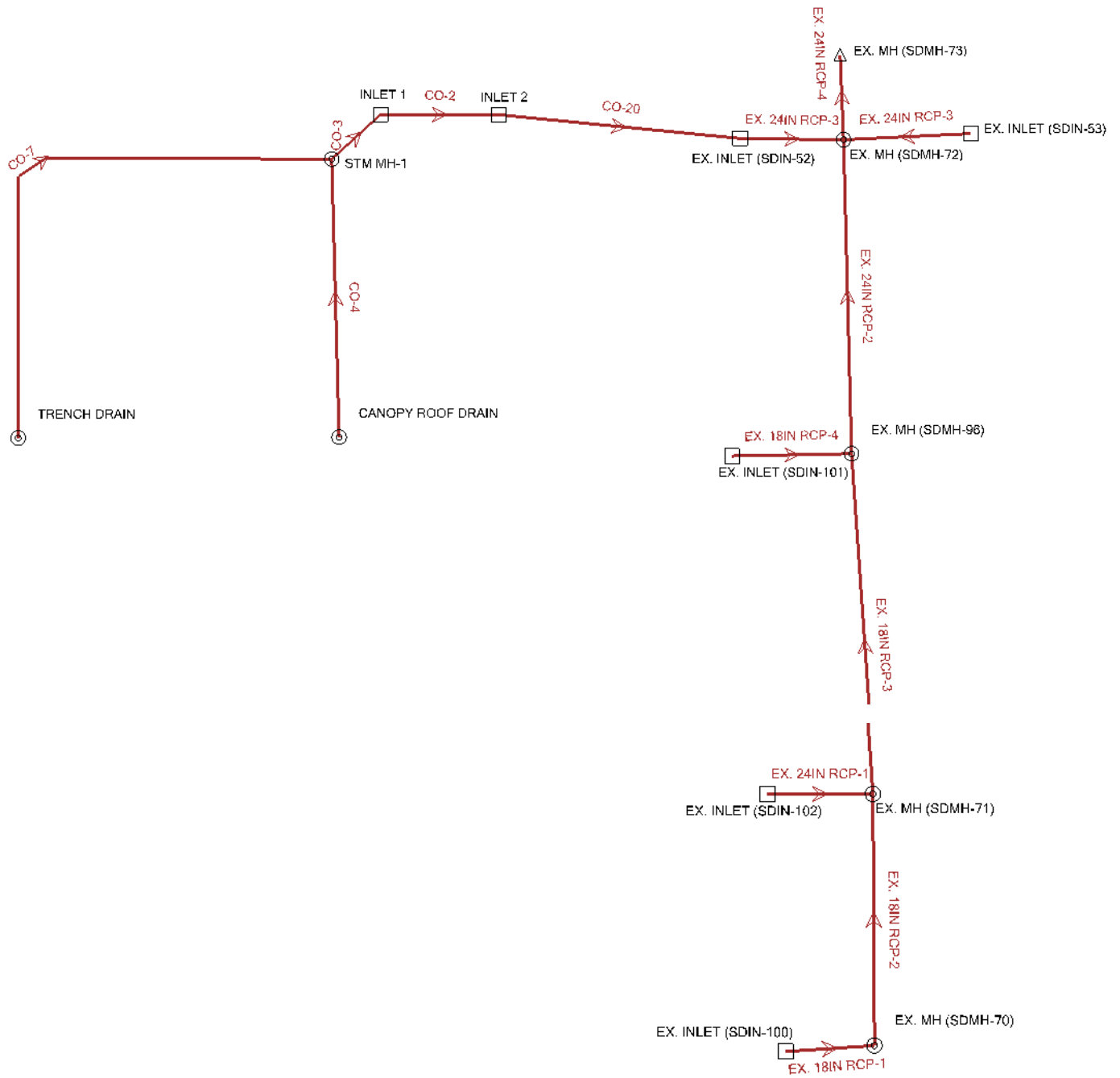

5-YEAR STORM EVENT

## Profile Report

### Engineering Profile - Profile - 1 (2293\_Parker\_Storm CAD - Updated.stsw)

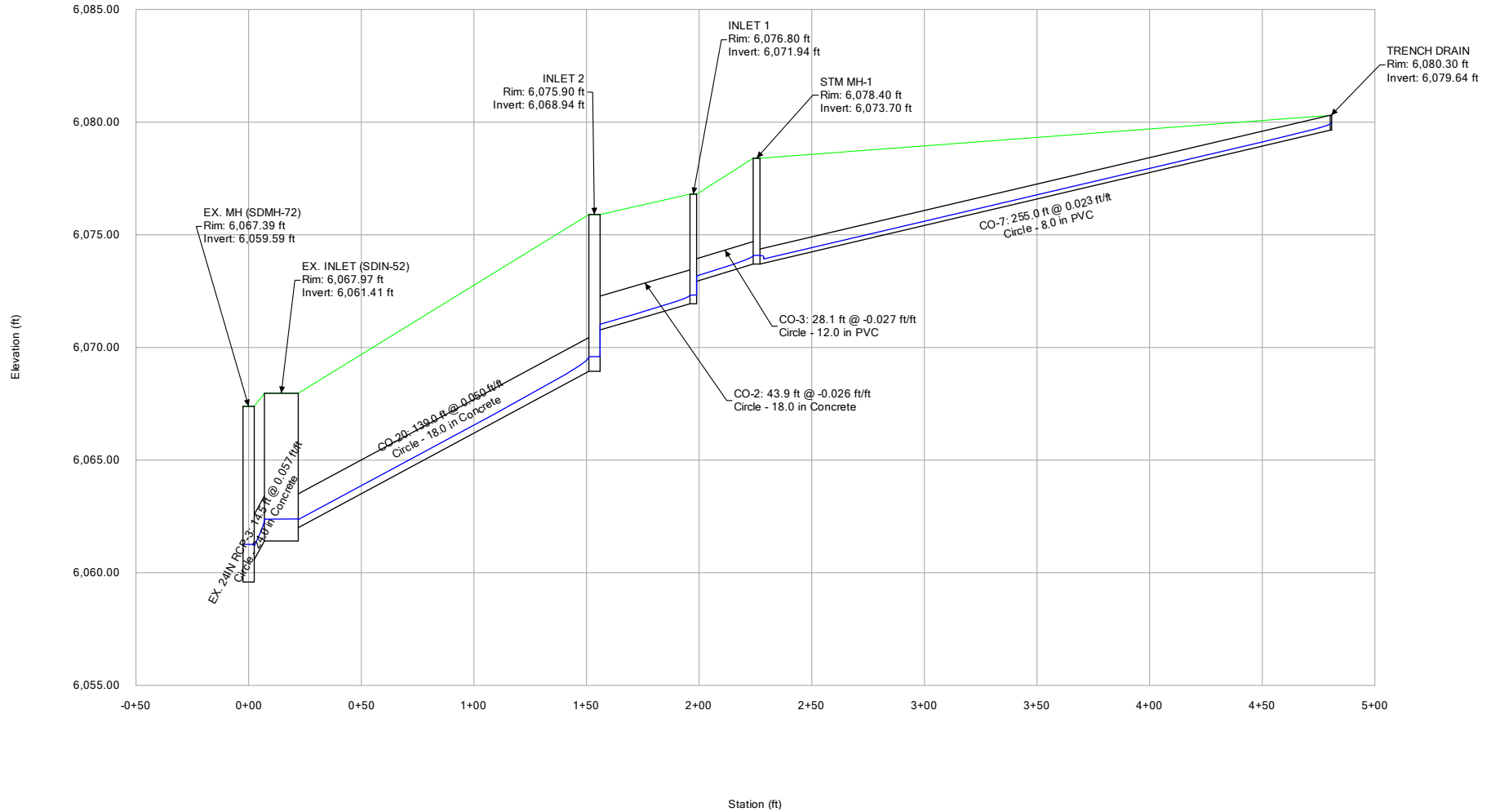

5-YEAR STORM EVENT

**Profile Report**  
**Engineering Profile - Profile - 2 (2293\_Parker\_Storm CAD - Updated.stsw)**

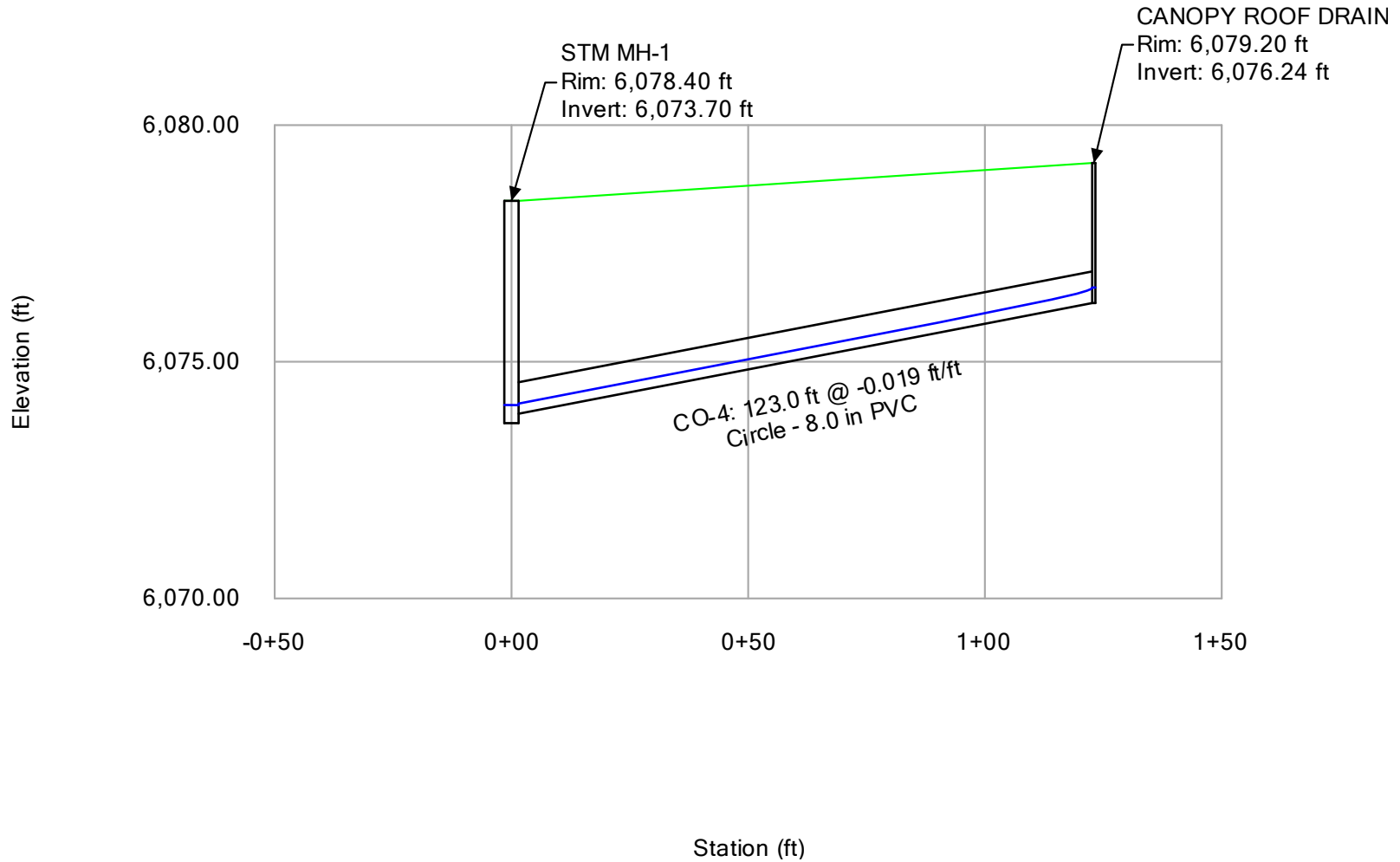

5-YEAR STORM EVENT

## Profile Report

### Engineering Profile - Profile - 4 (2293\_Parker\_Storm CAD - Updated.stsw)

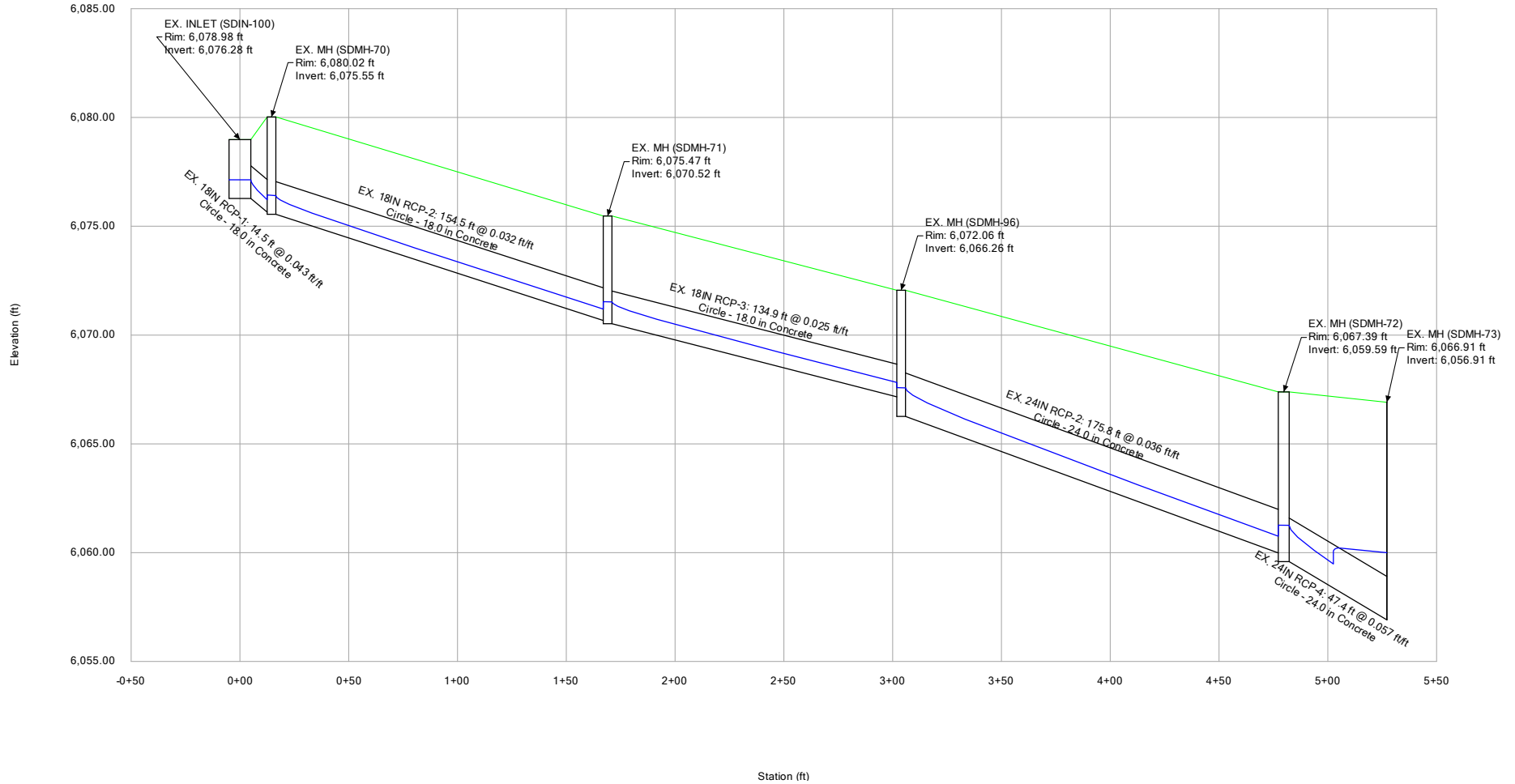

**5-YR STORM EVENT**

| Label          | -Node- Upstream Downstream | Diameter (in) | Slope (Calculated) (ft/ft) | Flow (cfs) | Length (User Defined) (ft) | Velocity (ft/s) | -EGL- Upstream Downstream (ft) | -Ground- Upstream Downstream (ft) | -HGL- Upstream Downstream (ft) | -Invert- Upstream Downstream (ft) | Section Discharge Capacity (cfs) | Capacity (Design) (cfs) |
|----------------|----------------------------|---------------|----------------------------|------------|----------------------------|-----------------|--------------------------------|-----------------------------------|--------------------------------|-----------------------------------|----------------------------------|-------------------------|
| CO-2           | INLET 2                    | 18            | -0.026                     | 1.04       | 43.9                       | 5.34            | 6069.84                        | 6075.9                            | 6072.32                        | 6068.94                           | 1.04                             | 17.07                   |
|                | INLET 1                    |               |                            |            |                            |                 | 6072.91                        | 6076.8                            | 6071.03                        | 6071.94                           | 17.07                            |                         |
| CO-3           | INLET 1                    | 12            | -0.027                     | 0.84       | 28.1                       | 6.38            | 6072.46                        | 6076.8                            | 6074.08                        | 6071.94                           | 0.84                             | 7.62                    |
|                | STM MH-1                   |               |                            |            |                            |                 | 6074.15                        | 6078.4                            | 6073.17                        | 6073.7                            | 7.62                             |                         |
| CO-4           | STM MH-1                   | 8             | -0.019                     | 0.49       | 123                        | 5.02            | 6074.23                        | 6078.4                            | 6076.57                        | 6073.7                            | 0.49                             | 2.17                    |
|                | CANOPY ROOF DRAIN          |               |                            |            |                            |                 | 6076.7                         | 6079.2                            | 6074.12                        | 6076.24                           | 2.17                             |                         |
| CO-7           | TRENCH DRAIN               | 8             | 0.023                      | 0.41       | 255                        | 5.13            | 6080.05                        | 6080.3                            | 6079.94                        | 6079.64                           | 0.41                             | 2.4                     |
|                | STM MH-1                   |               |                            |            |                            |                 | 6074.15                        | 6078.4                            | 6074.09                        | 6073.7                            | 2.4                              |                         |
| EX. 18IN RCP-4 | EX. INLET (SDIN-101)       | 18            | 0.029                      | 6.6        | 14.6                       | 9.33            | 6069.01                        | 6071.82                           | 6068.57                        | 6067.58                           | 6.6                              | 17.82                   |
|                | EX. MH (SDMH-96)           |               |                            |            |                            |                 | 6068.81                        | 6072.06                           | 6067.89                        | 6066.26                           | 17.82                            |                         |
| EX. 24IN RCP-2 | EX. MH (SDMH-96)           | 24            | 0.036                      | 13.34      | 175.8                      | 12.02           | 6068.15                        | 6072.06                           | 6067.57                        | 6066.26                           | 13.34                            | 42.72                   |
|                | EX. MH (SDMH-72)           |               |                            |            |                            |                 | 6063.51                        | 6067.39                           | 6060.76                        | 6059.59                           | 42.72                            |                         |
| EX. 24IN RCP-4 | EX. MH (SDMH-72)           | 24            | 0.057                      | 21.78      | 47.4                       | 16.22           | 6062.2                         | 6067.39                           | 6061.26                        | 6059.59                           | 21.78                            | 53.79                   |
|                | EX. MH (SDMH-73)           |               |                            |            |                            |                 | (N/A)                          | 6066.91                           | 6060                           | 6056.91                           | 53.79                            |                         |
| EX. 24IN RCP-1 | EX. INLET (SDIN-102)       | 24            | 0.03                       | 1.8        | 14.9                       | 6.35            | 6071.71                        | 6075.56                           | 6071.54                        | 6071.08                           | 1.8                              | 39.31                   |
|                | EX. MH (SDMH-71)           |               |                            |            |                            |                 | 6071.56                        | 6075.47                           | 6071.53                        | 6070.52                           | 39.31                            |                         |
| EX. 18IN RCP-3 | EX. MH (SDMH-71)           | 18            | 0.025                      | 6.74       | 134.9                      | 8.89            | 6071.97                        | 6075.47                           | 6071.52                        | 6070.52                           | 6.74                             | 16.58                   |
|                | EX. MH (SDMH-96)           |               |                            |            |                            |                 | 6068.81                        | 6072.06                           | 6067.83                        | 6066.26                           | 16.58                            |                         |
| EX. 18IN RCP-1 | EX. INLET (SDIN-100)       | 18            | 0.043                      | 4.94       | 14.5                       | 10.01           | 6077.49                        | 6078.98                           | 6077.13                        | 6076.28                           | 4.94                             | 21.89                   |
|                | EX. MH (SDMH-70)           |               |                            |            |                            |                 | 6077.46                        | 6080.02                           | 6076.21                        | 6075.55                           | 21.89                            |                         |
| EX. 18IN RCP-2 | EX. MH (SDMH-70)           | 18            | 0.032                      | 4.94       | 154.5                      | 8.92            | 6076.76                        | 6080.02                           | 6076.4                         | 6075.55                           | 4.94                             | 18.67                   |
|                | EX. MH (SDMH-71)           |               |                            |            |                            |                 | 6071.56                        | 6075.47                           | 6071.53                        | 6070.52                           | 18.67                            |                         |
| EX. 24IN RCP-3 | EX. MH (SDMH-72)           | 24            | -0.112                     | 1          | 14.5                       | 8.43            | 6062.2                         | 6067.39                           | 6061.56                        | 6059.59                           | 1                                | 75.84                   |
|                | EX. INLET (SDIN-53)        |               |                            |            |                            |                 | 6061.68                        | 6067.52                           | 6061.26                        | 6061.22                           | 75.84                            |                         |
| CO-20          | INLET 2                    | 18            | 0.05                       | 2.94       | 139                        | 9.07            | 6069.84                        | 6075.9                            | 6069.59                        | 6068.94                           | 2.94                             | 23.47                   |
|                | EX. INLET (SDIN-52)        |               |                            |            |                            |                 | 6063.67                        | 6067.97                           | 6062.36                        | 6061.41                           | 23.47                            |                         |
| EX. 24IN RCP-3 | EX. INLET (SDIN-52)        | 24            | 0.057                      | 7.44       | 14.5                       | 12.03           | 6062.76                        | 6067.97                           | 6062.38                        | 6061.41                           | 7.44                             | 53.79                   |
|                | EX. MH (SDMH-72)           |               |                            |            |                            |                 | 6063.51                        | 6067.39                           | 6061.2                         | 6059.59                           | 53.79                            |                         |

100-YEAR STORM EVENT

### Profile Report

## Engineering Profile - Profile - 1 (2293\_Parker\_Storm CAD - Updated.stsw)

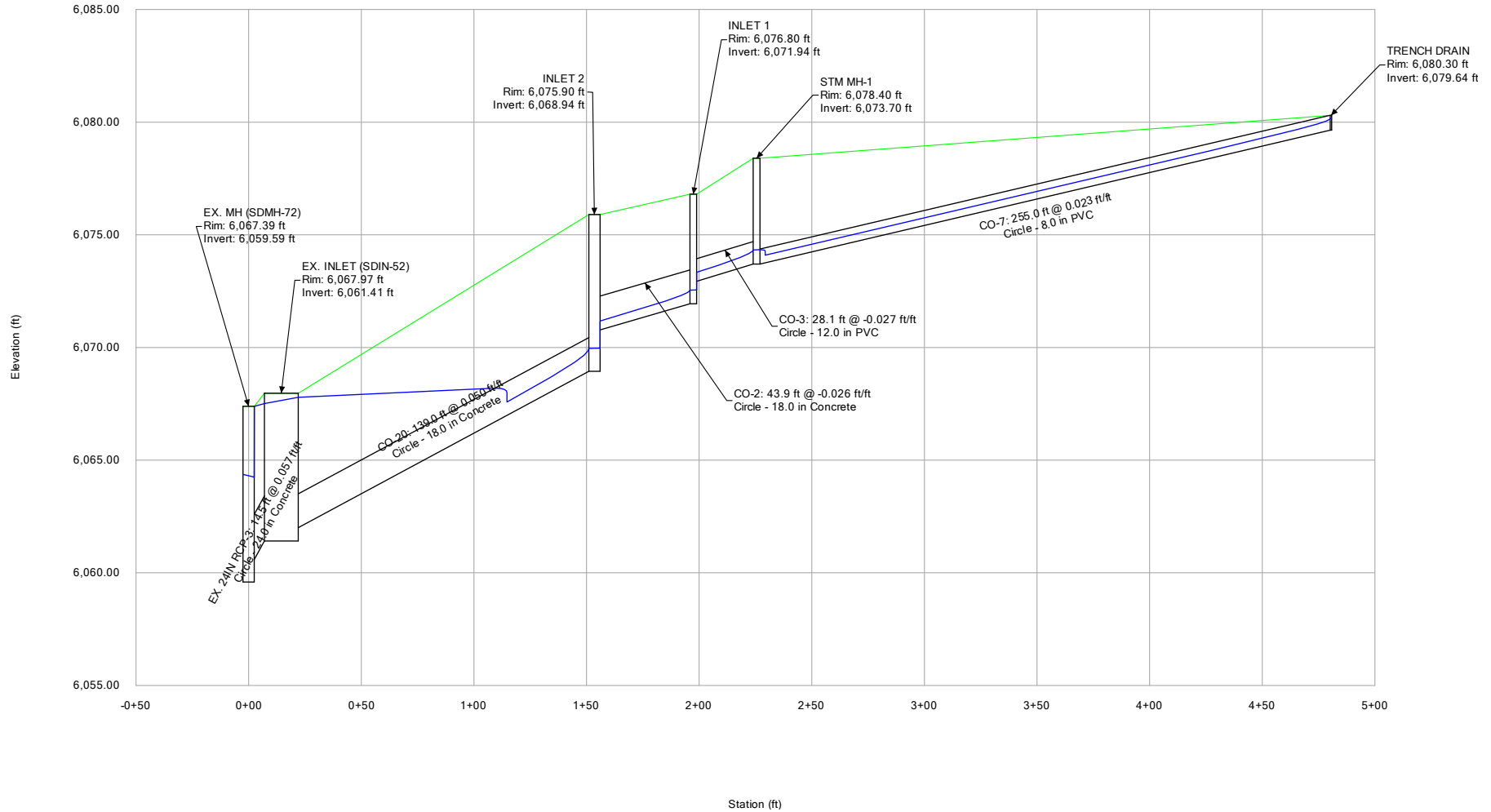

100-YEAR STORM EVENT

### Profile Report

#### Engineering Profile - Profile - 2 (2293\_Parker\_Storm CAD - Updated.stsw)

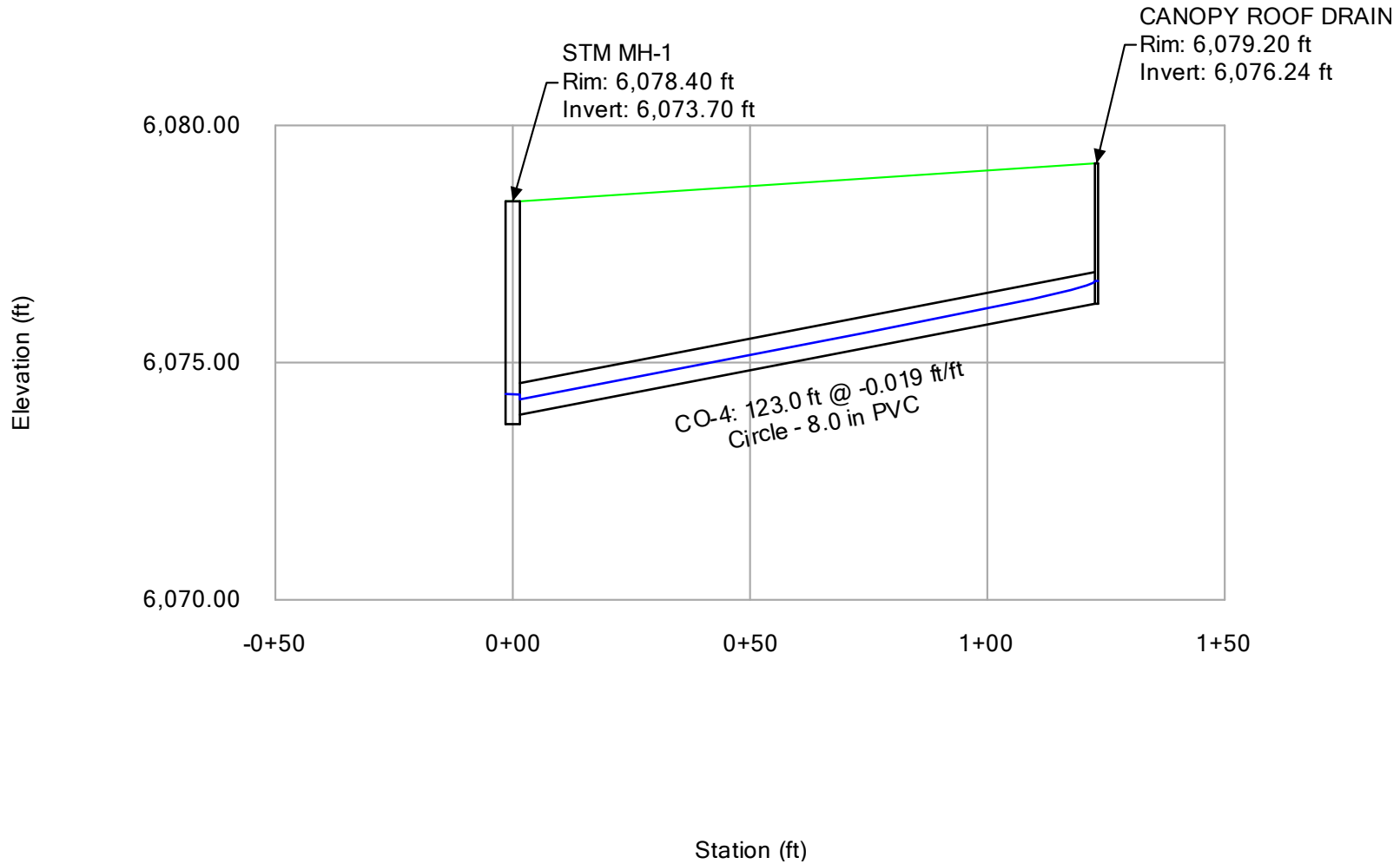

**100-YEAR STORM EVENT**

| Label          | -Node- Upstream Downstream | Diameter (in) | Slope (Calculated) (ft/ft) | Flow (cfs) | Length (User Defined) (ft) | Velocity (ft/s) | -EGL- Upstream Downstream (ft) | -Ground- Upstream Downstream (ft) | -HGL- Upstream Downstream (ft) | -Invert- Upstream Downstream (ft) | Section Discharge Capacity (cfs) | Capacity (Design) (cfs) |
|----------------|----------------------------|---------------|----------------------------|------------|----------------------------|-----------------|--------------------------------|-----------------------------------|--------------------------------|-----------------------------------|----------------------------------|-------------------------|
| CO-2           | INLET 2                    | 18            | -0.026                     | 2.55       | 43.9                       | 6.94            | 6070.41                        | 6075.9                            | 6072.54                        | 6068.94                           | 2.55                             | 17.07                   |
|                | INLET 1                    |               |                            |            |                            |                 | 6073.42                        | 6076.8                            | 6071.17                        | 6071.94                           | 17.07                            |                         |
| CO-3           | INLET 1                    | 12            | -0.027                     | 2.15       | 28.1                       | 8.33            | 6072.77                        | 6076.8                            | 6074.33                        | 6071.94                           | 2.15                             | 7.62                    |
|                | STM MH-1                   |               |                            |            |                            |                 | 6074.92                        | 6078.4                            | 6073.33                        | 6073.7                            | 7.62                             |                         |
| CO-4           | STM MH-1                   | 8             | -0.019                     | 1.03       | 123                        | 6.13            | 6074.59                        | 6078.4                            | 6076.72                        | 6073.7                            | 1.03                             | 2.17                    |
|                | CANOPY ROOF DRAIN          |               |                            |            |                            |                 | 6076.95                        | 6079.2                            | 6074.22                        | 6076.24                           | 2.17                             |                         |
| CO-7           | TRENCH DRAIN               | 8             | 0.023                      | 1.23       | 255                        | 6.91            | 6080.44                        | 6080.3                            | 6080.17                        | 6079.64                           | 1.23                             | 2.4                     |
|                | STM MH-1                   |               |                            |            |                            |                 | 6074.92                        | 6078.4                            | 6074.34                        | 6073.7                            | 2.4                              |                         |
| EX. 18IN RCP-4 | EX. INLET (SDIN-101)       | 18            | 0.029                      | 15.4       | 14.6                       | 8.71            | 6070.42                        | 6071.82                           | 6069.24                        | 6067.58                           | 15.4                             | 17.82                   |
|                | EX. MH (SDMH-96)           |               |                            |            |                            |                 | 6070.9                         | 6072.06                           | 6068.92                        | 6066.26                           | 17.82                            |                         |
| EX. 24IN RCP-2 | EX. MH (SDMH-96)           | 24            | 0.036                      | 36.79      | 175.8                      | 11.71           | 6070.69                        | 6072.06                           | 6068.56                        | 6066.26                           | 36.79                            | 42.72                   |
|                | EX. MH (SDMH-72)           |               |                            |            |                            |                 | 6063.32                        | 6067.39                           | 6063.91                        | 6059.59                           | 42.72                            |                         |
| EX. 24IN RCP-4 | EX. MH (SDMH-72)           | 24            | 0.057                      | 59.19      | 47.4                       | 18.84           | 6068.76                        | 6067.39                           | 6063.25                        | 6059.59                           | 59.19                            | 53.79                   |
|                | EX. MH (SDMH-73)           |               |                            |            |                            |                 | (N/A)                          | 6066.91                           | 6060                           | 6056.91                           | 53.79                            |                         |
| EX. 24IN RCP-1 | EX. INLET (SDIN-102)       | 24            | 0.03                       | 9.8        | 14.9                       | 3.12            | 6075.23                        | 6075.56                           | 6075.08                        | 6071.08                           | 9.8                              | 39.31                   |
|                | EX. MH (SDMH-71)           |               |                            |            |                            |                 | 6075.48                        | 6075.47                           | 6075.05                        | 6070.52                           | 39.31                            |                         |
| EX. 18IN RCP-3 | EX. MH (SDMH-71)           | 18            | 0.025                      | 21.39      | 134.9                      | 12.1            | 6076.52                        | 6075.47                           | 6074.24                        | 6070.52                           | 21.39                            | 16.58                   |
|                | EX. MH (SDMH-96)           |               |                            |            |                            |                 | 6070.9                         | 6072.06                           | 6068.64                        | 6066.26                           | 16.58                            |                         |
| EX. 18IN RCP-1 | EX. INLET (SDIN-100)       | 18            | 0.043                      | 11.59      | 14.5                       | 12.57           | 6078.37                        | 6078.98                           | 6077.58                        | 6076.28                           | 11.59                            | 21.89                   |
|                | EX. MH (SDMH-70)           |               |                            |            |                            |                 | 6078.44                        | 6080.02                           | 6076.6                         | 6075.55                           | 21.89                            |                         |
| EX. 18IN RCP-2 | EX. MH (SDMH-70)           | 18            | 0.032                      | 11.59      | 154.5                      | 11.13           | 6077.64                        | 6080.02                           | 6076.85                        | 6075.55                           | 11.59                            | 18.67                   |
|                | EX. MH (SDMH-71)           |               |                            |            |                            |                 | 6075.48                        | 6075.47                           | 6074.81                        | 6070.52                           | 18.67                            |                         |
| EX. 24IN RCP-3 | EX. MH (SDMH-72)           | 24            | -0.112                     | 2          | 14.5                       | 0.64            | 6068.76                        | 6067.39                           | 6063.32                        | 6059.59                           | 2                                | 75.84                   |
|                | EX. INLET (SDIN-53)        |               |                            |            |                            |                 | 6063.33                        | 6067.52                           | 6063.32                        | 6061.22                           | 75.84                            |                         |
| CO-20          | INLET 2                    | 18            | 0.05                       | 6.9        | 139                        | 11.55           | 6070.41                        | 6075.9                            | 6069.96                        | 6068.94                           | 6.9                              | 23.47                   |
|                | EX. INLET (SDIN-52)        |               |                            |            |                            |                 | 6066.65                        | 6067.97                           | 6066.41                        | 6061.41                           | 23.47                            |                         |
| EX. 24IN RCP-3 | EX. INLET (SDIN-52)        | 24            | 0.057                      | 20.4       | 14.5                       | 6.49            | 6066.89                        | 6067.97                           | 6066.23                        | 6061.41                           | 20.4                             | 53.79                   |
|                | EX. MH (SDMH-72)           |               |                            |            |                            |                 | 6063.32                        | 6067.39                           | 6066.11                        | 6059.59                           | 53.79                            |                         |

**APPENDIX D**  
**Master Drainage Report & Amendment Excerpts**



10333 E Dry Creek Road, Ste 240  
Englewood, Colorado 80112  
www.cvlci.com

720.482.9526

## **TRAILS AT CROWFOOT FINAL DRAINAGE REPORT**

Prepared for:  
E5X Management Inc  
Englewood, CO 80112  
**Phone (303) -440-9111**  
**Contact: Chris Elliott**

Prepared by:  
CVL Consultants of Colorado, Inc.  
10333 E. Dry Creek Road, Suite 240  
Englewood, CO 80112  
**Phone (720) 482-9526**  
**Contact: Mark Scheurer, P.E.**

CVL PROJECT NO. 8130283701

**June 2018**  
**May 2018 (Revised)**  
**February 2018 (Revised)**  
**October 2017 (Revised)**

TRAILS AT CROWFOOT  
Town of Parker, Colorado

---



*This report for the Final design of **Trails at Crowfoot** was prepared by me or under my direct supervision in accordance with the provisions of the Town of Parker Storm Drainage and Enviromental Criteria Manual. I understand that the Town of Parker and its designated town authority do not and will not assume liability for drainage facilities designed by other.*

A handwritten signature in blue ink, appearing to read "Mark Scheurer".

---

Signature

---

48988

---

Colorado P.E. License No.

---

June 18,2018

---

Seal and Date



| POND C                                 |         |
|--|---------|
| Description                            |         |
| Drainage Area (ACRES)                  | 101.09  |
| Percent Impervious (%)                 | 44.49   |
| WQCV Volume (AC-FT)                    | 1.495   |
| EURV Volume (including WQCV) (AC-FT)   | 4.262   |
| EURV water surface (FT)                | 5975.55 |
| 100-YR Volume (including EURV) (AC-FT) | 8.444   |
| 100-YR water surface (FT)              | 5977.94 |
| Emergency Spillway Elevation (FT)      | 5978.15 |
| 100-YR Peak Inflow (CFS)               | 204.8   |
| 100-YR Peak Outflow (CFS)              | 106.5   |
| 100-YR Peak Allowable (CFS)            | 111.36  |

Pond C complies with CRS 37-92-602(8). The UD-Detention worksheet is included in the appendix.

**Pond D** is a maintenance eligible regional facility with a drainage area of 50.2 acres. The weighted average imperviousness for the area is 55.4%. The pond provides full spectrum detention per UDFCD requirements. The UD-Detention spreadsheet was utilized to determine the WQCV and EURV. The CUHP/SWMM with calculated allowable release rates was utilized to determine the 100-year volume. The outlet discharges to Cherry Creek and will comply with Cherry Creek Reservoir Control Regulations. The overflow for Pond D conveys the peak inflow of 97.3 cfs and discharges west to Cherry Creek.

The table below summarizes the major basins and percent impervious from the CUHP/SWMM analysis used in the pond design.

| POND D SWMM BASINS |      |        |          |
|--------------------|------|--------|----------|
| Design Point       | AREA | % IMP. | WEIGHTED |
| ID                 | AC   | %      | %        |
| D-1                | 20.7 | 48     | 20       |
| F-1                | 29.5 | 55     | 32       |
| TOTAL              | 50.2 | -      | 52       |

The table on the following page summarizes the Pond D design. Calculations for the design of Pond D are included in the appendix. The Pond D detailed design is shown in the construction drawings.

| POND D                                 |         |
|--|---------|
| Description                            |         |
| Drainage Area (ACRES)                  | 50.18   |
| Percent Impervious (%)                 | 51.42   |
| WQCV Volume (AC-FT)                    | 0.805   |
| EURV Volume (including WQCV) (AC-FT)   | 2.447   |
| EURV water surface (FT)                | 5991.2  |
| 100-YR Volume (including EURV) (AC-FT) | 4.475   |
| 100-YR water surface (FT)              | 5993.16 |
| Emergency Spillway Elevation (FT)      | 5993.48 |
| 100-YR Peak Inflow (CFS)               | 97.3    |
| 100-YR Peak Outflow (CFS)              | 52.2    |
| 100-YR Peak Allowable (CFS)            | 55.28   |

Pond D complies with CRS 37-92-602(8). The UD-Detention worksheet is included in the appendix.

The minor sub-basins are described in detail as follows. These basins were delineated for the Rational Method analysis used in the street capacity, inlet, and stormsewer design.

Sub-basin A1 primarily consists of the lots along Red Cosmos Terr. Surface runoff generally drains to the curb and gutter, which continues northerly to the on-grade inlet at Design Point 1A where it is piped to DP 1. 100-year storm street flows to sump inlet DP 1B. Emergency flow from DP 1B will overland to Crowfoot Gulch.

Sub-basin A2 primarily consists of the lots along Rose Mallow Street. Surface runoff generally drains to the curb and gutter to sump inlet at Design Point 1B where it is piped Crowfoot Gulch via swale. Emergency flow from DP 1B will overland to Crowfoot Gulch.

Sub-basin A3 primarily consists of the lots along Rose Mallow Street. Surface runoff generally drains to the curb and gutter to sump inlet at Design Point 1C where it is piped Crowfoot Gulch via swale. Emergency flow from DP 1C will overland to Crowfoot Gulch.

Sub-basin A4 primarily consists of the lots along Wild Lupine Street and Shasta Daisy Street. Surface runoff generally drains to the curb and gutter to sump inlet at Design Point 1D where it is piped Crowfoot Gulch via swale. Emergency flow from DP 1D will overland to Crowfoot Gulch.

Sub-basin A5 primarily consists of the lots along Shasta Daisy Street and Scarlet Sage Ave. Surface runoff generally drains to the curb and gutter to sump inlet at Design Point 1E where it is piped Crowfoot Gulch via swale. Emergency flow from DP 1E will overland to Crowfoot Gulch.

Sub-basin A6 primarily consists of the lots along Scarlet Sage Ln. Surface runoff generally drains to the curb and gutter, which continues westerly to the on-grade inlet at Design Point

Sub-basin F1 is located along Alpine Phlox Street and N. Pinery Parkway. Surface runoff generally drains to on-grade inlet at Design Point 6A. 100 Year discharge from 6A street flows to sump inlet at Design Point 6I. Emergency flow from DP 6I overland flows to Pond D.

Sub-basin F2 is located along Alpine Phlox Street. Surface runoff generally drains to on-grade inlet at Design Point 6B. 100 Year discharge from 6B street flows to sump inlet at Design Point 6I. Emergency flow from DP 6I overland flows to Pond D.

Sub-basin F3 is located along Scarlet Sage Ave and Sky Pilot Ave. Surface runoff generally drains to on-grade inlet at Design Point 6C. 100 Year discharge from 6C street flows to sump inlet at Design Point 6I. Emergency flow from DP 6I overland flows to Pond D.

Sub-basin F4 primarily consists of lots located along Sky Pilot Ave. Surface runoff generally drains to Design Point 6D. 2 Year discharge from 6D street flows Design Point 6C. 100 Year discharge from 6D street flows to sump inlet at Design Point 6I. Emergency flow from DP 6I overland flows to Pond D.

Sub-basin F5 primarily consists of lots located along N. Pinery Parkway. Surface runoff generally drains to on-grade inlet at Design Point 6E. 100 Year discharge from 6E street flows to sump inlet at Design Point 6I. Emergency flow from DP 6I overland flows to Pond D.

Sub-basin F6 primarily consists of lots located along Beebalm Way. Surface runoff generally drains to sump inlet at Design Point 6F. Emergency flow from DP 6F overland flows to Pond C.

Sub-basin F7 is located along N. Pinery Parkway. Surface runoff generally drains to sump inlet at Design Point 6G. Emergency flow from DP 6G overland flows to Pond D.

Sub-basin F8 primarily consists of lots located along Beebalm Way. Surface runoff generally drains to sump inlet at Design Point 6H. Emergency flow from DP 6H overland flows to Pond C.

Sub-basin F9 is located along street E and N. Pinery Parkway. Surface runoff generally drains to sump inlet at Design Point 6I. Emergency flow from DP 6I overland flows to Pond D.

Sub-basin F10 is located along Alpine Phlox Street. Surface runoff generally drains to on-grade inlet at Design Point 6J. 100 Year discharge from 6J street flows to sump inlet at Design Point 6I. Emergency flow from DP 6I overland flows to Pond D.

Sub-basin F11 is located along Alpine Phlox Street. Surface runoff generally drains to on-grade inlet at Design Point 6K. 100 Year discharge from 6K street flows to sump inlet at Design Point 6I. Emergency flow from DP 6I overland flows to Pond D.

Sub-basin F12 is located along Alpine Phlox Street. Surface runoff generally drains to on-grade inlet at Design Point 6L. 100 Year discharge from 6L street flows to sump inlet at Design Point 6I. Emergency flow from DP 6I overland flows to Pond D.

Sub-basin F13 primarily consists of lots located along Sky Pilot Lane. Surface runoff generally drains to Design Point 6M. 2 Year discharge from 6M street flows Design Point 6C. 100 Year discharge from 6M street flows to sump inlet at Design Point 6I. Emergency flow from DP 6I overland flows to Pond D.

| Note:                             |      |                |       |       |             |       |
|-----------------------------------|------|----------------|-------|-------|-------------|-------|
| 1) 0% slope indicates sump inlet. |      |                |       |       |             |       |
| DIRECT FLOW                       |      |                |       |       |             |       |
| BASIN ID                          | AREA | Imperviousness | Q2    | Q100  | Street Type | Slope |
|                                   | (AC) | %              | (CFS) | (CFS) |             | %     |
| F1                                | 1.71 | 90.64          | 4.59  | 13.55 | Local       | 2.50  |
| F2                                | 1.77 | 93.50          | 4.96  | 14.53 | Local       | 2.50  |
| F3                                | 3.60 | 19.77          | 1.47  | 12.47 | Local       | 1.00  |
| F4                                | 3.79 | 53.06          | 4.56  | 18.47 | Local       | 4.00  |
| F5                                | 4.58 | 46.86          | 4.46  | 19.66 | Res. Blvd   | 4.00  |
| F6                                | 4.93 | 38.37          | 3.70  | 18.75 | Local       | 0.00  |
| F7                                | 4.51 | 18.05          | 1.68  | 15.41 | Res. Blvd   | 0.00  |
| F8                                | 7.93 | 34.99          | 5.57  | 30.18 | Local       | 0.00  |
| F9                                | 1.28 | 66.27          | 1.75  | 6.18  | Res. Blvd   | 0.00  |
| F10                               | 1.93 | 92.20          | 5.30  | 15.64 | Local       | 2.50  |
| F11                               | 1.50 | 91.79          | 4.07  | 12.03 | Local       | 2.50  |
| F12                               | 1.22 | 93.17          | 3.39  | 9.95  | Local       | 2.50  |
| F13                               | 3.58 | 52.91          | 4.36  | 17.70 | Local       | 4.00  |

Sub-basin OS10 is located in the South west of the site. Surface runoff will overland flow to DP 34. Flow from DP 34 is conveyed to the Crowfoot Gulch via DP A.

| DIRECT FLOW |      |                |       |       |             |       |
|-------------|------|----------------|-------|-------|-------------|-------|
| BASIN ID    | AREA | Imperviousness | Q2    | Q100  | Street Type | Slope |
|             | (AC) | %              | (CFS) | (CFS) |             | %     |
| OS 10       | 5.37 | 2.00           | 0.30  | 16.40 | N/A         | 5.00  |

Sub-basin OS 1 is located south west of the site. Surface runoff overland flows to Design Point A. Flow from DP A and is conveyed via pipe into the Crowfoot Gulch. This point was evaluated in the SWMM model. The Q100 peak flow for OS 1 is 19 cfs.

Sub-basin OS 2 is located south west of the site. . Surface runoff overland flows to the Crowfoot Gulch. This point was evaluated in the SWMM model. The Q100 peak flow for OS 2 is 9.06 cfs.

Sub-basin OS 8 is located south west of the site. . Surface runoff overland flows to the Crowfoot Gulch. This point was evaluated in the SWMM model. The Q100 peak flow for OS 8 is 8.04 cfs.

F1

| Total Area                  |      | 1.73 acres     |                |                  | Composite Calculations |             |                |                |                  |
|-----------------------------|------|----------------|----------------|------------------|------------------------|-------------|----------------|----------------|------------------|
| Land Use                    | Imp. | C <sub>2</sub> | C <sub>5</sub> | C <sub>100</sub> | Area                   | Imp%        | C <sub>2</sub> | C <sub>5</sub> | C <sub>100</sub> |
| Residential (Single Family) | 45%  | 0.40           | 0.43           | 0.69             | 0.00                   | 0.0         | 0.00           | 0.00           | 0.00             |
| Business                    | 95%  | 0.85           | 0.88           | 0.94             | 1.42                   | 77.9        | 0.70           | 0.72           | 0.77             |
| Residential (Multi Family)  | 75%  | 0.67           | 0.70           | 0.84             | 0.00                   | 0.0         | 0.00           | 0.00           | 0.00             |
| ROW                         | 77%  | 0.68           | 0.72           | 0.84             | 0.29                   | 12.7        | 0.11           | 0.12           | 0.14             |
| Open Space / Lawns          | 2%   | 0.02           | 0.05           | 0.49             | 0.00                   | 0.0         | 0.00           | 0.00           | 0.00             |
| <b>TOTAL</b>                |      |                |                |                  | <b>1.71</b>            | <b>90.6</b> | <b>0.81</b>    | <b>0.84</b>    | <b>0.91</b>      |

F2

| Total Area                  |      | 1.77 acres     |                |                  | Composite Calculations |             |                |                |                  |
|-----------------------------|------|----------------|----------------|------------------|------------------------|-------------|----------------|----------------|------------------|
| Land Use                    | Imp. | C <sub>2</sub> | C <sub>5</sub> | C <sub>100</sub> | Area                   | Imp%        | C <sub>2</sub> | C <sub>5</sub> | C <sub>100</sub> |
| Residential (Single Family) | 45%  | 0.40           | 0.43           | 0.69             | 0.00                   | 0.0         | 0.00           | 0.00           | 0.00             |
| Business                    | 95%  | 0.85           | 0.88           | 0.94             | 1.65                   | 88.3        | 0.79           | 0.82           | 0.87             |
| Residential (Multi Family)  | 75%  | 0.67           | 0.70           | 0.84             | 0.00                   | 0.0         | 0.00           | 0.00           | 0.00             |
| ROW                         | 74%  | 0.66           | 0.69           | 0.83             | 0.12                   | 5.2         | 0.05           | 0.05           | 0.06             |
| Open Space / Lawns          | 2%   | 0.02           | 0.05           | 0.49             | 0.00                   | 0.0         | 0.00           | 0.00           | 0.00             |
| <b>TOTAL</b>                |      |                |                |                  | <b>1.77</b>            | <b>93.5</b> | <b>0.84</b>    | <b>0.87</b>    | <b>0.93</b>      |

F3

| Total Area                  |      | 3.60 acres     |                |                  | Composite Calculations |             |                |                |                  |
|-----------------------------|------|----------------|----------------|------------------|------------------------|-------------|----------------|----------------|------------------|
| Land Use                    | Imp. | C <sub>2</sub> | C <sub>5</sub> | C <sub>100</sub> | Area                   | Imp%        | C <sub>2</sub> | C <sub>5</sub> | C <sub>100</sub> |
| Residential (Single Family) | 45%  | 0.40           | 0.43           | 0.69             | 0.00                   | 0.0         | 0.00           | 0.00           | 0.00             |
| Business                    | 95%  | 0.85           | 0.88           | 0.94             | 0.00                   | 0.0         | 0.00           | 0.00           | 0.00             |
| Residential (Multi Family)  | 75%  | 0.67           | 0.70           | 0.84             | 0.00                   | 0.0         | 0.00           | 0.00           | 0.00             |
| ROW                         | 74%  | 0.66           | 0.69           | 0.83             | 0.89                   | 18.3        | 0.16           | 0.17           | 0.21             |
| Open Space / Lawns          | 2%   | 0.02           | 0.05           | 0.49             | 2.70                   | 1.5         | 0.02           | 0.03           | 0.37             |
| <b>TOTAL</b>                |      |                |                |                  | <b>3.60</b>            | <b>19.8</b> | <b>0.18</b>    | <b>0.20</b>    | <b>0.57</b>      |

F4

| Total Area                  |      | 3.79 acres     |                |                  | Composite Calculations |             |                |                |                  |
|-----------------------------|------|----------------|----------------|------------------|------------------------|-------------|----------------|----------------|------------------|
| Land Use                    | Imp. | C <sub>2</sub> | C <sub>5</sub> | C <sub>100</sub> | Area                   | Imp%        | C <sub>2</sub> | C <sub>5</sub> | C <sub>100</sub> |
| Residential (Single Family) | 45%  | 0.40           | 0.43           | 0.69             | 2.57                   | 30.6        | 0.27           | 0.29           | 0.47             |
| Business                    | 95%  | 0.85           | 0.88           | 0.94             | 0.00                   | 0.0         | 0.00           | 0.00           | 0.00             |
| Residential (Multi Family)  | 75%  | 0.67           | 0.70           | 0.84             | 0.00                   | 0.0         | 0.00           | 0.00           | 0.00             |
| ROW                         | 74%  | 0.66           | 0.69           | 0.83             | 1.15                   | 22.4        | 0.20           | 0.21           | 0.25             |
| Open Space / Lawns          | 2%   | 0.02           | 0.05           | 0.49             | 0.06                   | 0.0         | 0.00           | 0.00           | 0.01             |
| <b>TOTAL</b>                |      |                |                |                  | <b>3.79</b>            | <b>53.1</b> | <b>0.47</b>    | <b>0.50</b>    | <b>0.73</b>      |

F5

| Total Area                  |      | 4.58 acres     |                |                  | Composite Calculations |             |                |                |                  |
|-----------------------------|------|----------------|----------------|------------------|------------------------|-------------|----------------|----------------|------------------|
| Land Use                    | Imp. | C <sub>2</sub> | C <sub>5</sub> | C <sub>100</sub> | Area                   | Imp%        | C <sub>2</sub> | C <sub>5</sub> | C <sub>100</sub> |
| Residential (Single Family) | 45%  | 0.40           | 0.43           | 0.69             | 2.18                   | 21.4        | 0.19           | 0.20           | 0.33             |
| Business                    | 95%  | 0.85           | 0.88           | 0.94             | 0.00                   | 0.0         | 0.00           | 0.00           | 0.00             |
| Residential (Multi Family)  | 75%  | 0.67           | 0.70           | 0.84             | 0.00                   | 0.0         | 0.00           | 0.00           | 0.00             |
| ROW                         | 77%  | 0.68           | 0.72           | 0.84             | 1.49                   | 25.1        | 0.22           | 0.23           | 0.27             |
| Open Space / Lawns          | 2%   | 0.02           | 0.05           | 0.49             | 0.90                   | 0.4         | 0.00           | 0.01           | 0.10             |
| <b>TOTAL</b>                |      |                |                |                  | <b>4.58</b>            | <b>46.9</b> | <b>0.42</b>    | <b>0.45</b>    | <b>0.70</b>      |

F10

**Total Area**

**1.93 acres**

Composite Calculations

| Land Use                    | Imp. | C <sub>2</sub> | C <sub>5</sub> | C <sub>100</sub> | Area        | Imp%        | C <sub>2</sub> | C <sub>5</sub> | C <sub>100</sub> |
|-----------------------------|------|----------------|----------------|------------------|-------------|-------------|----------------|----------------|------------------|
| Residential (Single Family) | 45%  | 0.40           | 0.43           | 0.69             | 0.00        | 0.0         | 0.00           | 0.00           | 0.00             |
| Business                    | 95%  | 0.85           | 0.88           | 0.94             | 1.61        | 79.2        | 0.71           | 0.73           | 0.78             |
| Residential (Multi Family)  | 75%  | 0.67           | 0.70           | 0.84             | 0.00        | 0.0         | 0.00           | 0.00           | 0.00             |
| ROW                         | 77%  | 0.68           | 0.72           | 0.84             | 0.33        | 12.9        | 0.12           | 0.12           | 0.14             |
| Open Space / Lawns          | 2%   | 0.02           | 0.05           | 0.49             | 0.00        | 0.0         | 0.00           | 0.00           | 0.00             |
| <b>TOTAL</b>                |      |                |                |                  | <b>1.93</b> | <b>92.2</b> | <b>0.82</b>    | <b>0.85</b>    | <b>0.93</b>      |

F11

**Total Area**

**1.50 acres**

Composite Calculations

| Land Use                    | Imp. | C <sub>2</sub> | C <sub>5</sub> | C <sub>100</sub> | Area        | Imp%        | C <sub>2</sub> | C <sub>5</sub> | C <sub>100</sub> |
|-----------------------------|------|----------------|----------------|------------------|-------------|-------------|----------------|----------------|------------------|
| Residential (Single Family) | 45%  | 0.40           | 0.43           | 0.69             | 0.00        | 0.0         | 0.00           | 0.00           | 0.00             |
| Business                    | 95%  | 0.85           | 0.88           | 0.94             | 1.24        | 78.3        | 0.70           | 0.73           | 0.78             |
| Residential (Multi Family)  | 75%  | 0.67           | 0.70           | 0.84             | 0.00        | 0.0         | 0.00           | 0.00           | 0.00             |
| ROW                         | 77%  | 0.68           | 0.72           | 0.84             | 0.26        | 13.5        | 0.12           | 0.13           | 0.15             |
| Open Space / Lawns          | 2%   | 0.02           | 0.05           | 0.49             | 0.00        | 0.0         | 0.00           | 0.00           | 0.00             |
| <b>TOTAL</b>                |      |                |                |                  | <b>1.50</b> | <b>91.8</b> | <b>0.82</b>    | <b>0.85</b>    | <b>0.92</b>      |

F12

**Total Area**

**1.22 acres**

Composite Calculations

| Land Use                    | Imp. | C <sub>2</sub> | C <sub>5</sub> | C <sub>100</sub> | Area        | Imp%        | C <sub>2</sub> | C <sub>5</sub> | C <sub>100</sub> |
|-----------------------------|------|----------------|----------------|------------------|-------------|-------------|----------------|----------------|------------------|
| Residential (Single Family) | 45%  | 0.40           | 0.43           | 0.69             | 0.00        | 0.0         | 0.00           | 0.00           | 0.00             |
| Business                    | 95%  | 0.85           | 0.88           | 0.94             | 1.11        | 86.9        | 0.78           | 0.80           | 0.86             |
| Residential (Multi Family)  | 75%  | 0.67           | 0.70           | 0.84             | 0.00        | 0.0         | 0.00           | 0.00           | 0.00             |
| ROW                         | 74%  | 0.66           | 0.69           | 0.83             | 0.10        | 6.3         | 0.06           | 0.06           | 0.07             |
| Open Space / Lawns          | 2%   | 0.02           | 0.05           | 0.49             | 0.00        | 0.0         | 0.00           | 0.00           | 0.00             |
| <b>TOTAL</b>                |      |                |                |                  | <b>1.22</b> | <b>93.2</b> | <b>0.83</b>    | <b>0.86</b>    | <b>0.93</b>      |

## STANDARD FORM SF-2 TIME OF CONCENTRATION

Subdivision: Trails at Crowfoot

Project Name: Trails at Crowfoot  
 Project No. 254103  
 Calculated By: MRS  
 Date: 1/31/2018

| SUB-BASIN DATA |           |                | INITIAL/OVERLAND (T <sub>i</sub> ) |       |                      | TRAVEL TIME (T <sub>i</sub> ) |       |            |                      | T <sub>c</sub> CHECK (URBANIZED BASINS) |                  |                           | FINAL                |
|----------------|-----------|----------------|------------------------------------|-------|----------------------|-------------------------------|-------|------------|----------------------|---|------------------|---------------------------|----------------------|
| BASIN ID       | D.A. (AC) | C <sub>5</sub> | L (FT)                             | S (%) | T <sub>i</sub> (MIN) | L (FT)                        | S (%) | VEL. (FPS) | T <sub>i</sub> (MIN) | COMP. T <sub>c</sub> (MIN)              | TOTAL LENGTH(FT) | MIN. T <sub>c</sub> (MIN) | T <sub>c</sub> (MIN) |
| F1             | 1.71      | 0.84           | 50                                 | 1.0   | 3.3                  | 400                           | 3.0   | 3.5        | 1.9                  | 5.2                                     | 450.0            | 12.5                      | 5.2                  |
| F2             | 1.77      | 0.87           | 50                                 | 1.0   | 3.0                  | 510                           | 4.3   | 4.1        | 2.0                  | 5.0                                     | 560.0            | 13.1                      | 5.0                  |
| F3             | 3.60      | 0.20           | 50                                 | 1.0   | 11.4                 | 717                           | 1.3   | 2.2        | 5.5                  | 16.9                                    | 767.0            | 14.3                      | 14.3                 |
| F4             | 3.79      | 0.50           | 50                                 | 1.0   | 7.6                  | 850                           | 3.8   | 3.8        | 3.7                  | 11.3                                    | 900.0            | 15.0                      | 11.3                 |
| F5             | 4.58      | 0.45           | 50                                 | 1.0   | 8.3                  | 719                           | 1.3   | 2.2        | 5.5                  | 13.8                                    | 769.0            | 14.3                      | 13.8                 |
| F6             | 4.93      | 0.37           | 50                                 | 1.0   | 9.3                  | 1234                          | 2.6   | 3.2        | 6.5                  | 15.8                                    | 1284.0           | 17.1                      | 15.8                 |
| F7             | 4.51      | 0.19           | 50                                 | 1.0   | 11.6                 | 721                           | 1.2   | 2.2        | 5.5                  | 17.1                                    | 771.0            | 14.3                      | 14.3                 |
| F8             | 7.93      | 0.34           | 50                                 | 1.0   | 9.7                  | 1070                          | 2.8   | 3.3        | 5.3                  | 15.0                                    | 1120.0           | 16.2                      | 15.0                 |
| F9             | 1.28      | 0.62           | 50                                 | 1.0   | 6.1                  | 1708                          | 3.2   | 3.6        | 8.0                  | 14.0                                    | 1758.0           | 19.8                      | 14.0                 |
| F10            | 1.93      | 0.85           | 50                                 | 1.0   | 3.1                  | 520                           | 4.4   | 4.2        | 2.1                  | 5.2                                     | 570.0            | 13.2                      | 5.2                  |
| F11            | 1.50      | 0.85           | 50                                 | 1.0   | 3.2                  | 520                           | 4.0   | 4.0        | 2.2                  | 5.3                                     | 570.0            | 13.2                      | 5.3                  |
| F12            | 1.22      | 0.86           | 50                                 | 1.0   | 3.0                  | 510                           | 4.3   | 4.1        | 2.0                  | 5.1                                     | 560.0            | 13.1                      | 5.1                  |
| F13            | 3.58      | 0.50           | 50                                 | 1.0   | 7.6                  | 850                           | 4.7   | 4.3        | 3.3                  | 10.9                                    | 900.0            | 15.0                      | 10.9                 |
| OS1            | 56.02     | 0.05           | 300                                | 3.1   | 22.7                 | 2240                          | 5.5   | 4.7        | 8.0                  | 30.6                                    | 2540.0           | 24.1                      | 24.1                 |
| OS2            | 10.95     | 0.05           | 300                                | 1.2   | 30.8                 | 1334                          | 1.2   | 2.2        | 10.1                 | 40.9                                    | 1634.0           | 19.1                      | 19.1                 |
| OS3            | 5.32      | 0.05           | 300                                | 2.9   | 23.2                 | 1037                          | 2.9   | 3.3        | 5.2                  | 28.4                                    | 1337.0           | 17.4                      | 17.4                 |
| OS4            | 2.22      | 0.05           | 300                                | 3.5   | 21.7                 | 730                           | 3.5   | 3.7        | 3.3                  | 24.9                                    | 1030.0           | 15.7                      | 15.7                 |
| OS10           | 5.37      | 0.05           | 300                                | 4.2   | 20.4                 | 305                           | 4.2   | 4.1        | 1.2                  | 21.6                                    | 605.0            | 13.4                      | 13.4                 |

**NOTES:**

$$T_i = (1.8 * (1.1 - C_5) * (L)^{0.5}) / (S^{0.33})$$

$$T_i = L / 60V \text{ (Velocity From Fig. 3-2)}$$

$$T_c \text{ Check} = 10 + L / 180$$

**STANDARD FORM SF-3**  
**STORM DRAINAGE SYSTEM DESIGN**  
(RATIONAL METHOD PROCEDURE)

Subdivision Trails at Crowfoot

Project Name: Trails at Crowfoot  
Project No. 254103  
Calculated By: MRS  
Date: 4/9/2018

Design Storm 100 Yr  
100-Year P1 = 2.6 in.

| COMBINED BASINS          | DIRECT RUNOFF |              |           |               |          |                     |           |         | TOTAL RUNOFF              |               |                |          |                     | STREET    |         | PIPE      |                   |                   | TRAVEL TIME |                    |             | REMARKS |                |                           |  |
|--------------------------|---------------|--------------|-----------|---------------|----------|---------------------|-----------|---------|---------------------------|---------------|----------------|----------|---------------------|-----------|---------|-----------|-------------------|-------------------|-------------|--------------------|-------------|---------|----------------|---------------------------|--|
|                          | Design Point  | Area Design. | Area (Ac) | Runoff Coeff. | Tc (min) | C <sub>a</sub> (Ac) | i (in/hr) | Q (cfs) | Inlet Type                | Q (Intercept) | Q (Carry-Over) | Tc (min) | C <sub>a</sub> (Ac) | i (in/hr) | Q (cfs) | Slope (%) | Street Flow (cfs) | Design Flow (cfs) | Slope (%)   | Pipe Size (inches) | Length (ft) |         | Velocity (fps) | Tc (min)                  |  |
| F12                      | 6L            | F12          | 1.22      | 0.93          | 5.1      | 1.13                | 8.8       | 9.9     |                           |               |                | 5.1      | 1.13                | 8.8       | 9.9     |           |                   |                   |             |                    |             |         |                |                           |  |
| F2                       | 6B            | F2           | 1.77      | 0.93          | 5.0      | 1.65                | 8.8       | 14.5    |                           |               |                | 5.5      | 2.78                | 8.6       | 23.9    | 1.0       | 9.9               |                   |             |                    | 50.0        | 2.00    | 0.4            | Street Flow to 6B         |  |
| F2,11,12                 | 6K            | F11          | 1.50      | 0.92          | 5.3      | 1.39                | 8.7       | 12.0    |                           |               |                | 6.6      | 4.17                | 8.2       | 34.0    | 1.0       | 23.9              |                   |             |                    | 130.0       | 2.00    | 1.1            | Street Flow to 6K         |  |
| F2,10,11,12              | 6J            | F10          | 1.93      | 0.93          | 5.2      | 1.79                | 8.7       | 15.6    |                           |               |                | 7.4      | 5.96                | 7.9       | 46.8    | 1.0       | 34.0              |                   |             |                    | 100.0       | 2.00    | 0.8            | Street Flow to 6J         |  |
| F1,2,10,11,12            | 6A            | F1           | 1.71      | 0.91          | 5.2      | 1.55                | 8.7       | 13.5    |                           |               |                | 8.2      | 7.51                | 7.6       | 56.9    | 1.0       | 46.8              |                   |             |                    | 100.0       | 2.00    | 0.8            | Street Flow to 6A         |  |
| F1,2,10,11,12            | 16            |              |           |               |          |                     |           |         |                           |               |                | 8.9      | 7.51                | 7.4       | 55.3    | 1.0       | 56.9              |                   |             |                    | 80.0        | 2.00    | 0.7            | Street Flow to DP 16      |  |
| F4                       | 6D            | F4           | 3.79      | 0.73          | 11.3     | 2.76                | 6.7       | 18.5    |                           |               |                | 11.3     | 2.76                | 6.7       | 18.5    | 1.0       | 18.5              |                   |             |                    | 1025.0      | 2.00    | 8.5            | Street Flow to 6E         |  |
| F4,13                    | 6M            | F13          | 3.58      | 0.73          | 10.9     | 2.60                | 6.8       | 17.7    |                           |               |                | 11.7     | 5.36                | 6.6       | 35.4    | 1.0       | 35.4              |                   |             |                    | 50.0        | 2.00    | 0.4            | Street Flow to 6M         |  |
| F3,4,13                  | 6C            | F3           | 3.60      | 0.57          | 14.3     | 2.06                | 6.0       | 12.5    |                           |               |                | 14.3     | 7.42                | 6.0       | 44.9    | 1.0       | 44.9              |                   |             |                    | 200.0       | 2.00    | 1.7            | Street Flow to DP 17      |  |
| F1,2,5,10,11,12          | 6E            | F5           | 4.58      | 0.70          | 13.8     | 3.20                | 6.1       | 19.7    |                           |               |                | 17.4     | 10.72               | 5.5       | 58.8    | 1.0       | 58.8              |                   |             |                    | 100.0       | 2.00    | 0.8            | Street Flow to DP 17      |  |
| F1,2,3,4,5,10,11,12,13   | 17            |              |           |               |          |                     |           |         |                           |               |                | 18.3     | 18.14               | 5.4       | 97.2    | 5.0       | 97.2              |                   |             |                    | 952.0       | 4.47    | 3.5            | Street Flow to 6fa        |  |
| F1,2,3,4,5,10,11,12,13   | 6la           |              |           |               |          |                     |           |         |                           |               |                | 18.3     | 14.65               | 5.4       | 78.5    | 3.0       | 18.72             |                   |             |                    | 270.0       | 3.46    | 1.3            | Street Flow to 6l & 6G    |  |
| F7                       | 6G            | F7           | 4.51      | 0.57          | 14.3     | 2.55                | 6.0       | 15.4    | 1 @ 10" Type R Sump Inlet | 22.2          | 0.0            | 19.6     | 4.30                | 5.2       | 22.2    |           |                   | 78.5              | 0.50        | 48.00              | 100.0       | 9.10    | 0.2            | Piped to Pond D           |  |
| F1,2,3,4,5,9,10,11,12,13 | 6l            | F9           | 1.28      | 0.79          | 14.0     | 1.02                | 6.1       | 6.2     | 1 @ 10" Type R Sump Inlet | 15.5          | 0.0            | 19.7     | 7.06                | 5.2       | 36.4    |           |                   | 22.2              | 0.50        | 36.00              | 50.0        | 9.10    | 0.1            | Piped to 6l               |  |
| E13                      | 5M            | E13          | 4.45      | 0.62          | 14.2     | 2.76                | 6.0       | 16.7    |                           |               |                | 14.2     | 2.76                | 6.0       | 16.7    |           |                   | 36.4              | 0.50        | 36.00              | 100.0       | 9.10    | 0.2            | Piped to Pond D           |  |
| E17                      | 5Q            | E17          | 1.55      | 0.83          | 10.7     | 1.28                | 6.8       | 8.8     |                           |               |                | 14.8     | 4.04                | 5.9       | 24.0    | 1.0       | 16.7              |                   |             |                    | 70.0        | 2.00    | 0.6            | Street Flow to 5Q         |  |
| F8                       | 6H            | F8           | 7.93      | 0.64          | 15.0     | 5.11                | 5.9       | 30.2    | 1 @ 15" Type R Sump Inlet | 42.1          | 9.0            | 16.8     | 9.15                | 5.6       | 51.1    |           |                   | 24.0              | 0.50        | 30.00              | 780.0       | 6.60    | 2.0            | Piped/Overland Flow to 6H |  |
| F6                       | 6F            | F6           | 4.93      | 0.66          | 15.8     | 3.25                | 5.8       | 18.7    | 1 @ 10" Type R Sump Inlet | 27.8          | 0.0            | 16.9     | 12.40               | 5.6       | 69.2    |           |                   | 42.1              | 0.50        | 36.00              | 30.0        | 7.60    | 0.1            | Piped to 6F               |  |
|                          |               |              |           |               |          |                     |           |         |                           |               |                |          |                     |           |         |           |                   | 69.2              | 0.50        | 42.00              | 102.0       | 8.40    | 0.2            | Piped to Pond C           |  |

N:\PROJECTS\SS\BENCHMARKS\ENGINEERING\DRAINAGE\OVERALL\DRAINAGE\_MAP\DRNG\_ASR\DRNG\_ASR.DWG, 4/10/2018 8:23 AM

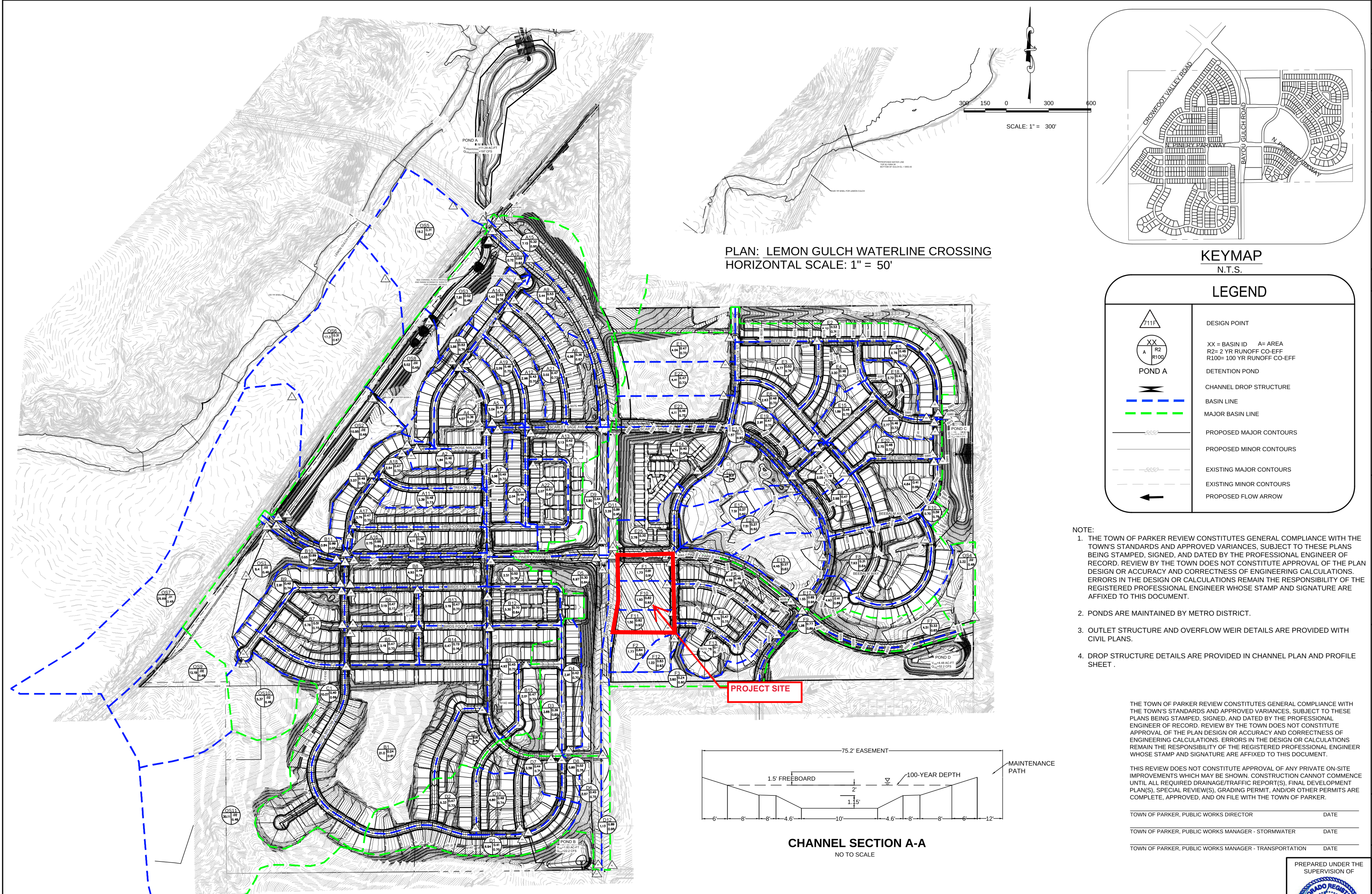

**PLAN: LEMON GULCH WATERLINE CROSSING**  
 HORIZONTAL SCALE: 1" = 50'

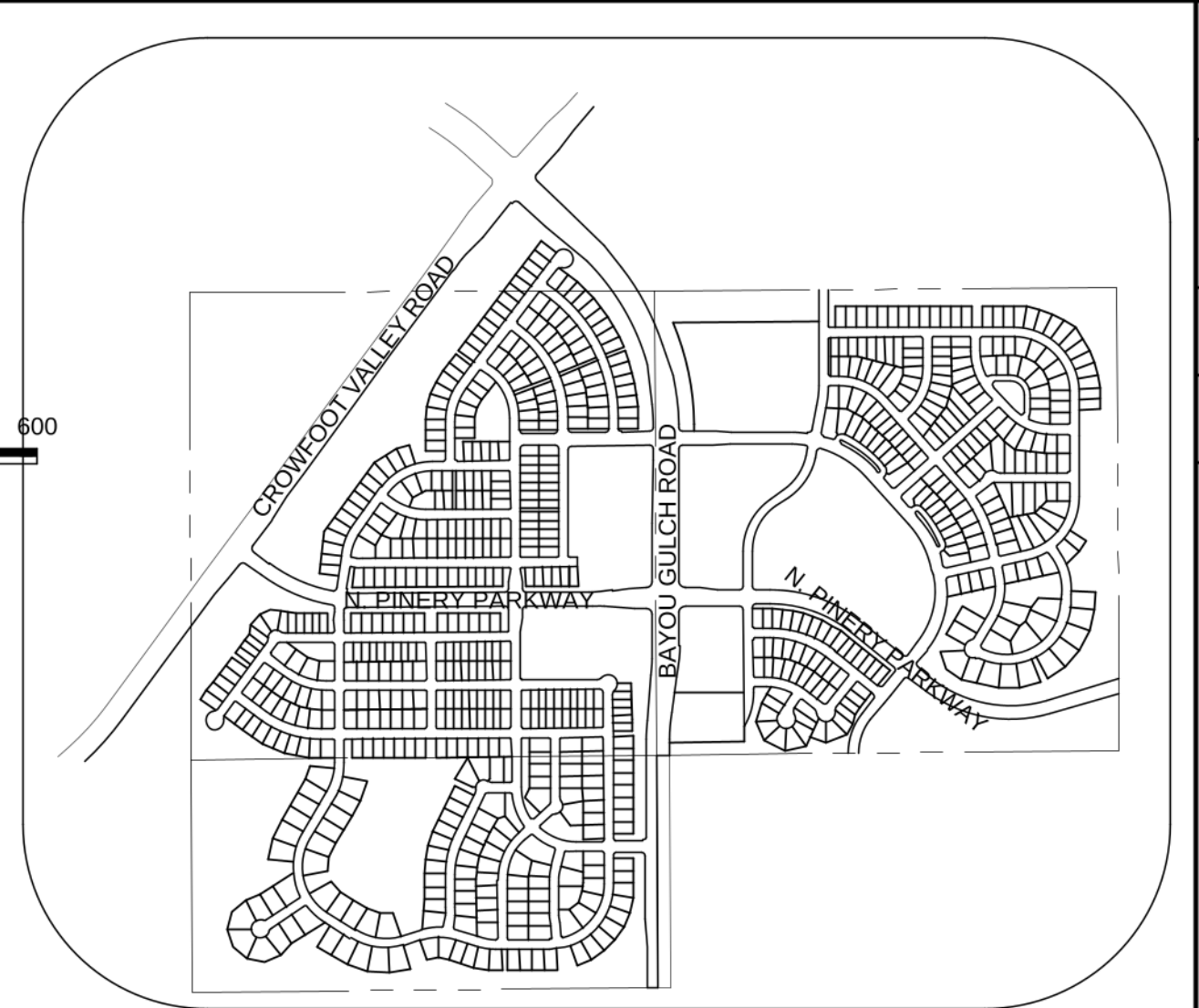

**KEYMAP**  
 N.T.S.

**LEGEND**

|  |  |
|--|--|
|  | DESIGN POINT   |
|  | XX = BASIN ID    A= AREA<br>R2= 2 YR RUNOFF CO-EFF<br>R100= 100 YR RUNOFF CO-EFF |
|  | DETENTION POND   |
|  | CHANNEL DROP STRUCTURE   |
|  | BASIN LINE   |
|  | MAJOR BASIN LINE   |
|  | PROPOSED MAJOR CONTOURS  |
|  | PROPOSED MINOR CONTOURS  |
|  | EXISTING MAJOR CONTOURS  |
|  | EXISTING MINOR CONTOURS  |
|  | PROPOSED FLOW ARROW  |

- NOTE:
1. THE TOWN OF PARKER REVIEW CONSTITUTES GENERAL COMPLIANCE WITH THE TOWN'S STANDARDS AND APPROVED VARIANCES, SUBJECT TO THESE PLANS BEING STAMPED, SIGNED, AND DATED BY THE PROFESSIONAL ENGINEER OF RECORD. REVIEW BY THE TOWN DOES NOT CONSTITUTE APPROVAL OF THE PLAN DESIGN OR ACCURACY AND CORRECTNESS OF ENGINEERING CALCULATIONS. ERRORS IN THE DESIGN OR CALCULATIONS REMAIN THE RESPONSIBILITY OF THE REGISTERED PROFESSIONAL ENGINEER WHOSE STAMP AND SIGNATURE ARE AFFIXED TO THIS DOCUMENT.
  2. PONDS ARE MAINTAINED BY METRO DISTRICT.
  3. OUTLET STRUCTURE AND OVERFLOW WEIR DETAILS ARE PROVIDED WITH CIVIL PLANS.
  4. DROP STRUCTURE DETAILS ARE PROVIDED IN CHANNEL PLAN AND PROFILE SHEET.

THE TOWN OF PARKER REVIEW CONSTITUTES GENERAL COMPLIANCE WITH THE TOWN'S STANDARDS AND APPROVED VARIANCES, SUBJECT TO THESE PLANS BEING STAMPED, SIGNED, AND DATED BY THE PROFESSIONAL ENGINEER OF RECORD. REVIEW BY THE TOWN DOES NOT CONSTITUTE APPROVAL OF THE PLAN DESIGN OR ACCURACY AND CORRECTNESS OF ENGINEERING CALCULATIONS. ERRORS IN THE DESIGN OR CALCULATIONS REMAIN THE RESPONSIBILITY OF THE REGISTERED PROFESSIONAL ENGINEER WHOSE STAMP AND SIGNATURE ARE AFFIXED TO THIS DOCUMENT.

THIS REVIEW DOES NOT CONSTITUTE APPROVAL OF ANY PRIVATE ON-SITE IMPROVEMENTS WHICH MAY BE SHOWN. CONSTRUCTION CANNOT COMMENCE UNTIL ALL REQUIRED DRAINAGE/TRAFFIC REPORT(S), FINAL DEVELOPMENT PLAN(S), SPECIAL REVIEW(S), GRADING PERMIT, AND/OR OTHER PERMITS ARE COMPLETE, APPROVED, AND ON FILE WITH THE TOWN OF PARKER.

TOWN OF PARKER, PUBLIC WORKS DIRECTOR \_\_\_\_\_ DATE \_\_\_\_\_  
 TOWN OF PARKER, PUBLIC WORKS MANAGER - STORMWATER \_\_\_\_\_ DATE \_\_\_\_\_  
 TOWN OF PARKER, PUBLIC WORKS MANAGER - TRANSPORTATION \_\_\_\_\_ DATE \_\_\_\_\_

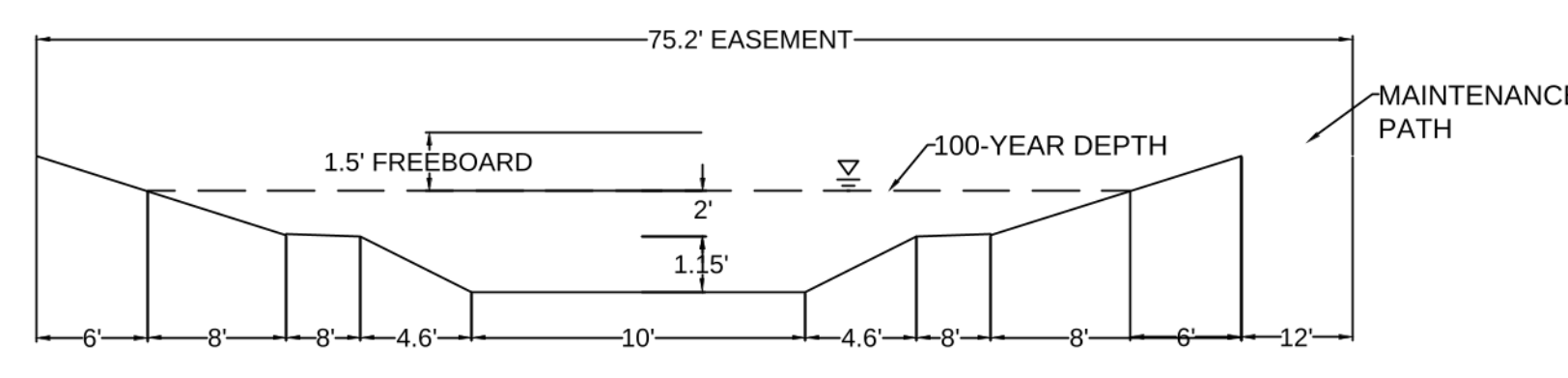

**CHANNEL SECTION A-A**  
 NO TO SCALE

**PLAN: OVERALL DRAINAGE MAP**  
 HORIZONTAL SCALE: 1" = 50'

**BENCHMARK**  
 THE DOUGLAS COUNTY CONTROL POINT KNOWN AS 1.060032, BEING A 3-1/4" ALUMINUM CAP, BEING LOCATED IN THE SOUTHWEST QUARTER OF SECTION 33, TOWNSHIP 6 SOUTH, RANGE 66 WEST OF THE SIXTH PRINCIPAL MERIDIAN, HAVING A PUBLISHED ELEVATION OF 1799.2870 METERS (5903.13 FEET) NAVD '88 DATUM.

**BASIS OF BEARINGS:**  
 THE EAST LINE OF THE NORTHEAST QUARTER OF SAID SECTION 9 BEING MONUMENTED AT THE NORTHEAST CORNER OF SAID SECTION 9 BY A 3-1/4" ALUMINUM CAP STAMPED LS 23053 AND AT THE EAST QUARTER CORNER OF SAID SECTION 9 BY A 2-1/2" ALUMINUM CAP STAMPED LS 6935 BEING CONSIDERED TO BEAR SOUTH 00°15'06" EAST, 2648.70 FEET.

**CALL 811**  
 TWO WORKING DAYS  
**BEFORE YOU DIG**  
 1-800-922-1987  
 UNCC  
 UTILITY NOTIFICATION  
 CENTER OF COLORADO

PREPARED UNDER THE SUPERVISION OF  
  
 MARK SCHEURER  
 COLORADO P.E. 48988

|  |               |                |                |   |          |   |            |
|--|---------------|----------------|----------------|---|----------|---|------------|
| SHEET NUMBER   | DRAWN BY: AYK | CHECKED BY: JJ | DATE: MAY 2017 | SCALE:  | AS SHOWN | FILE NO:  | 8130283701 |
|  |               |                |                | TOWN OF PARKER, PUBLIC WORKS DIRECTOR                                 | DATE     | TOWN OF PARKER, PUBLIC WORKS MANAGER - STORMWATER | DATE       |
|  |               |                |                | TOWN OF PARKER, PUBLIC WORKS MANAGER - TRANSPORTATION                 | DATE     |   |            |
|  |               |                |                | <br>MARK SCHEURER<br>COLORADO P.E. 48988                              |          |   |            |
| <b>TRAILS AT CROWFOOT</b><br><b>FINAL DRAINAGE MAP</b><br>OVERALL DRAINAGE MAP                           |               |                |                | <b>ESX MANAGEMENT</b><br>7353 South Alton Way<br>CENTENNIAL, CO 80112 |          |   |            |
| 10338 E. Dry Creek Rd.<br>Suite 240<br>Englewood, CO 80155<br>Tel: (720) 482-9526<br>Fax: (720) 482-9546 |               |                |                |   |          |   |            |
| No.  | Revisions     | Date           | Appr.          | Date  |          |   |            |

Note: 1) 0% slope indicates sump inlet. DIRECT FLOW BASIN ID AREA Imperviousness Q2 Q100 Street Type Slope

Note: 1) 0% slope indicates sump inlet. DIRECT FLOW BASIN ID AREA Imperviousness Q2 Q100 Street Type Slope

Note: 1) 0% slope indicates sump inlet. DIRECT FLOW BASIN ID AREA Imperviousness Q2 Q100 Street Type Slope

Note: 1) 0% slope indicates sump inlet. DIRECT FLOW BASIN ID AREA Imperviousness Q2 Q100 Street Type Slope

Note: 1) 0% slope indicates sump inlet. DIRECT FLOW BASIN ID AREA Imperviousness Q2 Q100 Street Type Slope

CUMULATIVE FLOW Design Point Q2 Q100 ID (CFS) (CFS)

CUMULATIVE FLOW Design Point Q2 Q100 ID (CFS) (CFS)

CUMULATIVE FLOW Design Point Q2 Q100 ID (CFS) (CFS)

CUMULATIVE FLOW Design Point Q2 Q100 ID (CFS) (CFS)

CUMULATIVE FLOW Design Point Q2 Q100 ID (CFS) (CFS)

CHANNEL DESIGN POINT SUMMARY Design Point Q5 Q100 ID (CFS) (CFS)

POND A Description Drainage Area (FT) 174.49 Percent Imperviousness (%) 37.55

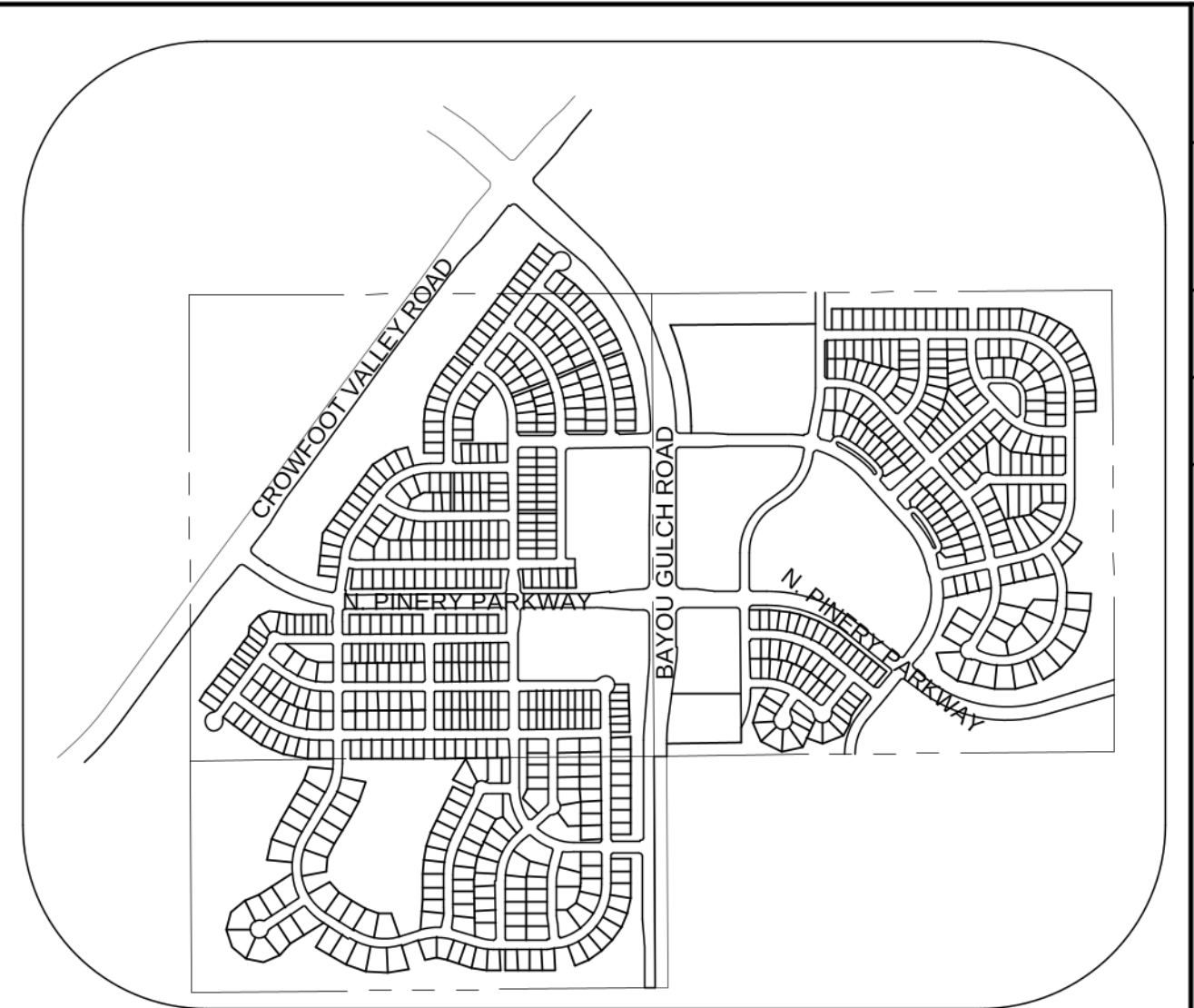

KEYMAP N.T.S.

- NOTE: 1. THE TOWN OF PARKER REVIEW CONSTITUTES GENERAL COMPLIANCE WITH THE TOWN'S STANDARDS AND APPROVED VARIANCES...

Table with columns: No., Revisions, Date, Appr., Date

CVL CONSULTANTS logo and address: 10338 E. Dry Creek Rd., Suite 240, Englewood, CO 80152

ESX MANAGEMENT logo and address: 7353 South Alton Way, CENTENNIAL, CO 80112

TRAILS AT CROWFOOT FINAL DRAINAGE MAP OVERALL DRAINAGE MAP - TABLES

SCALE: AS SHOWN FILE NO: 8130283701 DRAWN BY: AXK CHECKED BY: JU DATE: MAY 2017

CALL 811 TWO WORKING DAYS BEFORE YOU DIG UNCC 1-800-922-1987

DIRECT FLOW BASIN ID AREA Imperviousness Q2 Q100 Street Type Slope

BENCHMARK DOUGLAS COUNTY CONTROL POINT KNOWN AS 1.060032, BEING A 3-1/4" ALUMINUM CAP, BEING LOCATED IN THE SOUTHWEST QUARTER OF SECTION 33...

BASIS OF BEARINGS: THE EAST LINE OF THE NORTHEAST QUARTER OF SAID SECTION 9 BEING MONUMENTED AT THE NORTHEAST CORNER OF SAID SECTION 9...

PROFESSIONAL ENGINEER MARK SCHEURER COLORADO P.E. 48988

SHEET NUMBER 1B

**APPENDIX E**  
**Developed Drainage Map**

P:\KUM & GO\COLO. PARKER\_2299 - PINERY AND BAYOU GULCH\B CADD\DRAINAGE\1.1 - DEVELOPED DRAINAGE MAP.DWG

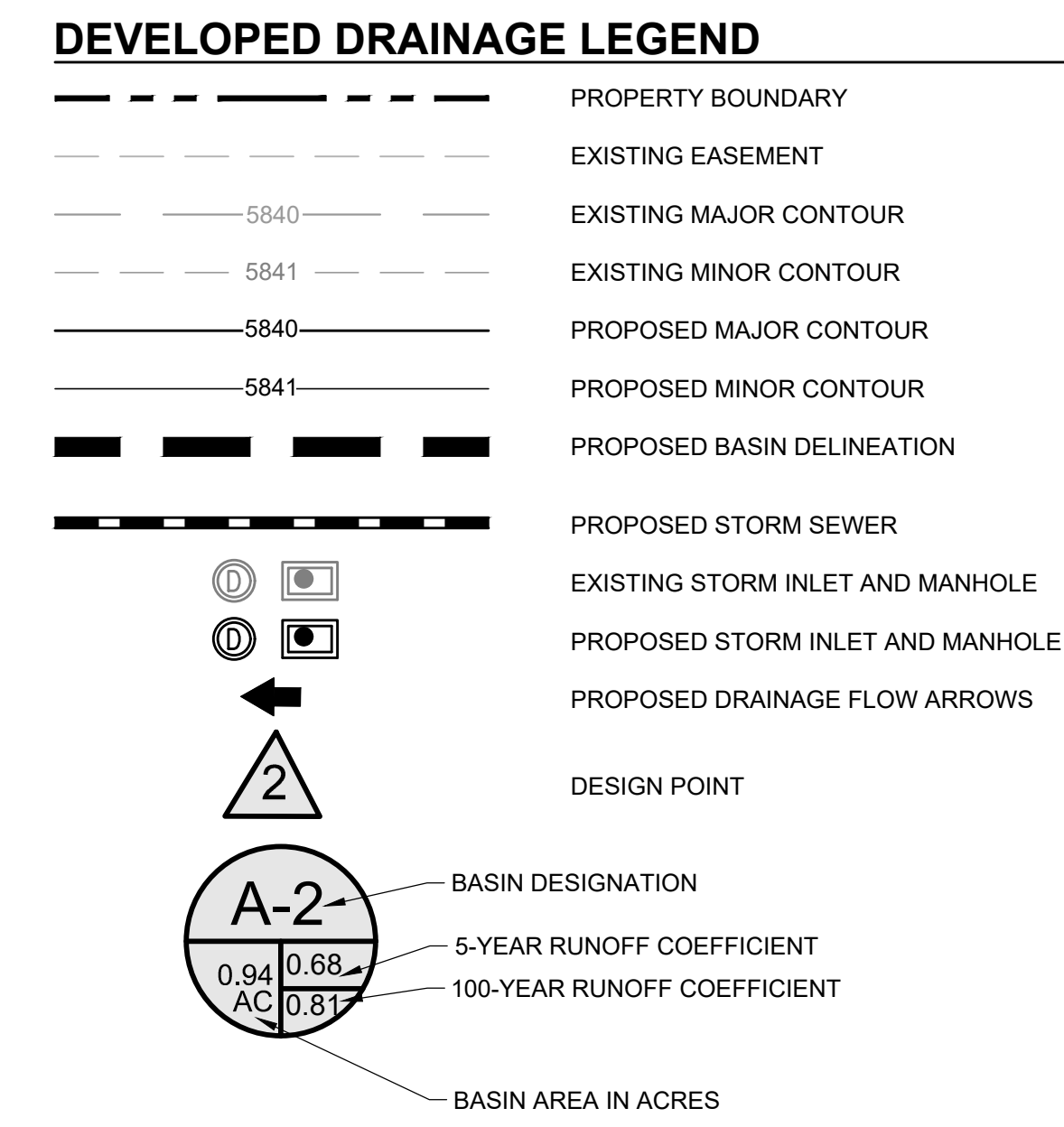
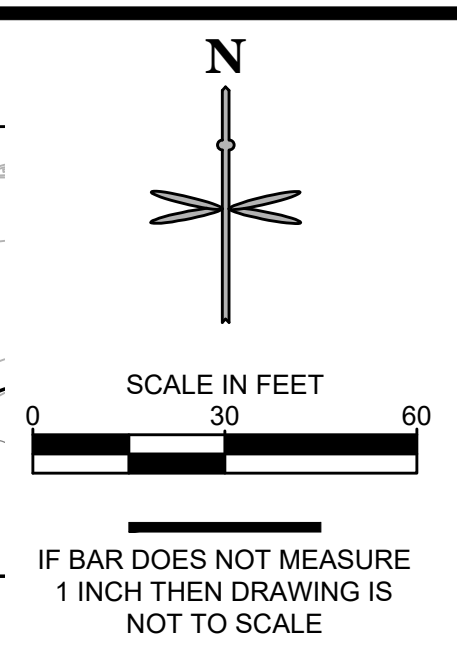
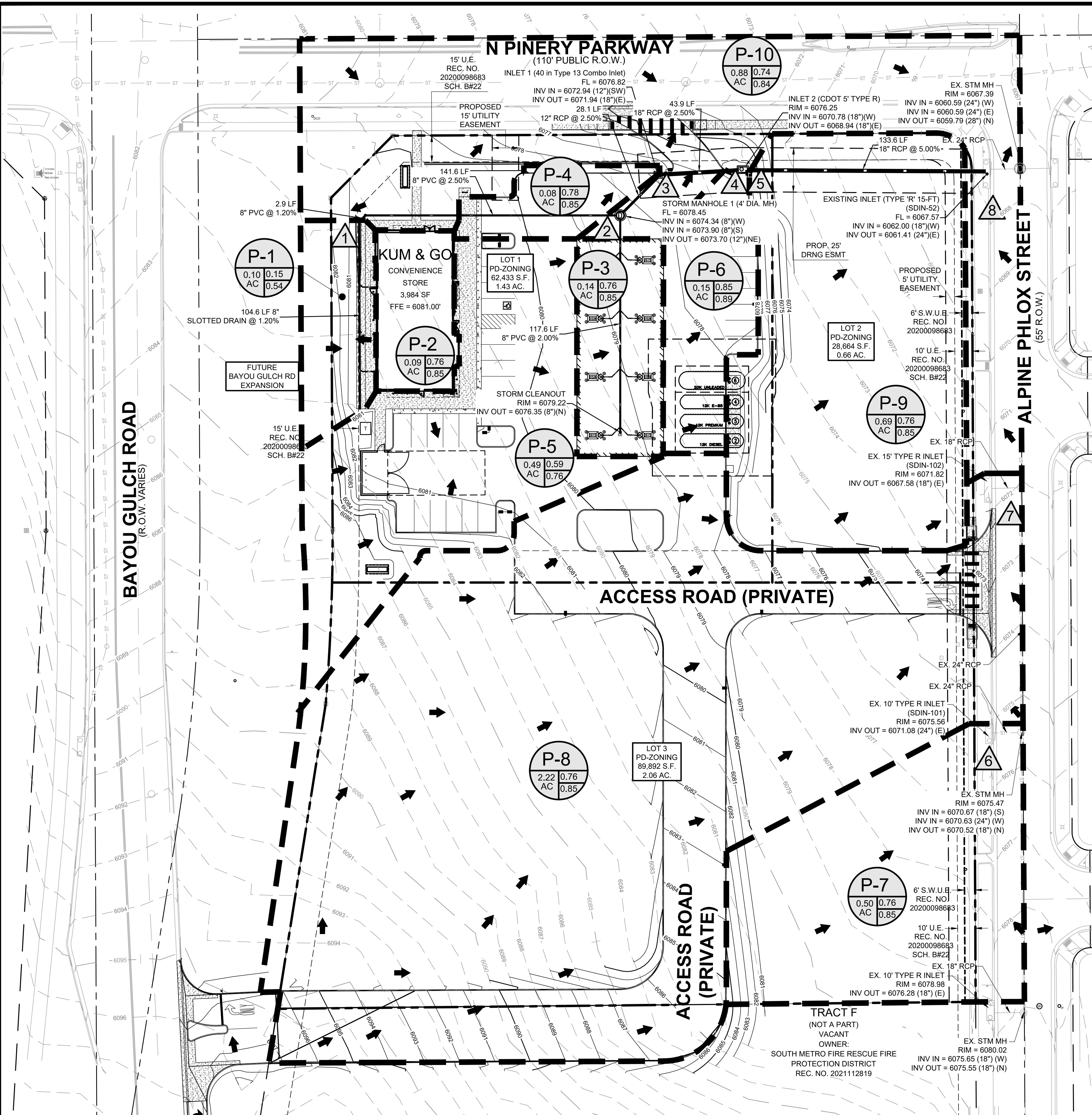

#### DEVELOPED RUNOFF SUMMARY TABLE

| DESIGN POINT | TRIBUTARY BASIN | TRIBUTARY AREA (AC) | COEFFICIENT |      | TOTAL RUNOFF |            |
|--------------|-----------------|---------------------|-------------|------|--------------|------------|
|              |                 |                     | C5          | C100 | Q5 (CFS)     | Q100 (CFS) |
| 1            | P-1             | 0.11                | 0.14        | 0.54 | 0.08         | 0.53       |
|              | P-2             | 0.09                | 0.76        | 0.85 | 0.34         | 0.70       |
| 2            | P-1 & P-2       | 0.21                |             |      | 0.41         | 1.23       |
|              | P-3             | 0.14                | 0.76        | 0.85 | 0.49         | 1.03       |
| 3            | DP1 & P-3       | 0.34                |             |      | 0.84         | 2.15       |
|              | P-4             | 0.08                | 0.78        | 0.85 | 0.28         | 0.57       |
| 4            | DP2 & P-4       | 0.42                |             |      | 1.09         | 2.68       |
|              | P-5             | 0.50                | 0.59        | 0.76 | 1.34         | 3.21       |
| 5            | P-6             | 0.15                | 0.85        | 0.89 | 0.60         | 1.18       |
|              | P-5 & P-6       | 0.65                |             |      | 1.92         | 4.35       |
| 6            | DP3 & DP4       | 1.07                |             |      | 2.91         | 6.94       |
|              | P-7             | 0.50                | 0.76        | 0.85 | 1.73         | 3.63       |
| 7            | P-8             | 2.21                | 0.76        | 0.85 | 7.51         | 15.72      |
|              | P-9             | 0.69                | 0.76        | 0.85 | 2.46         | 5.14       |
| 8            | P-10            | 0.88                | 0.61        | 0.77 | 2.41         | 5.68       |
|              | P-9 + P-10      | 1.57                |             |      | 4.74         | 10.54      |

**BENCHMARK:**  
ELEVATIONS ARE BASED UPON A POST-PROCESSED STATIC GNSS CONNECTION MADE TO DOUGLAS COUNTY GIS POINT 1.051038 BEING A FOUND 3.25" ALLOY CAP STAMPED "DOUGLAS COUNTY - 1.051038 - SECONDARY CONTROL MONUMENT" UTILIZING GEOID 18 TO MODEL THE ELLIPSOID SEPARATION AND HAVING A PUBLISHED ELEVATION OF 6053.87 FEET (NAVD 88). SITE BENCHMARK: FWS CONTROL POINT 501 BEING A SET NO. 5 REBAR WITH A 2" ALLOY CAP STAMPED "FWS CONTROL POINT" LOCATED APPROXIMATELY 144.5' SOUTH OF THE INTERSECTION OF THE CENTER LINES OF NORTH PINERY PARKWAY AND ALPINE PHLOX STREET AND 23' WEST OF THE CENTER-LINE OF ALPINE PHLOX STREET HAVING AN ESTABLISHED ELEVATION OF 6069.33' NAVD 88

**811** Know what's below. Call before you dig.  
CALL 811 SEVENTY-TWO HOURS PRIOR TO DIGGING, GRADING OR EXCAVATING FOR THE MARKING OF UNDERGROUND MEMBER UTILITIES.

**EES** ENGINEERING AND ENVIRONMENTAL SOLUTIONS, INC.  
3901 E. Florida Avenue, Suite 425  
Denver, CO 80210  
303-572-7997 www.ees.us.com

PRELIMINARY NOT FOR CONSTRUCTION

1459 Grand Ave  
Des Moines, IA 50309  
P: 888-458-6646

2293 - PARKER, COLORADO  
BAYOU GULCH RD AND PINERY PKWY  
DEVELOPED DRAINAGE MAP

KG PROJECT TEAM:  
RDM:  
SDM:  
CPM:

| REVISION DESCRIPTION | DATE |
|----------------------|------|
|                      |      |
|                      |      |
|                      |      |

DATE: 06-23-2023  
SHEET NUMBER: D1.0  
1 OF 1