

11/25/2024

Town of Parker
20120 E. Mainstreet
Parker, CO 80138

RE: Land of Sushi – Crown Point Filing #1, Lot 4E, Drainage Conformance Letter

To Whom It May Concern,

The purpose of this letter is to show that the proposed development of the Land of Sushi on Lot 4E of Crown Point Filing #1 conforms to the requirements of the “*Phase III Drainage Study for Boondocks Entertainment Facility*” prepared by MM&D Engineering dated December 21, 2014.

Based on the “*Phase III Drainage Study for Boondocks Entertainment Facility*” Lot 4E is fully or partially apart of the following drainage Basins: A11, A12, A13, A14, A15, A16 & B1 which contains 1.08 acres of Lot 4E. This area is the part of lot that will be developed with this project. Basin A, along with the other Basins comprising the Crown Point Filing #1 development, eventually drain to a 42” storm line that crosses 18800 Rd. per the Crown Point Filing 1 14th Amendment drainage report. All flows and water quality/detention have been accommodated with the design of Crown point Filing 1.

The proposed OS1 and OS2 Basin correlates to Basin B1 from the “*Phase III Drainage Study for Boondocks Entertainment Facility*”. These basins have a decrease in imperviousness (12.2% vs 29.7%) than the anticipated Basin B1 and which generate smaller flows, thus downstream infrastructure will experience no adverse impacts. All flows will continue to Cottonwood Dr and 18800DFR where it is captured by a 10’ Type R inlet at the intersection of Cottonwood Dr. and 18800 Rd.

Basin OS3 will be conveyed to Cottonwood Drive where it will combine with OS2 and travel west along Cottonwood Drive where it is captured by the same 10’ Type R inlet described above. Total flow from Basin B1 Check (Exhibit provided) = 2.0 CFS compared to the proposed combined flow of OS1, OS2, and OS3 = 1.4 CFS. Thus, the inlet downstream has capacity for these offsite flows in the proposed condition.

The assumed flows from the developed lot for a 5-year and 100-year storm are 2.9 cfs and 7.1 cfs respectively.

The calculations for post-development Basin A (Lot 4E) for both the 5-year and 100-year storm are attached as part of Appendix A at the end of this letter. *Phase III Drainage Study for Boondocks Entertainment Facility* drainage map and calculation for Basin A are included in Appendix D. Inlet capacities are included in Appendix B.

The Land of Sushi site was broken into six on-site sub-basins as follows and as shown on the Drainage Map included in Appendix C:

- Basin A1 (0.15 ac, 90% impervious) – Building roof area collected by roof drain system and connected to proposed storm line
- Basin A2 (0.40 ac, 87.9% impervious) – Contains eastern portion of the site which includes drive aisle and parking. Flows are captured by proposed Combo Type 13 inlet.
- Basin A3 (0.24 ac, 90% impervious) – Contains drive aisle, parking, and sidewalk south of the proposed building. Flows are captured by proposed Type 13 inlet.

The hydraulic grade lines were modeled in the 5-year and 100-year event based on the downstream assumptions. It was determined that the 100-year event HGL for the Storm Line A is unable to be a



minimum of 1 foot below finished grade. The HGL is below grade in this event. A variance is being requested, as the downstream constraints of the existing HGL at storm manhole S-4 is unable to be changed.

VARIANCES

The following variance is being requested from the SDECM:

Section 6.3.3.4 Hydraulic Design

In the major storm event, the hydraulic grade must be located 12-inches below finished grade as a maximum condition.

Based on existing hydraulics, the HGL at the existing storm manhole S-4 is approximately at elevation 5798.90. Therefore, as additional flow enters this system the HGL rises and is unable to provide the 1 foot minimum below finished grade. The HGL does remain below finished grade in the major storm event.

The actual design for Lot 4E is 1.08 acres which slightly differs from the Phase III Drainage Study as the proposed site is more refined. The approximate site imperviousness of 68% is less than the anticipated 70.6% imperviousness from the Phase III Drainage Study. Therefore, the Land of Sushi project follows the Final Drainage Report and there should be no adverse effects on the downstream system.

Sincerely,
GALLOWAY

Matthew Pepin
Civil Project Engineer



11/25/2024

Appendices:

Appendix A – Hydrologic & Hydraulic Computations

Appendix B – Inlet Calcs

Appendix C – Drainage Map

Appendix D – Excerpts from “*Phase III Drainage Study for Boondocks Entertainment Facility*”

Appendix A: Hydrologic & Hydraulic Computations

BASIN SUMMARY TABLE					
Tributary Sub-basin	Area (acres)	C ₅	C ₁₀₀	Q ₅ (cfs)	Q ₁₀₀ (cfs)
A1	0.15	0.77	0.85	0.6	1.1
A2	0.40	0.75	0.84	1.3	2.8
A3	0.24	0.77	0.85	0.8	1.8
OS1	0.06	0.41	0.67	0.1	0.4
OS2	0.20	0.05	0.49	0.0	0.9
OS3	0.03	0.05	0.49	0.0	0.1
Total On-Site	0.79	1.39	0.72	2.2	5.8
Total Site	1.08	0.64	0.82	2.9	7.1

COMPOSITE % IMPERVIOUS CALCULATIONS

Subdivision: Land of Sushi
 Location: CO, Parker

Project Name: Land of Sushi
 Project No.: LOS01
 Calculated By: MJP
 Checked By: SMB
 Date: 1/13/22

Basin ID	Total Area (ac)	Sidewalks and Drives			Lawns			Roofs			Basins Total Weighted % Imp.
		% Imp.	Area (ac)	Weighted % Imp.	% Imp.	Area (ac)	Weighted % Imp.	% Imp.	Area (ac)	Weighted % Imp.	
A1	0.15	90	0.00	0.0	2	0.00	0.0	90	0.15	90.00	90.0
A2	0.40	90	0.39	87.8	2	0.01	0.1	90	0.00	0.00	87.9
A3	0.24	90	0.24	90.0	2	0.00	0.0	90	0.00	0.00	90.0
OS1	0.06	90	0.03	45.0	2	0.03	1.0	90	0.00	0.00	46.0
OS2	0.20	90	0.00	0.0	2	0.20	2.0	90	0.00	0.00	2.0
OS3	0.03	90	0.00	0.0	2	0.03	2.0	90	0.00	0.00	2.0
OS1 + OS2	0.26	90	0.03	10.4	2	0.23	1.8	90	0.00	0.00	12.2
Total	1.08	90	0.66	55.0	2	0.27	0.5	90	0.15	12.50	68.0

STANDARD FORM SF-2
TIME OF CONCENTRATION

Subdivision: Land of Sushi
Location: CO, Parker

Project Name: Land of Sushi
Project No.: LOS01
Calculated By: MJP
Checked By: SMB
Date: 1/13/22

SUB-BASIN						INITIAL/OVERLAND			TRAVEL TIME					T _c CHECK			FINAL
DATA						(T _i)			(T _i)					(URBANIZED BASINS)			
BASIN ID	D.A. (AC)	Hydrologic Soils Group	Impervious (%)	C ₁₀₀	C ₅	L (FT)	S (%)	T _i (MIN)	L (FT)	S (%)	C _v	VEL. (FPS)	T _t (MIN)	COMP. T _c (MIN)	TOTAL LENGTH (FT)	Urbanized T _c (MIN)	T _c (MIN)
A1	0.15	C	90.0	0.85	0.77	30	2.0	2.6	0	0.8	20.0	1.7	0.0	2.6	30.0	10.2	5.0
A2	0.40	C	87.9	0.84	0.75	120	2.0	5.6	50	0.8	20.0	1.8	0.5	6.0	170.0	10.9	6.0
A3	0.24	C	90.0	0.85	0.77	50	1.2	4.0	60	0.8	20.0	1.8	0.6	4.6	110.0	10.6	5.0
OS1	0.06	C	46.0	0.67	0.41	30	6.0	3.8	45	2.0	20.0	2.8	0.3	4.1	75.0	10.4	5.0
OS2	0.20	C	2.0	0.49	0.05	40	20.0	4.5	0	1.0	20.0	2.0	0.0	4.5	40.0	10.2	5.0
OS3	0.03	C	2.0	0.49	0.05	10	25.0	2.1	0	1.0	20.0	2.0	0.0	2.1	10.0	10.1	5.0
B1-Check*	0.38	C	29.7	0.61	0.28	50	25.0	3.6	150	1.0	20.0	2.0	1.3	4.9	200.0	11.1	5.0

NOTES:

$T_i = (0.395 * (1.1 - C_s) * (L)^{0.5}) / ((S)^{0.33})$, S in ft/ft

$T_t = L / 60V$ (Velocity From Fig. 501)

Velocity $V = C_v * S^{0.5}$, S in ft/ft

$T_c \text{ Check} = 10 + L / 180$

For Urbanized basins a minimum T_c of 5.0 minutes is required.

For non-urbanized basins a minimum T_c of 10.0 minutes is required

STANDARD FORM SF-3
STORM DRAINAGE SYSTEM DESIGN
 (RATIONAL METHOD PROCEDURE)

Subdivision: Land of Sushi
 Location: CO Parker
 Design Storm: 5-Year

Project Name: Land of Sushi
 Project No.: LOS01
 Calculated By: MJP
 Checked By: SMB
 Date: 1/13/22

STREET	Design Point	DIRECT RUNOFF							TOTAL RUNOFF				STREET		PIPE			TRAVEL TIME			REMARKS
		Basin ID	Area (Ac)	Runoff Coeff.	Tc (min)	C*A (Ac)	I (in/hr)	Q (cfs)	Tc (min)	C*A (Ac)	I (in/hr)	Q (cfs)	Slope (%)	Street Flow (cfs)	Design Flow (cfs)	Slope (%)	Pipe Size (inches)	Length (ft)	Velocity (fps)	Tt (min)	
	1	A1	0.15	0.77	5.0	0.12	4.71	0.6													Total Flow to Roof Leaders
	2	A2	0.40	0.75	6.0	0.30	4.47	1.3													Total flow captured by Proposed Type 13 Inlet
	3	A3	0.24	0.77	5.0	0.18	4.71	0.8													Total flow captured by Proposed Type 13 Inlet
	4	OS1	0.06	0.41	5.0	0.02	4.71	0.1													Sheet flow to existing access drive
	5	OS2	0.20	0.05	5.0	0.01	4.71	0.0													Sheet flow to Cottonwood Dr.
	6	OS3	0.03	0.05	5.0	0.00	4.71	0.0													Sheet flow to Cottonwood Dr.
		B1-Check*	0.38	0.28	5.0	0.11	4.71	0.5													Derived From Existing Boondocks Drainage Report

STANDARD FORM SF-3
STORM DRAINAGE SYSTEM DESIGN
(RATIONAL METHOD PROCEDURE)

Subdivision: Land of Sushi
Location: CO, Parker
Design Storm: 100-Year

Project Name: Land of Sushi
Project No.: LOS01
Calculated By: MJP
Checked By: SMB
Date: 1/13/22

STREET	Design Point	DIRECT RUNOFF							TOTAL RUNOFF				STREET		PIPE			TRAVEL TIME			REMARKS
		Basin ID	Area (Ac)	Runoff Coeff.	Tc (min)	C*A (Ac)	I (in/hr)	Q (cfs)	Tc (min)	C*A (Ac)	I (in/hr)	Q (cfs)	Slope (%)	Street Flow (cfs)	Design Flow (cfs)	Slope (%)	Pipe Size (inches)	Length (ft)	Velocity (fps)	Tt (min)	
	1	A1	0.15	0.85	5.0	0.13	8.82	1.1													Total Flow to Roof Leaders
	2	A2	0.40	0.84	6.0	0.34	8.37	2.8													Total flow captured by Proposed Type 13 Inlet
	3	A3	0.24	0.85	5.0	0.20	8.82	1.8													Total flow captured by Proposed Type 13 Inlet
	4	OS1	0.06	0.67	5.0	0.04	8.82	0.4													Sheet flow to existing access drive
	5	OS2	0.20	0.49	5.0	0.10	8.82	0.9													Sheet flow to Cottonwood Dr.
	6	OS3	0.03	0.49	5.0	0.01	8.82	0.1													Sheet flow to Cottonwood Dr.
		B1-Check*	0.38	0.61	5.0	0.23	8.82	2.0													Derived From Existing Boondocks Drainage Report

STORMCAD SCHEMATIC

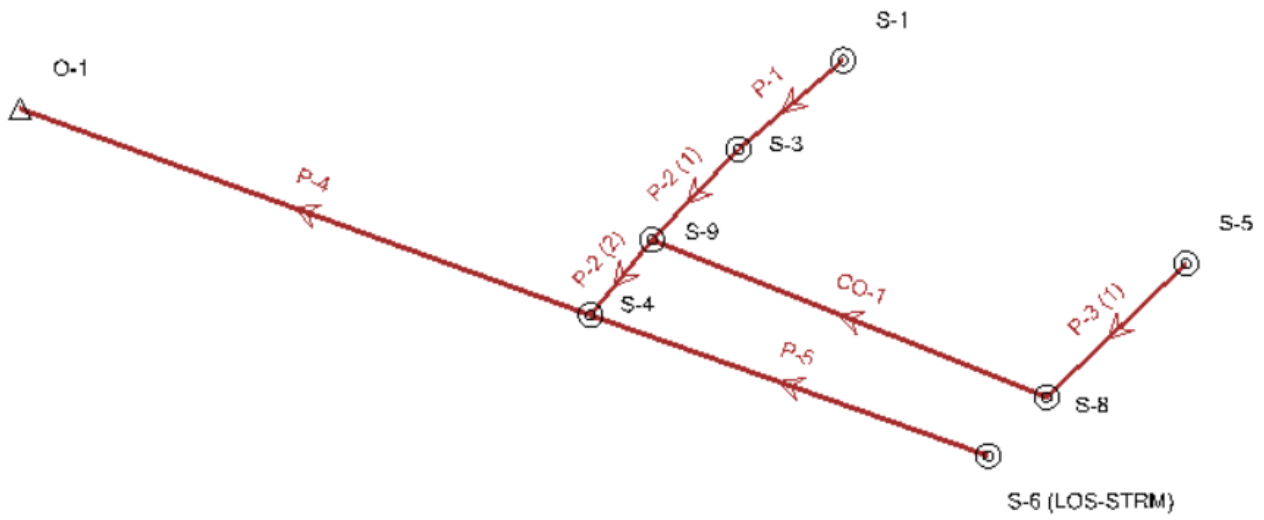

Scenario: 5-YR
Current Time Step: 0.000 h
FlexTable: GAL_Conduit

Label	Start Node	Stop Node	Invert (Start) (ft)	Invert (Stop) (ft)	Length (User Defined) (ft)	Slope (Calculated) (ft/ft)	Diameter (in)	Manning's n	Flow (cfs)	Velocity (ft/s)	Capacity (Full Flow) (cfs)	Hydraulic Grade Line (In) (ft)	Hydraulic Grade Line (Out) (ft)	Energy Grade Line (In) (ft)	Energy Grade Line (Out) (ft)	Headloss (ft)
P-4	S-4	O-1	5,797.26	5,790.37	148.2	0.046	18.0	0.013	7.80	11.63	22.64	5,798.34	5,790.98	5,798.85	5,793.08	7.36
P-5	S-6 (LOS-STRM)	S-4	5,798.49	5,797.26	103.0	0.012	18.0	0.013	5.40	6.40	11.48	5,799.39	5,798.90	5,799.76	5,799.05	0.49
P-1	S-1	S-3	5,798.88	5,798.71	33.5	0.005	6.0	0.013	0.50	2.55	0.40	5,799.39	5,799.07	5,799.49	5,799.24	0.32
P-2 (1)	S-3	S-9	5,797.72	5,797.56	29.6	0.005	18.0	0.013	1.10	3.10	7.73	5,798.95	5,798.94	5,798.95	5,798.95	0.00
P-2 (2)	S-9	S-4	5,797.56	5,797.46	22.2	0.004	18.0	0.013	2.40	3.59	7.00	5,798.91	5,798.90	5,798.94	5,798.93	0.01
P-3 (1)	S-5	S-8	5,798.33	5,798.07	53.0	0.005	18.0	0.013	1.30	3.14	7.36	5,798.96	5,798.95	5,799.01	5,798.98	0.00
CO-1	S-8	S-9	5,798.07	5,797.56	102.7	0.005	18.0	0.013	1.30	3.15	7.40	5,798.95	5,798.94	5,798.98	5,798.95	0.01

H:\LLand of Sush\Parker, CO_LOS000001_Cottonwood Drive\0CIV\Drain Reports\Prop\LOS01_StormCAD.stsw

Scenario: 5-YR
Current Time Step: 0.000 h
FlexTable: GAL_Manhole

Label	Elevation (Rim) (ft)	Elevation (Invert) (ft)	Hydraulic Grade Line (In) (ft)	Hydraulic Grade Line (Out) (ft)	Energy Grade Line (In) (ft)	Energy Grade Line (Out) (ft)	Headloss (ft)
S-1	5,803.51	5,798.88	5,799.39	5,799.39	5,799.49	5,799.49	0.00
S-3	5,800.18	5,797.36	5,798.95	5,798.95	5,799.12	5,798.95	0.00
S-4	5,802.39	5,797.26	5,798.90	5,798.34	5,799.05	5,798.85	0.56
S-5	5,803.32	5,798.33	5,798.96	5,798.96	5,799.01	5,799.01	0.00
S-6 (LOS-STRM)	5,803.48	5,798.49	5,799.80	5,799.39	5,800.17	5,799.76	0.41
S-8	5,803.44	5,798.07	5,798.95	5,798.95	5,798.98	5,798.98	0.00
S-9	5,801.80	5,797.56	5,798.94	5,798.91	5,798.95	5,798.94	0.04

H:\L\Land of Sushi\Parker, CO_LOS000001_Cottonwood Drive\0CIV\Drain Reports\Prop\LOS01_StormCAD.stsw

Scenario: 5-YR
Current Time Step: 0.000 h
FlexTable: GAL_Outfall

Label	Elevation (Invert) (ft)	Elevation (Rim) (ft)	Flow (Total Out) (cfs)	Boundary Condition Type	Elevation (User Defined Tailwater) (ft)
O-1	5,790.37	5,795.37	7.80	Free Outfall	-

H:\L\Land of Sushi\Parker, CO_LOS000001_Cottonwood Drive\0CIV\Drain Reports\Prop\LOS01_StormCAD.stsw

Profile Report
 Engineering Profile - STM-A (LOS01_StormCAD.stsw)
 Active Scenario: 5-YR

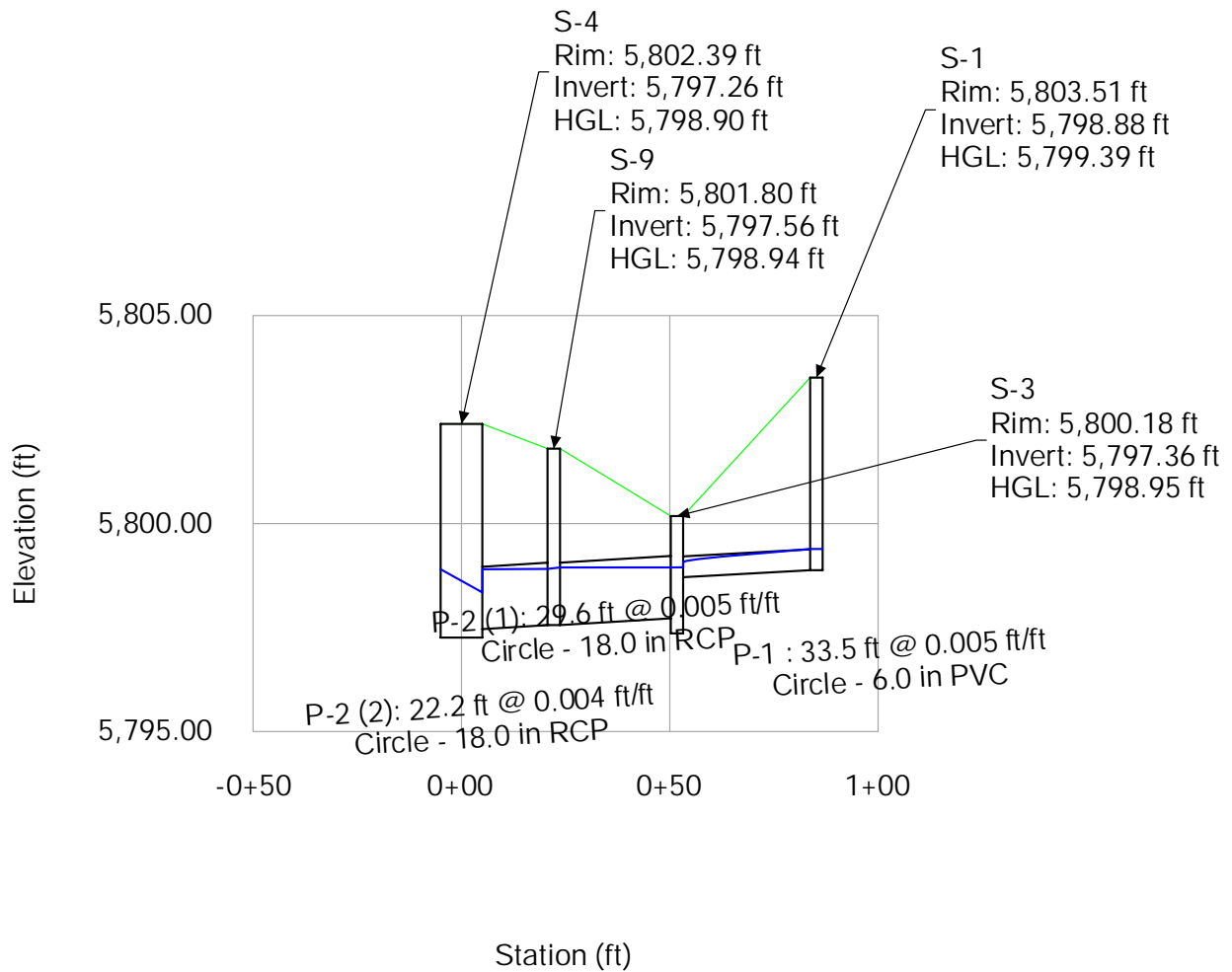

Profile Report
 Engineering Profile - STM-B (LOS01_StormCAD.stsw)
 Active Scenario: 5-YR

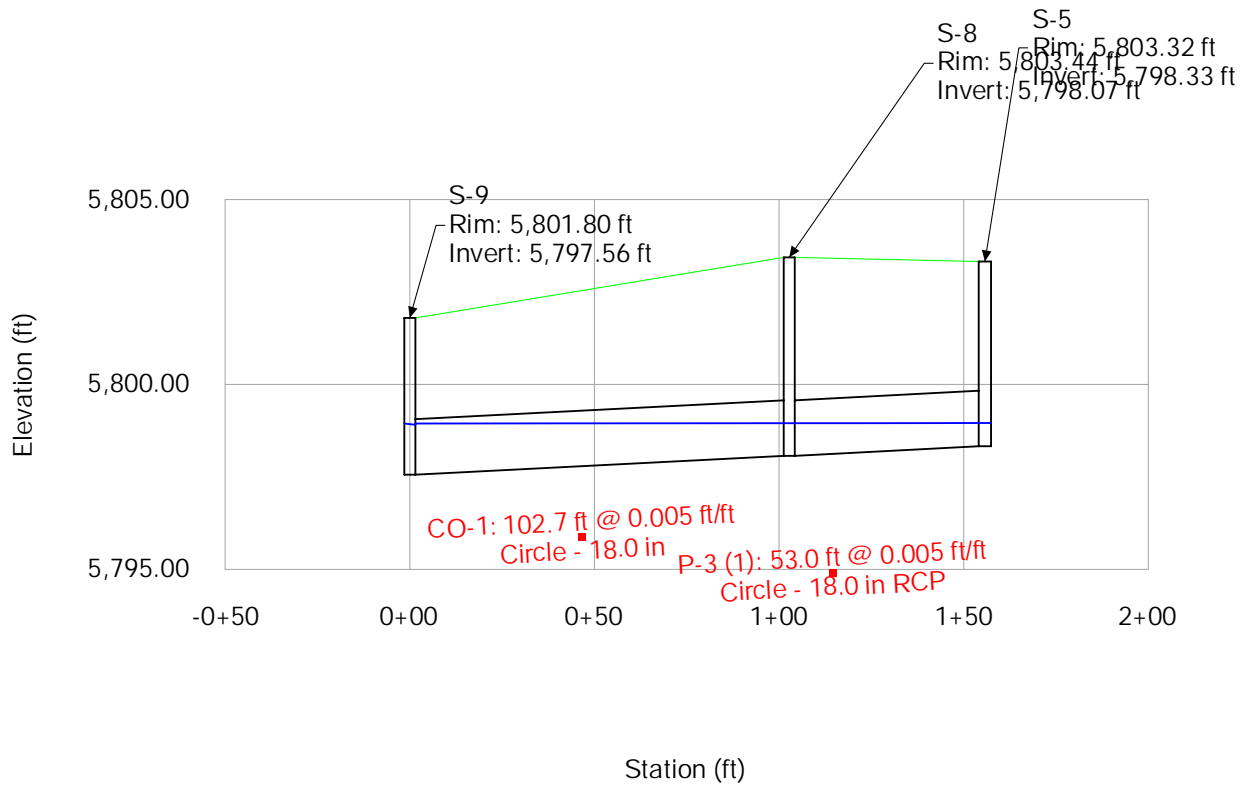

Profile Report
Engineering Profile - Profile - 3 (LOS01_StormCAD.stsw)
Active Scenario: 5-YR

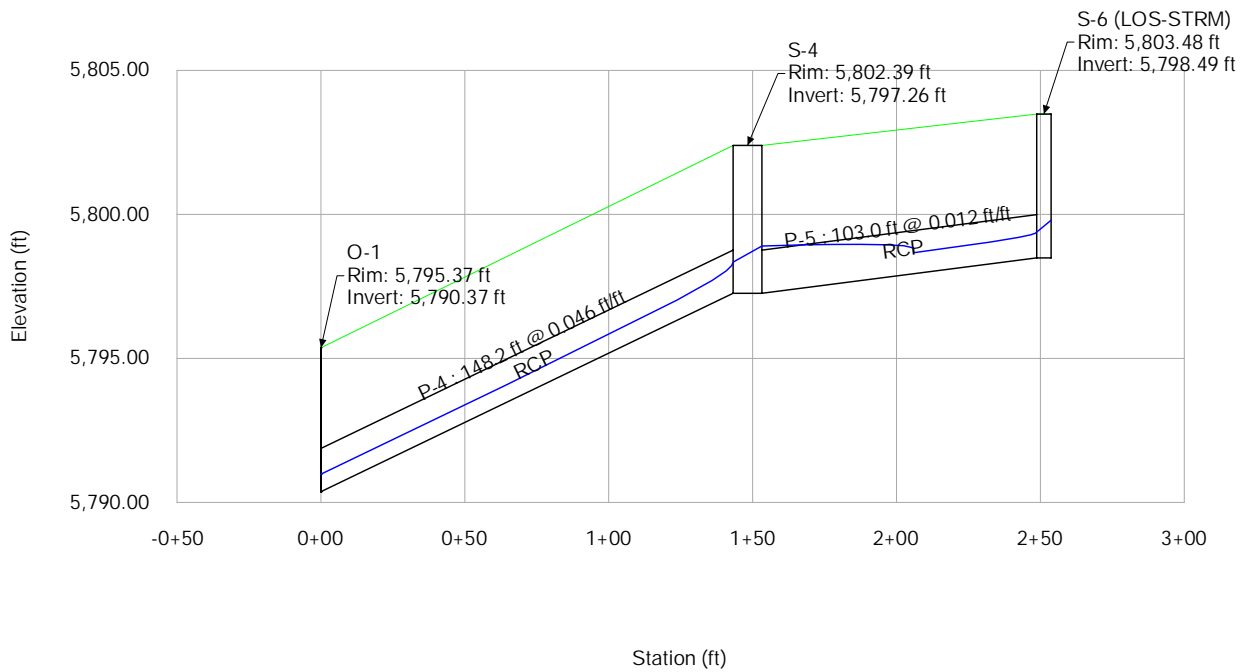

Scenario: 100-YR
 Current Time Step: 0.000 h
 FlexTable: GAL_Conduit

Label	Start Node	Stop Node	Invert (Start) (ft)	Invert (Stop) (ft)	Length (User Defined) (ft)	Slope (Calculated) (ft/ft)	Diameter (in)	Manning's n	Flow (cfs)	Velocity (ft/s)	Capacity (Full Flow) (cfs)	Hydraulic Grade Line (In) (ft)	Hydraulic Grade Line (Out) (ft)	Energy Grade Line (In) (ft)	Energy Grade Line (Out) (ft)	Headloss (ft)
P-4	S-4	O-1	5,797.26	5,790.37	148.2	0.046	18.0	0.013	14.30	13.55	22.64	5,798.65	5,791.24	5,799.74	5,794.09	7.41
P-5	S-6 (LOS-STRM)	S-4	5,798.49	5,797.26	103.0	0.012	18.0	0.013	8.60	4.87	11.48	5,800.54	5,799.85	5,800.91	5,800.22	0.69
P-1	S-1	S-3	5,798.88	5,798.71	33.5	0.005	6.0	0.013	1.10	5.60	0.40	5,801.40	5,800.12	5,801.89	5,800.60	1.29
P-2 (1)	S-3	S-9	5,797.72	5,797.56	29.6	0.005	18.0	0.013	2.90	1.64	7.73	5,800.11	5,800.09	5,800.16	5,800.13	0.02
P-2 (2)	S-9	S-4	5,797.56	5,797.46	22.2	0.004	18.0	0.013	5.70	3.23	7.00	5,799.91	5,799.85	5,800.08	5,800.01	0.07
P-3 (1)	S-5	S-8	5,798.33	5,798.07	53.0	0.005	18.0	0.013	2.80	1.58	7.36	5,800.20	5,800.16	5,800.24	5,800.20	0.04
CO-1	S-8	S-9	5,798.07	5,797.56	102.7	0.005	18.0	0.013	2.80	1.58	7.40	5,800.16	5,800.09	5,800.20	5,800.13	0.07

H:\LLand of Sush\Parker, CO_LOS000001_Cottonwood Drive\0CIV\Drain Reports\Prop\LOS01_StormCAD.stsw

Scenario: 100-YR
Current Time Step: 0.000 h
FlexTable: GAL_Manhole

Label	Elevation (Rim) (ft)	Elevation (Invert) (ft)	Hydraulic Grade Line (In) (ft)	Hydraulic Grade Line (Out) (ft)	Energy Grade Line (In) (ft)	Energy Grade Line (Out) (ft)	Headloss (ft)
S-1	5,803.51	5,798.88	5,801.40	5,801.40	5,801.89	5,801.89	0.00
S-3	5,800.18	5,797.36	5,800.12	5,800.11	5,800.60	5,800.16	0.00
S-4	5,802.39	5,797.26	5,799.85	5,798.65	5,800.22	5,799.74	1.20
S-5	5,803.32	5,798.33	5,800.20	5,800.20	5,800.24	5,800.24	0.00
S-6 (LOS-STRM)	5,803.48	5,798.49	5,800.94	5,800.54	5,801.31	5,800.91	0.40
S-8	5,803.44	5,798.07	5,800.16	5,800.16	5,800.20	5,800.20	0.00
S-9	5,801.80	5,797.56	5,800.09	5,799.91	5,800.13	5,800.08	0.18

H:\L\Land of Sushi\Parker, CO_LOS000001_Cottonwood Drive\0CIV\Drain Reports\Prop\LOS01_StormCAD.stsw

Scenario: 100-YR
Current Time Step: 0.000 h
FlexTable: GAL_Outfall

Label	Elevation (Invert) (ft)	Elevation (Rim) (ft)	Flow (Total Out) (cfs)	Boundary Condition Type	Elevation (User Defined Tailwater) (ft)
O-1	5,790.37	5,795.37	14.30	User Defined Tailwater	5,791.75

H:\Land of Sushi\Parker, CO_LOS000001_Cottonwood Drive\0CIV\Drain Reports\Prop\LOS01_StormCAD.stsw

Profile Report
 Engineering Profile - STM-A (LOS01_StormCAD.stsw)
 Active Scenario: 100-YR

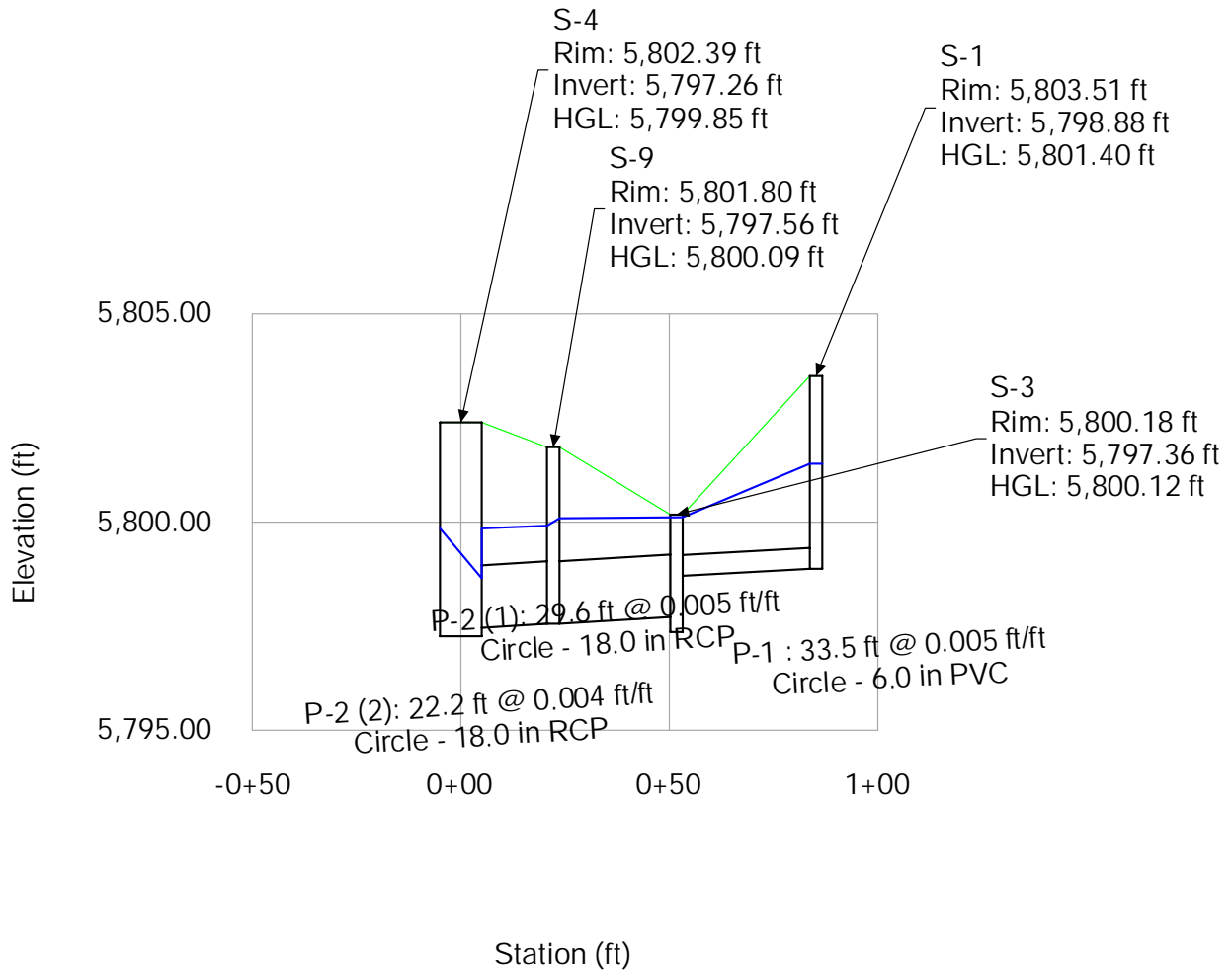

Profile Report
Engineering Profile - Profile - 3 (LOS01_StormCAD.stsw)
Active Scenario: 100-YR

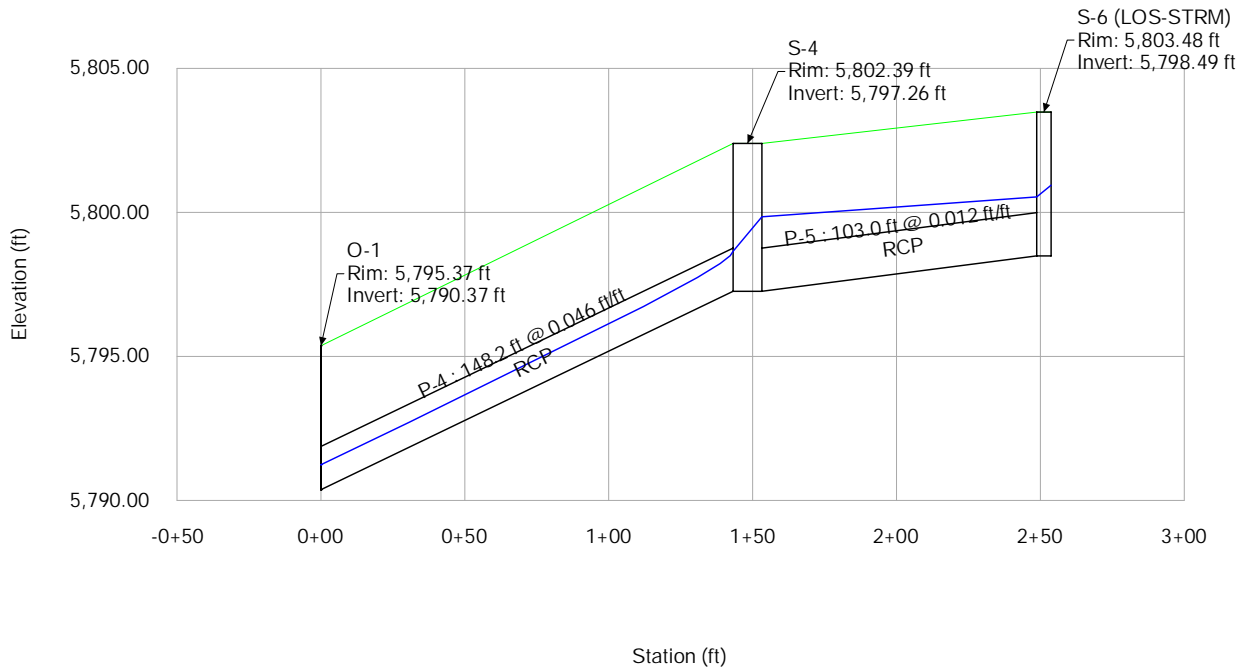

Profile Report
 Engineering Profile - STM-B (LOS01_StormCAD.stsw)
 Active Scenario: 100-YR

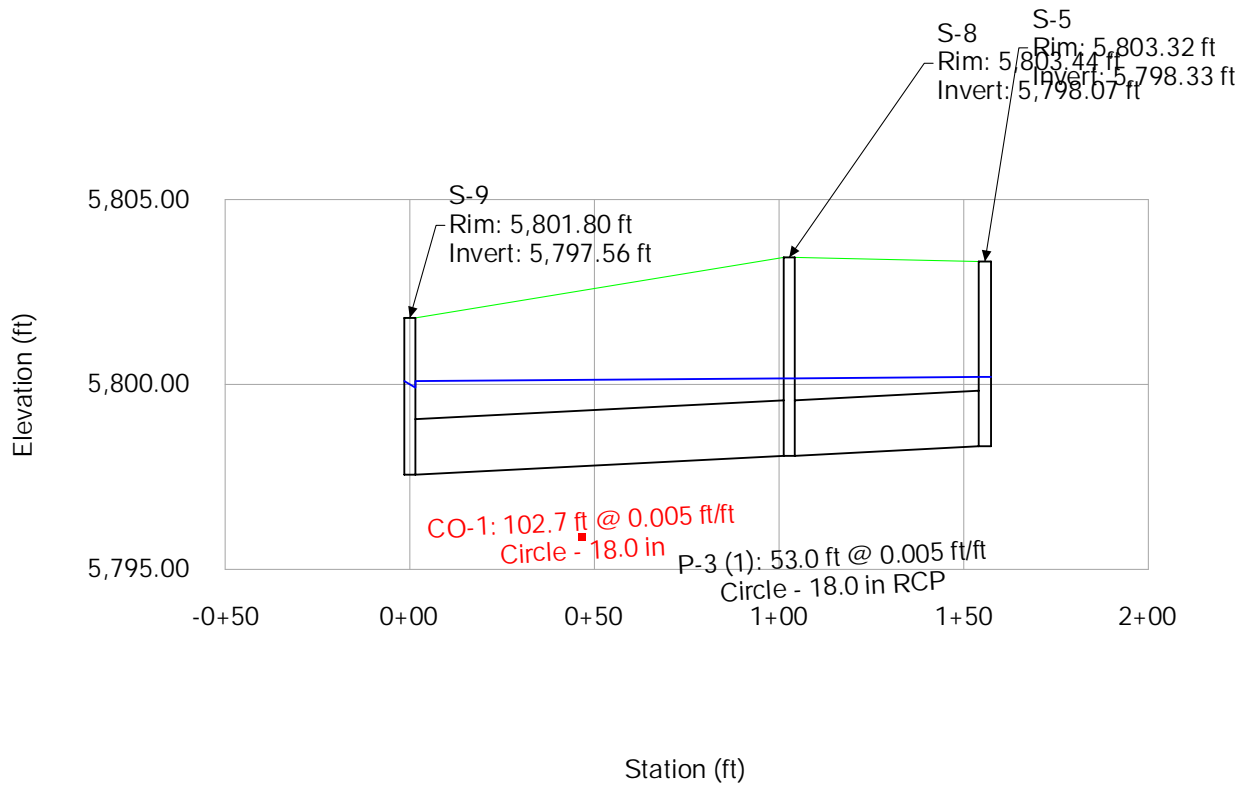

Appendix B: Inlet Calcs

INLET MANAGEMENT

Worksheet Protected

INLET NAME	Basin A2 DP2	Basin A3 DP 3
Site Type (Urban or Rural)	URBAN	URBAN
Inlet Application (Street or Area)	STREET	STREET
Hydraulic Condition	In Sump	In Sump
Inlet Type	CDOT/Denver 13 Combination	CDOT/Denver 13 Valley Gate

USER-DEFINED INPUT

User-Defined Design Flows		
Minor Q_{known} (cfs)	1.3	0.8
Major Q_{known} (cfs)	2.8	1.8
Bypass (Carry-Over) Flow from Upstream Inlets must be organized from upstream (left) to downstream (right) in order for bypa		
Receive Bypass Flow from:	No Bypass Flow Received	No Bypass Flow Received
Minor Bypass Flow Received, Q_b (cfs)		0.0
Major Bypass Flow Received, Q_b (cfs)		0.0
Watershed Characteristics		
Subcatchment Area (acres)		
Percent Impervious		
NRCS Soil Type		
Watershed Profile		
Overland Slope (ft/ft)		
Overland Length (ft)		
Channel Slope (ft/ft)		
Channel Length (ft)		
Minor Storm Rainfall Input		
Design Storm Return Period, T_r (years)		
One-Hour Precipitation, P_1 (inches)		
Major Storm Rainfall Input		
Design Storm Return Period, T_r (years)		
One-Hour Precipitation, P_1 (inches)		

CALCULATED OUTPUT

Minor Total Design Peak Flow, Q (cfs)	1.3	0.8
Major Total Design Peak Flow, Q (cfs)	2.8	1.8
Minor Flow Bypassed Downstream, Q_b (cfs)	N/A	N/A
Major Flow Bypassed Downstream, Q_b (cfs)	N/A	N/A

ALLOWABLE CAPACITY FOR ONE-HALF OF STREET (Minor & Major Storm)

(Based on Regulated Criteria for Maximum Allowable Flow Depth and Spread)

Project: LOS01_Land of Sushi

Inlet ID: Basin A2 | DP2

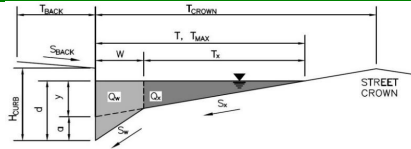

Gutter Geometry:

Maximum Allowable Width for Spread Behind Curb
 Side Slope Behind Curb (leave blank for no conveyance credit behind curb)
 Manning's Roughness Behind Curb (typically between 0.012 and 0.020)
 Height of Curb at Gutter Flow Line
 Distance from Curb Face to Street Crown
 Gutter Width
 Street Transverse Slope
 Gutter Cross Slope (typically 2 inches over 24 inches or 0.083 ft/ft)
 Street Longitudinal Slope - Enter 0 for sump condition
 Manning's Roughness for Street Section (typically between 0.012 and 0.020)

$T_{BACK} = 5.0$ ft
 $S_{BACK} = 0.020$ ft/ft
 $n_{BACK} = 0.035$

$H_{CURB} = 6.00$ inches
 $T_{CROWN} = 14.0$ ft
 $W = 2.00$ ft
 $S_X = 0.020$ ft/ft
 $S_W = 0.083$ ft/ft
 $S_0 = 0.000$ ft/ft
 $n_{STREET} = 0.016$

Max. Allowable Spread for Minor & Major Storm
 Max. Allowable Depth at Gutter Flowline for Minor & Major Storm
 Check boxes are not applicable in SUMP conditions

	Minor Storm	Major Storm	
$T_{MAX} =$	14.0	14.0	ft
$d_{MAX} =$	6.0	7.2	inches
	<input type="checkbox"/>	<input type="checkbox"/>	

MINOR STORM Allowable Capacity is not applicable to Sump Condition
 MAJOR STORM Allowable Capacity is not applicable to Sump Condition

$Q_{allow} =$

Minor Storm	Major Storm
SUMP	SUMP

 cfs

Warning 01

Warning 01: Manning's n-value does not meet the USDCM recommended design range.

INLET IN A SUMP OR SAG LOCATION

MHFD-Inlet, Version 5.02 (August 2022)

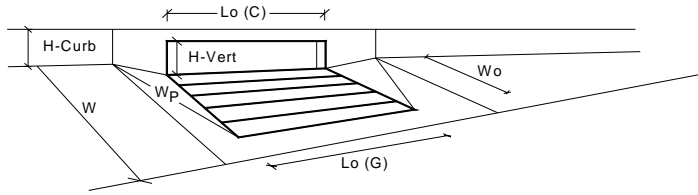

Design Information (Input)	MINOR	MAJOR	
Type of Inlet	CDOT/Denver 13 Combination		
Local Depression (additional to continuous gutter depression 'a' from above)	2.00	2.00	inches
Number of Unit Inlets (Grate or Curb Opening)	1	1	
Water Depth at Flowline (outside of local depression)	4.9	7.2	inches
Grate Information	MINOR	MAJOR	<input checked="" type="checkbox"/> Override
Length of a Unit Grate	3.00	3.00	feet
Width of a Unit Grate	1.73	1.73	feet
Open Area Ratio for a Grate (typical values 0.15-0.90)	0.43	0.43	
Clogging Factor for a Single Grate (typical value 0.50 - 0.70)	0.50	0.50	
Grate Weir Coefficient (typical value 2.15 - 3.60)	3.30	3.30	
Grate Orifice Coefficient (typical value 0.60 - 0.80)	0.60	0.60	
Curb Opening Information	MINOR	MAJOR	
Length of a Unit Curb Opening	3.00	3.00	feet
Height of Vertical Curb Opening in Inches	6.50	6.50	inches
Height of Curb Orifice Throat in Inches	5.25	5.25	inches
Angle of Throat (see USDCM Figure ST-5)	0.00	0.00	degrees
Side Width for Depression Pan (typically the gutter width of 2 feet)	2.00	2.00	feet
Clogging Factor for a Single Curb Opening (typical value 0.10)	0.10	0.10	
Curb Opening Weir Coefficient (typical value 2.3-3.7)	3.70	3.70	
Curb Opening Orifice Coefficient (typical value 0.60 - 0.70)	0.66	0.66	
Low Head Performance Reduction (Calculated)	MINOR	MAJOR	
Depth for Grate Midwidth	0.43	0.62	ft
Depth for Curb Opening Weir Equation	0.24	0.43	ft
Grated Inlet Performance Reduction Factor for Long Inlets	0.76	1.00	
Curb Opening Performance Reduction Factor for Long Inlets	N/A	N/A	
Combination Inlet Performance Reduction Factor for Long Inlets	0.76	1.00	
Total Inlet Interception Capacity (assumes clogged condition)	MINOR	MAJOR	
Inlet Capacity IS GOOD for Minor and Major Storms (>Q Peak)	2.8	6.8	cfs
Q _{PEAK REQUIRED}	1.3	2.8	cfs

ALLOWABLE CAPACITY FOR ONE-HALF OF STREET (Minor & Major Storm)

(Based on Regulated Criteria for Maximum Allowable Flow Depth and Spread)

Project: LOS01_Land of Sushi

Inlet ID: Basin A3 | DP 3

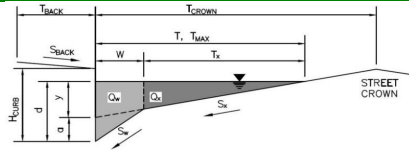

Gutter Geometry:

Maximum Allowable Width for Spread Behind Curb
 Side Slope Behind Curb (leave blank for no conveyance credit behind curb)
 Manning's Roughness Behind Curb (typically between 0.012 and 0.020)

$T_{BACK} = 5.0$ ft
 $S_{BACK} = 0.020$ ft/ft
 $n_{BACK} = 0.013$

Height of Curb at Gutter Flow Line
 Distance from Curb Face to Street Crown
 Gutter Width
 Street Transverse Slope
 Gutter Cross Slope (typically 2 inches over 24 inches or 0.083 ft/ft)
 Street Longitudinal Slope - Enter 0 for sump condition
 Manning's Roughness for Street Section (typically between 0.012 and 0.020)

$H_{CURB} = 4.00$ inches
 $T_{CROWN} = 32.0$ ft
 $W = 2.00$ ft
 $S_x = 0.020$ ft/ft
 $S_w = 0.083$ ft/ft
 $S_D = 0.000$ ft/ft
 $n_{STREET} = 0.016$

Max. Allowable Spread for Minor & Major Storm
 Max. Allowable Depth at Gutter Flowline for Minor & Major Storm
 Check boxes are not applicable in SUMP conditions

	Minor Storm	Major Storm	
$T_{MAX} =$	32.0	32.0	ft
$d_{MAX} =$	4.0	6.0	inches
	<input type="checkbox"/>	<input type="checkbox"/>	

MINOR STORM Allowable Capacity is not applicable to Sump Condition
 MAJOR STORM Allowable Capacity is not applicable to Sump Condition

$Q_{allow} =$

Minor Storm	Major Storm
SUMP	SUMP

 cfs

INLET IN A SUMP OR SAG LOCATION

MHFD-Inlet, Version 5.02 (August 2022)

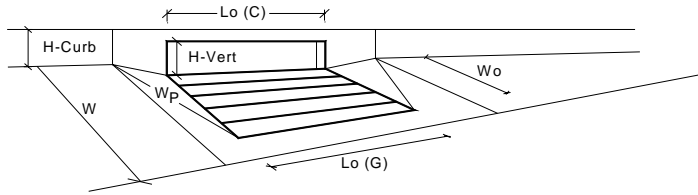

Design Information (Input)	MINOR	MAJOR	
Type of Inlet	CDOT/Denver 13 Valley Grate		
Local Depression (additional to continuous gutter depression 'a' from above)	2.00	2.00	inches
Number of Unit Inlets (Grate or Curb Opening)	1	1	
Water Depth at Flowline (outside of local depression)	4.0	6.0	inches
Grate Information	MINOR	MAJOR	<input checked="" type="checkbox"/> Override
Length of a Unit Grate	3.00	3.00	feet
Width of a Unit Grate	1.73	1.73	feet
Open Area Ratio for a Grate (typical values 0.15-0.90)	0.43	0.43	
Clogging Factor for a Single Grate (typical value 0.50 - 0.70)	0.50	0.50	
Grate Weir Coefficient (typical value 2.15 - 3.60)	3.30	3.30	
Grate Orifice Coefficient (typical value 0.60 - 0.80)	0.60	0.60	
Curb Opening Information	MINOR	MAJOR	
Length of a Unit Curb Opening	N/A	N/A	feet
Height of Vertical Curb Opening in Inches	N/A	N/A	inches
Height of Curb Orifice Throat in Inches	N/A	N/A	inches
Angle of Throat (see USDCM Figure ST-5)	N/A	N/A	degrees
Side Width for Depression Pan (typically the gutter width of 2 feet)	N/A	N/A	feet
Clogging Factor for a Single Curb Opening (typical value 0.10)	N/A	N/A	
Curb Opening Weir Coefficient (typical value 2.3-3.7)	N/A	N/A	
Curb Opening Orifice Coefficient (typical value 0.60 - 0.70)	N/A	N/A	
Low Head Performance Reduction (Calculated)	MINOR	MAJOR	
Depth for Grate Midwidth	0.36	0.52	ft
Depth for Curb Opening Weir Equation	N/A	N/A	ft
Grated Inlet Performance Reduction Factor for Long Inlets	0.63	0.94	
Curb Opening Performance Reduction Factor for Long Inlets	N/A	N/A	
Combination Inlet Performance Reduction Factor for Long Inlets	N/A	N/A	
Total Inlet Interception Capacity (assumes clogged condition)	1.0	2.6	cfs
Inlet Capacity IS GOOD for Minor and Major Storms (>Q Peak)	0.8	1.8	cfs

Appendix C: Drainage Map

Appendix D: Excerpts from “*Phase III Drainage Study for Boondocks Entertainment Facility*”

Circular Pipe Flow

Project: **Boondocks**

Pipe ID: **DP 13 to DP 16**

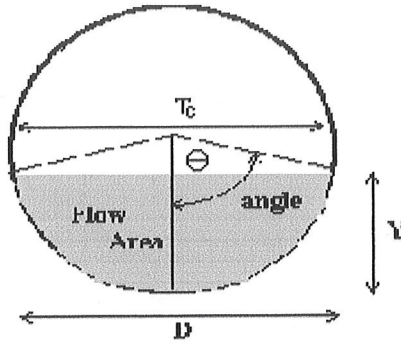

Design Information (Input)

Pipe Invert Slope	$S_o =$	0.0200 ft/ft
Pipe Manning's n-value	$n =$	0.0130
Pipe Diameter	$D =$	18.00 inches
Design discharge	$Q =$	13.8 cfs

Full-flow Capacity (Calculated)

Full-flow area	$A_f =$	1.77 sq ft
Full-flow wetted perimeter	$P_f =$	4.71 ft
Half Central Angle	$\text{Theta} =$	3.14 rad
Full-flow capacity	$Q_f =$	14.9 cfs

Calculation of Normal Flow Condition

Half Central Angle ($0 < \text{Theta} < 3.14$)	$\text{Theta} =$	2.12 rad
Flow area	$A_n =$	1.44 sq ft
Top width	$T_n =$	1.28 ft
Wetted perimeter	$P_n =$	3.18 ft
Flow depth	$Y_n =$	1.14 ft
Flow velocity	$V_n =$	9.57 fps
Discharge	$Q_n =$	13.8 cfs
Normal Depth Froude Number	$Fr_n =$	1.59

Calculation of Critical Flow Condition

Half Central Angle ($0 < \text{Theta-c} < 3.14$)	$\text{Theta-c} =$	2.56 rad
Critical flow area	$A_c =$	1.70 sq ft
Critical top width	$T_c =$	0.83 ft
Critical flow depth	$Y_c =$	1.38 ft
Critical flow velocity	$V_c =$	8.13 fps
Critical Depth Froude Number	$Fr_c =$	1.00

Use for Tailwater condition at downstream

D.11

Circular Pipe Flow

Project: **Boondocks**
 Pipe ID: **DP 11 to DP 12**

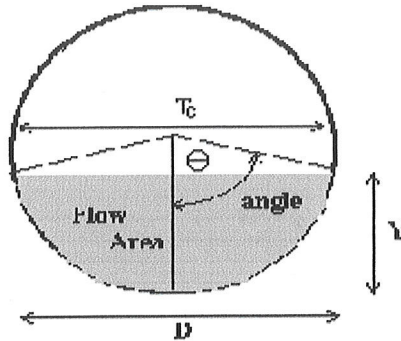

Design Information (Input)	
Pipe Invert Slope	$S_o = 0.0068$ ft/ft
Pipe Manning's n-value	$n = 0.0130$
Pipe Diameter	$D = 18.00$ inches
Design discharge	$Q = 8.6$ cfs
Full-flow Capacity (Calculated)	
Full-flow area	$A_f = 1.77$ sq ft
Full-flow wetted perimeter	$P_f = 4.71$ ft
Half Central Angle	$\theta = 3.14$ rad
Full-flow capacity	$Q_f = 8.7$ cfs
Calculation of Normal Flow Condition	
Half Central Angle ($0 < \theta < 3.14$)	$\theta = 2.24$ rad
Flow area	$A_n = 1.54$ sq ft
Top width	$T_n = 1.17$ ft
Wetted perimeter	$P_n = 3.36$ ft
Flow depth	$Y_n = 1.22$ ft
Flow velocity	$V_n = 5.60$ fps
Discharge	$Q_n = 8.6$ cfs
Normal Depth Froude Number	$Fr_n = 0.86$
Calculation of Critical Flow Condition	
Half Central Angle ($0 < \theta_c < 3.14$)	$\theta_c = 2.11$ rad
Critical flow area	$A_c = 1.44$ sq ft
Critical top width	$T_c = 1.29$ ft
Critical flow depth	$Y_c = 1.14$ ft
Critical flow velocity	$V_c = 5.99$ fps
Critical Depth Froude Number	$Fr_c = 1.00$

Ex. 100-Year Flow to S-6 MH

0.8

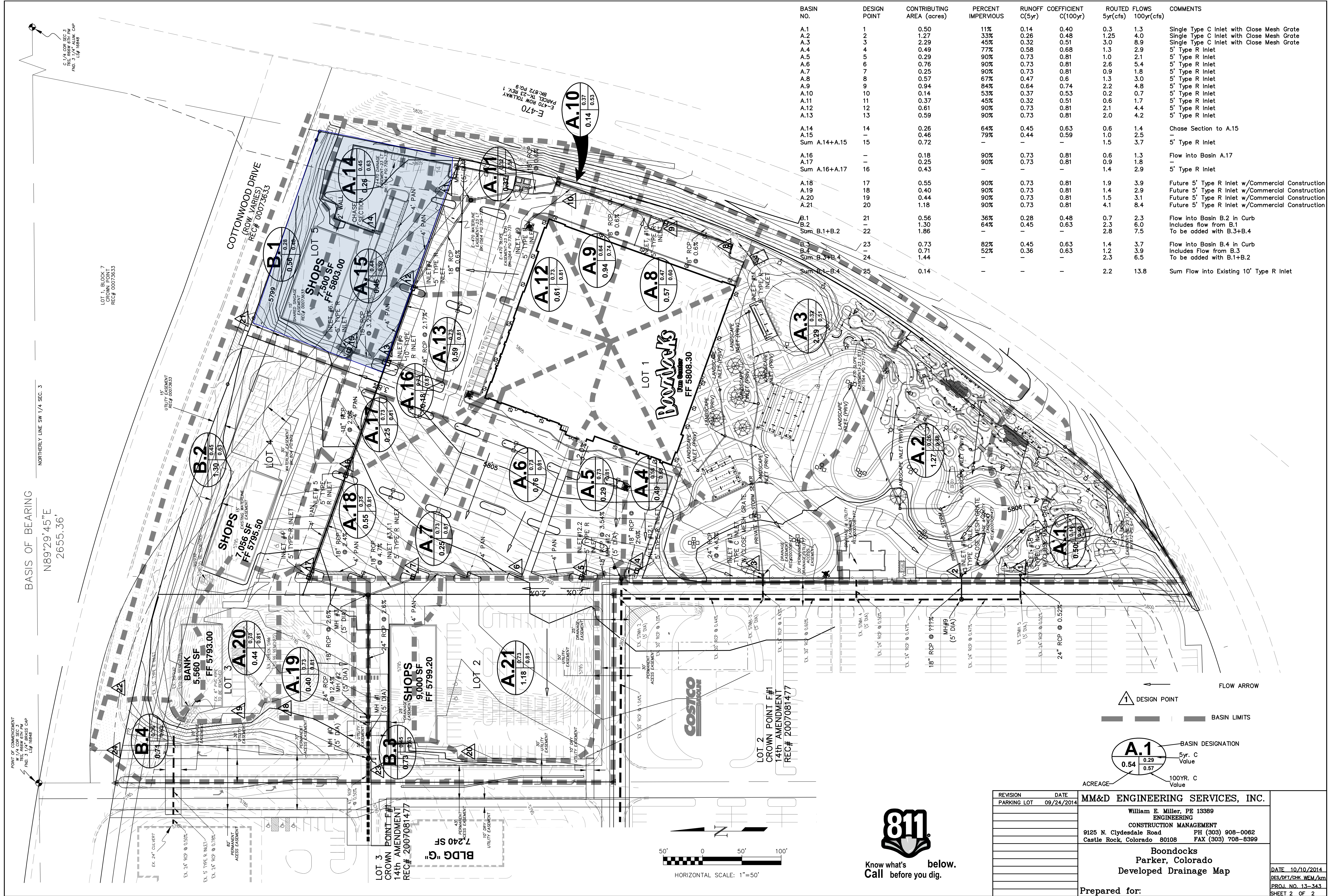

BASIN NO.	DESIGN POINT	CONTRIBUTING AREA (acres)	PERCENT IMPERVIOUS	RUNOFF COEFFICIENT C(5yr)	COEFFICIENT C(100yr)	ROUTED FLOWS 5yr(cfs)	FLOWS 100yr(cfs)	COMMENTS
A.1	1	0.50	11%	0.14	0.40	0.3	1.3	Single Type C Inlet with Close Mesh Grate
A.2	2	1.27	33%	0.26	0.48	1.25	4.0	Single Type C Inlet with Close Mesh Grate
A.3	3	2.29	45%	0.32	0.51	3.0	8.9	Single Type C Inlet with Close Mesh Grate
A.4	4	0.49	77%	0.58	0.68	1.3	2.9	5' Type R Inlet
A.5	5	0.29	90%	0.73	0.81	1.0	2.1	5' Type R Inlet
A.6	6	0.76	90%	0.73	0.81	2.6	5.4	5' Type R Inlet
A.7	7	0.25	90%	0.73	0.81	0.9	1.8	5' Type R Inlet
A.8	8	0.57	67%	0.47	0.6	1.3	3.0	5' Type R Inlet
A.9	9	0.94	84%	0.64	0.74	2.2	4.8	5' Type R Inlet
A.10	10	0.14	53%	0.37	0.53	0.2	0.7	5' Type R Inlet
A.11	11	0.37	45%	0.32	0.51	0.6	1.7	5' Type R Inlet
A.12	12	0.61	90%	0.73	0.81	2.1	4.4	5' Type R Inlet
A.13	13	0.59	90%	0.73	0.81	2.0	4.2	5' Type R Inlet
A.14	14	0.26	64%	0.45	0.63	0.6	1.4	Chase Section to A.15
A.15	15	0.46	79%	0.44	0.59	1.0	2.5	-
Sum A.14+A.15	15	0.72	-	-	-	1.5	3.7	5' Type R Inlet
A.16	16	0.18	90%	0.73	0.81	0.6	1.3	Flow into Basin A.17
A.17	17	0.25	90%	0.73	0.81	0.9	1.8	-
Sum A.16+A.17	16	0.43	-	-	-	1.4	2.9	5' Type R Inlet
A.18	18	0.55	90%	0.73	0.81	1.9	3.9	Future 5' Type R Inlet w/Commercial Construction
A.19	19	0.40	90%	0.73	0.81	1.4	2.9	Future 5' Type R Inlet w/Commercial Construction
A.20	20	0.44	90%	0.73	0.81	1.5	3.1	Future 5' Type R Inlet w/Commercial Construction
A.21	21	1.18	90%	0.73	0.81	4.1	8.4	Future 5' Type R Inlet w/Commercial Construction
B.1	21	0.56	36%	0.28	0.48	0.7	2.3	Flow into Basin B.2 in Curb
B.2	22	1.30	64%	0.45	0.63	2.3	6.0	Includes flow from B.1
Sum B.1+B.2	22	1.86	-	-	-	2.8	7.5	To be added with B.3+B.4
B.3	23	0.73	82%	0.45	0.63	1.4	3.7	Flow into Basin B.4 in Curb
B.4	24	0.71	52%	0.36	0.63	1.2	3.9	Includes Flow from B.3
Sum B.3+B.4	24	1.44	-	-	-	2.3	6.5	To be added with B.1+B.2
Sum B.1-B.4	25	0.14	-	-	-	2.2	13.8	Sum Flow into Existing 10' Type R Inlet

BASIS OF BEARING
N89°29'45"E
2655.36'

NORTHERLY LINE SW 1/4 SEC. 3

POINT OF COMMENCEMENT
TIES FROM 6TH PM
PND. 3 L&P 1884S

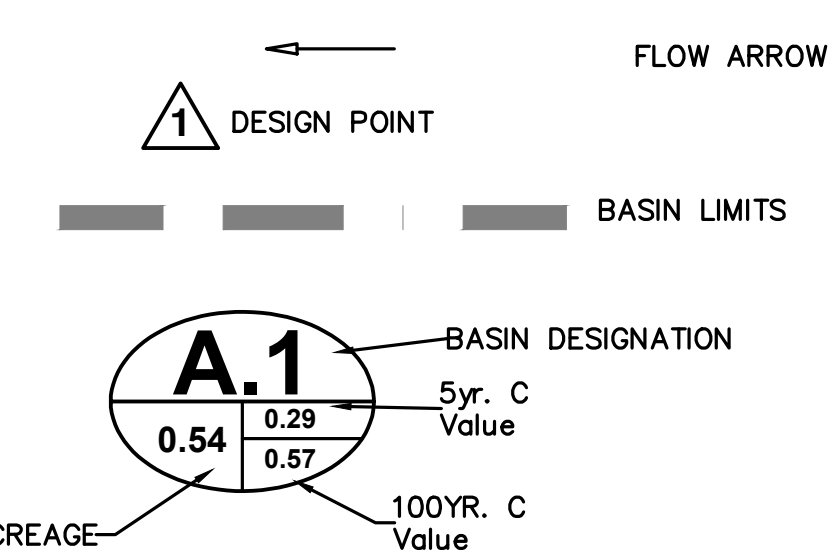
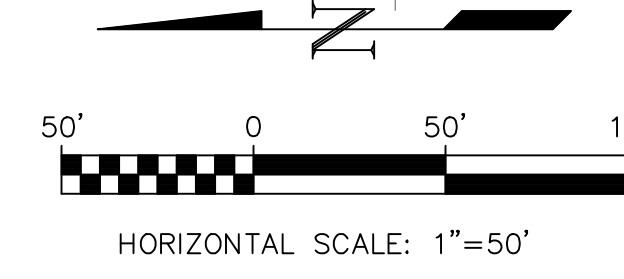

REVISION	DATE	MM&D ENGINEERING SERVICES, INC.
PARKING LOT	09/24/2014	
		William E. Miller, PE 13389 ENGINEERING CONSTRUCTION MANAGEMENT 9125 N. Clydesdale Road PH (303) 908-0062 Castle Rock, Colorado 80108 FAX (303) 708-8399
		Boondocks Parker, Colorado Developed Drainage Map
Prepared for:		DATE 10/10/2014 DES/DF/CHK WEM/km PROJ. NO. 13-343 SHEET 2 OF 2

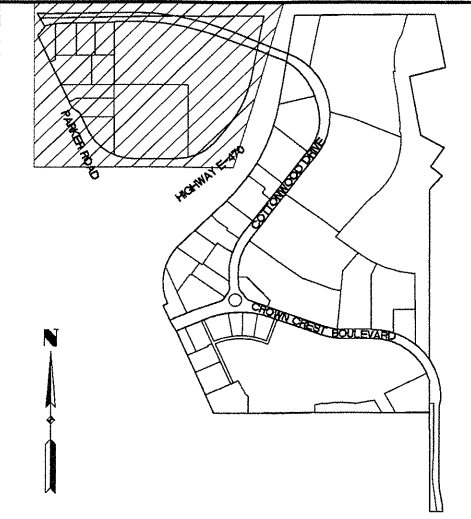
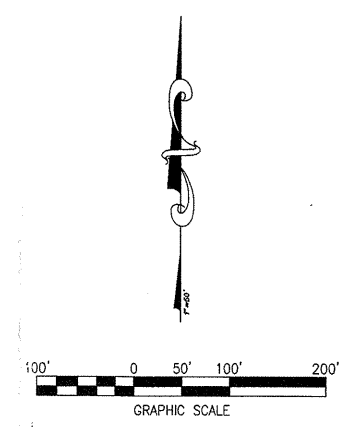
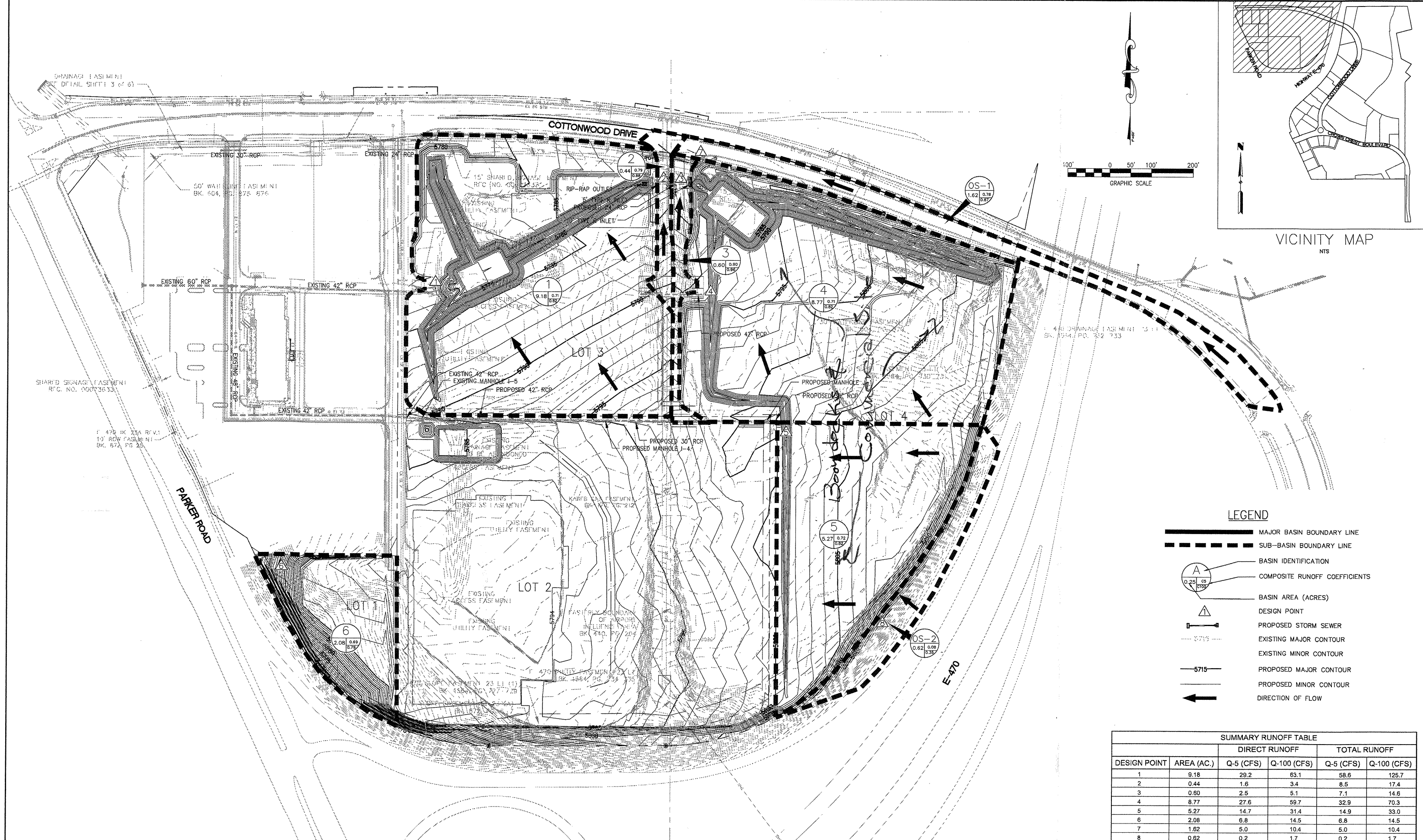

VICINITY MAP
NTS

LEGEND

- MAJOR BASIN BOUNDARY LINE
- SUB-BASIN BOUNDARY LINE
- BASIN IDENTIFICATION
- COMPOSITE RUNOFF COEFFICIENTS
- BASIN AREA (ACRES)
- DESIGN POINT
- PROPOSED STORM SEWER
- EXISTING MAJOR CONTOUR
- EXISTING MINOR CONTOUR
- PROPOSED MAJOR CONTOUR
- PROPOSED MINOR CONTOUR
- DIRECTION OF FLOW

DESIGN POINT	AREA (AC.)	DIRECT RUNOFF		TOTAL RUNOFF	
		Q-5 (CFS)	Q-100 (CFS)	Q-5 (CFS)	Q-100 (CFS)
1	9.18	29.2	63.1	58.6	125.7
2	0.44	1.6	3.4	8.5	17.4
3	0.60	2.5	5.1	7.1	14.6
4	8.77	27.6	59.7	32.9	70.3
5	5.27	14.7	31.4	14.9	33.0
6	2.08	6.8	14.5	6.8	14.5
7	1.62	5.0	10.4	5.0	10.4
8	0.62	0.2	1.7	0.2	1.7

1	PER TOWN OF PARKER COMMENTS	7-20-07	SPH	BJP
REV	REVISION DESCRIPTION	DATE	CHANGED BY	CHECKED BY

MERRICK
Engineers & Architects

2450 S. Peoria St., Aurora CO 80014, Phone 303/781-0741

TIM LEONARD
MAIL: P.O. BOX 1175 KITTREDGE, CO 80457
DELIVERIES: 27905 MEADOW DR., STE. 11
EVERGREEN, CO 80439
PHONE: (303) 674-7856
FAX: (303) 674-2254

MERRICK	SIGNATURE	DATE
DRAWN	CAW	07/20/07
DESIGNED	CAW	07/20/07
QC REVIEW	GAC	07/20/07
APPROVED	BJP	07/20/07
CLIENT	SIGNATURE	DATE
REVIEW		
APPROVED		
CAD FILE NAME	3841-DRN	

TODAY CROWN POINT
CROWN POINT #1, 14111 AMTNDMNT
PARKTR, COLORADO

CLIENT PROJECT NO.
MERRICK PROJECT NO. 030-3841

SCALE: 1" = 100'

TITLE:
**14TH AMENDMENT
CONSTRUCTION PLANS
DRAINAGE MAP
FUTURE**

REVISION: DRAWING NO. LATEST DATE: SHEET NO.
07/20/07

F:\ACI\1801881\Drawings\14th Amendment Final Drainage\3841-DRN-Future.dwg, FINAL, 12/27/2007 11:21:55 AM, cvelazquez, Adobe PDF, 1:1