





















# CROWN POINT FILING NO.1 LOT 4E

LOCATED IN THE SOUTHWEST QUARTER OF SECTION 3, TOWNSHIP 6 SOUTH,  
RANGE 66 WEST OF THE 6TH PRINCIPAL MERIDIAN,  
CITY OF PARKER, COUNTY OF DOUGLAS, STATE OF COLORADO

## SITE PLAN DOCUMENTS

NOVEMBER 2024

**COPYRIGHT**  
THESE PLANS ARE AN INSTRUMENT OF SERVICE AND ARE THE PROPERTY OF GALLOWAY, AND MAY NOT BE DUPLICATED, DISCLOSED, OR REPRODUCED WITHOUT THE WRITTEN CONSENT OF GALLOWAY. COPYRIGHTS AND INFRINGEMENTS WILL BE ENFORCED AND PROSECUTED.



LAND OF SUSHI  
CROWN POINT FILING NO. 1  
AMD 20, LOT 4E

18704 COTTONWOOD DR.  
PARKER, COLORADO 80138

#	Date	Issue / Description	Init.
1	8/30/24	4TH SUBMITTAL	EDN
2			
3			
4			
5			
6			
7			
8			
9			
10			
11			
12			

Project No:	LOS000001
Drawn By:	TDN
Checked By:	TDN
Date:	11/27/2024

IRRIGATION DETAILS

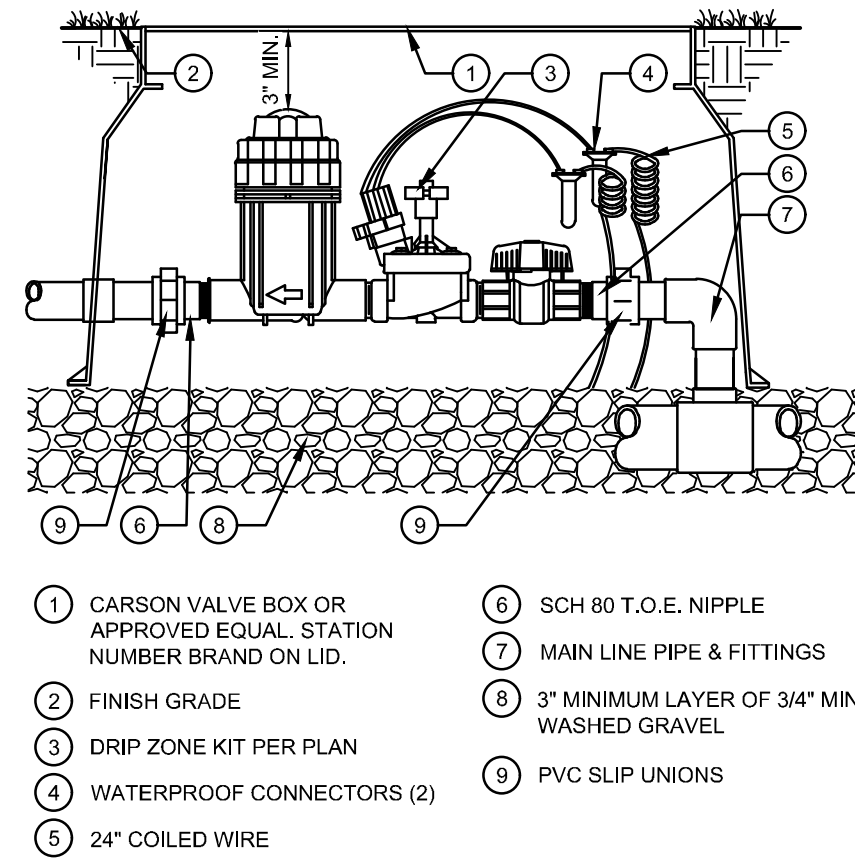

- 1 CARSON VALVE BOX OR APPROVED EQUAL. STATION NUMBER BRAND ON LID.
- 2 FINISH GRADE
- 3 DRIP ZONE KIT PER PLAN
- 4 WATERPROOF CONNECTORS (2)
- 5 24" COILED WIRE
- 6 SCH 80 T.O.E. NIPPLE
- 7 MAIN LINE PIPE & FITTINGS
- 8 3" MINIMUM LAYER OF 3/4" MINUS WASHED GRAVEL
- 9 PVC SLIP UNIONS

1 REMOTE DRIP CONTROL VALVE  
N.T.S.

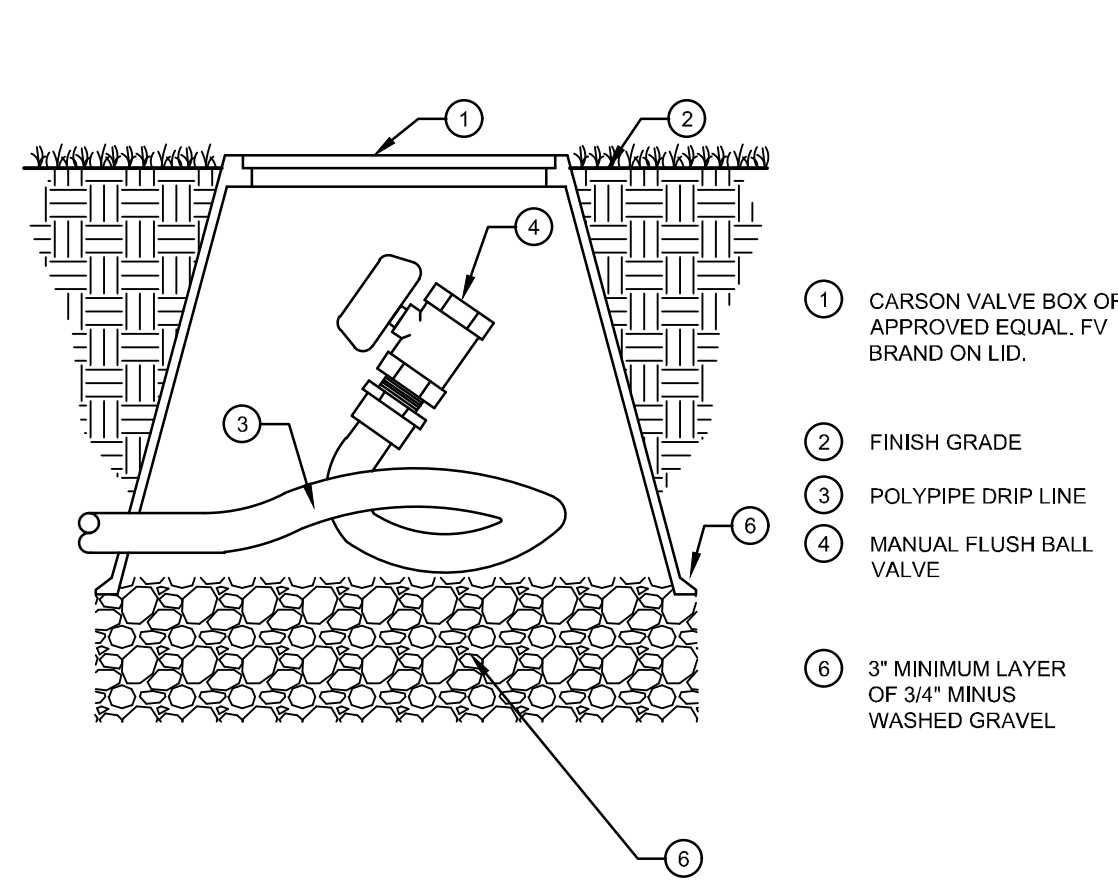

- 1 CARSON VALVE BOX OR APPROVED EQUAL. FV BRAND ON LID.
- 2 FINISH GRADE
- 3 POLYPIPE DRIP LINE
- 4 MANUAL FLUSH BALL VALVE
- 5 3" MINIMUM LAYER OF 3/4" MINUS WASHED GRAVEL

2 MANUAL FLUSH DRAIN VALVE  
N.T.S.

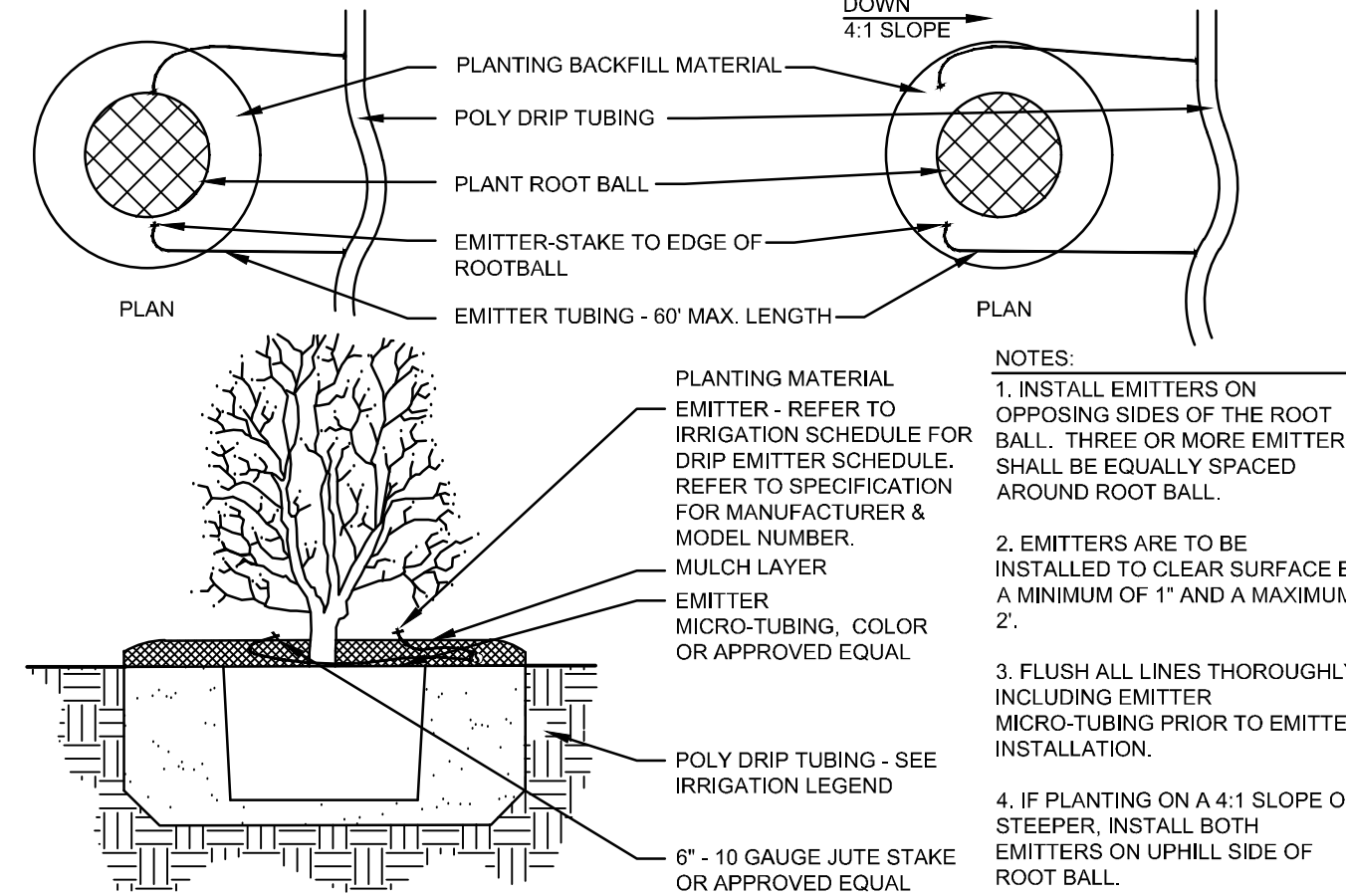

- 1 CARSON VALVE BOX OR APPROVED EQUAL. FV BRAND ON LID.
  - 2 FINISH GRADE
  - 3 POLYPIPE DRIP LINE
  - 4 MANUAL FLUSH BALL VALVE
  - 5 3" MINIMUM LAYER OF 3/4" MINUS WASHED GRAVEL
- PLANTING BACKFILL MATERIAL  
POLY DRIP TUBING  
PLANT ROOT BALL  
EMITTER-STAKE TO EDGE OF ROOTBALL  
EMITTER TUBING - 60" MAX. LENGTH
- PLANTING MATERIAL  
EMITTER - REFER TO IRRIGATION SCHEDULE FOR DRIP EMITTER SCHEDULE. REFER TO SPECIFICATION FOR MANUFACTURER & MODEL NUMBER.  
MULCH LAYER  
EMITTER MICRO-TUBING, COLOR OR APPROVED EQUAL.  
POLY DRIP TUBING - SEE IRRIGATION LEGEND  
6" - 10 GAUGE JUTE STAKE OR APPROVED EQUAL
- NOTES:  
1. INSTALL EMITTERS ON OPPOSING SIDES OF THE ROOT BALL. THREE OR MORE EMITTERS SHALL BE EQUALLY SPACED AROUND ROOT BALL.  
2. EMITTERS ARE TO BE INSTALLED TO CLEAR SURFACE BY A MINIMUM OF 1" AND A MAXIMUM 2".  
3. FLUSH ALL LINES THOROUGHLY, INCLUDING EMITTER MICRO-TUBING PRIOR TO EMITTER INSTALLATION.  
4. IF PLANTING ON A 4:1 SLOPE OR STEEPER, INSTALL BOTH EMITTERS ON UPHILL SIDE OF ROOT BALL.  
5. EMITTERS SHALL BE SELF-FLUSHING, PRESSURE COMPENSATING-TYPE UNLESS NOTED OTHERWISE WITHIN TECHNICAL SPECIFICATIONS.

3 DRIP EMITTERS LAYOUT  
N.T.S.

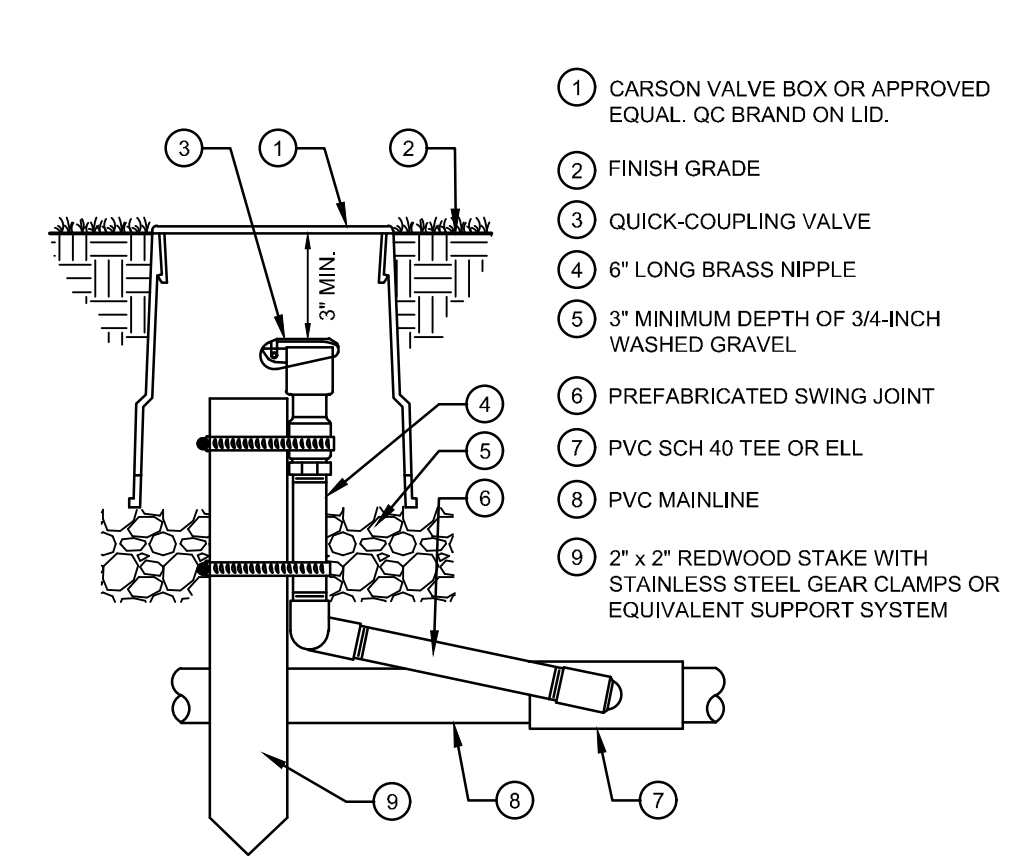

- 1 CARSON VALVE BOX OR APPROVED EQUAL. QC BRAND ON LID.
- 2 FINISH GRADE
- 3 QUICK-COUPLING VALVE
- 4 6" LONG BRASS NIPPLE
- 5 3" MINIMUM DEPTH OF 3/4-INCH WASHED GRAVEL
- 6 PREFABRICATED SWING JOINT
- 7 PVC SCH 40 TEE OR ELL
- 8 PVC MAINLINE
- 9 2" x 2" REDWOOD STAKE WITH STAINLESS STEEL GEAR CLAMPS OR EQUIVALENT SUPPORT SYSTEM

4 QUICK COUPLER  
N.T.S.

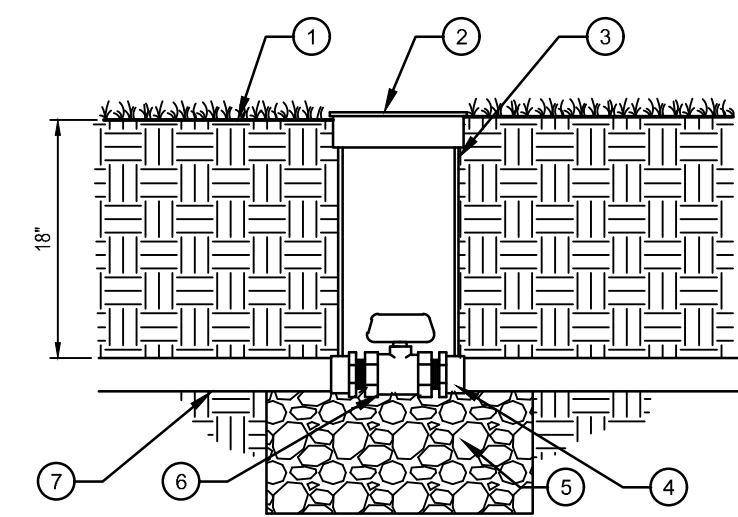

- 1 FINISH GRADE AT 1" BELOW TOP OF BOX IN TURF AREAS; 2" BELOW TOP OF BOX IN SHRUB/GROUNDCOVER AREAS
- 2 CARSON VALVE BOX OR APPROVED EQUAL. BV BRAND ON LID.
- 3 EXTENSION SECTION AS NECESSARY TO MEET GRADE
- 4 PVC MALE ADAPTER
- 5 3" MINIMUM LAYER OF 3/4" MINUS WASHED GRAVEL
- 6 PLASTIC BALL VALVE (SIZED PER MAINLINE)
- 7 IRRIGATION MAINLINE

5 BALL VALVE  
N.T.S.

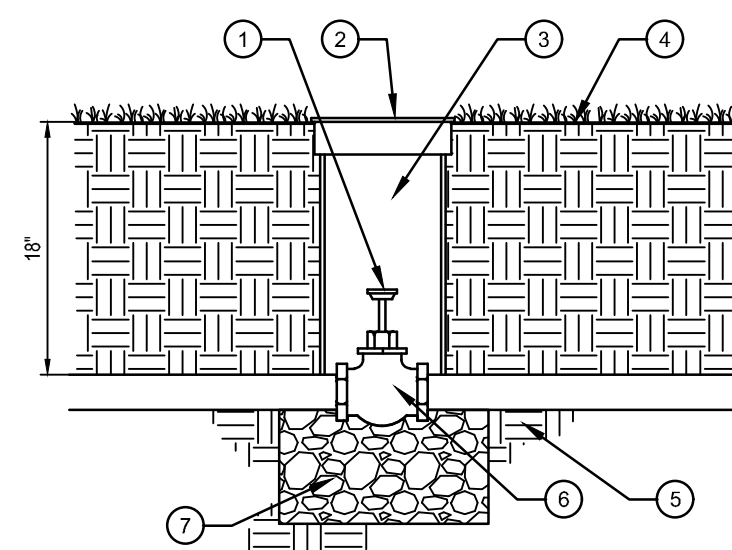

- 1 KEY HEAD PER HEAD
- 2 CARSON VALVE BOX OR APPROVED EQUAL.
- 3 4" PVC SLEEVE
- 4 FINISH GRADE AT 1" BELOW TOP OF BOX IN TURF AREAS; 2" BELOW TOP OF BOX IN SHRUB/GROUNDCOVER AREAS
- 5 IRRIGATION MAINLINE
- 6 GATE VALVE (SIZED PER MAINLINE)
- 7 3" MINIMUM LAYER OF 3/4" MINUS WASHED GRAVEL

6 GATE VALVE  
N.T.S.

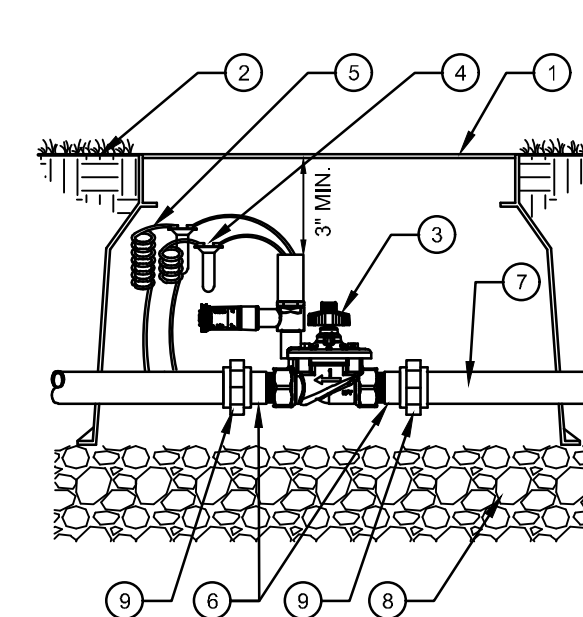

- 1 CARSON VALVE BOX OR APPROVED EQUAL. MV BRAND ON LID.
- 2 FINISH GRADE
- 3 REMOTE CONTROL VALVE
- 4 WATERPROOF CONNECTORS (2)
- 5 24" COILED WIRE
- 6 SCH 80 T.O.E. NIPPLE
- 7 MAINLINE PIPE & FITTINGS
- 8 3/4" MINUS WASHED GRAVEL
- 9 PVC SLIP UNIONS

7 MASTER VALVE  
N.T.S.

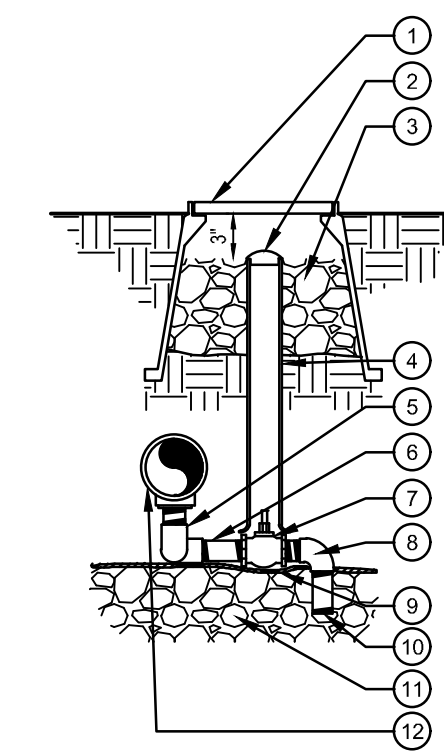

- 1 CARSON VALVE BOX OR APPROVED EQUAL. DV BRAND ON LID.
- 2 2" VALVE MARKER
- 3 3/4" CRUSHED GRAVEL SUMP 1 CU. FT.
- 4 2" CL160 PVC ACCESS SLEEVE - LENGTH AS REQUIRED
- 5 3/4" Fx F SCH. 80 PVC 90 ELL (2)
- 6 3/4"xCL PVC NIPPLE SCH. 80 (2)
- 7 3/4"x6" SCH. 80 GALVANIZED STEEL NIPPLE
- 8 3/4" Mx F SCH. 40 PVC 90 ELL
- 9 SOIL BLANKET COVERING SUMP
- 10 3/4"x4" PVC NIPPLE SCH. 80
- 11 3/4" CRUSHED GRAVEL SUMP SEE TECHNICAL SPECIFICATIONS FOR SUMP SIZE
- 12 PRESSURE MAINLINE

8 MANUAL DRAIN VALVE  
N.T.S.

