



GENERAL NOTES

- A. PHOTOMETRIC CALCULATIONS DO NOT INCLUDE CONTRIBUTION FROM STREET LIGHTING OR LIGHTING FROM ADJACENT PROPERTY.
- B. ALL FIXTURES SHALL BE FULL CUTOFF AND MOUNTED IN FULL CUTOFF POSITION. ALL SITE POLES SHALL BE ROUND AND PAINTED IN A DARK, NON-REFLECTIVE COLOR.

LEGEND

- POLE MOUNTED LIGHT
- WALL MOUNTED LIGHT
- RECESSED CAN LIGHT

SITE LIGHTING SCHEDULE										
FIXTURES										
TYPE	DESCRIPTION	MANUFACTURER	CATALOG NUMBER	NOTES	VOLTS	LUMENS	WATTS	HEIGHT	MOUNTING	LAMP
D3E	6.2' WET LOCATION RECESSED DOWNLIGHT WITH REMOTE EMERGENCY BATTERY	ZUMTOBEL	PNR02-DN-150-RL-11W-830-CB-W-E-1500L-R-11W-5A-11 BOONE SS, TC22TU		2	120	1,848	11	RECESSED	12' LED, 3500K
S1	LED POLE MOUNTED FIXTURE, TWIN HEAD @ 180 DEGREE, TYPE 3 DISTRIBUTION WITH SPILL CONTROL, AND MOTION SENSOR CONTROLLED DIMMING	MCGRAW EDISON	GLEON-SA1E-740-U-SL3-BZ-FF-MSDIM-L40W		1, 2, 3	208	5,985 / 11,070	44 / 88	POLE	20' LED, 4000K
S201E	ROUND STRAIGHT STEEL POLE, DARK BRONZE, 20' MOUNTING HEIGHT	MCGRAW EDISON	RSSxxxxS-F-14-2-X-G		1, 4					
W1E	LED WALL MOUNTED FIXTURE, FULL CUTOFF, DARK BRONZE FINISH WITH MOTION SENSOR AND DIMMING, PROVIDE BATTERY BACKUP WHERE LABELED 'W1E'	MCGRAW EDISON	ST-SA1E-740-U-SL2-BZ-CBP-MSDIM-L20		1, 2	120	7,060	50	WALL	14' LED, 4000K
W2	LED WALL MOUNTED FIXTURE, FULL CUTOFF, DARK BRONZE FINISH	MCGRAW EDISON	ST-SA1E-740-U-SL2-BZ-MSDIM-L20		1, 2	120	5,846	45	WALL	12' LED, 4000K

- NOTES:
- COLOR SHALL BE DARK BRONZE. VERIFY FIXTURES AND POLES HAVE MATCHING FINISH.
 - FIXTURE SHALL BE CONTROLLED BY PROGRAMMABLE LIGHTING PANEL TO DISABLE OPERATION BETWEEN 11:00 PM AND 6:00 AM OR AS REQUIRED BY AHJ.
 - INSTALL FIXTURE HEAD WITH 0° TILT TO PROVIDE FULL-CUTOFF DISTRIBUTION (NO LIGHT OUTPUT EMITTED ABOVE 90 DEGREES AT ANY LATERAL ANGLE AROUND THE FIXTURE).
 - COORDINATE OVERALL POLE LENGTH WITH FACTORY TO PROVIDE 20' FIXTURE MOUNTING HEIGHT INCLUDING 4" CONCRETE BASE. PROVIDE POLE MPFS RECOMMENDED ANCHOR BOLTS.

PHOTOMETRIC STATISTICS - ILLUMINANCE IN FOOT-CANDLES						
(VALUES ARE CALCULATED USING VISUAL LIGHTING 2020 BY LITHONIA AND MANUFACTURER'S IES FILES)						
DESCRIPTION	SYMBOL	AVG	MAX	MIN	AVG/MIN	MAX/MIN
PARKING LOT AREA	+	1.6 fc	6.8 fc	0.8 fc	2.0:1	8.5:1

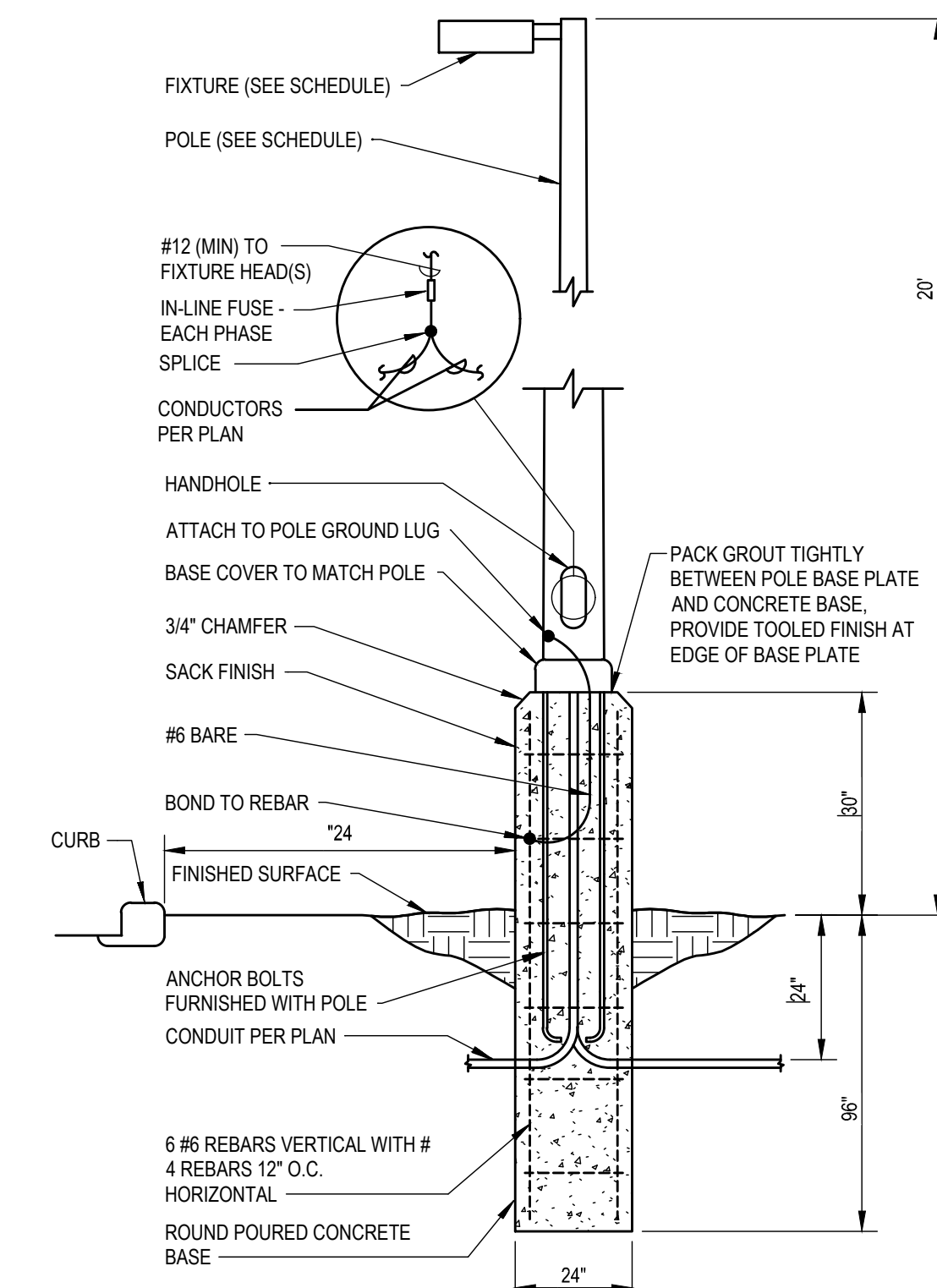
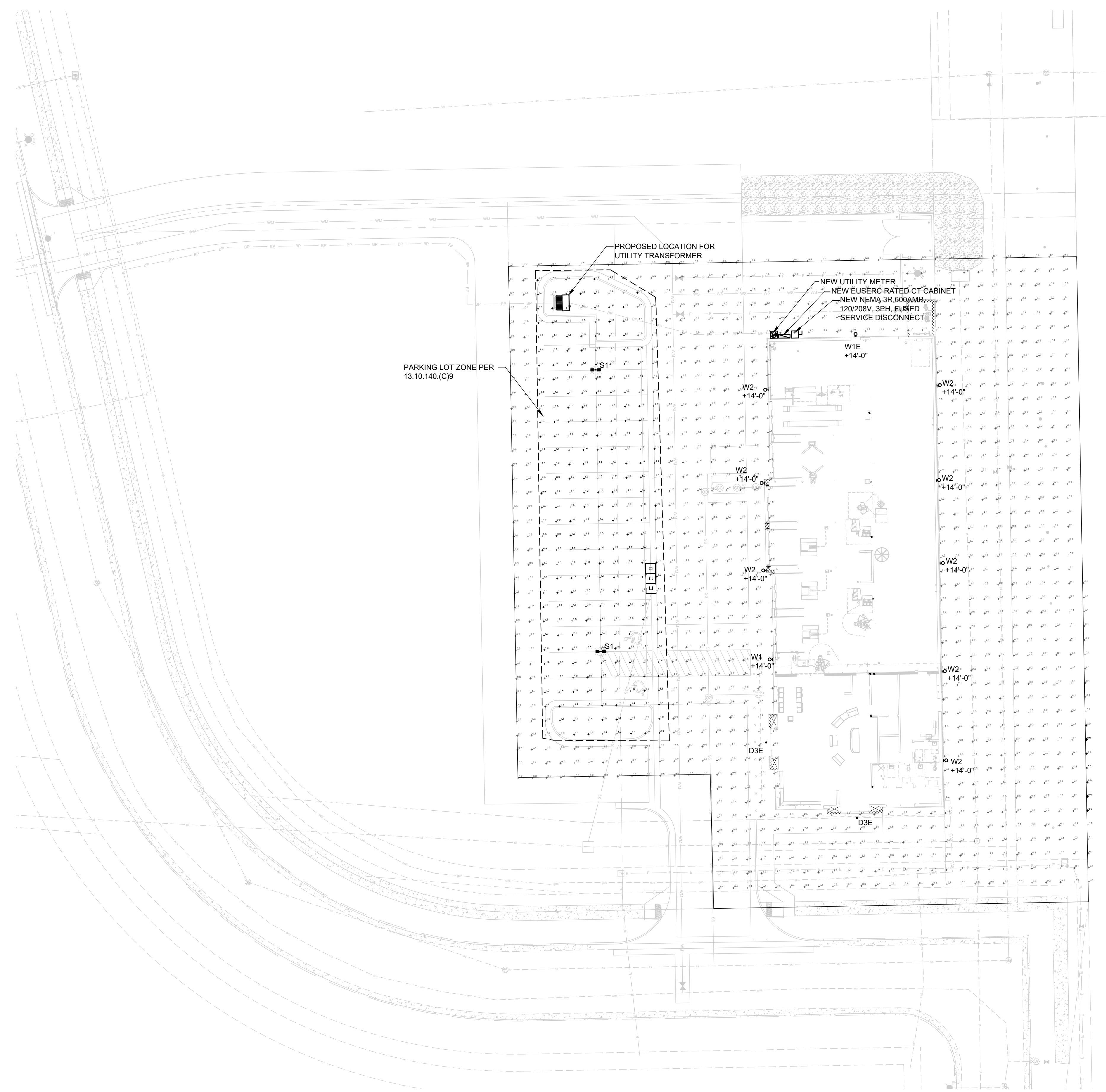

1 SITE PHOTOMETRIC PLAN
NORTH REF.
SCALE: 1" = 20'-0"

2 POLE DETAIL

NOT FOR CONSTRUCTION - PRELIMINARY DESIGN
 12236 SLICEROO DR, PARKER, CO
 6-BAY LINEAR STORE
LES SCHWAB TIRE CENTER - PARKER, CO
 © 2023 | ALL RIGHTS RESERVED
 CIVIL CDS
 07.11.2023
 DRAWN BY | GRAGG
 CHECKED BY | GRAGG
 REVISIONS
 SITE PHOTOMETRIC PLAN
E100