

AdventHealth Parker Expansion



May 31, 2023

Town of Parker
Engineering Development Review
20120 East Main Street
Parker, CO 80138

Denver
Cairo

RE: AdventHealth Parker Expansion

To whom it may concern,

Civil
Structural
Integrated Services

This letter serves as a Drainage Conformance Letter for the proposed AHP Expansion. This letter references the "Final Drainage and Erosion Control Report for the Parker Adventist Hospital", prepared by S. A. Miro, Inc., dated May 1, 2002. The latest update to the report was for the Medical Office Building III, prepared by S. A. Miro, Inc., dated November 2018.

The purpose of this letter is to demonstrate the existing and proposed storm sewer facilities serving the improvements for the existing hospital site can adequately convey, treat, and detain the runoff generated by the proposed AHP Expansion. All runoff from the AHP Expansion is routed through existing and proposed storm sewer facilities to the existing Southwest Pond A and South Pond B detention/water quality ponds.

I. PROJECT DESCRIPTION

Improvements that impact the storm sewer facilities are as follows:

- The construction of an expansion to the existing hospital, located south of the main hospital and east of the Bed Tower, with a footprint of 30,240 sq. ft.
- Proposed ambulance drop-off loop, relocation of the existing helipad, and (2) two additional fire lanes with an added impervious area of 43,117 sq. ft. (excludes existing impervious area being removed and replaced by pervious areas)
- An additional 9,761 sq. ft. of overhead canopies extending beyond the expansion's building footprint and a 2,100 sq. ft. facilities shed for a total proposed roof area 42,101 sq. ft.
- A total disturbed area of 119,181 sq. ft. (2.74 acres)
- The existing ponds have adequate volume to detain the additional flow generated from this development. The existing orifice restrictor plate will be replaced on both ponds to provide adequate water quality treatment.
- The addition of approximately 480 LF of proposed storm sewer pipe and several street inlets and trench drain.

The sub-basins that have been modified for these additions are the following, B7A, C3, C5, C7, C8, C9, DA7, DA9, DA10, DA12 and F6, with the addition of sub-basins G1 through G12.

The AdventHealth Parker (formerly identified as Parker Adventist Hospital) campus was master planned with the anticipation of the entire campus to be fully developed. While the proposed development is increasing imperviousness, it is still within the planned overall imperviousness. The existing storm infrastructure was sized with future development in mind and can convey increased flows to the South Pond B and Southwest Pond A. The proposed design is accounting for future development to be conveyed through the system as well. See the appendix for further information regarding storm sewer conveyance.

AdventHealth Parker Expansion

II. DRAINAGE FACILITY DESIGN

Detention/Water Quality

All proposed storm runoff will be conveyed via storm pipe and discharged to South Pond B and Southwest Pond A. The Ponds have been master planed to detain and treat the AdventHealth Parker site in a future, fully-developed condition, and has been confirmed to have the capacity to treat (with replacement of the existing orifice plates in both ponds) and detain the proposed improvements associated with the AHP Expansion. No grading revisions are proposed as the existing pond geometry has adequate volumetric capacity.

Storm Sewer Layout

The proposed storm sewer system will tie into the existing infrastructure at four (4) different locations. See the drainage plan for details on these connections.

- The total flow from the proposed development in the 100-yr storm event is:
 - 68 cfs to the Southwest Pond A
 - 23 cfs to the South Pond B
- The total flow from the existing impacted sub-basins prior to modification in the 100-yr storm event was:
 - 57 cfs to Southwest Pond A
 - 28 cfs to South Pond B
- The change in flow from the development in the 100-yr storm event is:
 - 11 cfs increase to Southwest Pond A
 - 5 cfs decrease to South Pond B

Proposed basin G2 is replacing existing basin DA12 which previously was being routed to South Pond B but is now being rerouted to Southwest Pond A. This rerouting along with the change in imperviousness for the areas tributary to each pond are the cause of the new incoming flow rates.

The proposed storm sewer was analyzed using the StormCAD V8i program to ensure that the added storm infrastructure does not overwhelm the existing system. The hydraulic grade lines are under the required 1-foot below finish grade at the manholes. The system was checked against flows in the 100-yr condition. Therefore, the existing and proposed storm sewer is expected to function adequately to convey the anticipated runoff flows. Storm sewer profiles including HGLs are included in the Appendix for reference.

III. CONCLUSIONS

Compliance with Standards

This Drainage Conformance Letter complies with the Town of Parker Storm Drainage and Environmental Criteria Manual, and the Urban Storm Drainage Criteria Manual. The drainage system is designed to efficiently intercept runoff in curb and gutter and storm sewer and convey the flows to the existing Southwest Pond A and South Pond B detention/water quality ponds. The site provides a drainage system which does not exceed the allowable capacities of the existing storm sewer/drainage facilities.

Please call us if you have any questions.

Sincerely,
Megan Huerter Vogt, P.E.
Senior Associate

AdventHealth Parker Expansion

IV. APPENDICES

- a. HYDROLOGIC CRITERIA**
- b. HYDROLOGIC CALCULATIONS**
- c. HYDRAULIC CALCULATIONS**
- d. MAPS**

AdventHealth Parker Expansion

Appendix A Hydrologic Criteria

5. HYDROLOGIC CRITERIA

5.1 INTRODUCTION

This section presents the criteria and methodology for determining storm runoff design peaks and volumes to be used in the Town of Parker for preparation of storm drainage plans and facility design. In general, hydrologic analysis of the initial and major storm events for both the historic and fully developed site conditions is required. In addition to the hydrologic analysis for a site, a hydrologic analysis should be performed for all off site basins that impact the proposed site. The Town of Parker adopts procedures prescribed by the Urban Drainage and Flood Control District (UDFCD) for performing hydrologic analysis. These procedures may be found in the Rainfall and Runoff sections of the MANUAL. Standards and technical criteria found in the MANUAL should be followed except where superseded by specific requirements of this manual.

5.2 DESIGN RAINFALL

For any storm runoff technique, design rainfall must first be established. The design rainfall data to be used for the Town of Parker were obtained from NOAA Atlas 2, Precipitation– Frequency Atlas of the Western United States, Volume III– Colorado. The design storm events developed and utilized are the same as those used by UDFCD.

The one-hour point rainfall depths for different frequency events are shown in Table 5.1 herein. Rainfall intensity as a function of the one-hour point rainfall and the time of concentration can be approximated by the following equation which appears in the MANUAL as Equation RA-5.

$$I = (28.5P_1)/(10+t_c)^{0.786}$$

Where, I = rainfall intensity (in/hr)
 P₁ = one-hour point rainfall depth (in)
 t_c = time of concentration (min)

Graphical presentation of the equation is shown as the Time-Intensity-Frequency curves in Figure 5.1 herein. Rainfall intensity for use in the Rational Method may be taken from Figure 5.1 or calculated using the equation.

Frequency of Design Event (yr)	One-hour Point Rainfall, P ₁ (in)
2	0.99
5	1.39
10	1.64
25	1.98
50	2.31
100	2.60

5.3 FLOOD HYDROLOGY OVERVIEW

Various methods exist to determine appropriate flood peaks or hydrographs for storm drainage planning and design. Methods for determining flood peaks or hydrographs are the Rational Method, the Colorado Urban Hydrograph Procedure (CUHP), and Urban Drainage Stormwater Management (UDSWM) model. The Town of Parker discourages the use of computer models other than CUHP and UDSWM since these programs are preferred, if not required, by UDFCD for studies involving major drainageways where UDFCD approval is sought or where maintenance eligibility is requested.

The three methods are briefly described in this section, and a discussion of their applicability to the Town of Parker is discussed. UDSWM is mostly used to combine and route the hydrographs generated using CUHP.

In general, the Rational Method is the most widely used and accepted technique for determining peak flows in urban areas for small basins. Within the constraints outlined in the MANUAL, use of the Rational Method provides a relatively simple but effective way to analyze storm runoff.

CUHP is somewhat more complicated than the Rational Method. It allows a manual computation of a runoff hydrograph which may be used for further hydraulic routing through channels and/or detention ponds. Historically, CUHP is best used in urban areas for which runoff coefficients have been derived. However, recent improvements by UDFCD include consideration for different soil types, thus CUHP is now more applicable to rural areas. The reader is referred to UDFCD for the latest version of CUHP.

UDSWM is a computer model that generates runoff hydrographs and routes and combines these hydrographs. UDSWM is a modified version of the Runoff Block of the Environmental Protection Agency's Storm Water Management Model (SWMM). It has been modified to be used in conjunction with CUHP. Table 5.2 herein provides guidance on selecting the appropriate method for a given project.

AdventHealth Parker Expansion

Appendix B Hydrologic Calculations



Composite C Calculations

Project Information
 Project Name: AHP Expansion
 Miro Project No: 23-079
 Revised Date: 5/30/2024
 Calculated By: RJH

Jurisdiction Impervious Value
 Pond Area 100%
 Landscape Area 2%
 Paved Area 100%
 Roof Area 90%

Coefficient Equations
 $C_{CD(2)} = 0.83i + 1.122$
 $C_{CD(5)} = 0.82i + 0.035$
 $C_{CD(10)} = 0.74i + 0.132$
 $C_{CD(100)} = 0.4i + 0.484$

*NOTE: C_{CD} Equations from UDFCD Criteria Manual updated March 2017

Basin Designation	A _{pond} (ft ²)	A _{landscape} (ft ²)	A _{paved} (ft ²)	A _{roof} (ft ²)	A _{total} (acres)	Imperviousness	C _{CD} 02 yr	C _{CD} 05 yr	C _{CD} 10 yr	C _{CD} 100 yr
G1	0	3,575	7,502	0	0.25	68%	0.54	0.60	0.64	0.76
G2	0	1,909	13,030	297	0.35	88%	0.71	0.75	0.78	0.83
G3	0	0	0	21,963	0.50	90%	0.74	0.77	0.80	0.84
G4	0	9,466	9,576	0	0.44	51%	0.39	0.46	0.51	0.69
G5	0	0	0	18,038	0.41	90%	0.74	0.77	0.80	0.84
G6	0	0	6,346	0	0.15	100%	0.83	0.86	0.87	0.88
G7	0	30,859	57,729	1,345	2.06	66%	0.52	0.58	0.62	0.75
G8	0	1,500	15,079	0	0.38	91%	0.75	0.78	0.81	0.85
G9	0	801	12,404	0	0.30	94%	0.77	0.81	0.83	0.86
G10	0	0	0	2,100	0.05	90%	0.74	0.77	0.80	0.84
G11	0	3,455	6,772	0	0.23	67%	0.53	0.58	0.63	0.75
G12	0	20,277	70,430	0	2.08	78%	0.63	0.68	0.71	0.80
					0.00					
E1				23,473	0.54	90%	0.74	0.77	0.80	0.84
E2		23,244			0.53	2%	0.01	0.05	0.15	0.49
E3		2,562	6,608		0.21	73%	0.58	0.63	0.67	0.77
E4		4,010	10,513		0.33	73%	0.58	0.63	0.67	0.78
E5		4,799	11,708		0.38	72%	0.57	0.62	0.66	0.77
E6		11,551			0.27	2%	0.01	0.05	0.15	0.49
E7		12,542	18,703		0.72	61%	0.47	0.53	0.58	0.73
E8		1,360	3,183		0.10	71%	0.56	0.61	0.65	0.77
E9		1,971	25,406		0.63	93%	0.76	0.80	0.82	0.86
E10		2,585	19,070		0.50	88%	0.72	0.76	0.79	0.84
E11		917	26,635		0.63	97%	0.80	0.83	0.85	0.87
E12			16,075		0.37	100%	0.83	0.86	0.87	0.88
E13		1,748	10,475		0.28	86%	0.70	0.74	0.77	0.83
E14		735	20,646		0.49	97%	0.80	0.83	0.85	0.87
E15		9,837	5,494		0.35	37%	0.27	0.34	0.41	0.63
F1		82,679			1.90	2%	0.01	0.05	0.15	0.49
MOB III TOTAL		160,540	174,516	23,473	8.23	55%	0.43	0.49	0.54	0.71
					0.00					
*A1					4.61	67%	0.53	0.58	0.63	0.75
*A2					0.71	52%	0.40	0.46	0.52	0.69
*A3					0.32	2%	0.01	0.05	0.15	0.49
A4		7131	515		0.18	9%	0.05	0.11	0.20	0.52
A5		5045	15105		0.46	75%	0.61	0.65	0.69	0.79
B1#					1.20	80%	0.65	0.69	0.72	0.80
B1A#					0.14	80%	0.65	0.69	0.72	0.80
B2#					0.82	85%	0.69	0.73	0.76	0.82
B2A#					0.73	79%	0.64	0.68	0.72	0.80
B2B#					1.15	85%	0.69	0.73	0.76	0.82
B3***					0.73	67%	0.53	0.58	0.63	0.75
B3-1***					0.03	0%	0.00	0.04	0.13	0.48
B3-2***					0.14	60%	0.47	0.53	0.58	0.72
B4***					1.24	100%	0.83	0.86	0.87	0.88
B5***					0.55	72%	0.57	0.63	0.66	0.77
B5A***					0.10	89%	0.73	0.76	0.79	0.84
B5B***					0.20	80%	0.65	0.69	0.72	0.80
B5C***					0.08	88%	0.72	0.76	0.78	0.84
B6A(EX)**					0.67	78%	0.63	0.67	0.71	0.80
B6B(EX)					0.53	87%	0.71	0.75	0.78	0.83
B6C**					0.03	82%	0.66	0.71	0.74	0.81
B6D**					0.02	28%	0.20	0.26	0.34	0.60
B7 (EX)*					2.20	37%	0.27	0.34	0.41	0.63
B7A		21,047	69,660		2.08	77%	0.64	0.67	0.70	0.79
B7B	26319	12,883			0.90	68%	0.52	0.59	0.63	0.76
B8***					0.18	11%	0.07	0.13	0.21	0.53
C1A#					0.05	41%	0.30	0.37	0.44	0.65
C1B#					0.18	47%	0.35	0.42	0.48	0.67
C1C#					0.31	86%	0.69	0.74	0.77	0.83
C1D#					0.93	89%	0.71	0.76	0.79	0.84
C2#					0.36	92%	0.74	0.79	0.81	0.85
C3***					0.41	88%	0.70	0.76	0.78	0.84
C5#					0.22	50%	0.37	0.45	0.50	0.68
C7 (EX)**					1.75	45%	0.33	0.40	0.47	0.66
C7		26,934	50,346		1.75	67%	0.54	0.58	0.62	0.75
C8**					0.48	80%	0.63	0.69	0.72	0.80
C9		4,162	6,898		0.25	63%	0.48	0.55	0.60	0.74
D1#					0.26	90%	0.72	0.77	0.80	0.84
D2#					0.49	90%	0.72	0.77	0.80	0.84

PROPOSED BASIN FOR AHP EXPANSION (#23079)

FROM RECENTLY CONSTRUCTED MOB III (#18057)
 NOTE: THE TOTAL AREA OF THESE BASINS IS LESS THAN THE 4 BASINS THEY REAPLACED, HENCE THE DIFFERENCE IN TOTAL AREAS ON NEXT PAGE

EX. BASINS PRIOR TO MOB III AND AHP EXPANSION REVISIONS



Composite C Calculations

Project Information
 Project Name: AHP Expansion
 Miro Project No: 23-079
 Revised Date: 5/30/2024
 Calculated By: RJH

Jurisdiction Impervious Value
 Pond Area 100%
 Landscape Area 2%
 Paved Area 100%
 Roof Area 90%

Coefficient Equations
 $C_{CD(2)} = 0.83i + 1.122$
 $C_{CD(5)} = 0.82i + 0.035$
 $C_{CD(10)} = 0.74i + 0.132$
 $C_{CD(100)} = 0.4i + 0.484$

*NOTE: C_{CD} Equations from UDFCD Criteria Manual updated March 2017

Basin Designation	A _{pond} (ft ²)	A _{landscape} (ft ²)	A _{paved} (ft ²)	A _{roof} (ft ²)	A _{total} (acres)	Imperviousness	C _{CD} 02 yr	C _{CD} 05 yr	C _{CD} 10 yr	C _{CD} 100 yr
D3#					0.53	90%	0.72	0.77	0.80	0.84
D4**					0.67	90%	0.72	0.77	0.80	0.84
D5***					0.40	90%	0.72	0.77	0.80	0.84
D6#					0.25	90%	0.72	0.77	0.80	0.84
D7**					0.67	90%	0.72	0.77	0.80	0.84
DA1#					0.66	71%	0.55	0.62	0.66	0.77
DA2#					0.47	95%	0.77	0.81	0.84	0.86
DA5#					0.97	93%	0.75	0.80	0.82	0.86
DA6#					0.61	50%	0.37	0.45	0.50	0.68
DA7#					0.19	96%	0.78	0.82	0.84	0.87
DA8#					0.48	88%	0.70	0.76	0.78	0.84
DA9#					0.08	74%	0.58	0.64	0.68	0.78
DA10#					1.17	99%	0.80	0.85	0.86	0.88
DA11#					0.03	4%	0.02	0.07	0.16	0.50
DA12#					0.43	76%	0.60	0.66	0.69	0.79
DA13*					1.50	69%	0.54	0.60	0.64	0.76
DA15#					0.05	20%	0.13	0.20	0.28	0.56
DA16#					0.08	57%	0.43	0.50	0.55	0.71
OS-1*					6.40	2%	0.01	0.05	0.15	0.49
OS-2*					12.80	2%	0.01	0.05	0.15	0.49
OS-3*					164.50	2%	0.01	0.05	0.15	0.49
OS-4*					3.11	2%	0.01	0.05	0.15	0.49
OS-5*					0.54	100%	0.81	0.86	0.87	0.88
F1*					5.37	63%	0.48	0.55	0.60	0.74
R1#					0.48	90%	0.72	0.77	0.80	0.84
F3*					0.36	69%	0.54	0.60	0.64	0.76
F4*					0.69	73%	0.57	0.63	0.67	0.78
F5#					2.24	100%	0.81	0.86	0.87	0.88
F6*					0.23	71%	0.55	0.62	0.66	0.77
					0.00	-				
South Pond Trib					28.22	46.37%	0.34	0.42	0.48	0.67
SW Pond Trib					26.74	61.08%	0.47	0.54	0.58	0.73
Total Onsite					54.96	53.53%	0.40	0.47	0.53	0.70

EX. BASINS PRIOR TO MOB III AND AHP EXPANSION REVISIONS

From Addendum to Final Drainage Plan dated 7/22/2008

* Approved Master Planned Impervious Values used

** From Update dated 1/6/2010

*** From Update dated 6/13/2014

Text with ~~Strikethrough~~ indicates it has been replaced by new basins. Note F1, DA5, DA6, & DA13 replaced by MOB III (#18057) all other basins have been replaced by AHP Expansion (#23079)

THESE BASINS HAVE BEEN REMOVED FROM THE EX. TOTALS

TOTAL DISTURBED AREAS TRIBUTARY TO PONDS (INCLUDES OFFSITE BASINS)

TOTAL DISTURBED AREAS TRIBUTARY TO PONDS (EXCLUDES OFFSITE BASINS)

South Pond B Tributary Areas & Imperviousness	Unmodified Ex. Total (includes OS-2)	19.31	26%
	Unmodified Ex. Total (excludes OS-2)	6.51	74%
	MOB III Total	8.23	90%
	Proposed Total	0.68	92%
	South Pond B Treatment Total	15.42	83.19%
Southwest Pond A Tributary Areas & Imperviousness	Unmodified Ex. Total (includes OS-1)	20.20	57%
	Unmodified Ex. Total (excludes OS-1)	13.80	82%
	MOB III Total	-	-
	Proposed Total	6.54	75%
	Southwest Pond A Treatment Total	20.34	79.68%



TIME OF CONCENTRATION

Project Information
 Project Name: AHP Expansion
 S.A. Project No: 23-079
 Revised Date: 5/28/2024
 Calculated By: RJH

Conveyance Coefficient Value
 Grassed Waterway 15
 Heavy Meadow 2.5
 Nearly Bare Ground 10
 Paved Areas and Shallow Paved Swales 20
 Short Pasture and Lawns 7
 Tillage / Field 5

Time of Concentration Equations
 $t_i = 0.395(1.1 - C_5)L^{1/2} / S^{1/3}$ $t_t = (L/v)/60$
 $t_c \text{ check: } t_c = (26-17i) + (L/(60(14i+19)S^{1/2}))$

*NOTE: Cv Values, T_i, T_t, & T_c Equations from UDFCD Criteria Manual updated March 2017

SUB-BASIN DATA			INITIAL/OVERLAND TIME (t _i)			TRAVEL TIME (t _t)						t _i + t _t		t _c CHECK (urbanized basins)		FINAL t _c USED
Basin Designation	Area (acres)	C _{CD} 05 yr	length (ft)	slope %	t _i (min)	length (ft)	slope %	Type of Land Surface	Conveyance Coefficient Cv	velocity (ft/sec)	t _t (min)	t _c (min)	Total Length (ft)	t _c (min)	t _c (min)	
G1	0.25	0.60	128	1.09%	10.16	64	2.79%	Paved areas and shallow paved swales	20	3.34	0.32	10.48	192	15.41	10.48	
G2	0.35	0.75	72	2.20%	4.16	238	2.48%	Paved areas and shallow paved swales	20	3.15	1.26	5.42	310	12.67	5.42	
G3	0.50	0.77	160	2.00%	6.02	25	2.00%	Paved areas and shallow paved swales	20	2.83	0.15	6.17	185	11.71	6.17	
G4	0.44	0.46	36	5.55%	3.98	230	2.67%	Paved areas and shallow paved swales	20	3.27	1.17	5.15	265	18.95	5.15	
G5	0.41	0.77	149	2.00%	5.81	61	2.00%	Paved areas and shallow paved swales	20	2.83	0.36	6.17	210	11.85	6.17	
G6	0.15	0.86	57	0.93%	3.47	20.2	2.82%	Paved areas and shallow paved swales	20	3.36	0.10	3.57	77	9.33	5.00	
G7	2.06	0.58	254	3.55%	9.99	525	3.17%	Paved areas and shallow paved swales	20	3.56	2.45	12.45	778	18.73	12.45	
G8	0.38	0.78	225	1.98%	6.96	61	2.9%	Paved areas and shallow paved swales	20	3.38	0.30	7.26	286	11.80	7.26	
G9	0.30	0.81	217	1.55%	6.86	1	1.0%	Paved areas and shallow paved swales	20	2.00	0.01	6.87	218	11.65	6.87	
G10	0.05	0.77	63	2.0%	3.76	1	1.0%	Paved areas and shallow paved swales	20	2.00	0.01	3.77	64	11.19	5.00	
G11	0.23	0.58	51	5.02%	3.95	131	3.7%	Paved areas and shallow paved swales	20	3.84	0.57	4.52	182	15.49	5.00	
G12	2.08	0.68	119	2.78%	6.04	68	5.3%	Paved areas and shallow paved swales	20	4.61	0.25	6.28	187	13.40	6.28	



Runoff Calculations (Rational Method)

Project Information

Project Name: AHP Expansion
 S.A. Project No: 23-079
 Revised Date: 5/28/2024
 Calculated By: RJH

Intensity Equation

$$I = 28.5 (P_1) / (10 + T_c)^{0.786}$$

*NOTE: P & Intensity Equation from UDFCD Criteria Manual

Basin Designation	Area (ac.)	'c'	cA	t _c (min)	P ₁	intensity (in/hr)	Q (cfs)	
G1	0.25	0.54	0.14	10.48	0.99	2.63	0.36	02 YR
		0.60	0.15		1.39	3.69	0.56	05 YR
		0.64	0.16		1.64	4.36	0.71	10 YR
		0.76	0.19		2.60	6.90	1.33	100 YR
G2	0.35	0.71	0.25	5.42	0.99	3.29	0.82	02 YR
		0.75	0.26		1.39	4.61	1.21	05 YR
		0.78	0.27		1.64	5.44	1.48	10 YR
		0.83	0.29		2.60	8.63	2.52	100 YR
G3	0.50	0.74	0.37	6.17	0.99	3.17	1.18	02 YR
		0.77	0.39		1.39	4.45	1.73	05 YR
		0.80	0.40		1.64	5.24	2.11	10 YR
		0.84	0.43		2.60	8.31	3.54	100 YR
G4	0.44	0.39	0.17	5.15	0.99	3.33	0.57	02 YR
		0.46	0.20		1.39	4.68	0.93	05 YR
		0.51	0.22		1.64	5.52	1.23	10 YR
		0.69	0.30		2.60	8.75	2.64	100 YR
G5	0.41	0.74	0.31	6.17	0.99	3.17	0.97	02 YR
		0.77	0.32		1.39	4.44	1.42	05 YR
		0.80	0.33		1.64	5.24	1.73	10 YR
		0.84	0.35		2.60	8.31	2.91	100 YR
G6	0.15	0.83	0.12	5.00	0.99	3.36	0.41	02 YR
		0.86	0.12		1.39	4.71	0.59	05 YR
		0.87	0.13		1.64	5.56	0.71	10 YR
		0.88	0.13		2.60	8.82	1.14	100 YR
G7	2.06	0.52	1.08	12.45	0.99	2.45	2.64	02 YR
		0.58	1.19		1.39	3.43	4.10	05 YR
		0.62	1.28		1.64	4.05	5.20	10 YR
		0.75	1.55		2.60	6.42	9.93	100 YR
G8	0.38	0.75	0.28	7.26	0.99	3.01	0.86	02 YR
		0.78	0.30		1.39	4.22	1.26	05 YR
		0.81	0.31		1.64	4.98	1.53	10 YR
		0.85	0.32		2.60	7.90	2.55	100 YR
G9	0.30	0.77	0.23	6.87	0.99	3.06	0.72	02 YR
		0.81	0.24		1.39	4.30	1.05	05 YR
		0.83	0.25		1.64	5.07	1.27	10 YR
		0.86	0.26		2.60	8.04	2.10	100 YR
G10	0.05	0.74	0.04	5.00	0.99	3.36	0.12	02 YR
		0.77	0.04		1.39	4.71	0.18	05 YR
		0.80	0.04		1.64	5.56	0.21	10 YR
		0.84	0.04		2.60	8.82	0.36	100 YR
G11	0.23	0.53	0.12	5.00	0.99	3.36	0.42	02 YR
		0.58	0.14		1.39	4.71	0.65	05 YR
		0.63	0.15		1.64	5.56	0.82	10 YR
		0.75	0.18		2.60	8.82	1.56	100 YR



Runoff Calculations (Rational Method)

Project Information

Project Name: AHP Expansion
 S.A. Project No: 23-079
 Revised Date: 5/28/2024
 Calculated By: RJH

Intensity Equation

$$I = 28.5 (P_1) / (10 + T_c)^{0.786}$$

*NOTE: P & Intensity Equation from UDFCD Criteria Manual

Basin Designation	Area (ac.)	'c'	cA	t _c (min)	P ₁	intensity (in/hr)	Q (cfs)	
G12	2.08	0.63	1.31	6.28	0.99	3.15	4.12	02 YR
		0.68	1.41		1.39	4.42	6.22	05 YR
		0.71	1.48		1.64	5.21	7.71	10 YR
		0.80	1.66		2.60	8.27	13.71	100 YR

RUNOFF SUMMARY						
Design Point	Tributary Basin(s)	Tributary Area (ac.)	Direct Runoff (CFS/5-yr)	Total Runoff (CFS/5-yr)	Direct Runoff (CFS/100-yr)	Total Runoff (CFS/100-yr)
-	G1	0.25	0.56	-	1.33	-
-	EX. DP X3	-	-	9.12	-	19.95
1	G1, EX. DP X3	-	-	9.68	-	21.28
-	D5	0.40	1.25	-	2.65	-
2	D5, DP1	-	-	10.93	-	23.93
-	G2	0.35	1.21	-	2.52	-
3	G2, DP2	-	-	12.14	-	26.45
-	G3	0.50	1.73	-	3.54	-
4	G3, DP3	-	-	13.88	-	29.99
-	G4	0.44	0.93	-	2.64	-
5	G4, DP4	-	-	14.81	-	32.62
-	G5	0.41	1.42	-	2.91	-
-	D4	-	2.37	-	4.95	-
-	G6	0.15	0.59	-	1.14	-
6	G5, D4, DP5	-	-	4.38	-	8.99
-	G7	2.06	4.10	-	9.93	-
-	G11	0.23	0.65	-	1.56	-
7	G7, G11, DP5, DP6	-	-	23.93	-	53.10
-	G8	0.38	1.26	-	2.55	-
-	G9	0.30	1.05	-	2.10	-
8	G8, G9	0.68	-	2.31	-	4.65
-	EX. DP 8	3.74	-	6.68	-	17.80
9	DP8, EX. DP 8	4.42	-	8.99	-	22.45
-	G10	0.05	0.18	-	0.36	-
-	G12	2.08	6.63	-	14.62	-

TOTAL INTO
SOUTHWEST
POND A

TOTAL INTO
SOUTH POND B

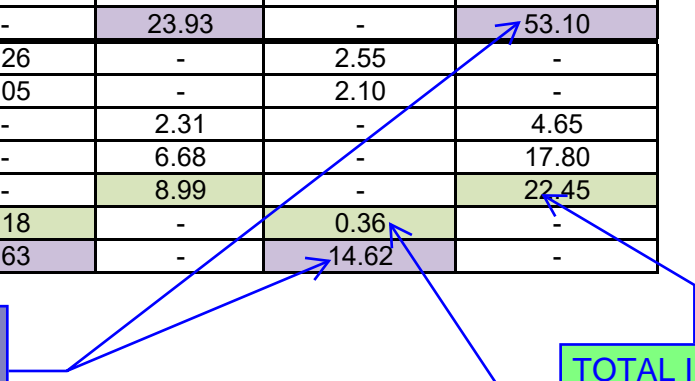

COLOR CODING LEGEND

COLOR CODING LEGEND

OUTFALLS INTO SOUTH POND B

OUTFALLS INTO SOUTHWEST POND A

EXISTING RUNOFF SUMMARY (FROM PREVIOUS DRAINAGE REPORTS/LETTERS) NOTE: EXCLUDES UNDISTURBED AREAS, INCLUDED FOR RUNOFF COMPARISSON FOR AHP EXPANSION			
Ex. Tributary Basin(s)	Prop. Tributary Basin(s)	Ex. Total Runoff (CFS/5-yr)	Ex. Total Runoff (CFS/100-yr)
DA7	G9	0.74	1.45
DA9	G7	0.16	0.30
DA10	G4, G8	3.15	5.63
DA12	G2	1.19	2.71
B7A	G12	-	10.73
C3	G1	1.25	2.65
C5	G3	0.41	1.17
C7	G7	2.61	8.09
C8	G5, G6	1.63	3.54
C9	G11	0.63	2.04
F6	G7	0.55	1.31
EX. DP X3	N/A	9.12	19.95
D5	N/A	1.25	2.65
D4	N/A	2.37	4.95
EX. DP 8	N/A	6.68	17.80
	Proposed Runoff (CFS/100-yr)	Ex. Total Runoff (CFS/5-yr)	Ex. Total Runoff (CFS/100-yr)
Total South Pond B	22.81	11.92	27.89
Total Southwest Pond A	66.81	-	57.08

FROM MOB III RUNOFF CALCS (MIRO #18057)

FROM PARKING EXPANSION ROUTING CALCS (MIRO #18057)

FROM PARKING STRUTURE ROUTING CALCS (MIRO #14004)

FROM MAIN HOSPITAL CALCS (MIRO #07135)

AdventHealth Parker Expansion

Appendix C Hydraulic Calculations

DETENTION BASIN STAGE-STORAGE TABLE BUILDER

MHFD-Detention, Version 4.06 (July 2022)

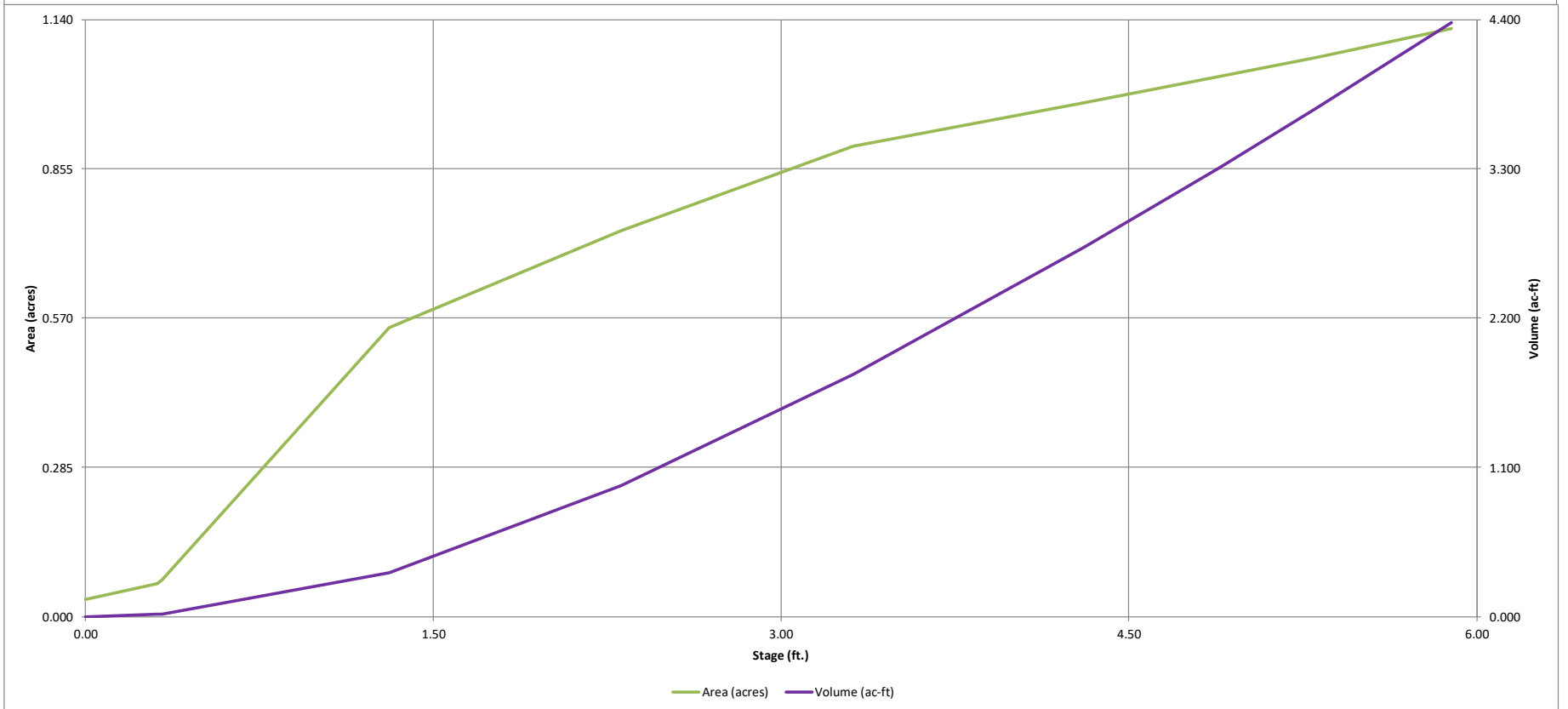
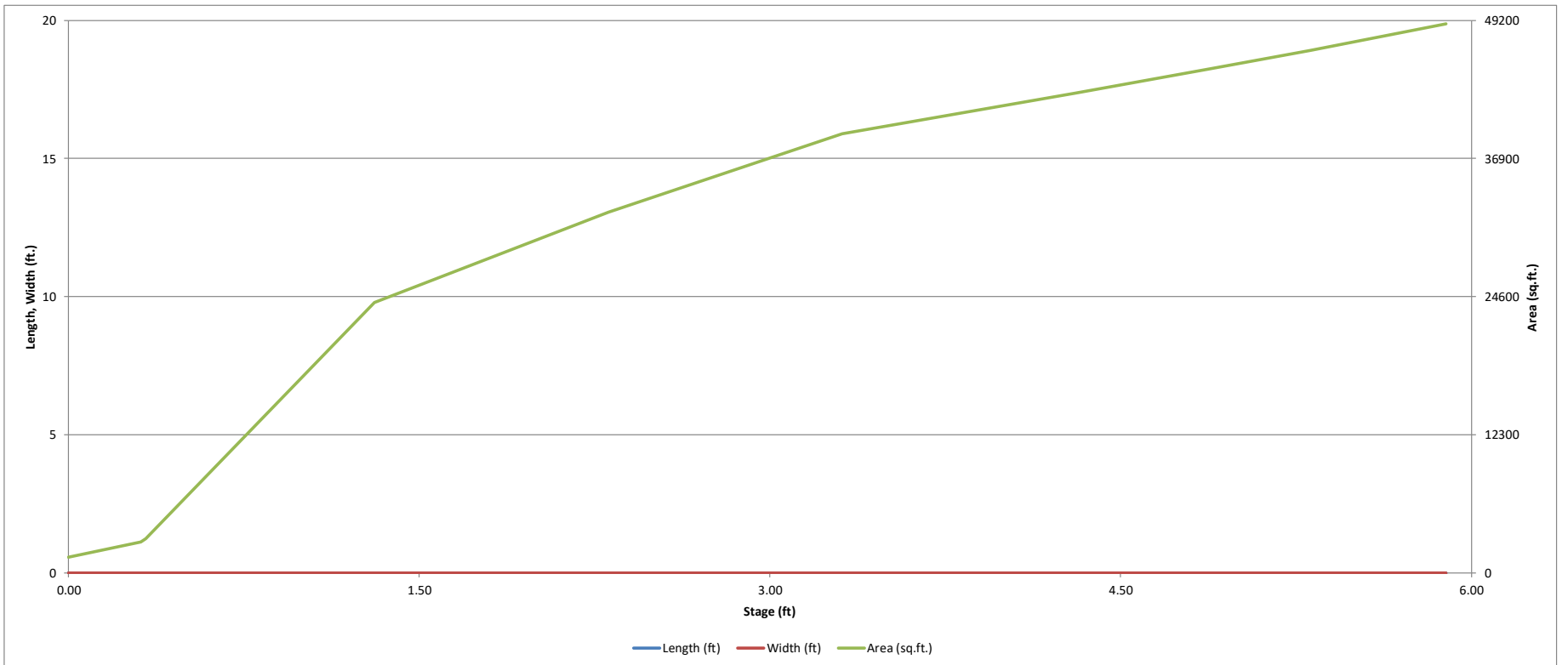

DETENTION BASIN OUTLET STRUCTURE DESIGN

MHFD-Detention, Version 4.06 (July 2022)

Project: AdventHealth Parker - Southwest Pond A (Miro Job # 23079)

Basin ID: Proposed Tributary Basins (Excludes Offsite Basin OS-1)

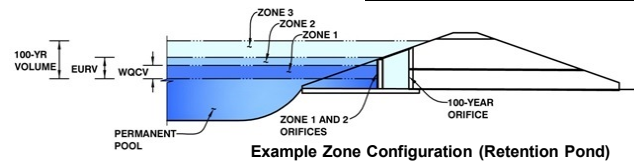

	Estimated Stage (ft)	Estimated Volume (ac-ft)	Outlet Type
Zone 1 (WQCV)	1.71	0.553	Orifice Plate
Zone 2 (EURV)	3.28	1.194	Orifice Plate
Zone 3 (100-year)	4.40	1.061	Weir&Pipe (Restrict)
Total (all zones)		2.808	

User Input: Orifice at Underdrain Outlet (typically used to drain WQCV in a Filtration BMP)

Underdrain Orifice Invert Depth = ft (distance below the filtration media surface)
 Underdrain Orifice Diameter = inches

Calculated Parameters for Underdrain

Underdrain Orifice Area = ft²
 Underdrain Orifice Centroid = feet

User Input: Orifice Plate with one or more orifices or Elliptical Slot Weir (typically used to drain WQCV and/or EURV in a sedimentation BMP)

Centroid of Lowest Orifice = ft (relative to basin bottom at Stage = 0 ft)
 Depth at top of Zone using Orifice Plate = ft (relative to basin bottom at Stage = 0 ft)
 Orifice Plate: Orifice Vertical Spacing = inches
 Orifice Plate: Orifice Area per Row = sq. inches (use rectangular openings)

Calculated Parameters for Plate

WQ Orifice Area per Row = ft²
 Elliptical Half-Width = feet
 Elliptical Slot Centroid = feet
 Elliptical Slot Area = ft²

User Input: Stage and Total Area of Each Orifice Row (numbered from lowest to highest)

	Row 1 (required)	Row 2 (optional)	Row 3 (optional)	Row 4 (optional)	Row 5 (optional)	Row 6 (optional)	Row 7 (optional)	Row 8 (optional)
Stage of Orifice Centroid (ft)	0.00	1.00	2.00	3.00				
Orifice Area (sq. inches)	3.75	3.75	3.75	3.75				

	Row 9 (optional)	Row 10 (optional)	Row 11 (optional)	Row 12 (optional)	Row 13 (optional)	Row 14 (optional)	Row 15 (optional)	Row 16 (optional)
Stage of Orifice Centroid (ft)								
Orifice Area (sq. inches)								

User Input: Vertical Orifice (Circular or Rectangular)

	Not Selected	Not Selected	
Invert of Vertical Orifice =	N/A	N/A	ft (relative to basin bottom at Stage = 0 ft)
Depth at top of Zone using Vertical Orifice =	N/A	N/A	ft (relative to basin bottom at Stage = 0 ft)
Vertical Orifice Diameter =	N/A	N/A	inches

Calculated Parameters for Vertical Orifice

	Not Selected	Not Selected	
Vertical Orifice Area =	N/A	N/A	ft ²
Vertical Orifice Centroid =	N/A	N/A	feet

User Input: Overflow Weir (Dropbox with Flat or Sloped Grate and Outlet Pipe OR Rectangular/Trapezoidal Weir and No Outlet Pipe)

	Zone 3 Weir	Not Selected	
Overflow Weir Front Edge Height, Ho =	5.10	N/A	ft (relative to basin bottom at Stage = 0 ft)
Overflow Weir Front Edge Length =	12.00	N/A	feet
Overflow Weir Grate Slope =	4.00	N/A	H:V
Horiz. Length of Weir Sides =	2.00	N/A	feet
Overflow Grate Type =	Type C Grate	N/A	
Debris Clogging % =	0%	N/A	%

Calculated Parameters for Overflow Weir

	Zone 3 Weir	Not Selected	
Height of Grate Upper Edge, H _g =	5.60	N/A	feet
Overflow Weir Slope Length =	2.06	N/A	feet
Grate Open Area / 100-yr Orifice Area =	5.71	N/A	
Overflow Grate Open Area w/o Debris =	17.22	N/A	ft ²
Overflow Grate Open Area w/ Debris =	17.22	N/A	ft ²

User Input: Outlet Pipe w/ Flow Restriction Plate (Circular Orifice, Restrictor Plate, or Rectangular Orifice)

	Zone 3 Restrictor	Not Selected	
Depth to Invert of Outlet Pipe =	0.00	N/A	ft (distance below basin bottom at Stage = 0 ft)
Outlet Pipe Diameter =	24.00	N/A	inches
Restrictor Plate Height Above Pipe Invert =	22.00		inches

Calculated Parameters for Outlet Pipe w/ Flow Restriction Plate

	Zone 3 Restrictor	Not Selected	
Outlet Orifice Area =	3.02	N/A	ft ²
Outlet Orifice Centroid =	0.96	N/A	feet
Half-Central Angle of Restrictor Plate on Pipe =	2.56	N/A	radians

User Input: Emergency Spillway (Rectangular or Trapezoidal)

Spillway Invert Stage = ft (relative to basin bottom at Stage = 0 ft)
 Spillway Crest Length = feet
 Spillway End Slopes = H:V
 Freeboard above Max Water Surface = feet

Calculated Parameters for Spillway

Spillway Design Flow Depth = feet
 Stage at Top of Freeboard = feet
 Basin Area at Top of Freeboard = acres
 Basin Volume at Top of Freeboard = acre-ft

Routed Hydrograph Results

The user can override the default CUHP hydrographs and runoff volumes by entering new values in the Inflow Hydrographs table (Columns W through AF).

	WQCV	EURV	2 Year	5 Year	10 Year	25 Year	50 Year	100 Year	500 Year
Design Storm Return Period =									
One-Hour Rainfall Depth (in) =	N/A	N/A	0.99	1.39	1.64	1.98	2.31	2.60	3.08
CUHP Runoff Volume (acre-ft) =	0.553	1.747	1.251	1.880	2.289	2.914	3.485	4.019	4.864
Inflow Hydrograph Volume (acre-ft) =	N/A	N/A	1.251	1.880	2.289	2.914	3.485	4.019	4.864
CUHP Predevelopment Peak Q (cfs) =	N/A	N/A	0.3	4.4	7.7	17.0	23.2	29.3	38.1
OPTIONAL Override Predevelopment Peak Q (cfs) =	N/A	N/A							
Predevelopment Unit Peak Flow, q (cfs/acre) =	N/A	N/A	0.01	0.22	0.38	0.84	1.14	1.44	1.87
Peak Inflow Q (cfs) =	N/A	N/A	24.1	35.9	42.4	55.2	66.3	77.4	93.1
Peak Outflow Q (cfs) =	0.3	0.6	0.5	0.6	0.7	0.8	0.9	3.4	10.7
Ratio Peak Outflow to Predevelopment Q =	N/A	N/A	N/A	0.1	0.1	0.0	0.0	0.1	0.3
Structure Controlling Flow =	Plate	Plate	Plate	Plate	Plate	Plate	Plate	Overflow Weir 1	Overflow Weir 1
Max Velocity through Grate 1 (fps) =	N/A	N/A	N/A	N/A	N/A	N/A	N/A	N/A	0.6
Max Velocity through Grate 2 (fps) =	N/A	N/A	N/A	N/A	N/A	N/A	N/A	N/A	N/A
Time to Drain 97% of Inflow Volume (hours) =	39	69	60	72	77	85	90	93	91
Time to Drain 99% of Inflow Volume (hours) =	42	74	64	77	83	92	99	102	101
Maximum Ponding Depth (ft) =	1.71	3.28	2.60	3.32	3.75	4.38	4.93	5.33	5.65
Area at Maximum Ponding Depth (acres) =	0.63	0.89	0.78	0.90	0.93	0.99	1.03	1.07	1.10
Maximum Volume Stored (acre-ft) =	0.556	1.756	1.178	1.783	2.176	2.791	3.347	3.767	4.114

DETENTION BASIN OUTLET STRUCTURE DESIGN

MHFD-Detention, Version 4.06 (July 2022)

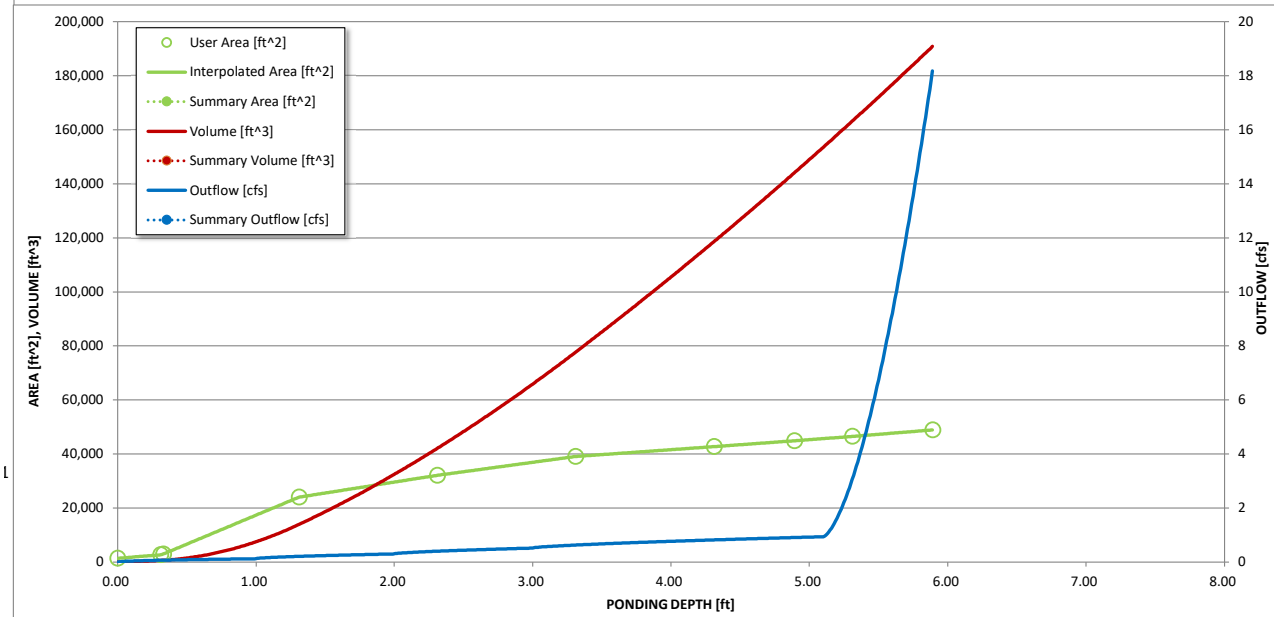
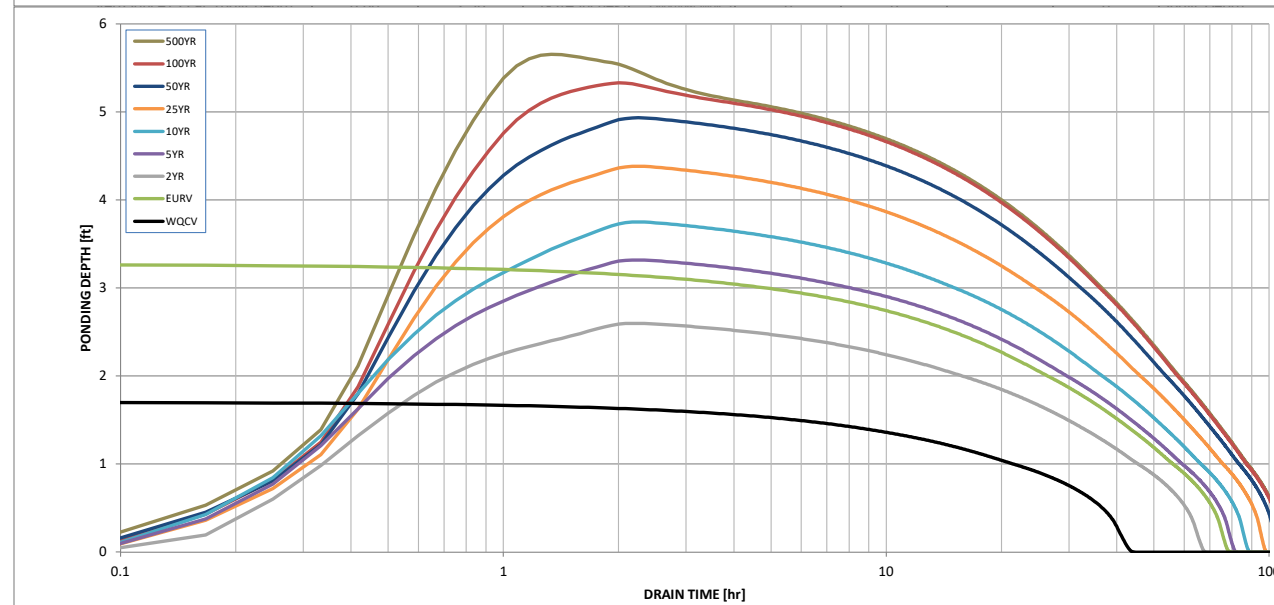
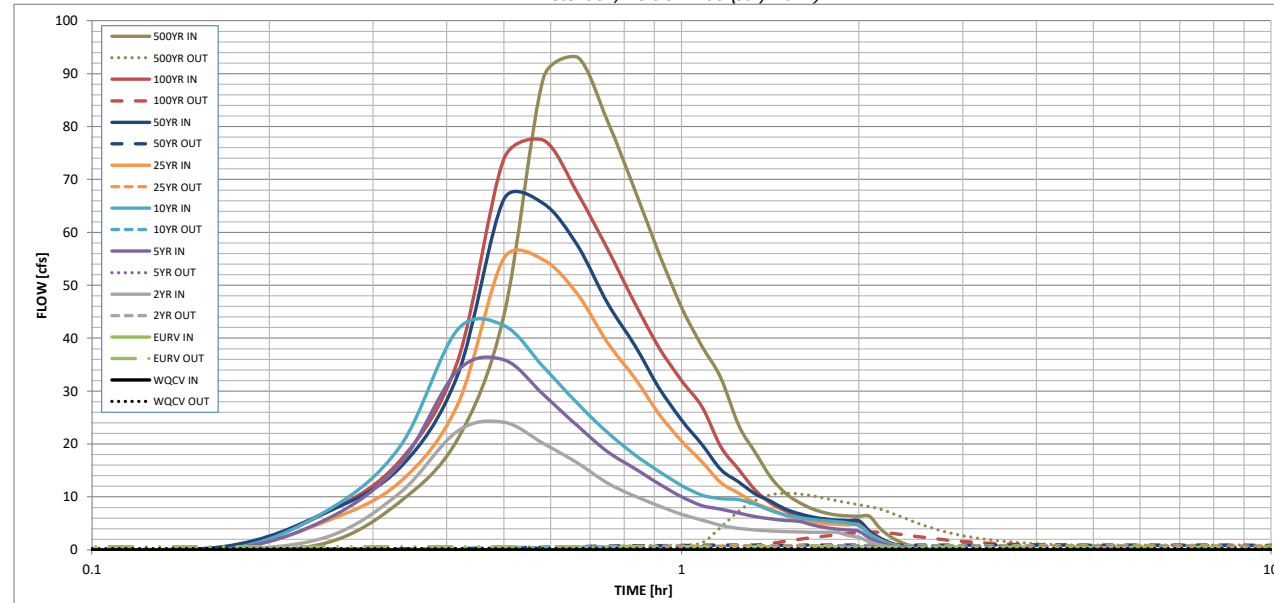

S-A-V-D Chart Axis Override	X-axis	Left Y-Axis	Right Y-Axis
minimum bound			
maximum bound			

DETENTION BASIN STAGE-STORAGE TABLE BUILDER

MHFD-Detention, Version 4.06 (July 2022)

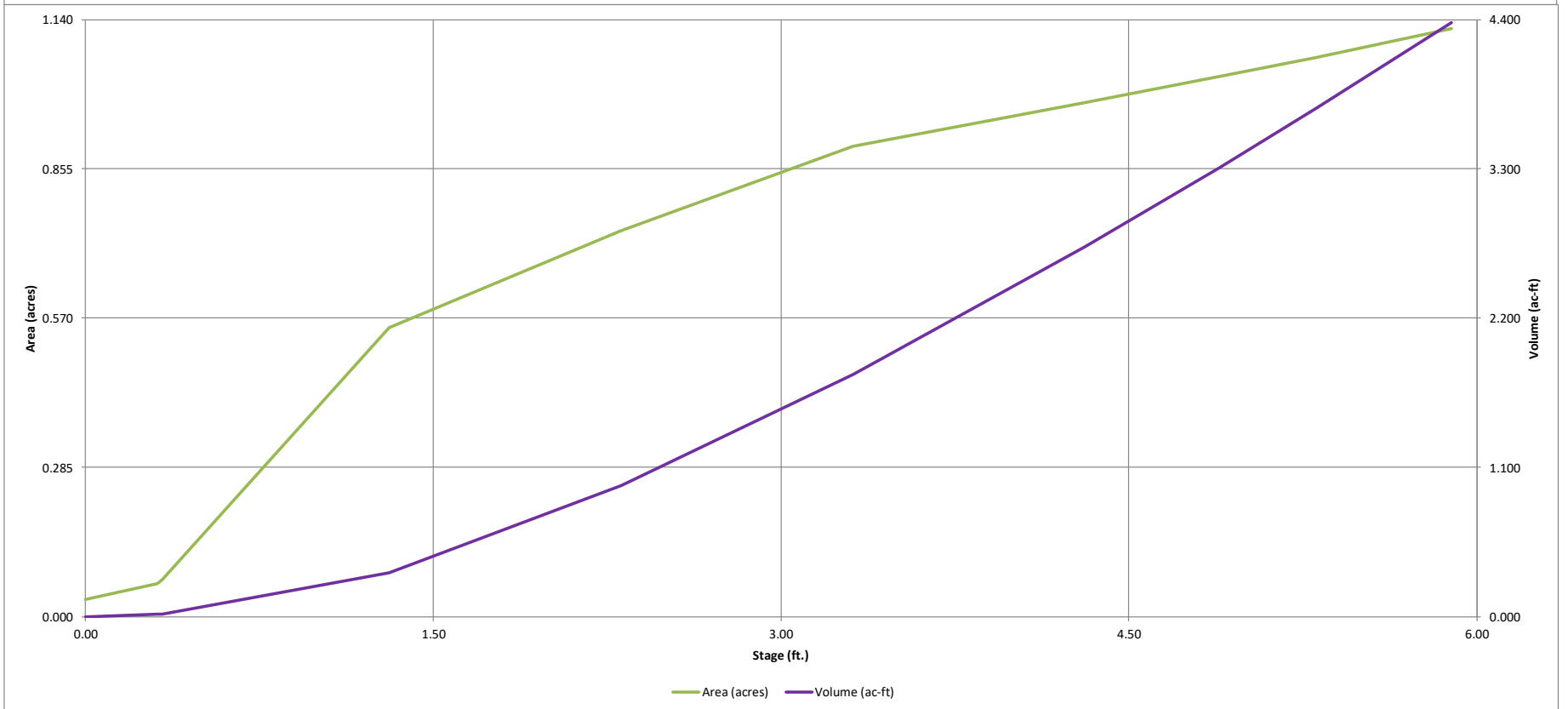
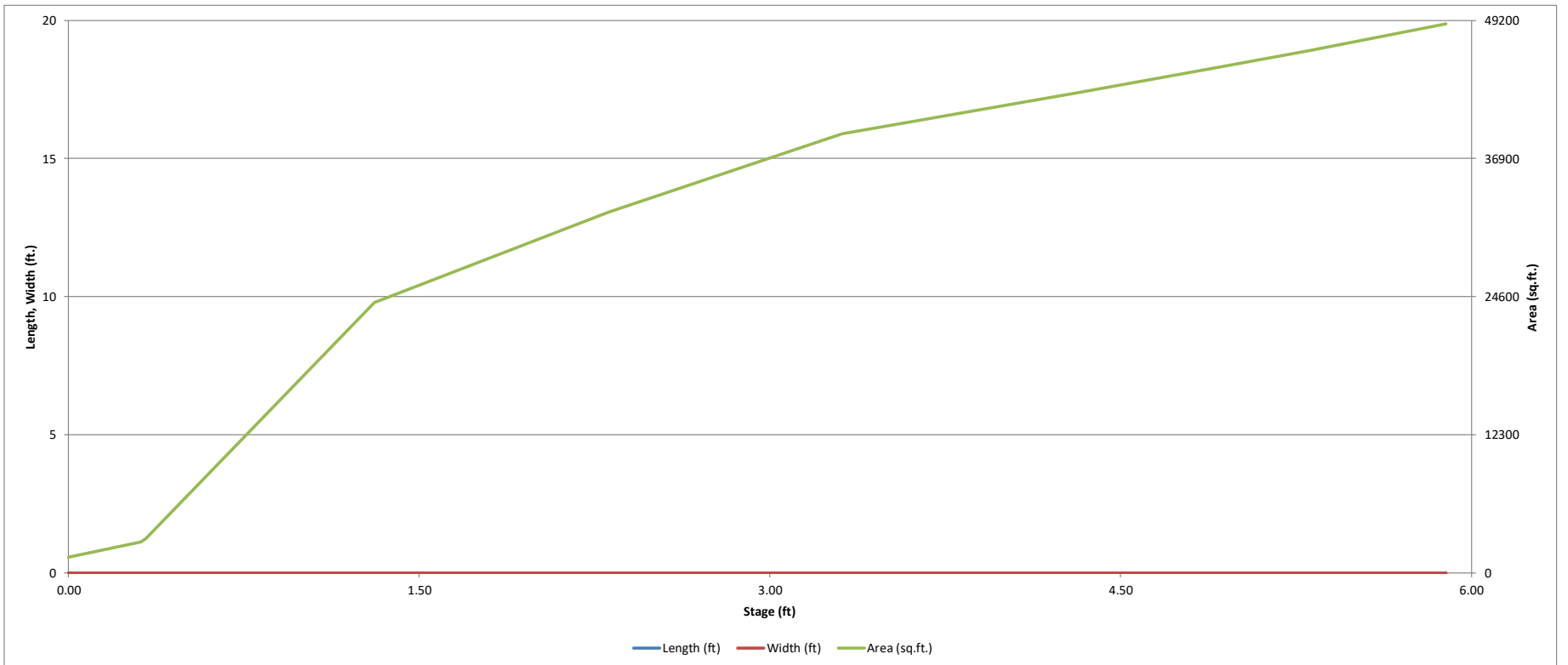

DETENTION BASIN OUTLET STRUCTURE DESIGN

MHFD-*Detention*, Version 4.06 (July 2022)

Project: **AdventHealth Parker - Southwest Pond A (Miro Job # 23079)**

Basin ID: **Proposed Tributary Basins (Excludes Offsite Basin OS-1)**

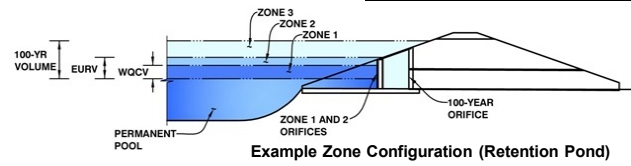

	Estimated Stage (ft)	Estimated Volume (ac-ft)	Outlet Type
Zone 1 (WQCV)	1.68	0.534	Orifice Plate
Zone 2 (EURV)	3.22	1.160	Orifice Plate
Zone 3 (100-year)	4.54	1.250	Weir&Pipe (Restrict)
Total (all zones)		2.945	

User Input: Orifice at Underdrain Outlet (typically used to drain WQCV in a Filtration BMP)

Underdrain Orifice Invert Depth = ft (distance below the filtration media surface)
 Underdrain Orifice Diameter = inches

Calculated Parameters for Underdrain

Underdrain Orifice Area = ft²
 Underdrain Orifice Centroid = feet

User Input: Orifice Plate with one or more orifices or Elliptical Slot Weir (typically used to drain WQCV and/or EURV in a sedimentation BMP)

Centroid of Lowest Orifice = ft (relative to basin bottom at Stage = 0 ft)
 Depth at top of Zone using Orifice Plate = ft (relative to basin bottom at Stage = 0 ft)
 Orifice Plate: Orifice Vertical Spacing = inches
 Orifice Plate: Orifice Area per Row = sq. inches (use rectangular openings)

Calculated Parameters for Plate

WQ Orifice Area per Row = ft²
 Elliptical Half-Width = feet
 Elliptical Slot Centroid = feet
 Elliptical Slot Area = ft²

User Input: Stage and Total Area of Each Orifice Row (numbered from lowest to highest)

	Row 1 (required)	Row 2 (optional)	Row 3 (optional)	Row 4 (optional)	Row 5 (optional)	Row 6 (optional)	Row 7 (optional)	Row 8 (optional)
Stage of Orifice Centroid (ft)	0.00	1.00	2.00	3.00				
Orifice Area (sq. inches)	3.75	3.75	3.75	3.75				

	Row 9 (optional)	Row 10 (optional)	Row 11 (optional)	Row 12 (optional)	Row 13 (optional)	Row 14 (optional)	Row 15 (optional)	Row 16 (optional)
Stage of Orifice Centroid (ft)								
Orifice Area (sq. inches)								

User Input: Vertical Orifice (Circular or Rectangular)

Invert of Vertical Orifice = Not Selected Not Selected ft (relative to basin bottom at Stage = 0 ft)
 Depth at top of Zone using Vertical Orifice = Not Selected Not Selected ft (relative to basin bottom at Stage = 0 ft)
 Vertical Orifice Diameter = Not Selected Not Selected inches

Calculated Parameters for Vertical Orifice

Vertical Orifice Area = Not Selected Not Selected ft²
 Vertical Orifice Centroid = Not Selected Not Selected feet

User Input: Overflow Weir (Dropbox with Flat or Sloped Grate and Outlet Pipe OR Rectangular/Trapezoidal Weir and No Outlet Pipe)

Overflow Weir Front Edge Height, H_o = Zone 3 Weir Not Selected ft (relative to basin bottom at Stage = 0 ft)
 Overflow Weir Front Edge Length = Zone 3 Weir Not Selected feet
 Overflow Weir Grate Slope = Zone 3 Weir Not Selected H:V
 Horiz. Length of Weir Sides = Zone 3 Weir Not Selected feet
 Overflow Grate Type = Zone 3 Weir Not Selected
 Debris Clogging % = Zone 3 Weir Not Selected %

Calculated Parameters for Overflow Weir

Height of Grate Upper Edge, H_g = Zone 3 Weir Not Selected feet
 Overflow Weir Slope Length = Zone 3 Weir Not Selected feet
 Grate Open Area / 100-yr Orifice Area = Zone 3 Weir Not Selected
 Overflow Grate Open Area w/o Debris = Zone 3 Weir Not Selected ft²
 Overflow Grate Open Area w/ Debris = Zone 3 Weir Not Selected ft²

User Input: Outlet Pipe w/ Flow Restriction Plate (Circular Orifice, Restrictor Plate, or Rectangular Orifice)

Depth to Invert of Outlet Pipe = Zone 3 Restrictor Not Selected ft (distance below basin bottom at Stage = 0 ft)
 Outlet Pipe Diameter = Zone 3 Restrictor Not Selected inches
 Restrictor Plate Height Above Pipe Invert = Zone 3 Restrictor Not Selected inches

Calculated Parameters for Outlet Pipe w/ Flow Restriction Plate

Outlet Orifice Area = Zone 3 Restrictor Not Selected ft²
 Outlet Orifice Centroid = Zone 3 Restrictor Not Selected feet
 Half-Central Angle of Restrictor Plate on Pipe = Zone 3 Restrictor Not Selected radians

User Input: Emergency Spillway (Rectangular or Trapezoidal)

Spillway Invert Stage = 5.89 ft (relative to basin bottom at Stage = 0 ft)
 Spillway Crest Length = 19.00 feet
 Spillway End Slopes = 33.00 H:V
 Freeboard above Max Water Surface = 1.00 feet

Calculated Parameters for Spillway

Spillway Design Flow Depth = 0.75 feet
 Stage at Top of Freeboard = 7.64 feet
 Basin Area at Top of Freeboard = 1.12 acres
 Basin Volume at Top of Freeboard = 4.38 acre-ft

Routed Hydrograph Results

The user can override the default CUHP hydrographs and runoff volumes by entering new values in the Inflow Hydrographs table (Columns W through AF).

	WQCV	EURV	2 Year	5 Year	10 Year	25 Year	50 Year	100 Year	500 Year
Design Storm Return Period	N/A	N/A	0.99	1.39	1.64	1.98	2.31	2.60	3.08
One-Hour Rainfall Depth (in)	N/A	N/A	0.99	1.39	1.64	1.98	2.31	2.60	3.08
CUHP Runoff Volume (acre-ft)	0.534	1.695	1.234	1.943	2.432	3.276	3.999	4.726	5.807
Inflow Hydrograph Volume (acre-ft)	N/A	N/A	1.234	1.943	2.432	3.276	3.999	4.726	5.807
CUHP Predevelopment Peak Q (cfs)	N/A	N/A	0.4	6.4	11.3	24.8	33.7	42.5	55.2
OPTIONAL Override Predevelopment Peak Q (cfs)	N/A	N/A							
Predevelopment Unit Peak Flow, q (cfs/acre)	N/A	N/A	0.02	0.24	0.42	0.93	1.26	1.59	2.06
Peak Inflow Q (cfs)	N/A	N/A	23.7	38.5	47.2	64.3	78.5	94.2	114.8
Peak Outflow Q (cfs)	0.3	0.6	0.5	0.6	0.8	0.9	3.3	9.8	18.2
Ratio Peak Outflow to Predevelopment Q	N/A	N/A	N/A	0.1	0.1	0.0	0.1	0.2	0.3
Structure Controlling Flow	Plate	Plate	Plate	Plate	Plate	Plate	Overflow Weir 1	Overflow Weir 1	N/A
Max Velocity through Grate 1 (fps)	N/A	N/A	N/A	N/A	N/A	N/A	N/A	0.1	0.5
Max Velocity through Grate 2 (fps)	N/A	N/A	N/A	N/A	N/A	N/A	N/A	N/A	N/A
Time to Drain 97% of Inflow Volume (hours)	39	68	60	73	79	88	93	91	88
Time to Drain 99% of Inflow Volume (hours)	41	73	64	78	85	96	102	101	100
Maximum Ponding Depth (ft)	1.68	3.22	2.58	3.39	3.90	4.73	5.32	5.62	5.89
Area at Maximum Ponding Depth (acres)	0.62	0.88	0.78	0.90	0.95	1.02	1.07	1.10	1.12
Maximum Volume Stored (acre-ft)	0.537	1.702	1.162	1.846	2.317	3.141	3.757	4.081	4.381

DETENTION BASIN OUTLET STRUCTURE DESIGN

MHFD-Detention, Version 4.06 (July 2022)

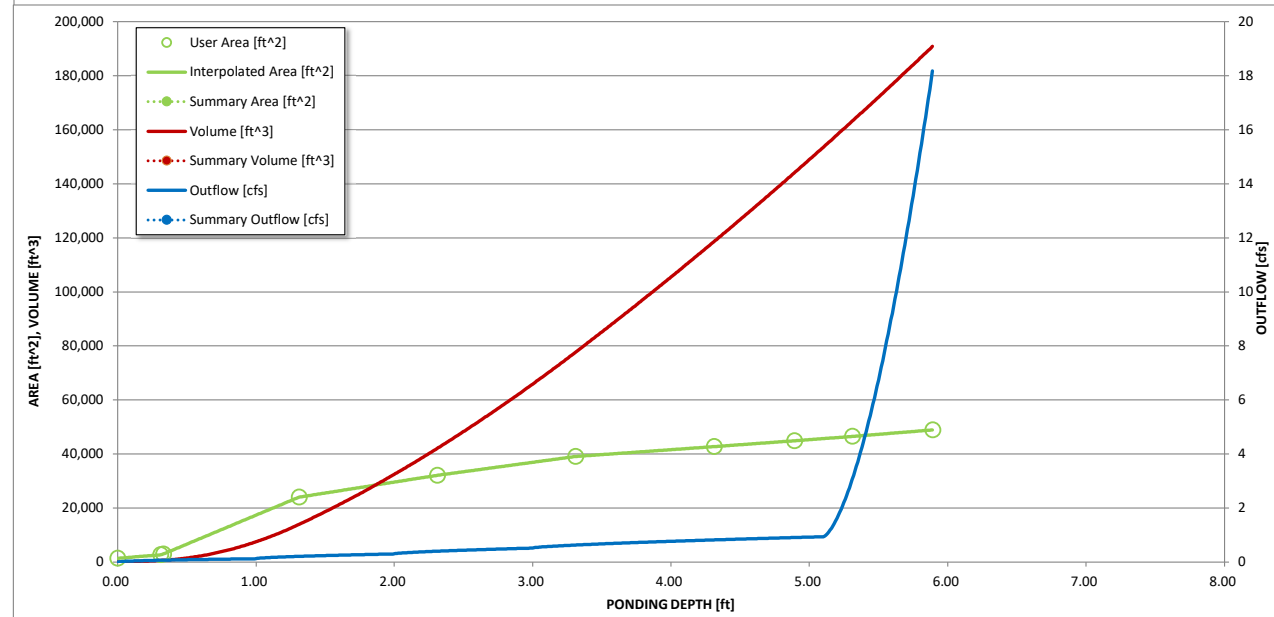
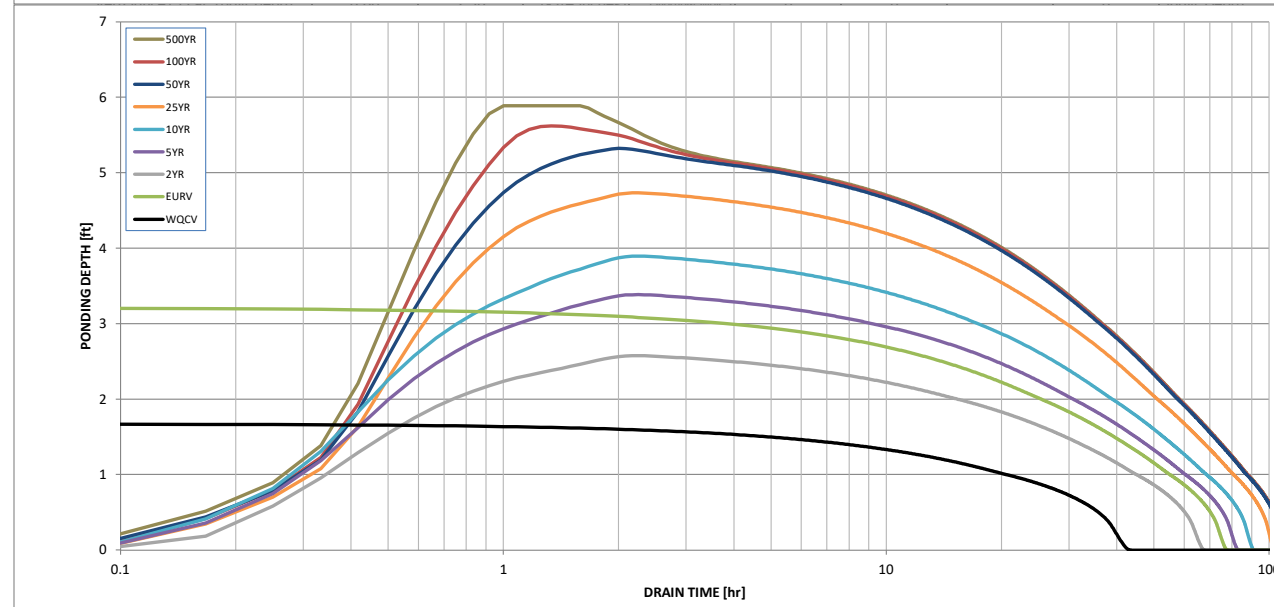
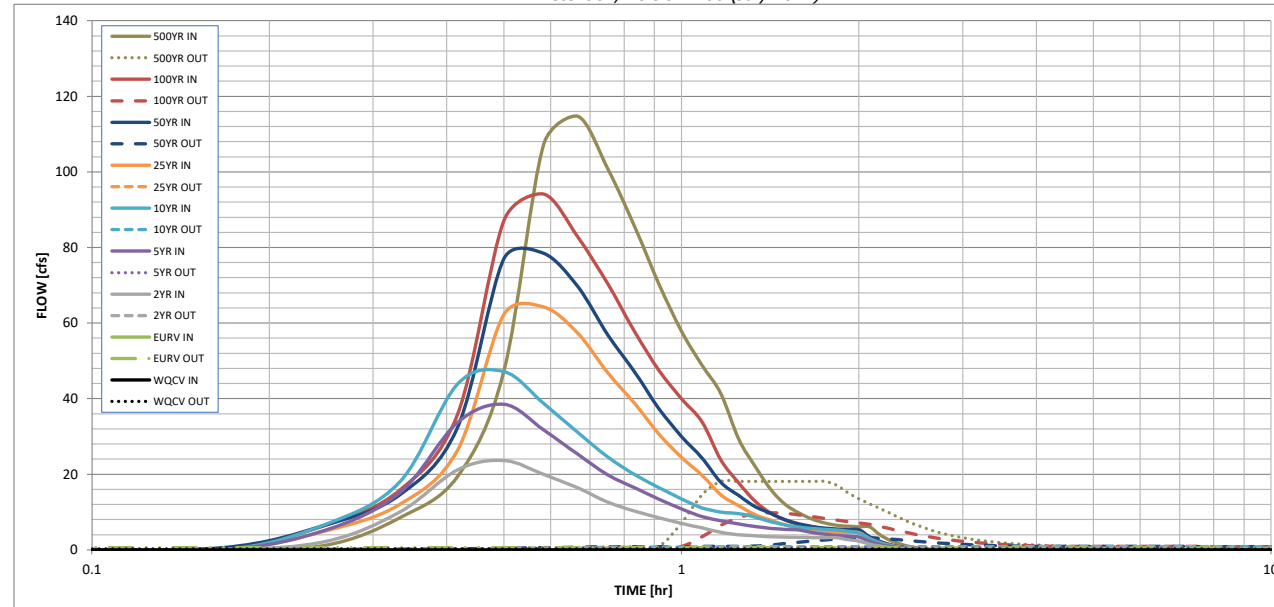

S-A-V-D Chart Axis Override	X-axis	Left Y-Axis	Right Y-Axis
minimum bound			
maximum bound			

DETENTION BASIN STAGE-STORAGE TABLE BUILDER

MHFD-Detention, Version 4.06 (July 2022)

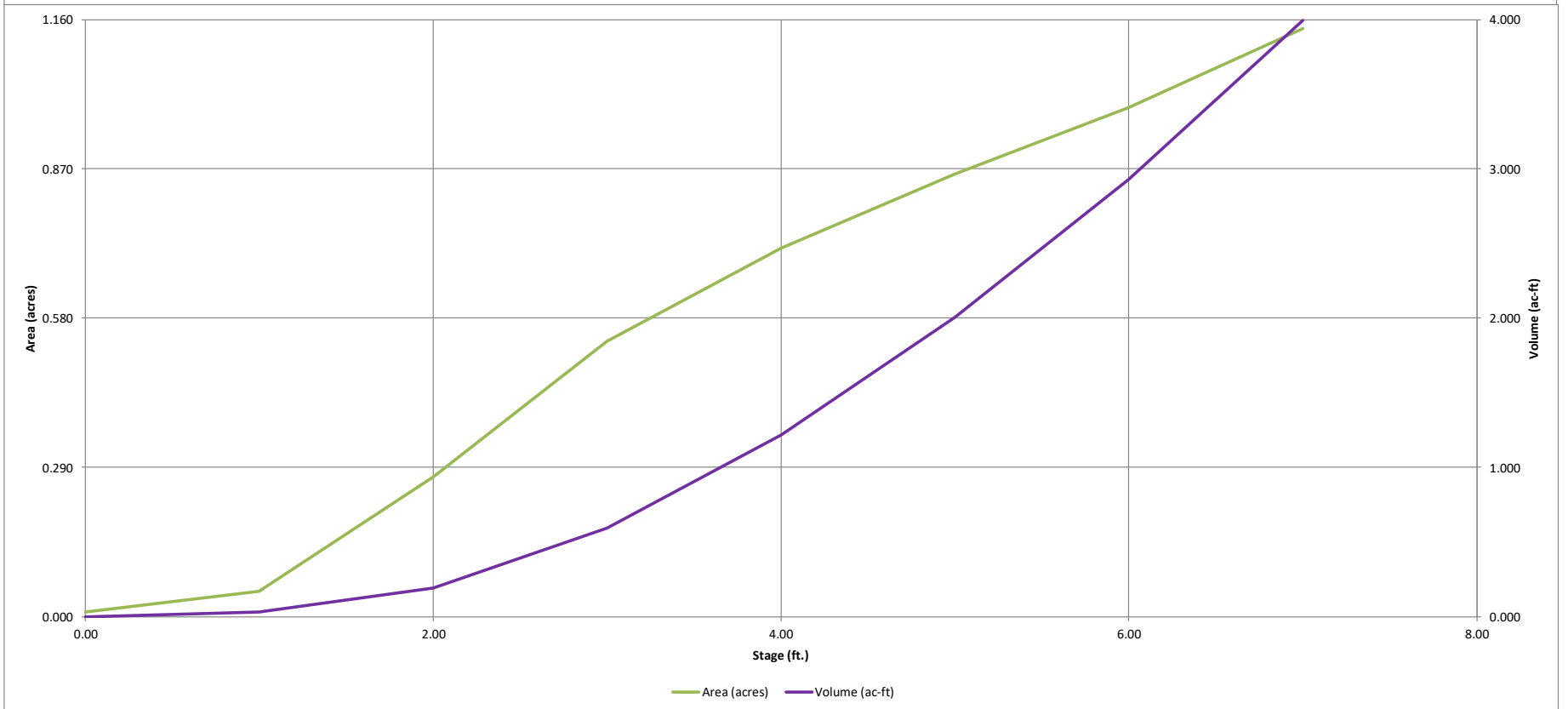
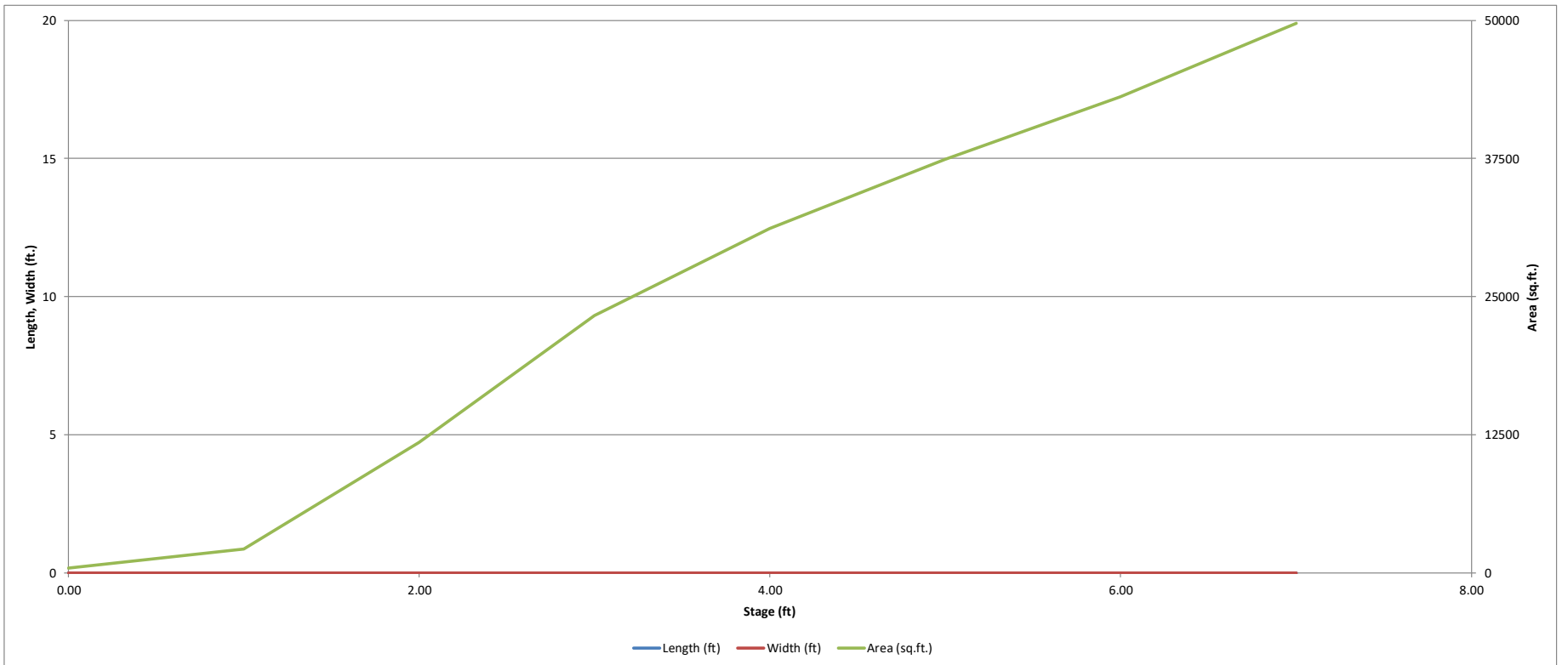

DETENTION BASIN OUTLET STRUCTURE DESIGN

MHFD-Detention, Version 4.06 (July 2022)

Project: AdventHealth Parker - South Pond B (Miro Job # 23079)

Basin ID: Proposed Tributary Basins (Excludes Offsite Basins)

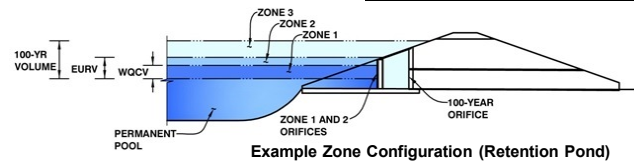

Example Zone Configuration (Retention Pond)

	Estimated Stage (ft)	Estimated Volume (ac-ft)	Outlet Type
Zone 1 (WQCV)	2.72	0.449	Orifice Plate
Zone 2 (EURV)	4.07	0.815	Weir&Pipe (Circular)
Zone 3 (100-year)	5.12	0.837	Weir&Pipe (Restrict)
Total (all zones)		2.101	

User Input: Orifice at Underdrain Outlet (typically used to drain WQCV in a Filtration BMP)

Underdrain Orifice Invert Depth =	N/A	ft (distance below the filtration media surface)
Underdrain Orifice Diameter =	N/A	inches

Calculated Parameters for Underdrain

Underdrain Orifice Area =	N/A	ft ²
Underdrain Orifice Centroid =	N/A	feet

User Input: Orifice Plate with one or more orifices or Elliptical Slot Weir (typically used to drain WQCV and/or EURV in a sedimentation BMP)

Centroid of Lowest Orifice =	0.00	ft (relative to basin bottom at Stage = 0 ft)
Depth at top of Zone using Orifice Plate =	2.72	ft (relative to basin bottom at Stage = 0 ft)
Orifice Plate: Orifice Vertical Spacing =	12.00	inches
Orifice Plate: Orifice Area per Row =	1.60	sq. inches (diameter = 1-7/16 inches)

Calculated Parameters for Plate

WQ Orifice Area per Row =	1.111E-02	ft ²
Elliptical Half-Width =	N/A	feet
Elliptical Slot Centroid =	N/A	feet
Elliptical Slot Area =	N/A	ft ²

User Input: Stage and Total Area of Each Orifice Row (numbered from lowest to highest)

	Row 1 (required)	Row 2 (optional)	Row 3 (optional)	Row 4 (optional)	Row 5 (optional)	Row 6 (optional)	Row 7 (optional)	Row 8 (optional)
Stage of Orifice Centroid (ft)	0.00	1.00	2.00					
Orifice Area (sq. inches)	1.60	1.60	1.60					

	Row 9 (optional)	Row 10 (optional)	Row 11 (optional)	Row 12 (optional)	Row 13 (optional)	Row 14 (optional)	Row 15 (optional)	Row 16 (optional)
Stage of Orifice Centroid (ft)								
Orifice Area (sq. inches)								

User Input: Vertical Orifice (Circular or Rectangular)

	Not Selected	Not Selected	
Invert of Vertical Orifice =	N/A	N/A	ft (relative to basin bottom at Stage = 0 ft)
Depth at top of Zone using Vertical Orifice =	N/A	N/A	ft (relative to basin bottom at Stage = 0 ft)
Vertical Orifice Diameter =	N/A	N/A	inches

Calculated Parameters for Vertical Orifice

	Not Selected	Not Selected	
Vertical Orifice Area =	N/A	N/A	ft ²
Vertical Orifice Centroid =	N/A	N/A	feet

User Input: Overflow Weir (Dropbox with Flat or Sloped Grate and Outlet Pipe OR Rectangular/Trapezoidal Weir and No Outlet Pipe)

	Zone 2 Weir	Zone 3 Weir	
Overflow Weir Front Edge Height, Ho =	2.62	4.42	ft (relative to basin bottom at Stage = 0 ft)
Overflow Weir Front Edge Length =	6.00	6.00	feet
Overflow Weir Grate Slope =	4.00	4.00	H:V
Horiz. Length of Weir Sides =	6.00	6.00	feet
Overflow Grate Type =	Type C Grate	Type C Grate	
Debris Clogging % =	30%	30%	%

Calculated Parameters for Overflow Weir

	Zone 2 Weir	Zone 3 Weir	
Height of Grate Upper Edge, H _g =	4.12	5.92	feet
Overflow Weir Slope Length =	6.18	6.18	feet
Grate Open Area / 100-yr Orifice Area =	58.46	40.33	
Overflow Grate Open Area w/o Debris =	25.83	25.83	ft ²
Overflow Grate Open Area w/ Debris =	18.08	18.08	ft ²

User Input: Outlet Pipe w/ Flow Restriction Plate (Circular Orifice, Restrictor Plate, or Rectangular Orifice)

	Zone 2 Circular	Zone 3 Restrictor	
Depth to Invert of Outlet Pipe =	2.74	2.74	ft (distance below basin bottom at Stage = 0 ft)
Circular Orifice Diameter or Pipe Diameter =	9.00	12.00	inches
Restrictor Plate Height Above Pipe Invert =		9.12	inches

Calculated Parameters for Outlet Pipe w/ Flow Restriction Plate

	Zone 2 Circular	Zone 3 Restrictor	
Outlet Orifice Area =	0.44	0.64	ft ²
Outlet Orifice Centroid =	0.38	0.42	feet
Half-Central Angle of Restrictor Plate on Pipe =	N/A	2.12	radians

User Input: Emergency Spillway (Rectangular or Trapezoidal)

Spillway Invert Stage =	7.12	ft (relative to basin bottom at Stage = 0 ft)
Spillway Crest Length =	10.00	feet
Spillway End Slopes =	21.00	H:V
Freeboard above Max Water Surface =	0.41	feet

Calculated Parameters for Spillway

Spillway Design Flow Depth =	0.84	feet
Stage at Top of Freeboard =	8.37	feet
Basin Area at Top of Freeboard =	1.14	acres
Basin Volume at Top of Freeboard =	3.99	acre-ft

Routed Hydrograph Results

The user can override the default CUHP hydrographs and runoff volumes by entering new values in the Inflow Hydrographs table (Columns W through AF).

	WQCV	EURV	2 Year	5 Year	10 Year	25 Year	50 Year	100 Year	500 Year
Design Storm Return Period =									
One-Hour Rainfall Depth (in) =	N/A	N/A	0.99	1.39	1.64	1.98	2.31	2.60	3.08
CUHP Runoff Volume (acre-ft) =	0.449	1.264	1.008	1.520	1.849	2.312	2.753	3.155	3.798
Inflow Hydrograph Volume (acre-ft) =	N/A	N/A	1.008	1.520	1.849	2.312	2.753	3.155	3.798
CUHP Predevelopment Peak Q (cfs) =	N/A	N/A	0.7	5.1	7.6	13.7	17.9	22.6	28.9
OPTIONAL Override Predevelopment Peak Q (cfs) =	N/A	N/A							
Predevelopment Unit Peak Flow, q (cfs/acre) =	N/A	N/A	0.04	0.33	0.50	0.89	1.16	1.47	1.87
Peak Inflow Q (cfs) =	N/A	N/A	18.2	27.1	31.9	40.7	48.3	56.6	67.8
Peak Outflow Q (cfs) =	0.4	5.4	3.7	5.2	5.3	6.0	8.3	8.5	8.8
Ratio Peak Outflow to Predevelopment Q =	N/A	N/A	N/A	1.0	0.7	0.4	0.5	0.4	0.3
Structure Controlling Flow =	Overflow Weir 1	Outlet Plate 1	Overflow Weir 1	Outlet Plate 1	Outlet Plate 1	Overflow Weir 2	Outlet Plate 2	Outlet Plate 2	Outlet Plate 2
Max Velocity through Grate 1 (fps) =	0.01	0.20	0.13	0.2	0.2	0.2	0.2	0.2	0.2
Max Velocity through Grate 2 (fps) =	N/A	N/A	N/A	N/A	N/A	0.0	0.1	0.1	0.1
Time to Drain 97% of Inflow Volume (hours) =	40	38	40	38	37	36	35	34	33
Time to Drain 99% of Inflow Volume (hours) =	43	43	45	44	44	43	43	42	42
Maximum Ponding Depth (ft) =	2.72	4.07	3.14	3.61	3.96	4.56	4.91	5.33	5.89
Area at Maximum Ponding Depth (acres) =	0.46	0.73	0.56	0.64	0.71	0.79	0.85	0.90	0.97
Maximum Volume Stored (acre-ft) =	0.453	1.268	0.669	0.946	1.182	1.632	1.919	2.286	2.811

DETENTION BASIN OUTLET STRUCTURE DESIGN

MHFD-Detention, Version 4.06 (July 2022)

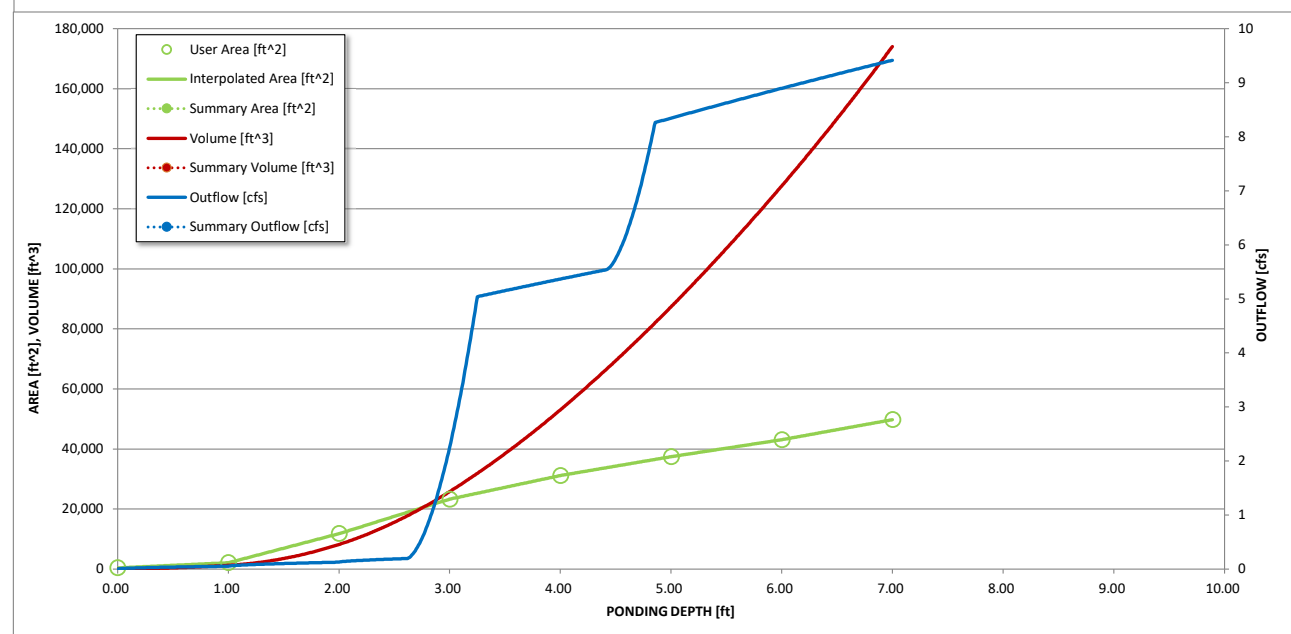
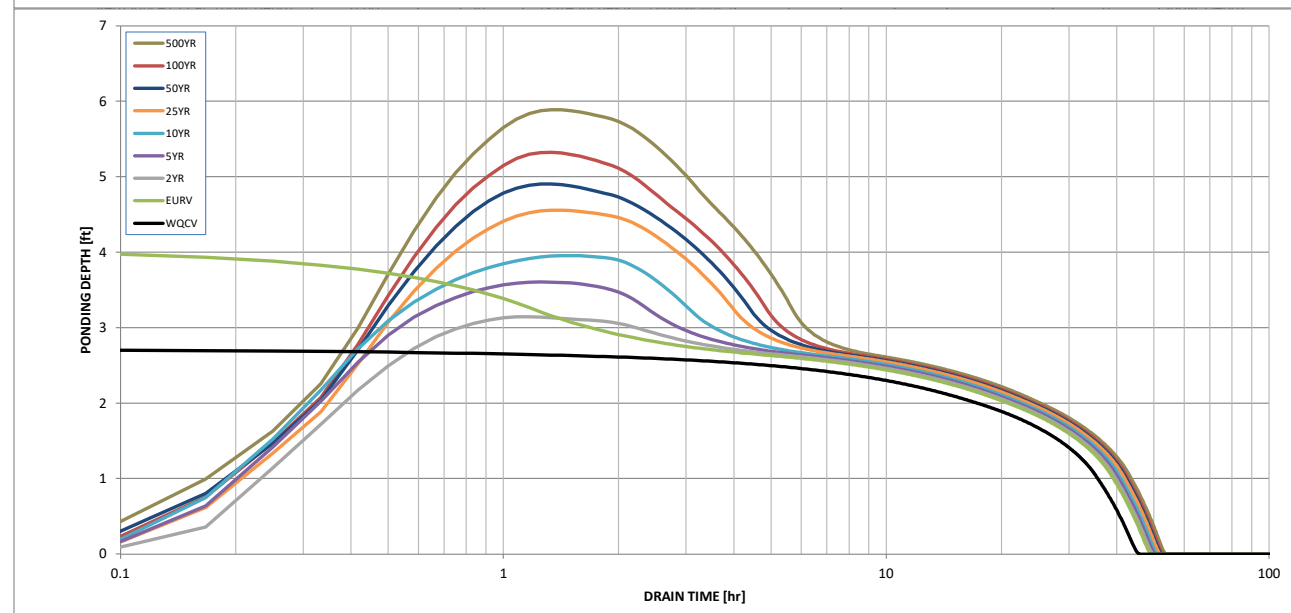
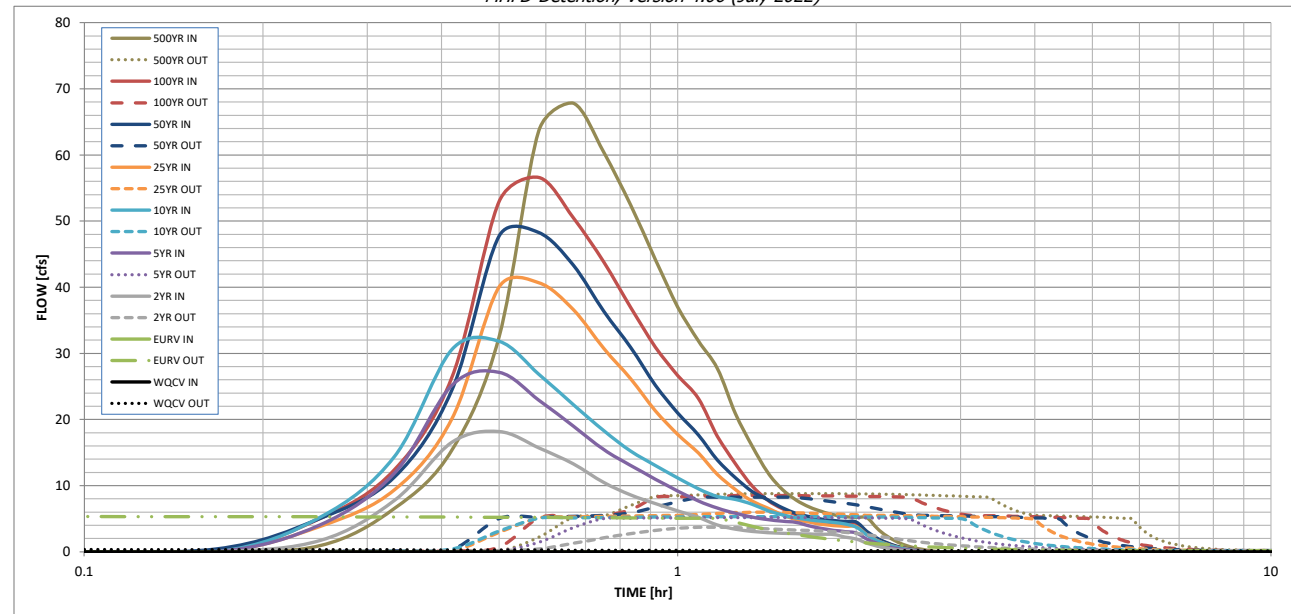

S-A-V-D Chart Axis Override	X-axis	Left Y-Axis	Right Y-Axis
minimum bound			
maximum bound			

DETENTION BASIN STAGE-STORAGE TABLE BUILDER

MHFD-Detention, Version 4.06 (July 2022)

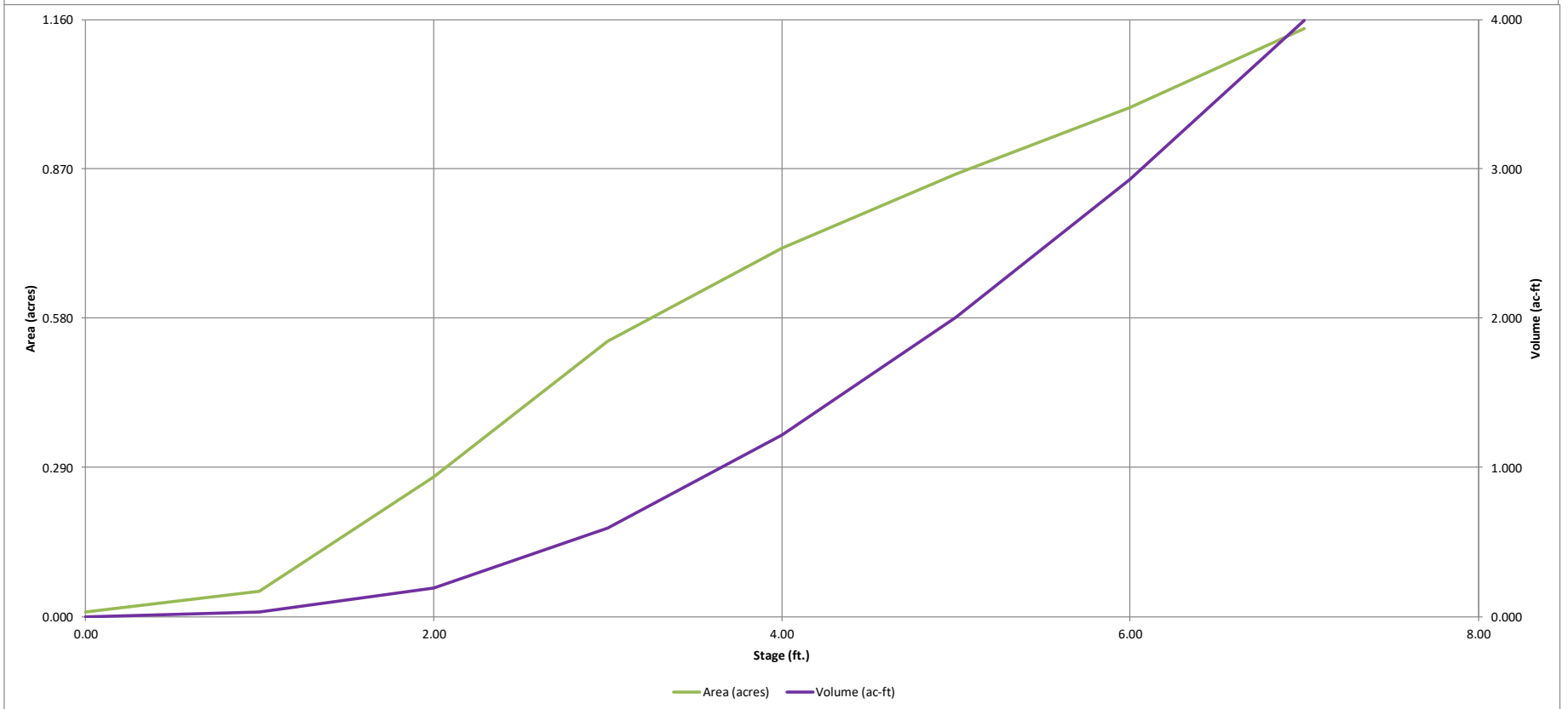
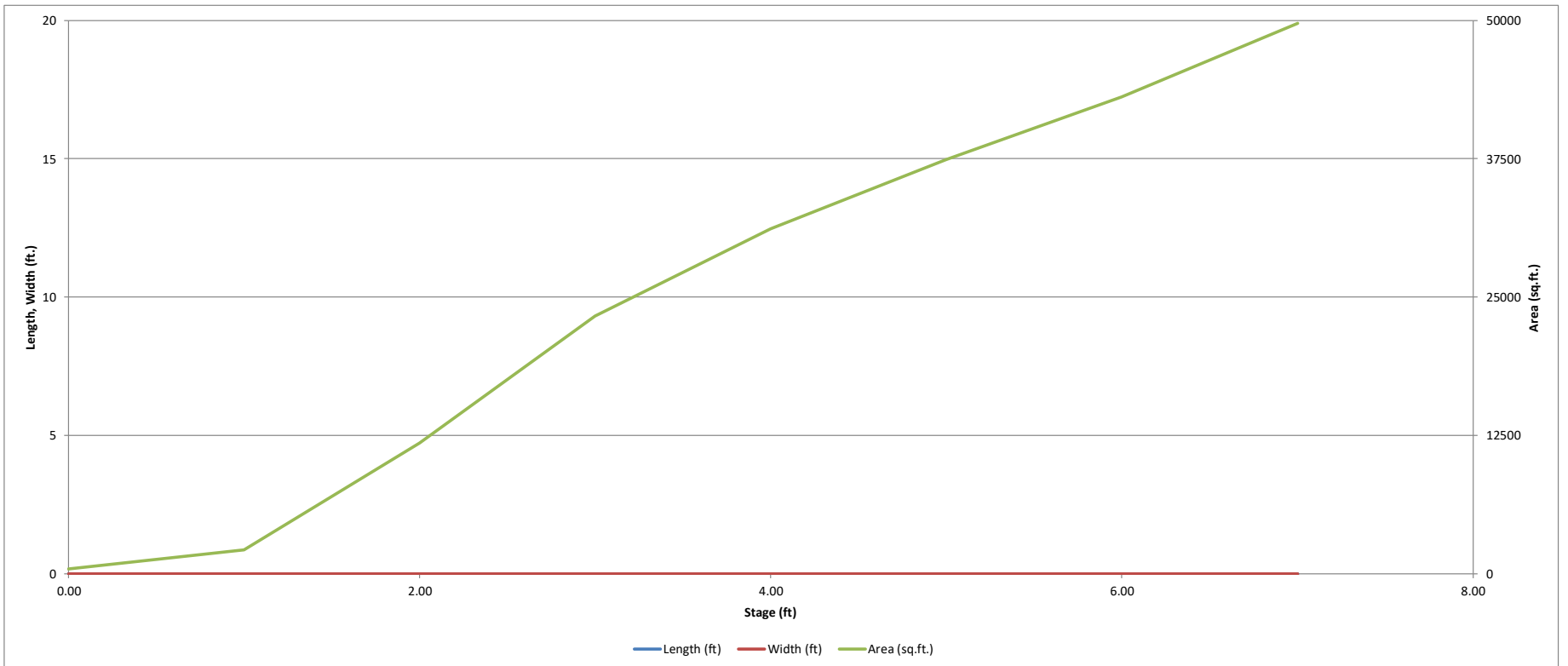

DETENTION BASIN OUTLET STRUCTURE DESIGN

MHFD- Detention, Version 4.06 (July 2022)

Project: AdventHealth Parker - South Pond B (Miro Job # 23079)

Basin ID: Proposed Tributary Basins (Includes Offsite Basins)

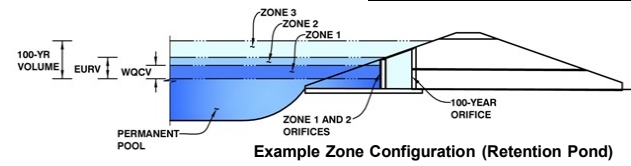

	Estimated Stage (ft)	Estimated Volume (ac-ft)	Outlet Type
Zone 1 (WQCV)	2.75	0.462	Orifice Plate
Zone 2 (EURV)	4.02	0.768	Weir&Pipe (Circular)
Zone 3 (100-year)	5.56	1.272	Weir&Pipe (Restrict)
Total (all zones)		2.502	

User Input: Orifice at Underdrain Outlet (typically used to drain WQCV in a Filtration BMP)

Underdrain Orifice Invert Depth =	N/A	ft (distance below the filtration media surface)
Underdrain Orifice Diameter =	N/A	inches

Calculated Parameters for Underdrain

Underdrain Orifice Area =	N/A	ft ²
Underdrain Orifice Centroid =	N/A	feet

User Input: Orifice Plate with one or more orifices or Elliptical Slot Weir (typically used to drain WQCV and/or EURV in a sedimentation BMP)

Centroid of Lowest Orifice =	0.00	ft (relative to basin bottom at Stage = 0 ft)
Depth at top of Zone using Orifice Plate =	2.72	ft (relative to basin bottom at Stage = 0 ft)
Orifice Plate: Orifice Vertical Spacing =	12.00	inches
Orifice Plate: Orifice Area per Row =	1.60	sq. inches (diameter = 1-7/16 inches)

Calculated Parameters for Plate

WQ Orifice Area per Row =	1.111E-02	ft ²
Elliptical Half-Width =	N/A	feet
Elliptical Slot Centroid =	N/A	feet
Elliptical Slot Area =	N/A	ft ²

User Input: Stage and Total Area of Each Orifice Row (numbered from lowest to highest)

	Row 1 (required)	Row 2 (optional)	Row 3 (optional)	Row 4 (optional)	Row 5 (optional)	Row 6 (optional)	Row 7 (optional)	Row 8 (optional)
Stage of Orifice Centroid (ft)	0.00	1.00	2.00					
Orifice Area (sq. inches)	1.60	1.60	1.60					

	Row 9 (optional)	Row 10 (optional)	Row 11 (optional)	Row 12 (optional)	Row 13 (optional)	Row 14 (optional)	Row 15 (optional)	Row 16 (optional)
Stage of Orifice Centroid (ft)								
Orifice Area (sq. inches)								

User Input: Vertical Orifice (Circular or Rectangular)

	Not Selected	Not Selected	
Invert of Vertical Orifice =	N/A	N/A	ft (relative to basin bottom at Stage = 0 ft)
Depth at top of Zone using Vertical Orifice =	N/A	N/A	ft (relative to basin bottom at Stage = 0 ft)
Vertical Orifice Diameter =	N/A	N/A	inches

Calculated Parameters for Vertical Orifice

	Not Selected	Not Selected	
Vertical Orifice Area =	N/A	N/A	ft ²
Vertical Orifice Centroid =	N/A	N/A	feet

User Input: Overflow Weir (Dropbox with Flat or Sloped Grate and Outlet Pipe OR Rectangular/Trapezoidal Weir and No Outlet Pipe)

	Zone 2 Weir	Zone 3 Weir	
Overflow Weir Front Edge Height, Ho =	2.62	4.42	ft (relative to basin bottom at Stage = 0 ft)
Overflow Weir Front Edge Length =	6.00	6.00	feet
Overflow Weir Grate Slope =	4.00	4.00	H:V
Horiz. Length of Weir Sides =	6.00	6.00	feet
Overflow Grate Type =	Type C Grate	Type C Grate	
Debris Clogging % =	30%	30%	%

Calculated Parameters for Overflow Weir

	Zone 2 Weir	Zone 3 Weir	
Height of Grate Upper Edge, H _g =	4.12	5.92	feet
Overflow Weir Slope Length =	6.18	6.18	feet
Grate Open Area / 100-yr Orifice Area =	58.46	40.33	
Overflow Grate Open Area w/o Debris =	25.83	25.83	ft ²
Overflow Grate Open Area w/ Debris =	18.08	18.08	ft ²

User Input: Outlet Pipe w/ Flow Restriction Plate (Circular Orifice, Restrictor Plate, or Rectangular Orifice)

	Zone 2 Circular	Zone 3 Restrictor	
Depth to Invert of Outlet Pipe =	2.74	2.74	ft (distance below basin bottom at Stage = 0 ft)
Circular Orifice Diameter or Pipe Diameter =	9.00	12.00	inches
Restrictor Plate Height Above Pipe Invert =		9.12	inches

Calculated Parameters for Outlet Pipe w/ Flow Restriction Plate

	Zone 2 Circular	Zone 3 Restrictor	
Outlet Orifice Area =	0.44	0.64	ft ²
Outlet Orifice Centroid =	0.38	0.42	feet
Half-Central Angle of Restrictor Plate on Pipe =	N/A	2.12	radians

User Input: Emergency Spillway (Rectangular or Trapezoidal)

Spillway Invert Stage =	7.12	ft (relative to basin bottom at Stage = 0 ft)
Spillway Crest Length =	10.00	feet
Spillway End Slopes =	21.00	H:V
Freeboard above Max Water Surface =	0.41	feet

Calculated Parameters for Spillway

Spillway Design Flow Depth =	1.05	feet
Stage at Top of Freeboard =	8.58	feet
Basin Area at Top of Freeboard =	1.14	acres
Basin Volume at Top of Freeboard =	3.99	acre-ft

Routed Hydrograph Results

The user can override the default CUHP hydrographs and runoff volumes by entering new values in the Inflow Hydrographs table (Columns W through AF).

	WQCV	EURV	2 Year	5 Year	10 Year	25 Year	50 Year	100 Year	500 Year
Design Storm Return Period =	N/A	N/A	0.99	1.39	1.64	1.98	2.31	2.60	3.08
One-Hour Rainfall Depth (in) =	N/A	N/A	1.032	1.844	2.404	3.285	4.073	4.859	6.020
CUHP Runoff Volume (acre-ft) =	N/A	N/A	1.032	1.844	2.404	3.285	4.073	4.859	6.020
Inflow Hydrograph Volume (acre-ft) =	N/A	N/A	1.6	11.9	17.6	31.2	40.9	50.4	64.5
CUHP Predevelopment Peak Q (cfs) =	N/A	N/A	0.06	0.42	0.62	1.11	1.45	1.79	2.28
OPTIONAL Override Predevelopment Peak Q (cfs) =	N/A	N/A	18.1	34.9	43.6	60.8	74.8	89.6	110.0
Predevelopment Unit Peak Flow, q (cfs/acre) =	N/A	N/A	4.1	5.4	6.2	8.6	9.0	9.4	9.4
Peak Inflow Q (cfs) =	N/A	N/A	N/A	N/A	0.5	0.4	0.3	0.2	0.1
Peak Outflow Q (cfs) =	0.5	5.4	N/A	N/A	0.2	0.2	0.2	0.2	0.2
Ratio Peak Outflow to Predevelopment Q =	N/A	N/A	N/A	N/A	0.2	0.1	0.1	0.1	0.1
Structure Controlling Flow =	Overflow Weir 1	Outlet Plate 1	Overflow Weir 1	Outlet Plate 1	Overflow Weir 2	Outlet Plate 2	Outlet Plate 2	Outlet Plate 2	N/A
Max Velocity through Grate 1 (fps) =	0.01	0.20	0.15	0.2	0.2	0.2	0.2	0.2	0.2
Max Velocity through Grate 2 (fps) =	N/A	N/A	N/A	N/A	0.0	0.1	0.1	0.1	0.1
Time to Drain 97% of Inflow Volume (hours) =	40	38	39	37	36	34	32	31	29
Time to Drain 99% of Inflow Volume (hours) =	43	43	45	44	43	42	42	42	42
Maximum Ponding Depth (ft) =	2.74	4.02	3.18	4.04	4.61	5.48	6.17	6.88	7.00
Area at Maximum Ponding Depth (acres) =	0.47	0.72	0.57	0.72	0.80	0.92	1.01	1.12	1.14
Maximum Volume Stored (acre-ft) =	0.462	1.232	0.686	1.239	1.672	2.423	3.089	3.848	3.995

DETENTION BASIN OUTLET STRUCTURE DESIGN

MHFD-Detention, Version 4.06 (July 2022)

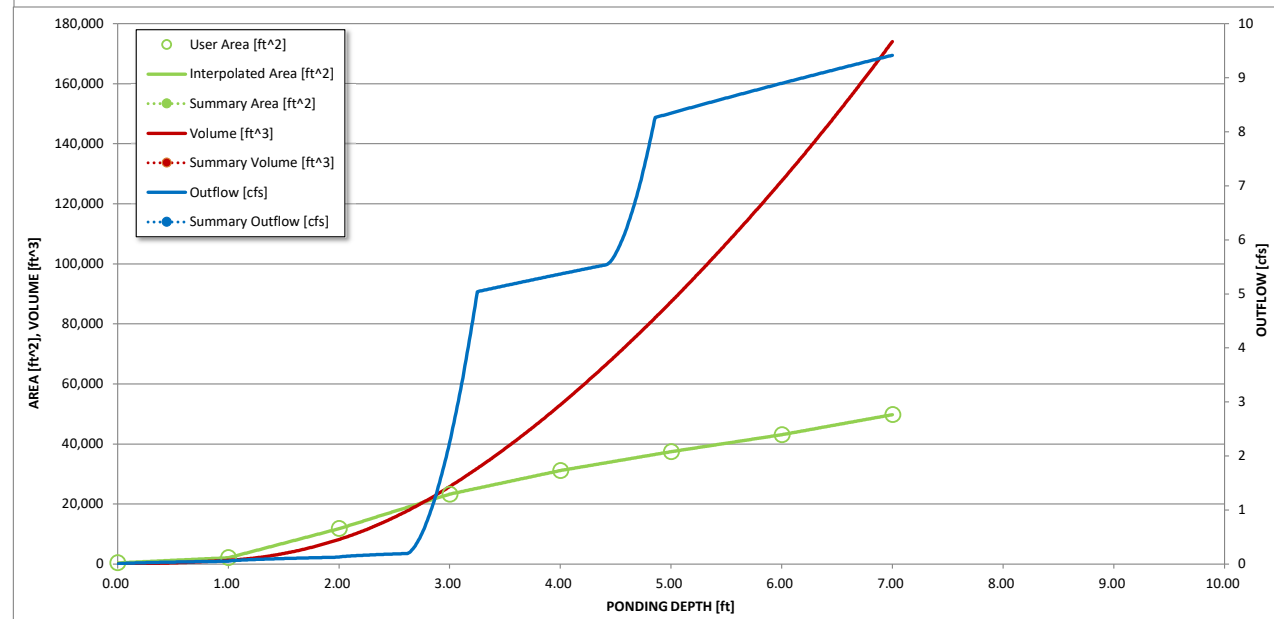
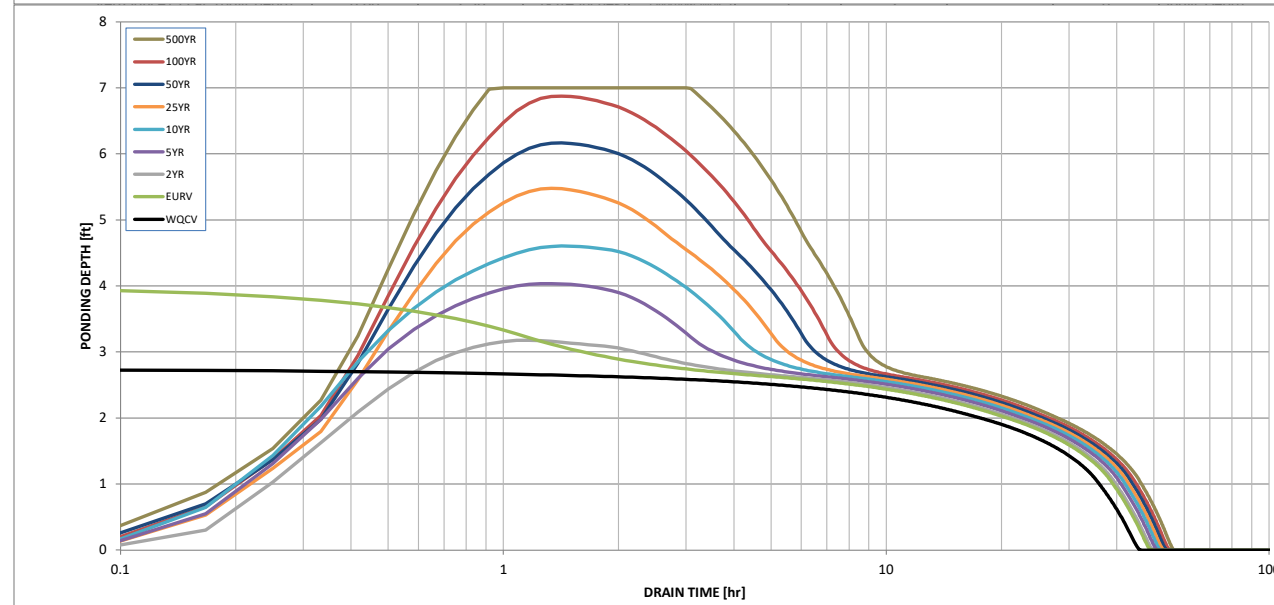
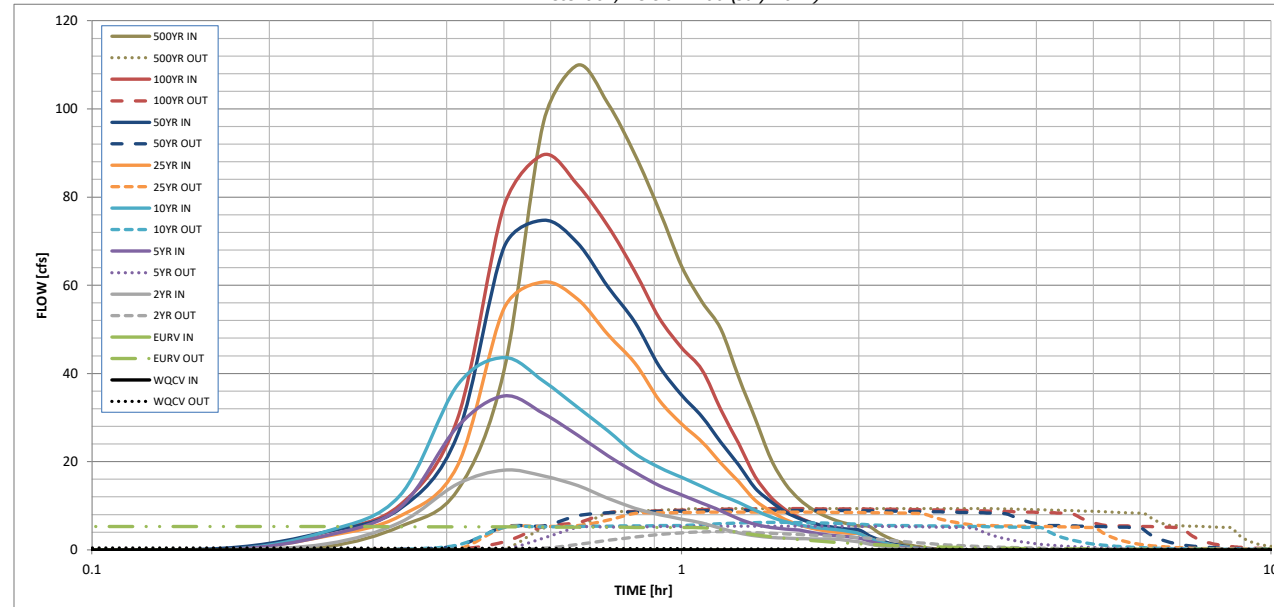

S-A-V-D Chart Axis Override	X-axis	Left Y-Axis	Right Y-Axis
minimum bound			
maximum bound			

DETENTION BASIN STAGE-STORAGE TABLE BUILDER

DETENTION BASIN STAGE-STORAGE TABLE BUILDER

MHFD-Detention, Version 4.06 (July 2022)

MHFD-Detention, Version 4.06 (July 2022)

Project: Advent Health Parker - Southwest Pond A (Miro Job # 23079)

Basin ID: Existing Tributary A Basins (Includes Offsite Basins) - Per PAH Parking Lot Expansion (Miro Job # 15029) Drainage Report

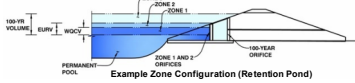

Watershed Information

Selected BMP Type =	EDB
Watershed Area =	25.40 acres
Watershed Length =	1,780 ft
Watershed Length to Centroid =	500 ft
Watershed Slope =	0.033 ft/ft
Watershed Imperviousness =	61.00% percent
Percentage Hydrologic Soil Group A =	26.3% percent
Percentage Hydrologic Soil Group B =	6.9% percent
Percentage Hydrologic Soil Groups C/D =	66.9% percent
Target WQCV Drain Time =	40.0 hours
Location for 1-hr Rainfall Depths =	Parker - Town Hall

Define Zones and Basin Geometry

Zone 1 Volume (WQCV) =	0.507 acre-feet
Zone 2 Volume (EURV - Zone 1) =	1.100 acre-feet
Zone 3 Volume (User Defined - Zones 1 & 2) =	0.385 acre-feet
Total Detention Basin Volume =	1.993 acre-feet
Initial Surcharge Volume (SV) =	user ft ³
Initial Surcharge Depth (SD) =	user ft
Total Available Detention Depth (H _{av}) =	user ft
Depth of Trickle Channel (H _t) =	user ft
Slope of Trickle Channel (S _t) =	user ft/ft
Slopes of Main Basin Sides (S _m) =	user H:V
Basin Length-to-Width Ratio (R _m) =	user
Initial Surcharge Area (A _{sv}) =	user ft ²
Surcharge Volume Length (L _{sv}) =	user ft
Surcharge Volume Width (W _{sv}) =	user ft
Depth of Basin Floor (H _b) =	user ft
Length of Basin Floor (L _b) =	user ft
Width of Basin Floor (W _b) =	user ft
Area of Basin Floor (A _b) =	user ft ²
Volume of Basin Floor (V _b) =	user ft ³
Depth of Main Basin (H _m) =	user ft
Length of Main Basin (L _m) =	user ft
Width of Main Basin (W _m) =	user ft
Area of Main Basin (A _m) =	user ft ²
Volume of Main Basin (V _m) =	user ft ³
Calculated Total Basin Volume (V _{tot}) =	user acre-feet

Optional User Overrides

acre-feet	0.99
inches	1.39
inches	1.64
inches	1.98
inches	2.31
inches	2.60

Stage - Storage Description	Stage (ft)	Optional Override Stage (ft)	Length (ft)	Width (ft)	Area (ft ²)	Optional Override Area (ft ²)	Area (acre)	Volume (ft ³)	Volume (ac-ft)
Top of Micropool	0.00				150		0.003	74	0.002
	0.33				300		0.007	229	0.005
5794	0.62				677		0.140	3,650	0.084
5795	1.62				15,545		0.357	14,461	0.332
5796	2.62				17,888		0.411	31,177	0.716
5797	3.62				20,412		0.469	50,327	1.155
5798	4.62				23,480		0.539	72,273	1.659
5799	5.62				26,879		0.617	97,453	2.237
5800	6.62								

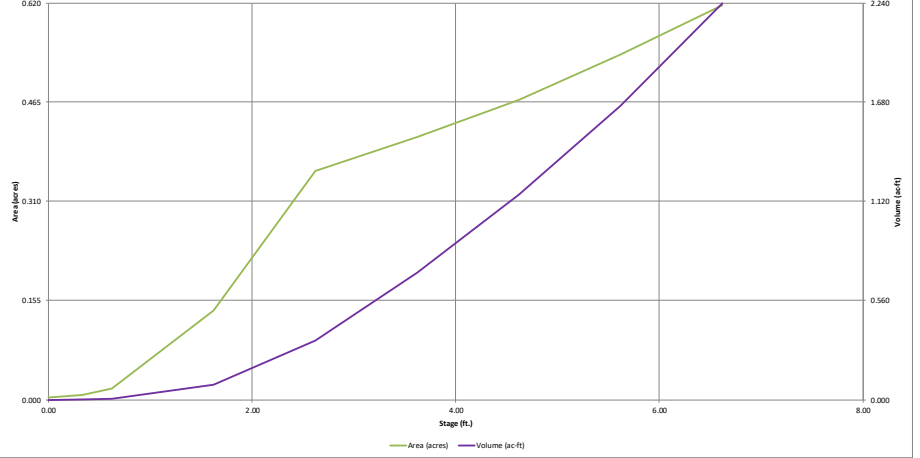
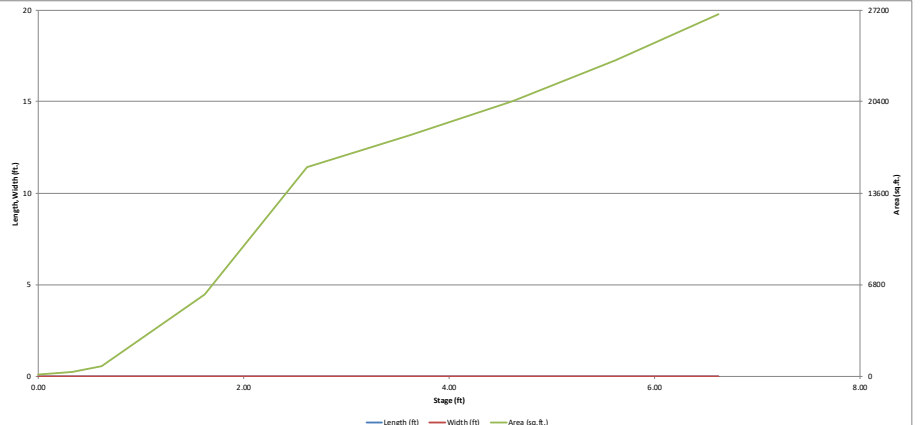

DETENTION BASIN OUTLET STRUCTURE DESIGN
 MHPD-Detention, Version 4.06 (July 2022)

Project: Advent Health Parker - Southwest Pond A (Miro Job # 23979)
 Basin ID: Existing Tributary A Basins (Includes Offsite Basins) - Per PAH Parking Lot Expansion (Miro Job # 15029) Drainage Report

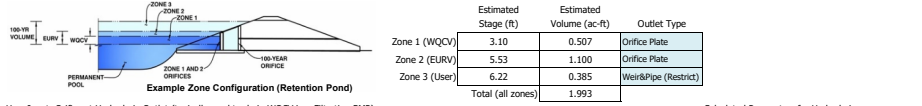

Zone	Estimated Stage (ft)	Estimated Volume (ac-ft)	Outlet Type
Zone 1 (WQCV)	3.10	0.507	Orifice Plate
Zone 2 (EURV)	5.53	1.100	Orifice Plate
Zone 3 (User)	6.22	0.385	Weir/Pipe (Restrict)
Total (all zones)		1.993	

User Input: Underdrain Outlet (Typically used to drain WQCV in a Filtration BMP)

Underdrain Orifice Invert Depth =	N/A	ft (distance below the filtration media surface)	Underdrain Orifice Area =	N/A	ft ²
Underdrain Orifice Diameter =	N/A	inches	Underdrain Orifice Count =	N/A	feet

User Input: Orifice Plate with one or more orifices or Elliptical Slot Weir (Typically used to drain WQCV and/or EURV in a sedimentation BMP)

Control of Lowest Orifice =	0.00	ft (relative to basin bottom at Stage = 0 ft)	WQ Orifice Area per Row =	1.646E-02	ft ²
Depth at top of Zone using Orifice Plate =	5.00	ft (relative to basin bottom at Stage = 0 ft)	Elliptical Half-Width =	N/A	feet
Orifice Plate: Orifice Vertical Spacing =	20.00	inches	Elliptical Slot Count =	N/A	feet
Orifice Plate: Orifice Area per Row =	2.37	sq. inches (diameter = 1-3/4 inches)	Elliptical Slot Area =	N/A	ft ²

User Input: Stage and Total Area of Each Orifice Row (numbered from lowest to highest)

Row	Stage (ft)	Orifice Area (sq. inches)
Row 1 (required)	0.00	1.70
Row 2 (optional)	2.37	3.40
Row 3 (optional)	2.37	2.37
Row 4 (optional)		
Row 5 (optional)		
Row 6 (optional)		
Row 7 (optional)		
Row 8 (optional)		
Row 9 (optional)		
Row 10 (optional)		
Row 11 (optional)		
Row 12 (optional)		
Row 13 (optional)		
Row 14 (optional)		
Row 15 (optional)		
Row 16 (optional)		

User Input: Vertical Orifice (Circular or Rectangular)

Invert of Vertical Orifice =	Not Selected	N/A	ft (relative to basin bottom at Stage = 0 ft)	Vertical Orifice Area =	Not Selected	ft ²
Depth at top of Zone using Vertical Orifice =	N/A	N/A	ft (relative to basin bottom at Stage = 0 ft)	Vertical Orifice Count =	N/A	feet
Vertical Orifice Diameter =	N/A	N/A	inches			

User Input: Overflow Weir (Dropbox with Flat or Sloped Grate and Outlet Pipe OR Rectangular/Trapezoidal Weir and No Outlet Pipe)

Overflow Weir From Edge Height, H _o =	5.47	ft (relative to basin bottom at Stage = 0 ft)	Overflow Weir Slope Length =	2.96	ft
Overflow Weir Front Edge Length =	12.00	ft	Grate Open Area / 100-yr Orifice Area =	8.20	ft ²
Overflow Weir Grade Slope =	4.00	H:V	Overflow Grate Open Area w/o Debris =	24.74	ft ²
Horiz. Length of Weir Sides =	2.00	ft	Overflow Grate Open Area w/ Debris =	24.74	ft ²
Overflow Grate Type =	No Grate				
Debris Clogging % =	0%				

User Input: Outlet Pipe w/ Flow Restriction Plate (Circular Orifice, Restrictor Plate, or Rectangular Orifice)

Depth to Invert of Outlet Pipe =	0.00	ft (distance below basin bottom at Stage = 0 ft)	Outlet Orifice Area =	3.02	ft ²
Outlet Pipe Diameter =	24.00	inches	Outlet Orifice Count =	0.96	feet
Restrictor Plate Height Above Pipe Invert =	22.00	inches	Half-Central Angle of Restrictor Plate on Pipe =	2.56	radians

User Input: Emergency Spillway (Rectangular or Trapezoidal)

Spillway Invert Stage =	6.26	ft (relative to basin bottom at Stage = 0 ft)	Spillway Design Flow Depth =	2.07	feet
Spillway Crest Length =	4.00	feet	Stage at Top of Freeboard =	9.33	feet
Spillway End Slopes =	3:50	H:V	Basin Area at Top of Freeboard =	0.62	acres
Freeboard above Max Water Surface =	1.00	feet	Basin Volume at Top of Freeboard =	2.24	acre-ft

Routed Hydrograph Results

	WQCV	EURV	2 Year	5 Year	10 Year	25 Year	50 Year	100 Year	500 Year
Design Storm Return Period	N/A	N/A	0.99	1.39	1.64	1.98	2.31	2.60	2.98
One-Hour Rainfall Depth (in)	N/A	N/A	1.171	1.844	2.308	3.108	3.795	4.484	5.510
CLHP Runoff Volume (acre-ft)	0.507	1.608	1.171	1.844	2.308	3.108	3.795	4.484	5.510
Inflow Hydrograph Peak Q (cfs)	N/A	N/A	0.4	6.0	10.5	23.1	31.4	39.7	51.5
OPTIONAL Override Prerddevelopment Peak Q (cfs)	N/A	N/A							
Prerddevelopment Unit Peak Flow, q (cfs/acre)	N/A	N/A	0.01	0.24	0.41	0.91	1.24	1.56	2.03
Peak Inflow Q (cfs)	N/A	N/A	22.1	36.0	44.2	60.2	73.5	88.2	107.5
Peak Outflow Q (cfs)	0.2	0.7	0.4	2.6	6.7	20.7	32.9	35.8	35.8
Ratio Peak Outflow to Prerddevelopment Q	N/A	N/A	N/A	0.4	0.6	0.9	1.0	0.9	0.7
Structure Controlling Flow =	Plate	Overflow Weir 1	Plate	Overflow Weir 1	Overflow Weir 1	Spillway	Spillway	N/A	N/A
Max Velocity through Gate 1 (fps)	N/A	0.01	N/A	0.1	0.2	0.8	1.2	1.3	1.3
Max Velocity through Gate 2 (fps)	N/A	N/A	N/A	N/A	N/A	N/A	N/A	N/A	N/A
Time to Drain 97% of Inflow Volume (hours)	39	70	61	72	71	68	56	54	62
Time to Drain 99% of Inflow Volume (hours)	39	75	64	78	77	76	75	74	73
Maximum Ponding Depth (ft)	3.10	5.53	4.53	5.68	5.88	6.32	6.57	6.62	6.62
Area at Maximum Ponding Depth (acres)	0.38	0.53	0.46	0.54	0.56	0.59	0.61	0.62	0.62
Maximum Volume Stored (acre-ft)	0.509	1.611	1.109	1.686	1.802	2.096	2.206	2.237	2.237

The user can override the default CLHP hydrographs and runoff volumes by entering new values in the Inflow Hydrographs table (Columns W through AF)

	W	X	Y	Z	AA	AB	AC	AD	AE	AF
Source	CLHP	CLHP	CLHP	CLHP	CLHP	CLHP	CLHP	CLHP	CLHP	CLHP
Time Interval	5.00 min									
TIME	0:00:00	0:05:00	0:10:00	0:15:00	0:20:00	0:25:00	0:30:00	0:35:00	0:40:00	0:45:00
WQCV [cfs]	0.00	0.00	0.00	0.00	0.00	0.00	0.00	0.00	0.00	0.00
EURV [cfs]	0.00	0.00	0.00	0.00	0.00	0.00	0.00	0.00	0.00	0.00
2 Year [cfs]	0.00	0.00	0.00	0.00	0.00	0.00	0.00	0.00	0.00	0.00
5 Year [cfs]	0.00	0.00	0.00	0.00	0.00	0.00	0.00	0.00	0.00	0.00
10 Year [cfs]	0.00	0.00	0.00	0.00	0.00	0.00	0.00	0.00	0.00	0.00
25 Year [cfs]	0.00	0.00	0.00	0.00	0.00	0.00	0.00	0.00	0.00	0.00
50 Year [cfs]	0.00	0.00	0.00	0.00	0.00	0.00	0.00	0.00	0.00	0.00
100 Year [cfs]	0.00	0.00	0.00	0.00	0.00	0.00	0.00	0.00	0.00	0.00
500 Year [cfs]	0.00	0.00	0.00	0.00	0.00	0.00	0.00	0.00	0.00	0.00

DETENTION BASIN OUTLET STRUCTURE DESIGN
 MHPD-Detention, Version 4.06 (July 2022)

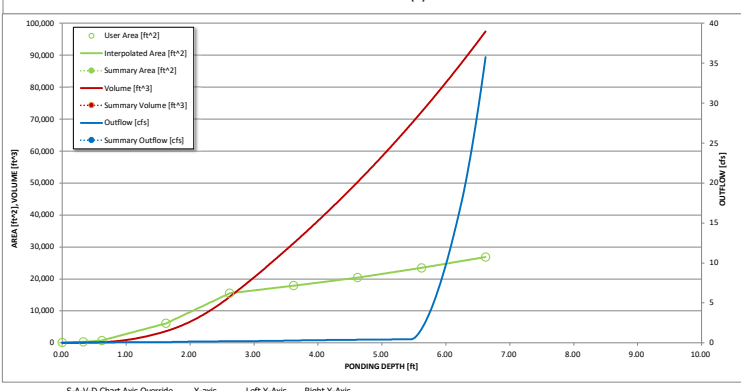
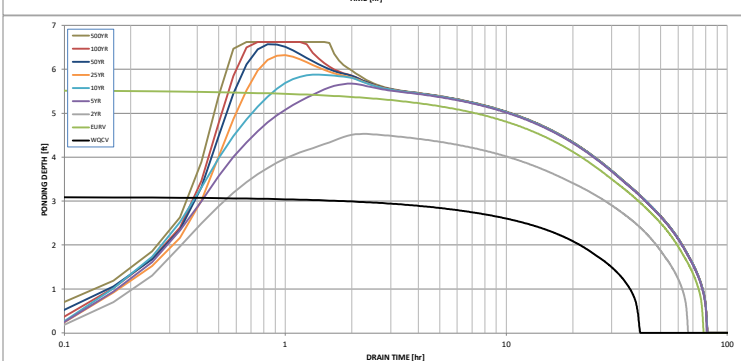
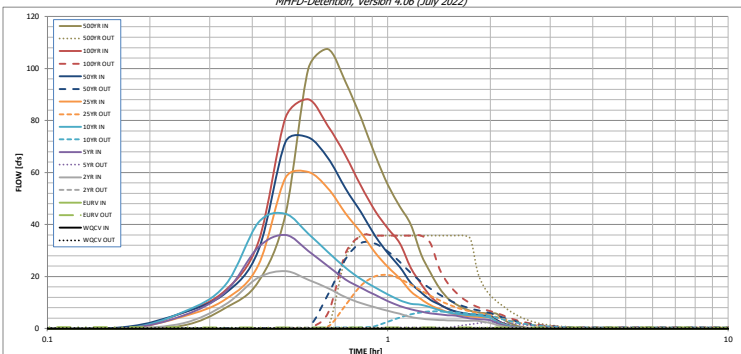

DETENTION BASIN OUTLET STRUCTURE DESIGN
 MHPD-Detention, Version 4.06 (July 2022)

Outflow Hydrograph Worksheet Filename:

Inflow Hydrographs
 The user can override the calculated inflow hydrographs from this workbook with inflow hydrographs developed in a separate program.

Time Interval	SOURCE	CLHP	CLHP	CLHP	CLHP	CLHP	CLHP	CLHP	CLHP	
	TIME	WQCV [cfs]	EURV [cfs]	2 Year [cfs]	5 Year [cfs]	10 Year [cfs]	25 Year [cfs]	50 Year [cfs]	100 Year [cfs]	500 Year [cfs]
5.00 min	0:00:00	0.00	0.00	0.00	0.00	0.00	0.00	0.00	0.00	0.00
	0:05:00	0.00	0.00	0.00	0.00	0.00	0.00	0.00	0.00	0.00
	0:10:00	0.00	0.00	0.00	0.00	0.00	0.00	0.00	0.00	0.00
	0:15:00	0.00	0.00	0.00	0.00	0.00	0.00	0.00	0.00	0.00
	0:20:00	0.00	0.00	0.00	0.00	0.00	0.00	0.00	0.00	0.00
	0:25:00	0.00	0.00	0.00	0.00	0.00	0.00	0.00	0.00	0.00
	0:30:00	0.00	0.00	0.00	0.00	0.00	0.00	0.00	0.00	0.00
	0:35:00	0.00	0.00	0.00	0.00	0.00	0.00	0.00	0.00	0.00
	0:40:00	0.00	0.00	0.00	0.00	0.00	0.00	0.00	0.00	0.00
	0:45:00	0.00	0.00	0.00	0.00	0.00	0.00	0.00	0.00	0.00
	0:50:00	0.00	0.00	0.00	0.00	0.00	0.00	0.00	0.00	0.00
	0:55:00	0.00	0.00	0.00	0.00	0.00	0.00	0.00	0.00	0.00
	1:00:00	0.00	0.00	0.00	0.00	0.00	0.00	0.00	0.00	0.00
	1:05:00	0.00	0.00	0.00	0.00	0.00	0.00	0.00	0.00	0.00
	1:10:00	0.00	0.00	0.00	0.00	0.00	0.00	0.00	0.00	0.00
	1:15:00	0.00	0.00	0.00	0.00	0.00	0.00	0.00	0.00	0.00
	1:20:00	0.00	0.00	0.00	0.00	0.00	0.00	0.00	0.00	0.00
	1:25:00	0.00	0.00	0.00	0.00	0.00	0.00	0.00	0.00	0.00
	1:30:00	0.00	0.00	0.00	0.00	0.00	0.00	0.00	0.00	0.00
	1:35:00	0.00	0.00	0.00	0.00	0.00	0.00	0.00	0.00	0.00
	1:40:00	0.00	0.00	0.00	0.00	0.00	0.00	0.00	0.00	0.00
	1:45:00	0.00	0.00	0.00	0.00	0.00	0.00	0.00	0.00	0.00
	1:50:00	0.00	0.00	0.00	0.00	0.00	0.00	0.00	0.00	0.00
	1:55:00	0.00	0.00	0.00	0.00	0.00	0.00	0.00	0.00	0.00
	2:00:00	0.00	0.00	0.00	0.00	0.00	0.00	0.00	0.00	0.00
	2:05:00	0.00	0.00	0.00	0.00	0.00	0.00	0.00	0.00	0.00
	2:10:00	0.00	0.00	0.00	0.00	0.00	0.00	0.00	0.00	0.00
	2:15:00	0.00	0.00	0.00	0.00	0.00	0.00	0.00	0.00	0.00
	2:20:00	0.00	0.00	0.00	0.00	0.00	0.00	0.00	0.00	0.00
	2:25:00	0.00	0.00	0.00	0.00	0.00	0.00	0.00	0.00	0.00
	2:30:00	0.00	0.00	0.00	0.00	0.00	0.00	0.00	0.00	0.00
	2:35:00	0.00	0.00	0.00	0.00	0.00	0.00	0.00	0.00	0.00
	2:40:00	0.00	0.00	0.00	0.00	0.00	0.00	0.00	0.00	0.00
	2:45:00	0.00	0.00	0.00	0.00	0.00	0.00	0.00	0.00	0.00
	2:50:00	0.00	0.00	0.00	0.00	0.00	0.00	0.00	0.00	0.00
	2:55:00	0.00	0.00	0.00	0.00	0.00	0.00	0.00	0.00	0.00
	3:00:00	0.00	0.00	0.00	0.00	0.00	0.00	0.00	0.00	0.00
	3:05:00	0.00	0.00	0.00	0.00	0.00	0.00	0.00	0.00	0.00
	3:10:00	0.00	0.00	0.00	0.00	0.00	0.00	0.00	0.00	0.00
	3:15:00	0.00	0.00	0.00	0.00	0.00	0.00	0.00	0.00	0.00
	3:20:00	0.00	0.00	0.00	0.00	0.00	0.00	0.00	0.00	0.00
	3:25:00	0.00	0.00	0.00	0.00	0.00	0.00	0.00	0.00	0.00
	3:30:00	0.00	0.00	0.00	0.00	0.00	0.00	0.00	0.00	0.00
	3:35:00	0.00	0.00	0.00	0.00	0.00	0.00	0.00	0.00	0.00
	3:40:00	0.00	0.00	0.00	0.00	0.00	0.00	0.00	0.00	0.00
	3:45:00	0.00	0.00	0.00	0.00	0.00	0.00	0.00	0.00	0.00
	3:50:00	0.00	0.00	0.00	0.00	0.00	0.00	0.00	0.00	0.00
	3:55:00	0.00	0.00	0.00	0.00	0.00	0.00	0.00	0.00	0.00
	4:00:00	0.00	0.00	0.00	0.00	0				

Where:

$WPRF_{14,R}$ = multiplier to reduce Q_w in Equation 7-31 for the CDOT Type R and the Denver No. 14 inlet

D_{FL} = gutter depth at flow line away from inlet depression (inches)

L = total inlet length (ft)

This reduction factor should be applied to weir equations for curb-opening inlet shallow depth interception calculations.

From the UDFCD-CSU study, empirical equations to estimate interception capacity for the CDOT Type R and the Denver No. 14 curb-opening inlets were developed and are shown in Figures 7-5 and 7-6.



Photograph 7-6. Weir performance decay can be observed in this picture as flow appears to enter only the first two inlets while exceeding the height of the upstream curb.

Weir Performance Decay

Inlets become less effective in weir flow as they grow in length. What this means is that adding inlets to reduce the depth of flow will typically not increase total capacity when the inlet is in weir flow. This is important to consider this when designing for the minor event. In an effort to meet minor event depth criteria, the system may need to be extended further upstream.

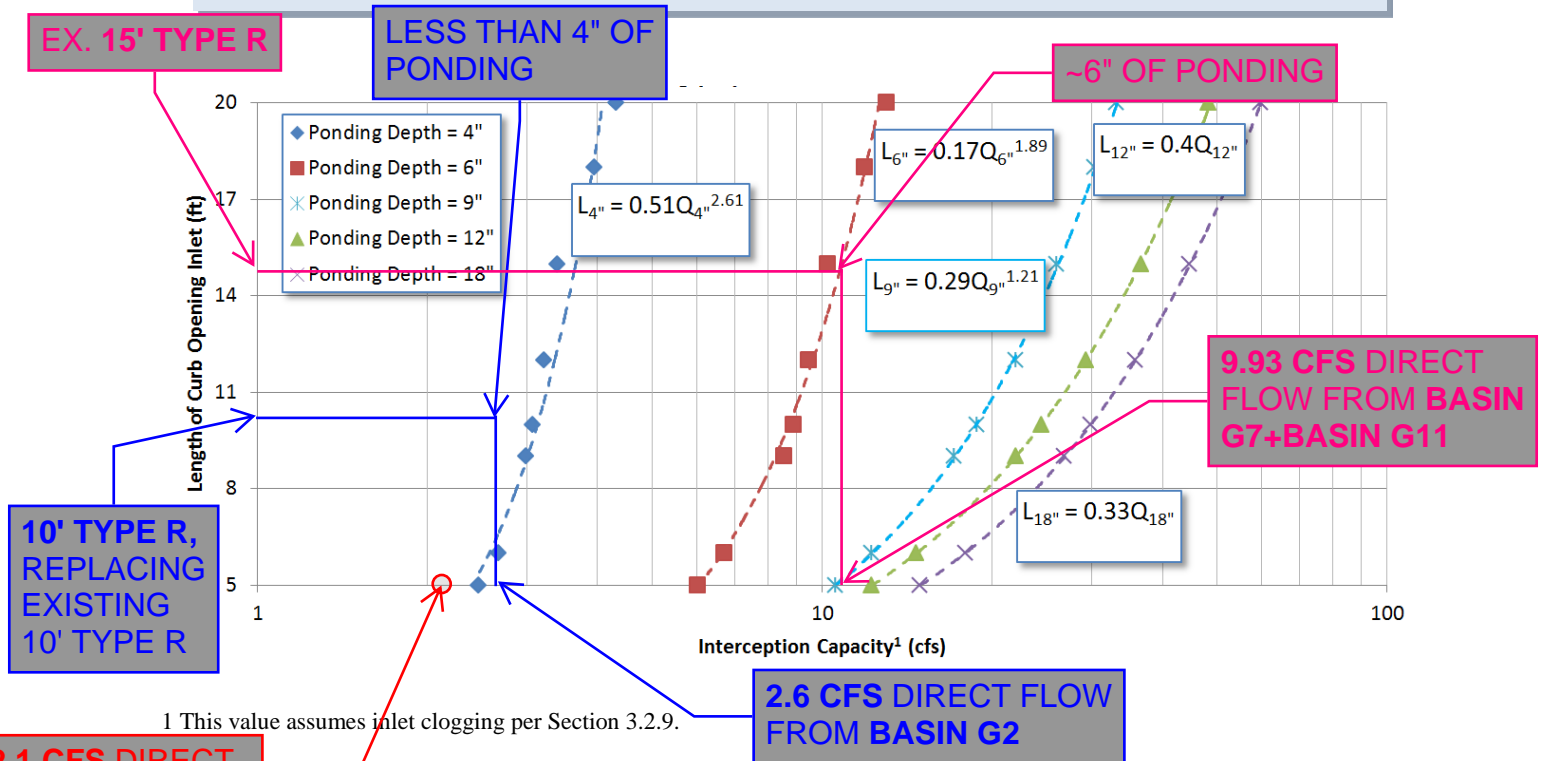
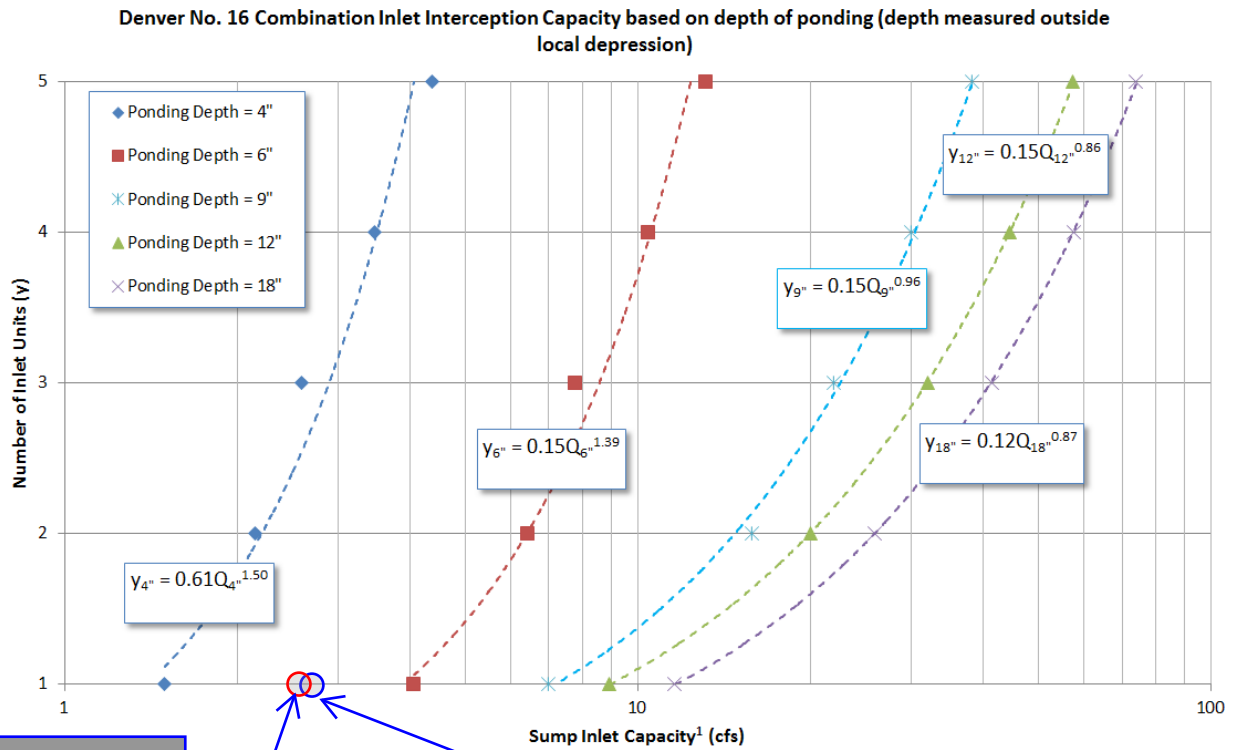

Figure 7-6. CDOT type r and Denver no. 14 interception capacity in sag

¹ This value assumes inlet clogging per Section 3.2.9.



2.55 CFS AT BASIN G8. BETWEEN 4" & 6" OF PONDING IN 100-YR STORM AT TYPE 16 INLET

times inlet clogging per Section 3.2.9.

2.64 CFS AT BASIN G4. BETWEEN 4" & 6" OF PONDING IN 100-YR STORM AT TYPE 16 INLET

Figure 7-8. Denver no. 16 intercept

3.2.7 Other Inlets in a Sump (Not Modeled in the UDFCD-CSU Study)

The hydraulic capacity of grate, curb-opening, and slotted inlets operating as weirs is expressed as:

$$Q_i = C_w L_w d^{1.5} \tag{Equation 7-37}$$

Where:

- Q_i = inlet capacity (cfs)
- C_w = weir discharge coefficient
- L_w = weir length (ft)
- d = flow depth (ft).

Values for C_w and L_w are presented in Table 7-8 for various inlet types. Note that the expressions given for curb-opening inlets without depression should be used for depressed curb-opening inlets if $L > 12$ feet.

STORMCAD LAYOUT

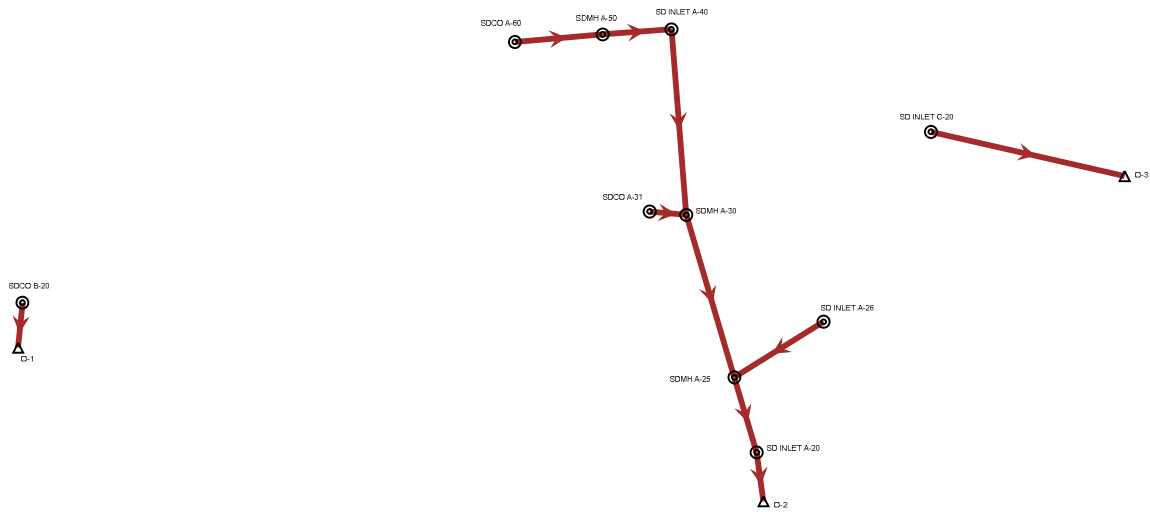

Scenairo 100-Year
FlexTable Junction Table

Label	Elevation (Ground) (ft)	Elevation (Rim) (ft)	Elevation (Invert) (ft)	Flow (Total Out) (cfs)	Depth (In) (ft)	Hydraulic Grade Line (Out) (ft)	Hydraulic Grade Line (In) (ft)
SD INLET C-20	5829.88	5829.88	5826.76	1.26	0.47	5827.23	5827.23
SDCO A-31	5829.35	5829.35	5818.43	1.73	0.59	5819.02	5819.02
SDMH A-30	5829.32	5829.32	5816.7	13.87	1.44	5818.14	5818.14
SDCO A-60	5828.32	5828.32	5818.95	1.25	0.47	5819.42	5819.42
SD INLET A-40	5827.94	5827.94	5817.36	12.14	1.31	5818.67	5818.67
SDMH A-50	5827.91	5827.91	5817.73	10.93	1.22	5818.95	5818.95
SD INLET A-26	5827.16	5827.16	5818.33	0.93	0.4	5818.73	5818.73
SDMH A-25	5826.67	5826.67	5816.08	14.8	1.49	5817.57	5817.57
SD INLET A-20	5823.92	5823.92	5815.68	14.8	1.57	5817.25	5817.25
SDCO B-20	5809.25	5809.25	5805.29	3.79	0.89	5806.18	5806.18

Scenario 100-Year
 FlexTable Junction Table

Label	Elevation (Ground) (ft)	Elevation (Rim) (ft)	Elevation (Invert) (ft)	Flow (Total Out) (cfs)	Depth (In) (ft)	Hydraulic Grade Line (Out) (ft)	Hydraulic Grade Line (In) (ft)
SD INLET C-20	5829.88	5829.88	5826.76	2.55	0.68	5827.44	5827.44
SDCO A-31	5829.35	5829.35	5818.43	3.54	2.17	5820.61	5820.61
SDMH A-30	5829.32	5829.32	5816.7	29.99	3.62	5820.32	5820.32
SDCO A-60	5828.32	5828.32	5818.95	2.65	3.17	5822.12	5822.12
SD INLET A-40	5827.94	5827.94	5817.36	26.45	4.23	5821.59	5821.59
SDMH A-50	5827.91	5827.91	5817.73	23.93	4.24	5821.98	5821.98
SD INLET A-26	5827.16	5827.16	5818.33	2.64	0.7	5819.02	5819.02
SDMH A-25	5826.67	5826.67	5816.08	32.63	2.76	5818.84	5818.84
SD INLET A-20	5823.92	5823.92	5815.68	32.63	2.35	5818.03	5818.03
SDCO B-20	5809.25	5809.25	5805.29	7.86	1.04	5806.33	5806.33

Scenario 5-Year
 FlexTable Conduit Table

Start Node	Stop Node	Invert (Start) (ft)	Invert (Stop) (ft)	Length (User Defined) (ft)	Slope (Calculated) (ft/ft)	Diameter (in)	Manning's n	Flow (cfs)	Velocity (ft/s)	Capacity (Full Flow) (cfs)	Hydraulic Grade Line (In) (ft)	Hydraulic Grade Line (Out) (ft)
SD INLET A-20	O-2	5815.86	5815.56	24.6	0.012	24	0.013	14.8	8.28	24.97	5817.25	5816.74
SDCO B-20	O-1	5805.35	5804	22.6	0.06	12	0.01	3.79	12.98	11.32	5806.18	5804.47
SD INLET C-20	O-3	5826.76	5824.78	98.8	0.02	12	0.01	1.26	6.44	6.55	5827.23	5825.08
SDCO A-31	SDMH A-30	5818.43	5818.07	18.3	0.02	10	0.01	1.73	7.11	4.03	5819.02	5818.49
SD INLET A-40	SDMH A-30	5817.36	5816.9	92.8	0.005	24	0.013	12.14	5.58	15.93	5818.67	5818.15
SDMH A-30	SDMH A-25	5816.7	5816.28	84.4	0.005	24	0.013	13.87	5.72	15.96	5818.14	5817.62
SDCO A-60	SDMH A-50	5818.95	5818.73	43.8	0.005	12	0.01	1.25	3.89	3.27	5819.42	5819.16
SDMH A-50	SD INLET A-40	5817.73	5817.56	34.3	0.005	24	0.013	10.93	5.46	15.93	5818.95	5818.75
SD INLET A-26	SDMH A-25	5818.33	5817.28	52.3	0.02	12	0.01	0.93	5.9	6.55	5818.73	5817.53
SDMH A-25	SD INLET A-20	5816.08	5815.88	39	0.005	24	0.013	14.8	5.84	16.2	5817.57	5817.27

Scenario 100-Year
 FlexTable Conduit Table

Start Node	Stop Node	Invert (Start) (ft)	Invert (Stop) (ft)	Length (User Defined) (ft)	Slope (Calculated) (ft/ft)	Diameter (in)	Manning's n	Flow (cfs)	Velocity (ft/s)	Capacity (Full Flow) (cfs)	Hydraulic Grade Line (In) (ft)	Hydraulic Grade Line (Out) (ft)
SD INLET A-20	O-2	5815.86	5815.56	24.6	0.012	24	0.013	32.63	10.39	24.97	5818.03	5817.46
SDCO B-20	O-1	5805.35	5804	22.6	0.06	12	0.01	7.86	15.57	11.32	5806.33	5804.74
SD INLET C-20	O-3	5826.76	5824.78	98.8	0.02	12	0.01	2.55	7.82	6.55	5827.44	5825.21
SDCO A-31	SDMH A-30	5818.43	5818.07	18.3	0.02	10	0.01	3.54	6.49	4.03	5820.61	5820.32
SD INLET A-40	SDMH A-30	5817.36	5816.9	92.8	0.005	24	0.013	26.45	8.42	15.93	5821.59	5820.32
SDMH A-30	SDMH A-25	5816.7	5816.28	84.4	0.005	24	0.013	29.99	9.55	15.96	5820.32	5818.84
SDCO A-60	SDMH A-50	5818.95	5818.73	43.8	0.005	12	0.01	2.65	3.37	3.27	5822.12	5821.98
SDMH A-50	SD INLET A-40	5817.73	5817.56	34.3	0.005	24	0.013	23.93	7.62	15.93	5821.98	5821.59
SD INLET A-26	SDMH A-25	5818.33	5817.28	52.3	0.02	12	0.01	2.64	7.88	6.55	5819.02	5818.84
SDMH A-25	SD INLET A-20	5816.08	5815.88	39	0.005	24	0.013	32.63	10.39	16.2	5818.84	5818.03

AdventHealth Parker Expansion

Appendix D Maps

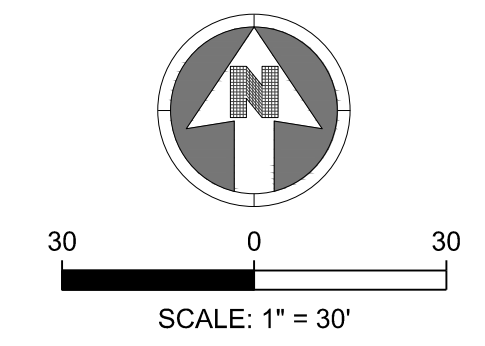
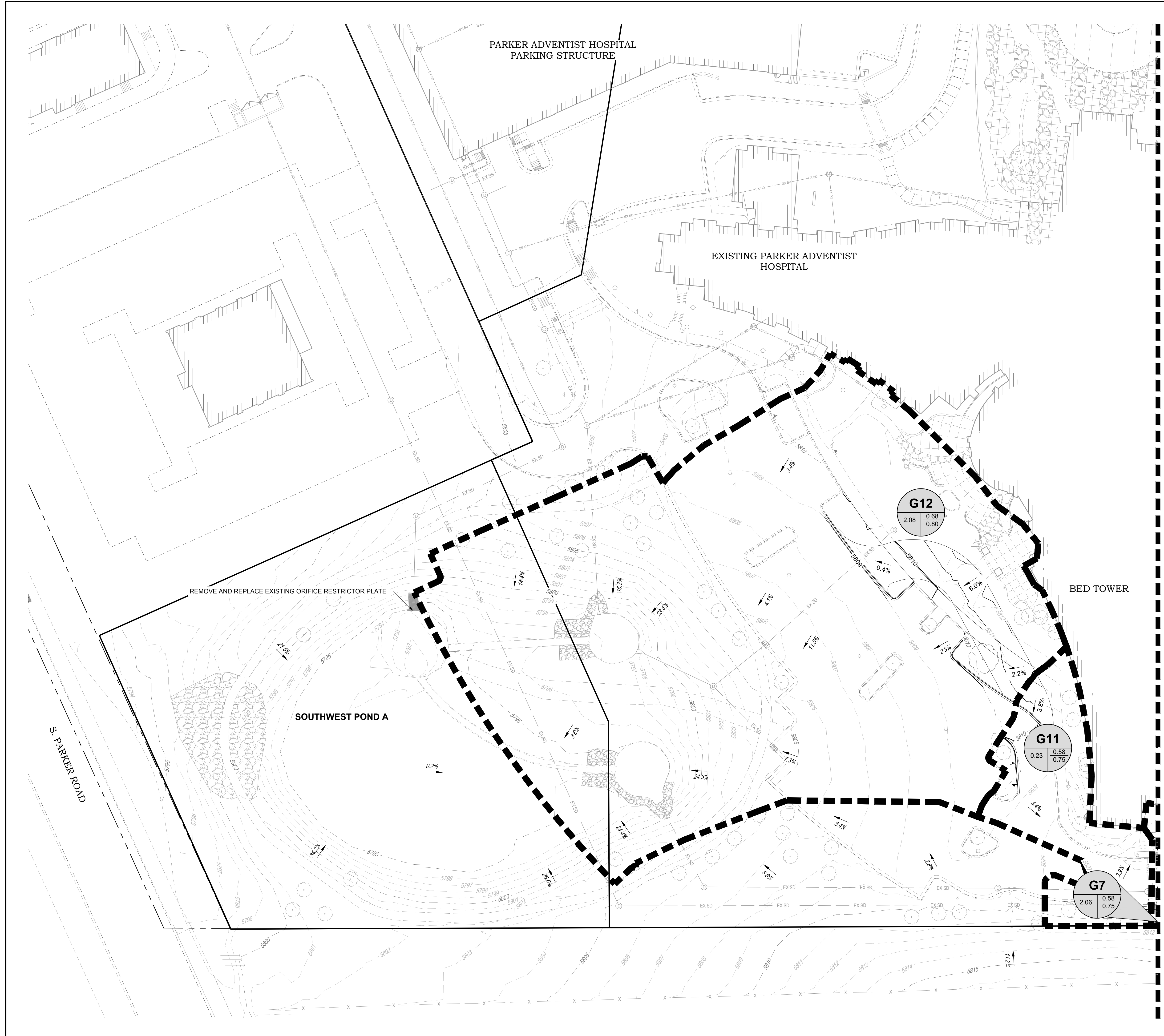

- LEGEND:**
- EXISTING MINOR CONTOURS
 - EXISTING MAJOR CONTOUR
 - PROPOSED MINOR CONTOURS
 - PROPOSED MAJOR CONTOURS
 - PROPOSED STORM SEWER
 - EXISTING STORM SEWER
 - BASIN BOUNDARY
 - PROPOSED MANHOLE
 - PROPOSED INLETS
 - FLOW DIRECTION ARROW
 - DESIGN POINT DESIGNATION
 - BASIN DESIGNATION
 - 5 YEAR COMPOSITE C
 - 100 YEAR COMPOSITE C
 - BASIN AREA (ACRES)

SEE SHEET FIG. 1.2

THE TOWN OF PARKER REVIEW CONSTITUTES GENERAL COMPLIANCE WITH TOWN'S STANDARDS AND APPROVED VARIANCES, SUBJECT TO THESE PLANS BEING STAMPED, SIGNED, AND DATED BY THE PROFESSIONAL ENGINEER OF RECORD. REVIEW BY THE TOWN DOES NOT CONSTITUTE APPROVAL OF THE PLAN DESIGN OR ACCURACY AND CORRECTNESS OF ENGINEERING CALCULATIONS. ERRORS IN THE DESIGN OR CALCULATIONS REMAIN THE RESPONSIBILITY OF THE REGISTERED PROFESSIONAL ENGINEER WHOSE STAMP AND SIGNATURE ARE AFFIXED TO THIS DOCUMENT.

THIS REVIEW DOES NOT CONSTITUTE APPROVAL OF ANY PRIVATE ON-SITE IMPROVEMENTS WHICH MAY BE SHOWN. CONSTRUCTION CANNOT COMMENCE UNTIL ALL REQUIRED DRAINAGE/TRAFFIC REPORT(S), FINAL DEVELOPMENT PLAN(S), SPECIAL REVIEW(S), GRADING PERMIT, AND/OR OTHER PERMITS ARE COMPLETE, APPROVED AND ON FILE WITH THE TOWN OF PARKER

DATE	5/31/2024
DESCRIPTION	1ST SITE PLAN
NO.	1

PROJECT: **ADVENT HEALTH PARKER EXPANSION
 PARKER, CO 80138**

DRAWING TITLE: **PROPOSED DRAINAGE PLAN - WEST**

FILE PATH: C:\Users\ghDCACC\Documents\S.A. Miro, Inc.\Civil\Jobs\23079 AHP Expansion\05 CAD\Plans and Details\Fig. 1.1 - 5/31/2024

THIS DOCUMENT IS SUBJECT TO CHANGE AS A RESULT OF JURISDICTIONAL APPROVALS. CONSTRUCTION DOCUMENTS SHALL CONTAIN THE APPROVAL SIGNATURES OF THE REVIEWING ENTITIES. THIS DOCUMENT IS NOT FOR CONSTRUCTION.

DESIGNED BY: RJH
 DRAWN BY: ARD
 CHECKED BY: MHV
 MIRO JOB NO. 23079

DRAWING NUMBER:
FIG.1.1

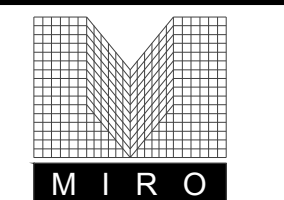

S. A. MIRO, INC.
CIVIL + STRUCTURAL
CONSULTING ENGINEERS

4582 S. Ulster St., Suite 750
Denver, CO 80237
303-741-3737
www.samiro.com



Know what's below.
Call before you dig.

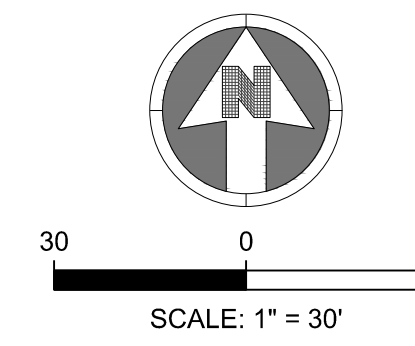

LEGEND:

- - - 43 - - - EXISTING MINOR CONTOURS
 - - - 45 - - - EXISTING MAJOR CONTOUR
 - - - 43 - - - PROPOSED MINOR CONTOURS
 - - - 45 - - - PROPOSED MAJOR CONTOURS
 - — — PROPOSED STORM SEWER
 - — — EX SD — — — EXISTING STORM SEWER
 - — — BASIN BOUNDARY
 - ⊙ PROPOSED MANHOLE
 - PROPOSED INLETS
 - FLOW DIRECTION ARROW
 - △ DESIGN POINT DESIGNATION
-
- B** — BASIN DESIGNATION
- | | |
|------|------|
| 0.52 | 0.73 |
| 0.82 | 0.86 |
- 5 YEAR COMPOSITE C
100 YEAR COMPOSITE C
BASIN AREA (ACRES)

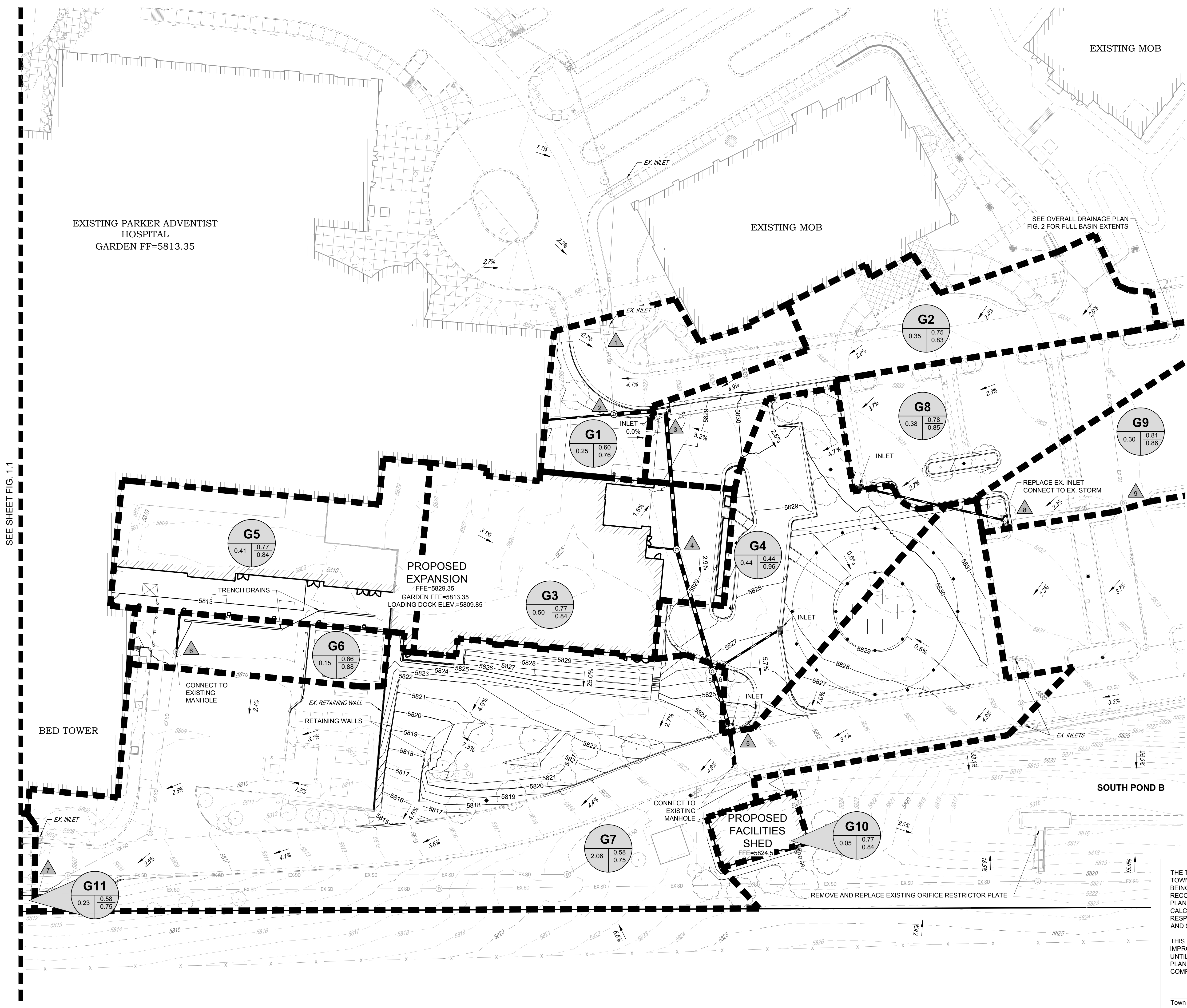

SEE SHEET FIG. 1.1

DATE	DESCRIPTION
5/31/2024	CONSTRUCTION DOCUMENTS

NO.	DESCRIPTION
1	

PROJECT: ADVENTHEALTH PARKER EXPANSION
PARKER, CO 80138

DRAWING TITLE: PROPOSED DRAINAGE PLAN - EAST

FILE PATH: C:\Users\stedi\CVACC\Docsis. A. Miro, Inc.\Civil\Jobs\23079 AHP Expansion\05 CAD\Plans and Details\Fig. 1-Drainage Plan.dwg Fig. 1.2 - 5/31/2024

THE TOWN OF PARKER REVIEW CONSTITUTES GENERAL COMPLIANCE WITH TOWN'S STANDARDS AND APPROVED VARIANCES, SUBJECT TO THESE PLANS BEING STAMPED, SIGNED, AND DATED BY THE PROFESSIONAL ENGINEER OF RECORD. REVIEW BY THE TOWN DOES NOT CONSTITUTE APPROVAL OF THE PLAN DESIGN OR ACCURACY AND CORRECTNESS OF ENGINEERING CALCULATIONS. ERRORS IN THE DESIGN OR CALCULATIONS REMAIN THE RESPONSIBILITY OF THE REGISTERED PROFESSIONAL ENGINEER WHOSE STAMP AND SIGNATURE ARE AFFIXED TO THIS DOCUMENT.

THIS REVIEW DOES NOT CONSTITUTE APPROVAL OF ANY PRIVATE ON-SITE IMPROVEMENTS WHICH MAY BE SHOWN. CONSTRUCTION CANNOT COMMENCE UNTIL ALL REQUIRED DRAINAGE/TRAFFIC REPORT(S), FINAL DEVELOPMENT PLAN(S), SPECIAL REVIEW(S), GRADING PERMIT, AND/OR OTHER PERMITS ARE COMPLETE, APPROVED AND ON FILE WITH THE TOWN OF PARKER

THIS DOCUMENT IS SUBJECT TO CHANGE AS A RESULT OF JURISDICTIONAL APPROVALS. CONSTRUCTION DOCUMENTS SHALL CONTAIN THE APPROVAL SIGNATURES OF THE REVIEWING ENTITIES. THIS DOCUMENT IS NOT FOR CONSTRUCTION.

DESIGNED BY: RJH
DRAWN BY: EDS
CHECKED BY: MHV
MIRO JOB NO. 23079

DRAWING NUMBER:

FIG. 1.2

Town of Parker, Director of Engineering/Public Works Date

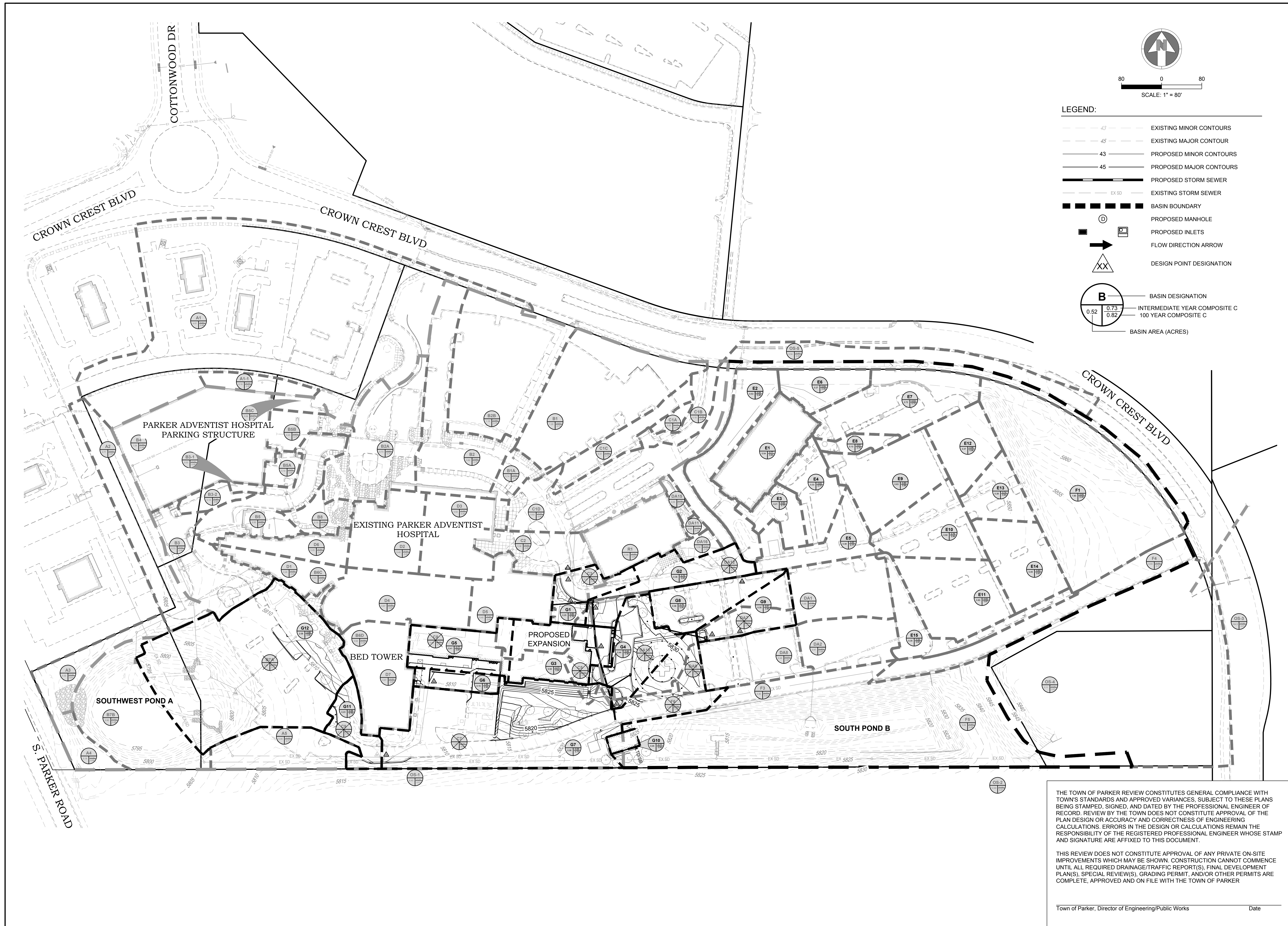

M I R O
S. A. MIRO, INC.
 CIVIL + STRUCTURAL
 CONSULTING ENGINEERS
 4582 S. Ulster St., Suite 750
 Denver, CO 80237
 303-741-3737
 www.samiro.com

811
 Know what's below.
 Call before you dig.

DATE	DESCRIPTION
5/31/2024	CONSTRUCTION DOCUMENTS

PROJECT: **ADVENTHEALTH PARKER EXPANSION
 PARKER, CO 80138**

DRAWING TITLE: **OVERALL DRAINAGE PLAN**

FILE PATH: C:\Users\stetla\Documents\S.A. Miro, Inc.\Civil\Jobs\23079 AHP Expansion\05 CAD\Plans and Details\Fig. 2 - 5/31/2024

THIS DOCUMENT IS SUBJECT TO CHANGE AS A RESULT OF JURISDICTIONAL APPROVALS. CONSTRUCTION DOCUMENTS SHALL CONTAIN THE APPROVAL SIGNATURES OF THE REVIEWING ENTITIES. THIS DOCUMENT IS NOT FOR CONSTRUCTION.

DESIGNED BY: RJH
 DRAWN BY: EDS
 CHECKED BY: MHV
 MIRO JOB NO. 23079

DRAWING NUMBER:
FIG. 2

THE TOWN OF PARKER REVIEW CONSTITUTES GENERAL COMPLIANCE WITH TOWN'S STANDARDS AND APPROVED VARIANCES, SUBJECT TO THESE PLANS BEING STAMPED, SIGNED, AND DATED BY THE PROFESSIONAL ENGINEER OF RECORD. REVIEW BY THE TOWN DOES NOT CONSTITUTE APPROVAL OF THE PLAN DESIGN OR ACCURACY AND CORRECTNESS OF ENGINEERING CALCULATIONS. ERRORS IN THE DESIGN OR CALCULATIONS REMAIN THE RESPONSIBILITY OF THE REGISTERED PROFESSIONAL ENGINEER WHOSE STAMP AND SIGNATURE ARE AFFIXED TO THIS DOCUMENT.

THIS REVIEW DOES NOT CONSTITUTE APPROVAL OF ANY PRIVATE ON-SITE IMPROVEMENTS WHICH MAY BE SHOWN. CONSTRUCTION CANNOT COMMENCE UNTIL ALL REQUIRED DRAINAGE/TRAFFIC REPORT(S), FINAL DEVELOPMENT PLAN(S), SPECIAL REVIEW(S), GRADING PERMIT, AND/OR OTHER PERMITS ARE COMPLETE, APPROVED AND ON FILE WITH THE TOWN OF PARKER

Town of Parker, Director of Engineering/Public Works _____ Date _____

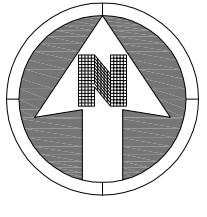
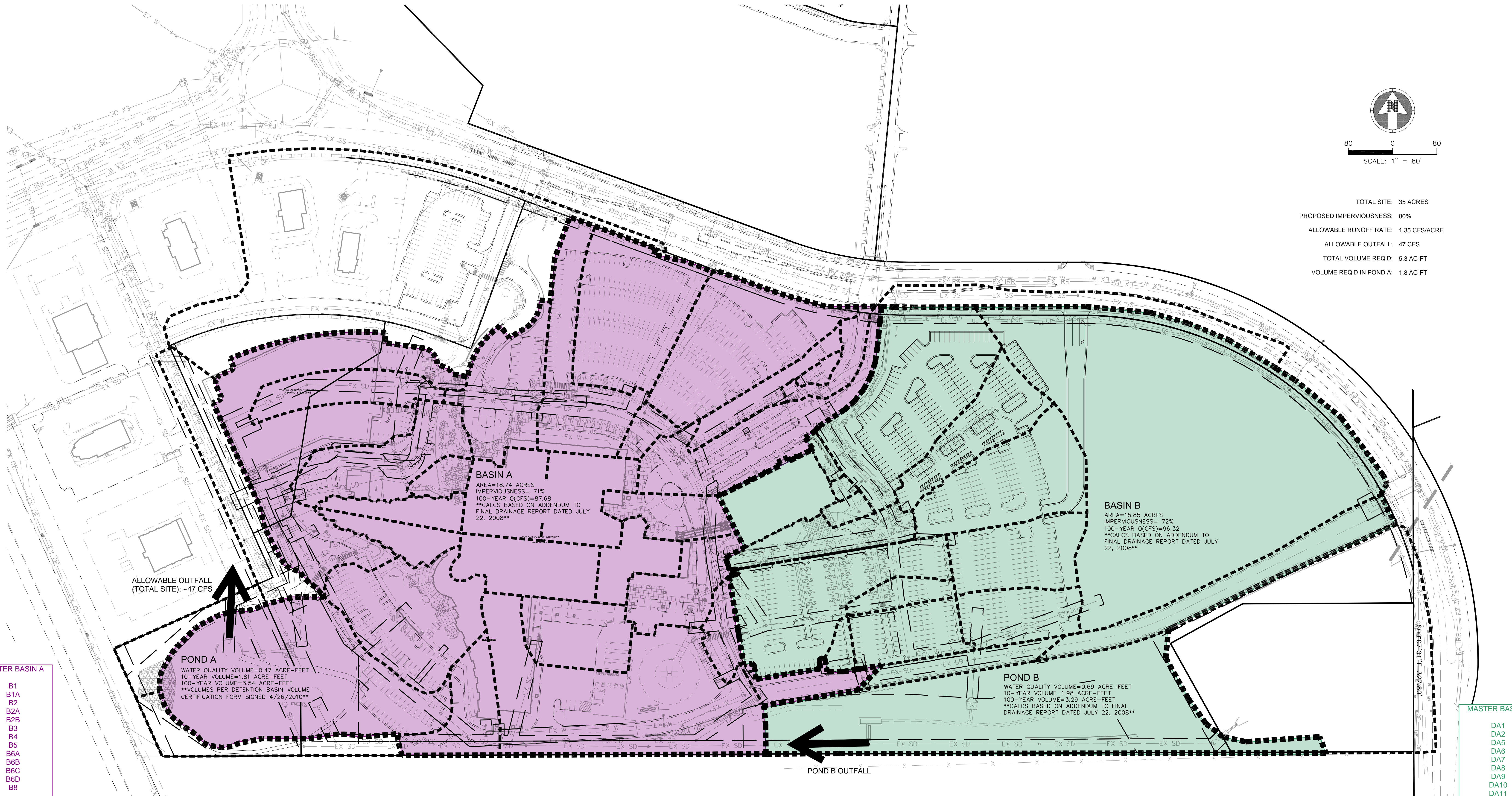

80 0 80
SCALE: 1" = 80'

TOTAL SITE: 35 ACRES
PROPOSED IMPERVIOUSNESS: 80%
ALLOWABLE RUNOFF RATE: 1.35 CFS/ACRE
ALLOWABLE OUTFALL: 47 CFS
TOTAL VOLUME REQ'D: 5.3 AC-FT
VOLUME REQ'D IN POND A: 1.8 AC-FT

BASIN A
AREA=18.74 ACRES
IMPERVIOUSNESS= 71%
100-YEAR Q(CFS)=87.68
CALCS BASED ON ADDENDUM TO FINAL DRAINAGE REPORT DATED JULY 22, 2008

BASIN B
AREA=15.85 ACRES
IMPERVIOUSNESS= 72%
100-YEAR Q(CFS)=96.32
CALCS BASED ON ADDENDUM TO FINAL DRAINAGE REPORT DATED JULY 22, 2008

ALLOWABLE OUTFALL
(TOTAL SITE): ~47 CFS

POND A
WATER QUALITY VOLUME=0.47 ACRE- FEET
10-YEAR VOLUME=1.81 ACRE- FEET
100-YEAR VOLUME=3.54 ACRE- FEET
VOLUMES PER DETENTION BASIN VOLUME CERTIFICATION FORM SIGNED 4/26/2010

POND B
WATER QUALITY VOLUME=0.69 ACRE- FEET
10-YEAR VOLUME=1.98 ACRE- FEET
100-YEAR VOLUME=3.29 ACRE- FEET
CALCS BASED ON ADDENDUM TO FINAL DRAINAGE REPORT DATED JULY 22, 2008

POND B OUTFALL

- MASTER BASIN A
- B1
 - B1A
 - B2
 - B2A
 - B2B
 - B3
 - B4
 - B5
 - B6A
 - B6B
 - B6C
 - B6D
 - B8
 - C1A
 - C1B
 - C1D
 - C2
 - C3
 - C5
 - C7
 - C8
 - C9
 - D1
 - D2
 - D3
 - D4
 - D5
 - D6
 - D7

- MASTER BASIN B
- DA1
 - DA2
 - DA5
 - DA6
 - DA7
 - DA8
 - DA9
 - DA10
 - DA11
 - DA12
 - DA13
 - DA15
 - DA16
 - F1
 - F3
 - F4
 - F5
 - F6
 - R1

**ADDENDUM TO
FINAL DRAINAGE AND
EROSION CONTROL
REPORT**

FOR

**PARKER ADVENTIST
HOSPITAL**

May 1, 2002

Rev. January 24, 2003

Rev. August 31, 2006

Rev. June 17, 2008

Rev. July 22, 2008

PREPARED BY:

S. A. Miro, Inc.

Consulting Engineers

4582 South Ulster St. Pkwy.,
Suite 1501

Denver, Colorado 80237

(303) 741-3737

fax (303) 694-3134

Contact: Steve Mystkowski, P.E.

S. A. Miro Job No. 07135

Previous job No. 01173

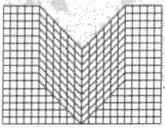

M I R O

S. A. Miro, Inc.

"This Addendum to the Final Drainage and Erosion Control Report for Parker Adventist Hospital was prepared under my direct supervision in accordance with the provisions of the Town of Parker Storm Drainage Design and Environmental Criteria, and was designed to comply with the provisions thereof. I understand that the Town of Parker does not and will not assume liability for drainage facilities designed by others."

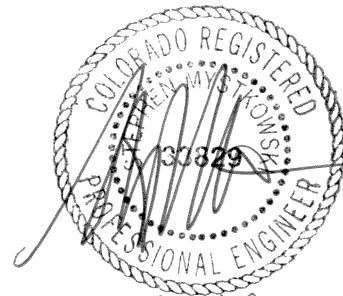

7/22/08

Stephen Mystkowski, P.E.
Registered Professional Engineer State
of Colorado No. 33829

DRAINAGE AND EROSION CONTROL DRAWINGS

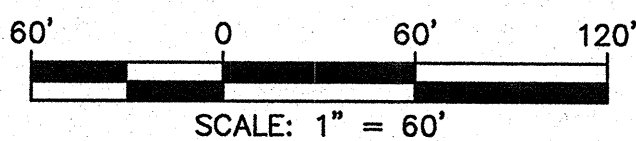

CALL UTILITY NOTIFICATION
CENTER OF COLORADO
1-800-922-1987

CALL 2-BUSINESS DAYS IN ADVANCE BEFORE
YOU DIG, GRADE, OR EXCAVATE FOR THE
MARKING OF UNDERGROUND MEMBER UTILITIES.

BENCHMARK:

THE SITE BENCHMARK IS DOUGLAS COUNTY CONTROL
MONUMENT NO. 1.115026, 473.35'± NORTH AND 1959.02'±
WEST OF THE WEST 1/4 CORNER OF SECTION 3, TOWNSHIP
6 SOUTH, RANGE 66 WEST OF THE 6TH PRINCIPAL
MERIDIAN. 3-1/2" ALUMINUM CAP, ELEVATION 5759.78.

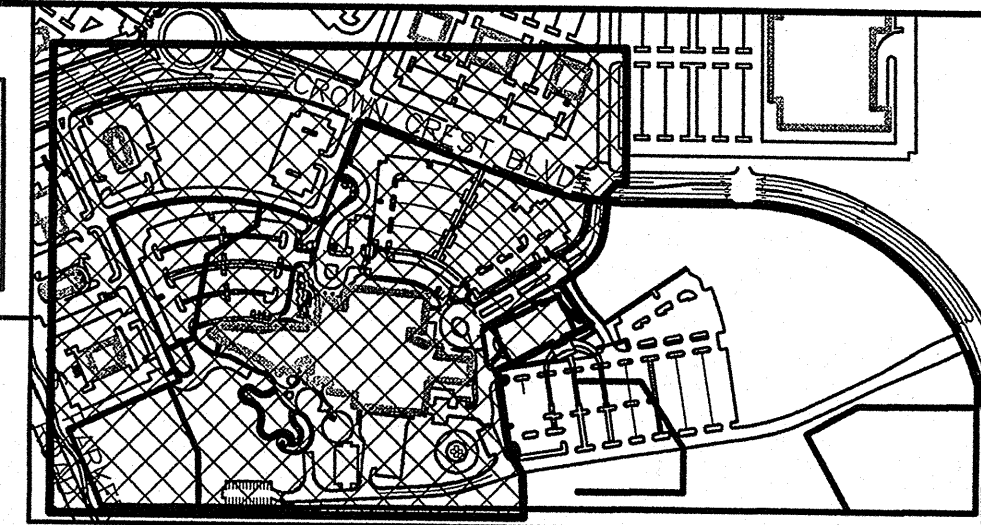

MIRO CONSULTING ENGINEERS
S. A. MIRO, INC.
Consulting Engineers
4582 South Ulster Street Pkwy.
Suite 1501 Denver, CO 80237
ph. 303 741 3737
fax 303 694 3134

LEGEND:

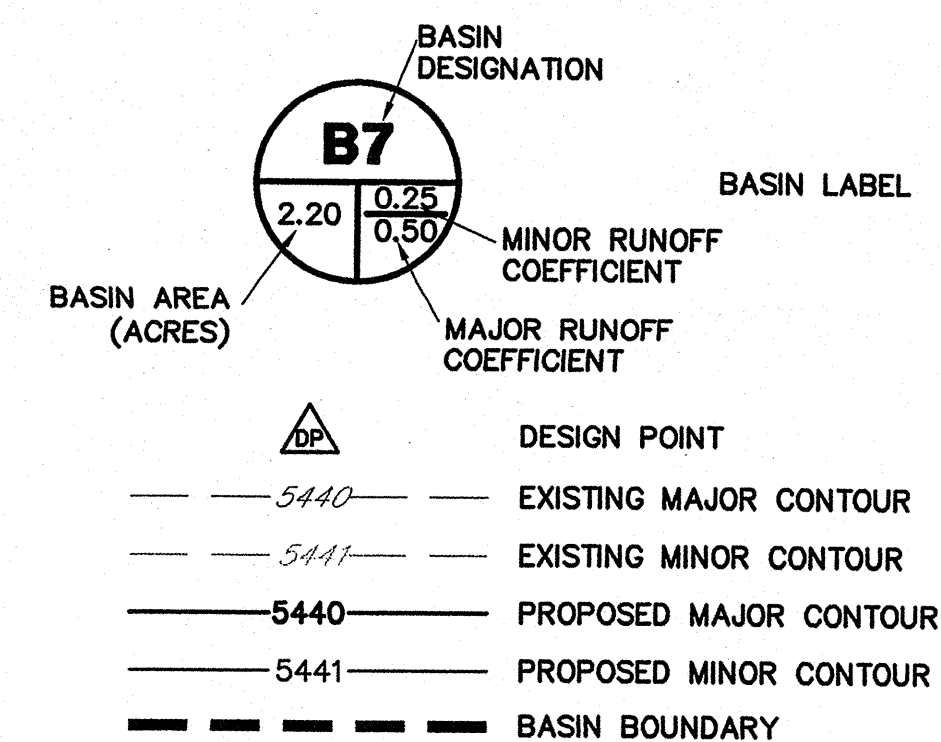

RUNOFF SUMMARY

DESIGN POINT	TRIBUTARY BASINS	DIRECT RUNOFF		TOTAL RUNOFF	
		Q-5 (cfs)	Q-100 (cfs)	Q-5 (cfs)	Q-100 (cfs)
N7	B2B	3.89	7.08	3.89	7.09
N6	B2, B2B	3.11	5.68	5.56	11.97
22	D2	2.03	3.60	2.03	3.60
33	B2, B2B, D2	-	-	6.93	14.90
6	B2, B2A, B2B, D2	2.47	4.68	8.65	18.82
8	B4	2.31	3.90	2.31	3.90
34	B2, B2A, B2A, B4, D2	-	-	10.00	21.62
45	B8	0.13	0.52	0.13	0.52
46	D6	1.06	1.88	1.06	1.88
47	B8, D6	-	-	0.79	1.95
9	B5, B8, B6	1.82	3.51	2.21	5.25
35	B5, B8, B6	-	-	11.09	26.49
7	B3	5.22	9.97	5.22	9.97
36	B2, B2A, B2B, B3, B4, B5, B8, D2, D6	-	-	15.79	35.43
21	D1	1.08	1.91	1.08	1.91
38	B2, B2A, B2B, B3, B4, B5, B8, D1, D2, D6	-	-	16.38	36.71
N3	C1A	0.10	0.26	0.10	0.26
N4	C1A, C1B	0.35	0.89	0.37	1.13
N8	B1	3.40	6.40	3.40	6.40
N2	B1, B1A	0.44	0.84	3.20	7.11
N5	B1, B1A, C1A, C1B, C1C	1.21	2.17	4.27	9.70
23	D3	2.18	3.87	2.18	3.87
12	B1, B1A, C1A, C1B, C1C, C1D, D3	3.81	6.79	8.25	18.09
13	B1, B1A, C1A, C1B, C1C, C1D, C2, D3	1.53	2.68	9.19	20.08
24	D5	1.30	2.30	1.30	2.30
39	B1, B1A, C1A, C1B, C1C, C1D, C2, D3, D5	-	-	9.96	21.77
14	C3	1.28	2.77	1.28	2.77
15	B1, B1A, C1A, C1B, C1C, C1D, C3, D3, D5,	-	-	10.73	23.81

CLIENT NAME: **PARKER ADVENTIST HOSPITAL**
PROJECT NAME: **PARKER HOSPITAL ONSITE PARKING AND INFRASTRUCTURE PARKER, CO**

REV.	DESCRIPTION	DATE
12		
11		
10		
9		
8		
7		
6		
5		
4	TOWN OF PARKER MYLAR SUBMITTAL	07/22/2008
3	TOWN OF PARKER 3RD SUBMITTAL	06/17/2008
2	TOWN OF PARKER 2ND SUBMITTAL	05/19/2008
1	TOWN OF PARKER 1ST SUBMITTAL	03/17/2008

FOR AND ON BEHALF OF S.A. MIRO, INC.

07/22/2008

DESIGNED BY: LUM
DRAWN BY: LUM
CHECKED BY: JPZ

MIRO PROJECT NO: 07-133
CLIENT PROJECT NO: .

DATE: 03/17/2008

DRAWING SCALE: 1" = N/A VER. 1" = 30' HOR.
DRAWING TITLE: **DRAINAGE PLAN**

DRAWING NUMBER: **C220**

J:\Web\07133_P41_M02B\06_CAD\Plans and Details\Drainage\C220-DRAINAGE-PLAN.dwg C220.jrz 7.22.2008 11:24:54 AM

60' 0 60' 120'
SCALE: 1" = 60'

CALL UTILITY NOTIFICATION
CENTER OF COLORADO
1-800-922-1987
CALL 2-BUSINESS DAYS IN ADVANCE BEFORE
YOU DIG, GRADE, OR EXCAVATE FOR THE
MARKING OF UNDERGROUND MEMBER UTILITIES.

BENCHMARK:
THE SITE BENCHMARK IS DOUGLAS COUNTY CONTROL
MONUMENT NO. 1.115026, 473.35'± NORTH AND 1959.02'±
WEST OF THE WEST 1/4 CORNER OF SECTION 3, TOWNSHIP
6 SOUTH, RANGE 66 WEST OF THE 6TH PRINCIPAL
MERIDIAN. 3-1/2" ALUMINUM CAP, ELEVATION 5759.78.

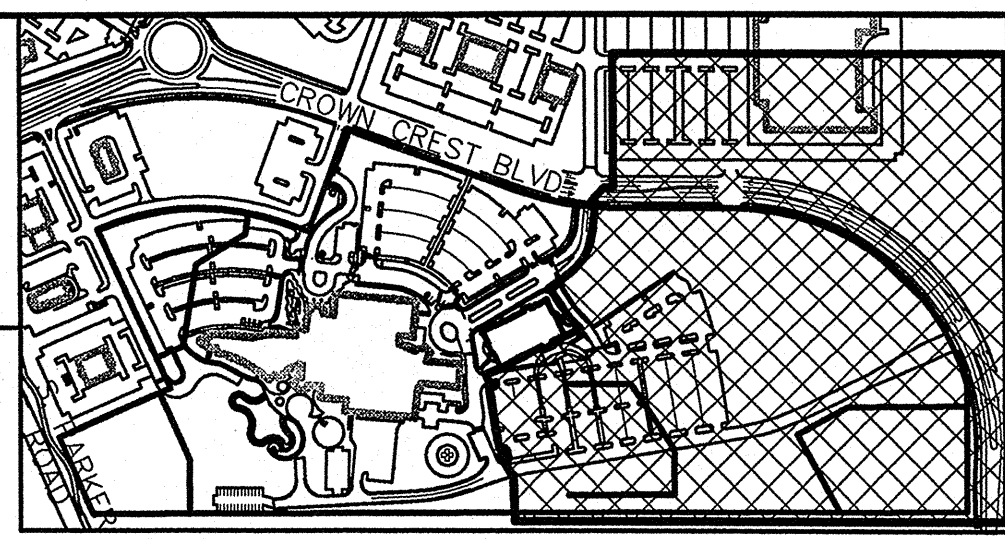

CONSULTING ENGINEERS
M.I.R.O.
S. A. MIRO, INC.
Consulting Engineers
4582 South Ulster Street Pkwy.
Suite 1501 Denver, CO 80237
ph. 303 741 3737
fax 303 694 3134

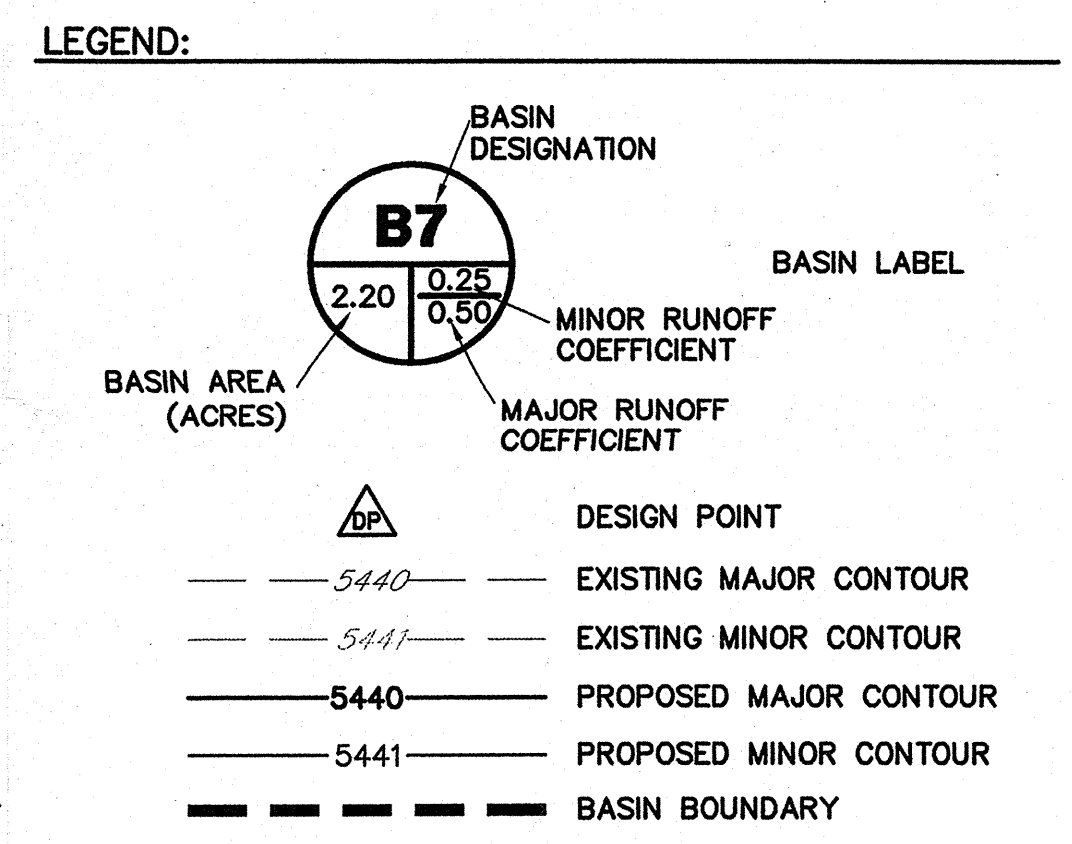

PARKER ADVENTIST HOSPITAL
PARKER HOSPITAL
ONSITE PARKING AND INFRASTRUCTURE
PARKER, CO

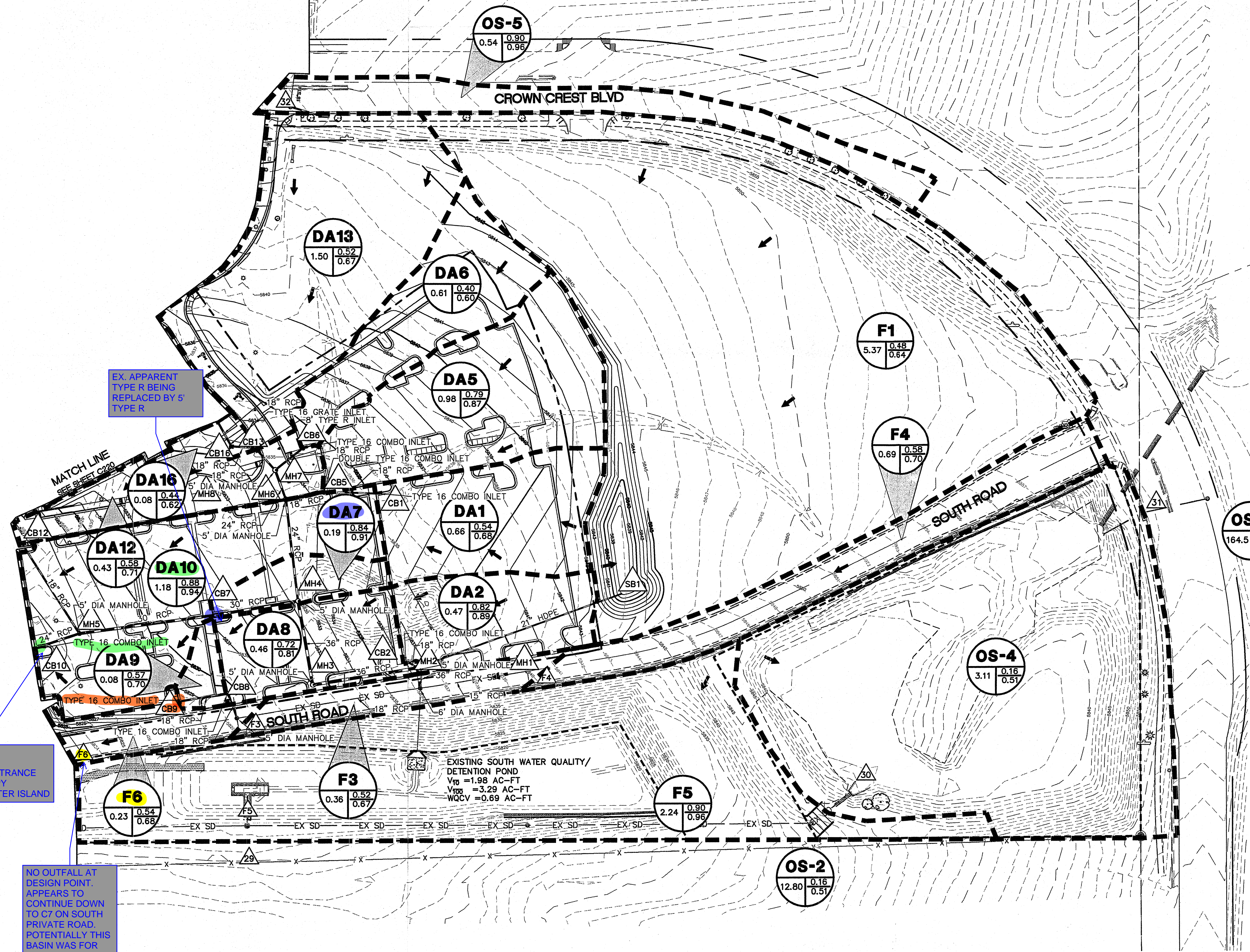

RUNOFF SUMMARY

DESIGN POINT	TRIBUTARY BASINS	DIRECT RUNOFF		TOTAL RUNOFF	
		Q-5 (cfs)	Q-100 (cfs)	Q-5 (cfs)	Q-100 (cfs)
16	B1, B1A, C1A, C1B, C1C, C1D, C3, C5, D3, D5	0.49	1.17	10.98	24.60
19	CB	1.93	3.54	1.93	3.54
40	B1, B1A, C1A, C1B, C1B, C1D, C3, C5, C8, D3, D5	-	-	11.90	26.72
18	C7, C9	3.08	10.13	3.08	10.13
28	OS-1	3.94	19.40	3.94	19.40
20	B1, B1A, C1A, C1B, C1C, C1D, C3, C5, C7, C8, C9, D3, D5, OS-1	-	-	17.07	52.36
CB1	DA1	1.64	3.28	1.64	3.28
CB5	DA1, DA5	4.31	7.44	4.37	9.36
CB15	DA15	0.05	0.18	0.05	0.18
CB11	DA15, DA11	0.02	0.11	0.06	0.29
RC1	R1	1.84	3.35	1.84	3.35
CB16	DA11, DA15, DA16, R1	0.17	0.39	1.45	3.34
CB13	DA11, DA13, DA15, DA16, R1	3.40	6.93	4.26	10.16
CB6	DA6	0.97	2.34	0.97	2.34
MH7	DA6, DA11, DA13, DA15, DA16, R1	-	-	4.86	11.90
MH6	DA1, DA5, DA6, DA11, DA13, DA15, DA16, R1	-	-	8.68	20.11
CB12	DA12	1.40	2.71	1.40	2.71
CB10	DA10	5.79	9.74	5.79	9.74
MH5	DA10, DA12	-	-	5.90	12.13
CB7	DA7, DA10, DA12	0.89	1.52	6.45	13.30
MH4	DA1, DA5, DA6, DA7, DA10, DA11, DA12, DA13, DA15, DA16, R1	-	-	13.50	30.03
MH3	DA1, DA5, DA6, DA7, DA10, DA11, DA12, DA13, DA15, DA16, R1	-	-	13.37	29.79
SB1	F1	12.56	27.03	12.56	27.03
CB2	DA2	2.14	3.70	2.14	3.70
MH2	DA2, DA2, DA5, DA6, DA7, DA10, DA11, DA12, DA13, DA15, DA16, F1, R1	-	-	14.79	32.65
CB9	DA9	0.25	0.50	0.25	0.50
CB8	DA8, DA9	1.94	3.47	1.73	3.89

CLIENT NAME: PARKER ADVENTIST HOSPITAL
PROJECT NAME: PARKER HOSPITAL ONSITE PARKING AND INFRASTRUCTURE PARKER, CO

REV	DESCRIPTION	DATE
12		
11		
10		
9		
8		
7		
6		
5		
4	TOWN OF PARKER MYLAR SUBMITTAL	07/22/2008
3	TOWN OF PARKER 3RD SUBMITTAL	05/17/2008
2	TOWN OF PARKER 2ND SUBMITTAL	05/19/2008
1	TOWN OF PARKER 1ST SUBMITTAL	03/17/2008

FOR AND ON BEHALF OF S.A. MIRO, INC.

DESIGNED BY: LUM
DRAWN BY: LUM
CHECKED BY: JPZ
MIRO PROJECT NO: 07-133
CLIENT PROJECT NO: .
DATE: 03/17/2008
DRAWING SCALE: 1" = N/A VER. 1" = 30' HOR.
DRAWING TITLE: DRAINAGE PLAN

DRAWING NUMBER: **C221**

BEING DEMO'D
NEAR MAIN ENTRANCE UNDER CANOPY WEST OF CENTER ISLAND

NO OUTFALL AT DESIGN POINT. APPEARS TO CONTINUE DOWN TO C7 ON SOUTH PRIVATE ROAD. POTENTIALLY THIS BASIN WAS FOR DRAINAGE PAN SIZING

J:\Jobs\07133 PAH MOB2\05 CAD\Plans and Details\IMAGE-PLAN.dwg C221 Plr 7.22.2008 11:25:10 AM



SOUTH POND
 WOCV=0.75 AC-FT
 10-YR VOLUME=1.40 AC-FT
 10-YR Q REL=21 CFS
 10-YR WSEL=5819.26
 100-YR VOLUME=3.01 AC-FT
 100-YR Q REL=33 CFS
 100-YR WSEL=5820.92

LEGEND:

- 43 --- EXIST. INTERMEDIATE CONTOURS
- 45 --- EXIST. INDEX CONTOURS
- 43 --- PROPOSED INTERMEDIATE CONTOURS
- 45 --- PROPOSED INDEX CONTOURS
- BASIN BOUNDARY
- SUB-BASIN BOUNDARY
- FLOW ARROW
- △ X DESIGN POINT DESIGNATION / INTERMEDIATE YEAR FLOW / 100 YEAR FLOW
- X BASIN DESIGNATION
- X.XX / X INTERMEDIATE YEAR COMPOSITE C / 100 YEAR COMPOSITE C
- LOT LINE
- PROPOSED STORM SEWER
- EXISTING STORM SEWER

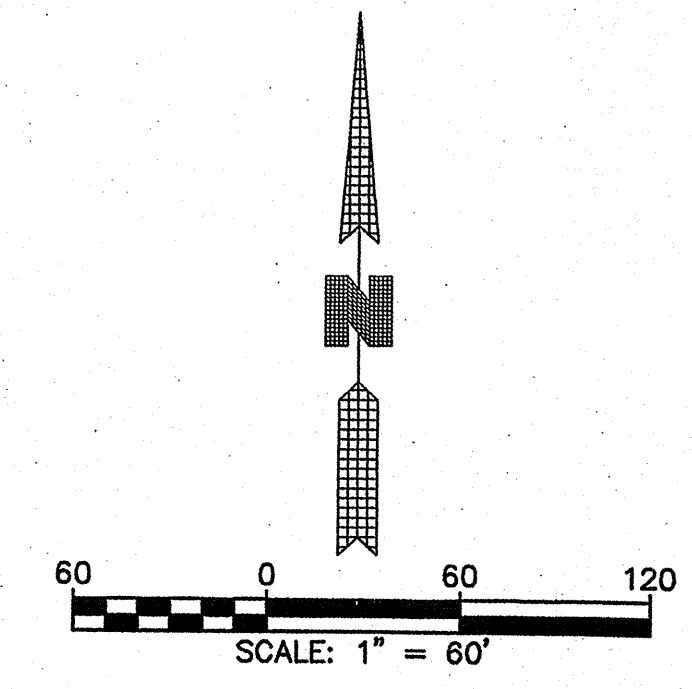

RUNOFF SUMMARY				RUNOFF SUMMARY			
BASIN	TRIBUTARY AREA (ac.)	DIRECT Q-5 (cfs)	RUNOFF Q-100 (cfs)	BASIN	TRIBUTARY AREA (ac.)	DIRECT Q-5 (cfs)	RUNOFF Q-100 (cfs)
A1	4.55	10.38	23.52	C6	1.46	2.43	7.35
A2	0.72	1.66	4.08	C7	2.00	2.41	8.34
A3	0.32	0.22	1.36	C8	0.53	1.78	3.90
A4	0.42	0.21	1.25	C9	0.45	0.80	2.33
B1	1.17	3.59	8.22	D1	0.25	1.06	2.06
B2	2.38	5.86	13.79	D2	0.49	2.04	3.96
B3	1.87	5.54	11.93	D3	0.53	2.19	4.26
B4	0.46	2.00	3.88	D4	0.58	2.40	4.66
B5	0.65	1.89	3.76	D5	0.31	1.30	2.53
B6	1.09	2.69	6.84	D6	0.25	1.06	2.06
B7	2.20	4.93	12.00	E1	5.73	24.72	65.77
B8	0.20	0.15	0.74	E2	7.86	33.88	47.98
C1	1.72	4.83	12.21	OS-1	6.40	3.07	18.56
C2	0.60	1.64	3.96	OS-2	12.80	5.76	35.20
C3	0.86	2.18	5.30	OS-3	164.50	44.41	271.42
C4	0.78	2.31	5.18	OS-4	3.11	1.73	10.26
C5	0.83	3.11	6.34	OS-5	0.54	2.32	4.51

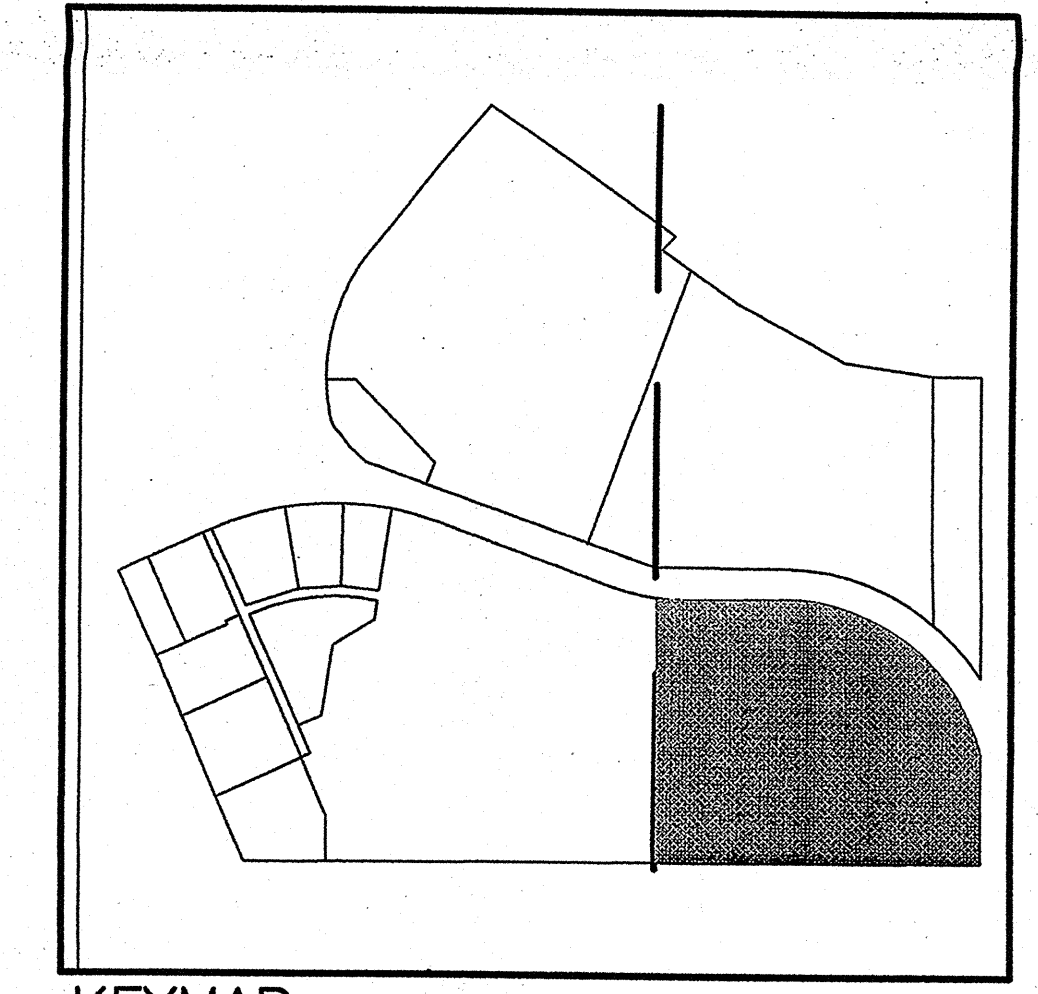

KEYMAP NOT TO SCALE

CALL UTILITY NOTIFICATION
 CENTER OF COLORADO
1-800-922-1987
 CALL 2-BUSINESS DAYS IN ADVANCE
 BEFORE YOU DIG, GRADE, OR EXCAVATE
 FOR THE MARKING OF UNDERGROUND
 MEMBER UTILITIES.

S.A. MIRO, INC.
CONSULTING ENGINEERS
 4582 S. ULSTER ST. PKWY. SUITE 1501 DENVER, COLORADO 80237 (303) 741-3737

NO.	DATE	NAME
1	5/01/02	DEN

PARKER ADVENTIST HOSPITAL

DRAINAGE PLAN - EAST

DATE: 2/25/02	DRAWN BY: JJC	SCALE: 1" = 60'	SHEET NO. C2.22	JOB NO. 01173
DESIGNED BY: SLG	CHECKED BY: KDB			



SOUTHWEST POND
 WQCV=0.80 AC-FT
 10-YR VOLUME=1.70 AC-FT
 10-YR Q REL=25 CFS
 10-YR WSEL=5797.50
 100-YR VOLUME=4.00 AC-FT
 100-YR Q REL=33 CFS
 100-YR WSEL=5799.73
 MICROPPOOL

SEE BED TOWER ADDITION DRAINAGE
 CONFORMANCE LETTER EXCERPTS
 FOR FLOW RATES AT THESE TWO (19
 & 25) DESIGN POINTS

LEGEND:

- 43 --- EXIST. INTERMEDIATE CONTOURS
- 45 --- EXIST. INDEX CONTOURS
- 43 --- PROPOSED INTERMEDIATE CONTOURS
- 45 --- PROPOSED INDEX CONTOURS
- BASIN BOUNDARY
- SUB-BASIN BOUNDARY
- FLOW ARROW
- △ X --- DESIGN POINT DESIGNATION/
INTERMEDIATE YEAR FLOW/100 YEAR FLOW
- X --- BASIN DESIGNATION
- X.XX --- BASIN AREA (ACRES) / INTERMEDIATE YEAR COMPOSITE C
100 YEAR COMPOSITE C
- LOT LINE
- PROPOSED STORM SEWER
- EXISTING STORM SEWER

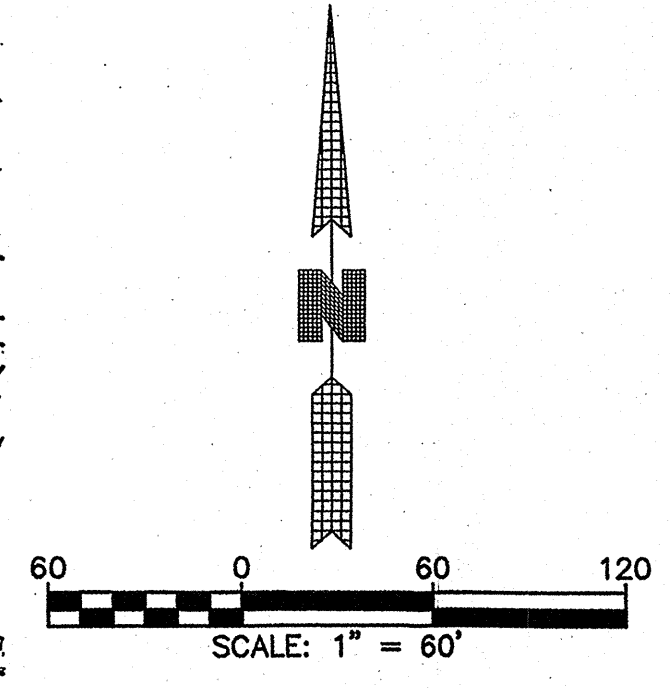

RUNOFF SUMMARY				RUNOFF SUMMARY			
BASIN	TRIBUTARY AREA (ac.)	DIRECT RUNOFF		BASIN	TRIBUTARY AREA (ac.)	DIRECT RUNOFF	
		Q-5 (cfs)	Q-100 (cfs)			Q-5 (cfs)	Q-100 (cfs)
A1	4.55	10.38	23.52	C6	1.46	2.43	7.35
A2	0.72	1.66	4.08	C7	2.00	2.41	8.34
A3	0.32	0.22	1.36	C8	0.53	1.78	3.90
A4	0.42	0.21	1.25	C9	0.45	0.80	2.33
B1	1.17	3.59	8.22	D1	0.25	1.06	2.06
B2	2.38	5.86	13.79	D2	0.49	2.04	3.96
B3	1.87	5.54	11.93	D3	0.53	2.19	4.26
B4	0.46	2.00	3.88	D4	0.66	2.40	4.66
B5	0.65	1.89	3.76	D5	0.31	1.30	2.53
B6	1.99	2.69	6.84	D6	0.25	1.06	2.06
B7	2.20	4.93	12.00	E1	5.73	24.72	47.98
B8	0.20	0.15	0.74	E2	7.86	33.88	65.77
C1	1.72	4.83	12.21	OS-1	6.40	3.07	18.58
C2	0.60	1.64	3.96	OS-2	12.80	5.76	35.20
C3	0.86	2.18	5.30	OS-3	164.50	44.41	271.42
C4	0.78	2.31	5.78	OS-4	3.11	1.73	10.26
C5	0.83	3.11	6.34	OS-5	0.54	2.32	4.51

USING UPDATED FLOW RATES FROM BED TOWER ADDITION DRAINAGE LETTER IN LIEU OF SMALLER TRIBUTARY AREA SHOWN HERE

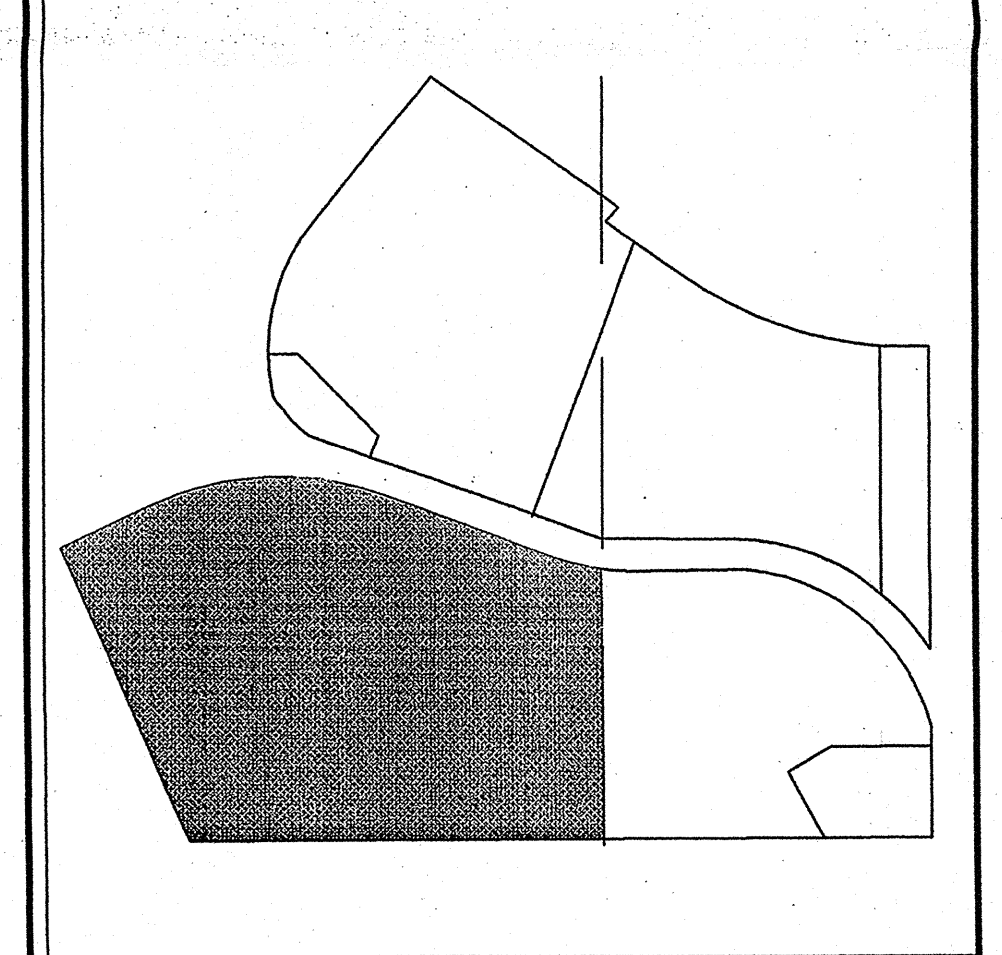

KEYMAP
 NOT TO SCALE

CALL UTILITY NOTIFICATION
 CENTER OF COLORADO
1-800-922-1987
 CALL 2-BUSINESS DAYS IN ADVANCE
 BEFORE YOU DIG, GRADE, OR EXCAVATE
 FOR THE MARKING OF UNDERGROUND
 MEMBER UTILITIES.

S.A. MIRO, INC.
CONSULTING ENGINEERS
 4582 S. ULSTER ST. PKWY. SUITE 1501 DENVER, COLORADO 80237 (303) 741-3737

NO.	DATE	NAME
1	5/01/02	DEN

PARKER ADVENTIST HOSPITAL

DRAINAGE PLAN - WEST

DATE:	DRAWN BY:	SCALE:	SHEET NO.	JOB NO.
2/25/02	JIC	1" = 60'	C2.21	01173
DESIGNED BY:	CHECKED BY:			
SLG	KDB			

LEGEND:

- 43--- EXIST. INTERMEDIATE CONTOURS
- 45--- EXIST. INDEX CONTOURS
- 45--- PROPOSED INTERMEDIATE CONTOURS
- 45--- PROPOSED INDEX CONTOURS
- EXISTING SUB-BASIN BOUNDARY
- PROPOSED SUB-BASIN BOUNDARY
- ← FLOW ARROW
- △ DESIGN POINT DESIGNATION
- BASIN DESIGNATION
- BASIN AREA (ACRES)
- C_s/C₁₀₀ RUNOFF COEF
- LOT LINE
- PROPOSED STORM SEWER
- EXISTING STORM SEWER

CALL UTILITY NOTIFICATION
CENTER OF COLORADO
1-800-922-1987
CALL 2-BUSINESS DAYS IN ADVANCE
BEFORE YOU DIG, GRADE, OR EXCAVATE
FOR THE MARKING OF UNDERGROUND
MEMBER UTILITIES.

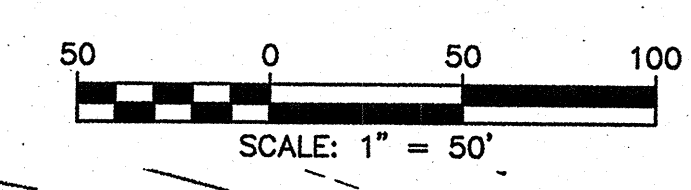
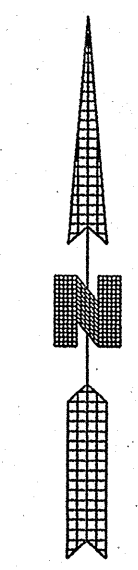

RUNOFF SUMMARY				RUNOFF SUMMARY			
BASIN	TRIBUTARY AREA (ac.)	DIRECT Q-5 (cfs)	Q-100 (cfs)	BASIN	TRIBUTARY AREA (ac.)	DIRECT Q-5 (cfs)	Q-100 (cfs)
A1	4.55	10.38	23.52	D1	0.25	1.08	2.06
A2	0.72	1.66	4.08	D2	0.49	2.04	3.96
A3	0.32	0.22	1.36	D3	0.53	2.19	4.26
A4	0.42	0.21	1.25	D4	0.58	2.40	4.66
B1	1.17	3.59	8.22	D5	0.31	1.30	2.53
B2	2.38	5.86	13.79	D6	0.25	1.06	2.06
B3	1.87	5.54	11.93	F1	10.07	25.32	59.40
B4	0.46	2.00	3.88	F2	2.95	6.34	14.97
B5	0.65	1.89	3.76	F3	0.31	1.11	2.39
B6	1.09	2.69	6.84	F4	0.71	2.24	5.09
B7	2.20	4.93	12.00	F5	2.77	1.38	8.61
B8	0.20	0.15	0.74	F6	0.21	0.71	1.57
C1	1.72	4.83	12.21	OS-1	6.40	3.07	18.56
C2	0.29	1.11	2.31	OS-2	12.80	5.76	35.20
C3	0.41	1.37	3.06	OS-3	164.50	44.41	271.42
C5	0.10	0.44	0.88	OS-4	3.11	1.73	10.26
C7	2.00	2.41	8.34	OS-5	0.54	2.32	4.51
C8	0.53	1.78	3.90				
C8	0.45	0.80	2.33				

SOUTH POND

10-YR PEAK INFLOW (CFS)	65.0
10-YR PEAK OUTFLOW (CFS)	19.0
100-YR PEAK INFLOW (CFS)	118.0
100-YR PEAK OUTFLOW (CFS)	31.0
WATER QUALITY CAPTURE VOLUME (AC-FT)	0.67
WQCV WSEL (FT)	5817.75
10-YEAR REQUIRED VOLUME (AC-FT)	1.87
10-YEAR WSEL (FT)	5819.39
100-YEAR REQUIRED VOLUME (AC-FT)	3.37
100-YEAR WSEL (FT)	5820.98
DETENTION POND CAPACITY (AC-FT)	3.37
AVAILABLE FREEBOARD (FT)	1.0

CONCEPTUAL SITE SHOWN FOR CALCULATION PURPOSES ONLY

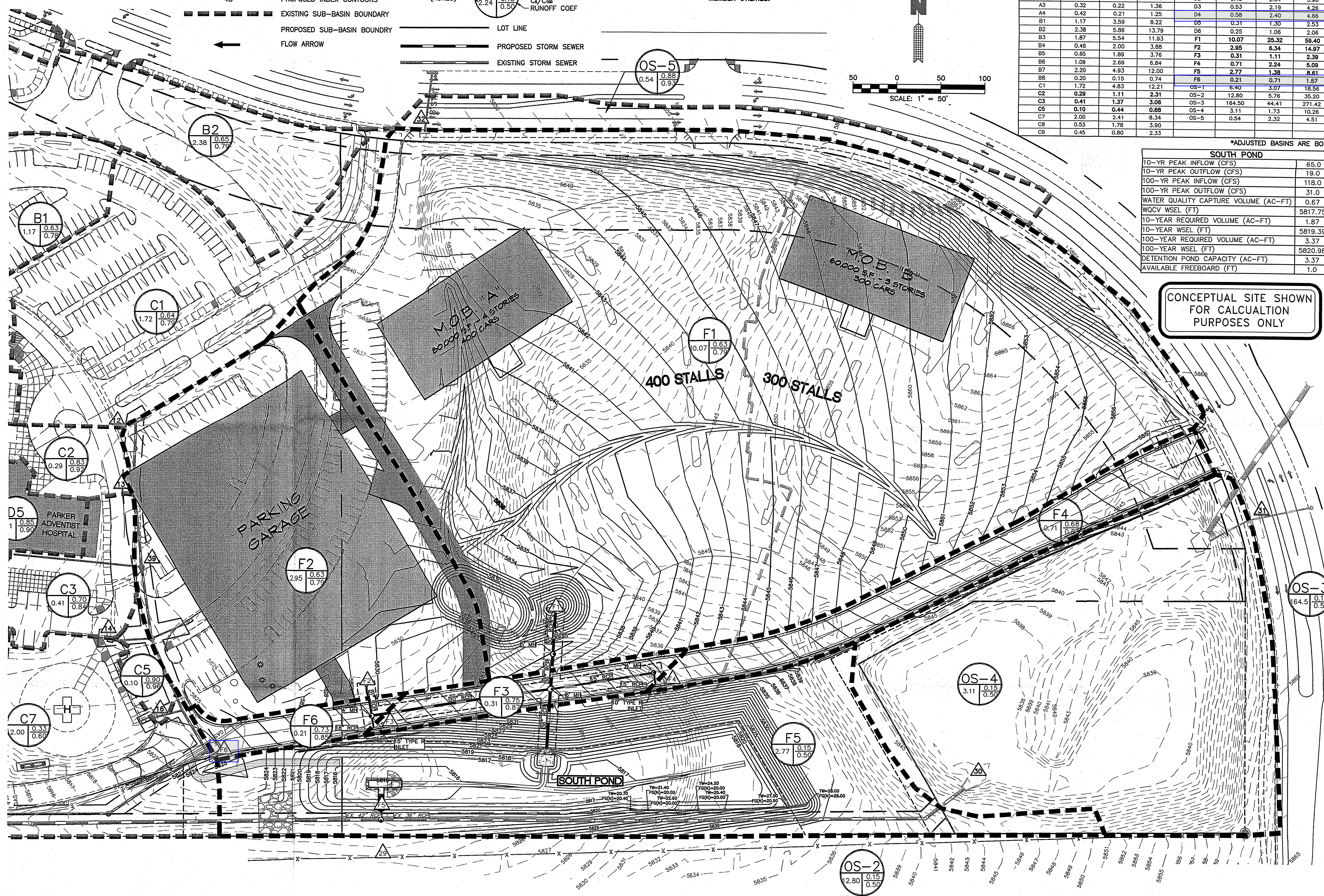

DEE WATER POINT COMPANY
M.I.R.O. S.A. MIRO INC. CONSULTING ENGINEERS
3500 JFK PARKWAY, SUITE 310
FORT COLLINS, CO 80525
(970) 266-1900
(970) 266-0278 FAX
WWW.SAMIRO.COM

REV.	DESCRIPTION	DATE

CLIENT NAME: PARKER ADVENTIST HOSPITAL
PROJECT NAME: MOB CAMPUS SITE WORK PLANS
DRAWING TITLE: MASTER DRAINAGE

DESIGNED BY: JTC
DRAWN BY: JTC
CHECKED BY: BEC
FILE NAME:
DATE: 08/29/06

MIRO JOB NUMBER: 06047
CLIENT JOB NUMBER: N/A

C2.20



Denver
Summit County
Abu Dhabi

Civil
Structural
Integrated Services

January 06, 2010

Tom Williams
Town of Parker
Engineering Development Review
20120 East Main Street
Parker, CO 80138

RE: Parker Adventist Hospital–Bed Tower Addition

Mr. Williams,

This letter serves as an addendum to the approved Final Drainage and Erosion Control Report for the Parker Adventist Hospital. The purpose of this letter is to demonstrate the existing/designed storm sewer facilities serving the improvements for the Parker Adventist Hospital Bed Tower Project are capable of conveying the runoff generated by the proposed improvements. The previous update to the report was for Parking Lot M dated May 29, 2009.

All tributary drainage from the Bed Tower expansion is routed through proposed and existing storm sewer facilities to the Southwest Detention/Water Quality Pond.

I. DESCRIPTION OF CHANGES

Modifications to the Final Drainage and Erosion Control Report are as follows:

- Re-delineate and recalculate pervious and impervious areas for previously established sub-basins B6A, B6B, B6C, B6D, C7, C8, C9, D4, and D7 to correspond with slight land use updates related to the Bed Tower.
- The design of approximately 276 LF of storm sewer system to replace the existing storm sewer located underneath the proposed Bed Tower's footprint.
- The design of inlets and storm sewer facilities for the Bed Tower's healing garden connected to the storm sewer system associated with the Lot M improvements.

The calculations within this report follow the design criteria set forth in the original drainage report, the Town of Parker Storm Drainage and Environmental Criteria Manual, and the Urban Storm Drainage Criteria Manual. Descriptions of the basin calculations are found within the following sections.

II. DRAINAGE DESIGN CRITERIA

Regulations

This Final Drainage Report follows the regulations of the Town of Parker - Storm Drainage and Environmental Criteria Manual (SDECM) and Urban Drainage and Flood Control District - Storm Drainage Criteria Manual, Volumes 1-3 (UDFCD Manual).

Hydrologic Criteria

The 5-year and 100-year rainfall events are analyzed for the Parker Adventist Hospital for the minor and major storm events, respectively. The Rational Method, in accordance with the Town of Parker SDECM, is used for runoff calculations.

BASIN B6C

Basin B6C is 0.03 acres in area and is located in the southwest side of the property adjacent to the existing hospital. The surface conditions of the basin consist of pavement and landscaped areas with an impervious value of 82%. Runoff from this basin is conveyed via sheet flow to Design Point 10C. Flows are then routed to Design Point 10B, through the proposed storm sewer system and outfall to the Southwest Detention/Water Quality Pond. The 100-year storm event runoff is calculated to be 0.20 cfs, and the 5-year storm event runoff is calculated to be 0.09 cfs.

BASIN B6D

Basin B6D is 0.02 acres in area and is located in the southwest side of the property adjacent to the existing hospital. The surface conditions of the basin consist of pavement and landscaped areas with an impervious value of 28%. Runoff from this basin is conveyed via sheet flow to Design Point 10D. Flows are then routed to Design Point 10B, through the proposed storm sewer system and outfall to the Southwest Detention/Water Quality Pond. The 100-year storm event runoff is calculated to be 0.09 cfs, and the 5-year storm event runoff is calculated to be 0.03 cfs.

BASIN C7

Basin C7 is re-delineated to incorporate 1.75 acres of tributary area and is located in the Northwest corner of the site. The impervious value for this sub-basin is 45%. Tributary drainage for this sub-basin is conveyed via sheet flow and shallow gutter flow to an existing inlet at design point 18. The flows are then conveyed through existing storm sewer facilities that outfall to the southwest pond. The 100-year storm event runoff is calculated to be 6.76 cfs, and the 5-year storm event runoff is calculated to be 2.28 cfs.

BASIN C8

Basin C8 is 0.48 acres in size and is located in the south-central portion of the site and has an impervious value of 80%. This sub-basin is made up of the loading dock, proposed curb and sidewalk along the east side of the Bed Tower, and landscaped areas. Flows converge from essentially all directions to design point 19 located in the center of the site. The 100-year storm event runoff is calculated to be 2.91 cfs, and the 5-year storm event runoff is calculated to be 1.31 cfs.

BASIN C9

Basin C9 is 0.33 acres in size and is located in the southwestern portion of the site. This sub-basin is made up of road and landscaped areas with an impervious value of 53%. Flows travel easterly to design point 18 located in the southeastern corner of the site. The 100-year storm event runoff is calculated to be 1.75 cfs, and the 5-year storm event runoff is calculated to be 0.63 cfs.

BASIN D4

Basin D4 is 0.67 acres in size and is located in the central portion of the site. This sub-basin is made up of the roof of the hospital with an impervious value of 90%. Flows travel to design point 25 located on the south side of the building. The 100-year storm event runoff is calculated to be 4.95 cfs, and the 5-year storm event runoff is calculated to be 2.37 cfs.

BASIN D7

Basin D7 is 0.67 acres in size and is located in the south portion of the site. This sub-basin is made up of the roof of the bed tower expansion with an impervious value of 90%. Flows

travel to design point 18 located on the south side of the building. The 100-year storm event runoff is calculated to be 4.89 cfs, and the 5-year storm event runoff is calculated to be 2.34 cfs.

A comparison of the flows presented in the previously approved Addendum to the Final Drainage and Erosion Control Report for Parker Adventist Hospital, dated May 29, 2009 and the flows proposed in this Addendum letter is outlined in the following table:

	Previously Approved			Proposed		
	5-yr Direct Runoff (cfs)	100-yr Direct Runoff (cfs)	100-yr Total Runoff (cfs)	5-yr Direct Runoff (cfs)	100-yr Direct Runoff (cfs)	100-yr Total Runoff (cfs)
Design Pt. 25	2.35	4.92	-	2.37	4.95	-
Design Pt. 19	1.42	3.16	-	1.31	2.91	-
Sum at DP 19	-	-	7.85	-	-	7.52
Sum at DP 40	-	-	32.70	-	-	32.59
Sum at DP 18	-	-	11.22	-	-	11.70
Sum at DP 20	-	-	58.99	-	-	59.34
Design Pt. 10C	0.11	0.24	-	0.09	0.20	-
Design Pt. 10D	0.03	0.11	-	0.03	0.09	-
Sum at DP 10B	-	-	0.35	-	-	0.28

The following table verifies that the existing and designed storm facilities have the capacity to convey their respective flows per the pipe capacities outlined in the update to the Final Drainage and Erosion Control Report for Lot M and Bed Tower, dated May 29, 2009.

Pipe	Pipe Capacity (cfs)	Proposed 100-yr Flow (cfs)
DP 10B – DP 10 (18" RCP)	15.31	0.28
DP 19 – DP 40 (18" RCP)	9.79	7.52
DP 18 – DP 20 (24" RCP)	15.61	11.70
DP 40 – DP 20 (30" RCP)	65.39	32.59
DP 20 – DP 21A (36" RCP)	62.65	59.34

The impervious percentage of the site improvements associated with the Bed Tower Project is slightly greater than the impervious percentage used while sizing the southwest detention/water quality pond. However, the sizing of the pond included some flexibility for future development; therefore, no changes to the pond or its outfall structure are proposed.

IV. ENVIRONMENTAL PROTECTION CRITERIA

Erosion Control Criteria

The proposed erosion control program for this site will include the installation of structural erosion control measures including silt fencing, vehicle tracking control, sediment basins and traps; rough cut sheet control and rock check structures. Non-structural measures will include maintaining established grasses until stripping is necessary and the establishment of temporary grasses and permanent grasses in idled or completed areas during construction sequencing.

Construction activities are planned starting in August 2009. According to the town of Parker SDECM, both wind and rainfall erosion can be expected during this time period.

**Parker Adventist Hospital Parking Structure & ED expansion
Drainage Conformance Letter**

Miro Job No. 14004



June 13th, 2014

Denver
Summit County
Abu Dhabi

Tom Williams
Town of Parker
Engineering Development Review
20120 East Main Street
Parker, CO 80138

Civil
Structural
Integrated Services

RE: Parker Adventist Hospital – Parking Structure

Mr. Williams,

This letter serves as a Drainage Conformance Letter for the Parking Structure addition and the ED expansion at the Parker Adventist Hospital. This letter references the Final Drainage and Erosion Control Report for the Parker Adventist Hospital, prepared by S. A. Miro, Inc., dated May 1, 2002. The latest update to the report was for the Bed Tower project, prepared by S. A. Miro, Inc., dated January 6, 2010. More recently there was a Drainage Conformance Letter submitted for this site for the Radiation Therapy Suite addition, prepared by S.A. Miro, Inc., dated December 19, 2012.

The purpose of this letter is to demonstrate the existing and relocated storm sewer facilities serving the improvements for the Parker Adventist Hospital are capable of conveying the runoff generated by the proposed improvements. All tributary drainage from the parking structure and the ED expansion is routed through existing and relocated storm sewer facilities to the southwest detention/water quality pond.

I. PROJECT DESCRIPTION

Improvements that impact the storm sewer facilities are as follows:

- The construction of a two story parking structure, northwest of the main hospital building, with a footprint of 54,444 sq. ft.
- The ED expansion connected to the southeast portion of the main hospital building, with a footprint of 3,289 sq. ft.
- The realignment of the road and parking area to the east and south of the new parking structure.
- The relocation of approximately 570 LF of storm sewer system to replace the existing storm sewer located underneath the proposed parking structure’s footprint.

The Basins that have been modified for these additions are the following, B3, B4, B5, B8, C3, D5, with the addition of these sub-basins, A1-1, B5A, B5B, and B5C. Sub-basin A1-1 is part of basin A1, not imperious area was added to this basin.

	5 Year (cfs)		100 Year (cfs)	
	Proposed	Existing	Proposed	Existing
Outfall of Parking Deck Runoff	15.66	15.79	33.56	35.43
Outfall of ED expansion Runoff	11.27	10.73	24.52	23.81

The revised drainage calculations indicate that between the various improvements, the net result is a decrease in runoff for the improvements that outfall from the parking structure addition and a negligible increase in runoff for the 5 and 100 year storm. The calculations performed to support this letter follow the design criteria set forth in the original drainage report, the Town of Parker Storm Drainage and Environmental Criteria Manual, and the Urban Storm Drainage Criteria Manual.

II. DRAINAGE FACILITY DESIGN

Detention/Water Quality

The Parking Structure and the ED expansion to the Parker Adventist Hospital, and the associated grading and infrastructure improvements, maintains existing drainage. Water quality and detention are currently provided by the southwest detention/water quality pond located at the southwest corner of the site. Since this project has minimal increase to runoff from the existing conditions, no additional detention or water quality measures need to be implemented.

Storm Sewer Relocation

Also required with this project is the relocation of approximately 570 LF of storm sewer. The relocated storm sewer was analyzed using the StormCAD V8i program to ensure that the added pipe length and bends in the manholes cause no negative effects. The hydraulic grade lines are well under the required 1-foot below finish grade at the manholes. Therefore the relocated storm sewer is expected to function adequately to convey the anticipated runoff flows.

III. CONCLUSIONS

Compliance with Standards

This Drainage Conformance Letter complies with the Town of Parker Storm Drainage and Environmental Criteria Manual, the final drainage report for Crown Point and its Addenda, and the Urban Storm Drainage Criteria Manual. The drainage system is designed to efficiently intercept runoff in curb and gutter and storm sewer and convey the flows to the southwest detention/water quality pond. The site provides a drainage system which does not exceed the allowable capacities of the existing storm sewer/drainage facilities.

Please call us if you have any questions.

Sincerely,



Jason D. Carr, P.E.
Associate

J:\Jobs\14004 - PKR Parking Deck\05 CAD\Plans and Details\C351-DRAN-PLAN.dwg C:351 - 6/12/2014

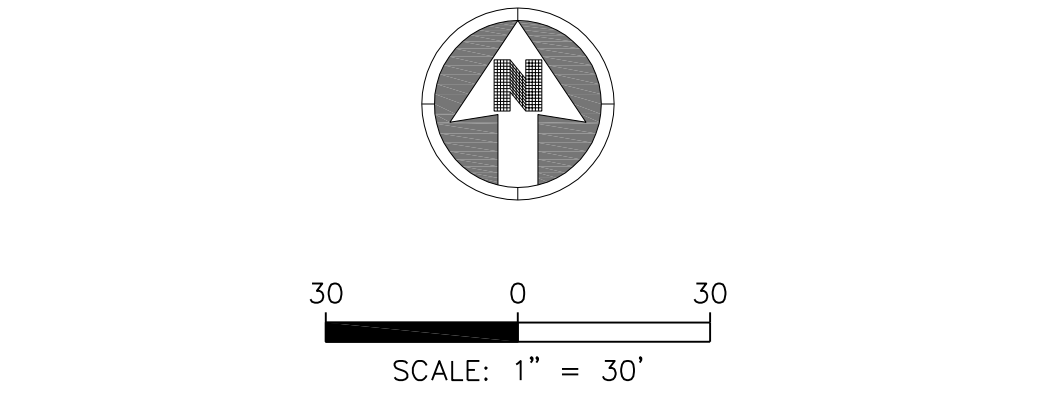

- LEGEND:**
- 43 --- EXISTING MINOR CONTOURS
 - 45 --- EXISTING MAJOR CONTOUR
 - 43 --- PROPOSED MINOR CONTOURS
 - 45 --- PROPOSED MAJOR CONTOURS
 - EX SD --- EXISTING STORM SEWER
 - BASIN BOUNDARY
 - ⊙ PROPOSED MANHOLE
 - PROPOSED INLETS
 - FLOW DIRECTION ARROW
 - ▲ DESIGN POINT DESIGNATION
 - ⊙ B BASIN DESIGNATION
 - ⊙ 0.52 0.73 0.82 INTERMEDIATE YEAR COMPOSITE C
100 YEAR COMPOSITE C
 - BASIN AREA (ACRES)

NOTES:

- SEE SHEET C0.01 FOR GENERAL NOTES AND LEGEND.

COLOR MARK-UPS ADDED FOR AHP HOSPITAL EXPANSION (MIRO JOB #23-079)

RUNOFF SUMMARY							
DESIGN POINT	TRIBUTARY BASINS	DIRECT AREA (ac.)	TRIBUTARY AREA (ac.)	DIRECT RUNOFF			TOTAL RUNOFF
				0-5 (cfs)	0-100 (cfs)	0-5 (cfs)	0-100 (cfs)
PARKING STRUCTURE							
B5A	B5A	0.10	0.10	0.33	0.70	-	-
B5B	B5B,B5C	0.20	0.27	0.51	1.13	0.81	1.79
B5C	B5C	0.08	0.08	0.25	0.54	-	-
T2	B5A,B5B,B5C	-	0.84	-	-	1.13	2.46
X1	X1	3.19	3.19	8.68	18.92	-	-
T3	B5A,B5B,B5C,X1	-	4.03	-	-	9.64	21.04
B4	B4	1.24	1.24	5.26	10.49	-	-
T4	B5A,B5B,B5C,X1,B4	-	5.27	-	-	13.73	29.36
B8	B8	0.18	0.18	0.44	0.83	-	-
X2	X2	0.25	0.25	0.79	1.97	-	-
T5	B8,X2	-	0.43	-	-	1.02	2.06
B5	B8,X2,B5	0.55	0.98	1.60	3.00	2.31	4.50
T7	B5A,B5B,B5C,X1,B4,B5,X2	-	6.25	-	-	14.43	30.48
B3	B3	0.73	0.73	1.75	4.28	-	-
T8	B5A,B5B,B5C,X1,B4,B5,X2,B5,B3	-	6.98	-	-	15.66	33.56
ED EXPANSION							
X3	X3	-	-	9.12	19.95	-	-
D5	D5	0.40	0.40	1.28	2.69	-	-
C3	C3	0.41	0.41	1.25	2.65	-	-
DP15	X3,D5,C3	-	-	-	-	11.27	24.52
OFF SITE							
A1-1	A1-1	0.16	0.16	0.11	0.70	-	-

TOWN OF PARKER SIGNATURE

THE PLANS ARE REVIEWED FOR CONCEPT ONLY AND THE REVIEW DOES NOT IMPLY RESPONSIBILITY BY THE REVIEWING DEPARTMENT, THE DESIGNATED TOWN AUTHORITY OR OTHER APPOINTED PERSON, OR THE TOWN OF PARKER FOR ACCURACY AND CORRECTNESS OF CALCULATIONS, ENGINEERING, OR DESIGN. THE REVIEW DOES NOT IMPLY QUANTITIES REQUIRED. THE REVIEW WILL NOT BE CONSTRUED FOR ANY REASON AS ACCEPTANCE OF FINANCIAL RESPONSIBILITY BY THE TOWN OR REVIEWING DEPARTMENTS FOR ANY COSTS, LABOR, OR MATERIAL THAT MAY BE REQUIRED DURING THE CONSTRUCTION PHASE. REVIEW IS EXCLUSIVELY LIMITED TO TOWN OF PARKER PUBLIC IMPROVEMENTS.

TOWN OF PARKER, PUBLIC WORKS DIRECTOR

TOWN OF PARKER, DESIGNATED TOWN AUTHORITY

TOWN OF PARKER, DESIGNATED TOWN AUTHORITY

PROJECT NUMBER
142360.00

DRAWN BY
SLS

DATE
6/13/14

REV	DESCRIPTION	DATE
1		

BOULDER ASSOCIATES

ARCHITECTS

Boulder Associates, Inc.
Architecture + Interior Design
1426 Pearl Street, Suite 300
Boulder, Colorado 80302
303.499.7795 F 303.499.7767
www.boulderassociates.com

PROJECT
Parker Adventist Hospital Remodel, Addition, and Parking Structure

9395 CROWN CREST BLVD.
PARKER, COLORADO 80138

SITE PACKAGE

SHEET TITLE
DRAINAGE PLAN

SHEET NUMBER
C3.51

**ADDENDUM TO THE FINAL
DRAINAGE AND EROSION
CONTROL REPORT**

FOR

**Parker Adventist Hospital
Parking Lot Expansions**

May 1, 2002
Rev. January 24, 2003
Rev. August 31, 2006
Rev. July 22, 2008
Rev. Letter May 11, 2009
Rev. September 29, 2009
Rev. Letter December 19, 2012
Rev. October 24, 2014
Rev. October 2016
Rev. March 2018

Prepared By:

S. A. Miro, Inc.
Consulting Engineers
4582 South Ulster St. Pkwy., Suite 750
Denver, Colorado 80237
(303) 741-3737
fax (303) 694-3134

S. A. Miro Job No. **15029**

**Addendum to the Final Drainage and Erosion Control Report Parker Adventist Hospital
Parking Expansions**
Miro Job No. 15029

“This report for the drainage design of the **Parker Adventist Hospital Parking Expansions** was prepared by me (or under my direct supervision) in accordance with the provisions of the Town of Parker Storm Drainage and Environmental Criteria Manual, and was designed to comply with the provisions thereof. I understand that the Town of Parker does not, and will not, assume liability for drainage facilities designed by others.”



Jason D. Carr, P.E.
State of Colorado
No. 33854

B. Specific Details

A parking expansion is proposed within the footprint of the existing southwest pond on campus, affecting the overall site drainage design. Through a campus-wide drainage analysis, we've evaluated existing conditions and proposed and future developments against current drainage standards, and have devised a solution to provide improved stormwater treatment for the full campus within a smaller footprint. The proposal includes revisions to the south pond's existing orifices, and new grading, forebays, trickle channels, and outlet structure within the southwest pond.

The as-built conditions of the south pond show an excess of volume, however, the existing orifice sizes preclude the oversized pond from detaining to maximum potential in the 100-year condition. We are proposing reduced orifices on the south pond's 10-year and 100-year outlets such that the pond can maximize its volume potential. The pond has been evaluated by the UD-Detention v3.07 spreadsheet to determine full volume potential, available in the Appendix.

As a result of the higher detention volume and lower release rate achieved in the south pond, the proposed southwest pond will release at a higher rate. The proposed condition of the southwest pond is designed to provide full water quality and EURV volume and release rates for the tributary area. Together, the two ponds meet the minimum storage volume and runoff rate requirements for the site, as detailed in Table 2 below, with supporting information included in the Appendix.

POND	100-YR VOLUMES (ac-ft)		100-YR RELEASE RATE (cfs)		
	EXISTING	PROPOSED	EXISTING	PROPOSED	ALLOWABLE
South	1.71	2.3	33	5.8	19.5
Southwest	3.54	1.98	33	33.2	19.5
Total	5.25	4.28	66	39	39

Notes:

- 1) Existing SW Pond values extracted from 2010 Detention Basin Volume Certification.
- 2) The existing south pond volume was calculated through UD-Detention, using existing orifice sizes and pond geometry.
- 3) Required values were calculated by the UD-Detention v3.07 spreadsheet. The individual pond values add up to more than the combined, due to the intricacies of the calculations and the slight variances that come from the individual split calculations.
- 4) Existing release rates are from the 2002 Final Drainage and Erosion Control Report.

The proposed release rate has been reduced from the existing condition, bringing the entire site into compliance with current rate requirements. Our proposed design will maximize use of the hospital's land, provide improved water quality treatment and sufficient capacity for a 100-year storm. Additional design information and calculations are included in the Appendix.

C. Discussion of Detention Storage Required for Full-Spectrum Detention

Southwest pond – The existing capacity of the southwest pond is 3.54 acre feet (Appendix A). During a 100-yr event, with a release rate of 33.2 cfs, bound within the geometry of the proposed pond design, while maintaining the existing spillway elevation, the maximum volume stored will

**Addendum to the Final Drainage and Erosion Control Report Parker Adventist Hospital
Parking Expansions**
Miro Job No. 15029

be 1.98 acre-feet. The Southwest pond has an offsite tributary basin, OS-1. This basin contributes 28.64 cfs in the 100-yr storm, and enters the site through design point 28 on the drainage plan. This minimal offsite runoff has been accounted for in sizing the existing and proposed storm sewer infrastructure, but is not considered into the required detention volume. The offsite flows simply pass through the southwest detention pond. The total ponding depth is less than 1/4" over the spillway elevation in the 100-yr condition when accounting for the offsite runoff. The spillway use in the 100-year condition is considered negligible.

South pond – The existing capacity of the south pond is 3.28 acre feet (Appendix A), although the maximum detained volume in the 100-yr event is only 1.71 acre feet. With the proposed orifice plate adjustments, the pond will release only 5.8 cfs in the 100-yr event, and will store 2.3 acre-feet of water. The south pond has enough excess volume that the full volume of runoff will be contained within the pond in the 100-year condition, including the runoff from the offsite tributary basin, OS-2.

These changes maximize the storage volume proposed on site, eliminate wasted storage space, decrease total site release rates to comply with current standards and increase the overall level of water quality treatment achieved.

Please refer to the Appendix for the associated calculations.

D. Discussion of Outlet Requirements

Using the storage chapter within the Urban Storm Drainage Criteria Manual Volume 2, the peak pre-developed discharge rate for the full project site was calculated to be 39 cfs. Previous drainage reports, along with as-built information, tell us that the existing south pond and southwest ponds were constructed with a combined 100 year release rate of 66 cfs. Using the current design standards, the revised total site release rate is required to be 39 cfs.

To accommodate the proposed parking lot expansion, the orifice of the south pond will be modified to release at a slower rate of 5.8 cfs, allowing the southwest pond to release at a higher rate of 33.2 cfs, for a total site release rate of 39 cfs. With an updated allowable release rate, the existing outlet structure for the southwest pond will be removed and replaced with a new structure. The new outlet structure has been designed in accordance with the Parker SDECM, as well as current UDFCD criteria.

The existing southwest pond emergency spillway will remain intact. The south pond will remain intact; however, the orifice plate for the 10-yr and 100-yr event on the outlet structure will be re-sized to release the approved outflow rate.

Any variances or exceptions to the design have been noted. Critical volumes, release rates and other important pond design criteria were calculated using the spreadsheets provided by Urban Drainage. Refer to the Appendix for all calculations and further information regarding the outlet structure design.

E. Discussion of Storm Sewer Configuration

The capacity of both existing and proposed storm sewer pipes which were affected by the proposed design changes to the site have been evaluated and sized accordingly. StormCAD models and FlowMaster calculations were utilized to ensure adequate sizing and meet the capacity requirements set by the Town of Parker. Hydraulic grade lines and energy grade lines for the 100-yr and 10-yr storm event have been placed in the storm plan and profiles provided in the Appendix. UD-inlet sizing software for Type R inlets was utilized to ensure adequate size and

POND VOLUME CALCULATIONS

SUBDIVISION

Parker Adventist Hospital

CALCULATED BY

bec.SAKK

DATE

10/9/2007

South Pond

POND DESIG	ELEV	AS-BUILT ELEV	AREA (ft ²)	AS-BUILT AREA	VOLUME (ft ³)	AS-BUILT VOLUME (ft ³)	VOLUME _{sum} (ft ³)	AS-BUILT VOLUME _{sum} (ft ³)	METHOD
South Detention Pond	5812.5	5812.5	259	136	0	1	0	1	prismoidal
	5813	5813	426	300.9	169.53	106.53	169.53	107.53	
	5814	5814	836	356.72	619.59	328.41	789.12	435.95	
	5815	5815	1346	616	1,080.93	480.35	1,870.04	916.30	
	5815.33	5815.33	1536	5879.5	475.19	2,799.27	2,345.23	3,715.57	
	5816	5816	5649	17634.26	2,262.51	11,232.04	4,607.74	14,947.61	
	5817	5817	15122	28890.67	10,004.51	23,032.09	14,612.25	37,979.70	
	5818	5818	30029	34994.2	22,153.53	31,893.73	36,765.78	69,873.43	
	5819	5819	35427	40240.75	32,690.84	37,586.95	69,456.62	107,460.38	
	5820	5820	40551	45798.39	40240.75	37,960.17	107,416.79	150,450.00	
	5821	5821	43976		42,251.93	42,989.62	149,668.72		

DESIGN VOLUME	AS-BUILT VOLUME AT DESIGN ELEVATION	PERCENT INCREASE FROM DESIGN		DESIGN ELEVATION AT WHICH DESIGN VOLUME IS MET	AS-BUILT
$V_{WQ}(ac-ft) = 0.67$			By Interpolation	$Elev_{WQ}(ft) = 5817.66$	5817.62
$V_{WQ}(ft^3) = 29,185.20$	30,098.49	3.03%	By Interpolation	$Elev_{10}(ft) = 5819.43$	5819.42
$V_{10}(ac-ft) = 1.97$			By Interpolation	$Elev_{100}(ft) = 5820.83$	5820.81
$V_{10}(ft^3) = 85,813.20$	86,069.20	0.30%			
$V_{100}(ac-ft) = 3.27$	143,096.30	0.46%			

3.285 ac-ft

Town Of Parker

Detention Basin Volume Certification Standard Form

** This Document Must Be Prepared, Signed and Stamped By A
Colorado Registered Professional Engineer*

1	Project Name	Parker Adventist Hospital	Date:	4/26/2010	
2	Detention Facility Name / Description	SW Detention Pond			P.E. #
3	Design Water Quality Volume	0.61 acre-feet	As Constructed Water Quality Volume	0.47 acre-feet	
	Design Water Quality WSE	5794.97	As- Constructed Water Quality WSE	5795.02	
4	Design 10-year Volume	2.01 acre-feet	As Constructed 10-year Volume	1.81 acre-feet	
	Design 10-year WSE	5796.83	As- Constructed 10-year WSE	5796.83 feet	
5	Design 100-year Volume	3.51 acre-feet	As Constructed 100-year Volume	3.54 acre-feet	ex provided vol
	Design 100-year WSE	5798.4 feet	As- Constructed 100-year WSE	5798.62 feet	
6	Design 10-year Weir / Orifice Elevation	5794.97 feet	As-Constructed 10-year Weir /Orifice Elevation	5795.02 feet	
7	Design 100-year Weir / Orifice Elevation	5796.83 feet	As-Constructed 100-year Weir / Orifice Elevation	5796.83 feet	
8	Design Outlet Structure Outlet Pipe Invert	5793.66 feet	As Constructed Outlet Structure Pipe Invert	5793.7 feet	
9	Design Overflow Spillway Crest Elevation	5799.4 feet	As-Constructed Overflow Spillway Crest Elevation	5799.58 feet	
10	Design Overflow Spillway Crest Length	31 feet	As-Constructed Overflow Spillway Crest Length	19 feet	
11	Design Berm Elevation (Lowest Point)	5799.4 feet	As -Constructed Berm Elevation (Lowest Point)	5799.58 feet	

* Water Surface Elevation = WSE



S.A. MIRO, INC.
CONSULTING ENGINEERS
4582 South Ulster Street Pkwy.
Suite 750 Denver, CO 80237
ph. 303 741 3737
fax 303 694 3134



Know what's below.
Call before you dig.

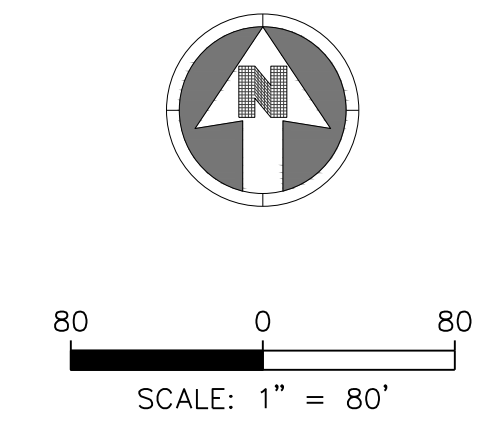

LEGEND:

- 43--- EXISTING MINOR CONTOURS
- 45--- EXISTING MAJOR CONTOUR
- 43— PROPOSED MINOR CONTOURS
- 45— PROPOSED MAJOR CONTOURS
- — — EX SD EXISTING STORM SEWER
- — — BASIN BOUNDARY
- ⊕ PROPOSED MANHOLE
- ⊕ PROPOSED INLETS
- FLOW DIRECTION ARROW

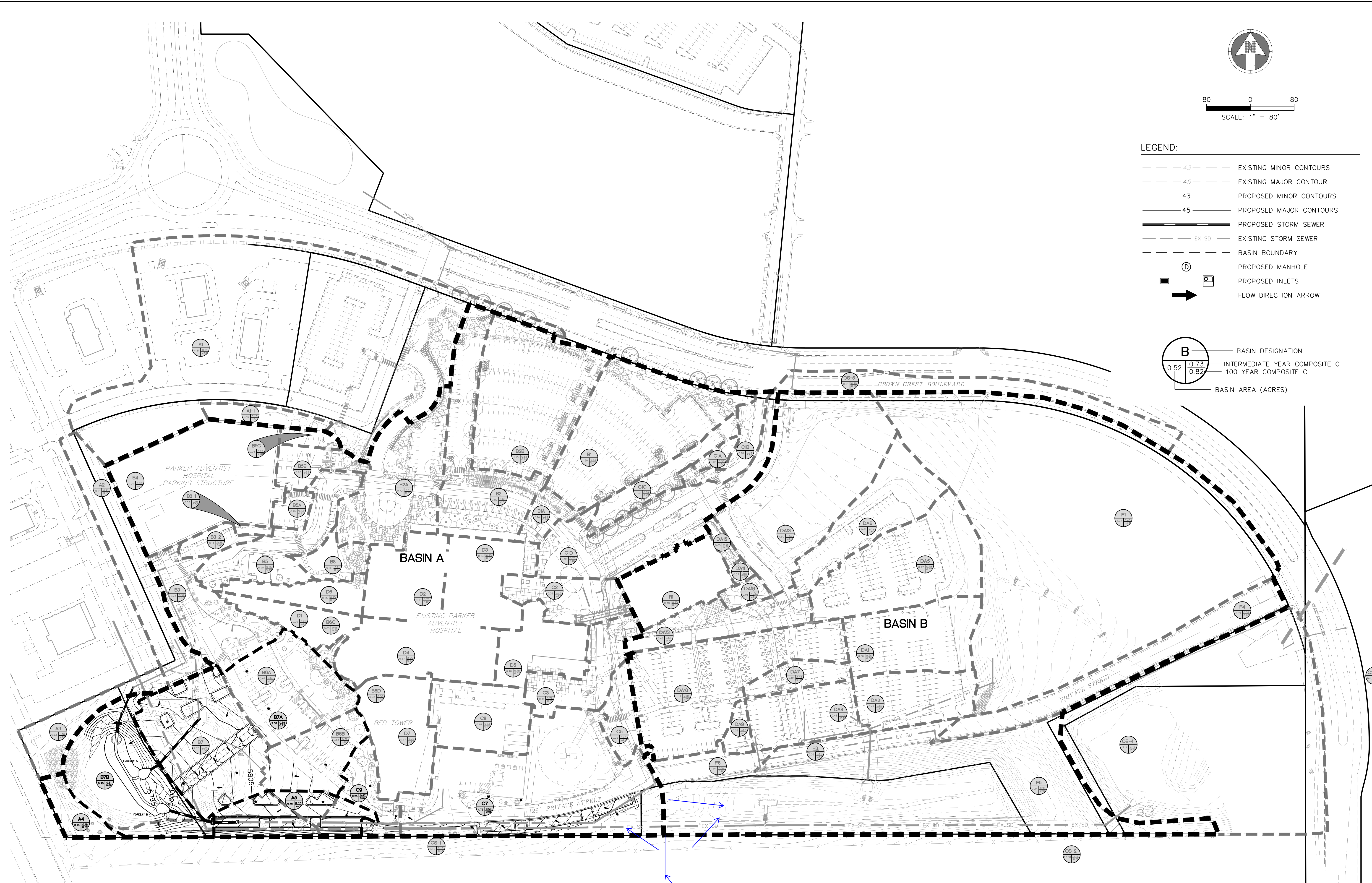
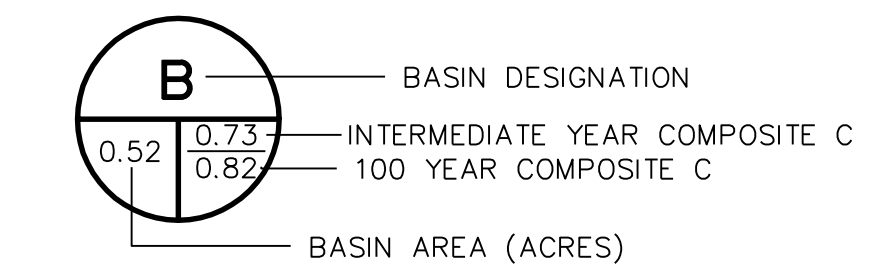

REV.	DESCRIPTION	DATE
1	INITIAL SUBMITTAL TO CITY	03/08/17
2	SECOND CITY SUBMITTAL	09/15/17
3		
4		
5		
6		
7		
8		

CLIENT NAME: PARKER ADVENTIST HOSPITAL
PROJECT NAME: PARKING LOT EXPANSION
DRAWING TITLE: 9395 CROWN CREST BLVD. DRAINAGE MAP

NOT FOR CONSTRUCTION

DESIGNED BY: MHV
DRAWN BY: DAT
CHECKED BY: JDC
DATE: 09/15/2017
MIRO JOB NUMBER: 15029
CLIENT JOB NUMBER: []

DRAWING NUMBER: FIG. 2

THE TOWN OF PARKER REVIEW CONSTITUTES GENERAL COMPLIANCE WITH THE TOWN'S STANDARDS AND APPROVED VARIANCES, SUBJECT TO THESE PLANS BEING STAMPED, SIGNED, AND DATED BY THE PROFESSIONAL ENGINEER OF RECORD. REVIEW BY THE TOWN DOES NOT CONSTITUTE APPROVAL OF THE PLANS DESIGN OR ACCURACY AND CORRECTNESS OF ENGINEERING CALCULATIONS. ERRORS IN THE DESIGN OR CALCULATIONS REMAIN THE RESPONSIBILITY OF THE REGISTERED PROFESSIONAL ENGINEER WHOSE STAMP AND SIGNATURE ARE AFFIXED TO THIS DOCUMENT.

THIS REVIEW DOES NOT CONSTITUTE APPROVAL OF ANY PRIVATE ON-SITE IMPROVEMENTS WHICH MAY BE SHOWN. CONSTRUCTION CANNOT COMMENCE UNTIL ALL REQUIRED DRAINAGE/TRAFFIC REPORTS(S), FINAL DEVELOPMENT PLAN(S), SPECIAL REVIEW(S), GRADING PERMIT, AND/OR OTHER PERMITS ARE COMPLETE, APPROVED AND ON FILE WITH THE TOWN OF PARKER

Parker Adventist Hospital MOB III



November 15, 2018

Town of Parker
Engineering Development Review
20120 East Main Street
Parker, CO 80138

Denver

Abu Dhabi

RE: Parker Adventist Hospital – MOB III

Civil
Structural
Integrated Services

To whom it may concern,

This letter serves as a Drainage Conformance Letter for the MOB III addition at the Parker Adventist Hospital. This letter references the Final Drainage and Erosion Control Report for the Parker Adventist Hospital, prepared by S. A. Miro, Inc., dated May 1, 2002. The latest update to the report was for the Parking Lot a, prepared by S. A. Miro, Inc., dated March, 2018.

The purpose of this letter is to demonstrate the existing and proposed storm sewer facilities serving the improvements for the Parker Adventist Hospital can convey the runoff generated by the proposed MOB III. All tributary drainage from the MOB is routed through existing and proposed storm sewer facilities to the south detention/water quality pond.

I. PROJECT DESCRIPTION

Improvements that impact the storm sewer facilities are as follows:

- The construction of Medical Office Building III, located northeast of the Sierra MOB, with a footprint of 23,288 sq. ft.
- Proposed parking lot, with an added impervious area of 151,740 sq. ft. (188,840 sq. ft. total parking lot area)
- The addition of approximately 1,185 LF of proposed storm sewer pipe and 12 proposed inlets.

The sub-basins that have been modified for these additions are the following, DA5, DA6, DA13, and F1, with the addition of sub-basins E1-E15.

The Parker Adventist Hospital campus was master planned with the anticipation of the entire campus to be fully developed. While the proposed development is increasing imperviousness, it is still within the planned overall imperviousness. The existing storm infrastructure was sized with future development in mind and can convey increased flows to the South pond. The proposed design is accounting for future development to be conveyed through the system as well. See the appendix for further information regarding storm sewer conveyance.

II. DRAINAGE FACILITY DESIGN

Detention/Water Quality

All proposed storm runoff will be conveyed via storm pipe and discharged to the South pond. The South pond has been master planned to detain and treat the eastern half of the Parker Adventist Hospital site in a future, fully-developed condition.

Parker Adventist Hospital MOB III

Storm Sewer Layout

The proposed storm sewer system will tie into the existing infrastructure at three different locations. The roof drain will connect into an existing storm line which previously led to an inlet but is being removed. Storm line B will tie into an existing area inlet located at the north end of existing parking lot C. Storm line A will tie into the 24" PVC line that currently takes on flows from basin F1, but as designed with the intention of taking on future development flows. The proposed storm sewer was analyzed using the StormCAD V8i program to ensure that the added storm infrastructure does not overwhelm the existing system. The hydraulic grade lines are under the required 1-foot below finish grade at the manholes. The system was checked against flows in the 100-yr condition, but Parker minimum pipe size standards (18" RCP) drove a majority of the pipe sizes. Therefore, the existing and proposed storm sewer is expected to function adequately to convey the anticipated runoff flows.

III. CONCLUSIONS

Compliance with Standards

This Drainage Conformance Letter complies with the Town of Parker Storm Drainage and Environmental Criteria Manual, and the Urban Storm Drainage Criteria Manual. The drainage system is designed to efficiently intercept runoff in curb and gutter and storm sewer and convey the flows to the South detention/water quality pond. The site provides a drainage system which does not exceed the allowable capacities of the existing storm sewer/drainage facilities.

Please call us if you have any questions.

Sincerely,



Jason D. Carr, P.E.
Associate Principle

IV. APPENDICIES

- a. HYDROLOGIC CALCULATIONS
- b. HYDRAULIC CALCULATIONS
- c. MAPS



Historic Composite C Calculations

Project Information
 Project Name: MOB III
 Miro Project No: 18057
 Revised Date: 8/7/2018
 Calculated By: MHV

Jurisdiction Impervious Value
 Pond Area 100% Impervious
 Landscape Area 0% Impervious
 Paved Area 100% Impervious
 Roof Area 90% Impervious

Coefficient Equations
 $K_{CD(2)} = 0$ $K_{CD(10)} = -0.18i + 0.21$
 $K_{CD(5)} = -0.10i + 0.11$ $K_{CD(100)} = -0.39i + 0.46$
 $C_{CD} = K_{CD} + (0.858i^3 - 0.786i^2 + 0.774i + 0.04)$

*NOTE: K_{CD} & C_{CD} Equations from UDFCD Criteria Manual

Basin Designation	A _{pond} (ft ²)	A _{landscape} (ft ²)	A _{paved} (ft ²)	A _{roof} (ft ²)	A _{total} (acres)	Impervious-ness	K _{CD} 02-yr	K _{CD} 05-yr	K _{CD} 10-yr	K _{CD} 100-yr	C _{CD} 02 yr	C _{CD} 05 yr	C _{CD} 10 yr	C _{CD} 100 yr
*A1					4.61	67%	0	0.04	0.09	0.20	0.46	0.51	0.55	0.66
*A2					0.71	52%	0	0.06	0.12	0.26	0.35	0.41	0.47	0.61
*A3					0.32	2%	0	0.11	0.21	0.45	0.06	0.16	0.26	0.51
A4		7131	515		0.18	7%	0	0.10	0.20	0.43	0.09	0.19	0.29	0.52
A5		5045	15105		0.46	75%	0	0.04	0.08	0.17	0.54	0.57	0.62	0.71
B1#					1.20	80%	0	0.03	0.07	0.15	0.60	0.63	0.66	0.74
B1A#					0.14	80%	0	0.03	0.07	0.15	0.60	0.63	0.66	0.74
B2#					0.82	85%	0	0.03	0.06	0.13	0.66	0.68	0.71	0.79
B2A#					0.73	79%	0	0.03	0.07	0.15	0.58	0.61	0.65	0.74
B2B#					1.15	85%	0	0.03	0.06	0.13	0.66	0.68	0.71	0.79
B3***					0.73	67%	0	0.04	0.09	0.20	0.46	0.51	0.55	0.66
B3-1***					0.03	0%	0	0.11	0.21	0.46	0.04	0.15	0.25	0.50
B3-2***					0.14	60%	0	0.05	0.10	0.23	0.41	0.46	0.51	0.63
B4***					1.24	100%	0	0.01	0.03	0.07	0.89	0.90	0.92	0.96
B5***					0.55	72%	0	0.04	0.08	0.18	0.51	0.55	0.59	0.69
B5A***					0.10	89%	0	0.02	0.05	0.11	0.71	0.73	0.76	0.82
B5B***					0.20	80%	0	0.03	0.07	0.15	0.60	0.63	0.66	0.74
B5C***					0.08	88%	0	0.02	0.05	0.12	0.70	0.72	0.75	0.81
B6A(EX)**					0.67	78%	0	0.03	0.07	0.16	0.57	0.60	0.64	0.73
B6B(EX)					0.53	87%	0	0.02	0.05	0.12	0.68	0.71	0.74	0.80
B6C**					0.03	82%	0	0.03	0.06	0.14	0.62	0.65	0.68	0.76
B6D**					0.02	28%	0	0.08	0.16	0.35	0.21	0.30	0.37	0.56
B7 (EX)*					2.20	37%	0	0.07	0.14	0.32	0.26	0.34	0.41	0.58
B7A		21,047	69,660		2.08	77%	0	0.03	0.07	0.16	0.56	0.59	0.63	0.72
B7B	26319	12,883			0.90	67%	0	0.04	0.09	0.20	0.47	0.51	0.55	0.66
B8***					0.18	11%	0	0.10	0.19	0.42	0.12	0.22	0.31	0.53
C1A#					0.05	41%	0	0.07	0.14	0.30	0.28	0.35	0.42	0.58
C1B#					0.18	47%	0	0.06	0.13	0.28	0.32	0.38	0.44	0.60
C1C#					0.31	86%	0	0.02	0.06	0.12	0.67	0.69	0.73	0.79
C1D#					0.93	89%	0	0.02	0.05	0.11	0.71	0.73	0.76	0.82
C2#					0.36	92%	0	0.02	0.04	0.10	0.75	0.77	0.80	0.86
C3***					0.41	88%	0	0.02	0.05	0.12	0.70	0.72	0.75	0.81
C5#					0.22	50%	0	0.06	0.12	0.27	0.34	0.40	0.46	0.60
C7 (EX)**					1.75	45%	0	0.07	0.13	0.28	0.31	0.37	0.44	0.59
C7		26,034	50,346		1.75	66%	0	0.04	0.09	0.20	0.45	0.50	0.55	0.66
C8**					0.48	80%	0	0.03	0.07	0.15	0.60	0.63	0.66	0.74
C9		4,162	6,898		0.25	62%	0	0.05	0.10	0.22	0.43	0.47	0.52	0.64
D1#					0.26	90%	0	0.02	0.05	0.11	0.73	0.75	0.77	0.83
D2#					0.49	90%	0	0.02	0.05	0.11	0.73	0.75	0.77	0.83
D3#					0.53	90%	0	0.02	0.05	0.11	0.73	0.75	0.77	0.83
D4**					0.67	90%	0	0.02	0.05	0.11	0.73	0.75	0.77	0.83
D5***					0.40	90%	0	0.02	0.05	0.11	0.73	0.75	0.77	0.83
D6#					0.25	90%	0	0.02	0.05	0.11	0.73	0.75	0.77	0.83
D7**					0.67	90%	0	0.02	0.05	0.11	0.73	0.75	0.77	0.83
DA1#					0.66	71%	0	0.04	0.08	0.18	0.50	0.54	0.58	0.68
DA2#					0.47	95%	0	0.02	0.04	0.09	0.80	0.82	0.84	0.89
DA5#					0.97	93%	0	0.02	0.04	0.10	0.77	0.79	0.81	0.87
DA6#					0.61	50%	0	0.06	0.12	0.27	0.34	0.40	0.46	0.60
DA7#					0.19	96%	0	0.01	0.04	0.09	0.82	0.83	0.85	0.90
DA8#					0.48	88%	0	0.02	0.05	0.12	0.70	0.72	0.75	0.81
DA9#					0.08	74%	0	0.04	0.08	0.17	0.53	0.57	0.61	0.70
DA10#					1.17	99%	0	0.01	0.03	0.07	0.87	0.88	0.90	0.94
DA11#					0.03	4%	0	0.11	0.20	0.44	0.07	0.18	0.27	0.51
DA12#					0.43	76%	0	0.03	0.07	0.16	0.55	0.58	0.62	0.71
DA13*					1.50	69%	0	0.04	0.09	0.19	0.48	0.52	0.57	0.67
DA15#					0.05	20%	0	0.09	0.17	0.38	0.17	0.26	0.34	0.55
DA16#					0.08	57%	0	0.05	0.11	0.24	0.38	0.44	0.49	0.62
OS-1*					6.40	2%	0	0.11	0.21	0.45	0.06	0.16	0.26	0.51
OS-2*					12.80	2%	0	0.11	0.21	0.45	0.06	0.16	0.26	0.51
OS-3*					164.50	2%	0	0.11	0.21	0.45	0.06	0.16	0.26	0.51
OS-4*					3.11	2%	0	0.11	0.21	0.45	0.06	0.16	0.26	0.51
OS-5*					0.54	100%	0	0.01	0.03	0.07	0.89	0.90	0.92	0.96
F1*					5.37	63%	0	0.05	0.10	0.21	0.43	0.48	0.53	0.64
R1#					0.48	90%	0	0.02	0.05	0.11	0.73	0.75	0.77	0.83
F3*					0.36	69%	0	0.04	0.09	0.19	0.48	0.52	0.57	0.67
F4*					0.69	73%	0	0.04	0.08	0.18	0.52	0.56	0.60	0.70
F5#					2.24	100%	0	0.01	0.03	0.07	0.89	0.90	0.92	0.96
F6*					0.23	71%	0	0.04	0.08	0.18	0.50	0.54	0.58	0.68
					0.00									
South Pond Trib					28.89	44%	0	0.07	0.13	0.29	0.30	0.37	0.43	0.59
SW Pond Trib					25.40	61%	0	0.05	0.10	0.22	0.41	0.46	0.51	0.64
Total Onsite					54.29	52%	0	0.06	0.12	0.26	0.35	0.41	0.46	0.61

From Addendum to Final Drainage Plan dated 7/22/2008

* Approved Master Planned Impervious Values used

** From Update dated 1/6/2010

*** From Update dated 6/13/2014

Master Basin B	6.72	80%
	9.37	74%
	12.80	2%
Master Basin A	8.36	82%
	5.62	75%
	5.76	81%
	6.40	2%

Values used for ex. req'd volume

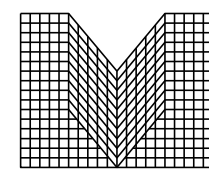

S.A. MIRO INC.
CONSULTING ENGINEERS

4582 South Ulster Street Pkwy.
Suite 750 Denver, CO 80237
ph. 303-741-3737
fax 303-694-3134



Know what's below.
Call before you dig.

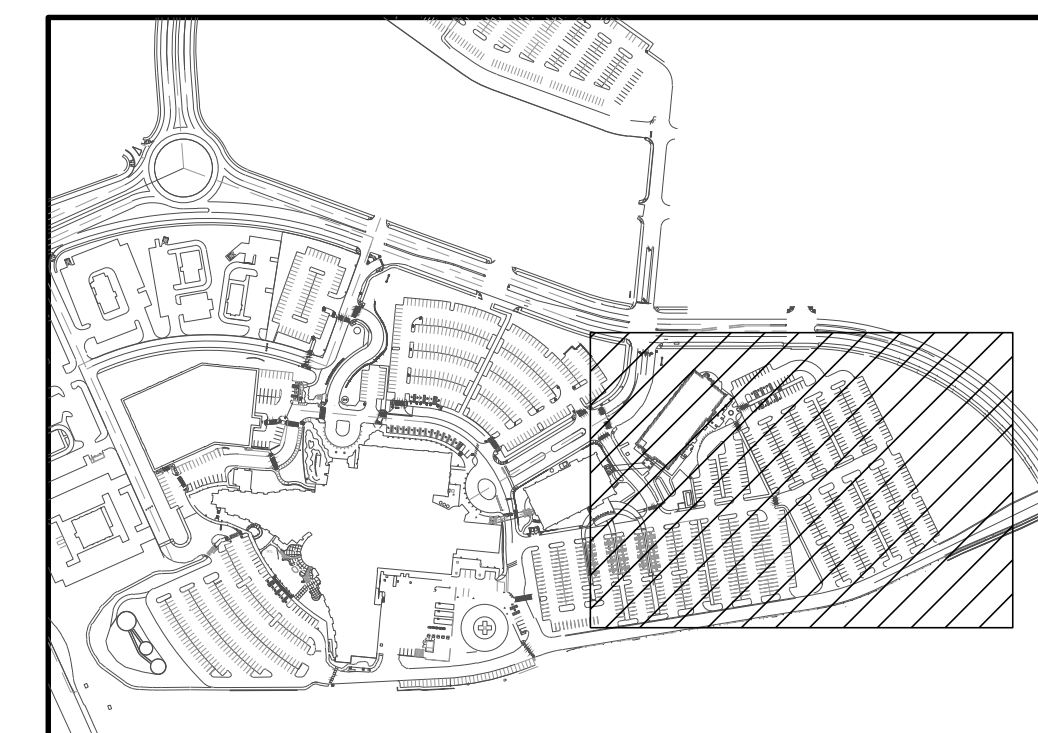

KEY MAP

NOT TO SCALE

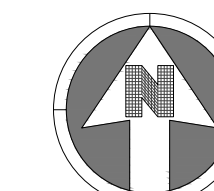

40 0 40

SCALE: 1" = 40'

NOTES:

- SEE SHEET C-001 FOR CIVIL NOTES AND LEGEND.

LEGEND:

- - - - - 43 - - - - - EXISTING MINOR CONTOURS
- - - - - 45 - - - - - EXISTING MAJOR CONTOUR
- - - - - 43 - - - - - PROPOSED MINOR CONTOURS
- - - - - 45 - - - - - PROPOSED MAJOR CONTOURS
- — — — — PROPOSED STORM SEWER
- - - - - EX SD - - - - - EXISTING STORM SEWER
- — — — — BASIN BOUNDARY
- ⊙ PROPOSED MANHOLE
- PROPOSED INLETS
- FLOW DIRECTION ARROW
- △ XX DESIGN POINT DESIGNATION
- ⊙ B BASIN DESIGNATION
- ⊙ 0.52 0.73 0.82 INTERMEDIATE YEAR COMPOSITE C
100 YEAR COMPOSITE C
- ⊙ BASIN AREA (ACRES)

RUNOFF SUMMARY

DESIGN POINT	TRIBUTARY BASINS	TRIBUTARY AREA (ac.)	DIRECT RUNOFF (cfs)		TOTAL RUNOFF (cfs)	
			Q-5	Q-100	Q-5	Q-100
			(cfs)	(cfs)	(cfs)	PEAK(cfs)
1	E1, E2, DA11, DA15, DA16	1.07	-	-	1.71	5.25
2	E6, E7	0.99	1.39	3.56	1.44	4.45
3	E6, E7, E8	1.09	0.27	0.63	1.66	4.94
4	E6-E8, E4	1.42	0.86	1.96	2.36	6.52
5	E6-E8, E3, E4	1.63	0.63	1.44	2.82	7.57
6	E6-E8, E3, E4, DA1	2.01	1.69	3.91	4.24	10.87
7	E3-E8, DA1	2.67	0.97	2.24	5.05	12.73
8	E1-E8, DA1, DA11, DA15, DA16	3.74	-	-	6.68	17.80
9	F1, E12, E13	2.55	0.98	2.05	1.90	8.54
10	E14	0.49	1.90	3.74	1.90	3.74
11	F1, E12-E14	3.04	-	-	3.13	10.95
12	F1, E11-E14	3.67	2.46	4.83	4.69	13.98
13	E9, E10	1.13	2.24	3.44	3.91	7.94
14	F1, E9-E14	4.80	-	-	7.34	19.34
15	DP8, DP14	8.54	-	-	22.06	53.50

THE TOWN OF PARKER REVIEW CONSTITUTES GENERAL COMPLIANCE WITH THE TOWN'S STANDARDS AND APPROVED VARIANCES, SUBJECT TO THESE PLANS BEING STAMPED, SIGNED, AND DATED BY THE PROFESSIONAL ENGINEER OF RECORD. REVIEW BY THE TOWN DOES NOT CONSTITUTE APPROVAL OF THE PLANS DESIGN OR ACCURACY AND CORRECTNESS OF ENGINEERING CALCULATIONS, ERRORS IN THE DESIGN OR CALCULATIONS REMAIN THE RESPONSIBILITY OF THE REGISTERED PROFESSIONAL ENGINEER WHOSE STAMP AND SIGNATURE ARE AFFIXED TO THIS DOCUMENT.

THIS REVIEW DOES NOT CONSTITUTE APPROVAL OF ANY PRIVATE ON-SITE IMPROVEMENTS WHICH MAY BE SHOWN. CONSTRUCTION CANNOT COMMENCE UNTIL ALL REQUIRED DRAINAGE/TRAFFIC REPORT(S), FINAL DEVELOPMENT PLAN(S), SPECIAL REVIEW(S), GRADING PERMIT, AND/OR OTHER PERMITS ARE COMPLETE, APPROVED AND ON FILE WITH THE TOWN OF PARKER.

TOWN OF PARKER, DIRECTOR OF ENGINEERING

DATE



UPSTREAM FLOW AT EAST CONNECTION

EXISTING INLET BEING REPLACED

REV.	DESCRIPTION	DATE
1		
2		
3		
4		
5		
6		
7		
8		

CLIENT NAME: **PARKER ADVENTIST HOSPITAL**
PROJECT NAME: **PARKER MOB III**
DRAWING TITLE: **9403 CROWN CREST BLVD. DRAINAGE MAP**

FILE PATH: J:\Jobs\18057 Parker MOB III\04 Civil Design\Drainage\Drainage Plan Fig-01.dwg Fig-1.0 - 10/17/2018

NOT FOR CONSTRUCTION

DESIGNED BY: DAT
DRAWN BY: DAT
CHECKED BY: MHV
DATE: 10/15/2018

MIRO JOB NUMBER: 18057
CLIENT JOB NUMBER: [blank]

DRAWING NUMBER: **FIG. 1**

NOTES TO USERS

This map is for use in administering the National Flood Insurance Program. It does not necessarily identify all areas subject to flooding, particularly from local drainage sources of small size. The **community map repository** should be consulted for possible updated or additional flood hazard information.

To obtain more detailed information in areas where **Base Flood Elevations (BFEs)** and/or **floodways** have been determined, users are encouraged to consult the Flood Profiles and Floodway Data and/or Summary of Stillwater Elevations tables shown on this FIRM. Users should be aware that BFEs shown on the FIRM represent rounded whole-foot elevations. These BFEs are intended for flood insurance rating purposes only and should not be used as the sole source of flood elevation information. Accordingly, flood elevation data presented in the Flood Profiles and Floodway Data and/or Summary of Stillwater Elevations tables should be utilized in conjunction with the FIRM for purposes of construction and/or floodplain management.

Boundaries of the **floodways** were computed at cross sections and interpolated between cross sections. The floodways were based on hydraulic considerations with regard to requirements of the National Flood Insurance Program. Floodway widths and other pertinent floodway data are provided in the Floodway Data table shown on this FIRM.

The **projection** used in the preparation of this map was Universal Transverse Mercator (UTM) zone 13. The **horizontal datum** was NAD 83, GRS 1980 spheroid. Differences in datum, spheroid, projection or UTM zones used in the production of FIRMs for adjacent jurisdictions may result in slight positional differences in map features across jurisdiction boundaries. These differences do not affect the accuracy of this FIRM.

Flood elevations on this map are referenced to the North American Vertical Datum of 1988. These flood elevations must be compared to structure and ground elevations referenced to the same **vertical datum**. For information regarding conversion between the National Geodetic Datum of 1929 and the North American Vertical Datum of 1988, visit the National Geodetic Survey website at <http://www.ngs.noaa.gov> or contact the National Geodetic Survey at the following address:

NGS Information Services
NOAA, N/NGS-12
National Geodetic Survey
SSMC-3, #9202
1315 East-West Highway
Silver Spring, Maryland 20910-3282
(301) 713-3242

To obtain current elevation, description, and/or location information for **bench marks** shown on this map, please contact the Information Services Branch of the National Geodetic Survey at (301) 713-3242, or visit its website at <http://www.ngs.noaa.gov>.

Base map information shown on this FIRM was provided by the Douglas County GIS Department and the Town of Castle Rock GIS Department. Additional input was provided by the City of Lone Tree and Town of Parker. These data are current as of 2010.

Certain areas not in Special Flood Hazard Areas may be protected by **flood control structures**. Refer to Section 2.4 "Flood Protection Measures" of the Flood Insurance Study report for information on flood control structures for this jurisdiction.

The **profile baselines** depicted on this map represent the hydraulic modeling baselines that match the flood profiles in the FIS report. As a result of improved topographic data, the **profile baseline**, in some cases, may deviate significantly from the channel centerline or appear outside the SFHA.

Based on updated topographic information, this map reflects more detailed and up-to-date **stream channel configurations and floodplain delineations** than those shown on the previous FIRM for this jurisdiction. As a result, the Flood Profiles and Floodway Data tables for multiple streams in the Flood Insurance Study Report (which contains authoritative hydraulic data) may reflect stream channel distances that differ from what is shown on the map. Also, the road to floodplain relationships for unrevised streams may differ from what is shown on previous maps.

Corporate limits shown on this map are based on the best data available at the time of publication. Because changes due to annexations or de-annexations may have occurred after this map was published, map users should contact appropriate community officials to verify current corporate limit locations.

Please refer to the separately printed **Map Index** for an overview map of the county showing the layout of map panels; community map repository addresses; and a Listing of Communities table containing National Flood Insurance Program dates for each community as well as a listing of the panels on which each community is located.

For information on available products associated with this FIRM visit the **Map Service Center (MSC)** website at <http://msc.fema.gov>. Available products may include previously issued Letters of Map Change, a Flood Insurance Study Report, and/or digital versions of this map. Many of these products can be ordered or obtained directly from the MSC website.

If you have **questions about this map**, how to order products, or the National Flood Insurance Program in general, please call the **FEMA Map Information eXchange (FMIX)** at 1-877-FEMA-MAP (1-877-336-2627) or visit the FEMA website at <http://www.fema.gov/business/nfp>.

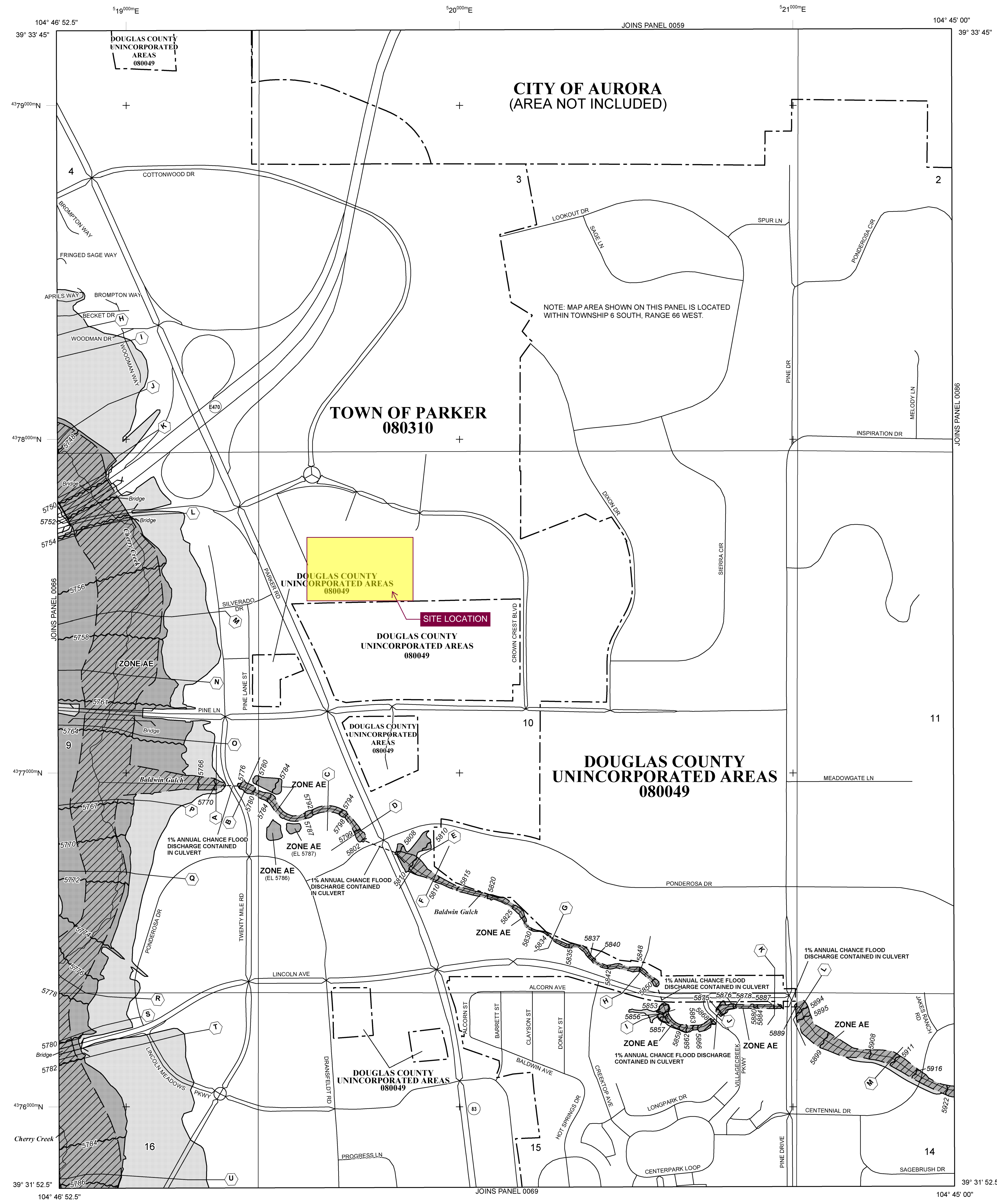

LEGEND

SPECIAL FLOOD HAZARD AREAS (SFHAs) SUBJECT TO INUNDATION BY THE 1% ANNUAL CHANCE FLOOD
The 1% annual chance flood (100-year flood), also known as the base flood, is the flood that has a 1% chance of being equaled or exceeded in any given year. The Special Flood Hazard Area is the area subject to flooding by the 1% annual chance flood. Areas of Special Flood Hazard include Zones A, AE, AH, AO, AR, A99, V, and VE. The Base Flood Elevation is the water-surface elevation of the 1% annual chance flood.

- ZONE A** No Base Flood Elevations determined.
- ZONE AE** Base Flood Elevations determined.
- ZONE AH** Flood depths of 1 to 3 feet (usually areas of ponding); Base Flood Elevations determined.
- ZONE AO** Flood depths of 1 to 3 feet (usually sheet flow on sloping terrain); average depths determined. For areas of alluvial fan flooding, velocities also determined.
- ZONE AR** Special Flood Hazard Areas formerly protected from the 1% annual chance flood by a flood control system that was subsequently derelict. Zone AR indicates that the former flood control system is being restored to provide protection from the 1% annual chance or greater flood.
- ZONE A99** Area to be protected from 1% annual chance flood by a Federal flood protection system under construction; no Base Flood Elevations determined.
- ZONE V** Coastal flood zone with velocity hazard (wave action); no Base Flood Elevations determined.
- ZONE VE** Coastal flood zone with velocity hazard (wave action); Base Flood Elevations determined.

FLOODWAY AREAS IN ZONE AE
The floodway is the channel of a stream plus any adjacent floodplain areas that must be kept free of encroachment so that the 1% annual chance flood can be carried without substantial increases in flood heights.

OTHER FLOOD AREAS

- ZONE X** Areas of 0.2% annual chance flood; areas of 1% annual chance flood with average depths of less than 1 foot or with drainage areas less than 1 square mile; and areas protected by levees from 1% annual chance flood.
- OTHER AREAS**
- ZONE X** Areas determined to be outside the 0.2% annual chance floodplain.
- ZONE D** Areas in which flood hazards are undetermined, but possible.

COASTAL BARRIER RESOURCES SYSTEM (CBRS) AREAS

OTHERWISE PROTECTED AREAS (OPAs)
CBRS areas and OPAs are normally located within or adjacent to Special Flood Hazard Areas.

- 1% Annual Chance Floodplain Boundary
- 0.2% Annual Chance Floodplain Boundary
- Floodway boundary
- Zone D boundary
- CBRS and OPA boundary
- Boundary dividing Special Flood Hazard Area Zones and boundary dividing Special Flood Hazard Areas of different Base Flood Elevations, flood depths, or flood velocities.
- Base Flood Elevation line and value; elevation in feet* (EL 987)
- Base Flood Elevation value where uniform within zone; elevation in feet*

*Referenced to the North American Vertical Datum of 1988

- Cross section line
- Transect line
- Geographic coordinates referenced to the North American Datum of 1983 (NAD 83) Western Hemisphere
- 1000-meter Universal Transverse Mercator grid values, zone 13
- Bench mark (see explanation in Notes to Users section of this FIRM panel)
- River Mile

MAP REPOSITORIES
Refer to Map Repositories list on Map Index

EFFECTIVE DATE OF COUNTYWIDE FLOOD INSURANCE RATE MAP
SEPTEMBER 30, 2005

EFFECTIVE DATE(S) OF REVISION(S) TO THIS PANEL
MARCH 16, 2016: to update corporate limits, to change base flood elevations, to add base flood elevations, to add special flood hazard areas, to update map format, to add roads and road names, to reflect updated topographic information, to incorporate previously issued letters of map revision

For community map revision history prior to countywide mapping, refer to the Community Map History table located in the Flood Insurance Study report for this jurisdiction.

To determine if flood insurance is available in this community, contact your insurance agent or call the National Flood Insurance Program at 1-800-638-6620.

MAP SCALE 1" = 500'

250 0 500 1000 FEET
150 0 150 300 METERS

NATIONAL FLOOD INSURANCE PROGRAM

PANEL 0067G

FIRM FLOOD INSURANCE RATE MAP DOUGLAS COUNTY, COLORADO AND INCORPORATED AREAS

PANEL 67 OF 495
(SEE MAP INDEX FOR FIRM PANEL LAYOUT)

CONTAINS:

COMMUNITY	NUMBER	PANEL	SUFFIX
DOUGLAS COUNTY	080049	0067	G
PARKER, TOWN OF	080310	0067	G

Notice to User: The **Map Number** shown below should be used when placing map orders; the **Community Number** shown above should be used on insurance applications for the subject community.

MAP NUMBER 08035C0067G
MAP REVISED MARCH 16, 2016
Federal Emergency Management Agency



United States
Department of
Agriculture

NRCS

Natural
Resources
Conservation
Service

A product of the National
Cooperative Soil Survey,
a joint effort of the United
States Department of
Agriculture and other
Federal agencies, State
agencies including the
Agricultural Experiment
Stations, and local
participants

Custom Soil Resource Report for Castle Rock Area, Colorado

AHP Web Soil Survey

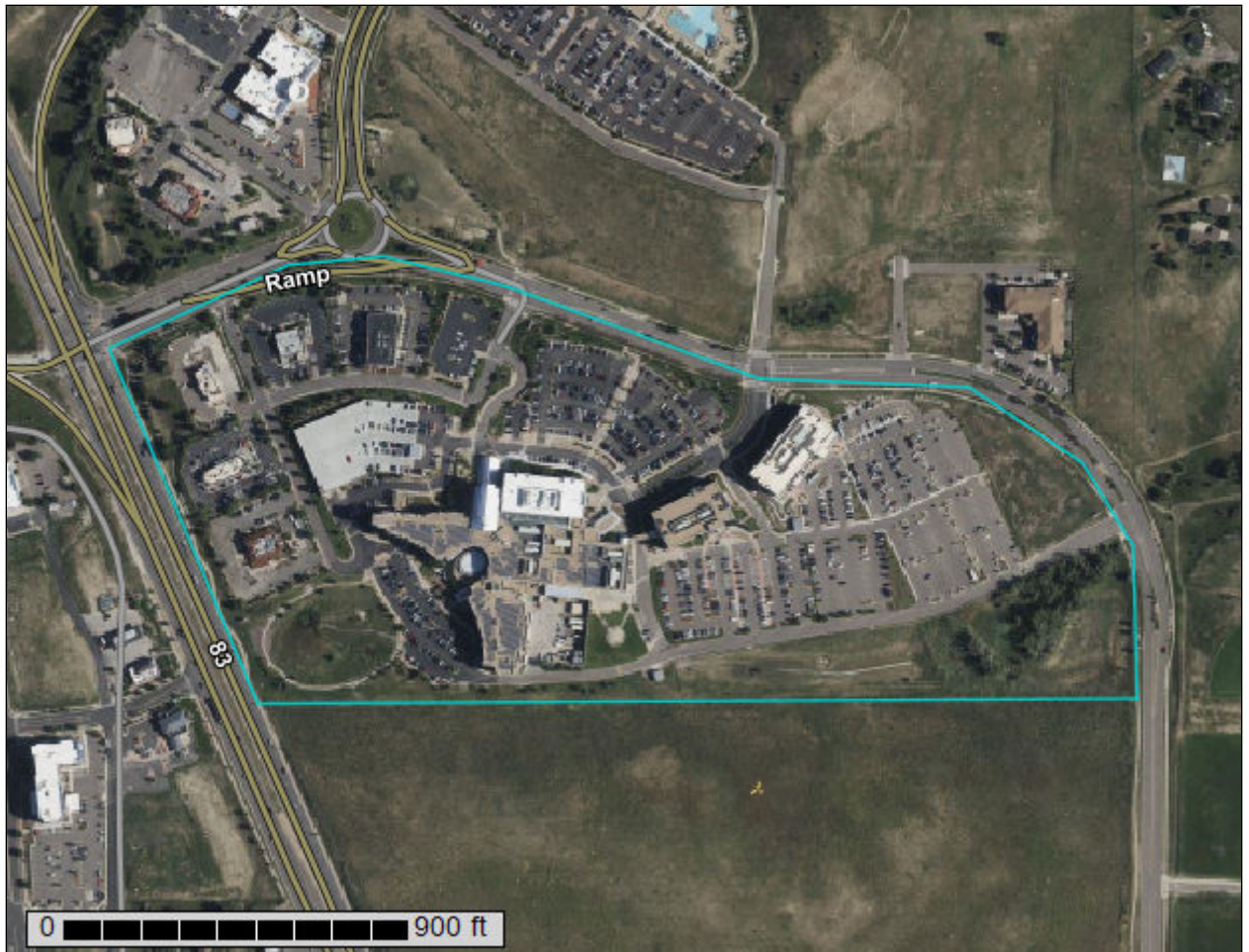

Preface

Soil surveys contain information that affects land use planning in survey areas. They highlight soil limitations that affect various land uses and provide information about the properties of the soils in the survey areas. Soil surveys are designed for many different users, including farmers, ranchers, foresters, agronomists, urban planners, community officials, engineers, developers, builders, and home buyers. Also, conservationists, teachers, students, and specialists in recreation, waste disposal, and pollution control can use the surveys to help them understand, protect, or enhance the environment.

Various land use regulations of Federal, State, and local governments may impose special restrictions on land use or land treatment. Soil surveys identify soil properties that are used in making various land use or land treatment decisions. The information is intended to help the land users identify and reduce the effects of soil limitations on various land uses. The landowner or user is responsible for identifying and complying with existing laws and regulations.

Although soil survey information can be used for general farm, local, and wider area planning, onsite investigation is needed to supplement this information in some cases. Examples include soil quality assessments (<http://www.nrcs.usda.gov/wps/portal/nrcs/main/soils/health/>) and certain conservation and engineering applications. For more detailed information, contact your local USDA Service Center (<https://offices.sc.egov.usda.gov/locator/app?agency=nrcs>) or your NRCS State Soil Scientist (http://www.nrcs.usda.gov/wps/portal/nrcs/detail/soils/contactus/?cid=nrcs142p2_053951).

Great differences in soil properties can occur within short distances. Some soils are seasonally wet or subject to flooding. Some are too unstable to be used as a foundation for buildings or roads. Clayey or wet soils are poorly suited to use as septic tank absorption fields. A high water table makes a soil poorly suited to basements or underground installations.

The National Cooperative Soil Survey is a joint effort of the United States Department of Agriculture and other Federal agencies, State agencies including the Agricultural Experiment Stations, and local agencies. The Natural Resources Conservation Service (NRCS) has leadership for the Federal part of the National Cooperative Soil Survey.

Information about soils is updated periodically. Updated information is available through the NRCS Web Soil Survey, the site for official soil survey information.

The U.S. Department of Agriculture (USDA) prohibits discrimination in all its programs and activities on the basis of race, color, national origin, age, disability, and where applicable, sex, marital status, familial status, parental status, religion, sexual orientation, genetic information, political beliefs, reprisal, or because all or a part of an individual's income is derived from any public assistance program. (Not all prohibited bases apply to all programs.) Persons with disabilities who require

alternative means for communication of program information (Braille, large print, audiotape, etc.) should contact USDA's TARGET Center at (202) 720-2600 (voice and TDD). To file a complaint of discrimination, write to USDA, Director, Office of Civil Rights, 1400 Independence Avenue, S.W., Washington, D.C. 20250-9410 or call (800) 795-3272 (voice) or (202) 720-6382 (TDD). USDA is an equal opportunity provider and employer.

Contents

Preface	2
How Soil Surveys Are Made	5
Soil Map	8
Soil Map.....	9
Legend.....	10
Map Unit Legend.....	11
Map Unit Descriptions.....	11
Castle Rock Area, Colorado.....	13
BrD—Bresser sandy loam, cool, 5 to 9 percent slopes.....	13
BtE—Bresser-Truckton sandy loams, 5 to 25 percent slopes.....	14
RmE—Renohill-Buick complex, 5 to 25 percent slopes.....	16
Sa—Sampson loam.....	18
References	20

How Soil Surveys Are Made

Soil surveys are made to provide information about the soils and miscellaneous areas in a specific area. They include a description of the soils and miscellaneous areas and their location on the landscape and tables that show soil properties and limitations affecting various uses. Soil scientists observed the steepness, length, and shape of the slopes; the general pattern of drainage; the kinds of crops and native plants; and the kinds of bedrock. They observed and described many soil profiles. A soil profile is the sequence of natural layers, or horizons, in a soil. The profile extends from the surface down into the unconsolidated material in which the soil formed or from the surface down to bedrock. The unconsolidated material is devoid of roots and other living organisms and has not been changed by other biological activity.

Currently, soils are mapped according to the boundaries of major land resource areas (MLRAs). MLRAs are geographically associated land resource units that share common characteristics related to physiography, geology, climate, water resources, soils, biological resources, and land uses (USDA, 2006). Soil survey areas typically consist of parts of one or more MLRA.

The soils and miscellaneous areas in a survey area occur in an orderly pattern that is related to the geology, landforms, relief, climate, and natural vegetation of the area. Each kind of soil and miscellaneous area is associated with a particular kind of landform or with a segment of the landform. By observing the soils and miscellaneous areas in the survey area and relating their position to specific segments of the landform, a soil scientist develops a concept, or model, of how they were formed. Thus, during mapping, this model enables the soil scientist to predict with a considerable degree of accuracy the kind of soil or miscellaneous area at a specific location on the landscape.

Commonly, individual soils on the landscape merge into one another as their characteristics gradually change. To construct an accurate soil map, however, soil scientists must determine the boundaries between the soils. They can observe only a limited number of soil profiles. Nevertheless, these observations, supplemented by an understanding of the soil-vegetation-landscape relationship, are sufficient to verify predictions of the kinds of soil in an area and to determine the boundaries.

Soil scientists recorded the characteristics of the soil profiles that they studied. They noted soil color, texture, size and shape of soil aggregates, kind and amount of rock fragments, distribution of plant roots, reaction, and other features that enable them to identify soils. After describing the soils in the survey area and determining their properties, the soil scientists assigned the soils to taxonomic classes (units). Taxonomic classes are concepts. Each taxonomic class has a set of soil characteristics with precisely defined limits. The classes are used as a basis for comparison to classify soils systematically. Soil taxonomy, the system of taxonomic classification used in the United States, is based mainly on the kind and character of soil properties and the arrangement of horizons within the profile. After the soil

Custom Soil Resource Report

scientists classified and named the soils in the survey area, they compared the individual soils with similar soils in the same taxonomic class in other areas so that they could confirm data and assemble additional data based on experience and research.

The objective of soil mapping is not to delineate pure map unit components; the objective is to separate the landscape into landforms or landform segments that have similar use and management requirements. Each map unit is defined by a unique combination of soil components and/or miscellaneous areas in predictable proportions. Some components may be highly contrasting to the other components of the map unit. The presence of minor components in a map unit in no way diminishes the usefulness or accuracy of the data. The delineation of such landforms and landform segments on the map provides sufficient information for the development of resource plans. If intensive use of small areas is planned, onsite investigation is needed to define and locate the soils and miscellaneous areas.

Soil scientists make many field observations in the process of producing a soil map. The frequency of observation is dependent upon several factors, including scale of mapping, intensity of mapping, design of map units, complexity of the landscape, and experience of the soil scientist. Observations are made to test and refine the soil-landscape model and predictions and to verify the classification of the soils at specific locations. Once the soil-landscape model is refined, a significantly smaller number of measurements of individual soil properties are made and recorded. These measurements may include field measurements, such as those for color, depth to bedrock, and texture, and laboratory measurements, such as those for content of sand, silt, clay, salt, and other components. Properties of each soil typically vary from one point to another across the landscape.

Observations for map unit components are aggregated to develop ranges of characteristics for the components. The aggregated values are presented. Direct measurements do not exist for every property presented for every map unit component. Values for some properties are estimated from combinations of other properties.

While a soil survey is in progress, samples of some of the soils in the area generally are collected for laboratory analyses and for engineering tests. Soil scientists interpret the data from these analyses and tests as well as the field-observed characteristics and the soil properties to determine the expected behavior of the soils under different uses. Interpretations for all of the soils are field tested through observation of the soils in different uses and under different levels of management. Some interpretations are modified to fit local conditions, and some new interpretations are developed to meet local needs. Data are assembled from other sources, such as research information, production records, and field experience of specialists. For example, data on crop yields under defined levels of management are assembled from farm records and from field or plot experiments on the same kinds of soil.

Predictions about soil behavior are based not only on soil properties but also on such variables as climate and biological activity. Soil conditions are predictable over long periods of time, but they are not predictable from year to year. For example, soil scientists can predict with a fairly high degree of accuracy that a given soil will have a high water table within certain depths in most years, but they cannot predict that a high water table will always be at a specific level in the soil on a specific date.

After soil scientists located and identified the significant natural bodies of soil in the survey area, they drew the boundaries of these bodies on aerial photographs and

Custom Soil Resource Report

identified each as a specific map unit. Aerial photographs show trees, buildings, fields, roads, and rivers, all of which help in locating boundaries accurately.

Soil Map

The soil map section includes the soil map for the defined area of interest, a list of soil map units on the map and extent of each map unit, and cartographic symbols displayed on the map. Also presented are various metadata about data used to produce the map, and a description of each soil map unit.

Custom Soil Resource Report Soil Map



Soil Map may not be valid at this scale.

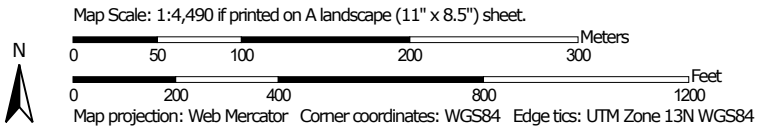

MAP LEGEND

Area of Interest (AOI)

 Area of Interest (AOI)



















Soils







 Soil Map Unit Polygons

 Soil Map Unit Lines

 Soil Map Unit Points

Special Point Features





-  Blowout
-  Borrow Pit
-  Clay Spot
-  Closed Depression
-  Gravel Pit
-  Gravelly Spot
-  Landfill
-  Lava Flow
-  Marsh or swamp
-  Mine or Quarry
-  Miscellaneous Water
-  Perennial Water
-  Rock Outcrop
-  Saline Spot
-  Sandy Spot
-  Severely Eroded Spot
-  Sinkhole
-  Slide or Slip
-  Sodic Spot

-  Spoil Area
-  Stony Spot
-  Very Stony Spot
-  Wet Spot
-  Other
-  Special Line Features

Water Features

 Streams and Canals

Transportation

-  Rails
-  Interstate Highways
-  US Routes
-  Major Roads
-  Local Roads

Background

 Aerial Photography

MAP INFORMATION

The soil surveys that comprise your AOI were mapped at 1:20,000.

Warning: Soil Map may not be valid at this scale.

Enlargement of maps beyond the scale of mapping can cause misunderstanding of the detail of mapping and accuracy of soil line placement. The maps do not show the small areas of contrasting soils that could have been shown at a more detailed scale.

Please rely on the bar scale on each map sheet for map measurements.

Source of Map: Natural Resources Conservation Service
 Web Soil Survey URL:
 Coordinate System: Web Mercator (EPSG:3857)

Maps from the Web Soil Survey are based on the Web Mercator projection, which preserves direction and shape but distorts distance and area. A projection that preserves area, such as the Albers equal-area conic projection, should be used if more accurate calculations of distance or area are required.

This product is generated from the USDA-NRCS certified data as of the version date(s) listed below.

Soil Survey Area: Castle Rock Area, Colorado
 Survey Area Data: Version 16, Aug 24, 2023

Soil map units are labeled (as space allows) for map scales 1:50,000 or larger.

Date(s) aerial images were photographed: Mar 1, 2023—Sep 1, 2023

The orthophoto or other base map on which the soil lines were compiled and digitized probably differs from the background imagery displayed on these maps. As a result, some minor shifting of map unit boundaries may be evident.

Map Unit Legend

Map Unit Symbol	Map Unit Name	Acres in AOI	Percent of AOI
BrD	Bresser sandy loam, cool, 5 to 9 percent slopes	6.6	12.3%
BtE	Bresser-Truckton sandy loams, 5 to 25 percent slopes	8.4	15.8%
RmE	Renohill-Buick complex, 5 to 25 percent slopes	38.3	71.8%
Sa	Sampson loam	0.0	0.1%
Totals for Area of Interest		53.4	100.0%

Map Unit Descriptions

The map units delineated on the detailed soil maps in a soil survey represent the soils or miscellaneous areas in the survey area. The map unit descriptions, along with the maps, can be used to determine the composition and properties of a unit.

A map unit delineation on a soil map represents an area dominated by one or more major kinds of soil or miscellaneous areas. A map unit is identified and named according to the taxonomic classification of the dominant soils. Within a taxonomic class there are precisely defined limits for the properties of the soils. On the landscape, however, the soils are natural phenomena, and they have the characteristic variability of all natural phenomena. Thus, the range of some observed properties may extend beyond the limits defined for a taxonomic class. Areas of soils of a single taxonomic class rarely, if ever, can be mapped without including areas of other taxonomic classes. Consequently, every map unit is made up of the soils or miscellaneous areas for which it is named and some minor components that belong to taxonomic classes other than those of the major soils.

Most minor soils have properties similar to those of the dominant soil or soils in the map unit, and thus they do not affect use and management. These are called noncontrasting, or similar, components. They may or may not be mentioned in a particular map unit description. Other minor components, however, have properties and behavioral characteristics divergent enough to affect use or to require different management. These are called contrasting, or dissimilar, components. They generally are in small areas and could not be mapped separately because of the scale used. Some small areas of strongly contrasting soils or miscellaneous areas are identified by a special symbol on the maps. If included in the database for a given area, the contrasting minor components are identified in the map unit descriptions along with some characteristics of each. A few areas of minor components may not have been observed, and consequently they are not mentioned in the descriptions, especially where the pattern was so complex that it was impractical to make enough observations to identify all the soils and miscellaneous areas on the landscape.

The presence of minor components in a map unit in no way diminishes the usefulness or accuracy of the data. The objective of mapping is not to delineate

Custom Soil Resource Report

pure taxonomic classes but rather to separate the landscape into landforms or landform segments that have similar use and management requirements. The delineation of such segments on the map provides sufficient information for the development of resource plans. If intensive use of small areas is planned, however, onsite investigation is needed to define and locate the soils and miscellaneous areas.

An identifying symbol precedes the map unit name in the map unit descriptions. Each description includes general facts about the unit and gives important soil properties and qualities.

Soils that have profiles that are almost alike make up a *soil series*. Except for differences in texture of the surface layer, all the soils of a series have major horizons that are similar in composition, thickness, and arrangement.

Soils of one series can differ in texture of the surface layer, slope, stoniness, salinity, degree of erosion, and other characteristics that affect their use. On the basis of such differences, a soil series is divided into *soil phases*. Most of the areas shown on the detailed soil maps are phases of soil series. The name of a soil phase commonly indicates a feature that affects use or management. For example, Alpha silt loam, 0 to 2 percent slopes, is a phase of the Alpha series.

Some map units are made up of two or more major soils or miscellaneous areas. These map units are complexes, associations, or undifferentiated groups.

A *complex* consists of two or more soils or miscellaneous areas in such an intricate pattern or in such small areas that they cannot be shown separately on the maps. The pattern and proportion of the soils or miscellaneous areas are somewhat similar in all areas. Alpha-Beta complex, 0 to 6 percent slopes, is an example.

An *association* is made up of two or more geographically associated soils or miscellaneous areas that are shown as one unit on the maps. Because of present or anticipated uses of the map units in the survey area, it was not considered practical or necessary to map the soils or miscellaneous areas separately. The pattern and relative proportion of the soils or miscellaneous areas are somewhat similar. Alpha-Beta association, 0 to 2 percent slopes, is an example.

An *undifferentiated group* is made up of two or more soils or miscellaneous areas that could be mapped individually but are mapped as one unit because similar interpretations can be made for use and management. The pattern and proportion of the soils or miscellaneous areas in a mapped area are not uniform. An area can be made up of only one of the major soils or miscellaneous areas, or it can be made up of all of them. Alpha and Beta soils, 0 to 2 percent slopes, is an example.

Some surveys include *miscellaneous areas*. Such areas have little or no soil material and support little or no vegetation. Rock outcrop is an example.

Castle Rock Area, Colorado

BrD—Bresser sandy loam, cool, 5 to 9 percent slopes

Map Unit Setting

National map unit symbol: 2tlpk
Elevation: 5,500 to 6,960 feet
Mean annual precipitation: 15 to 19 inches
Mean annual air temperature: 48 to 52 degrees F
Frost-free period: 100 to 130 days
Farmland classification: Not prime farmland

Map Unit Composition

Bresser, cool, and similar soils: 85 percent
Minor components: 15 percent
Estimates are based on observations, descriptions, and transects of the mapunit.

Description of Bresser, Cool

Setting

Landform: Interfluves
Landform position (two-dimensional): Shoulder, backslope
Landform position (three-dimensional): Interfluve
Down-slope shape: Linear
Across-slope shape: Linear
Parent material: Tertiary aged alluvium derived from arkose

Typical profile

Ap - 0 to 5 inches: sandy loam
Bt1 - 5 to 8 inches: sandy loam
Bt2 - 8 to 27 inches: sandy clay loam
Bt3 - 27 to 36 inches: sandy loam
C - 36 to 80 inches: loamy coarse sand

Properties and qualities

Slope: 5 to 9 percent
Depth to restrictive feature: More than 80 inches
Drainage class: Well drained
Runoff class: Medium
Capacity of the most limiting layer to transmit water (Ksat): Moderately high to high
(0.60 to 6.00 in/hr)
Depth to water table: More than 80 inches
Frequency of flooding: None
Frequency of ponding: None
Calcium carbonate, maximum content: 5 percent
Maximum salinity: Nonsaline to very slightly saline (0.1 to 2.0 mmhos/cm)
Available water supply, 0 to 60 inches: Low (about 5.4 inches)

Interpretive groups

Land capability classification (irrigated): 4e
Land capability classification (nonirrigated): 4e
Hydrologic Soil Group: B
Ecological site: R049XB210CO - Sandy Foothill
Hydric soil rating: No

Minor Components

Ascalon

Percent of map unit: 10 percent
Landform: Interfluves
Landform position (two-dimensional): Shoulder
Landform position (three-dimensional): Interfluve
Down-slope shape: Linear
Across-slope shape: Linear
Ecological site: R049XB210CO - Sandy Foothill
Hydric soil rating: No

Truckton

Percent of map unit: 5 percent
Landform: Interfluves
Landform position (two-dimensional): Backslope
Landform position (three-dimensional): Interfluve
Down-slope shape: Linear
Across-slope shape: Linear
Ecological site: R049XB210CO - Sandy Foothill
Hydric soil rating: No

BtE—Bresser-Truckton sandy loams, 5 to 25 percent slopes

Map Unit Setting

National map unit symbol: jqy9
Elevation: 5,500 to 6,600 feet
Mean annual precipitation: 15 to 19 inches
Mean annual air temperature: 47 to 52 degrees F
Frost-free period: 120 to 135 days
Farmland classification: Not prime farmland

Map Unit Composition

Bresser and similar soils: 50 percent
Truckton and similar soils: 35 percent
Minor components: 15 percent
Estimates are based on observations, descriptions, and transects of the mapunit.

Description of Bresser

Setting

Landform: Terraces
Landform position (three-dimensional): Riser, tread
Down-slope shape: Linear
Across-slope shape: Linear
Parent material: Sandy eolian deposits

Typical profile

H1 - 0 to 8 inches: sandy loam
H2 - 8 to 30 inches: sandy clay loam

Custom Soil Resource Report

H3 - 30 to 60 inches: loamy sand

Properties and qualities

Slope: 5 to 15 percent

Depth to restrictive feature: More than 80 inches

Drainage class: Well drained

Runoff class: Medium

Capacity of the most limiting layer to transmit water (Ksat): Moderately high to high (0.20 to 2.00 in/hr)

Depth to water table: More than 80 inches

Frequency of flooding: None

Frequency of ponding: None

Available water supply, 0 to 60 inches: Moderate (about 7.6 inches)

Interpretive groups

Land capability classification (irrigated): None specified

Land capability classification (nonirrigated): 6e

Hydrologic Soil Group: B

Ecological site: R049XB210CO - Sandy Foothill

Hydric soil rating: No

Description of Truckton

Setting

Landform: Terraces

Landform position (three-dimensional): Riser, tread

Down-slope shape: Linear

Across-slope shape: Linear

Parent material: Alluvium derived from arkosic sedimentary rock

Typical profile

H1 - 0 to 4 inches: sandy loam

H2 - 4 to 19 inches: sandy loam

H3 - 19 to 60 inches: sandy loam

Properties and qualities

Slope: 10 to 25 percent

Depth to restrictive feature: More than 80 inches

Drainage class: Well drained

Runoff class: Low

Capacity of the most limiting layer to transmit water (Ksat): High (2.00 to 6.00 in/hr)

Depth to water table: More than 80 inches

Frequency of flooding: None

Frequency of ponding: None

Available water supply, 0 to 60 inches: Low (about 6.0 inches)

Interpretive groups

Land capability classification (irrigated): None specified

Land capability classification (nonirrigated): 6e

Hydrologic Soil Group: A

Ecological site: R049XB210CO - Sandy Foothill

Hydric soil rating: No

Minor Components

Newlin

Percent of map unit: 5 percent

Custom Soil Resource Report

Hydric soil rating: No

Blakeland

Percent of map unit: 5 percent

Hydric soil rating: No

Stapleton

Percent of map unit: 4 percent

Hydric soil rating: No

Aquic haplustolls

Percent of map unit: 1 percent

Landform: Swales

Hydric soil rating: Yes

RmE—Renohill-Buick complex, 5 to 25 percent slopes

Map Unit Setting

National map unit symbol: jqzy

Elevation: 5,500 to 6,200 feet

Mean annual precipitation: 15 to 17 inches

Mean annual air temperature: 48 to 50 degrees F

Frost-free period: 120 to 135 days

Farmland classification: Not prime farmland

Map Unit Composition

Renohill and similar soils: 50 percent

Buick and similar soils: 30 percent

Minor components: 20 percent

Estimates are based on observations, descriptions, and transects of the mapunit.

Description of Renohill

Setting

Landform: Hills

Landform position (three-dimensional): Side slope, base slope

Down-slope shape: Linear

Across-slope shape: Linear

Parent material: Weathered, calcareous clayey shale

Typical profile

H1 - 0 to 3 inches: clay loam

H2 - 3 to 12 inches: clay loam

H3 - 12 to 24 inches: clay loam

H4 - 24 to 28 inches: unweathered bedrock

Properties and qualities

Slope: 5 to 25 percent

Depth to restrictive feature: 20 to 40 inches to paralithic bedrock

Drainage class: Well drained

Runoff class: High

Custom Soil Resource Report

Capacity of the most limiting layer to transmit water (Ksat): Moderately low to moderately high (0.06 to 0.20 in/hr)
Depth to water table: More than 80 inches
Frequency of flooding: None
Frequency of ponding: None
Calcium carbonate, maximum content: 15 percent
Maximum salinity: Nonsaline to very slightly saline (0.0 to 2.0 mmhos/cm)
Available water supply, 0 to 60 inches: Low (about 4.3 inches)

Interpretive groups

Land capability classification (irrigated): None specified
Land capability classification (nonirrigated): 6e
Hydrologic Soil Group: D
Ecological site: R049XC202CO - Loamy Foothill 14-19 PZ
Hydric soil rating: No

Description of Buick

Setting

Landform: Hills
Landform position (three-dimensional): Side slope, base slope
Down-slope shape: Linear
Across-slope shape: Linear
Parent material: Eolian deposits over silty alluvium

Typical profile

H1 - 0 to 4 inches: loam
H2 - 4 to 15 inches: silty clay loam
H3 - 15 to 22 inches: loam
H4 - 22 to 60 inches: sandy clay loam

Properties and qualities

Slope: 5 to 8 percent
Depth to restrictive feature: More than 80 inches
Drainage class: Well drained
Runoff class: Medium
Capacity of the most limiting layer to transmit water (Ksat): Moderately high (0.20 to 0.60 in/hr)
Depth to water table: More than 80 inches
Frequency of flooding: None
Frequency of ponding: None
Calcium carbonate, maximum content: 10 percent
Maximum salinity: Nonsaline to very slightly saline (0.0 to 2.0 mmhos/cm)
Available water supply, 0 to 60 inches: High (about 9.9 inches)

Interpretive groups

Land capability classification (irrigated): None specified
Land capability classification (nonirrigated): 6e
Hydrologic Soil Group: C
Ecological site: R049XC202CO - Loamy Foothill 14-19 PZ
Hydric soil rating: No

Minor Components

Manzanola

Percent of map unit: 6 percent
Hydric soil rating: No

Satanta

Percent of map unit: 6 percent
Hydric soil rating: No

Fondis

Percent of map unit: 6 percent
Hydric soil rating: No

Aquic haplustolls

Percent of map unit: 2 percent
Landform: Swales
Hydric soil rating: Yes

Sa—Sampson loam

Map Unit Setting

National map unit symbol: jr02
Elevation: 5,500 to 6,600 feet
Mean annual precipitation: 15 to 19 inches
Mean annual air temperature: 48 to 50 degrees F
Frost-free period: 120 to 135 days
Farmland classification: Farmland of statewide importance

Map Unit Composition

Sampson and similar soils: 80 percent
Minor components: 20 percent
Estimates are based on observations, descriptions, and transects of the mapunit.

Description of Sampson

Setting

Landform: Stream terraces on drainageways
Landform position (three-dimensional): Tread
Down-slope shape: Linear
Across-slope shape: Linear
Parent material: Weathered alluvium derived from arkose

Typical profile

H1 - 0 to 9 inches: loam
H2 - 9 to 28 inches: clay loam
H3 - 28 to 38 inches: loam
H4 - 38 to 60 inches: silt loam

Properties and qualities

Slope: 1 to 4 percent
Depth to restrictive feature: More than 80 inches
Drainage class: Well drained
Runoff class: Low
Capacity of the most limiting layer to transmit water (Ksat): Moderately high to high
(0.60 to 2.00 in/hr)

Custom Soil Resource Report

Depth to water table: More than 80 inches
Frequency of flooding: None
Frequency of ponding: None
Calcium carbonate, maximum content: 15 percent
Maximum salinity: Nonsaline to very slightly saline (0.0 to 2.0 mmhos/cm)
Available water supply, 0 to 60 inches: High (about 9.5 inches)

Interpretive groups

Land capability classification (irrigated): 3e
Land capability classification (nonirrigated): 3c
Hydrologic Soil Group: B
Ecological site: R049XC202CO - Loamy Foothill 14-19 PZ
Hydric soil rating: No

Minor Components

Englewood

Percent of map unit: 8 percent
Hydric soil rating: No

Bresser

Percent of map unit: 7 percent
Hydric soil rating: No

Loamy alluvial land

Percent of map unit: 4 percent
Hydric soil rating: No

Aquic haplustolls

Percent of map unit: 1 percent
Landform: Swales
Hydric soil rating: Yes