



March 18, 2025

Community Development Department  
Town Hall  
20120 East Main Street  
Parker, CO 80138  
Phone: (303) 841-2332

**Subject: SP24-128 • Black Rock Coffee • S. Parker Rd. & Stroh Rd. • Parker Pointe F1 AMD 1 L4A – Drive Through Coffee Shop • First Referral • review Comments 02: Response Letter**

To whom it may concern:

The following are responses to comments received from Case Planner, Julia Duncan, with the Town of Parker Planning Department, dated February 4th, 2025, regarding the submittal of a land use application with the Town of Parker.

**Code Reference:** 2021 International Fire Code, 2021 International Building Code, 2023 NEC

**Fire Life Safety Comments**

Randy Capra, [rcapra@parkeronline.org](mailto:rcapra@parkeronline.org)  
303.805.3163

**UNRESOLVED ISSUES/COMMENTS**

*The items noted below with a comment number (1, 2 etc.) are items that need to be corrected to show compliance with the applicable codes. Please provide a written response to this letter indicating where the corrections are made on the plans (cloud the plans as applicable and address all comments). This will speed up the second review process.*

**Fire Life Safety Comments**

Randy Capra

1. The applicant shall provide NO PARKING – FIRE LANE signage for any portion of the access where the 24-foot clear width requirement cannot be met.

Note - The Town of Parker requires that fire apparatus access roads meet the clear-width and weight-bearing standards of the jurisdiction in which the project is located. Roadways shall be designed to support the imposed weight of fire apparatus, 30-ton, two axle and 40-ton, three axle vehicles. An unimpeded clear width of 24-feet shall be always maintained. As such, any location where parked vehicles would obstruct this clear width requirement will require “NO

PARKING – FIRE LANE” signage. *This signage shall be red on white. Design criteria have been provided at the end of this document; ensure compliance when resubmitting.*

- This 24’ width requirement is always maintained, with drive aisles (excluding drive thru lanes) ranging from 24’ to 31’. As a result, no “NO PARKING – FIRE LANE” signage is required.
2. The applicant shall be aware that **no vertical construction on this site will be allowed until such time that curb gutter and first lift of asphalt are installed**; a site inspection will be required to ensure that this requirement is made prior to allowing vertical construction to commence.
    - Noted.
  3. The applicant shall be aware that the access road hydrant distribution was not planned to address the suppression needs for all commercial properties within this subdivision; this site requires the addition of one hydrant (to be located at the s/e corner island of the building... as required per NFPA 24 Section 7.2.3. The hydrant shall be located within 40 feet of the building to be served. A fire hydrant shall be provided and located in the northeast island (see below) and address this issue when resubmitting.

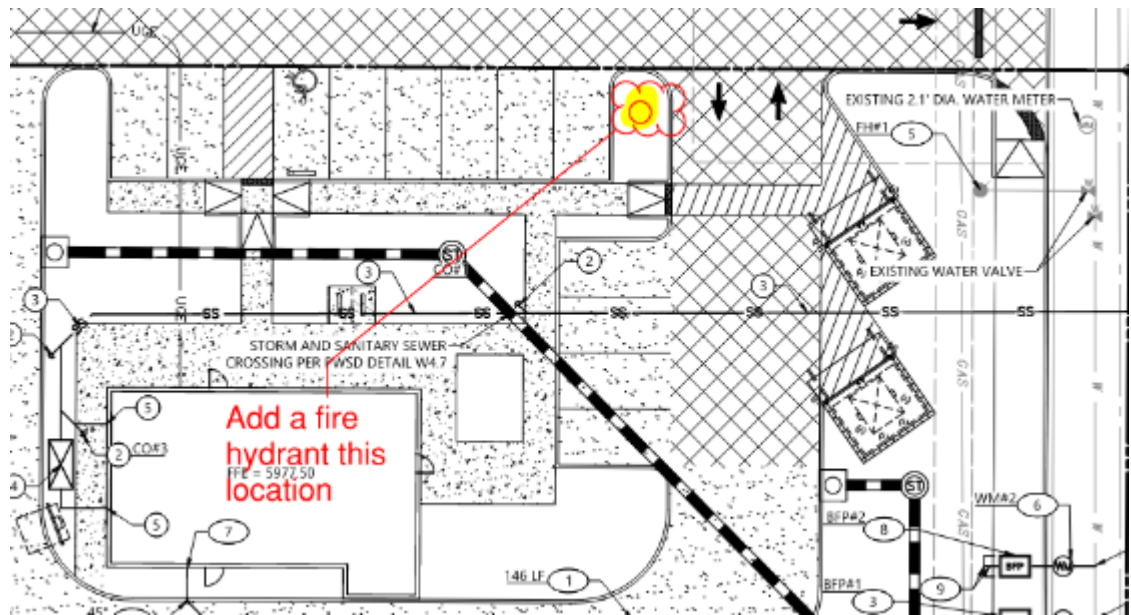

- a.
  - This fire hydrant and associated lines/valves have been added to both the original sheet set and the PWSD sheet set.

4. Utility drawings shall be provided with the Fire Life Safety signature block; this block shall be located on BOTH the cover sheet and the overall utility sheet. The required signature block is provided at the end of this document. Address this issue when resubmitting.

- The Fire Life Safety block has been added to both the Cover and Utility sheet.

5. Per the requirements of the 2021 IFC Section 503.1.1, approved fire apparatus access roads shall be provided to for every facility such that the requirements of this section extend to within 150 feet of all facility and all portions of all exterior walls of the first story of the building as measured

by an “approved route”. If this cannot be achieved, the fire code official is allowed to increase that distance so long as the building is fully sprinklered per 903 of the 2021 IFC. While it appears that the applicant may be able to meet the requirements of the code, the applicant shall prepare and provide an exhibit that “proves that the access can be met. Please note, hose does not bend at 90 degrees and the applicant’s exhibit shall mimic the exhibit provided in the 2021 IFC Handbook. To aid the applicant with what this looks like, please see the following and address this issue when resubmitting (measurement shall be taken centerline of the access road on the north side of the lot.

**Commentary Figure 503.1.1(2) FIRE DEPARTMENT ACCESS ON TWO SIDE**

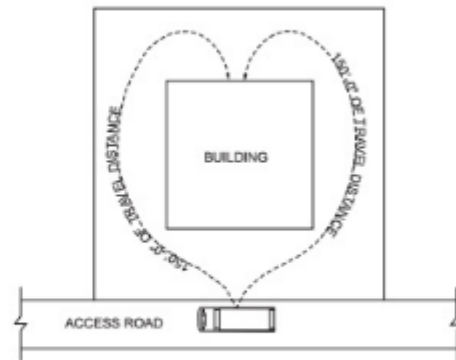

For SI: 1 foot = 304.8 mm.

**Commentary Figure 503.1.1(3) SMALL BUILDING ACCESS**

- a. ➤ This Fire Hose Proximity Exhibit has been included with this resubmittal.
- 6. In the event that the building needs to be sprinklered, the riser room shall be located in an accessible location (northeast corner of the building) and shall meet the following requirements:

The riser room shall be sized to accommodate the following:

- a. *The underground fire line is not allowed to have domestic tapped off of it*
- b. *The sprinkler riser is allowed to enter no further than 24-inches into the building (and any less than 12-inches into the building).*
- c. *A three-foot clearance shall be provided in front of the riser (with 18" of clearance on either side of the riser).*
- d. *The fire alarm control panel (FACP) is required to be located on an interior wall.*
- e. *A three-foot clearance is required in front of the FACP.*
- f. *Exterior access is required to be provided into the riser room; this access shall be approved.*
- g. *Access into the building shall be provided through the riser room or immediately adjacent to the riser room.*
- h. *While domestic water can be located in the riser room, the domestic cannot be located in any way that conflicts with the access requirements for both the FACP and the sprinkler riser.*
- i. *A sidewalk is required to the riser room and a 5 x 5 pad is required in front of the FDC.*

The applicant shall **provide a floor plan of how the riser room is to be laid out** to avoid conflicts with the site plan once the building review submittal has been made; this project will not be approved without this requirement having been met and approved.

➤ We should not need a riser room as the building does not need to be sprinkled at this time.

7. The applicant had not provided the required auto turn for the analysis, when resubmitting, provide an auto turn analysis for all areas shown below when resubmitting (note – failure to provide the analysis in all areas will result in delaying approval for the project).

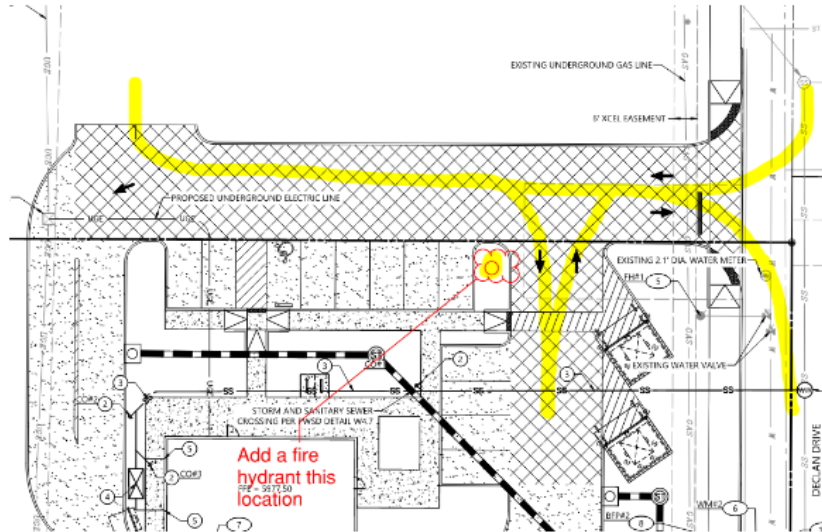

a.

➤ An auto turn exhibit has been included with this resubmittal.

8. The applicant shall work with Douglas County Planning and Zoning to determine the address for this project; the address is required to be obtained prior to submitting for a building permit as the address is required on all sheets of the submittal package. Address this issue when resubmitting.

➤ The address (13135 Declan Drive) has been included on all sheets.

9. The applicant shall work with Engineering to address having the utility documents signed once Planning has approved the project. Alex Mestdagh shall be your contact person when addressing this issue.

➤ Noted, we are in communication with PWSD regarding signatures on those documents.

### **General Comments (As Applicable)**

1. All engineering documents submitted to the Town of Parker shall bear the wet signature and seal of the engineer or architect in responsible charge of the design.

➤ Noted.

2. Water distribution and site access components shall be installed and in service prior to the construction of any portion of the structure, except by special permit issued by the Fire District.

➤ Noted.

### **Underground fire lines (as applicable)**

When thrust blocks are used as part of the pipe restraint system, submitted plans for permit shall provide detailed documentation that the thrust blocks satisfy all requirements of 19 NFPA 24: 10.8.2,

including specific thrust block dimensions and mathematical calculations for block dimensions per guidelines provided in Annex A.10.8.2.

➤ Acknowledged

### FIRE ACCESS ROAD DESIGN CRITERIA

**VEHICLE SPECIFICATIONS** are provided for the largest apparatus in use by South Metro Fire Rescue. Fire Apparatus Access Roads shall be capable of accommodating this apparatus.

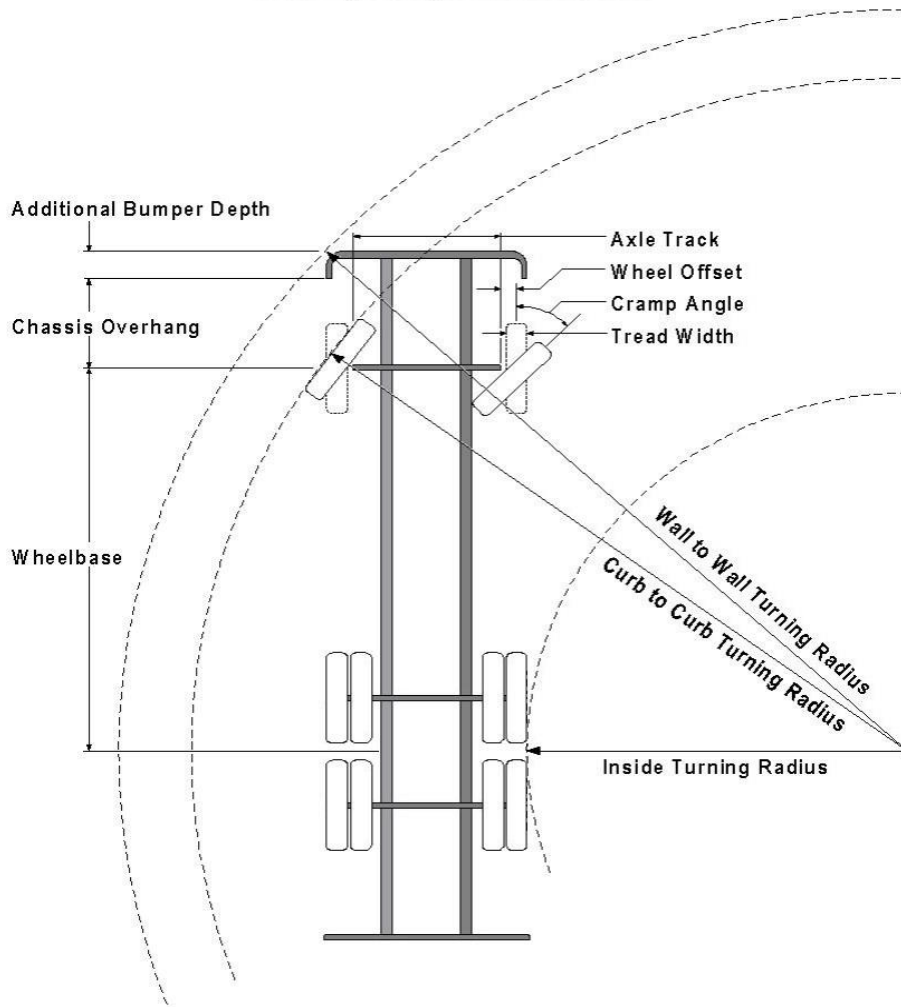
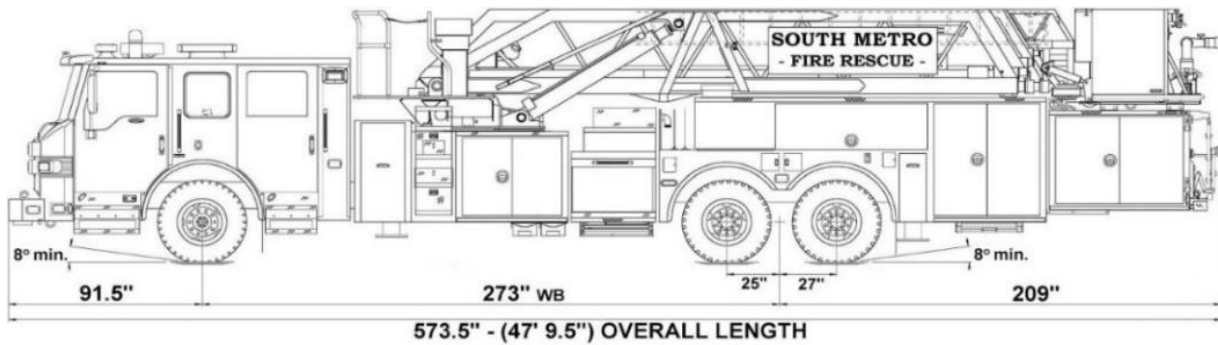

### **Vehicle Specifications**

Length: 47' 9.5"

Width: 8' 5" – (10'-1" mirror to mirror)

Height: 10'9"

Wheelbase: 273 in.

Design Load: 80,000 pounds

Inside Cramp Angle: 40°

Axle Track: 83°

Wheel Offset: 5.3"

Tread Width: 13.5"

### **Turning Radii:**

Inside Turn: 26 ft. 1 in.

Curb to Curb: 41 ft. 11 in.

Wall to Wall: 46 ft. 8 in.

Where objects are present adjacent to the fire apparatus access road, particularly on turns and turn arounds which require backing, a reasonable safety margin shall be provided to prevent potential damage to the property and to the fire apparatus.

PRIVATE ROADS that provide access to more than two dwellings or one or more commercial buildings shall be constructed to meet the roadway standards approved by the South Metro Fire Rescue Authority for fire apparatus access. Private roads that do not meet the roadway standard may be accepted provided that alternative methods and materials are incorporated into the subdivision that addresses the fire and life safety of the citizens.

### **Underground Fire Line - Submittal Requirements**

Reference: 2019 NFPA 24 Installation of Private Fire Service Mains and Their Appurtenances

A separate permit is required and will be issued pending review of a detailed submittal which must include the following: [21 IFC 901.2]

➤ Acknowledged

4.1.1 Working plans shall be submitted for approval to the authority having jurisdiction before any equipment is installed or replaced.

➤ Acknowledged

4.1.2 Deviation from approved plans shall require permission of the authority having jurisdiction.

➤ **Acknowledged**

4.1.3 Working plans shall be drawn to an indicated scale on sheets of uniform size, with a plan of each floor as

applicable, and shall include the following items that pertain to the design of the system:

- (1) Name of owner
- (2) Location, including street address
- (3) Point of compass
- (4) A graphic representation of the scale used on all plans
- (5) Name and address of contractor
- (6) Size and location of all water supplies
- (7) The following items that pertain to private fire service mains:
  - (a) Size
  - (b) Length
  - (c) Location
  - (d) Material (ductile-iron, PVC., etc.)
  - (e) Point of connection to city main
  - (f) Sizes, types, and locations of valves, depth at which the top of the pipe is laid below grade
  - (g) Method of restraint (Meg-a-Lug or similar)

➤ **Acknowledged**

4.1.4 The working plan submittal shall include the manufacturer's installation instructions for any specially listed equipment, including descriptions, applications, and limitations for any devices, piping, or fittings. Submittals must include installation specifications for thrust blocks, corrosion protection, restraint system, bedding, detail of pipe under the building up to, and including, the flange. When it is intended that a different contractor will extend the fire line from a stopping point outside the building, to the inside flange, a second submittal and permit is required.

➤ **Acknowledged**

**All tees, plugs, reducers, valves, and hydrant branches shall be restrained against movement by thrust blocks [10.8.2] or restrained joint systems [10.8.3]. When thrust blocks are used as part of the pipe restraint system, submitted plans shall provide detailed documentation that the thrust blocks satisfy all requirements of Section 10.8.2, including specific thrust block dimensions and mathematical calculations for block dimensions per guidelines provided in Annex A.10.8.2.**

Any individual or company who physically works on or installs any part of a fire suppression system, including underground supply lines, from public water lines to system risers and backflow preventers, **must** be registered with the Colorado Division of Fire Safety. [Dept of Public Safety, Division of Fire Safety, Fire Suppression Program 8 CCR 1507-11:3.1.2] Documentation of valid annual registration may be required with plan submittal.

The following website for the Colorado Division of Fire Safety will provide registration instructions.

<http://dfs.state.co.us/SuppAppsProclnsp.htm>

All submittals must display a wet stamp and original signature by a Colorado licensed professional engineer or NICET III, or higher, in fire suppression systems. [Dept. of Public Safety, Division of Fire Safety, Fire Suppression Program 8 CCR 1507

**FIRE CODE REVIEW BLOCK**

All fire hydrants shall be installed according to water utility standards. The number and locations of the fire hydrants as shown on the Overall Utility Plan are correct as specified by the Town of Parker, Community Development Department.

---

Fire Code Official or Designated Representative

Date

(NOTE - Underground Fire Line (UFL) submittal documents must meet the requirements of NFPA 24 when submitting for review.)

Please let us know if there are any questions on the above responses.

Thank you for your time and review,

Nicholas Salazar  
*Project Manager*

**ATWELL, LLC**

(972) 638-8860

*nsalazar@atwell.com*