



Development Review Division

Community Development Department: *Town Hall / 20120 East Mainstreet Parker, CO 80138* Phone: 303.841.2332 Fax: 303.841.3223

MEMORANDUM

TO: Khadeja Sarwar, Atwell, LLC
FROM: Cynthia Liston Thye, Planner I
DATE: 9/26/2025
SUBJECT: Parker Pointe, Black Rock Coffee, Site Plan
Review Comments 04

Listed below are the Planning Division's comments related to your land use application, which must be responded to. If you wish to discuss a comment, please contact your Case Planner. Upon resubmittal, please sign and return this memo. A follow-up meeting with the reviewing agencies can be scheduled to provide additional guidance by contacting the Case Planner.

TOWN OF PARKER PLANNING DEPARTMENT CASE PLANNER: Cynthia Liston Thye

EMAIL: cthye@parkerco.gov

PHONE: 303.805.3334

GENERAL PROJECT COMMENTS:

1. The Planning Division references certain sections of the Parker 2035 Master Plan, the Land Development Ordinance (LDO) and the Development Design Standards. Copies of these documents are available at:
[Parker 2035 Master Plan](#)
[Development Design Standards](#)
[Land Development Ordinance](#)
2. The Planning Division has made every effort to make this comment letter as comprehensive as possible. However, additional comments that have not been provided as part of this comment letter may be identified as part of future submittals, based on revisions to the project.
3. Please contact the referral agencies if you have questions regarding their review comment(s).
4. A redlined plan is included with this memorandum and is intended to supplement and clarify the review comments of this memorandum.
5. Final Plans submitted to the Building Department, Engineering Department and Parker Water and Sanitation District **must be exactly the same as the approved Site Plan set.**

6. The Town of Parker has implemented a naming convention for all applications. For all future documents that are uploaded to TRAKiT please ensure the submittal round is first, the name of the document is second and the name of the project is third. Example: "02" or "Second Submittal"

Site Plan and Project Details

1. Please see the attached redlines for all planning comments.

OUTSIDE REFERRAL AGENCY COMMENTS

I trust you have read the "Advisory Comments" from the various referral agencies. The following reviews in eTRAKiT have "Revisions Required:"

- Construction plans – environmental
- Construction plans – civil
- IREA (CORE)
- Parker Water and Sanitation
- Colorado Department of Transportation
- ONEOK (Magellan Pipeline)
- Site Plan - Planning

ONEOK (Magellan Pipeline) LANDSCAPING COMMENTS FROM 8/22/2025 EMAIL:

- We worked with Black Rock Coffee Bar and we had them remove trees that were within the Magellan easement and shift shrubs off of the pipeline. They have provided the attached updated plans meeting all of the requirements, and I sent them the below email indicating that Magellan has no objections to the landscaping encroachment. Due to minor landscaping work, we will not enter into a long form encroachment agreement, but will document in by a Short Form Encroachment Agreement in the field at the time of the work.



Project Details

Town of Parker

PROJECT NUMBER
SP24-128

Description: Parker Pointe F1 AMD 1 L4A - Drive Through Coffee Shop	Status: REVISIONS REQD 3+
Type: SITE PLAN	Status Date: 9/10/2025
Subtype: SITE PLAN - NON RESIDENTIAL	Applied: 12/9/2024
Address: 13135 DECLAN DR	Approved:
City, State, Zip: PARKER, CO 80134	Closed:
Project Manager: Cynthia Liston Thye	Expired:
Details: The applicant, Black Rock Coffee, is proposing a Site Plan for a coffee shop with a drive through. The site is located southeast of the intersection of Parker Road and Stroh Road.	

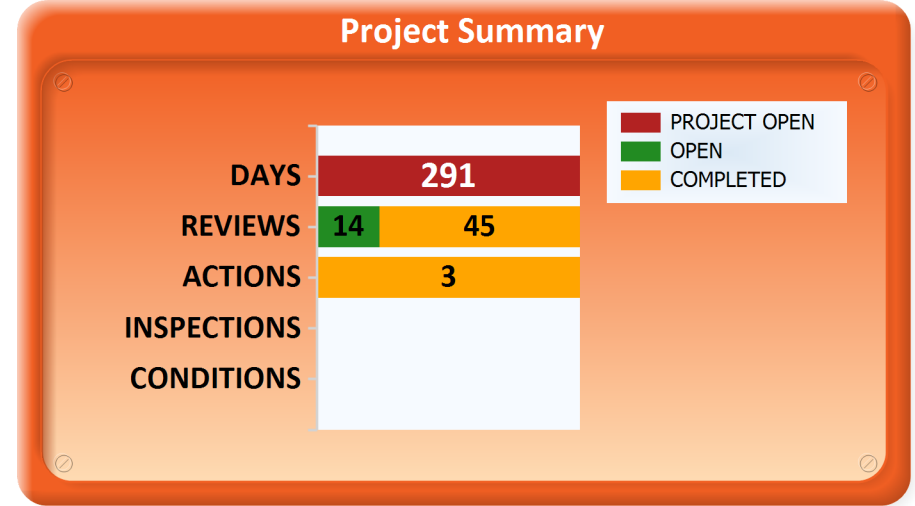

ADDITIONAL SITES

CHRONOLOGY

CHRONOLOGY TYPE	STAFF NAME	ACTION DATE	COMPLETION DATE	NOTES
EMAIL	Bryce Matthews	12/10/2024	12/10/2024	<p>Thanks for creating the above project in TRAKiT and uploading documents Please break up the Civil CD's, the PWSD CD's and the Site Plan with Landscape Plan into separate documents for review and upload the three documents. Once you have done so, please email me and I will assign the project to a planner.</p> <p>Feel free to reach out to me with any questions.</p> <p>Thanks</p> <p>Bryce</p>



PARKER
COLORADO



Project Details

Town of Parker

PROJECT NUMBER
SP24-128

EMAIL	Amber Wood Hicken	8/22/2025	8/22/2025	<p>From: Lucero, Clara A. <Clara.Lucero@oneok.com> Sent: Friday, August 22, 2025 11:33 AM To: Wood Hicken, Amber <ahicken@parkerco.gov> Subject: Parker Pointe Coffee Shop Landscape Review SP24-128</p> <p>Hi Amber,</p> <p>We worked with Black Rock Coffee Bar and we had them remove trees that were within the Magellan easement and shift shrubs off of the pipeline. They have provided the attached updated plans meeting all of the requirements, and I sent them the below email indicating that Magellan has no objections to the landscaping encroachment. Due to minor landscaping work, we will not enter into a long form encroachment agreement, but will document in by a Short Form Encroachment Agreement in the field at the time of the work.</p> <p>Please reach out if you need anything else from me.</p>
-------	-------------------	-----------	-----------	--



Project Details

Town of Parker

PROJECT NUMBER
SP24-128

EMAIL	Amber Wood Hicken	8/22/2025	8/22/2025	<p>From: Lucero, Clara A. <Clara.Lucero@oneok.com> Sent: Friday, August 22, 2025 1:00 PM To: Khadeja Sarwar <ksarwar@atwell.com>; Gallegos, Terry J. <Terry.Gallegos@oneok.com> Cc: Nicholas Salazar <nsalazar@atwell.com>; BRC-Atwell <BRC-Atwell@atwell.com>; Samantha Villegas <svillegas@atwell.com>; Catey Atchley <catchley@atwell.com>; Carlos Casas <ccasas@atwell.com>; Travis Bousquet <tbousquet@atwell.com> Subject: RE: (External) Black Rock Coffee - Parker Pointe - Revised Landscape Plan for Review SP24-128</p> <p style="text-align: center;">Hello Khadeja,</p> <p>This email is to clarify the below condition 'Landscaping and irrigation in Easement is subject to approval by the ONEOK Representative'. Magellan Pipeline Company, L.P., approves the landscaping plan that was provided to Magellan for evaluation. The landscaping company will follow plan requirements and will not modify the plans in the field.</p> <p style="text-align: center;">Thank you,</p>
-------	-------------------	-----------	-----------	--

CONDITIONS

CONTACTS

NAME TYPE	NAME	ADDRESS1	CITY	STATE	ZIP	PHONE	FAX	EMAIL
APPLICANT	Atwell LLC	9001 Airport Freeway Suite 660	North Richland Hills	TX	76180	(512)584-8669		nsalazar@atwell.com
DEVELOPER	Tony Pollotta	16307 NE Cameron Blvd	Portland	OR	97230	(512)584-8669		tony@br.coffee
ENGINEER	Nicholas Salazar	9001 Airport Freeway Suite 660	North Richland Hills	TX	76180	(512)584-8669		nsalazar@atwell.com
OWNER	Brad Willett	P.O. Box 867	Crested Butte	Co	81224	(512)584-8669		Brad@wildercolorado.com



Project Details

Town of Parker

PROJECT NUMBER
SP24-128

FINANCIAL INFORMATION

DESCRIPTION	ACCOUNT	QTY	AMOUNT	PAID	PAID DATE	RECEIPT #	CHECK #	METHOD	PAID BY	CLTD BY
GRADING/CBMP PLANS 0-5 ACRES	501-3400-4170	0	\$490.00	\$490.00	1/3/25	WEB70217	102096553 22	CREDIT	AEC8520	ECON
LANDSCAPING PLANS	101-3400-4130	0	\$270.00	\$270.00	1/3/25	WEB70217	102096553 22	CREDIT	AEC8520	ECON
UTILITY PLANS	101-3400-4130	0	\$340.00	\$340.00	1/3/25	WEB70217	102096553 22	CREDIT	AEC8520	ECON
Total Paid for ENGINEERING CONSTRUCTION PLAN REVIEW 2020 FEE SCHEDULE:			\$1,100.00	\$1,100.00						
SITE PLAN 0-5 ACRES	101-3400-4130	0	\$490.00	\$490.00	1/3/25	WEB70217	102096553 22	CREDIT	AEC8520	ECON
Total Paid for ENGINEERING LAND USE 2020 FEE SCHEDULE:			\$490.00	\$490.00						
DRAINAGE REPORT 0-5 ACRES	501-3400-4130	0	\$560.00	\$560.00	1/3/25	WEB70217	102096553 22	CREDIT	AEC8520	ECON
TRAFFIC CONFORMANCE LETTER	101-3400-4130	0	\$280.00	\$280.00	1/3/25	WEB70217	102096553 22	CREDIT	AEC8520	ECON
Total Paid for ENGINEERING STUDIES AND REPORTS 2020 FEE SCHEDULE:			\$840.00	\$840.00						
BUILDING SITE PLAN REVIEW	102-101-3400-4140	0	\$140.00	\$140.00	1/3/25	WEB70217	102096553 22	CREDIT	AEC8520	ECON
SITE PLAN - NONRESIDENTIAL 1-2 BUILDINGS	119-101-3400-4130	0	\$415.00	\$415.00	1/3/25	WEB70217	102096553 22	CREDIT	AEC8520	ECON
Total Paid for SITE PLAN 2020 FEE SCHEDULE:			\$555.00	\$555.00						
TOTALS:			\$2,985.00	\$2,985.00						

INSPECTIONS

INSPECTION TYPE	INSPECTOR	SCHEDULED DATE	COMPLETED DATE	RESULT	REMARKS	NOTES
-----------------	-----------	----------------	----------------	--------	---------	-------

REVIEW TYPE	REVIEWER	SENT DATE	DUE DATE	RETURNED DATE	STATUS	REMARKS	NOTES
BUILDING 10	Randy Capra	1/3/2025	2/3/2025	1/15/2025	ADVISORY COMMENTS	01 REVIEW 20	<p>Building and/or Fire Life Safety permit application will not be accepted/reviewed until the associated site plan is approved or otherwise discussed. All plans submitted for Building's review must meet the 2021 I-Codes, ICC A117.1-2017 for accessibility, the 2023 NEC and the referenced NFPA editions noted in the applicable codes (i.e., 2021 IFC references the 2019 edition of NFPA 72) if received by December 31, 2025. NFRC certificates, interior/exterior lighting along with the mechanical and envelope compliance path must be included with the original submittal. Note – for projects received after December 31, 2024, all projects will be required to meet the requirements of the 2023 NEC. All Fire Permit applications and inspections will be handled through the Parker Building Division. All land use applications and the associated Grading Permit must be approved/issued per Planning and Public Works prior to the Building Permit being approved/issued.</p> <p>Retaining walls greater than 4' from base of footing or bottom course requires separate building permits and plans must be stamped by qualified professional. Tiered/staggered/stepped back retaining walls all require permits no matter the height of individual wall.</p>
CDOT ACCESS 10	CDOT Referrals	7/21/2025	8/4/2025				
CDOT REGION 1 10	CDOT Referrals	7/21/2025	8/4/2025	9/10/2025	REVISIONS REQUIRED		See uploaded CDOT comments.
CDOT REGION 1 20	CDOT Referrals	9/26/2025	10/6/2025				

CENTURYLINK COMMUNICATIONS 10	CenturyLink	1/3/2025	2/3/2025			01 REVIEW 20	
CHERRY CREEK BASIN WATER QUALITY AUTHORITY 10	Val Endyk	1/3/2025	2/3/2025	1/6/2025	ADVISORY COMMENTS	See Notes	<p>The Cherry Creek Basin Water Quality Authority (Authority) acknowledges notification from the Town of Parker that the proposed development plans for SP24-128, Parker Pointe F1 AMD 1 L4A - Drive Through Coffee Shop have been or will be reviewed by the Town of Parker for compliance with the applicable Regulation 72 construction and post-construction requirements. Based on the Authority's current policy, the Authority will no longer routinely conduct a technical review and instead the Authority will defer to the Town of Parker's review and ultimate determination that the proposed development plans comply with Regulation 72.</p> <p>If a technical review of the proposed development plan is needed, please contact LandUseReferral@ccbwwqa.org. The review may include consultation with the Authority's Technical Manager to address specific questions or to conduct a more detailed Land Use Review, if warranted.</p>
COMCAST 10	Butch Buster	1/3/2025	2/3/2025			01 REVIEW 20	



PARKER
COLORADO



Project Details

Town of Parker

PROJECT NUMBER

SP24-128

COMPLETENESS REVIEW	Julia Duncan	12/18/2024	12/30/2024	12/30/2024	COMPLETED		<p>From: Duncan, Julia <jduncan@parkerco.gov> Sent: Monday, December 30, 2024 11:33 AM To: Nicholas Salazar <nsalazar@atwell.com> Cc: Khadeja Sarwar <ksarwar@atwell.com>; Catey Atchley <catchley@atwell.com>; Carlos Casas <ccasas@atwell.com>; Samantha Villegas <svillegas@atwell.com>; Sophia Kidd <skidd@atwell.com> Subject: Re: SP24-128 - Parker Pointe Coffee</p> <p style="text-align: center;">Good Morning Nick,</p> <p>I have deemed the submittal complete for submittal requirements. However, we will need fees paid prior to sending out on referral. I am waiting for Engineering staff to add those fees and will keep you posted. Can you please let me know if you will be paying with a credit card or by check?</p> <p style="text-align: center;">Sincerely,</p> <p style="text-align: center;">Julia</p>
---------------------	--------------	------------	------------	------------	-----------	--	---



PARKER
COLORADO



Project Details

Town of Parker

PROJECT NUMBER
SP24-128

CONST PLANS - ENVIRONMENTAL	Robert Seacat	8/26/2025	9/10/2025	9/3/2025	REVISIONS REQUIRED	See Engineering Memo and Comments	<p>SP24-128 Parker Point, Black Rock Coffee – 4th Environmental Review, 9-3-25</p> <p>Please note that a CBMP Cost Estimate will be required and reviewed with the Grading Permit after all CBMP comments have been addressed and the final site plan is near approval.</p> <p>GENERAL COMMENTS</p> <p>INITIAL CBMP PLAN SHEET</p> <ol style="list-style-type: none"> 1. Please show construction fence (not silt fence) along the south side of the VTC to ensure use of the entire 50-foot pad. 2. Please remove the Utility Easement Lines from the Initial Erosion Control Plan Sheet. <p>INTERIM CBMP PLAN SHEET</p> <ol style="list-style-type: none"> 3. Please show construction fence along the south side of the VTC to ensure use of the entire 50-foot pad.
CONST PLANS - ENVIRONMENTAL	Robert Seacat	9/26/2025	10/6/2025				

<p>CONST PLANS - ENVIRONMENTAL 10</p>	<p>Robert Seacat</p>	<p>7/8/2025</p>	<p>7/21/2025</p>	<p>7/21/2025</p>	<p>REVISIONS REQUIRED</p>	<p>See Engineering Memo and Comments</p>	<p>SP24-128 Parker Point, Black Rock Coffee – 3rd Environmental Review, 7-21-25</p> <p>Please note that a CBMP Cost Estimate will be required and reviewed with the Grading Permit after all CBMP comments have been addressed and the final site plan is near approval.</p> <p>GENERAL COMMENTS (All Erosion Control Plan Sheets)</p> <p>1. Please include within the plan set, immediately following the Final Erosion Control Plan Sheet, all 71 pages of the Town of Parker’s CBMP Legend, General Notes & CBMP Details (in Alphabetical Order). Keys/Symbols (1st) SHOWN TWICE, General Notes (2nd) IS MISSING. See link below for layout and use.</p> <p>2. Please add a callout/label on all properties adjacent to the project stating: “NO WORK SHALL OCCUR IN THIS AREA”. These areas must be shaded for easy identification.</p> <p>INITIAL CBMP PLANS</p> <p>3. Please show construction fence along the south side of the VTC to ensure use of the entire 50-foot pad.</p> <p>Links: 72-page layout of CBMP Legend, General Notes and Details Link: https://drive.google.com/file/d/1oE5TRyFktV-bdRygduwlqhwaf3eQJxzs/view?usp=drive_link</p>
---	----------------------	-----------------	------------------	------------------	---------------------------	--	--



							<p>SP24-128 Parker Point, Black Rock Coffee – 1st Environmental Review, 2-3-25</p> <p>Please note that a CBMP Cost Estimate will be required and reviewed with the Grading Permit after all CBMP comments have been addressed and the final site plan is near approval.</p> <p style="text-align: center;">GENERAL COMMENTS</p> <p>1. Please note: Civil Plans must include multiple Erosion Control Plan Sheets referencing the Initial, Interim and Final phases of the project. Initial Erosion Control Plan Sheet: Only show the Initial CBMPs (Silt Fence Perimeter Control, Construction Fence Perimeter Control, VTC, Staging Area, Portable Toilets, Concrete Washout, Inlet Protection, and existing stormwater utilities). Interim Erosion Control Plan Sheet: Show all CBMPs needed through the progression of the construction project. Final Erosion Control Plan Sheet: Show all permanent CBMPs that will remain in place till the native grasses are established.</p> <p>2. Please follow the Town of Parker Stormwater/Erosion Control Requirements using the Erosion Control - CBMP Plan Checklist. Link below.</p> <p>(These Notes Required on ALL EROSION CONTROL PLAN SHEETS, Initial, Interim and Final)</p> <p>3. Please add a general note stating – “THE VTC PAD FOR A CWA DOES NOT NEED TO CONFORM TO THE FORMAL VTC DETAIL”.</p> <p>4. Please add a general note stating – “THE TRUE</p>
--	--	--	--	--	--	--	--

<p>CONST PLANS - ENVIRONMENTAL 10</p>	<p>Robert Seacat</p>	<p>1/3/2025</p>	<p>2/3/2025</p>	<p>2/3/2025</p>	<p>REVISIONS REQUIRED</p>	<p>See Engineering Memo and Comments</p>	<p>LOCATION OF THE CWA MAY BE DETERMINED BY THE TOWN AND THE ECS".</p> <p>5. Please add a general note stating – “LOT PROTECTION (LP) IS REQUIRED ON RESIDENTIAL LOTS WHEN COMPLETION OF LANDSCAPING IS NOT POSSIBLE and PRIOR TO ISSUANCE OF A CERTIFICATE OF OCCUPANCY.”</p> <p>6. Please add a general note stating – “LOT PROTECTION (LP) IS REQUIRED ON COMMERCIAL LOTS WHEN COMPLETION OF LANDSCAPING IS NOT POSSIBLE and PRIOR TO ISSUANCE OF A TEMPORARY CERTIFICATE OF OCCUPANCY.”</p> <p>7. Please add a general note stating – “THE TRUE LOCATION OF THE PORTABLE TOILET PROTECTION (PTP) MAY BE DETERMINED BY THE TOWN AND THE ECS”.</p> <p>8. Please add a general note stating – “MASONRY WORK PROTECTION IS REQUIRED FOR CONSTRUCTION OF BUILDINGS”.</p> <p>9. Please add a general note stating – “ANY ONSITE BULK FUEL STORAGE REQUIRES A FIRE LIFE SAFETY PERMIT FROM THE TOWN OF PARKER PRIOR TO INSTALLATION”. Contact Randy Capra at 303-805-3136 or rcapra@parkeronline.org for FLS Permit questions.</p> <p>Links: 72-page layout of CBMP Legend, General Notes and Details Link: https://drive.google.com/file/d/1oESTRyFktV-bdRygduwlqhwaf3eQJxzs/view?usp=drive_link</p> <p>Stormwater/Storm Drainage and Environmental Criteria Manuel Microsoft Word - SDECM Draft 10-21-13 (parkerco.gov)</p>
---	----------------------	-----------------	-----------------	-----------------	---------------------------	--	--



Project Details

Town of Parker

PROJECT NUMBER
SP24-128

						<p>Roadway Design/Construction Criteria Manual Roadway-Design--Construction-Criteria-Manual (parkerco.gov)</p> <p>Erosion Control CBMP Checklist (See Appendix D) Microsoft Word - SDECM Draft 10-21-13 (parkerco.gov)</p>
						<p>SP24-128 Parker Point, Black Rock Coffee – 2nd Environmental Review, 4-1-25</p> <p>Please note that a CBMP Cost Estimate will be required and reviewed with the Grading Permit after all CBMP comments have been addressed and the final site plan is near approval.</p> <p>GENERAL COMMENTS (All Erosion Control Plan Sheets)</p> <ol style="list-style-type: none"> 1. Please follow the Town of Parker Stormwater/Erosion Control Requirements using the Erosion Control - CBMP Plan Checklist. Link below. 2. Please provide and use Parker’s complete Legend of Keys/Symbols to correspond to the Parker’s 31 CBMP Details on the Erosion Control plan sheets. 3. Please include within the plan set, immediately following the Final Erosion Control Plan Sheet, all 71 pages of the Town of Parker’s CBMP Legend, General Notes & CBMP Details (in Alphabetical Order). See link below for layout and use. 4. Initial Erosion Control Plan Sheet: Only show the Initial CBMPs, Silt Fence Perimeter Control, Construction Fence Perimeter Control, VTC, Staging Area, Portable Toilets, Concrete Washout, and existing stormwater utilities with Inlet



<p>CONST PLANS - ENVIRONMENTAL 15</p>	<p>Robert Seacat</p>	<p>3/19/2025</p>	<p>4/9/2025</p>	<p>4/2/2025</p>	<p>REVISIONS REQUIRED</p>	<p>See Engineering Memo and Comments</p>	<p>Protection outside of the site. Initial sheet should show the site as it currently exists, a dirt lot. Interim Erosion Control Plan Sheet: Show all CBMPs needed through the progression of the construction project. Interim sheet should show the parking lot/driveway and building layout with the proposed stormwater. Final Erosion Control Plan Sheet: Show all permanent CBMPs that will remain in place till the native grasses are established. Final sheet would show the layout of the completed site.</p> <p>5. Please add a callout/label on all properties adjacent to the project stating: "NO WORK SHALL OCCUR IN THIS AREA". These areas must be shaded for easy identification.</p> <p style="text-align: center;">INITIAL CBMP PLANS</p> <p>6. Initial Erosion Control Plan Sheet: Only show the Initial CBMPs, Silt Fence Perimeter Control, Construction Fence Perimeter Control, VTC, Staging Area, Portable Toilets, Concrete Washout, and existing stormwater utilities with Inlet Protection outside of the site. Initial sheet should show the site as it currently exists, a dirt lot. Silt Fence Perimeter Control is required for the entire site.</p> <p>7. Please show existing grading contours and provide arrows to indicate the direction of stormwater flow after removing all proposed construction diagrams (buildings and parking lot/sidewalks).</p> <p>8. Please show Inlet Protection on the existing inlet located to the south of the site on the Declan Drive.</p>
---	----------------------	------------------	-----------------	-----------------	---------------------------	--	---



--	--	--	--	--	--	--	--

INTERIM CBMP PLANS

- 9. Interim Erosion Control Plan Sheet: Show all CBMPs needed through the progression of the construction project. Interim sheet should show the parking lot/driveway and building layout with the proposed stormwater.
- 10. Please show Inlet Protection on the existing inlet located to the south of the site on the Declan Drive.
- 11. Please remove the roadway striping arrows from the plan sheet to avoid confusion with the stormwater flow arrows.
- 12. Sediment Control Log (SCL) is required at back of curb and back of sidewalk immediately after installation of asphalt in roadways and parking areas. This includes landscape islands and all pedestrian walks. Please provide and identify on the plans where needed. Note: if tree lawn/landscape areas are graded to final grade, Erosion Control Blanket (ECB) may be used to cover the entire tree lawn/landscape area instead of using SCL at back of sidewalk/curb.
- 13. Parker does not allow the use of sandbags, you must use SCL or SF.

FINAL CBMP PLANS

- 14. Final Erosion Control Plan Sheet: Show all permanent CBMPs that will remain in place till the native grasses are established. Final sheet would show the layout of the completed site identifying the native grass areas and the landscaped areas.

Links:
72-page layout of CBMP Legend, General Notes

							<p>and Details Link: https://drive.google.com/file/d/1oE5TRyFktV-bdRygduwlqhwaf3eQJxzs/view?usp=drive_link CBMP Details http://parkeronline.org/532/Construction-Best-Management-Practices Erosion Control CBMP Checklist (See Appendix D) Microsoft Word - SDECM Draft 10-21-13 (parkerco.gov)</p>
CONSTRUCTION PLANS - CIVIL	Charles Kudlauskas	8/26/2025	9/10/2025	9/3/2025	REVISIONS REQUIRED	See uploaded Memo. Minor Comments	
CONSTRUCTION PLANS - CIVIL	Charles Kudlauskas	9/26/2025	10/6/2025				
CONSTRUCTION PLANS - CIVIL 10	Charles Kudlauskas	7/8/2025	7/21/2025	7/21/2025	REVISIONS REQUIRED	See uploaded Memo.	Please address minor comments to the Construction Plans. See attached memo.
CONSTRUCTION PLANS - CIVIL 10	Charles Kudlauskas	1/3/2025	2/3/2025	2/4/2025	REVISIONS REQUIRED	See uploaded Memo and Redlines.	
CONSTRUCTION PLANS - CIVIL 15	Charles Kudlauskas	3/19/2025	4/9/2025	4/4/2025	REVISIONS REQUIRED	See uploaded Memo and Redlines.	
DOUGLAS COUNTY ASSESSORS OFFICE 10	Marian Woodward	1/3/2025	2/3/2025	2/3/2025	NO COMMENT	01 REVIEW 20	
DOUGLAS COUNTY ENGINEERING DIVISION 10	DC Referrals	1/3/2025	2/3/2025	1/6/2025	NOT APPLICABLE	01 REVIEW 20	N/A
DOUGLAS COUNTY PLANNING SERVICES DIVISION 10	DC Referrals	1/3/2025	2/3/2025	1/24/2025	ADVISORY COMMENTS	01 REVIEW 20	See the attached Referral Comment Report.
DOUGLAS COUNTY SCHOOL DISTRICT RE1 10	Shavon Caldwell	1/3/2025	2/3/2025			01 REVIEW 20	
DRAINAGE REPORT - CIVIL	Charles Kudlauskas	8/26/2025	9/10/2025	9/3/2025	COMPLETED		



Project Details

Town of Parker

PROJECT NUMBER
SP24-128

DRAINAGE REPORT - CIVIL 10	Charles Kudlauskas	7/8/2025	7/21/2025	7/21/2025	REVISIONS REQUIRED	See uploaded Memo.	Please address minor comments to the Drainage Report. See attached memo.
DRAINAGE REPORT - CIVIL 10	Charles Kudlauskas	1/3/2025	2/3/2025	2/4/2025	REVISIONS REQUIRED	See uploaded Memo.	
DRAINAGE REPORT - CIVIL 15	Charles Kudlauskas	3/19/2025	4/9/2025	4/4/2025	REVISIONS REQUIRED	See uploaded Memo and Redlines.	
ENGINEERING ADMINISTRATIVE	Tom Williams	12/9/2024					
FIRE LIFE SAFETY 10	Randy Capra	7/8/2025	7/21/2025	7/9/2025	APPROVED		
FIRE LIFE SAFETY 10	Randy Capra	1/3/2025	2/3/2025	1/15/2025	REVISIONS REQUIRED	See Notes	See response letter named "SP24-128 Parker Pointe F1 AMD 1 L4A - Drive Through Coffee Shop [1] Fire Life Safety Response Ltr 011525" and address all comments... as well as providing a written response to the letter provided.
FIRE LIFE SAFETY 15	Randy Capra	3/19/2025	4/9/2025	3/26/2025	REVISIONS REQUIRED	See Notes	There are issues that require attention; see response letter and address all issues when resubmitting.
FIRE LIFE SAFETY 15	Randy Capra	4/4/2025	4/25/2025	4/7/2025	REVISIONS REQUIRED	See response	
IREA 10	Brooks Kaufman	7/8/2025	7/21/2025	7/18/2025	DENIED	CORE & Town approval transformer and meter locations	Update site plan proposed relocate of transformer is not a transformer but a cubical (junction) and will be required to prior to grading permit. The applicant responses are not sufficient for CORE or the town to approve. Transformer and metering location will be required to be final on next review to meet CORE's and Town's requirements.

IREA 10	Brooks Kaufman	1/3/2025	2/3/2025	1/31/2025	REVISIONS REQUIRED	01 REVIEW 20	<p>The applicant will be required to provide the transformer and metering locations; meet CORE's clearance requirements and the Town of Parker requirements.</p> <p>CORE has existing cubical that will be required to be relocated prior to issuing grading permit. Grade may not change +/- 6 inches within CORE's existing 15-foot easement.</p> <p>CORE will require additional easement by separate document at electric design for electric facilities.</p> <p>The applicant will be required to provide parking lot lighting plan, parking lot lights may not encroach into utility easements or CORE easement.</p>
IREA 15	Brooks Kaufman	3/19/2025	4/9/2025	4/8/2025	DENIED	Provide transformer and Metering locations	<p>The applicant didn't address CORE's previous comments to provide the transformer and metering locations. The locations will be required to meet CORE's clearance requirements and the Town's approval.</p> <p>The applicant will be required to relocate CORE's existing facilities prior to the start of construction.</p>
IREA 20	Brooks Kaufman	8/26/2025	9/10/2025	9/10/2025	REVISIONS REQUIRED	Conditionally Approved	<p>The proposed location of the CORE transformer may work, but the depicted transformer size is incorrect. The applicant should assume a 10"x10" transformer size and revise the clearance from the 10"x10" size. Reminder the transformer may not open into a drive and will require a working clearance of 10" from back of curb in front of the transformer's doors.</p>
IREA 20	Brooks Kaufman	9/26/2025	10/6/2025				
LAND USE COMPLETENESS REVIEW	Alex Mestdagh	12/9/2024	12/23/2024	12/30/2024	COMPLETED		



Project Details

Town of Parker

PROJECT NUMBER
SP24-128

MAGELLAN PIPELINE 10	Clara Lucero	7/21/2025	8/4/2025				
PARKER WATER AND SANITATION DISTRICT 10	Robert Ramsey	7/8/2025	7/21/2025	7/21/2025	REVISIONS REQUIRED	see notes	Please note PWSD needs the following documents to complete this project. Signed PWSD plans from South Metro fire. Engineering review fees and Irrigation review fees. Tap fee invoice to be paid in full. PWSD original 20 foot Hydrant Easement agreement.
PARKER WATER AND SANITATION DISTRICT 10	Robert Ramsey	1/3/2025	2/3/2025	2/3/2025	REVISIONS REQUIRED	see notes	Please see red lined plans. Please provide fixture count worksheet. Please provide an Address for the building. Please provide irrigation and Landscape plans. Please feel free to reach out with any questions you may have.
PARKER WATER AND SANITATION DISTRICT 15	Robert Ramsey	3/19/2025	4/9/2025	4/9/2025	REVISIONS REQUIRED	see notes	Please see uploaded red lined plans, review letter, and 22 foot hydrant easement. Please feel free to reach out with any questions you may have.
PARKER WATER AND SANITATION DISTRICT 20	Robert Ramsey	8/26/2025	9/10/2025	9/8/2025	REVISIONS REQUIRED	see notes	Please note the Civil plan set needs to be reloaded unable to see set of plans. Please note all PWSD invoices must be paid in full.
PARKER WATER AND SANITATION DISTRICT 20	Drayton Sanderson	9/26/2025	10/6/2025				
PLAT - CIVIL 10	Charles Kudlauskas	1/3/2025	2/3/2025	2/4/2025	NOT APPLICABLE	01 REVIEW 20	
POLICE 10	Greg Epp	1/3/2025	2/3/2025			01 REVIEW 20	
PSCO RESIDENTIAL SUBDIVISIONS 10	Xcel Energy	1/3/2025	2/3/2025			01 REVIEW 20	



Project Details

Town of Parker

PROJECT NUMBER
SP24-128

PUBLIC SERVICE COMPANY OF COLORADO 10	Donna George	1/3/2025	2/3/2025	1/28/2025	COMPLETED	please see attached	please see attached
SITE PLAN - CIVIL 10	Charles Kudlauskas	7/21/2025	8/4/2025	7/21/2025	COMPLETED		
SITE PLAN - CIVIL 10	Charles Kudlauskas	1/3/2025	2/3/2025	1/31/2025	REVISIONS REQUIRED	See uploaded Memo.	
SITE PLAN - CIVIL 15	Charles Kudlauskas	3/19/2025	4/9/2025	4/4/2025	REVISIONS REQUIRED	See uploaded Memo and Redlines.	
SITE PLAN 10	Amber Wood Hicken	7/8/2025	7/21/2025	7/21/2025	REVISIONS REQUIRED		see planning comments 03



Project Details

Town of Parker

PROJECT NUMBER
SP24-128

SITE PLAN 10	Julia Duncan	1/3/2025	2/3/2025	2/4/2025	REVISIONS REQUIRED	01 REVIEW 20	<p>From: Duncan, Julia <jduncan@parkerco.gov> Sent: Tuesday, February 4, 2025 4:55 PM To: nsalazar@atwell.com <nsalazar@atwell.com>; tony@br.coffee <tony@br.coffee>; Brad@wildercolorado.com <Brad@wildercolorado.com> Subject: SP24-128 STAFF COMMENTS REVIEW 01</p> <p style="text-align: center;">Good Morning,</p> <p>Staff has completed the review for SP24-128. Attached are the Planning Division’s comments and redlines for the first round of review. A copy of these documents are also available in the project file in eTRAKiT. Please note, all other reviews referenced within the comment letter can be found in eTRAKiT. If you would like to schedule time to discuss these comments in detail, please email me and we will get something on the calendar. If you prefer to address the comments and resubmit, please email me when your resubmittal is made so that I can send the information out for the next review cycle. Please let me know if you have any questions.</p> <p style="text-align: center;">Sincerely,</p> <p style="text-align: center;">Julia</p>
SITE PLAN 15	Amber Wood Hicken	3/19/2025	4/9/2025	4/9/2025	REVISIONS REQUIRED		See planning comments 02



Project Details

Town of Parker

PROJECT NUMBER
SP24-128

SITE PLAN 20	Amber Wood Hicken	8/26/2025	9/10/2025	9/10/2025	REVISIONS REQUIRED		See planning comments 04
SITE PLAN 20	Cynthia Liston Thye	9/26/2025	10/6/2025	9/26/2025	REVISIONS REQUIRED		
TRAFFIC IMPACT STUDY - CIVIL 10	Charles Kudlauskas	7/8/2025	7/21/2025	7/21/2025	COMPLETED		
TRAFFIC IMPACT STUDY - CIVIL 10	Charles Kudlauskas	1/3/2025	2/3/2025	1/31/2025	REVISIONS REQUIRED	See uploaded Memo and Redlines.	
TRAFFIC IMPACT STUDY - CIVIL 15	Charles Kudlauskas	3/19/2025	4/9/2025	4/4/2025	REVISIONS REQUIRED	See uploaded Memo.	
URBAN DRAINAGE AND FLOOD CONTROL 10	UDFCD	1/3/2025	2/3/2025			01 REVIEW 20	

BOND INFORMATION

ATTACHMENTS

Attachment Type	CREATED	OWNER	DESCRIPTION	PATHNAME	SUBDIR	ETRAKIT ENABLED
DOC	4/9/2025	Amber Wood Hicken	Planning Comments 02 AWH SP24-128.pdf	Planning Comments 02 AWH SP24-128.pdf		1
DOC	7/21/2025	Amber Wood Hicken	Planning Comments 03 AWH SP24-128.pdf	Planning Comments 03 AWH SP24-128.pdf		1
DOC	8/26/2025	Amber Wood Hicken	04 SUB - Civil Plan Set - BRC - SP24-128.pdf	04 SUB - Civil Plan Set - BRC - SP24-128.pdf		1
DOC	9/10/2025	Amber Wood Hicken	CDOT Comments SP24-128 9-10-2025.pdf	CDOT Comments SP24-128 9-10-2025.pdf		1
DOC	2/4/2025	Charles Kudlauskas	24.5743 - BRC S Parker Road _ Stroh Road Traffic Statement Markup ER1.pdf	24.5743 - BRC S Parker Road _ Stroh Road Traffic Statement Markup ER1.pdf		1
DOC	2/4/2025	Charles Kudlauskas	24003198 - DRAINAGE NARRATIVE Markup ER1.pdf	24003198 - DRAINAGE NARRATIVE Markup ER1.pdf		1

ATTACHMENTS

Attachment Type	CREATED	OWNER	DESCRIPTION	PATHNAME	SUBDIR	ETRAKIT ENABLED
DOC	2/4/2025	Charles Kudlauskas	BRC - Parker Pointe - Civil CDs Markup ER1.pdf	BRC - Parker Pointe - Civil CDs Markup ER1.pdf		1
DOC	2/4/2025	Charles Kudlauskas	SP24-128 ToP Engineering Memo_Review1.pdf	SP24-128 ToP Engineering Memo_Review1.pdf		1
DOC	4/4/2025	Charles Kudlauskas	24003198 - DRAINAGE NARRATIVE_1 Markup ER2.pdf	24003198 - DRAINAGE NARRATIVE_1 Markup ER2.pdf		1
DOC	4/4/2025	Charles Kudlauskas	BRC - Parker _ Stroh - Paker CO - Site Plan - SUB 2 - Civil Plan Set - 2024-03-18 Markup ER2.pdf	BRC - Parker _ Stroh - Paker CO - Site Plan - SUB 2 - Civil Plan Set - 2024-03-18 Markup ER2.pdf		1
DOC	4/4/2025	Charles Kudlauskas	SP24-128 ToP Engineering Memo_Review2.pdf	SP24-128 ToP Engineering Memo_Review2.pdf		1
DOC	7/21/2025	Charles Kudlauskas	SP24-128 ToP Engineering Memo_Review3.pdf	SP24-128 ToP Engineering Memo_Review3.pdf		1
DOC	9/3/2025	Charles Kudlauskas	SP24-128 ToP Engineering Memo_Review4.pdf	SP24-128 ToP Engineering Memo_Review4.pdf		1
DOC	12/9/2024	Etrakit Contractor	01 Photometric Plan - Parker Pointe Coffee	BRC Parker, CO - Photometric - Site Plan.pdf		1
DOC	12/9/2024	Etrakit Contractor	Alta Survey - Parker Pointe Coffee	Existing Conditions Map.pdf		1
DOC	12/9/2024	Etrakit Contractor	Plat Master Landscape Plan - Parker Pointe Coffee	Master Landscape Plans.pdf		1



Project Details

Town of Parker

PROJECT NUMBER
SP24-128

ATTACHMENTS						
Attachment Type	CREATED	OWNER	DESCRIPTION	PATHNAME	SUBDIR	ETRAKIT ENABLED
DOC	12/9/2024	Etrakit Contractor	01 Traffic - Parker Pointe Coffee	24.5743 - BRC S Parker Road _ Stroh Road Traffic Statement.pdf		1
DOC	12/9/2024	Etrakit Contractor	01 Drainage - Parker Pointe Coffee	24003198 - DRAINAGE NARRATIVE.pdf		1
DOC	12/9/2024	Etrakit Contractor	Geotechnical Report - Parker Pointe Coffee	Parker Pointe Geotechnical Report - signed[7][49][56].pdf		1
DOC	12/9/2024	Etrakit Contractor	Civil CDs Landscape Plan and PWSD CDs - Parker Pointe Coffee	24003198 - BRC - Parker _ Stroh - Parker CO - Prelim Complete Set.pdf		1
DOC	12/9/2024	Etrakit Contractor	Application Packet - Parker Pointe Coffee	Site Plan Amendment Packet 2024.pdf		1
DOC	12/10/2024	Etrakit Contractor	Site Plan - Parker Pointe Coffee	BRC - Parker Pointe - Site Plan with LS.pdf		1
DOC	12/10/2024	Etrakit Contractor	PWSD DCs - Parker Pointe Coffee	BRC - Parker Pointe - PWSD CDs.pdf		1
DOC	12/10/2024	Etrakit Contractor	01 Civil CDs - Parker Pointe Coffee	BRC - Parker Pointe - Civil CDs.pdf		1
DOC	12/10/2024	Etrakit Contractor	Utility Study - Parker Pointe Coffee	Black Rock Coffee Utility Report Final Stamped.pdf		1
DOC	12/10/2024	Etrakit Contractor	Floor Plan - Parker Pointe Coffee	A1.0 Floor Plan CAFE 11-19-24.pdf		1
DOC	12/10/2024	Etrakit Contractor	01 Color Elevation 2 - Parker Pointe Coffee	Color elevs cafe[72].pdf		1
DOC	12/10/2024	Etrakit Contractor	01 Color Elevation 1 - Parker Pointe Coffee	Color elevs cafe 2of2 [70].pdf		1
DOC	12/17/2024	Etrakit Contractor	Charge Back Agreement	Charge Back Agreement (signed).pdf		1

ATTACHMENTS						
Attachment Type	CREATED	OWNER	DESCRIPTION	PATHNAME	SUBDIR	ETRAKIT ENABLED
DOC	4/2/2025	Etrakit Contractor	02 SUB - Civil Plan Set - BRC - SP24-128	02 SUB - Civil Plan Set - BRC - SP24-128.pdf		1
DOC	4/2/2025	Etrakit Contractor	02 SUB - Core Comment Response Letter - BRC - SP24-128	02 SUB - Core Comment Response Letter - BRC - SP24-128.pdf		1
DOC	4/2/2025	Etrakit Contractor	02 SUB - Engineering Comment Response Letter	02 SUB - Engineering Comment Response Letter - BRC - SP24-128.pdf		1
DOC	4/2/2025	Etrakit Contractor	02 SUB - Drainage Narrative	02 SUB - Drainage Narrative - BRC - SP24-128 .pdf		1
DOC	4/2/2025	Etrakit Contractor	02 SUB - Fire Comment Response Letter - BRC - SP24-128	02 SUB - Fire Comment Response Letter - BRC - SP24-128.pdf		1
DOC	4/2/2025	Etrakit Contractor	02 SUB PWSD Comment Response Letter - BRC - SP24-128	02 SUB - PWSD Comment Response Letter - BRC - SP24-128.pdf		0
DOC	4/2/2025	Etrakit Contractor	02 SUB - Site Plan	02 SUB - Site Plan - BRC - SP24-128.pdf		1
DOC	4/2/2025	Etrakit Contractor	02 SUB - Staff Comment Response Letter	02 SUB - Staff Comment Resonse Letter - BRC - SP24-128.pdf		1
DOC	4/2/2025	Etrakit Contractor	02 SUB - Traffic Impact Statement Comment Response Letter	02 SUB - Traffic Impact Statement Comment Response Letter - BRC - SP24-128.pdf		1
DOC	4/2/2025	Etrakit Contractor	02 SUB - Traffic Impact Statement	02 SUB - Traffic Impact Statement - BRC - SP24-128.pdf		1

ATTACHMENTS

Attachment Type	CREATED	OWNER	DESCRIPTION	PATHNAME	SUBDIR	ETRAKIT ENABLED
DOC	4/2/2025	Etrakit Contractor	02 SUB - PWSD Set	02 SUB - PWSD Set - BRC - SP24-128.pdf		1
DOC	4/3/2025	Etrakit Contractor	SUB 02 - BRC - SITE PLAN - SP24-128	SUB 02 - BRC - SITE PLAN - SP24-128.pdf		1
DOC	4/3/2025	Etrakit Contractor	SUB 02 - BRC - CIVIL CD SET - SP24-128	SUB 02 - BRC - CIVIL CD SET - SP24-128.pdf		1
DOC	8/25/2025	Etrakit Contractor	SP Responses	04 SUB - Planning Comment Response Letter AWH SP24-128.pdf		1
DOC	8/25/2025	Etrakit Contractor	CORE	04 SUB - CORE 3rd Review - Site Plan Set - BRC - SP24-128 7-18-25 - Comment Response.pdf		1
DOC	8/25/2025	Etrakit Contractor	Engineering Responses	04 SUB - SP24-128 ToP Engineering Memo_Review3_Comm ent Response.pdf		1
DOC	8/25/2025	Etrakit Contractor	Site Plan	04 SUB - Site Plan Set - BRC - SP24-128.pdf		1
DOC	8/25/2025	Etrakit Contractor	04 SUB - Drainage Narrative	04 SUB - DRAINAGE NARRATIVE.pdf		1
DOC	9/24/2025	Etrakit Contractor	Engineering Responses	04 - ToP Engineering Memo_Review3_Comm ent Response SP24-128 .pdf		1
DOC	9/24/2025	Etrakit Contractor	05 SUB - Civil Plan Set - BRC - Sp24-128	04 - Statement of Authority - BRC - SP24-128.pdf		1

ATTACHMENTS

Attachment Type	CREATED	OWNER	DESCRIPTION	PATHNAME	SUBDIR	ETRAKIT ENABLED
DOC	9/24/2025	Etrakit Contractor	05 SUB - Statement of Authority - BRC - SP24-128	04 - Black Rock Coffee Parker - CDOT SP24-128.pdf		1
DOC	9/24/2025	Etrakit Contractor	CDOT Responses	04 - DRAINAGE NARRATIVE SP24-128.pdf		1
DOC	9/24/2025	Etrakit Contractor	05 SUB - Drainage Narrative	04- Civil Plan Set SP24-128.pdf		1
DOC	2/4/2025	Julia Duncan	SP24-128 STAFF COMMENTS REVIEW 01.pdf	SP24-128 STAFF COMMENTS REVIEW 01.pdf		1
DOC	6/10/2025	Jason Murray	03 SUB - BRC - S Parker Road and Stroh Road - Traffic Impact Study.pdf	03 SUB - BRC - S Parker Road and Stroh Road - Traffic Impact Study.pdf		1
DOC	6/10/2025	Jason Murray	03 SUB - Civil Plan Set - BRC - 2024-03-18 Markup ER2_Comment Response Letter.pdf	03 SUB - Civil Plan Set - BRC - 2024-03-18 Markup ER2_Comment Response Letter_1.pdf		1
DOC	6/10/2025	Jason Murray	03 SUB - Civil Plan Set - BRC - SP24-128.pdf	03 SUB - Civil Plan Set - BRC - SP24-128.pdf		1
DOC	6/10/2025	Jason Murray	03 SUB - DRAINAGE NARRATIVE.pdf	03 SUB - DRAINAGE NARRATIVE.pdf		1
DOC	6/10/2025	Jason Murray	03 SUB - DRAINAGE NARRATIVE_1 Markup ER2_Comment Response.pdf	03 SUB - DRAINAGE NARRATIVE_1 Markup ER2_Comment Response.pdf		1
DOC	6/10/2025	Jason Murray	03 SUB - Planning Comment Response Letter AWH SP24-128.pdf	03 SUB - Planning Comment Response Letter AWH SP24-128_1.pdf		1

ATTACHMENTS

Attachment Type	CREATED	OWNER	DESCRIPTION	PATHNAME	SUBDIR	ETRAKIT ENABLED
DOC	6/10/2025	Jason Murray	03 SUB - PWSD - SP24-128 - UTILITY PLAN SET.pdf	03 SUB - PWSD - SP24-128 - UTILITY PLAN SET.pdf		1
DOC	6/10/2025	Jason Murray	03 SUB - Renderings Day and Night - Site Plan Set - BRC - SP24-128.pdf	03 SUB - Renderings Day and Night - Site Plan Set - BRC - SP24-128.pdf		1
DOC	6/10/2025	Jason Murray	03 SUB - RR Rev Ltr 4 9 25 Comment Response Letter.pdf	03 SUB - RR Rev Ltr 4 9 25 Comment Response Letter.pdf		1
DOC	6/10/2025	Jason Murray	03 SUB - Site Plan Set - BRC - SP24-128.pdf	03 SUB - Site Plan Set - BRC - SP24-128_1.pdf		1
DOC	6/10/2025	Jason Murray	03 SUB - SP24-128 Parker Pointe F1 AMD 1 L4A - Drive Through Coffee Shop 3 Fire Life Safety Response Ltr_Comment Response.pdf	03 SUB - SP24-128 Parker Pointe F1 AMD 1 L4A - Drive Through Coffee Shop 3 Fire Life Safety Response Ltr_Comment Response.pdf		1
DOC	6/10/2025	Jason Murray	03 SUB - SP24-128 ToP Engineering Memo_Review2_Comm ent Response Letter.pdf	03 SUB - SP24-128 ToP Engineering Memo_Review2_Comm ent Response Letter_1.pdf		1
DOC	6/10/2025	Jason Murray	20-Foot Fire Hydrant Exclusive Easement Agree - SIGNED.pdf	20-Foot Fire Hydrant Exclusive Easement Agree - SIGNED.pdf		1
DOC	6/10/2025	Jason Murray	LETTER OF CREDIT .pdf	LETTER OF CREDIT .pdf		1
DOC	6/10/2025	Jason Murray	SIA Improvement Agreement - SIGNED.pdf	SIA Improvement Agreement - SIGNED.pdf		1

ATTACHMENTS						
Attachment Type	CREATED	OWNER	DESCRIPTION	PATHNAME	SUBDIR	ETRAKIT ENABLED
DOC	1/15/2025	Randy Capra	SP24-128 Parker Pointe F1 AMD 1 L4A - Drive Through Coffee Shop [1] Fire Life Safety Response Ltr 011525.docx	SP24-128 Parker Pointe F1 AMD 1 L4A - Drive Through Coffee Shop [1] Fire Life Safety Response Ltr 011525.docx		1
DOC	1/15/2025	Randy Capra	SP24-128 Parker Pointe F1 AMD 1 L4A - Drive Through Coffee Shop [1] Fire Life Safety Response Ltr 011525.pdf	SP24-128 Parker Pointe F1 AMD 1 L4A - Drive Through Coffee Shop [1] Fire Life Safety Response Ltr 011525.pdf		1
DOC	3/26/2025	Randy Capra	SP24-128 Parker Pointe F1 AMD 1 L4A - Drive Through Coffee Shop [2] Fire Life Safety Response Ltr 032625.docx	SP24-128 Parker Pointe F1 AMD 1 L4A - Drive Through Coffee Shop [2] Fire Life Safety Response Ltr 032625.docx		0
DOC	3/26/2025	Randy Capra	SP24-128 Parker Pointe F1 AMD 1 L4A - Drive Through Coffee Shop [2] Fire Life Safety Response Ltr 032625.pdf	SP24-128 Parker Pointe F1 AMD 1 L4A - Drive Through Coffee Shop [2] Fire Life Safety Response Ltr 032625.pdf		0
DOC	4/7/2025	Randy Capra	SP24-128 Parker Pointe F1 AMD 1 L4A - Drive Through Coffee Shop [3] Fire Life Safety Response Ltr 040725.docx	SP24-128 Parker Pointe F1 AMD 1 L4A - Drive Through Coffee Shop [3] Fire Life Safety Response Ltr 040725.docx		1

ATTACHMENTS

Attachment Type	CREATED	OWNER	DESCRIPTION	PATHNAME	SUBDIR	ETRAKIT ENABLED
DOC	4/7/2025	Randy Capra	SP24-128 Parker Pointe F1 AMD 1 L4A - Drive Through Coffee Shop [3] Fire Life Safety Response Ltr 040725.pdf	SP24-128 Parker Pointe F1 AMD 1 L4A - Drive Through Coffee Shop [3] Fire Life Safety Response Ltr 040725.pdf		1
DOC	7/9/2025	Randy Capra	RFCC SP24-128 Parker Pointe F1 AMD 1 L4A - Drive Through Coffee Shop [4] Fire Life Safety Response Ltr 070925.pdf	RFCC SP24-128 Parker Pointe F1 AMD 1 L4A - Drive Through Coffee Shop [4] Fire Life Safety Response Ltr 070925.pdf		1
DOC	4/2/2025	Robert Seacat	REDLINED EROSION CONTROL Pages from - Civil Plan Set - BRC - SP24-128.pdf	REDLINED EROSION CONTROL Pages from - Civil Plan Set - BRC - SP24-128.pdf		1
DOC	1/31/2025	Brooks Kaufman	CORE COMMENTS REV1 1-31-25	CORE COMMENTS 1-31-25 REV1 SP24-128.pdf		1
DOC	1/31/2025	Brooks Kaufman	CORE 3PH TRANSFORMER CLEARANCES	CORE THREE PHASE TRANSFORMER.pdf		1
DOC	1/31/2025	Brooks Kaufman	CORE Builder Handbook Updated 2024	COREBuilderDeveloperserviceRequirements020824.pdf		1
DOC	7/18/2025	Brooks Kaufman	CORE REVIEW 3 7-18-25	CORE 3rd review - Site Plan Set - BRC - SP24-128 7-18-25.pdf		1
DOC	1/28/2025	Donna George	PSCo response 1.28.2025	PSCo resp - Parker Pointe F1 AMD 1 L4A - Drive Through Coffee Shop SP24-128.pdf		1



Project Details

Town of Parker

PROJECT NUMBER
SP24-128

ATTACHMENTS						
Attachment Type	CREATED	OWNER	DESCRIPTION	PATHNAME	SUBDIR	ETRAKIT ENABLED
DOC	1/24/2025	DC Referrals	Douglas County Comments	Referral Comments Report.pdf		1
DOC	2/3/2025	Robert Ramsey	Red lined plans	BRC - Parker Pointe - PWSD CDs_1.pdf		1
DOC	4/9/2025	Robert Ramsey	Review letter	RR Rev ltr 4 9 25.pdf		1
DOC	4/9/2025	Robert Ramsey	Red lined plans	Easement Agreement Fire Hydrant Exclusive.pdf		1
DOC	4/9/2025	Robert Ramsey		Easement Agreement Fire Hydrant Exclusive_1.pdf		1
DOC	4/9/2025	Robert Ramsey	Red lined plans	02 SUB - PWSD Set - BRC - SP24-128_1.pdf		1

LOT 4A, PARKER POINT SUBDIVISION FILING NO. 1, AMENDMENT NO. 1

SITE PLAN FOR



LOCATED AT S. PARKER RD & STROH RD
CITY OF PARKER, DOUGLAS COUNTY, STATE OF COLORADO
TOTAL SITE ACREAGE: 0.60 AC

CALL UTILITY NOTIFICATION CENTER OF COLORADO
1-800-922-1987
CALL 2-BUSINESS DAYS IN ADVANCE BEFORE YOU DIG, GRADE, OR EXCAVATE FOR THE MARKING OF UNDERGROUND MEMBER UTILITIES.

THE TYPE, SIZE, LOCATION, AND NUMBER OF ALL KNOWN UNDERGROUND UTILITIES ARE APPROXIMATE WHEN SHOWN ON THE DRAWINGS. IT SHALL BE THE RESPONSIBILITY OF THE CONTRACTOR TO VERIFY THE EXISTENCE AND LOCATION OF ALL UNDERGROUND UTILITIES ON THE SITE, AND OFFSITE IN WORK AREAS. LOCATION OF EXISTING UTILITIES SHALL BE VERIFIED BY CONTRACTOR PRIOR TO DATE OF CONSTRUCTION. FOR INFORMATION CONTACT: UTILITY NOTIFICATION CENTER OF COLORADO (UNCC) - 1-800-922-1987. IT IS THE CONTRACTOR'S RESPONSIBILITY TO FIELD VERIFY SIZE AND HORIZONTAL AND VERTICAL LOCATIONS OF EXISTING FACILITIES PRIOR TO CONSTRUCTION AND NOTIFY THE ENGINEER OF ANY DISCREPANCIES.

THE CONTRACTOR SHALL BE RESPONSIBLE FOR ANY DAMAGE TO EXISTING IMPROVEMENTS AND UTILITIES AND SHALL REPAIR ANY DAMAGE AT HIS EXPENSE.

SITE AREA	
TOTAL PROPERTY AREA:	0.60 AC / 25,933 SF.
DISTURBED AREA:	0.67 AC / 29,406 SF.
IMPERVIOUS AREA:	0.40 AC / 17,639 SF.
LANDSCAPED AREA:	0.19 AC / 8,294 SF.
ZONING CLASSIFICATION	
JURISDICTION:	CITY OF PARKER
ZONING:	MIXED-USE COMMUNITY
ADJACENT ZONING:	PLANNED DEVELOPMENT
PROPOSED USE:	COMMERCIAL RESTAURANT WITH DRIVE THRU
BUILDING SETBACKS	
REQUIRED BUILDING SETBACK	
FRONT MIN BUILDING SETBACK	25'
FRONT MAX BUILDING SETBACK	NONE
SIDE MIN BUILDING SETBACK	5' (NONRESIDENTIAL)
SIDE MAX BUILDING SETBACK	10' (ADJACENT TO STREET)
REAR BUILDING SETBACK	5' MIN. WITH ALLEY
REAR BUILDING SETBACK	8' MIN. WITHOUT ALLEY
PROVIDED BUILDING SETBACK	
FRONT (W) BUILDING SETBACK	65.2'
SIDE (S) BUILDING SETBACK	18'
SIDE (N) BUILDING SETBACK	51.5'
REAR (E) BUILDING SETBACK	113.5'
BUILDING SUMMARY	
PROPOSED BUILDING AREA:	1,495 SF
REQUIRED BUILDING HEIGHT LIMIT:	45'
PROVIDED BUILDING HEIGHT:	±20'
PROPOSED NUMBER OF BUILDINGS:	1
PARKING SUMMARY	
PARKING REQUIREMENTS	
1 SPACE PER EACH 4 PERSONS OF RATED CAPACITY OF 37 PEOPLE (EXCLUDING OUTDOOR SEATING)	
10 SPACES	
12 SPACES (INCLUDING 1 ADA SPACE)	
DRIVE-THROUGH STACKING PROVIDED	
BIKE SPACES REQUIREMENTS	
1 REQUIRED - 10% OF VEHICLE SPACES PROVIDED	
TOTAL BIKE PARKING PROVIDED	
4 SPACES	

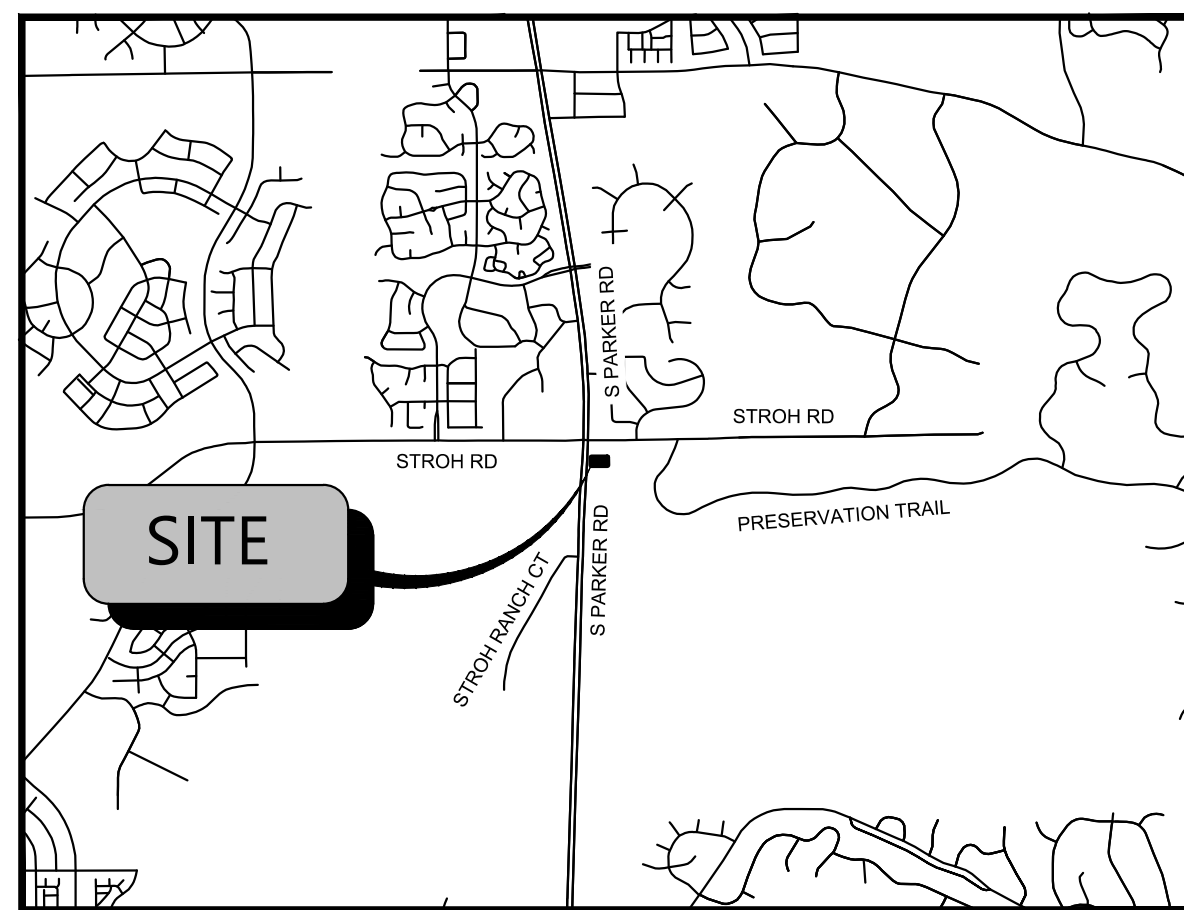

VICINITY MAP
N.T.S.



FEMA MAP
N.T.S.

NOTE: BASED ON GRAPHIC DETERMINATION, THIS PROPERTY DOES NOT LIE IN A F.E.M.A./F.I.R.M SPECIAL FLOOD HAZARD AREA PER COMMUNITY PANEL NO. 08035C0182G DATED MARCH, 16 2016.



AERIAL MAP
N.T.S.

TOWN OF PARKER PLAN SET	
Sheet Number	Sheet Title
C0.00	COVER SHEET
C1.20	GENERAL NOTES
C2.00	SITE PLAN
SF-9	BICYCLE RACK
L1.01	LANDSCAPE PLAN
L1.02	LANDSCAPE SPECIFICATION AND NOTES
L1.03	LANDSCAPE DETAILS
L2.01	IRRIGATION PLAN
L2.02	IRRIGATION SPECIFICATIONS AND DETAILS
E0.1	ELECTRICAL NOTES & SYMBOLS
E1.0	ELECTRICAL SITE PLAN
E1.1	PHOTOMETRIC SITE PLAN
E1.2	EXTERIOR LIGHTING SPEC SHEETS
E4.0	ELECTRICAL ONE-LINE DIAGRAM
E4.1	ELECTRICAL PANEL SCHEDULES
E4.2	ELECTRICAL GEAR DETAILS
E5.0	ELECTRICAL SPECIFICATIONS
A1.0	DUMPSTER ENCLOSURE PLAN AND ELEVATIONS
A6.0	EXTERIOR ELEVATION (COLOR)
A6.1	EXTERIOR ELEVATION (COLOR)

BLACK ROCK COFFEE BAR
TOTAL SITE AREA: 0.60 AC / 25,933 SF.
DISTURBED AREA: 0.67 AC / 29,406 SF.
ZONING: MIXED-USE COMMUNITY (MC)

DEVELOPMENT TEAM

OWNER	CIVIL ENGINEER	SURVEYOR	DEVELOPER
DOUBLETREE VENTURES, LLC P.O. BOX 40326 DENVER, CO 80204 CONTACT: BRIAN ZUREK EMAIL: BRIAN@DOUBLETREEVENTURES.COM	ATWELL, LLC 9001 AIRPORT FREEWAY, SUITE 660 NORTH RICHLAND HILLS, TX 76180 PHONE: (###) ###-#### CONTACT: NICHOLAS SALAZAR EMAIL: NSALAZAR@ATWELL.COM	BARRON LAND 2790 N. ACADEMY BLVD., SUITE 311 COLORADO SPRINGS, CO 80917 PHONE: (719) 360-6827 CONTACT: SPENCER BARRON	BLACK ROCK COFFEE BAR 16307 NE CAMERON BLVD PORTLAND, OR 97230 PHONE: (541) 531-2149 CONTACT: TONY POLLOTTA

GOVERNING AGENCIES AND UTILITY CONTACTS

WATER & WASTEWATER	FIRE PROTECTION	GAS PROVIDER
PARKER WATER AND SANITATION DISTRICT 13939 ANCESTRY DRIVE PARKER, CO 80134 PHONE: (303) 841-4627 EMAIL: RRAMSEY@PWSD.ORG CONTACT: ROBERT RAMSEY	TOWN OF PARKER FIRE AND LIFE SAFETY 20120 E. MAINSTREET PARKER, CO 80138 PHONE: (303) 805-3169 CONTACT: RANDY CAPRA EMAIL: RCAPRA@PARKERONLINE.ORG	XCEL ENERGY 1123 WEST 3RD AVE. DENVER, CO 80223 PHONE: (303) 571-3927 CONTACT: BUILDER'S CALL LINE (800) 628-1212 X3
ENGINEERING DEPARTMENT	BUILDING PERMIT	PHONE PROVIDER
TOWN OF PARKER ENGINEERING & PUBLIC WORKS 20120 E. MAINSTREET PARKER, CO 80134 PHONE: (303) 840-9546 EMAIL: CKUDLAUSKAS@PARKERCO.GOV CONTACT: CHARLES KUDLAUSKAS	TOWN OR PARKING BUILDING DIVISION 20120 E. MAINSTREET PARKER, CO 80138 PHONE: (303) 841-1970 CONTACT: RANDY SALE EMAIL: RSALE@PARKERONLINE.ORG	CENTURYLINK 9750 EAST COSTILLA AVE. ENGLEWOOD, CO 80112 PHONE: (720) 578-5142
		ELECTRIC PROVIDER
		CORE ELECTRIC COOPERATIVE 5496 NORTH U.S. HIGHWAY 85 SEDALIA, CO 80135 PHONE: (303) 332-9540 CONTACT: BRUFF SHEA

PROJECT NARRATIVE

BLACK ROCK COFFEE BAR IS OWNED BY BLACK ROCK DEVELOPMENT COMPANY, LLC. THEY ARE A PREMIUM CRAFT COFFEE SHOP WITH MULTIPLE LOCATIONS ACROSS THE COUNTRY. THEY CONSIDER THEMSELVES A "PART OF LOCAL COMMUNITIES, EACH BLACK ROCK COFFEE BAR TEAM FINDS WAYS TO SERVE THEIR NEIGHBORHOODS, AND BY DOING SO WE HELP RAISE THE BAR FOR RELATIONSHIP AND COMPASSION." THEIR PROTOTYPE BUILDING IS ROUGHLY 600-700 SQUARE FEET IN SIZE, WITH STATE-OF-THE-ART DESIGN AND IDENTIFIABLE BRANDING ELEMENTS. THEY OFFER PATIO AND INDOOR SEATING WITH THE OPTION OF DRIVE-THRU AVAILABILITY.

A BUILDING WITH THE STANDARD DUAL-LANE ORDERING SINGLE LANE PICKUP IS BEING PROPOSED FOR THIS LOCATION. THIS PROJECT WOULD UTILIZE A PROPOSED ACCESS POINT TO DECLAN DRIVE.

LEGAL DESCRIPTION

LOT 4A, PARKER POINT SUBDIVISION FILING NO. 1, AMENDMENT NO. 1 ACCORDING TO THE PLAT AS RECORDED JULY 31, 2024 AT RECEPTION NO. 2024031650, COUNTY OF DOUGLAS, STATE OF COLORADO

ADDRESS OF RECORD:
6940 STROH ROAD, PARKER, CO

BENCHMARK

ELEVATIONS ARE BASED UPON DOUGLAS COUNTY GIS SECONDARY CONTROL MONUMENT "1.060032" (ELEVATION - 5903.17 NAVD88)

BASIS OF BEARINGS

BEARINGS ARE BASED UPON THE NORTH LINE OF THE NORTHEAST QUARTER OF SECTION 3, T7S, R66W OF THE 6TH PRINCIPAL MERIDIAN, MONUMENTED ON THE EAST WITH A #6 REBAR WITH 2" ALUMINUM CAP IN MONUMENT BOX STAMPED "PLS 22561" AND ON THE WEST WITH A #6 REBAR WITH A 3.25" ALUMINUM CAP IN MONUMENT BOX STAMPED "PLS 29761", AND IS ASSUMED TO BEAR S 89°59'29" W, A FIELD MEASURED DISTANCE OF 2648.43 FEET.



Know what's Below. Call before you dig.
THE LOCATIONS OF EXISTING UNDERGROUND UTILITIES ARE SHOWN BY AN APPROXIMATE WAY ONLY AND HAVE NOT BEEN REPRESENTATIVE. THE CONTRACTOR SHALL DETERMINE THE EXACT LOCATION OF ALL EXISTING UTILITIES BEFORE COMMENCING WORK AND AGREES TO BE FULLY RESPONSIBLE FOR ANY AND ALL DAMAGES WHICH MAY BE INCURRED BY THE CONTRACTOR'S FAILURE TO LOCATE AND PRESERVE ANY AND ALL UNDERGROUND UTILITIES.

NOTICE:
CONSTRUCTION SITE SAFETY IS THE SOLE RESPONSIBILITY OF THE CONTRACTOR. NEITHER THE OWNER NOR THE ENGINEER SHALL BE HELD RESPONSIBLE FOR ANY PERSONS ENGAGED IN THE WORK OF ANY NEARBY STRUCTURES, OR OF ANY OTHER PERSONS.
COPYRIGHT © 2025 ATWELL LLC. NO REPRODUCTION SHALL BE MADE WITHOUT THE PRIOR WRITTEN CONSENT OF ATWELL LLC.

ATWELL
www.atwell-group.com
866.850.4200
9001 AIRPORT FREEWAY, SUITE 660
NORTH RICHLAND HILLS, TX 76180
972.256.8660

LOT 4A, PARKER POINT SUBD. FILING NO. 1, AMEND. NO. 1
S. PARKER RD & STROH RD
PARKER
DOUGLAS COUNTY, COLORADO

BLACK ROCK COFFEE BAR
13135 DECLAN DRIVE
BLACK ROCK COFFEE BAR
COVER SHEET

DATE: 2025-08-25

REVISIONS

DRAWN BY: K. SARWAR
CHECKED BY: N. SALAZAR
PROJECT MANAGER: N. SALAZAR
JOB #: 24003198
FILE CODE: ##
SHEET NO:
C0.00

PROJECT GENERAL NOTES

GENERAL NOTES

1. ALL MATERIALS, WORKMANSHIP, AND CONSTRUCTION OF IMPROVEMENTS SHALL MEET OR EXCEED THE CITY AND APPLICABLE UTILITY DISTRICT STANDARDS AND SPECIFICATIONS, AND APPLICABLE STATE AND FEDERAL REGULATIONS. WHERE THERE IS A CONFLICT BETWEEN THESE PLANS AND ANY APPLICABLE STANDARDS, THE HIGHER QUALITY STANDARD SHALL APPLY. ALL WORK WITHIN THE PUBLIC RIGHT-OF-WAY SHALL BE DONE IN ACCORDANCE WITH THE GOVERNING AUTHORITY'S STANDARDS AND SPECIFICATIONS. ALL REFERENCES TO PUBLISHED STANDARDS SHALL REFER TO THE LATEST REVISION OF SAID STANDARDS, UNLESS SPECIFICALLY STATED OTHERWISE.
2. THE CONTRACTOR IS RESPONSIBLE FOR PROVIDING ALL LABOR AND MATERIALS NECESSARY FOR THE COMPLETION OF THE INTENDED IMPROVEMENTS SHOWN ON THESE PLANS OR DESIGNATED TO BE PROVIDED, INSTALLED, CONSTRUCTED, REMOVED, AND RELOCATED UNLESS SPECIFICALLY NOTED OTHERWISE.
3. UTILITY TRENCHES ARE TO BE SLOPED OR BRACED AND SHEETED AS NECESSARY TO FURNISH SAFE WORKING CONDITIONS FOR THE WORKMEN AND THE PROTECTION OF OTHER UTILITIES IN COMPLIANCE WITH APPLICABLE LOCAL, STATE, AND FEDERAL HEALTH AND SAFETY RULES AND REGULATIONS.
4. THE CONTRACTOR IS SPECIFICALLY CAUTIONED THAT THE LOCATION AND/OR ELEVATION OF EXISTING UTILITIES, AS SHOWN ON THESE PLANS, IS BASED ON RECORDS OF THE VARIOUS UTILITY COMPANIES AND WHERE POSSIBLE, MEASUREMENTS TAKEN IN THE FIELD. THE INFORMATION IS NOT TO BE RELIED ON AS BEING EXACT OR COMPLETE. THE CONTRACTOR MUST CALL THE LOCAL UTILITY LOCATION CENTER BEFORE ANY EXCAVATION TO REQUEST EXACT FIELD LOCATIONS OF THE UTILITIES. PRIOR TO CONSTRUCTION THE CONTRACTOR SHALL VERIFY PERTINENT LOCATIONS AND ELEVATIONS, ESPECIALLY AT CONNECTION POINTS AND POTENTIAL UTILITY CONFLICTS. IT SHALL BE THE RESPONSIBILITY OF THE CONTRACTOR TO RELOCATE ALL EXISTING UTILITIES THAT CONFLICT WITH THE PROPOSED IMPROVEMENTS SHOWN ON THESE PLANS AND TO COORDINATE SUCH RELOCATIONS WITH THE APPROPRIATE UTILITY PROVIDER AND ALL AFFECTED PARTIES.
5. IT IS THE RESPONSIBILITY OF THE CONTRACTOR TO COORDINATE WITH THE APPROPRIATE UTILITY COMPANY/DISTRICT TO OBTAIN TEMPORARY POWER, TELEPHONE, AND WATER SERVICE DURING CONSTRUCTION. ALL COST FOR TEMPORARY SERVICES SHALL BE THE CONTRACTOR'S RESPONSIBILITY.
6. THE CONTRACTOR SHALL COORDINATE AND COOPERATE WITH THE CITY AND ALL UTILITY COMPANIES/DISTRICTS INVOLVED WITH REGARD TO RELOCATIONS OR ADJUSTMENTS OF EXISTING UTILITIES DURING CONSTRUCTION AND TO ASSURE THAT THE WORK IS ACCOMPLISHED IN A TIMELY FASHION AND WITH A MINIMUM DISRUPTION OF SERVICE. THE CONTRACTOR SHALL BE RESPONSIBLE FOR CONTACTING ALL PARTIES AFFECTED BY ANY UTILITY SERVICE.
7. IT IS THE RESPONSIBILITY OF THE CONTRACTOR TO COORDINATE ALL UTILITY RELOCATIONS, WHETHER SHOWN OR NOT SHOWN ON THE PLANS.
8. THE CONTRACTOR SHALL BE RESPONSIBLE FOR ALL ASPECTS OF PROJECT SAFETY INCLUDING, BUT NOT LIMITED TO, EXCAVATION, TRENCHING, SHORING, TRAFFIC CONTROL, AND SECURITY.
9. THE CONTRACTOR SHALL INSTALL AND MAINTAIN CONSTRUCTION FENCE PRIOR TO, AND THROUGHOUT CONSTRUCTION.
10. THE CONTRACTOR SHALL BE RESPONSIBLE FOR COORDINATING ALL WORK AND INSPECTIONS AS REQUIRED BY THE CITY, STATE, OR LOCAL DISTRICTS. ALL NECESSARY INSPECTIONS AND/OR CERTIFICATIONS REQUIRED SHALL BE PERFORMED PRIOR TO ANNOUNCED BUILDING POSSESSION AND THE FINAL CONNECTION OF SERVICES. THE CONTRACTOR SHALL BE RESPONSIBLE FOR ALL COST ASSOCIATED WITH INSPECTION.
11. THE CONTRACTOR SHALL NOTIFY THE CITY AND LOCAL UTILITY COMPANIES/DISTRICTS AT LEAST 48 HOURS PRIOR TO THE START OF ANY CONSTRUCTION.
12. THE CONTRACTOR SHALL NOTIFY THE CITY AND LOCAL UTILITY COMPANIES/DISTRICTS AT LEAST 48 HOURS PRIOR TO THE START OF ANY EARTH DISTURBING ACTIVITY.
13. THE CONTRACTOR SHALL BE RESPONSIBLE FOR KEEPING ROADWAYS FREE AND CLEAR OF ALL CONSTRUCTION DEBRIS AND DIRT TRACKED FROM THE SITE.
14. INCLUDED IN THIS PACKAGE IS THE DEMOLITION AND DISPOSAL OF ALL EXISTING UTILITIES, SITE IMPROVEMENTS AND SITE FURNISHINGS NEEDED FOR CONSTRUCTION OF THE IMPROVEMENTS SHOWN IN THIS SET OF CONSTRUCTION DRAWINGS. ALL QUESTIONS IN REGARD TO DEMOLITION SHALL BE SUBMITTED TO THE OWNER IN WRITING PRIOR TO BID.
15. DIMENSIONS FOR LAYOUT AND CONSTRUCTION ARE NOT TO BE SCALED FROM ANY DRAWING. IF PERTINENT DIMENSIONS ARE NOT SHOWN, CONTACT THE CONSULTING ENGINEER FOR CLARIFICATION, AND ANNOTATE THE DIMENSION ON THE AS-BUILT RECORD DRAWINGS. COORDINATES PROVIDED ON THE DRAWING SHALL BE VERIFIED. ANY WORK DONE INCORRECTLY BASED UPON THE PROVIDED COORDINATES SHALL BE THE RESPONSIBILITY OF THE CONTRACTOR AND FIXED AT HIS OWN EXPENSE.
16. RIM ELEVATIONS SHOWN ARE APPROXIMATE ONLY AND ARE NOT TO BE TAKEN AS FINAL ELEVATIONS. THE CONTRACTOR SHALL USE PRECAST CONCRETE ADJUSTMENT RINGS, GROUT, AND STEEL SHIMS TO ADJUST THE MANHOLE FRAMES TO THE REQUIRED FINAL GRADE IN CONFORMANCE WITH THE CITY OR UTILITY COMPANY/DISTRICT STANDARD SPECIFICATIONS. ALL FRAMES SHALL BE ADJUSTED TO FINAL GRADE PRIOR TO THE FINAL LIFT OF ASPHALT.
17. IF, DURING THE CONSTRUCTION PROCESS, CONDITIONS ARE ENCOUNTERED BY THE CONTRACTOR, HIS SUBCONTRACTORS, OR OTHER AFFECTED PARTIES, WHICH COULD INDICATE A SITUATION THAT IS NOT IDENTIFIED IN THE PLANS OR SPECIFICATIONS, THE CONTRACTOR SHALL CONTACT THE PROJECT MANAGER FOR THE OWNER/DEVELOPER AND THE ENGINEER IMMEDIATELY.
18. BENCHMARK VERIFICATION: THE CONTRACTOR SHALL USE BENCHMARKS AND DATUMS SHOWN HEREON TO SET PROJECT BENCHMARK(S), BY RUNNING A LEVEL LOOP BETWEEN AT LEAST TWO BENCHMARKS, AND SHALL PROVIDE SURVEY NOTES OF SUCH TO PROJECT ENGINEER PRIOR TO COMMENCING CONSTRUCTION.
19. ALL WORK WITHIN THE PUBLIC RIGHT-OF-WAY SHALL BE DONE IN ACCORDANCE WITH THE GOVERNING AUTHORITY'S STANDARDS AND SPECIFICATIONS.

SITE/GRADING GENERAL NOTES

1. CONTOURS SHOWN REPRESENT FINISHED ELEVATIONS. ADJUSTMENT TO SUBGRADE FOR ALL STRUCTURES (IE PAVING, SIDEWALKS, SLABS, ETC) IS THE RESPONSIBILITY OF THE CONTRACTOR. IN ADDITION, THE CONTRACTOR IS RESPONSIBLE FOR HIS OWN ESTIMATE OF EARTHWORK QUANTITIES.
2. EXISTING SPOT ELEVATIONS AT MATCH POINTS WERE DERIVED FROM CONTOURS PROVIDED WITH THE SITE MAPPING AND ARE ANTICIPATED TO BE +/- AND SHALL BE VERIFIED PRIOR TO ANY CONSTRUCTION. ANY DEVIATION SHALL BE REPORTED TO THE ENGINEER.
3. PRIOR TO PLACING ANY CONCRETE CURB, GUTTER, PANS, AND ACCESSIBLE RAMPS, THE FORMWORK ELEVATIONS SHALL BE VERIFIED AND PROVIDED TO THE PROJECT ENGINEER FOR REVIEW AND APPROVAL. ANY WORK THAT DOES NOT COMPLY WITH THIS REQUIREMENT AND IS PLACED IN ERROR WILL BE THE RESPONSIBILITY OF THE CONTRACTOR.
4. NO PROPOSED LANDSCAPED SLOPE SHALL EXCEED 3:1, OR AS SPECIFIED OTHERWISE BY LOCAL CODE.
5. CONTRACTOR SHALL REFER TO BUILDING ARCHITECTURAL PLANS FOR EXACT DIMENSIONS AND LOCATIONS OF BUILDINGS AND APPURTENANCES. THE EARTHWORK FOR ALL BUILDING FOUNDATIONS AND SLABS SHALL BE IN ACCORDANCE WITH THE ARCHITECTURAL BUILDING PLANS AND SPECIFICATIONS AND THE GEOTECHNICAL REPORT PREPARED SPECIFICALLY FOR THIS SITE.
6. ALL LANDSCAPED AREAS ARE TO BE CONDITIONED PER THE REQUIREMENTS OF THE LANDSCAPE PLANS. ALL DISTURBED AREAS THAT ARE NOT DESIGNATED TO BE PAVED SHALL BE LANDSCAPED OR SEEDED ACCORDING TO THE LANDSCAPE PLAN(S) AND GRADING, EROSION AND SEDIMENT CONTROL PLAN(S).
7. ALL PROPOSED SPOT ELEVATIONS ARE FLOWLINE ELEVATIONS UNLESS OTHERWISE NOTED. SPOT ELEVATIONS TAKE PRECEDENCE OVER CONTOURS AND SLOPES SHOWN. CONTRACTOR SHALL NOTIFY ENGINEER OF SPOT ELEVATIONS WHICH DO NOT APPEAR TO BE CONSISTENT WITH THE CONTOURS AND SLOPES. SPOT ELEVATIONS AND SPECIFIC PROFILE DATA SHALL BE USED FOR SETTING ELEVATIONS OF CURB AND GUTTER AND UTILITIES. THE CONTRACTOR SHALL ADJUST AND/OR CUT EXISTING PAVEMENT AS NECESSARY TO ASSURE A SMOOTH FIT AND CONTINUOUS GRADE.
8. ASPHALT GRADES SHALL NOT BE LESS THAN 1.00% IN THE DIRECTION OF FLOW. CURB AND GUTTER AND CONCRETE PAN GRADES SHALL NOT BE LESS THAN 0.50% IN THE DIRECTION OF FLOW. THE CONTRACTOR SHALL MAINTAIN POSITIVE DRAINAGE IN ALL PAVEMENT AREAS AND ALONG ALL CURBS. PAVEMENT OR CURBS WHICH DO NOT PROVIDE PROPER DRAINAGE MUST BE REMOVED AND REPLACED AT THE CONTRACTOR'S EXPENSE.
9. HANDICAP PARKING STALLS SHALL BE PAINTED AND SIGNED IN ACCORDANCE WITH CURRENT ADA STANDARDS AND REGULATIONS.
10. HANDICAP RAMPS SHALL BE CONSTRUCTED IN ACCORDANCE WITH CURRENT ADA STANDARDS AND REGULATIONS.
11. THE FOLLOWING IS APPLICABLE TO ALL CONSTRUCTION WITHIN THE LIMITS OF THIS PROJECT:
 - a. THE MAXIMUM CROSS SLOPE OF ANY SIDEWALK OR PEDESTRIAN ACCESS ROUTE SHALL BE 2.0%. THE SLOPE SHALL BE MEASURED PERPENDICULAR TO THE DIRECTION OF TRAVEL.
 - b. THE GRADE OF HANDICAP PARKING STALLS SHALL NOT EXCEED 2.0% IN ANY DIRECTION. HANDICAP PARKING SHALL HAVE AN ACCESSIBLE ROUTE TO THE BUILDING ENTRY AS SHOWN ON THE DRAWINGS.
 - c. HANDICAP ACCESSIBLE ROUTES SHALL HAVE A MAXIMUM LONGITUDINAL GRADE OF 5.0%. ACCESSIBLE ROUTES EXCEEDING 5.0% SHALL BE CONSTRUCTED WITH RAMPS AND HAND RAILS HAVING A MAXIMUM SLOPE OF 8.33% FOR A MAXIMUM RISE OF 30 INCHES. A 5-FOOT BY 5-FOOT LANDING PAD (WITH A 2 PERCENT MAXIMUM SLOPE IN ANY DIRECTION) SHALL BE CONSTRUCTED AT THE BOTTOM AND TOP OF ALL RAMPS.
12. PRIOR TO PLACEMENT OF CURB AND PAVEMENT CONTRACTOR SHALL VERIFY COMPLIANCE WITH ADA STANDARDS.
13. IF DURING THE GRADING AND CONSTRUCTION PROCESS CONDITIONS ARE ENCOUNTERED BY THE CONTRACTOR, HIS SUBCONTRACTORS, OR OTHER AFFECTED PARTIES WHICH COULD INDICATE A SITUATION THAT IS NOT IDENTIFIED IN THE PLANS OR SPECIFICATIONS, THE CONTRACTOR SHALL CONTACT THE PROJECT MANAGER FOR THE DEVELOPER/OWNER, THE ENGINEER, AND THE GEOTECHNICAL ENGINEER IMMEDIATELY.
14. ALL GRATES, MANHOLE RIMS, VALVE BOXES, VALVE COVERS, CLEANOUTS, AND VAULT OR BOX COVERS SHALL BE ADJUSTED TO "AS CONSTRUCTED" FINISHED GRADE PRIOR TO THE FINAL LIFT OF ASPHALT.
15. ALL CONCRETE PAVEMENT, CONCRETE FLATWORK, CONCRETE STRUCTURES, AND CONCRETE UTILITIES SHALL BE INSTALLED IN ACCORDANCE WITH THE MATERIAL RECOMMENDATIONS OF THE GEOTECHNICAL REPORT PREPARED SPECIFICALLY FOR THIS SITE.
16. CONCRETE PAVEMENT JOINTS SHALL MEET THE REQUIREMENTS OF CDOT STANDARDS AND SPECIFICATIONS, AND CDOT STANDARD PLAN NO. M-412-1, UNLESS NOTED OTHERWISE.
17. ALL SIGNING AND STRIPING WILL BE IN ACCORDANCE WITH THE MANUAL OF UNIFORM TRAFFIC CONTROL DEVICES (MUTCD) AND LOCAL CODES.
18. REFER TO ARCHITECTURAL PLANS FOR BUILDING SIGNAGE LOCATIONS.
19. CONTRACTOR SHALL COORDINATE SIGNAGE PERMIT, INSTALLATION, AND SPECIFICATIONS WITH OWNER AND SIGNAGE MANUFACTURER.
20. CONTRACTOR SHALL VERIFY SIZE AND LOCATION OF ANY AND ALL ALLOWABLE MONUMENT OR POLE SIGNAGE WITH OWNER AND SIGNAGE MANUFACTURER, AND PROVIDE SHOP DRAWINGS PRIOR TO FABRICATION TO THE OWNER FOR APPROVAL.
21. REFER TO THE SITE PLAN FOR EXTENT OF PAVEMENT AND PAVEMENT SECTIONS.
22. GRADES WITHIN ASPHALT PAVING AREAS SHALL BE CONSTRUCTED TO WITHIN 0.10 FEET OF THE DESIGN GRADE. HOWEVER, THE CONTRACTOR SHALL MAINTAIN POSITIVE DRAINAGE IN ALL PAVEMENT AREAS AND ALONG CURBS. CURBS OR PAVEMENT AREAS WHICH DO NOT PROVIDE PROPER DRAINAGE MUST BE REMOVED AND REPLACED AT THE CONTRACTOR'S EXPENSE.
23. THE CONTRACTOR SHALL ASSURE POSITIVE DRAINAGE AWAY FROM BUILDINGS FOR ALL LANDSCAPED AND PAVED AREAS.
24. THE CONTRACTOR SHALL BE RESPONSIBLE FOR THE RESTORATION OF ANY EXISTING IMPROVEMENTS INCLUDING, BUT NOT LIMITED TO STREET PAVEMENT, FENCES, SOD, LANDSCAPING, SPRINKLER SYSTEMS, AND UTILITIES DISTURBED DURING CONSTRUCTION TO THEIR ORIGINAL LOCATION AND CONDITION.
25. IF ANY EXISTING STRUCTURES, SIDEWALK, AND/OR CURB AND GUTTER MODIFIED OR TO REMAIN ARE DAMAGED DURING CONSTRUCTION, IT SHALL BE THE CONTRACTOR'S RESPONSIBILITY TO REPAIR AND/OR REPLACE THE EXISTING STRUCTURE AS NECESSARY TO RETURN IT TO EXISTING CONDITIONS OR BETTER PRIOR TO PROJECT CLOSE OUT.
26. THE CONTRACTOR SHALL PROTECT THE PROJECT BENCHMARK(S) THROUGHOUT CONSTRUCTION AND SET ADDITIONAL PROJECT BENCHMARKS AS NECESSARY TO MAINTAIN VERTICAL CONTROL THROUGHOUT THE DURATION OF THE PROJECT.
27. THE CONTRACTOR SHALL INSPECT AND REPAIR EXISTING DRAINAGE STRUCTURES AS NEEDED, AND CLEAN OUT EXISTING PIPES TO REMOVE ALL SILT AND DEBRIS.

MSE RETAINING WALL GENERAL NOTES

1. CONTRACTOR SHALL PROVIDE FULL DESIGN AND CONSTRUCTION OF THE MSE RETAINING WALLS IN ACCORDANCE WITH ALL APPLICABLE LOCAL, STATE, AND INDUSTRY STANDARDS AND SPECIFICATIONS.
2. THE ALIGNMENT OF THE MSE WALLS IS SHOWN ON THE PLANS AND ASSOCIATED PROFILES DEPICTING THE FINISHED GRADE AT THE TOP OF THE WALL (TOW) AND BOTTOM OF THE WALL (BOW) AND IS NOT INTENDED TO SHOW ANY PORTION OF THE WALL BELOW FINISHED GRADE. CHANGES IN THE TOP OF WALL ELEVATIONS SHALL BE ACHIEVED BY UNIFORMLY STEPPING THE WALL.
3. CONTRACTOR IS REQUIRED TO:
 - a. REVIEW THE GEOTECHNICAL REPORT FOR THE SITE AND VERIFY THE REPORT PROVIDES ALL INFORMATION REQUIRED FOR THE DESIGN OF THE WALL.
 - b. PROVIDE FULL DESIGN OF THE WALL INCLUDING DESIGN CALCULATIONS AND CONSTRUCTION DRAWINGS PREPARED BY A LICENSED ENGINEER TO BE SUBMITTED TO THE CITY FOR APPROVAL. THE DESIGN SHALL CONSIDER THE LONG TERM STRUCTURAL STABILITY OF THE WALL AND ADDRESS DRAINAGE BEHIND THE WALL.
 - c. OBTAIN ALL PERMITS REQUIRED FOR THE WORK.
 - d. VERIFY EXISTING AND PROPOSED ELEVATIONS AT TOP OF WALL.
 - e. PROVIDE ALL MATERIALS AND LABOR REQUIRED FOR CONSTRUCTION AND INSTALLATION OF THE WALL.
 - f. PROVIDE MATERIAL TESTING OF ALL MATERIALS USED FOR CONSTRUCTION OF WALLS.
 - g. DETAIL, PROVIDE, AND INSTALL A PEDESTRIAN GUARDRAIL ALONG THE TOP OF ALL WALLS INSTALLED. SUBMIT DETAILS TO THE ARCHITECT FOR APPROVAL PRIOR TO INSTALLATION.
 - h. SUBMIT TO THE ARCHITECT A COLOR AND TEXTURE SAMPLE OF THE BLOCK TO BE USED PRIOR TO INSTALLATION.



Know what's Below. Call before you dig.
 THE LOCATIONS OF EXISTING UNDERGROUND UTILITIES ARE SHOWN BY AN APPROXIMATE WAY ONLY AND HAVE NOT BEEN INDEPENDENTLY VERIFIED BY THE OWNER OR ITS REPRESENTATIVE. THE CONTRACTOR SHALL DETERMINE THE EXACT LOCATION OF ALL EXISTING UTILITIES BEFORE COMMENCING WORK, AND AGREES TO BE FULLY RESPONSIBLE FOR ANY AND ALL DAMAGES WHICH MIGHT BE OCCURRED BY THE CONTRACTOR'S FAILURE TO LOCATE AND PRESERVE ANY AND ALL UNDERGROUND UTILITIES.

NOTICE:
 CONSTRUCTION SITE SAFETY IS THE SOLE RESPONSIBILITY OF THE CONTRACTOR. NEITHER THE OWNER NOR THE ENGINEER SHALL BE HELD RESPONSIBLE FOR ANY PERSONS ENGAGED IN THE WORK OF ANY OTHER PERSONS.

COPYRIGHT: © 2025 ATWELL LLC. NO REPRODUCTION SHALL BE MADE WITHOUT THE PRIOR WRITTEN CONSENT OF ATWELL LLC.



ATWELL
 866.850.4200 www.atwell-group.com
 9001 AIRPORT FREEWAY, SUITE 660
 NORTH RICHLAND HILLS, TX 76180
 972.356.9560

LOT 4A, PARKER POINT SUBD. FILING NO. 1, AMEND. NO. 1
S. PARKER RD & STROH RD
PARKER
DOUGLAS COUNTY, COLORADO

BLACK ROCK COFFEE BAR
 13135 DECLAN DRIVE
BLACK ROCK COFFEE BAR
 GENERAL NOTES

DATE 2025-08-25

REVISIONS

DRAWN BY: K. SARWAR
 CHECKED BY: N. SALAZAR
 PROJECT MANAGER: N. SALAZAR
 JOB #: 24003198
 FILE CODE: ##
 SHEET NO. C1.20

FILE NAME: \\fiona\c\p\24003198 - BIC - Parker.ctb; PLOT DATE: 8/14/2025 4:55 PM; PLOTTED BY: Douglas_Sarwar; PLOTTER: HP DesignJet 2400; PLOT SCALE: 1.00; PLOT SHEET: ATWELL-28

CAD FILE: 24003198 - C100 NOTES

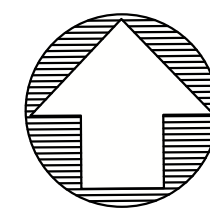

Know what's below. Call before you dig.
 THE LOCATIONS OF EXISTING UNDERGROUND UTILITIES ARE SHOWN BY AN APPROXIMATE WAY ONLY AND HAVE NOT BEEN INDEPENDENTLY VERIFIED BY THE OWNER OR ITS REPRESENTATIVE. THE CONTRACTOR SHALL DETERMINE THE EXACT LOCATION OF ALL EXISTING UTILITIES BEFORE COMMENCING WORK AND AGREES TO BE FULLY RESPONSIBLE FOR ANY AND ALL DAMAGES WHICH MIGHT BE OCCURRED BY THE CONTRACTOR'S FAILURE TO LOCATE AND PRESERVE ANY AND ALL UNDERGROUND UTILITIES.

NOTICE:
 CONSTRUCTION SITE SAFETY IS THE SOLE RESPONSIBILITY OF THE CONTRACTOR. NEITHER THE OWNER NOR THE ENGINEER SHALL BE HELD RESPONSIBLE FOR ANY INJURY OR DAMAGE TO PERSONS OR PROPERTY OF ANY KIND ARISING FROM THE WORK OF ANY NEARBY STRUCTURES, OR OF ANY OTHER PERSONS.

COPYRIGHT: © 2025 ATWELL LLC. NO REPRODUCTION SHALL BE MADE WITHOUT THE PRIOR WRITTEN CONSENT OF ATWELL LLC.

ATWELL
 866.850.4200 www.atwell-group.com
 9001 AIRPORT FREEWAY, SUITE 660
 NORTH RICHLAND HILLS, TX 76180
 972.636.6660



LOT 4A, PARKER POINT SUBD. FILING NO. 1, AMEND. NO. 1

BLACK ROCK COFFEE BAR
 13135 DECLAN DRIVE
 S. PARKER RD & STROH RD

PARKER

DOUGLAS COUNTY, COLORADO

DATE 2025-08-25

REVISIONS

REVISIONS

REVISIONS

REVISIONS

REVISIONS

REVISIONS

REVISIONS

REVISIONS

REVISIONS

REVISIONS

REVISIONS

REVISIONS

REVISIONS

SITE LEGEND

- EXISTING PROPERTY LINE
- EXISTING ROAD CENTERLINE
- EXISTING EASEMENT LINE
- 6" CURB
- ♿ HANDICAP STALL
- ♿ A.D.A. STD HANDICAP RAMP
- Ⓜ PARKING SPACE COUNT
- Ⓜ # OF STACKING
- ▭ VEHICLE STACKING SPACE
- Ⓜ SIGN

CORRESPONDING DETAIL NUMBER (SEE DETAIL SHEETS)

NOTE NUMBER

- | | | |
|----|--|---------------------------------------|
| 1 | INSTALL 2" AC PAVEMENT OVER 10" AGGREGATE BASE (PER GEOTECH REPORT) | C700 |
| 2 | PROPOSED PICK-UP WINDOW WITH COUNTER | SEE ARCHITECTURAL PLANS FOR DETAILS |
| 3 | PROPOSED LANDSCAPE | SEE LANDSCAPE PLANS FOR DETAILS |
| 4 | 4" WIDE PAINTED WHITE TRAFFIC STRIPE (SEE LENGTH THIS SHEET) | - |
| 5 | CONSTRUCT 6" SINGLE CURB | - |
| 6 | DUMPSTER ENCLOSURE | - |
| 7 | INSTALL ADA CROSSWALK | - |
| 8 | 4" WIDE PAINTED STRIPE @ 2' O.C. AND 45 DEGREES | - |
| 9 | CONSTRUCT DIRECTIONAL CURB RAMP PER PARKER STANDARD DETAIL #18. | C700 |
| 10 | CONSTRUCT SIDEWALK PER PARKER STANDARD DETAIL #4 | C700 |
| 11 | ADA PARKING STALL WITH ADA SYMBOL AND REQUIRED PAINT. | - |
| 12 | PROTECT EXISTING UTILITIES IN PLACE. | - |
| 13 | INSTALL 3 1/2" AC OVER 10" AGGREGATE BASE (PER GEOTECH REPORT) | C700 |
| 14 | MATCH EXISTING ASPHALT ALONG DECLAN DRIVE PER PARKER STANDARD DETAIL #26 | C700 |
| 15 | INSTALL 5" CURB INLET | C700 |
| 16 | PROPOSED STORM MANHOLE | C700 |
| 17 | EXISTING UTILITIES TO BE RELOCATED | - |
| 18 | EXISTING 8" CONCRETE SIDEWALK | - |
| 19 | PROPOSED 10' X 10' TRANSFORMER PAD | - |
| 20 | 7" PORTLAND CEMENT CONCRETE OVER 8" AGGREGATE BASE (PER GEOTECH REPORT) | C700 |
| 21 | PROPOSED SIGN "NO PARKING - FIRE LANE" | - |
| 22 | PROPOSED SCREEN WALL | SEE ARCHITECTURAL PLANS FOR DETAILS |
| 23 | PROPOSED AREA LIGHT | SEE PHOTOMETRIC SITE PLAN FOR DETAILS |

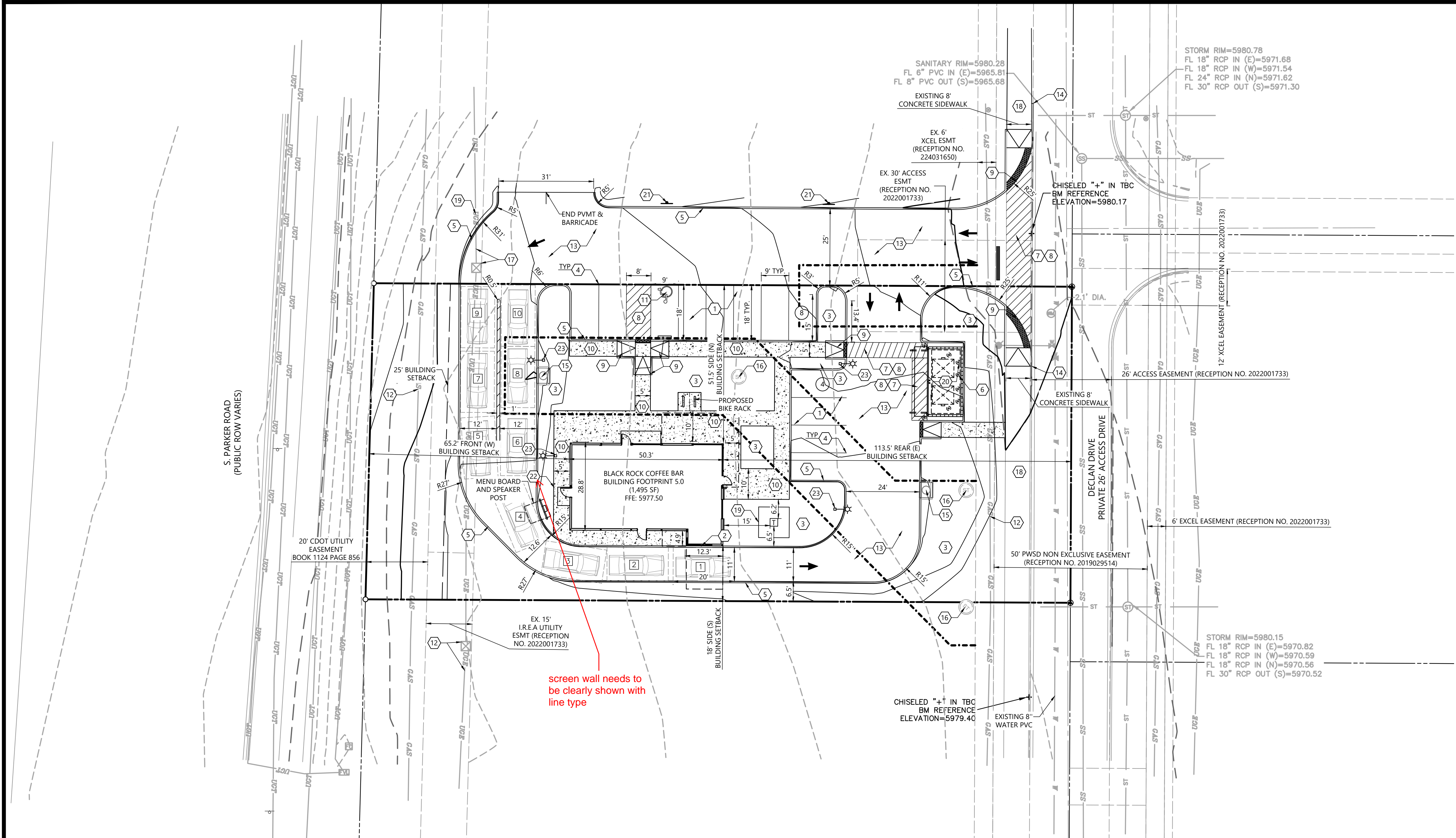

screen wall needs to be clearly shown with line type

SITE GENERAL NOTES:

1. DIMENSIONS SHOWN ARE TO THE FACE OF CURB, UNLESS OTHERWISE INDICATED.
2. USE 3' RADIUS, UNLESS SHOWN OTHERWISE.
3. THE INFORMATION PERTAINING TO EXISTING CONDITIONS WAS TAKEN FROM A SURVEY PROVIDED BY: BARRON LAND. THE LOCATION OF ALL EXISTING UTILITIES WERE OBTAINED FROM AVAILABLE INFORMATION. THE CONTRACTOR SHALL VERIFY EXACT LOCATION AND DEPTH OF UTILITY PRIOR TO BEGINNING CONSTRUCTION. CONTRACTOR SHALL NOTIFY THE ENGINEER OF ANY DISCREPANCIES.
4. ALL ACCESSIBLE PARKING SPACES AND TRAVEL ROUTES SHALL BE CONSTRUCTED IN ACCORDANCE WITH A.D.A. AND/OR STATE REQUIREMENTS.
5. ANY DISCREPANCIES IN THIS PLAN AND ACTUAL FIELD CONDITIONS SHALL BE REPORTED TO THE OWNER AND ENGINEER PRIOR TO THE START OF CONSTRUCTION.
6. PRIOR TO STARTING CONSTRUCTION, THE GENERAL CONTRACTOR SHALL BE RESPONSIBLE TO VERIFY THAT ALL REQUIRED PERMITS AND APPROVALS HAVE BEEN OBTAINED. NO CONSTRUCTION SHALL BEGIN UNTIL ALL PERMITS HAVE BEEN RECEIVED.
7. CONTRACTOR SHALL MAINTAIN THE SITE IN A MANNER SO THAT WORKERS AND PUBLIC SHALL BE PROTECTED FROM INJURY, AND ADJOINING PROPERTY PROTECTED FROM DAMAGE. CONTRACTOR SHALL REPAIR ANY DAMAGE DONE TO PRIVATE OR PUBLIC PROPERTY.
8. ACCESS TO UTILITIES, FIRE HYDRANTS, ETC. SHALL REMAIN UNDISTURBED AT ALL TIMES, UNLESS COORDINATED OTHERWISE.
9. THE GENERAL CONTRACTOR SHALL REMOVE ALL TRASH AND DEBRIS FROM THE SITE UPON COMPLETION OF THE PROJECT.
10. ALL SUBGRADE PREPARATION, PAVING, AND UTILITY TRENCHING MUST BE IN ACCORDANCE WITH THE RECOMMENDATIONS OF THE SOILS INVESTIGATION. IF THERE IS A CONFLICT BETWEEN THE SOILS REPORT AND THE PLANS, THE MORE PROHIBITIVE OF THE TWO SHALL TAKE PRECEDENCE.
11. CONTRACTOR TO ENSURE COMPLIANCE WITH ANY AND ALL LAND DISTURBANCE NOTIFICATIONS REQUIREMENTS, AND THAT ALL REQUIRED EROSION CONTROL MEASURES ARE INSTALLED AND MAINTAINED IN ACCORDANCE WITH LOCAL, STATE, AND FEDERAL REQUIREMENTS.
12. FOR WORK IN, OR ADJACENT TO, STREET RIGHT OF WAYS, CONTRACTOR SHALL ENSURE APPROPRIATE PERMITS ARE OBTAINED PRIOR TO CONSTRUCTION. CONTRACTOR TO ERECT AND MAINTAIN TRAFFIC CONTROL SIGNS AND DEVICES IN CONFORMANCE WITH THE REQUIREMENTS OF THE AUTHORITY HAVING JURISDICTION.
13. ALL PARKING LOT LIGHTING MUST BE INSTALLED AND OPERATE SO AS NOT TO PRODUCE GLARE OR CAST DIRECT ILLUMINATION ACROSS THE BOUNDING PROPERTY LINE. LOW PRESSURE SODIUM LIGHTING IS PROHIBITED. ALL LIGHTING FIXTURES MUST BE RESTRICTED TO DOWN-LIGHT OR CUT-OFF TYPES.

CALL UTILITY NOTIFICATION
 CENTER OF COLORADO
 1-800-922-1987
 CALL 2-BUSINESS DAYS IN ADVANCE
 BEFORE YOU DIG, GRADE, OR EXCAVATE
 FOR THE MARKING OF UNDERGROUND
 MEMBER UTILITIES.

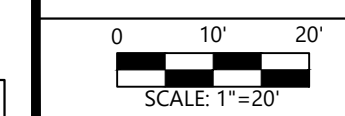

DRAWN BY: K. SARWAR
 CHECKED BY: N. SALAZAR
 PROJECT MANAGER: N. SALAZAR
 JOB #: 24003198
 FILE CODE: ##
 SHEET NO. C2.00

TOWN OF PARKER STANDARD DETAILS

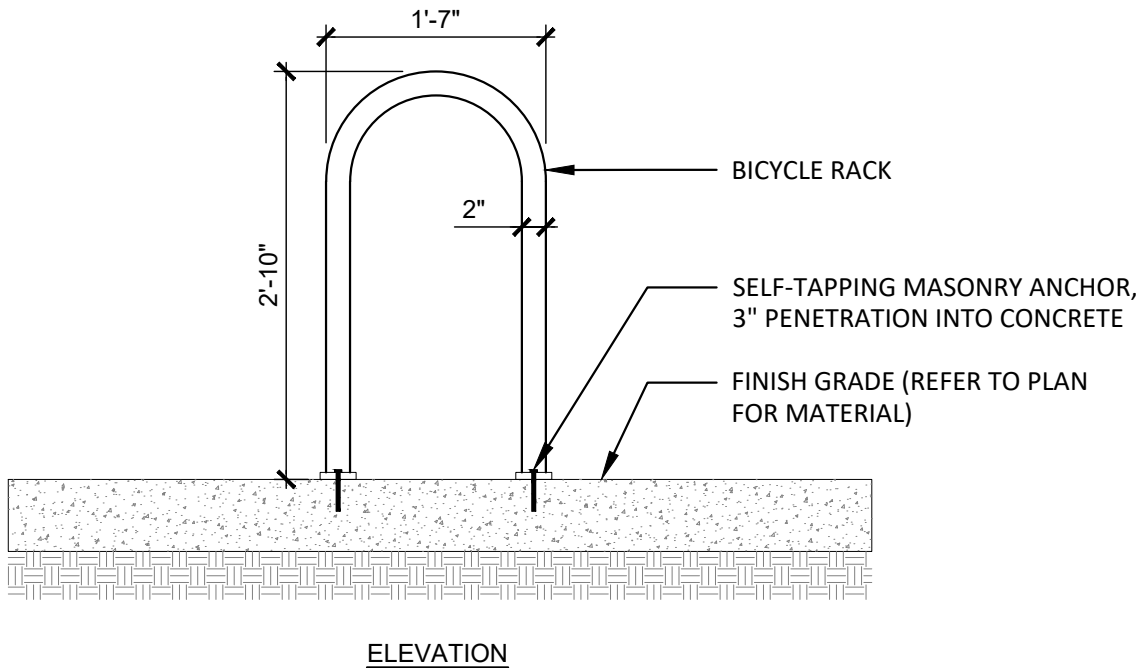
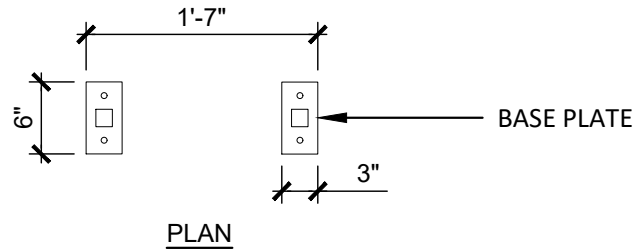

NOTES:

1. BASIS-OF-DESIGN: BIKE RACK (MADRAX U-200), SURFACE MOUNTED, COLOR: BLACK
2. FINAL LOCATION TO BE VERIFIED IN FIELD WITH OWNER AND DESIGN TEAM COORDINATE WITH OWNER ON EXACT LOCATION.
3. WHERE BICYCLE RACK SITS ON UNIT PAVING, MASONRY ANCHOR TO EXTEND THROUGH UNIT PAVING AND EMBED INTO C.I.P. CONCRETE FOOTING TO MIN. 3" DEPTH.



SECTION 32 9300 - LANDSCAPE

PART 1 - GENERAL

1.1 QUALIFICATIONS OF THE LANDSCAPE CONTRACTOR

A. ALL LANDSCAPE PLANS SHALL BE PERFORMED BY A SINGLE FIRM SPECIALIZING IN LANDSCAPE PLANNING

1.2 REFERENCE DOCUMENTS

A. REFER TO LANDSCAPE PLANS, NOTES, SCHEDULES AND DETAILS FOR ADDITIONAL REQUIREMENTS

1.3 SCOPE OF WORK / DESCRIPTION OF WORK

A. WORK COVERED BY THESE SECTIONS INCLUDES: FURNISH ALL SUPERVISORS, LABOR, MATERIALS, SERVICES, EQUIPMENT AND APPLIANCES REQUIRED TO COMPLETE THE WORK COVERED IN CONJUNCTION WITH THE LANDSCAPING COVERED IN LANDSCAPE PLANS AND SPECIFICATIONS INCLUDING:

- PLANTING (TREES, SHRUBS, GRASSES)
- BED PREP AND FERTILIZATION
- NOTIFICATION OF SOURCES
- WATER AND MAINTENANCE UNTIL ACCEPTANCE

B. ALL WORK SHALL BE PERFORMED IN ACCORDANCE WITH ALL APPLICABLE LAWS, CODES AND REGULATIONS REQUIRED BY AUTHORITIES HAVING JURISDICTION OVER SUCH WORK, INCLUDING ALL INSPECTIONS AND PERMITS REQUIRED BY FEDERAL, STATE AND LOCAL AUTHORITIES IN SUPPLY, TRANSPORTATION AND INSTALLATION OF MATERIALS.

C. THE LANDSCAPE CONTRACTOR SHALL VERIFY THE LOCATION OF ALL UNDERGROUND UTILITY LINES (WATER, SEWER, ELECTRICAL, TELEPHONE, GAS, CABLE, TELEVISION, ETC.) PRIOR TO THE START OF ANY WORK

1.4 REFERENCES

- AMERICAN STANDARD FOR NURSERY STOCK PUBLISHED BY AMERICAN ASSOCIATION OF NURSERMEN, 27 OCTOBER 1989, EDITION; BY AMERICAN NATIONAL STANDARDS INSTITUTE (206.1) - PLANT MATERIAL
- AMERICAN JOINT COMMITTEE ON HORTICULTURE NOMENCLATURE, 1942 EDITION OF STANDARDIZED PLANT NAMES
- TEXAS ASSOCIATION OF NURSERMEN, GRADES AND STANDARDS

1.5 SUBMITTALS

- PROVIDE REPRESENTATIVE QUANTITIES OF EACH SOIL, MULCH, BED MIX, GRAVEL AND STONE BEFORE INSTALLATION. SAMPLES TO BE APPROVED BY OWNERS REPRESENTATIVE BEFORE USE.
- SOIL AMENDMENTS AND FERTILIZERS SHOULD BE RESEARCHED AND BASED ON THE SOILS IN THE AREA.
- BEFORE INSTALLATION, SUBMIT DOCUMENTATION THAT PLANT MATERIALS ARE AVAILABLE AND HAVE BEEN RESERVED. FOR ANY PLANT MATERIAL NOT AVAILABLE, SUBMIT REQUEST FOR SUBSTITUTION.

B. GENERAL CONTRACTOR TO COMPLETE WORK BEFORE LANDSCAPE CONTRACTOR TO COMMENCE.

C. BEFORE INSTALLATION, SUBMIT DOCUMENTATION THAT PLANT MATERIALS ARE AVAILABLE AND HAVE BEEN RESERVED. FOR ANY PLANT MATERIAL NOT AVAILABLE, SUBMIT REQUEST FOR SUBSTITUTION.

D. STORAGE OF MATERIALS AND EQUIPMENT AT THE JOB SITE WILL BE AT THE RISK OF THE LANDSCAPE CONTRACTOR. THE OWNER CANNOT BE HELD RESPONSIBLE FOR THEFT OR DAMAGE.

1.7 SEQUENCING

A. INSTALL TREES, SHRUBS, AND LINER STOCK PLANT MATERIALS PRIOR TO INSTALLATION OF LAWN/SOD/SOD.

B. WHERE EXISTING TURF AREAS ARE BEING CONVERTED TO PLANTING BEDS, THE TURF SHALL BE CHEMICALLY ERADICATED TO MINIMIZE RE-GROWTH IN THE FUTURE. AREAS SHALL BE PROPERLY PREPARED WITH AMENDED ORGANIC MATTER.

1.8 MAINTENANCE AND GUARANTEE

A. THE LANDSCAPE CONTRACTOR SHALL BE HELD RESPONSIBLE FOR THE MAINTENANCE OF ALL WORK FROM THE TIME OF PLANTING UNTIL FINAL ACCEPTANCE BY OWNER.

B. NO TREES, GRASS, GROUNDCOVER OR GRASS WILL BE ACCEPTED UNLESS THEY SHOW HEALTHY GROWTH AND SATISFACTORY FOLIAGE CONDITIONS.

C. MAINTENANCE SHALL INCLUDE WATERING OF TREES AND PLANTS, CULTIVATING, WEED SPRAYING, EDGING, PRUNING OF TREES, MOVING OF GRASS, CLEANING UP AND ALL OTHER WORK NECESSARY FOR MAINTENANCE.

D. A WRITTEN NOTICE REQUESTING FINAL INSPECTION AND ACCEPTANCE SHOULD BE SUBMITTED TO THE OWNER AT LEAST 7 DAYS PRIOR TO COMPLETION. AN ON SITE INSPECTION BY THE OWNERS AUTHORIZED REPRESENTATIVE WILL BE COMPLETED PRIOR TO WRITTEN ACCEPTANCE.

E. NOTIFY OWNER OR OWNERS REPRESENTATIVE SEVEN DAYS PRIOR TO THE EXPIRATION OF THE WARRANTY PERIOD.

F. REMOVE DEAD, UNHEALTHY AND UNSIGHTLY PLANTS DURING WARRANTY PERIOD.

G. REMOVE GRASS AND STAKING MATERIALS AFTER ONE YEAR.

H. ALL LANDSCAPE MUST BE MAINTAINED AND GRASS MOWED/EDGED ON A WEEKLY SCHEDULE UNTIL ACCEPTANCE BY OWNER. REMOVE CLIPPINGS AND DEBRIS FROM SITE PROMPTLY.

I. REMOVE TRASH, DEBRIS, AND LITTER, WATER, PRUNE, RESTAKE TREES, FERTILIZE, WEED AND APPLY HERBICIDES AS REQUIRED.

J. COORDINATE THE OPERATION OF IRRIGATION SYSTEM TO ENSURE THAT PLANTS ARE ADEQUATELY WATERED. HAD WATER AREAS NOT RECEIVING ADEQUATE WATER FROM AN IRRIGATION SYSTEM.

K. THE LANDSCAPE CONTRACTOR SHALL MAINTAIN THE IRRIGATION SYSTEM IN ACCORDANCE TO THE MAINTENANCE SCHEDULE TO ENSURE THE SYSTEM IS IN PROPER WORKING ORDER WITH SCHEDULING ADJUSTMENTS BY SEASON TO MAXIMIZE WATER CONSERVATION.

L. REAPPLY MULCH TO BARE AND THIN AREAS.

M. SHOULD SEEDED AND/OR SODDED AREAS NOT BE COVERED BY AN AUTOMATIC IRRIGATION SYSTEM, THE LANDSCAPE CONTRACTOR SHALL BE RESPONSIBLE FOR WATERING THESE AREAS AND OBTAINING A FULL, HEALTHY STAND OF GRASS AT NO ADDITIONAL COST TO THE OWNER.

N. TO ACHIEVE FINAL ACCEPTANCE AT THE END OF THE MAINTENANCE PERIOD, ALL OF THE FOLLOWING CONDITIONS MUST OCCUR:

- THE LANDSCAPE SHALL SHOW ACTIVE, HEALTHY GROWTH (WITH EXCEPTIONS MADE FOR SEASONAL DORMANCY). ALL PLANTS NOT MEETING THIS CONDITION SHALL BE REJECTED AND REPLACED BY HEALTHY PLANT MATERIAL PRIOR TO FINAL ACCEPTANCE.
- ALL HARDSCAPE SHALL BE CLEANED PRIOR TO FINAL ACCEPTANCE.
- SODDED AREAS MUST BE ACTIVELY GROWING AND MUST REACH A MINIMUM HEIGHT OF 3" TO 1 1/2" INCHES BEFORE FIRST MOWING. HYDROMULCHED AREAS SHALL SHOW ACTIVE, HEALTHY GROWTH. BARE AREAS LARGER THAN TWELVE SQUARE INCHES MUST BE RESODDED OR RESEEDED (AS APPROPRIATE) PRIOR TO FINAL ACCEPTANCE. ALL SODDED TURF SHALL BE NEATLY MOWED.

GUARANTEE:

A. TREES, SHRUBS, GROUNDCOVER SHALL BE GUARANTEED (IN WRITING) FOR A 12 MONTH PERIOD (90 DAYS FOR ANNUAL PLANTING OR AT THE END OF THE SEASONAL COLOR GROWING SEASON, WHICHEVER COMES SOONER) AFTER FINAL ACCEPTANCE. THE CONTRACTOR SHALL REPLACE ALL DEAD MATERIALS AS SOON AS WEATHER PERMITS AND UPON NOTIFICATION OF THE OWNER.

B. PLANTS INCLUDING TREES, WHICH HAVE PARTIALLY DIED SO THAT SHAPE, SIZE OR SYMMETRY HAVE BEEN DAMAGED SHALL BE CONSIDERED SUBJECT TO REPLACEMENT. IN SUCH CASES, THE OPINION OF THE OWNER SHALL BE FINAL.

C. PLANTS USED FOR REPLACEMENT SHALL BE OF THE SAME SIZE AND KIND AS THOSE ORIGINALLY PLANTED OR SPECIFIED. ALL WORK INCLUDING MATERIALS, LABOR AND EQUIPMENT USED IN REPLACEMENTS SHALL CARRY A 12 MONTH GUARANTEE. ANY DAMAGE INCLUDING RUTS IN LAWN OR BED AREAS INCURRED AS A RESULT OF MAKING REPLACEMENTS SHALL BE IMMEDIATELY REPAIRED.

D. WHEN PLANT REPLACEMENTS ARE MADE, PLANTS, SOIL MIX, FERTILIZER AND MULCH ARE TO BE UTILIZED AS ORIGINALLY SPECIFIED AND RE-INSPECTED FOR FULL COMPLIANCE WITH THE CONTRACT REQUIREMENTS. ALL REPLACEMENTS ARE INCLUDED UNDER "WORK" OF THIS SECTION.

E. THE OWNER AGREES THAT FOR THE ONE YEAR WARRANTY PERIOD TO BE EFFECTIVE, HE WILL WATER PLANTS AT LEAST TWICE A WEEK DURING DRY PERIODS.

F. THE ABOVE GUARANTEE SHALL NOT APPLY WHERE PLANTS DIE AFTER ACCEPTANCE BECAUSE OF DAMAGE DUE TO ACTS OF GOD, VANDALISM, INSECTS, DISEASE, INJURY BY HUMANS, MACHINES, THEFT OR NEGLIGENCE BY OWNER.

G. ACCEPTANCE FOR ALL LANDSCAPE WORK SHALL BE GIVEN AFTER FINAL INSPECTION BY THE OWNER PROVIDED THE JOB IS IN A COMPLETE UNDAMAGED CONDITION AND THERE IS A STAND OF GRASS IN ALL LAWN AREAS. AT THAT TIME, THE OWNER WILL ASSUME MAINTENANCE ON THE ACCEPTED WORK.

1.9 QUALITY ASSURANCE

A. COMPLY WITH ALL FEDERAL, STATE, COUNTY AND LOCAL REGULATIONS GOVERNING LANDSCAPE MATERIALS AND WORK.

B. EMPLOY PERSONNEL EXPERIENCED AND FAMILIAR WITH THE REQUIRED WORK AND SUPERVISION BY A FOREMAN.

C. MAKE CONTACT WITH SUPPLIERS IMMEDIATELY UPON OBTAINING NOTICE

OF CONTRACT ACCEPTANCE TO SELECT AND BOOK MATERIALS.

D. DEVELOP A PROGRAM OF MAINTENANCE (PRUNING AND FERTILIZATION) WHICH WILL ENSURE THE PURCHASED MATERIALS WILL MEET AND/OR EXCEED PROJECT SPECIFICATIONS.

E. DO NOT MAKE PLANT MATERIAL SUBSTITUTIONS IF THE LANDSCAPE MATERIAL SPECIFIED IS NOT READILY AVAILABLE, SUBMIT PROOF TO LANDSCAPE ARCHITECT ALONG WITH THE PROPOSED MATERIAL TO BE USED IN LIEU OF THE SPECIFIED PLANT.

F. AT THE TIME BIDS ARE SUBMITTED, THE CONTRACTOR IS ASSUMED TO HAVE LOCATED THE MATERIALS NECESSARY TO COMPLETE THE JOB AS SPECIFIED.

G. OWNERS REPRESENTATIVE SHALL INSPECT ALL PLANT MATERIAL AND RETAINS THE RIGHT TO INSPECT MATERIALS UPON ARRIVAL TO THE SITE AND DURING INSTALLATION. THE OWNERS REPRESENTATIVE HAS THE RIGHT TO REJECT ANY MATERIALS HE/SHE FEELS TO BE UNSATISFACTORY OR DEFECTIVE DURING THE WORK PROCESS. ALL PLANTS DAMAGED IN TRANSIT OR AT THE JOB SITE SHALL BE REJECTED.

H. CONTRACTOR SHALL DELIVER, STORE AND HANDLING

A. PREPARATION

1. BALLED AND BURLAPPED 888 PLANTS; DIG AND PREPARE SHIPMENT IN A MANNER THAT WILL NOT DAMAGE ROOTS, BRANCHES, SHAPE AND FUTURE DEVELOPMENT.

2. CONTAINER GROWN PLANTS: DELIVER PLANTS IN RIGID CONTAINER TO HOLD BALL SHAPE AND PROTECT ROOT MASS.

B. DELIVERY

1. DELIVER PACKAGED MATERIALS IN SEALED CONTAINERS SHOWING WEIGHT, ANALYSIS AND NAME OF MANUFACTURER. PROTECT MATERIALS FROM DECONTAMINATION DURING DELIVERY AND WHILE STORED ON SITE.

2. DELIVER ONLY PLANT MATERIALS THAT MEET ALL CONSTRUCTION REQUIREMENTS UNLESS ADEQUATE STORAGE AND WATERING FACILITIES ARE AVAILABLE ON SITE.

3. PROTECT ROOT BALLS BY HEELING IN WITH SAWDUST OR OTHER APPROVED MOISTURE RETAINING MATERIAL IF NOT PLANTED WITHIN 24 HOURS OF DELIVERY.

4. PROTECT PLANTS DURING DELIVERY TO PREVENT DAMAGE TO ROOT BALL OR DECONTAMINATION OF LEAVES.

5. KEEP PLANTS MOIST AT ALL TIMES. COVER ALL MATERIALS DURING TRANSPORT.

6. NOTIFY OWNERS REPRESENTATIVE OF DELIVERY 72 HOURS PRIOR TO DELIVERY PLANT MATERIAL AT JOB SITE.

7. REMOVE REJECTED PLANT MATERIAL IMMEDIATELY FROM JOB SITE.

8. TO AVOID DAMAGE OR STRESS, DO NOT LIFT, MOVE, ADJUST TO PLUMBS, OR OTHERWISE MANIPULATE PLANTS BY TRUNK OR STEMS.

PART 2 - PRODUCTS

2.1 PLANT MATERIALS

A. GENERAL: WELL FORMED NO. 1 GRADE OR BETTER NURSERY GROWN STOCK LISTED PLANT HEIGHTS ABOVE PLANT TOPS OF FOOT BALLS TO NOMINAL TOPS OF PLANTS. PLANT SPREAD REFERS TO NOMINAL OUTER WIDTH OF THE PLANT NOT THE OUTER LEAF TIPS. PLANTS SHALL BE INDIVIDUALLY APPROVED BY THE OWNERS REPRESENTATIVE AND THEIR DECISION AS TO THEIR ACCEPTABILITY SHALL BE FINAL.

B. QUANTITIES: THE DRAWINGS AND SPECIFICATIONS ARE COMPLIMENTARY. ANYTHING CALLED FOR ON ONE AND NOT THE OTHER IS AS SHOWN AND CALLED FOR ON BOTH. THE PLANT SCHEDULE IS AN AID TO BIDDERS ONLY. CONFIRM ALL QUANTITIES ON THE PLAN.

C. QUANTITIES AND SIZE: PLANT MATERIALS SHALL CONFORM TO THE SIZE GIVEN ON THE PLAN AND SHALL BE HEALTHY, WELL SHAPED, FULL BRANCHED AND WELL ROOTED. SYMMETRY IS ALSO IMPERATIVE. PLANTS SHALL BE FREE FROM INSECTS, INJURY, DISEASE, BROKEN BRANCHES, DISFIGUREMENTS, INSECT EGGS AND ARE TO BE OF SPECIMEN QUALITY.

D. APPROVAL: ALL PLANTS WHICH ARE FOUND UNSUITABLE IN GROWTH OR ARE UNHEALTHY, BADLY SHAPED OR UNDERSIZED WILL BE REJECTED BY THE OWNERS REPRESENTATIVE EITHER BEFORE OR AFTER PLANTING AND SHALL BE REMOVED AT THE EXPENSE OF THE LANDSCAPE CONTRACTOR AND REPLACED WITH ACCEPTABLE SPECIMENS.

E. TREES SHALL BE HEALTHY, FULL BRANCHED, WELL SHAPED AND SHALL MEET THE MINIMUM REQUIREMENTS AS SPECIFIED ON THE PLANT SCHEDULE. ALL TREES SHALL BE OBTAINED FROM SOURCES WITHIN 200 MILES OF THE PROJECT SITE IF POSSIBLE, AND WITH SIMILAR CLIMATIC CONDITIONS.

F. PRUNING: ALL PRUNING OF TREES AND SHRUBS SHALL BE EXECUTED BY THE LANDSCAPE CONTRACTOR AT NO ADDITIONAL COST TO THE OWNER, PRIOR TO FINAL ACCEPTANCE.

G. PLANTS SHALL CONFORM TO THE MEASUREMENTS SPECIFIED EXCEPT THE PLANTS LARGER THAN THOSE SPECIFIED MAY BE USED. USE OF LARGER PLANTS SHALL NOT INCREASE THE CONTRACT PRICE.

H. WHERE MATERIALS ARE PLANTED IN MASSES, PROVIDE PLANTS OF UNIFORM SIZE.

I. ROOT SYSTEMS SHALL BE HEALTHY, DENSELY BRANCHED, VIGOROUS ROOT SYSTEMS, NON-POT-BOUND, FREE FROM ENCRUSTING AND/OR GRINDING ROOTS, AND FREE FROM ANY OTHER ROOT DISEASES (SUCH AS L-SHAPED ROOTS).

J. ALL TREES SHALL BE STANDARD IN FORM, UNLESS OTHERWISE SPECIFIED. TREES WITH CENTRAL LEADERS WILL NOT BE ACCEPTED IF LEADER IS DAMAGED OR REMOVED. PRUNE ALL DAMAGED TWIGS AFTER PLANTING.

K. TREE TRUNKS TO BE STURDY, EXHIBIT HARDENED SYSTEMS AND VIGOROUS AND FIBROUS ROOT SYSTEMS. TRUNKS SHOULD BE PROTECTED FROM DAMAGE BY TREES WITH DAMAGED OR CROOKED LEADERS, BARK ABRASIONS, SUNKALC, DISFIGURING KNOTS, OR INSECT DAMAGE WILL BE REJECTED.

L. CALIPER MEASUREMENTS FOR STANDARD (SINGLE TRUNK) TREES SHALL BE AS FOLLOWS: SIX INCHES ABOVE THE ROOT FLARE FOR TREES UP TO AND INCLUDING FOUR INCHES IN CALIPER, AND TWELVE INCHES ABOVE THE ROOT FLARE FOR TREES EXCEEDING FOUR INCHES IN CALIPER.

M. MULTITRUNK TREES SHALL BE MEASURED BY THEIR OVERALL HEIGHT, MEASURED FROM THE TOP OF THE ROOT BALL.

N. ANY TREE OR SHRUB SHOWN TO HAVE EXCESS SOIL PLACED ON TOP OF THE ROOT BALL, SO THAT THE ROOT FLARE HAS BEEN COMPLETELY COVERED, SHALL BE REJECTED.

O. SOD: PROVIDE WELL-ROOTED SOD OF THE VARIETY NOTED ON THE PLAN. SOD SHALL BE CUT FROM HEALTHY, MATURE TURF WITH SOIL THICKNESS OF 3/4" TO 1". EACH PALLET OF SOD SHALL BE ACCOMPANIED BY A CERTIFICATE FROM SUPPLIER STATING THE COMPOSITION OF THE SOD.

2.2 SOIL PREPARATION MATERIALS

A. SANDY LOAM:

1. FRIABLE, FERTILE, DARK, LOAMY SOIL, FREE OF CLAY LUMPS, SUBSOIL, STONES AND OTHER EXTRANEOUS MATERIAL AND REASONABLY FREE OF WEEDS AND FOREIGN GRASSES. LOAM CONTAINING DALLAS SOIL OR NATURAL GRASS SHALL BE REJECTED.

2. PHYSICAL PROPERTIES AS FOLLOWS:

- CLAY - BETWEEN 7-27%
- SILT - BETWEEN 15-25%
- SAND - LESS THAN 52%
- ORGANIC MATTER SHALL BE 3%-10% OF TOTAL DRY WEIGHT.

3. IF REQUESTED, LANDSCAPE CONTRACTOR SHALL PROVIDE A CERTIFIED SOIL ANALYSIS CONDUCTED BY AN APPROVED SOIL TESTING LABORATORY VERIFYING THAT SANDY LOAM MEETS THE ABOVE REQUIREMENTS.

B. ORGANIC MATERIAL: COMPOST WITH A MIXTURE OF 80% VEGETATIVE MATTER AND 20% ANIMAL WASTE. INGREDIENTS SHOULD BE A MIX OF COARSE AND FINE TEXTURED MATERIAL.

C. PREMIXED BEDDING SOIL AS SUPPLIED BY VITAL EARTH RESOURCES, GLADEWATER, TEXAS; PROFESSIONAL BEDDING SOIL AS SUPPLIED BY LIVING EARTH TECHNOLOGY, DALLAS, TEXAS; OR ACID GRO MUNICIPAL MIX AS SUPPLIED BY SOIL BUILDING SYSTEMS, DALLAS, TEXAS OR APPROVED EQUAL.

D. SHARP SAND: SHARP SAND MUST BE FREE OF SEEDS, SOIL PARTICLES AND WEEDS.

E. MULCH: DOUBLE SHREDDED HARDWOOD MULCH, PARTIALLY DECOMPOSED, DARK BROWN.

F. ORGANIC FERTILIZER: FERTILIZED, SUSTANE, OR GREEN SEEN OR EQUAL AS RECOMMENDED FOR REQUIRED APPLICATIONS. FERTILIZER SHALL BE DELIVERED TO THE SITE IN ORIGINAL UNOPENED CONTAINERS, EACH BEARING THE MANUFACTURER'S GUARANTEED STATEMENT OF ANALYSIS.

G. COMMERCIAL FERTILIZER: 10-20-10 OR SIMILAR ANALYSIS. NITROGEN SOURCE TO BE A MINIMUM 20% SLOW RELEASE ORGANIC NITROGEN (SCU OR UF) WITH A MINIMUM 8% SULFUR AND 4% IRON, PLUS MICROINERTS.

H. FEAT: COMMERCIAL SPAGNUM PEAT MOSS OR PARTIALLY DECOMPOSED SHREDDED PINE BARK OR OTHER APPROVED ORGANIC MATERIAL.

2.3 MISCELLANEOUS MATERIALS

- STEEL EDGING - SHALL BE 3/16" X 4" X 16" DARK GREEN LANDSCAPE EDGING, DURABLE STEEL OR APPROVED EQUAL.
- TREE STAKING - TREE STAKING SOLUTIONS OR APPROVED SUBSTITUTE; REFER TO DETAILS.
- FILTER FABRIC - MIRAFI 1405 BY MIRAFI INC. OR APPROVED SUBSTITUTE, AVAILABLE AT LONE STAR PRODUCTS, INC. (469-923-0444)
- SAND - UNIFORMLY GRADED, WASHED, CLEAN, RAIN WASH SAND.
- GRAVEL - WASHED NATIVE GRAVEL GRADED 1" TO 1 1/2"
- DECOMPOSED GRANITE - BASE MATERIAL OF NATURAL MATERIAL MIX OF GRANITE AGGREGATE NOT TO EXCEED 1 1/8" IN DIAMETER COMPOSED OF VARIOUS STAGES OF DECOMPOSITION.
- ROCK - LOCALLY AVAILABLE NATIVE ROCK 1.5" IN DIAMETER.
- PRE-EMERGENT HERBICIDES: ANY GRANULAR, NON-STAINING PRE-EMERGENT HERBICIDE THAT IS LABELED FOR THE SPECIFIC ORNAMENTALS OR TURF ON WHICH IT WILL BE UTILIZED. PRE-EMERGENT

HERBICIDES SHALL BE APPLIED PER THE MANUFACTURERS LABELED RATES.

PART 3 - EXECUTION

3.1 PREPARATION

A. LANDSCAPE CONTRACTOR TO INSPECT ALL EXISTING CONDITIONS AND REPORT ANY DEFICIENCIES TO THE OWNER.

B. ALL PLANTING AREAS SHALL BE CONDITIONED AS FOLLOWS:

1. PREPARE NEW PLANTING BEDS BY SCRAPING AWAY EXISTING GRASS AND WEEDS AS NECESSARY. TILL EXISTING SOIL TO A DEPTH OF SIX (6") INCHES PRIOR TO PLACING COMPOST AND FERTILIZER. APPLY FERTILIZER AS PER MANUFACTURER'S RECOMMENDATIONS AND ADD SIX (6") INCHES OF COMPOST AND TILL INTO A DEPTH OF SIX (6") INCHES OF SPECIFIED MULCH (SETTLED THICKNESS).

2. BACKFILL FOR TREE PITS SHALL BE AS FOLLOWS: USE EXISTING TOP SOIL ON SITE (USE IMPORTED TOPSOIL AS NEEDED) FREE FROM LARGE CLUMPS, ROCKS, DEBRIS, CALICHE, SUBSOILS, ETC., PLACED IN NINE (9") INCH LAYERS AND WATERED IN THOROUGHLY.

C. GRASS AREAS:

1. BLOCKS OF SOD SHOULD BE LAID JOINT TO JOINT (STAGGERED JOINTS) AFTER FERTILIZING THE GROUND FIRST. ROLL GRASS AREAS TO ACHIEVE A SMOOTH, EVEN SURFACE. THE JOINTS BETWEEN THE BLOCKS OF SOD SHOULD BE FILLED WITH TOPSOIL WHERE THEY ARE GAPPED OPEN, THEN WATERED THOROUGHLY.

3.2 INSTALLATION

A. MAINTENANCE OF PLANT MATERIALS SHALL BEGIN IMMEDIATELY AFTER EACH PLANT IS DELIVERED TO THE SITE AND SHALL CONTINUE UNTIL CONSTRUCTION OF THE LANDSCAPE IS SATISFACTORY ACCOMPLISHED.

B. PLANT MATERIALS SHALL BE DELIVERED TO THE SITE ONLY AFTER THE BEDS ARE PREPARED AND AREAS ARE READY FOR PLANTING. ALL SHIPMENTS OF NURSERY MATERIALS SHALL BE THOROUGHLY PROTECTED FROM THE WINDS DURING TRANSIT. ALL PLANTS WHICH CANNOT BE PLANTED AT ONCE, AFTER DELIVERY TO THE SITE, SHALL BE WELL PROTECTED AGAINST THE POSSIBILITY OF DRYING BY WIND AND BALLS OF EARTH OR DAMAGE TO LEAVES.

C. POSITION THE TREES AND SHRUBS IN THEIR INTENDED LOCATION AS PER PLAN.

D. NOTIFY THE OWNER'S AUTHORIZED REPRESENTATIVE FOR INSPECTION AND APPROVAL OF ALL POSITIONING OF PLANT MATERIALS.

E. EXCAVATE PITS WITH VERTICAL SIDES AND HORIZONTAL BOTTOM. TREE PITS SHALL BE LARGE ENOUGH TO PERMIT HANDLING AND PLANTING WITHOUT INJURY TO BALLS OF EARTH OR ROOTS AND SHALL BE OF SUCH DEPTH THAT WHEN PLANTED AND SETTLED, THE CROWN OF THE PLANT SHALL BEAR THE SAME RELATIONSHIP TO THE FINISH GRADE AS IT DID TO SOIL SURFACE IN ORIGINAL PLACE OF GROWTH. THE SIDES OF THE HOLE SHOULD BE ROUGH AND JAGGED, NEVER SMOOTH OR GLAZED.

F. SHRUB AND TREE PITS SHALL BE NO LESS THAN TWENTY-FOUR (24") AND SIX (6") INCHES DEEPER THAN IT'S VERTICAL DIMENSION. REMOVE AND HAUL FROM SITE ALL ROCKS AND STONES OVER THREE-QUARTER (3/4") INCH IN DIAMETER. PLANTS SHOULD BE THOROUGHLY MOIST BEFORE REMOVING CONTAINERS.

G. PERCOLATION TEST: PERC. THE HOLE WITH WATER. IF THE WATER LEVEL DOES NOT PERCOLATE WITHIN 24 HOURS, THE TREE NEEDS TO MOVE TO ANOTHER LOCATION OR HAVE DRAINAGE ADDED. INSTALL A PVC STAND PIPE PER TREE IF THE PERCOLATION TEST FAILS.

H. BACKFILL ONLY WITH 5 PARTS EXISTING SOIL OR SANDY LOAM AND 1 PART BED PREPARATION. WHEN THE HOLE IS DUG IN SOLID ROCK, TOPSOIL FROM THE SAME AREA SHOULD NOT BE USED. CAREFULLY SETTLE BY WATERING TO PREVENT AIR POCKETS. REMOVE THE BURLAP FROM THE TOP 1/2 OF THE BALL, AS WELL AS ALL NYLON, PLASTIC STRIPING AND WIRE CONTAINERS WHICH WOULD BE ROOT BOUND. IF SO FLOW STANDARD NURSERY PRACTICE OF "ROOT SCORING".

I. DO NOT WRAP TREES.

K. REMOVE NURSERY TAGS AND STAKES FROM ALL PLANTS.

L. REMOVE BOTTOM OF PLANT BOXES PRIOR TO PLACING PLANTS. REMOVE SIDES AFTER PLACEMENT AND PARTIAL BACKFILLING.

M. REMOVE UPPER THIRD OF BURLAP FROM BALLED AND BURLAPPED TREES AFTER PLACEMENT.

N. PLACE PLANT UPRIGHT AND PLUMB IN CENTER OF HOLE. ORIENT PLANTS FOR BEST APPEARANCE.

O. MULCH THE TOP OF THE BALL. DO NOT PLANT GRASS ALL THE WAY TO THE TRUNK OF THE TREE. LEAVE THE AREA ABOVE THE TOP OF THE BALL AND MULCH WITH AT LEAST TWO (2") INCHES OF SPECIFIED MULCH.

P. ALL PLANT BEDS AND TREES TO BE MULCHED WITH A MINIMUM SETTLED THICKNESS OF TWO (2") INCHES OVER THE ENTIRE BED OR PIT.

Q. OBSTRUCTION BELOW GROUND: IN THE EVENT THAT ROCK, OR UNDERGROUND CONSTRUCTION WORK OR OBSTRUCTIONS ARE ENCOUNTERED IN ANY PLANT PIT EXCAVATION WORK TO BE DONE UNDER THIS SECTION, ALTERNATE LOCATIONS MAY BE SELECTED BY THE OWNER. WHERE LOCATIONS CANNOT BE CHANGED, THE OBSTRUCTIONS SHALL BE REMOVED TO A DEPTH OF NOT LESS THAN THREE (3") FEET BELOW GRADE AND NO LESS THAN SIX (6") INCHES BELOW THE BOTTOM OF BALL WHEN PLANTS ARE PROPERLY SET AT THE REQUIRED GRADE. THE WORK OF THIS SECTION SHALL INCLUDE THE REMOVAL FROM THE SITE OF SUCH ROCK OR UNDERGROUND OBSTRUCTIONS ENCOUNTERED AT THE COST OF THE LANDSCAPE CONTRACTOR.

R. TREES AND LARGE SHRUBS SHALL BE STAKED AS SITE CONDITIONS REQUIRE. POSITION STAKES TO SECURE TREES AGAINST SEASONAL PREVAILING WINDS.

S. PRUNING AND MULCHING: PRUNING SHALL BE DIRECTED BY THE LANDSCAPE ARCHITECT AND SHOWN ON THE PLAN. ACCORDANCE WITH STANDARD HORTICULTURAL PRACTICE FOLLOWING FINE PRUNING, CLASS "B" PRUNING STANDARDS PROVIDED BY THE NATIONAL ARBORICULTURAL SOCIETY SHALL BE USED.

1. DEAD WOOD, SUCKERS, BROKEN AND BADLY BRUISED BRANCHES SHALL BE REMOVED. GENERAL TRIPPING OF THE BRANCHES IS NOT PERMITTED. DO NOT CUT TERMINAL BRANCHES.

2. PRUNING SHALL BE DONE WITH CLEAN, SHARP TOOLS.

3. IMMEDIATELY AFTER PLANTING OPERATIONS ARE COMPLETED, ALL TREE PITS SHALL BE COVERED WITH A LAYER OF ORGANIC MATERIAL TWO (2") INCHES IN DEPTH. THIS LIMIT OF THE ORGANIC MATERIAL FOR TREES SHALL BE THE DIAMETER OF THE PLANT PIT.

4. STAKES ARE TO BE INSTALLED ON THE PLANTING BED SIDE OF THE CURBING, AS OPPOSED TO THE GRASS SIDE.

5. DO NOT INSTALL STEEL EDGING ALONG SIDEWALKS OR CURBS.

6. CUT STEEL EDGING AT 45 DEGREE ANGLE WHERE EDGING MEETS SIDEWALKS OR CURBS.

7. STAKES ARE TO BE INSTALLED ON THE PLANTING BED SIDE OF THE CURBING, AS OPPOSED TO THE GRASS SIDE.

8. CUT STEEL EDGING AT 45 DEGREE ANGLE WHERE EDGING MEETS SIDEWALKS OR CURBS.

3.3 CLEANUP AND ACCEPTANCE

A. CLEANUP: DURING THE WORK, THE PREMISES SHALL BE KEPT NEAT AND ORDERLY AT ALL TIMES. STORAGE AREAS FOR ALL MATERIALS SHALL BE SO ORGANIZED SO THAT THEY, TOO, ARE NEAT AND ORDERLY. ALL TRASH AND DEBRIS SHALL BE REMOVED FROM THE SITE AS WORK PROGRESSES. KEEP PAVED AREAS CLEAN BY SWEEPING OR HOING THEM AT END OF EACH WORK DAY.

B. REPAIR RUTS, HOLES AND SCARS IN GROUND SURFACES.

C. ENSURE THAT WORK IS COMPLETE AND PLANT MATERIALS ARE IN VIGOROUS AND HEALTHY GROWING CONDITION.

D. UPON COMPLETION OF THE WORK, THE LANDSCAPE CONTRACTOR SHALL PROVIDE THE SITE CLEAN, FREE OF DEBRIS AND SUFFICIENT FOR USE AS INTENDED. THE LANDSCAPE CONTRACTOR SHALL THEN REQUEST AN INSPECTION BY THE OWNER TO DETERMINE FINAL ACCEPTANCE.

E. WHEN THE INSPECTED PLANTING WORK DOES NOT COMPLY WITH THE CONTRACT DOCUMENTS, THE LANDSCAPE CONTRACTOR SHALL REPLACE AND/OR REPAIR THE REJECTED WORK TO THE OWNERS SATISFACTION WITHIN 24 HOURS.

F. THE LANDSCAPE MAINTENANCE PERIOD WILL NOT COMMENCE UNTIL THE LANDSCAPE WORK HAS BEEN REINSPECTED BY THE OWNER AND FOUND TO BE ACCEPTABLE. AT THAT TIME, A WRITTEN NOTICE OF FINAL ACCEPTANCE WILL BE ISSUED BY THE OWNER, AND THE MAINTENANCE AND GUARANTEE PERIODS WILL COMMENCE.

END OF SECTION

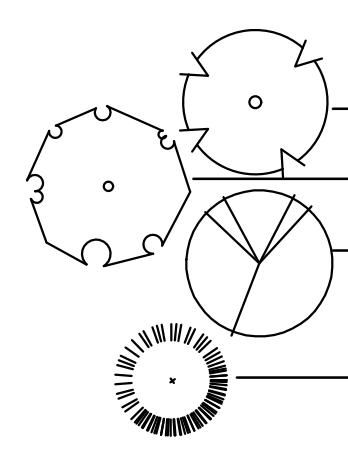

QTY	LABEL	COMMON NAME	SCIENTIFIC NAME	SIZE	NOTES	MATURE SIZE	YEARS TO MATURITY
DECIDUOUS TREES							
3	AE	Acolade Elm	<i>Ulmus 'Acolade'</i>	3" cal.	12' ht., 4' spread	60' ht x 40' w	10-15 years
3	RL	Redmond Linden	<i>Tilia americana 'Redmond'</i>	3" cal.	12' ht., 4' spread	60' ht x 40' w	20-30 years
8	RO	Northern Red Oak	<i>Quercus rubra</i>	3" cal.	12' ht., 5' spread	60' ht x 40' w	30-35 years
14	TOTAL DECIDUOUS TREES						
EVERGREEN TREES							
5	LP	Lacebark Pine	<i>Pinus bungeana</</i>				

TOWN OF PARKER STANDARD DETAILS

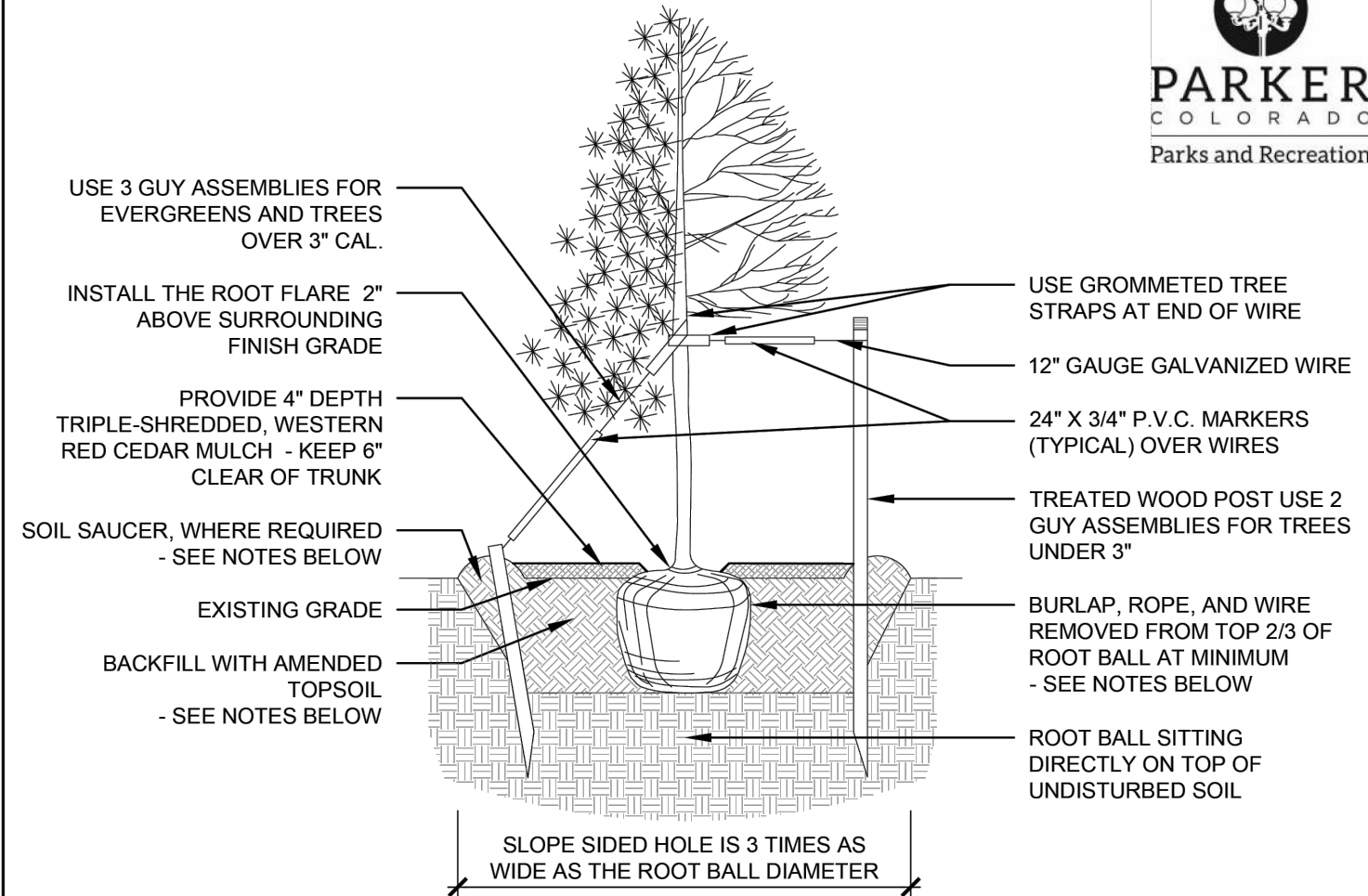

- NOTES:
- EXCAVATE PLANTING HOLES WITH SLOPING SIDES, MAKE EXCAVATIONS AT LEAST THREE TIMES AS WIDE AS THE ROOT BALL DIAMETER AND NO DEEPER THAN THE DISTANCE FROM THE TOP OF THE ROOT BALL TO ALLOW FOR SETTLING. DO NOT DISTURB SOIL AT BOTTOM OF PLANTING HOLES, BUT DO SCORE THE SIDES OF THE PLANTING HOLE. THE PLANTING AREA SHALL BE LOOSENED AND AERATED AT LEAST THREE TIMES THE DIAMETER OF THE ROOT BALL.
 - BACKFILL SHALL CONSIST OF APPROVED ON-SITE TOPSOIL BLENDED W/ COMPOST AMENDMENT. IF ON-SITE TOPSOILS ARE NOT APPROVED FOR USE, BACKFILL W/ IMPORTED TOPSOIL BLENDED WITH COMPOST AMENDMENT. REFER TO SPECIFICATION SECTION 329113 FOR ADDITIONAL INFORMATION.
 - TREES SHALL BE PLANTED WITH THE ROOT COLLAR/FLARE VISIBLE ABOVE GRADE AND TWO OR MORE STRUCTURAL ROOTS LOCATED WITHIN THE TOP 1" TO 2" OF THE ROOT BALL/FINISHED GRADE MEASURED 3" TO 4" FROM TRUNK. THIS INCLUDES TREES THAT ARE SET ON SLOPES (SEE SLOPE PLANTING DETAIL). TREES THAT DO NOT HAVE A VISIBLE ROOT COLLAR SHALL BE REJECTED. DO NOT COVER THE ROOT BALL WITH SOIL.
 - WHEN ROOT BALL WILL REMAIN INTACT, CUT OFF BOTTOM 1/4 OF WIRE BASKET BEFORE PLACING TREE IN HOLE. CUT OFF REMAINDER OF BASKET AFTER TREE IS SET IN HOLE. REMOVE BASKET COMPLETELY. AT A MINIMUM, THE TOP 2/3 OF THE BURLAP AND BASKET SHALL BE REMOVED FROM THE ROOT BALL ON ALL TREES. REMOVE ALL NYLON TIES, TWINE, ROPE AND BURLAP. REMOVE UNNECESSARY PACKING MATERIAL.
 - FORM SOIL INTO A 6" TALL WATERING RING (SAUCER) AROUND PLANTING AREA. THIS IS NOT NECESSARY IN IRRIGATED TURF AREAS. APPLY 4" DEPTH OF SPECIFIED MULCH OVER PLANTING AREA AND INSIDE SAUCERS, AWAY FROM TRUNK.
 - STAKING AND GUYING OF TREES IS OPTIONAL IN MOST PLANTING SITUATIONS. IN AREAS OF EXTREME WINDS, OR ON STEEP SLOPES, STAKING MAY BE REQUIRED TO STABILIZE TREES. STAKING AND GUYING MUST BE REMOVED WITHIN 1 YEAR OF PLANTING DATE.
 - TREE WRAP IS NOT TO BE USED ON ANY NEW PLANTINGS, EXCEPT IN LATE FALL PLANTING SITUATIONS, AND ONLY AFTER CONSULTATION WITH THE TOWN ARBORIST.
 - RESETTING OF IMPROPERLY PLANTED TREES WILL ONLY BE ALLOWED IF IT IS DETERMINED THAT DOING SO WILL IN NO WAY COMPROMISE THE ROOT BALL, AND SHALL ONLY BE DONE WITH APPROVAL OF THE TOWN ARBORIST.

TREE PLANTING
1/4" = 1'-0"

DATE: MAY 2023 | DETAIL SD-3

TOWN OF PARKER STANDARD DETAILS

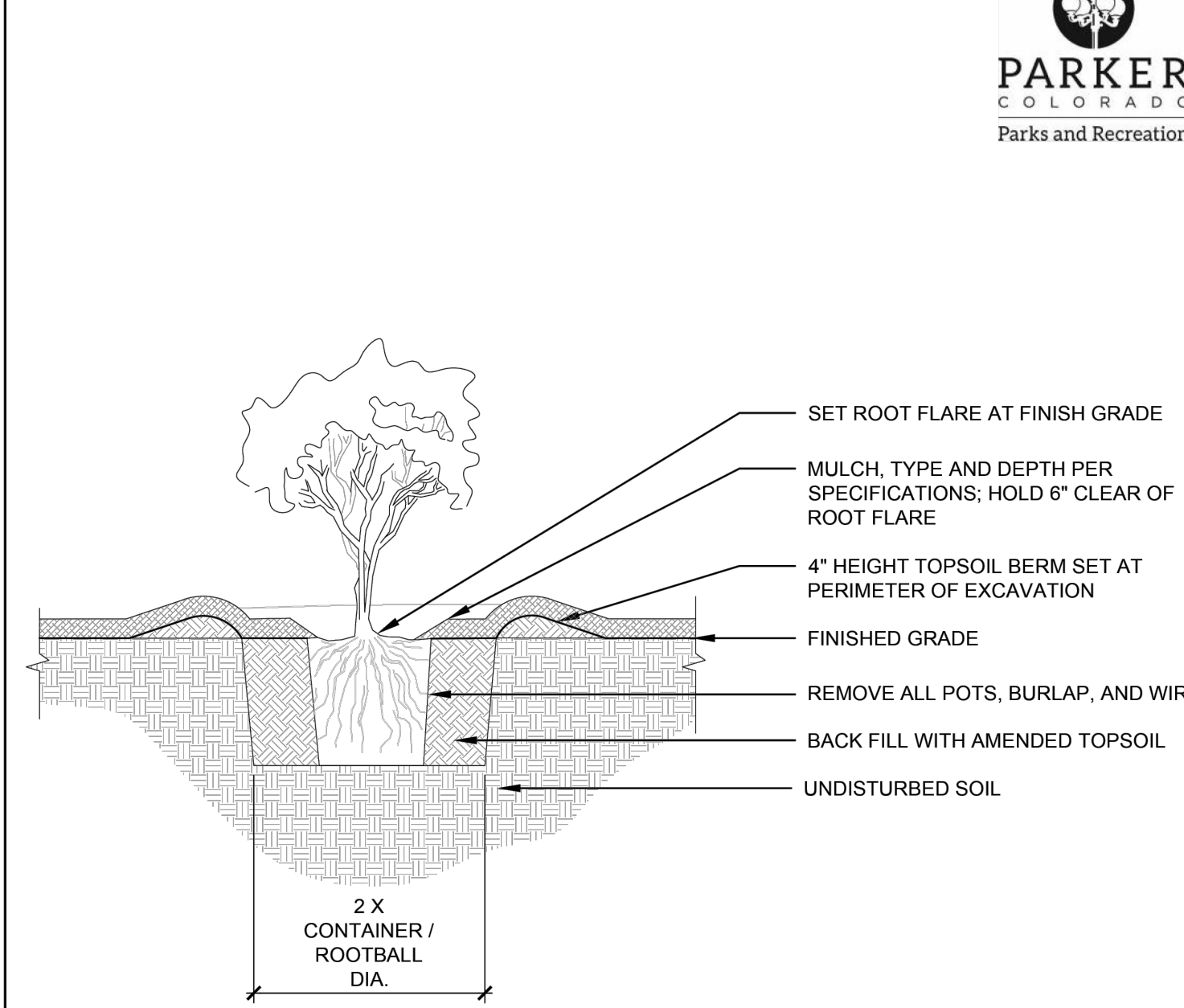

- NOTES:
- PRUNE ALL DAMAGED, DISEASED OR WEAK LIMBS.
 - CLEANLY PRUNE ALL DAMAGED ROOT ENDS.
 - DO NOT ALLOW ROOTS TO DRY OUT DURING INSTALLATION PROCESS.
 - DEEP WATER AFTER PLANTING.

SHRUB PLANTING
1/2" = 1'-0"

DATE: MAY 2023 | DETAIL SD-5

TOWN OF PARKER STANDARD DETAILS

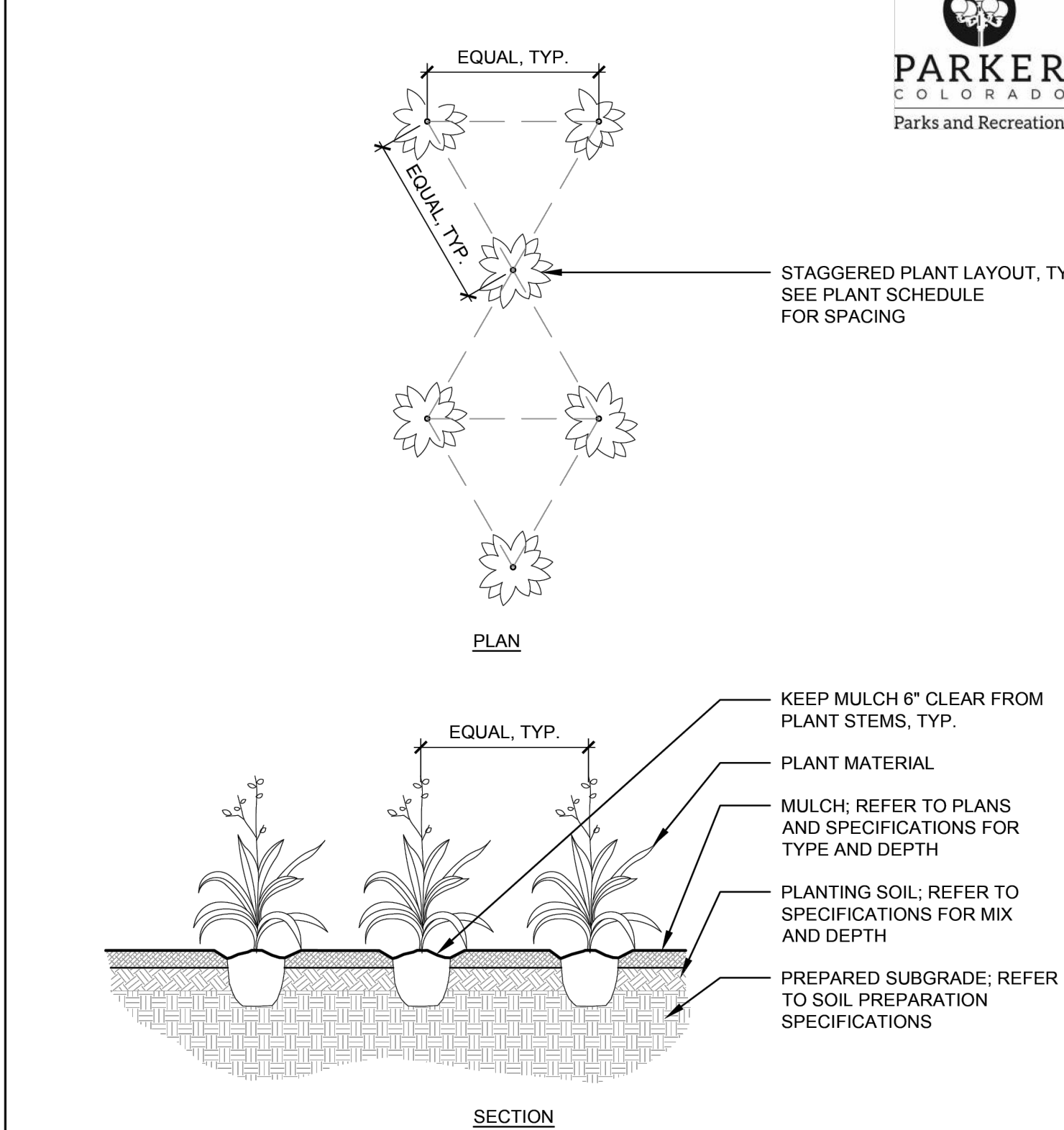

- NOTES:
- WHEN BACKFILLING AROUND PLANTS, DO NOT ALLOW AIR POCKETS TO FORM.
 - AFTER PLANTING, WATER THOROUGHLY.

PERENNIAL PLANTING
1/4" = 1'-0"

DATE: MAY 2023 | DETAIL SD-6

TOWN OF PARKER STANDARD DETAILS

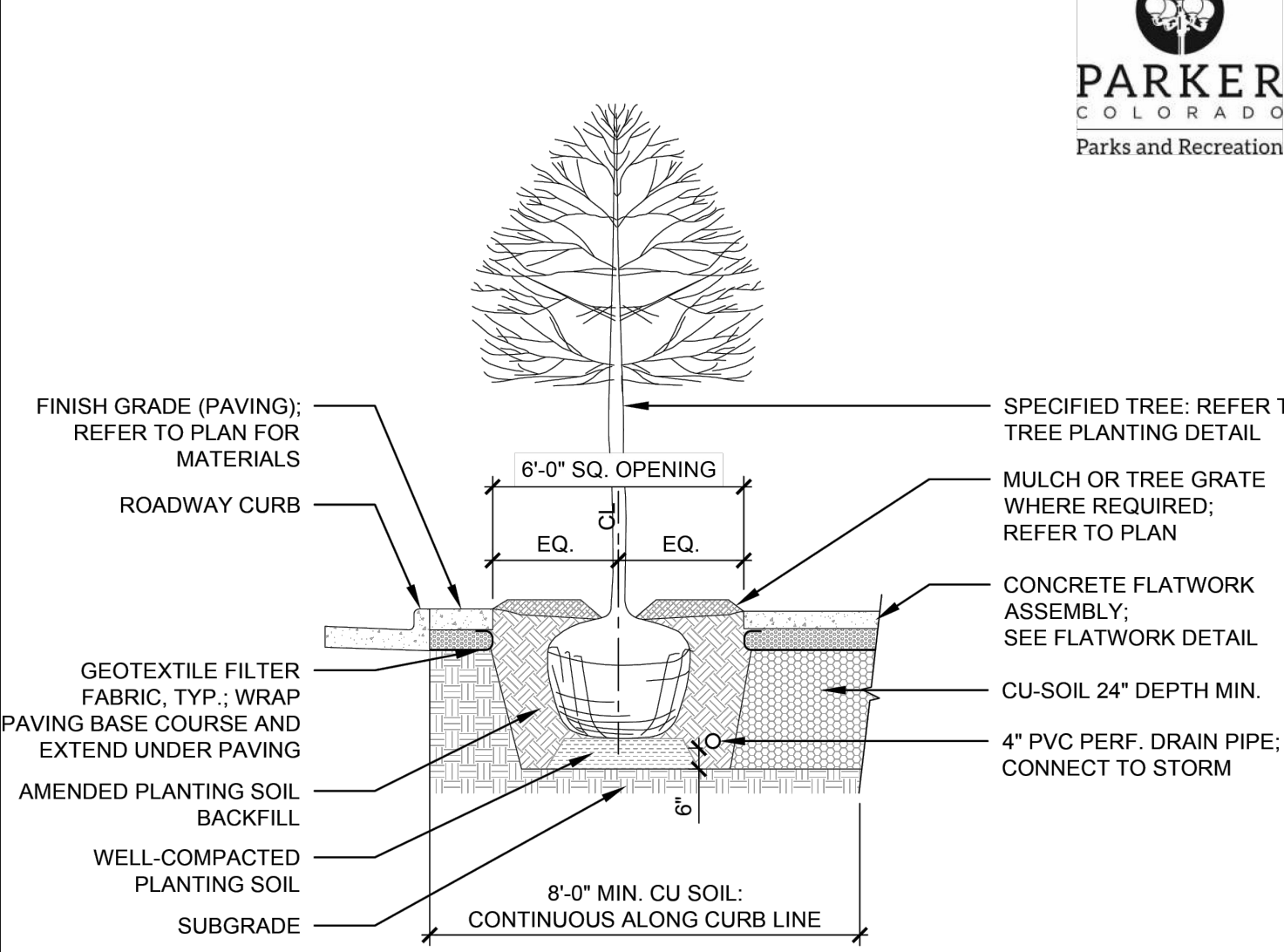
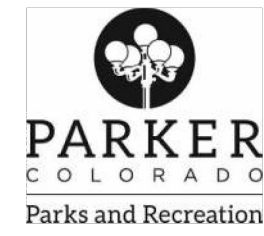

- NOTES:
- TREES SHALL BE PLANTED WITH THE ROOT COLLAR/FLARE VISIBLE ABOVE GRADE AND TWO OR MORE STRUCTURAL ROOTS LOCATED WITHIN THE TOP 1" TO 2" OF THE ROOT BALL/FINISHED GRADE MEASURED 3" TO 4" FROM TRUNK.
 - WHEN ROOT BALL WILL REMAIN INTACT, CUT OFF BOTTOM 1/4 OF WIRE BASKET BEFORE PLACING TREE IN HOLE. CUT OFF REMAINDER OF BASKET AFTER TREE IS SET IN HOLE. REMOVE BASKET COMPLETELY. AT A MINIMUM, THE TOP 2/3 OF THE BURLAP AND BASKET SHALL BE REMOVED FROM THE ROOT BALL ON ALL TREES. REMOVE ALL NYLON TIES, TWINE, ROPE AND BURLAP. REMOVE UNNECESSARY PACKING MATERIAL.
 - TREE WRAP IS NOT TO BE USED ON ANY NEW PLANTINGS, EXCEPT IN LATE FALL PLANTING SITUATIONS, AND ONLY AFTER CONSULTATION WITH THE TOWN ARBORIST.
 - RESETTING OF IMPROPERLY PLANTED TREES WILL ONLY BE ALLOWED IF IT IS DETERMINED THAT DOING SO WILL IN NO WAY COMPROMISE THE ROOT BALL, AND SHALL ONLY BE DONE WITH APPROVAL OF THE TOWN ARBORIST.

CU SOIL TREE PIT
1/4" = 1'-0"

DATE: MAY 2023 | DETAIL SD-2

TOWN OF PARKER STANDARD DETAILS

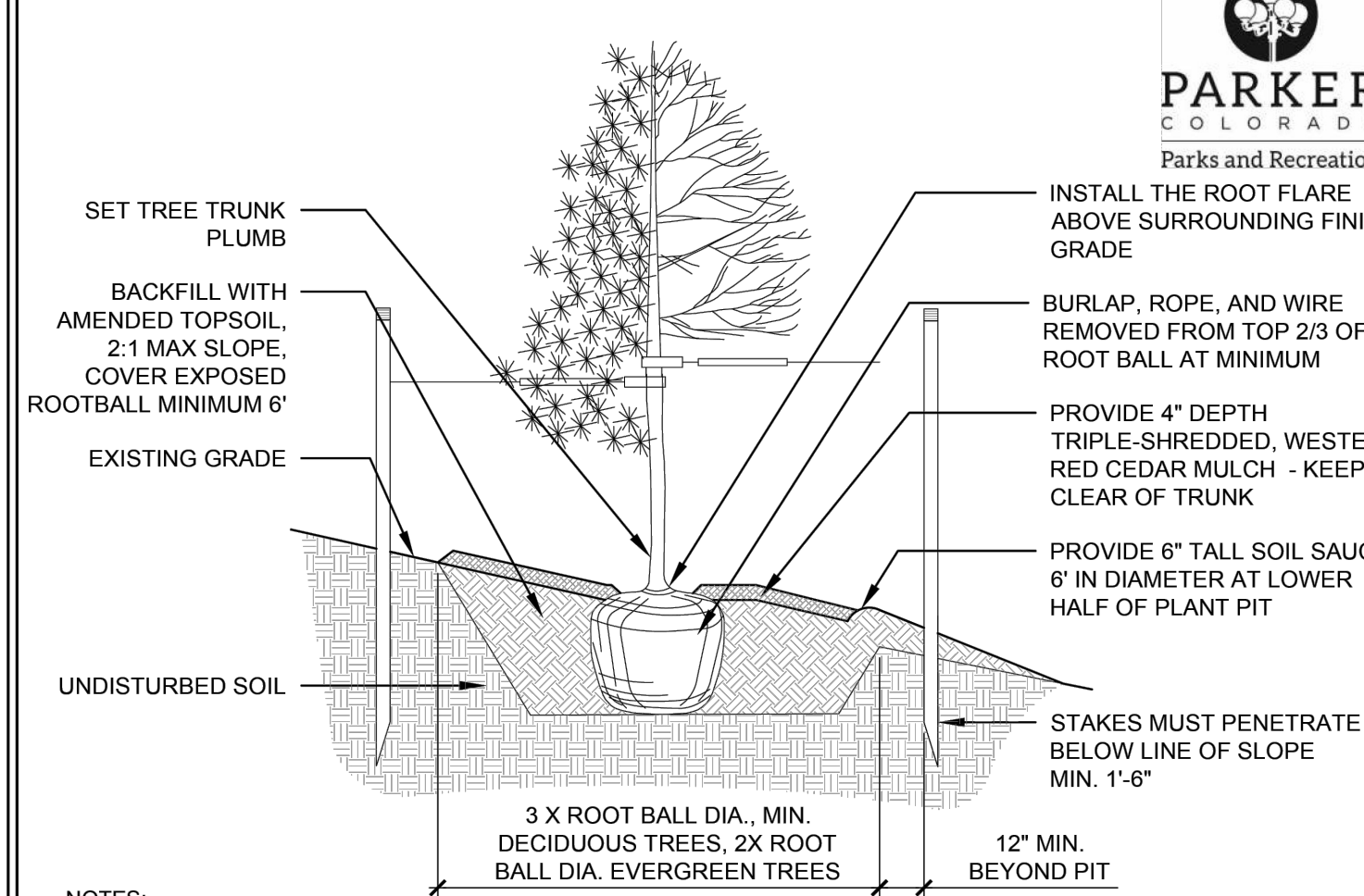

- NOTES:
- THIS INSTALLATION SHALL APPLY TO ALL TREE TYPES AND SIZES PLANTED ON SLOPES 4:1 OF GREATER.
 - EXCAVATE PLANTING HOLES WITH SLOPING SIDES, MAKE EXCAVATIONS AT LEAST THREE TIMES AS WIDE AS THE ROOT BALL DIAMETER AND NO DEEPER THAN THE DISTANCE FROM THE TOP OF THE ROOT BALL TO ALLOW FOR SETTLING. DO NOT DISTURB SOIL AT BOTTOM OF PLANTING HOLES, BUT DO SCORE THE SIDES OF THE PLANTING HOLE. THE PLANTING AREA SHALL BE LOOSENED AND AERATED AT LEAST THREE TIMES THE DIAMETER OF THE ROOT BALL.
 - BACKFILL SHALL CONSIST OF APPROVED ON-SITE TOPSOIL BLENDED W/ COMPOST AMENDMENT. OF ON-SITE TOPSOILS ARE NOT APPROVED FOR USE, BACKFILL W/ IMPORTED TOPSOIL BLENDED WITH COMPOST AMENDMENT. REFER TO SPECIFICATION SECTION 329113 FOR ADDITIONAL INFORMATION.
 - TREES SHALL BE PLANTED WITH THE ROOT COLLAR/FLARE VISIBLE ABOVE GRADE AND TWO OR MORE STRUCTURAL ROOTS LOCATED WITHIN THE TOP 1" TO 2" OF THE ROOT BALL/FINISHED GRADE MEASURED 3" TO 4" FROM TRUNK. THIS INCLUDES TREES THAT ARE SET ON SLOPES (SEE SLOPE PLANTING DETAIL). TREES THAT DO NOT HAVE A VISIBLE ROOT COLLAR SHALL BE REJECTED. DO NOT COVER THE ROOT BALL WITH SOIL.
 - WHEN ROOT BALL WILL REMAIN INTACT, CUT OFF BOTTOM 1/4 OF WIRE BASKET BEFORE PLACING TREE IN HOLE. CUT OFF REMAINDER OF BASKET AFTER TREE IS SET IN HOLE. REMOVE BASKET COMPLETELY. AT A MINIMUM, THE TOP 2/3 OF THE BURLAP AND BASKET SHALL BE REMOVED FROM THE ROOT BALL ON ALL TREES. REMOVE ALL NYLON TIES, TWINE, ROPE AND BURLAP. REMOVE UNNECESSARY PACKING MATERIAL.
 - FORM SOIL INTO A 6" TALL WATERING RING (SAUCER) AROUND PLANTING AREA. THIS IS NOT NECESSARY IN IRRIGATED TURF AREAS. APPLY 4" DEPTH OF SPECIFIED MULCH OVER PLANTING AREA AND INSIDE SAUCERS, AWAY FROM TRUNK.
 - STAKING AND GUYING OF TREES IS OPTIONAL IN MOST PLANTING SITUATIONS. IN AREAS OF EXTREME WINDS, OR ON STEEP SLOPES, STAKING MAY BE REQUIRED TO STABILIZE TREES. STAKING AND GUYING MUST BE REMOVED WITHIN 1 YEAR OF PLANTING DATE.
 - TREE WRAP IS NOT TO BE USED ON ANY NEW PLANTINGS, EXCEPT IN LATE FALL PLANTING SITUATIONS, AND ONLY AFTER CONSULTATION WITH THE TOWN ARBORIST.
 - RESETTING OF IMPROPERLY PLANTED TREES WILL ONLY BE ALLOWED IF IT IS DETERMINED THAT DOING SO WILL IN NO WAY COMPROMISE THE ROOT BALL, AND SHALL ONLY BE DONE WITH APPROVAL OF THE TOWN ARBORIST.

TREE PLANTING ON SLOPE
1/4" = 1'-0"

DATE: MAY 2023 | DETAIL SD-4

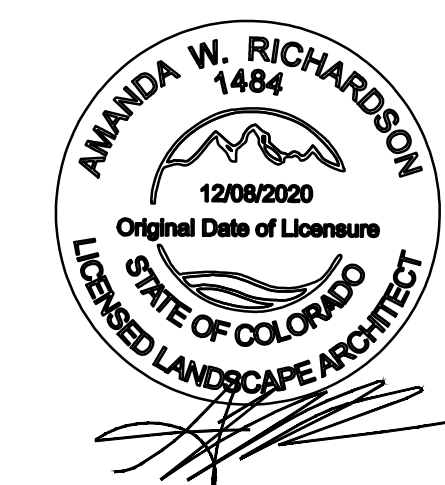

CALL UTILITY NOTIFICATION CENTER OF COLORADO 1-800-922-1987
CALL 2-BUSINESS DAYS IN ADVANCE BEFORE YOU DIG, GRADE, OR EXCAVATE FOR THE MARKING OF UNDERGROUND MEMBER UTILITIES.



Know what's Below. Call before you dig. THE LOCATIONS OF EXISTING UNDERGROUND UTILITIES ARE SHOWN IN AN APPROXIMATE MANNER AND HAVE NOT BEEN INDEPENDENTLY VERIFIED BY THE OWNER OR ITS REPRESENTATIVE. THE CONTRACTOR SHALL DETERMINE THE EXACT LOCATION OF ALL EXISTING UTILITIES BEFORE COMMENCING WORK AND ASSUME FULL RESPONSIBILITY FOR ANY AND ALL DAMAGES WHICH MIGHT BE OCCURRED BY THE CONTRACTOR'S FAILURE TO EXACTLY LOCATE AND PRESERVE ANY AND ALL UNDERGROUND UTILITIES.

NOTICE: CONSTRUCTION SITE SAFETY IS THE SOLE RESPONSIBILITY OF THE CONTRACTOR. NEITHER THE OWNER NOR THE ENGINEER SHALL BE HELD RESPONSIBLE FOR ANY PERSONS ENGAGED IN THE WORK OF ANY NEARBY STRUCTURES, OR OF ANY OTHER PERSONS.

COPYRIGHT © 2023 ATWELL LLC. NO REPRODUCTION SHALL BE MADE WITHOUT THE PRIOR WRITTEN CONSENT OF ATWELL LLC.

24 HOUR EMERGENCY CONTACT

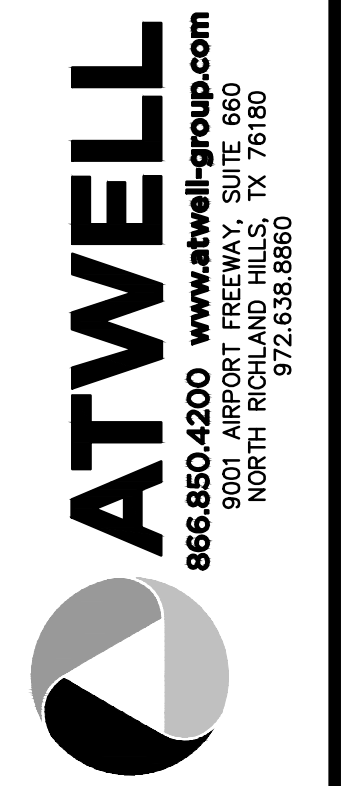

LOT 4A, PARKER POINTE SUBD. FILING NO. 1, AMEND. NO. 1
S. PARKER RD & STROH RD
PARKER
DOUGLAS COUNTY, COLORADO

BLACK ROCK COFFEE BAR
13135 DECLAN DRIVE
LANDSCAPE DETAILS

DATE: 2025-8-21

REVISIONS

DRAWN BY: K. SARWAR
CHECKED BY: N. SALAZAR
PROJECT MANAGER: N. SALAZAR
JOB #: 24003198
FILE CODE: ##
SHEET NO. L1.03

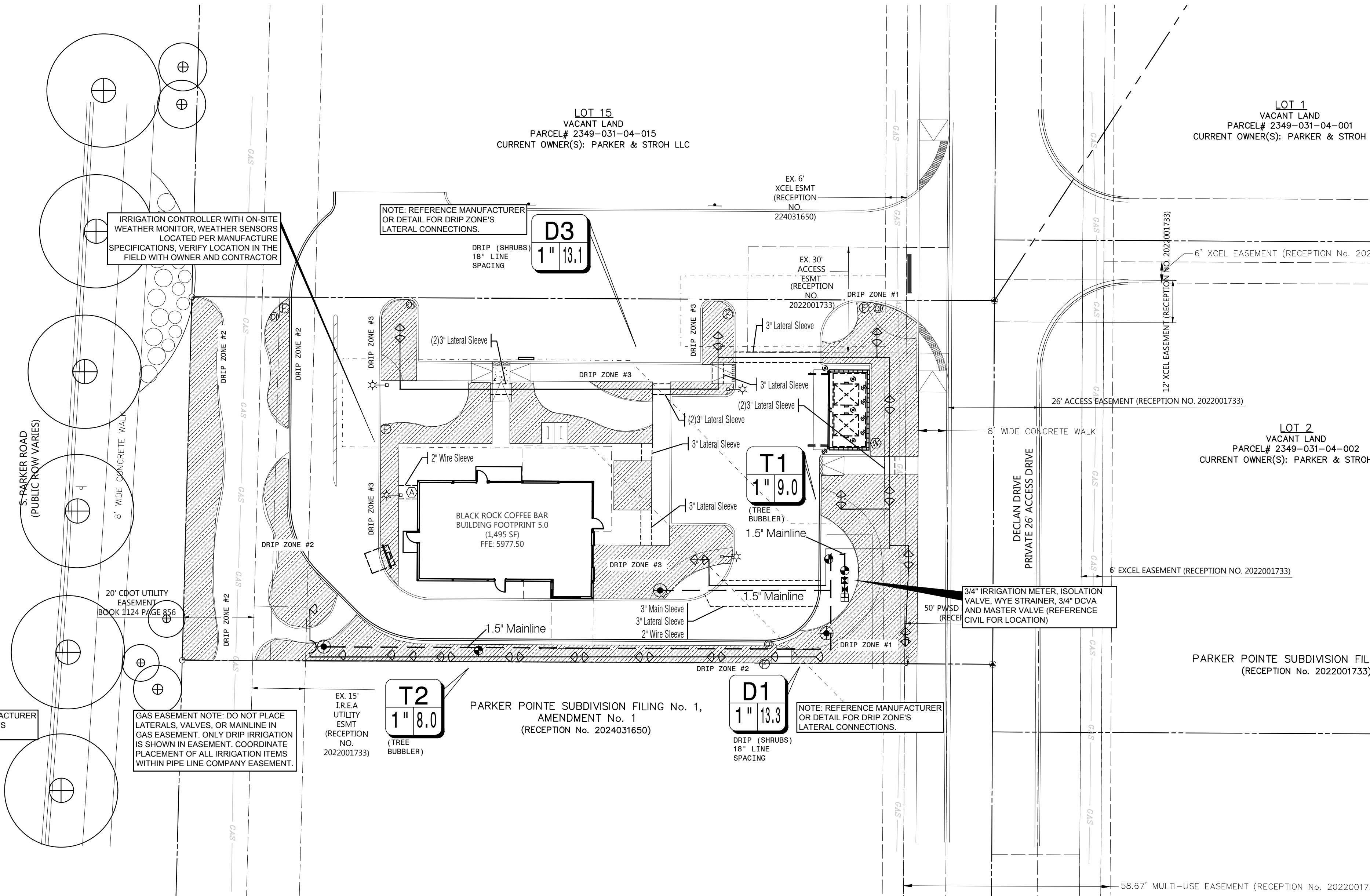

SLEEVING NOTES

1. PIPING AND CONTROL WIRES SHALL BE INSTALLED IN SEPARATE SLEEVES UNDER PAVING. REFERENCE DRAWINGS FOR SLEEVE SIZE AND LOCATION.
2. SLEEVES SHALL BE FURNISHED AND INSTALLED BY GENERAL CONTRACTOR.
3. INSTALLATION OF SLEEVES SHALL BE TWENTY (20) FEET BELOW TOP OF PAVEMENT OR FINISHED GRADE.
4. SLEEVES SHALL EXTEND ONE (1) FOOT BEYOND EDGE OF ALL PAVEMENT AND STAKED FOR LOCATION.
5. ALL SLEEVES SHALL BE SCHEDULE 40 PVC PIPE, CAPPED ON BOTH ENDS AND SIZED AT LEAST TWO TIMES LARGER THAN THE DIAMETER OF THE PIPE INSIDE THE SLEEVE.
6. SLEEVE LOCATIONS SHALL BE MARKED ON THE CURB WITH A SAWCUT OF TWO PARALLEL LINES THAT ARE TWO (2) INCHES LONG AND ONE (1) INCH APART.
7. CONTRACTOR IS RESPONSIBLE FOR THE INSTALLATION OF SLEEVES AND SHALL ALSO BE RESPONSIBLE FOR LOCATING ANY SLEEVE THAT CANNOT BE FOUND DURING THE INSTALLATION OF THE SYSTEM.
8. CONTRACTOR SHALL FURNISH OWNER AND IRRIGATION CONTRACTOR WITH AN AS-BUILT DRAWING SHOWING ALL SLEEVE LOCATIONS.

IRRIGATION GENERAL NOTES

1. THE IRRIGATION CONTRACTOR SHALL COORDINATE INSTALLATION OF THE IRRIGATION SYSTEM WITH THE LANDSCAPE CONTRACTOR SO THAT ALL PLANT MATERIAL WILL BE WATERED IN ACCORDANCE WITH THE INTENT OF THE PLANS AND SPECIFICATIONS.
2. THE CONTRACTOR SHALL BE RESPONSIBLE TO NOTIFY THE IRRIGATION DESIGNER OF SITE CONDITIONS OR ASSUME FULL RESPONSIBILITY FOR ANY AND ALL ON SITE REVISIONS NECESSARY.
3. CONTRACTOR TO VERIFY DESIGN AND ITS INTENT TO PROVIDE FULL COVERAGE TO ALL NEW PLANTING MATERIAL.
4. NOTIFY IRRIGATION DESIGNER OF ANY LAYOUT DISCREPANCIES PRIOR TO BIDDING.
5. LOCATE ALL UTILITIES AND SITE LIGHTING CONDUITS BEFORE IRRIGATION INSTALLATION BEGINS.
6. IRRIGATION CONTRACTOR TO PROCURE ALL PERMITS, LICENSES AND GIVE ALL NECESSARY NOTICES THROUGHOUT THE DURATION OF THE PROJECT.
7. THE CONTRACTOR SHALL BE A REGISTERED LICENSED IRRIGATOR IN GOOD STANDING WITH STATE BOARDS AND REGULATORS.
8. THE CONTRACTOR SHALL BE RESPONSIBLE FOR ANY AND ALL PLANT MATERIAL UPON ACCEPTANCE AND THROUGH THE WARRANTY PERIOD FOR DAMAGE DUE TO IRRIGATION SYSTEM FAILURE.
9. ALL ASPECTS OF THE IRRIGATION INSTALLATION SHALL CONFORM WITH THE PROPER GOVERNING AUTHORITIES, CODES AND ORDINANCES.
10. SLEEVES SHALL BE FURNISHED AND INSTALLED BY GENERAL CONTRACTOR. SLEEVE MATERIAL SHALL BE SCHEDULE 40, SIZE AS INDICATED ON PLAN. REFER TO SLEEVING NOTES.
11. ALL MAIN LINE AND LATERAL LINE PIPING IN PLANTING AND LAWN AREAS SHALL HAVE A MINIMUM OF 12 INCHES OF COVER. ALL PIPING UNDER PAVING SHALL HAVE A MINIMUM OF 18 INCHES OF COVER. CONTRACTOR TO VERIFY LOCAL FREEZE DEPTHS AND ADJUST DEPTH OF COVER ACCORDINGLY.
12. ZONE VALVES SHALL NOT BE LOCATED WITHIN THREE (3) FEET OF ANY DRIVEWAY, TRAFFIC AISLE, ISLAND ETC. WHERE THEY WILL BE DAMAGED BY VEHICLES DRIVING OVER CURBS.
13. ALL NOZZLES IN PARKING LOT ISLANDS AND PLANTING BEDS SHALL BE LOW ANGLE NOZZLES TO MINIMIZE OVER SPRAY ON PAVEMENT SURFACES.
14. AUTOMATIC CONTROLLER SHALL BE INSTALLED AT LOCATION SHOWN. POWER (120V) SHALL BE LOCATED IN A JUNCTION BOX WITHIN FIVE (5) FEET OF CONTROLLER. LOCATION BY OTHER TRADES. RAIN AND FREEZE SENSORS SHALL BE INSTALLED WITH EACH CONTROLLER.
15. ELECTRICAL SPLICES SHOULD BE LOCATED AT EACH VALVE AND CONTROLLER ONLY.
16. PROVIDE A 3/4\"/>

IRRIGATION PROJECT NOTES

1. THE LOCATION OF MAINLINE AND VALVES ON THIS PLAN MAY BE SHOWN IN PAVED AREAS FOR DESIGN CLARITY ONLY. IRRIGATION ELEMENTS HAVE BEEN SHOWN ON THIS PLAN AS ACCURATELY AS POSSIBLE WITHOUT THE FORFEIT OF DESIGN CLARITY AND INTENT. ALL PIPES AND VALVES SHALL BE INSTALLED WITHIN PERVIOUS AREAS. ALL PIPE AND WIRES THAT CROSS UNDER PAVING SHALL BE INSTALLED IN SEPARATE SLEEVES AS SPECIFIED.
2. ALL SPRINKLER EQUIPMENT NUMBERS REFERENCE THE HUNTER EQUIPMENT CATALOG UNLESS OTHERWISE INDICATED.
3. TEN DAYS PRIOR TO START OF CONSTRUCTION, IRRIGATION CONTRACTOR SHALL VERIFY STATIC WATER PRESSURE. THE IRRIGATION SYSTEM FOR THIS SITE IS DESIGNED TO OPERATE WITH A PRESSURE OF SIXTY (60 PSI) POUNDS PER SQUARE INCH. SHOULD THE DESIGN PRESSURE FOR THE SYSTEM BE HIGHER THAN THE EXISTING PRESSURE, THE IRRIGATION CONTRACTOR SHALL NOTIFY THE IRRIGATION DESIGNER IMMEDIATELY.
4. IRRIGATION CONTRACTOR SHALL COORDINATE THE LOCATION OF THE CONTROLLER AND SENSORS WITH THE GENERAL CONTRACTOR AND OWNER. SERVICE LINE AND METER SHALL BE SIZED AS NOTED ON THIS PLAN.
5. WATER SERVICE TAP, METER AND LEAD FOR THE IRRIGATION SYSTEM SHALL BE PROVIDED AND INSTALLED BY THE GENERAL CONTRACTOR. SERVICE LINE AND METER SHALL BE SIZED AS NOTED ON THIS PLAN.
6. TYPE AND INSTALLATION OF THE WATER METER AND BACK FLOW PREVENTION DEVICE SHALL BE DETERMINED BY THE GOVERNING AUTHORITY. AN ISOLATION VALVE SHALL BE PROVIDED BETWEEN THE WATER METER AND BACK FLOW DEVICE.
7. ALL CALCULATIONS FOR THIS IRRIGATION SYSTEM ARE BASED ON PRODUCTS AND EQUIPMENT INFORMATION PROVIDED BY HUNTER. INSTALLATION OF THESE PRODUCTS SHALL NOT EXCEED MANUFACTURER'S RECOMMENDATIONS.
8. REFERENCE HUNTER GUIDELINES AND SPECIFICATIONS PRIOR TO INSTALLATION. CONFIRM REQUIREMENTS FOR CONTROLLER, WATERPROOF CONNECTIONS, GROUNDING, SURGE PROTECTORS, DECODERS, VALVES AND WIRING PRIOR TO INSTALLATION. HUNTER TECHNICAL SERVICES (760) 591-7383. WWW.HUNTERINDUSTRIES.COM
9. IRRIGATION REMOTE CONTROL VALVES SHALL BE 1\"/>

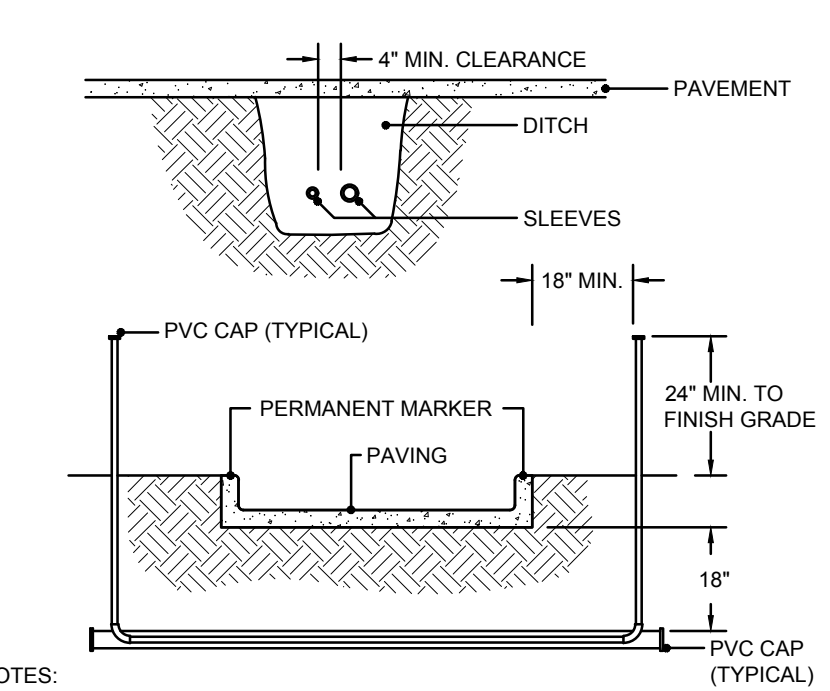

- 1 IRRIGATION PVC SLEEVES**
N.T.S.
1. ALL PVC IRRIGATION SLEEVES TO BE SCHEDULE 40 PIPE.
 2. ALL JOINTS TO BE SOLVENT WELDED AND WATER TIGHT.
 3. WHERE THERE IS MORE THAN ONE SLEEVE, EXTEND THE SMALLER SLEEVE TO 24-INCHES MINIMUM ABOVE FINISH GRADE.
 4. MECHANICALLY TAMP TO 85% PROCTOR.
 5. SLEEVE LOCATIONS SHALL BE MARKED ON THE TOP OF CURB WITH A SAWCUT OF TWO PARALLEL LINES THAT ARE 2\"/>

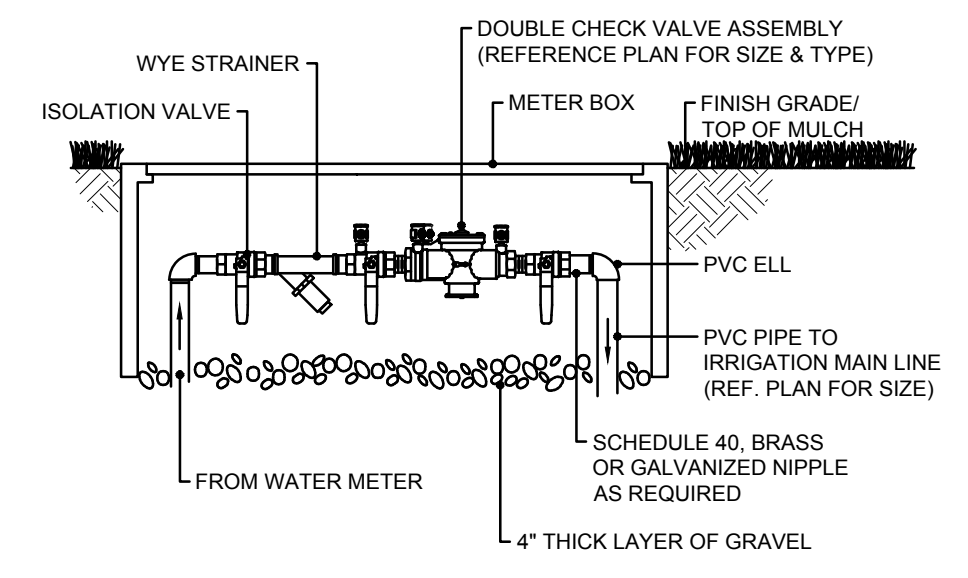

- 2 DOUBLE CHECK ASSEMBLY**
N.T.S.
1. INSTALL BACKFLOW PREVENTER AS REQUIRED BY LOCAL CODES AND HEALTH DEPARTMENT. VERIFY LOCAL REQUIREMENTS PRIOR TO INSTALLATION. PRIOR TO BACKFLOW PREVENTER, INSTALL A NOMINALLY SIZED ISOLATION VALVE.

SYMBOL	DESCRIPTION	MANUFACTURER	MODEL NO.
⬇	MULTI-STREAM BUBBLERS	HUNTER	PROS-06-PRS30 W/ MSBN50H NOZZLES
⬇	REMOTE CONTROL VALVE	HUNTER	ICV
⬇	1\"/>		

SYMBOL	DESCRIPTION	MANUFACTURER	MODEL NO.
⬇	HDL DRIFLINE	HUNTER	HDL-06-12-CV
⬇	LINE FLUSHING VALVE	HUNTER	AFV-B
⬇	PRESSURE OPERATOR INDICATOR	HUNTER	ECO-ID
⬇	DRIP CONTROL VALVE	HUNTER	ICZ-101-LF-25

SYMBOL	DESCRIPTION	MANUFACTURER	MODEL NO.
⬇	1\"/>		

NOTE TO CONTRACTOR:
1. PLAN SHEETS DO NOT SHOW EXISTING AND PROPOSED UTILITIES FOR CLARITY ONLY. CONTRACTOR TO LOCATE ALL UTILITIES PRIOR TO INSTALLATION. CONTRACTOR IS TO USE EXTREME CAUTION IN DIGGING AND TRENCHING TO AVOID EXISTING AND PROPOSED UTILITIES.

FLOW RANGE GPM	PIPE SIZE
0 - 6 GPM	3/4"
8 - 12 GPM	1"
12 - 22 GPM	1-1/4"
22 - 28 GPM	1-1/2"
28 + GPM	2"

NOTE:
1. ENTIRE SYSTEM SHALL BE INSTALLED PER STATE STANDARDS. MANUFACTURER'S SPECIFICATIONS AND ALL CITY CODES.
2. THIS DESIGN IS DIAGRAMMATIC. ALL PIPING, VALVES, AND OTHER EQUIPMENT SHOWN WITHIN PAVED AREAS OR OUT OF PROPERTY BOUNDARIES ARE FOR DESIGN CLARIFICATION ONLY. AND SHALL BE INSTALLED IN PLANTING AREAS WITHIN THE PROPERTY LINES OR LIMITS INDICATED ON PLAN. THE IRRIGATION CONTRACTOR SHALL VERIFY THE LOCATIONS OF ALL ABOVE GROUND IRRIGATION EQUIPMENT WITH THE OWNER'S AUTHORIZED REPRESENTATIVE PRIOR TO INSTALLATION, OR IRRIGATION CONTRACTOR MAY BE REQUIRED TO MOVE SUCH ITEMS AT HIS OWN COST.
3. VARIOUS AREAS ON PLAN ARE SHOWING SINGLE HEAD COVERAGE. IF OWNER SHOULD ELECT FOR FULL COVERAGE, CONTRACTOR TO PROCURE THE PROPER PERMITS AND BID ALTERNATE FOR THESE ADDITIONAL SPRAY HEADS, ZONES, AND CONTROLLER EXPANSION FOR THE SYSTEM.
4. IRRIGATION CONTRACTOR IS TO COORDINATE LOCATION AND PLACEMENT OF ALL IRRIGATION ITEMS WITH THE GENERAL CONTRACTOR. CONTRACTOR IS TO USE EXTREME CAUTION IN TRENCHING TO AVOID EXISTING AND PROPOSED UTILITIES. CONTRACTOR TO LOCATE ALL UTILITIES PRIOR TO IRRIGATION INSTALLATION.
5. IRRIGATION SPRAY NOZZLES TO BE ADJUSTED TO AVOID PAVEMENT, BUILDING, WALLS, FENCES, UTILITIES, EQUIPMENT, SIGNAGE, AND CALL BOX.
6. REFERENCE LANDSCAPE PLAN FOR LOCATION OF GRAVEL, STEEL EDGING AND ALL PROPOSED PLANT MATERIAL.
7. IN TURF AREAS (BOTH SOD AND HYDROMULCH AREAS) OUTSIDE OF IRRIGATION PERMANENT COVERAGE, CONTRACTOR TO PROVIDE TEMPORARY IRRIGATION UNTIL ESTABLISHED, TYP.
8. CONTRACTOR TO TAKE ALL NECESSARY MEASURES TO PREVENT WATER HAMMER AND SYSTEM COLLAPSE BY DISCHARGING AIR DURING STARTUP AND ALLOWING AIR TO ENTER DURING SHUTDOWN. INSTALL THRUST BLOCKS AND AIR/VACUUM RELIEF VALVES AS NECESSARY TO PROTECT MAINLINE SYSTEM. FOR 3 INCH AND LARGER MAINLINE, INSTALL JOINT RESTRAINTS AT TURNS. INSTALL PER MANUFACTURER'S RECOMMENDATIONS.
9. ALL MAINLINE PIPING 3 INCHES AND LARGER SHALL BE BELL AND GASKETED CLASS 200 PVC PIPE. SDR 21. INSTALL PER MANUFACTURER'S RECOMMENDATIONS. CONTACT MANUFACTURER OR DISTRIBUTOR FOR PRODUCT DEMONSTRATION.
10. GROUP VALVES IN FIELD AS NECESSARY FOR MAINLINE SIZING. CENTER FEED LATERALS WHEN POSSIBLE.

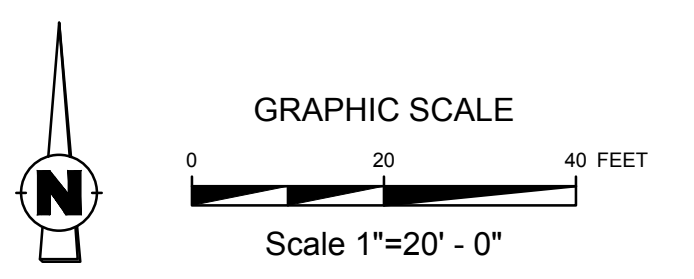
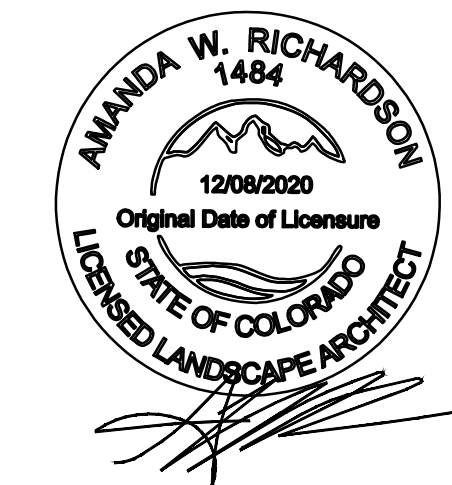

AWR
AWR Designs, LLC
P.O. Box 1746
Alledo, Texas 76008
amanda@awr-designs.com
c. 512.517.5589

CALL UTILITY NOTIFICATION
CENTER OF COLORADO
1-800-922-1987
CALL 2-BUSINESS DAYS IN ADVANCE
BEFORE YOU DIG, GRADE, OR EXCAVATE
FOR THE MARKING OF UNDERGROUND
MEMBER UTILITIES.

811
Know what's below.
Call before you dig.
THE LOCATIONS OF EXISTING UNDERGROUND UTILITIES ARE SHOWN ON AN APPROXIMATE BASIS ONLY. THE CONTRACTOR SHALL DETERMINE THE EXACT LOCATION OF ALL EXISTING UTILITIES BEFORE COMMENCING WORK. ANY AND ALL DAMAGES WHICH MIGHT BE OCCURRED BY THE CONTRACTOR'S FAILURE TO EXACTLY LOCATE AND PRESERVE ANY AND ALL UNDERGROUND UTILITIES.

NOTICE:
CONSTRUCTION SITE SAFETY IS THE SOLE RESPONSIBILITY OF THE CONTRACTOR. NEITHER THE OWNER NOR THE PROJECTOR SHALL BE LIABLE FOR ANY AND ALL DAMAGES WHICH MIGHT BE OCCURRED BY THE CONTRACTOR'S FAILURE TO EXACTLY LOCATE AND PRESERVE ANY AND ALL UNDERGROUND UTILITIES.

24 HOUR EMERGENCY CONTACT

ATWELL
866.850.4200 www.atwell-group.com
9001 AIRPORT FREEWAY, SUITE 660
NORTH RICHLAND HILLS, TX 76180
972.636.9860

LOT 1A: PARKER POINTE SUBD. FILING NO. 1. AMEND. NO. 1
S. PARKER RD & STROH RD
PARKER
DOUGLAS COUNTY, COLORADO

BLACK ROCK COFFEE BAR
13135 DECLAN DRIVE
IRRIGATION PLAN

DATE: 2025-8-21

REVISIONS

DRAWN BY: K. SARWAR
CHECKED BY: N. SALAZAR
PROJECT MANAGER: N. SALAZAR
JOB #: 24003198
FILE CODE: ##
SHEET NO: L2.01

SECTION 32 8423 - UNDERGROUND IRRIGATION SLEEVES AND UTILITY CONDUITS

- PART 1 - GENERAL**
- 1.1 DESCRIPTION
- A. PROVIDE UNDERGROUND IRRIGATION SLEEVES AS INDICATED ON THE DRAWINGS.
- 1.2 RELATED WORK
- A. SECTION 32 8424 - IRRIGATION SYSTEM.
- 1.3 REFERENCE STANDARDS
- A. AMERICAN STANDARD FOR TESTING AND MATERIALS (ASTM) - LATEST EDITION.
- PART 2 - MATERIALS**
- 2.1 GENERAL
- A. POLYVINYL CHLORIDE PIPE (PVC) - SCHEDULE 40 SHALL BE USED FOR ALL SLEEVING PURPOSES.
- B. PVC PIPES SHALL BE MARKED WITH SDR NUMBER, ASTA STANDARD NUMBER, AND THE NSF SEAL.
- C. SOLVENT SHALL BE USED AS RECOMMENDED BY MANUFACTURER TO MAKE SOLVENT WELDED JOINTS. PIPE AND FITTINGS SHOULD BE CLEANED BEFORE APPLYING SOLVENT.
- PART 3 - EXECUTION**
- 3.1 INSTALLATION
- A. A MINIMUM OF TWENTY FOUR (24) INCHES COVER SHALL BE PROVIDED OVER THE TOP OF SLEEVE FROM FINISH GRADE.
- B. SLEEVES SHALL BE EXTENDED ONE (1) FOOT PAST THE EDGE OF PAVEMENT OF WALLS. INSTALL A NINETY DEGREE ELBOW ON EACH SLEEVE AND ADD ADDITIONAL LENGTH TO EXTEND ABOVE FINISH GRADE BY TWELVE (12) INCHES. CAP PIPE ENDS.
- 3.2 BACKFILL
- A. BACKFILL SHALL BE PLACED OVER SLEEVES IN SIX (6) INCH LIFTS. SOIL SHALL BE TAMPED INTO PLACE, TAKING CARE TO NOT DAMAGE SLEEVE.
- B. REPAIR ANY DAMAGE FROM IMPROPER COMPACTION.
- END OF SECTION

SECTION 32 8424 - IRRIGATION SYSTEM

- PART 1 - GENERAL**
- 1.1 DESCRIPTION
- A. PROVIDE A COMPLETE IRRIGATION SYSTEM INSTALLATION AS DETAILED AND SPECIFIED. THIS SHALL INCLUDE FURNISHING ALL LABOR, MATERIAL, EQUIPMENT AND SERVICES NECESSARY TO PROVIDE COMPLETE INSTALLATION. WORK INCLUDES:
- a. TRENCHING
- b. BACKFILL
- c. AUTOMATIC CONTROLLED SYSTEM
- d. AS BUILT DRAWINGS
- B. SLEEVING AS SHOWN SHALL BE FURNISHED BY THE GENERAL CONTRACTOR.
- C. METER AND POWER SHALL BE PROVIDED BY THE GENERAL CONTRACTOR.
- 1.2 RELATED WORK
- C. REFERENCE IRRIGATION PLANS FOR CONTROLLER, HEAD AND ALL VALVE LOCATIONS.
- D. REFERENCE LANDSCAPE PLANS, NOTES, DETAILS FOR ADDITIONAL REQUIREMENTS.
- E. SECTION 32 9300 - LANDSCAPE
- F. SECTION 32 8423 - UNDERGROUND IRRIGATION SLEEVE AND UTILITY CONDUITS

1.3 REFERENCE STANDARDS

- A. AMERICAN STANDARD FOR TESTING AND MATERIALS (ASTM) - LATEST EDITION.
- 1.4 QUALITY ASSURANCE AND REQUIREMENTS
- A. PERMITS AND FEES: THE CONTRACTOR SHALL OBTAIN AND PAY FOR ANY PERMITS NECESSARY AND ALL OBSERVATIONS AS REQUIRED.
- B. MANUFACTURER'S DIRECTIONS: MANUFACTURER'S DIRECTIONS AND DETAILED DRAWINGS SHALL BE FOLLOWED IN ALL CASES WHERE THE MANUFACTURERS OF ARTICLES USED IN THIS CONTRACT FURNISH DIRECTIONS COVERING POINTS NOT SHOWN IN THE DRAWINGS AND SPECIFICATIONS.
- C. ORDINANCES, CODES, AND REGULATIONS: ALL LOCAL, MUNICIPAL AND STATE LAWS, AND RULES AND REGULATIONS GOVERNING OR RELATING TO ANY PORTION OF THIS WORK ARE HEREBY INCORPORATED INTO AND MADE A PART OF THESE SPECIFICATIONS, AND THEIR PROVISIONS SHALL BE CARRIED OUT BY THE CONTRACTOR. ANYTHING CONTAINED IN THESE SPECIFICATIONS SHALL NOT BE CONSTRUED TO CONFLICT WITH ANY OF THE ABOVE RULES AND REGULATIONS AND REQUIREMENTS OF THE SAME.
- D. HOWEVER, WHEN THESE SPECIFICATIONS AND DRAWINGS CALL FOR OR DESCRIBE MATERIALS, WORKMANSHIP, OR CONSTRUCTION OF A BETTER QUALITY, HIGHER STANDARD OR LARGER SIZE THAN IS REQUIRED BY THE ABOVE RULES AND REGULATIONS, THESE SPECIFICATIONS AND DRAWINGS SHALL TAKE PRECEDENCE.
- 1.5 SCHEDULE OF MATERIALS
- A. MATERIALS LIST:
- a. ALL EQUIPMENT MANUFACTURERS AND MODEL NUMBERS SHALL BE AS NOTED ON THE PLANS.
- b. THE CONTRACTOR SHALL FURNISH THE ARTICLES, EQUIPMENT, MATERIALS, OR PROCESSES SPECIFIED BY NAME IN THE DRAWINGS AND SPECIFICATIONS. NO SUBSTITUTION WILL BE ALLOWED WITHOUT PRIOR WRITTEN APPROVAL OF THE LANDSCAPE ARCHITECT.
- c. A COMPLETE MATERIAL LIST OF EQUIPMENT SHALL BE SUBMITTED BEFORE PERFORMING ANY WORK. SUBMITTALS SHOULD INCLUDE ALL MANUFACTURERS' SPECIFICATIONS AND LITERATURE FOR APPROVAL BY THE LANDSCAPE ARCHITECT PRIOR TO INSTALLATION.
- d. EQUIPMENT OR MATERIALS INSTALLED OR FURNISHED WITHOUT PRIOR APPROVAL OF THE LANDSCAPE ARCHITECT MAY BE REJECTED.
- e. APPROVAL OF ANY ITEM, ALTERNATE OR SUBSTITUTE INDICATES ONLY THAT THE PRODUCT OR PRODUCTS APPARENTLY MEET THE REQUIREMENTS OF THE DRAWINGS AND SPECIFICATIONS ON THE BASIS OF THE INFORMATION OR SAMPLES SUBMITTED.
- f. MANUFACTURER'S WARRANTIES SHALL NOT RELIEVE THE CONTRACTOR OF HIS LIABILITY UNDER THE GUARANTEE. SUCH WARRANTIES SHALL ONLY SUPPLEMENT THE GUARANTEE.

- 1.4 RECORD AND AS BUILT DRAWINGS/SUBMITTALS
- A. CONTRACTOR SHALL PROVIDE AND KEEP UP TO DATE AND COMPLETE "AS-BUILT" RECORD SET OF PRINTS.
- B. CONTRACTOR SHOULD USE ALL SYMBOLS AND NOTATIONS CONSISTENT WITH THE ORIGINAL DRAWINGS.
- C. IN "AS-BUILT" DRAWINGS, CONTRACTOR SHALL LOCATE:
- a. CONNECTION TO EXISTING WATER LINES
- b. CONNECTION TO ELECTRICAL POWER
- c. GATE VALVES
- d. ROUTING OF SPRINKLER PRESSURE LINES
- e. SPRINKLER CONTROL VALVES
- f. QUICK COUPLING VALVES
- g. OTHER RELATED EQUIPMENT
- D. SUBMIT COMPLETED TRACINGS PRIOR TO FINAL ACCEPTANCE. DATE AND SIGN ALL DRAWINGS.
- E. EQUIPMENT TO BE FURNISHED:

- a. SUPPLY AS PART OF THIS CONTRACT THE FOLLOWING TOOLS:
- i. QUICK COUPLING KEYS, THREE (3) WITH BOILER DRAINS ATTACHED USING BRASS REDUCER.
- ii. THREE (3) KEYS FOR EACH AUTOMATIC CONTROLLER
- b. THE ABOVE MENTIONED EQUIPMENT SHALL BE TURNED OVER TO THE OWNER AT THE CONCLUSION OF THE PROJECT.
- F. THE IRRIGATION CONTRACTOR SHOULD DEMONSTRATE THAT THE FINAL INSTALLED SYSTEM WILL OPERATE ACCORDING TO THE INTENT OF THE DESIGNED AND SPECIFIED SYSTEM. IRRIGATION CONTRACTOR SHALL GUARANTEE 100% COVERAGE TO ALL AREAS TO BE IRRIGATED.
- 1.5 MAINTENANCE AND GUARANTEE
- A. MAINTENANCE AND WORKMANSHIP SHALL BE GUARANTEED FULLY FOR ONE (1) YEAR AFTER FINAL ACCEPTANCE.
- B. PROVIDE MAINTENANCE OF SYSTEM, CLEANING AND ADJUSTMENT OF THE HEADS, FOR ONE (1) YEAR AFTER COMPLETION OF INSTALLATION.
- C. GUARANTEE IS LIMITED TO REPAIR AND REPLACEMENT OF DEFECTIVE MATERIALS AND WORKMANSHIP, INCLUDING THE REPAIR OF BACKFILL SETTLEMENT.
- 1.6 TESTING
- A. PERFORM TESTING REQUIRED WITH OTHER TRADES INCLUDING EARTHWORK, PAVING, PLUMBING, ETC. TO AVOID CUTTING, PATCHING OR BORING.
- B. WATER PRESSURE SHOULD BE FOUND PRIOR TO STARTING CONSTRUCTION. DETERMINE/CONFIRM THAT STATIC WATER PRESSURE IS MORE THAN THE WATER PRESSURE NEEDED FOR THE SYSTEM TO FUNCTION PROPERLY. IF STATIC PRESSURE IS LESS THAN THE DESIGN PRESSURE NEEDED, DO NOT START WORK UNTIL THE LANDSCAPE ARCHITECT IS NOTIFIED.
- 1.7 COORDINATION
- A. COORDINATE INSTALLATION OF ALL PRODUCTS, INCLUDING EARTHWORK, PAVING AND PLUMBING.
- B. COORDINATE TO ENSURE THAT ELECTRICAL POWER SOURCE IS IN PLACE.
- C. COORDINATE INSTALLATION WITH WORK SPECIFIED IN OTHER SECTIONS.
- D. COORDINATE WITH THE LANDSCAPE CONTRACTOR TO ENSURE PLANT MATERIAL IS UNIFORMLY WATERED IN ACCORDANCE WITH INTENT SHOWN ON DRAWINGS.

- PART 2 - PRODUCTS**
- 2.1 MATERIALS
- B. REFER TO CONSTRUCTION DRAWINGS AND NOTES.
- C. SPRINKLER HEADS IN LAWN AREAS AS SPECIFIED ON PLAN
- D. PVC PIPE: CLASS 200 SPR 21
- E. COPPER TUBING (FOR CITY CONNECTIONS): TYPE "M"
- F. 24V WIRE - SIZE 14, TYPE UF
- G. ELECTRIC VALVES TO BE ALL PLASTIC CONSTRUCTION AS INDICATED ON PLANS.
- H. REFER TO DRAWING FOR BACKFLOW PREVENTION LOCATION - COORDINATE EXACT LOCATION WITH THE GENERAL CONTRACTOR.

- PART 3 - EXECUTION**
- 3.1 INSTALLATION
- A. SITE CONDITIONS:
- a. ALL SCALED DIMENSIONS ARE APPROXIMATE. THE CONTRACTOR SHALL CHECK AND VERIFY ALL SIZE DIMENSIONS.
- b. EXERCISE EXTREME CARE IN EXCAVATING AND WORKING NEAR UTILITIES. CONTRACTOR SHALL BE RESPONSIBLE FOR DAMAGES TO UTILITIES WHICH ARE CAUSED BY ANY OF HIS OPERATIONS OR NEGLIGENCE.
- c. COORDINATE INSTALLATION OF IRRIGATION MATERIALS, INCLUDING PIPE, SO THERE SHALL BE NO

INTERFERENCE WITH UTILITIES OR OTHER CONSTRUCTION DIFFICULTY IN PLANTING TREES, SHRUBS, AND GROUNDCOVERS. COORDINATE WORK WITH OTHER SITE CONTRACTORS.

- 3.2 PREPARATION
- A. PHYSICAL LAYOUT:
- a. PIPING AND HEAD LAYOUT AS SHOWN ON PLANS IS SCHEMATIC ONLY. ALL PIPES TO BE INSTALLED DIRECTLY BEHIND CURBS, WALLS AND WALLS WHEREVER POSSIBLE.
- b. PRIOR TO INSTALLATION CONTRACTOR SHALL STAKE OUT ALL PRESSURE SUPPLY LINES, ROUTING AND LOCATION OF SPRINKLER HEADS.
- c. ALL LAYOUTS SHALL BE APPROVED BY THE LANDSCAPE ARCHITECT OR OWNER'S REPRESENTATIVE PRIOR TO INSTALLATION.
- B. WATER SUPPLY:
- a. IRRIGATION SYSTEM SHALL BE CONNECTED TO WATER SUPPLY POINTS OF CONNECTION AS INDICATED ON THE DRAWINGS.
- b. CONNECTIONS SHALL BE MADE AT APPROXIMATE LOCATIONS AS SHOWN ON DRAWINGS. CONTRACTOR SHALL VERIFY IN FIELD AND BE RESPONSIBLE FOR MINOR CHANGES CAUSED BY ACTUAL SITE CONDITIONS.

- 3.3 INSTALLATION
- A. TRENCHING
- a. DIG TRENCHES STRAIGHT 6" WIDE WITH NEAR VERTICAL SIDE AND SUPPORT PIPE CONTINUOUSLY ON BOTTOM OF TRENCH. REMOVE LUMBER, RUBBISH, LARGE ROCKS ETC. FROM TRENCHES. LAY PIPE TO AN EVEN GRADE - WITH A FIRM, UNIFORM BEARING FOR ENTIRE LENGTH OF PIPE.
- b. REMOVE FOREIGN MATTER OR DIRT FROM INSIDE OF PIPE BEFORE WELDING AND KEEP PIPING CLEAN BY ANY MEANS POSSIBLE DURING AND AFTER LAYING OF PIPE.
- c. PROVIDE A MINIMUM OF EIGHTEEN (18) INCHES OF COVER FOR ALL PRESSURE SUPPLY LINES.
- d. PROVIDE A MINIMUM OF TWELVE (12) INCHES OF COVER FOR ALL NON-PRESSURE LINES.
- e. PROVIDE A MINIMUM COVER OF EIGHTEEN (18) INCHES FOR ALL CONTROL WIRING.
- f. NO MACHINE TRENCHING, UNLESS APPROVED BY THE LANDSCAPE ARCHITECT, SHALL BE DONE WITHIN DRIP LINE OF EXISTING TREES. TRENCHING SHOULD BE DONE BY HAND, TUNNELING OR BORING OR OTHER METHODS APPROVED BY THE LANDSCAPE ARCHITECT. IT SHOULD BE UNDERSTOOD THAT PIPING LAYOUT IS DIAGRAMMATIC AND PIPING SHALL BE ROUTED AROUND TREES AND SHRUBS IN SUCH A MANNER TO AVOID DAMAGE TO PLANTS.
- B. BACKFILL
- a. TRENCHES SHALL NOT BE BACKFILLED UNTIL ALL REQUIRED TESTS ARE PERFORMED. TRENCHES SHALL BE CAREFULLY BACKFILLED WITH THE EXCAVATED MATERIALS APPROVED FOR BACKFILLING, CONSISTING OF EARTH, LOAM, SANDY CLAY, SAND OR OTHER APPROVED MATERIALS, FREE FROM LARGE CLODS, STONES OR STICKS.
- b. IF SETTLEMENT OCCURS AND SUBSEQUENT ADJUSTMENTS IN PIPE, VALVES, SPRINKLER HEADS, LAWN OR PLANTING OR OTHER CONSTRUCTION ARE NECESSARY, THE CONTRACTOR SHALL MAKE ALL REQUIRED ADJUSTMENTS WITHOUT THE COST TO THE OWNER.
- C. TRENCHING AND BACKFILL UNDER PAVING:
- a. ALL IRRIGATION MAIN LINE AND LATERAL LINES OR WIRING LOCATED UNDER AREAS WHERE PAVING, ASPHALTIC PAVING, OR CONCRETE SHALL BE INSTALLED IN SCHEDULE 40 PVC SLEEVES OF ADEQUATE SIZE. SEE SECTION 32 8423.
- D. ASSEMBLIES
- a. INSTALL ALL ASSEMBLIES SPECIFIED HEREIN IN ACCORDANCE WITH RESPECTIVE DETAILS. IN ABSENCE OF DETAIL DRAWINGS OR SPECIFICATIONS, PERFORM SUCH WORK IN ACCORDANCE WITH BEST STANDARD PRACTICES OR MANUFACTURER'S RECOMMENDATIONS AS APPROVED BY THE LANDSCAPE ARCHITECT.
- b. MAKE SOLVENT WELDED JOINTS USING ONLY THE SOLVENT RECOMMENDED BY THE MANUFACTURER. PIPES AND FITTINGS SHOULD BE CLEANED OF ALL DIRT AND DUST AND MOISTENED

- BEFORE APPLYING SOLVENT.
- c. ON PVC TO METAL CONNECTIONS, THE CONTRACTOR SHALL WORK METAL CONNECTIONS FIRST. USE NON HARDENING PIPE DOOR OR TEFLON TAPE ON THREADED PVC ADAPTERS INTO WHICH PIPE MAY BE WELDED. LIGHT WRENCH PRESSURE IS ALL THAT IS REQUIRED, USE THREADED PVC ADAPTERS INTO WHICH THE PIPE MAY BE WELDED.
- E. LINE CLEARANCE: ALL LINES SHALL HAVE A MINIMUM CLEARANCE OF SIX (6) INCHES FROM EACH OTHER AND FROM OTHER TRADES. PARALLEL LINES SHALL NOT BE DIRECTLY INSTALLED ONE OVER THE OTHER.
- F. WIRING: SUPPLY WIRE FROM THE AUTOMATIC CONTROLLER TO ALL THE VALVES. A SEPARATE WIRE IS REQUIRED TO EACH ELECTRIC VALVE. A COMMON NEUTRAL WIRE IS ALSO REQUIRED FROM EACH CONTROL TO EACH OF THE VALVES. BUNDLE MULTIPLE WIRES AND TAPE THEM TOGETHER AT TEN FOOT INTERVALS. EXPANSION COILS OF TEN INCHES SHALL BE INSTALLED APPROXIMATELY EVERY 100 FEET. MAKE ALL SPLICES WATERPROOF.
- G. AUTOMATIC CONTROLLER: INSTALL AS PER MANUFACTURER'S SPECIFICATIONS AND INSTRUCTIONS. REMOVE CONTROL VALVES SHALL BE CONNECTED TO CONTROLLER IN NUMERICAL SEQUENCE AS SHOWN ON THE DRAWINGS. EACH REMOVE CONTROL VALVE SHALL BE WIRED TO ONE STATION OF THE CONTROLLER.
- H. REMOTE CONTROL VALVES:
- a. INSTALL WHERE SHOWN ON DRAWINGS AND DETAILS. VALVES SHALL BE SIZED ACCORDING TO THE DRAWINGS.
- b. INSTALL IN A LEVEL POSITION IN ACCORDANCE TO MANUFACTURER'S SPECIFICATIONS.
- c. WHEN GROUPED TOGETHER, ALLOW AT LEAST TWELVE (12) INCHES BETWEEN VALVES. INSTALL EACH REMOTE CONTROL VALVE IN A SEPARATE VALVE BOX. EACH VALVE NUMBER AND ITS CONTROLLER LETTER SHALL BE STENCILED INSIDE VALVE BOX TOP WITH EXTERIOR PAINT.

- I. FLUSHING OF SYSTEM:
- a. AFTER ALL NEW SPRINKLER PIPE LINES AND RISERS ARE IN PLACE AND CONNECTED, ALL NECESSARY WORK HAS BEEN COMPLETED, AND PRIOR TO INSTALLATION OF SPRINKLER HEADS, THE CONTROL VALVES SHALL BE OPENED AND A FULL HEAD OF WATER USED TO FLUSH OUT THE SYSTEM.
- b. SPRINKLER HEADS SHALL BE INSTALLED ONLY AFTER FLUSHING OF THE SYSTEM HAS BEEN ACCOMPLISHED.
- J. SPRINKLER HEADS:
- a. INSTALL HEADS AS DESIGNED ON THE DRAWINGS. MAKE APPROPRIATE ADJUSTMENTS TO HEAD LAYOUT TO ACCOMMODATE FOR ACTUAL FIELD CONDITIONS.
- b. SPACING OF HEADS SHALL NOT EXCEED THE MAXIMUM INDICATED ON THE DRAWINGS. IN NO CASE SHALL THE SPACING EXCEED THE MAXIMUM RECOMMENDED BY THE MANUFACTURER.
- c. ALL SPRINKLERS TO ATTACH TO LATERAL LINES WITH FLEXIBLE CONNECTORS. REFERENCE DETAILS ON DRAWINGS.

- 3.4 TESTING
- A. THE CONTRACTOR SHALL TEST SPRINKLER MAIN FOR TWELVE TO FOURTEEN HOURS UNDER NORMAL PRESSURE. IF LEAKS ARE PRESENT, REPLACE JOINT OR JOINS AND REPEAT TEST.
- B. A COMPLETE TEST SHALL BE MADE PRIOR TO BACKFILLING. BACKFILLING MATERIALS MAY BE PLACED IN TRENCHES IN LIFTS TO ENSURE STABILITY OF THE LINE UNDER THE PRESSURE OF BACKFILL. IN EACH CASE, LEAVE FITTINGS AND COUPLINGS OPEN TO VISUALLY INSPECT FOR FULL PERIOD OF TEST.
- C. WHEN SYSTEM IS COMPLETE, A COVERAGE TEST SHALL BE PERFORMED IN THE PRESENCE OF THE LANDSCAPE ARCHITECT OR OWNER'S REPRESENTATIVE. IT SHALL BE DETERMINED IF THE WATER COVERAGE FOR ALL PLANTING AREAS IS COMPLETE AND ADEQUATE. FURNISH ALL MATERIALS AND PERFORM ALL WORK REQUIRED TO CORRECT ANY INADEQUACIES OF COVERAGE.
- D. UPON COMPLETION OF EACH PHASE OF WORK, THE ENTIRE SYSTEM SHOULD BE TESTED AND ADJUSTED TO MEET SITE REQUIREMENTS.
- END OF SECTION

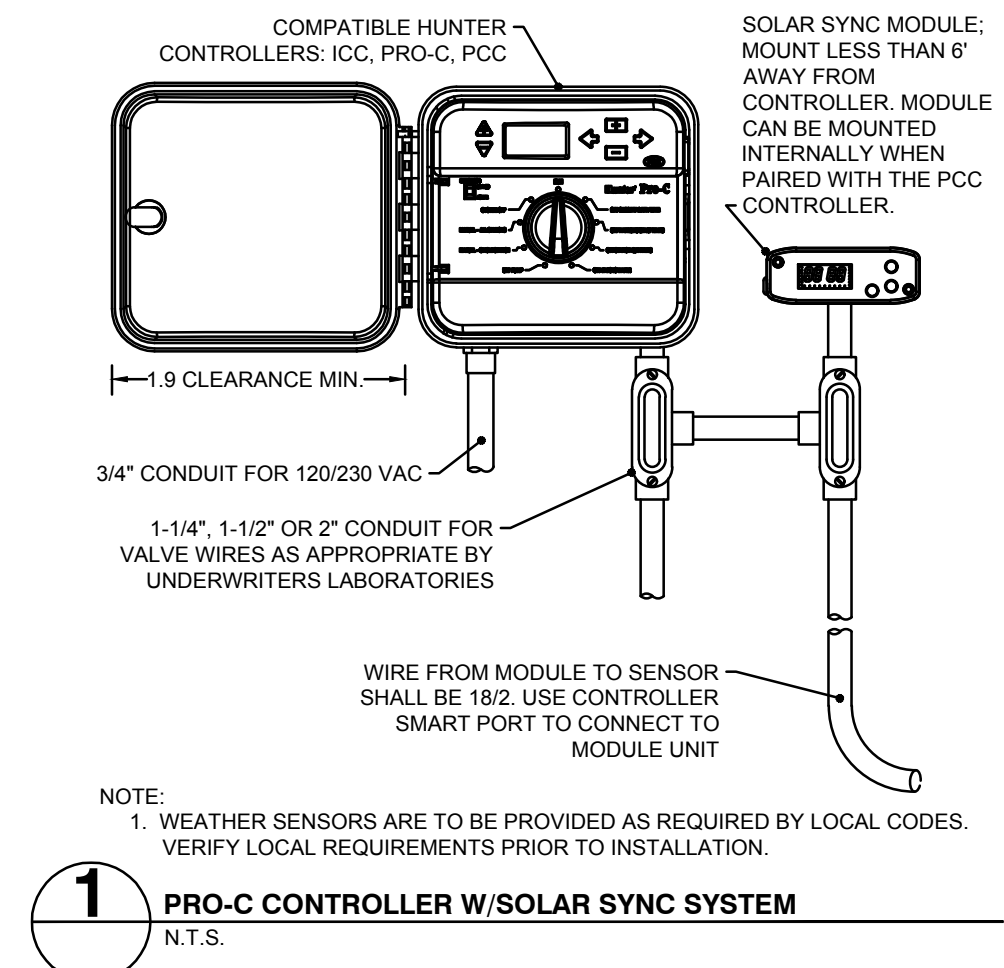

1 PRO-C CONTROLLER W/SOLAR SYNC SYSTEM
N.T.S.

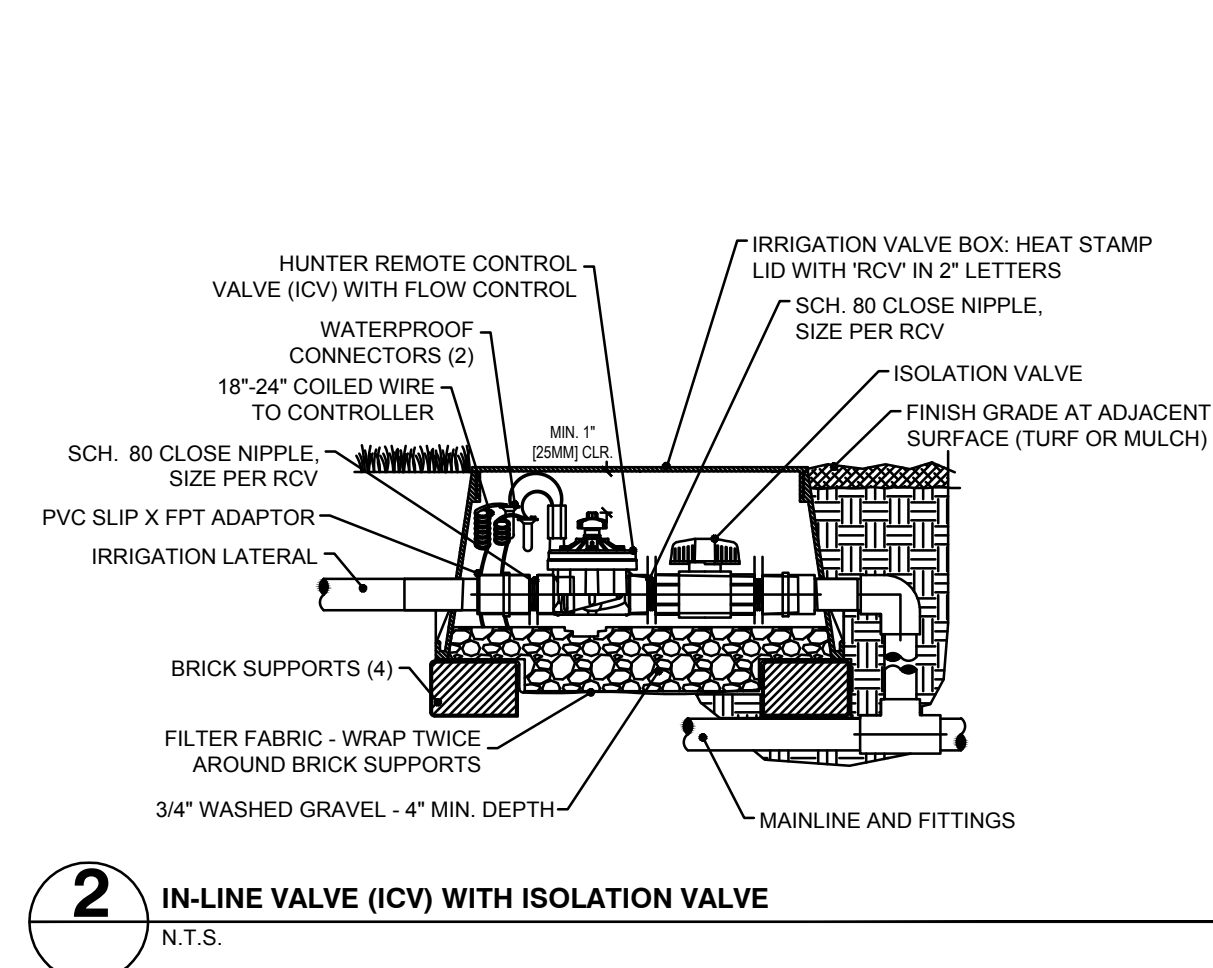

2 IN-LINE VALVE (ICV) WITH ISOLATION VALVE
N.T.S.

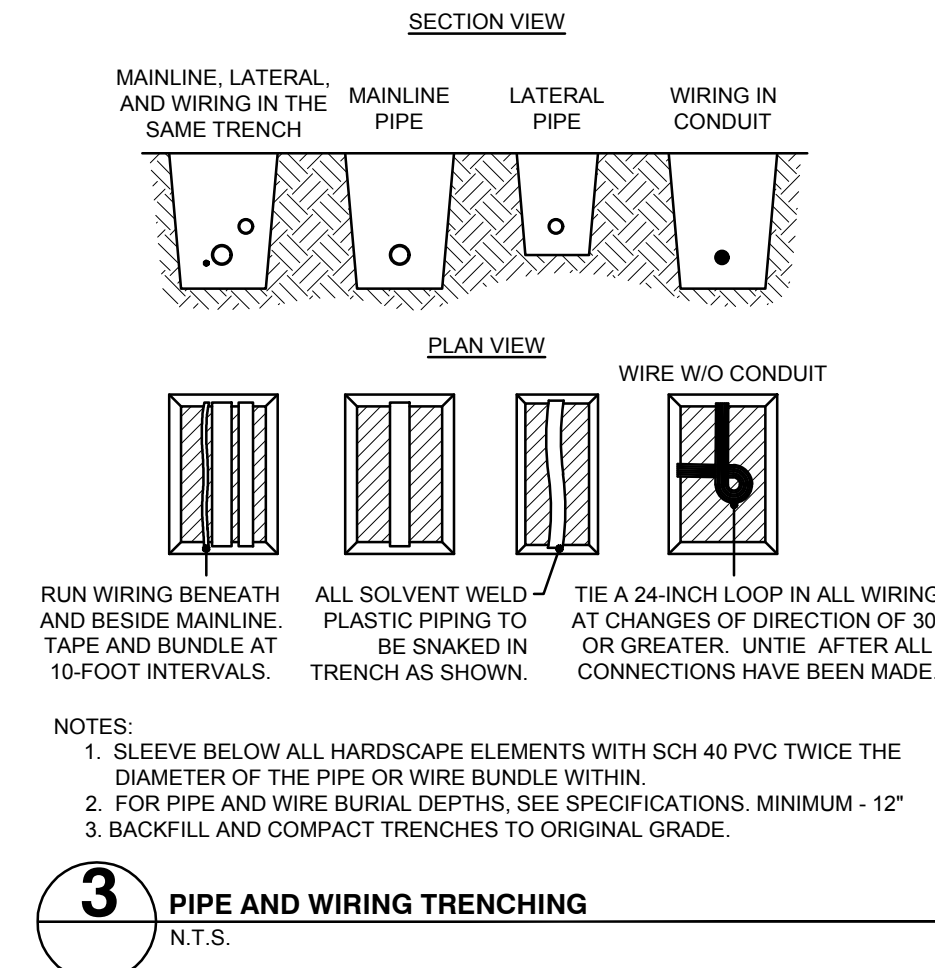

3 PIPE AND WIRING TRENCHING
N.T.S.

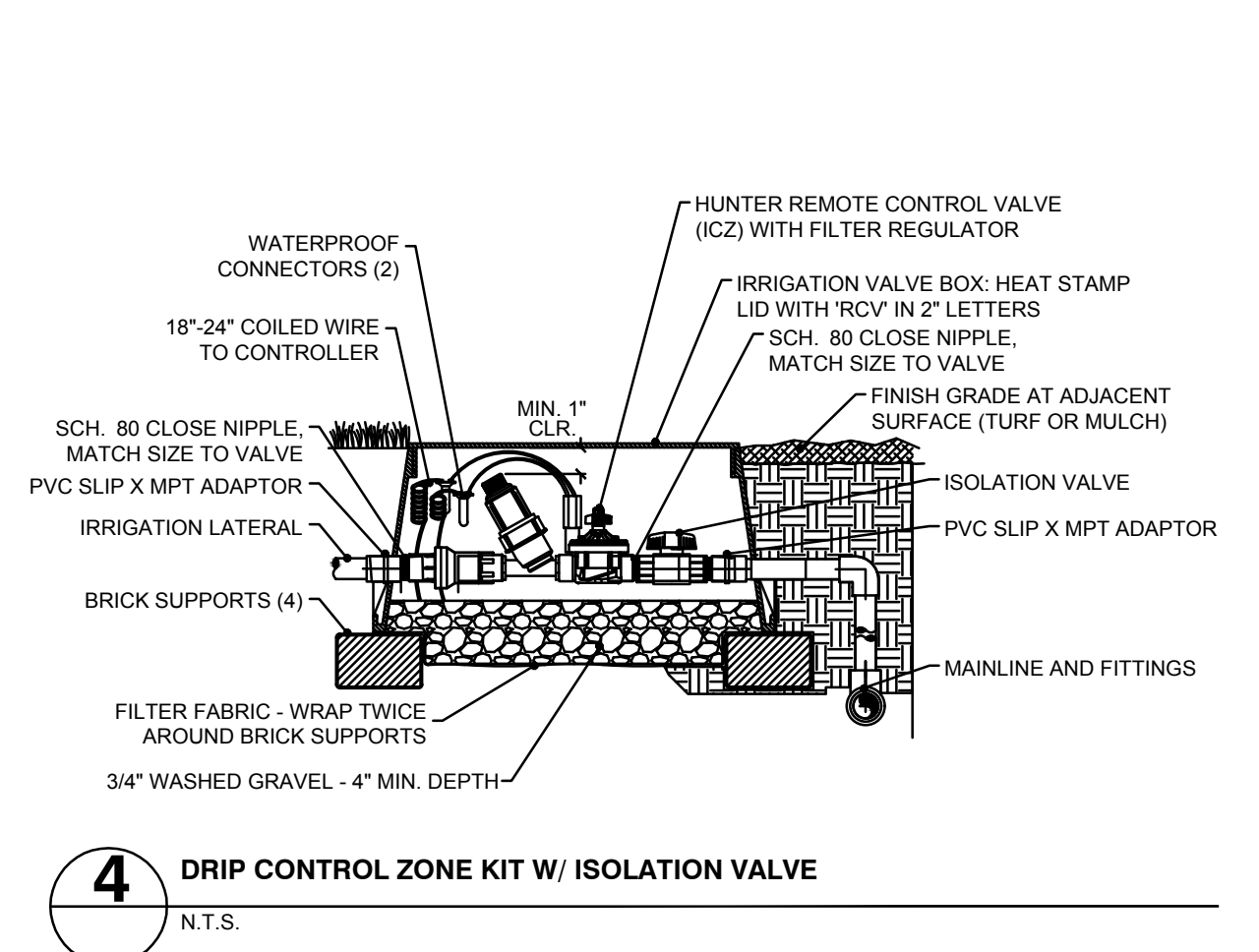

4 DRIP CONTROL ZONE KIT W/ ISOLATION VALVE
N.T.S.

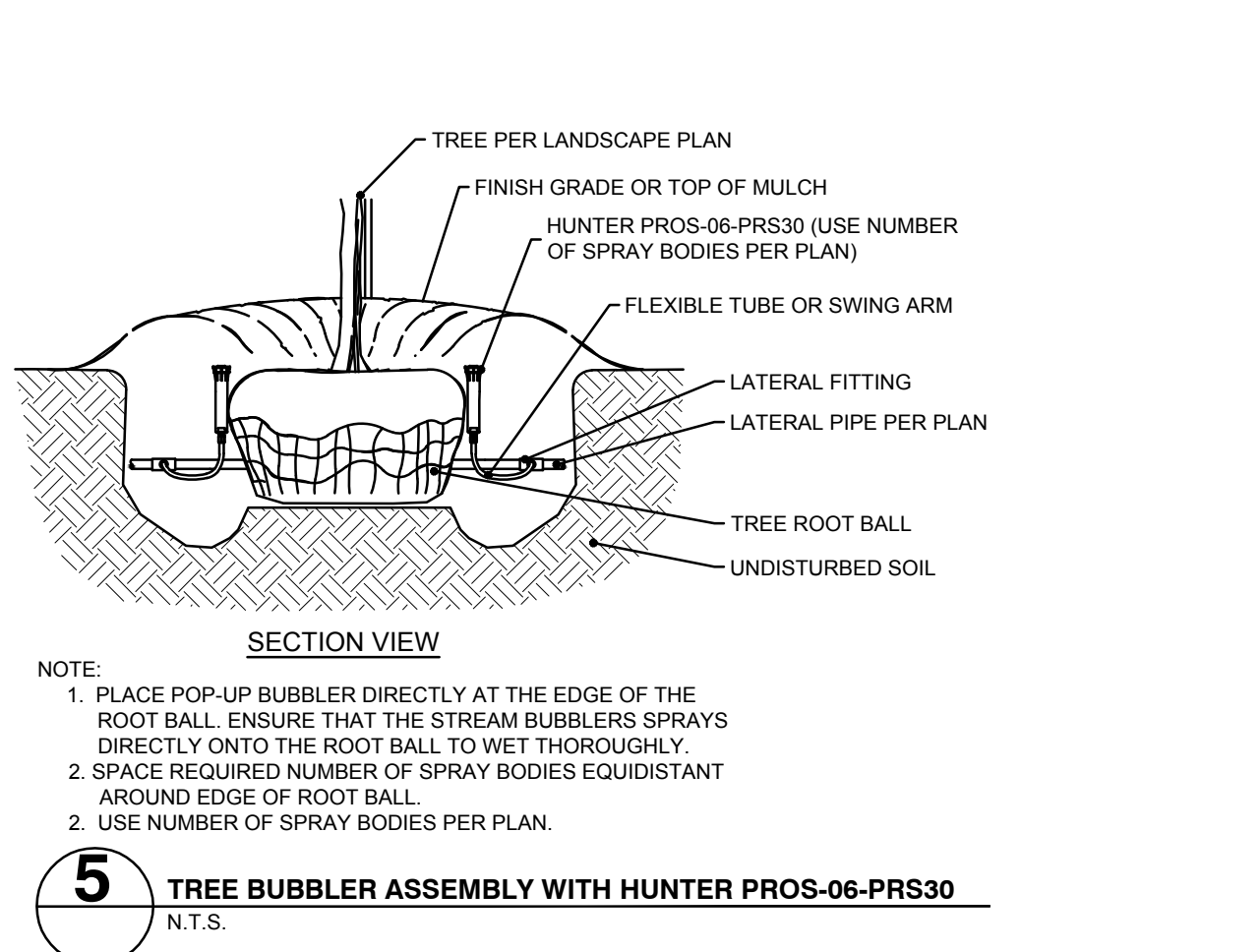

5 TREE BUBBLER ASSEMBLY WITH HUNTER PROS-06-PRS30
N.T.S.

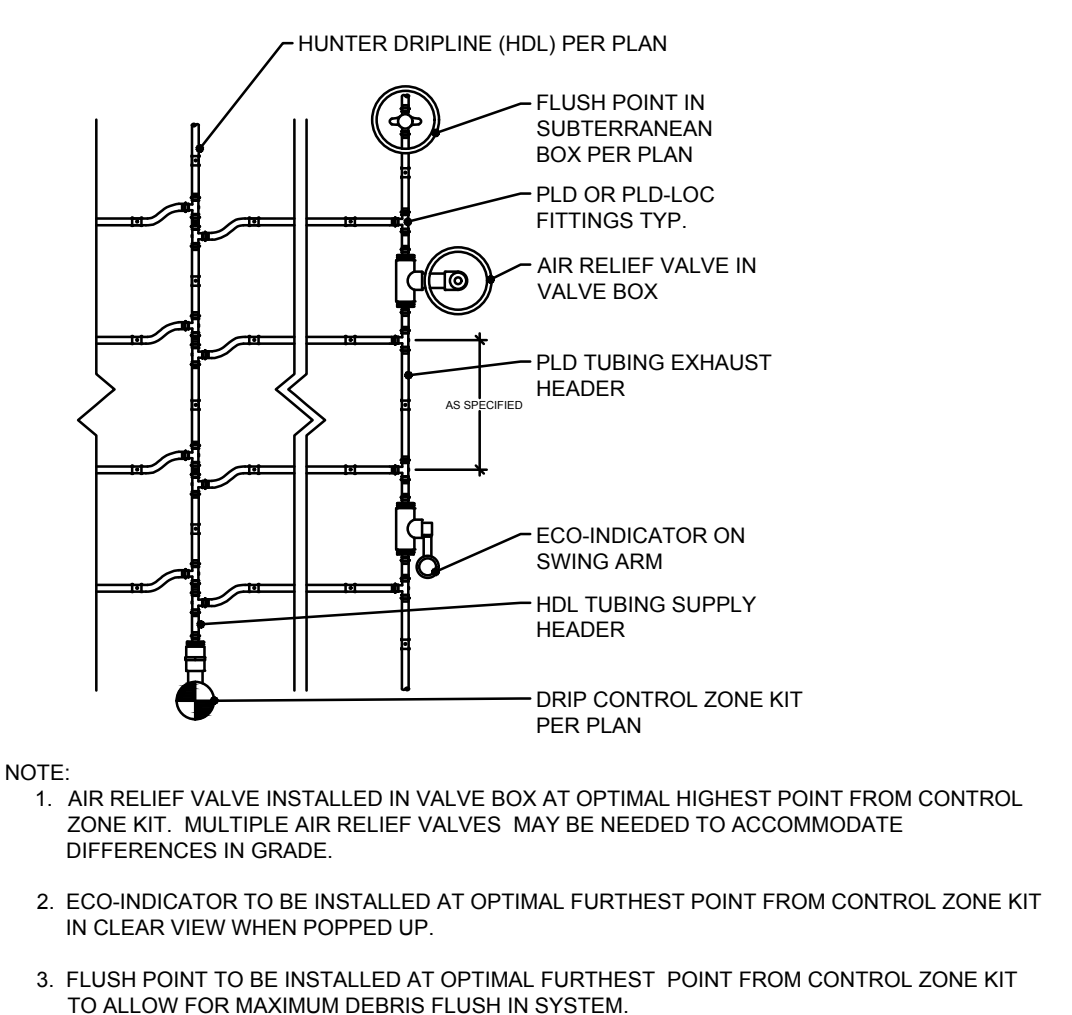

6 HUNTER DRIPLINE- PLANTING BED CENTER FEED
N.T.S.

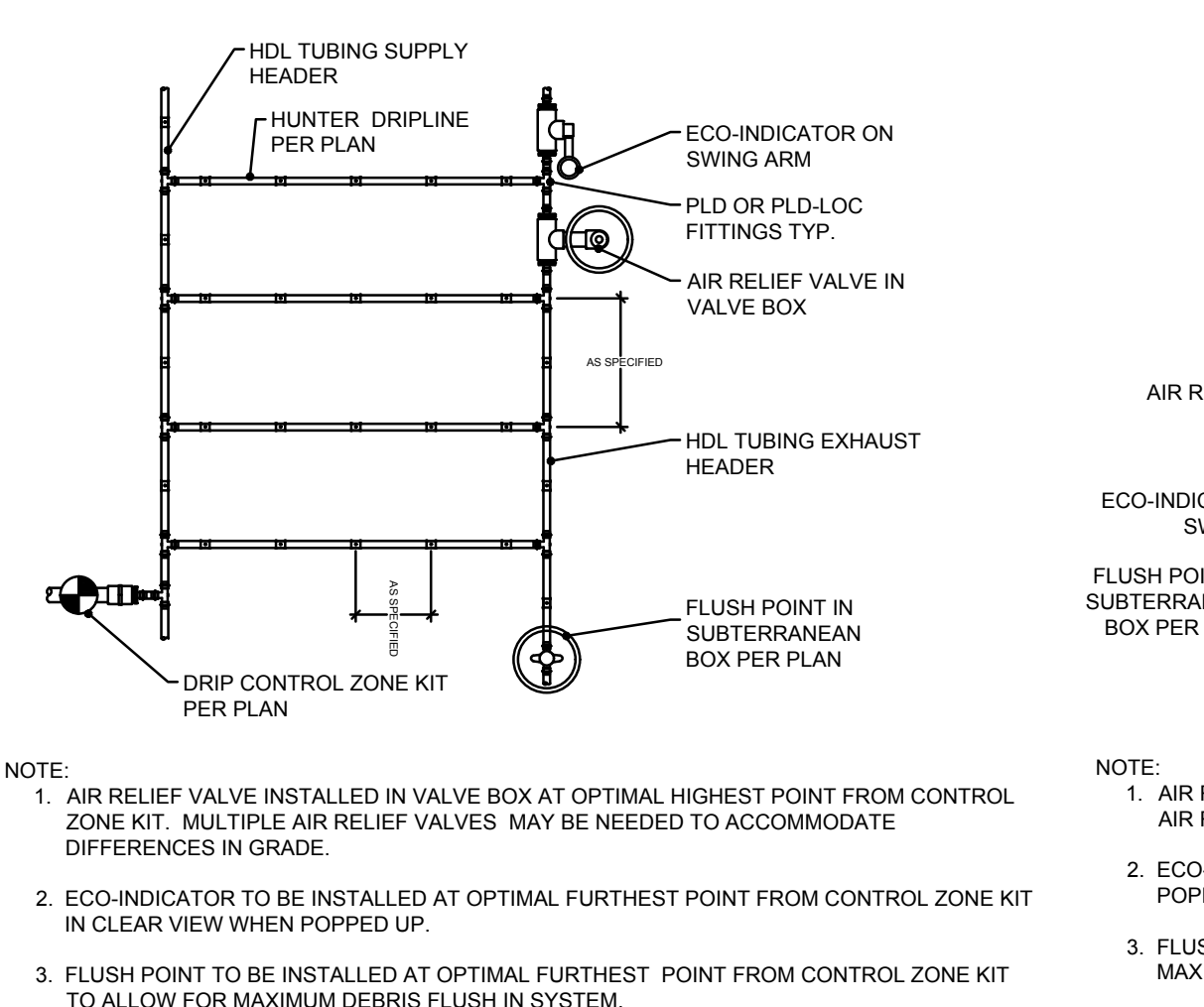

7 HUNTER DRIPLINE- PLANTING BED
N.T.S.

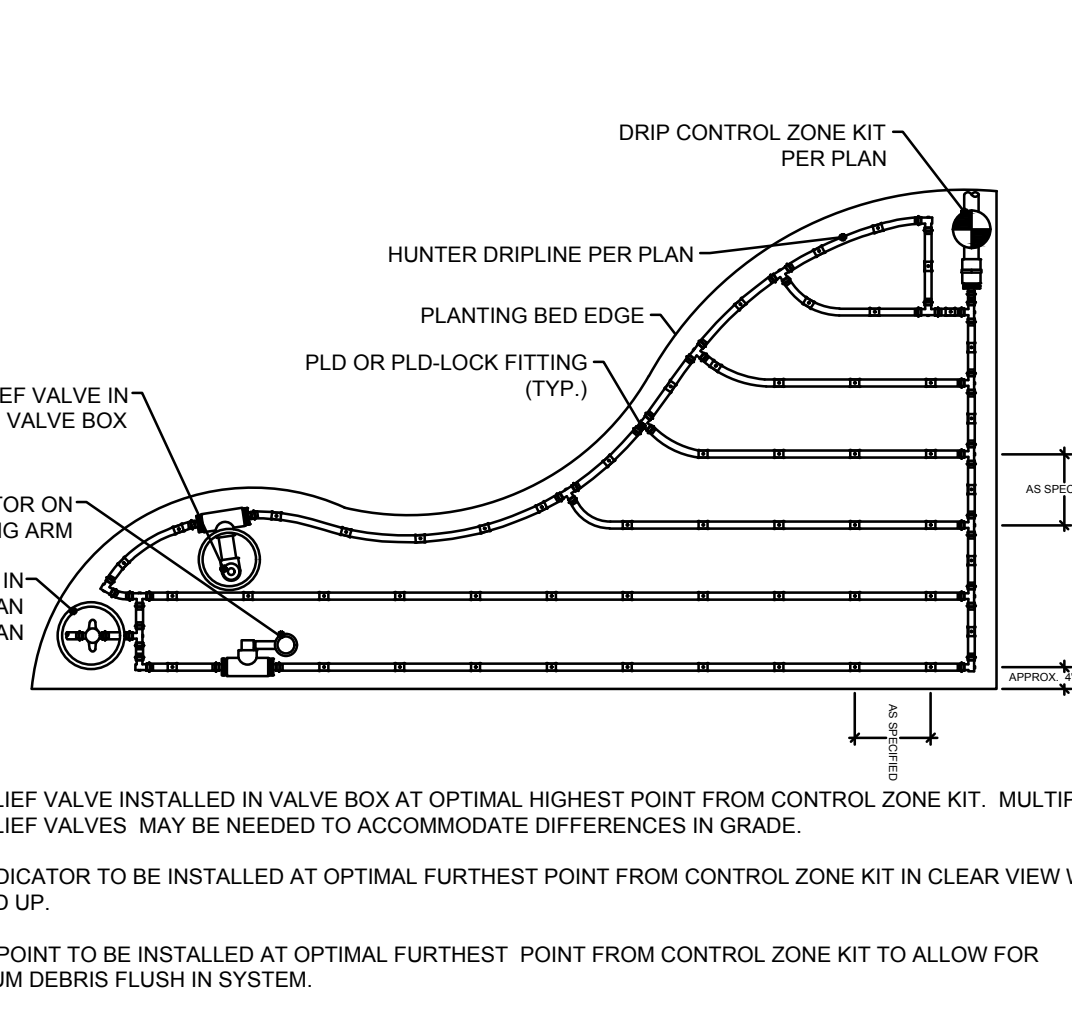

8 HUNTER DRIPLINE- IRREGULAR PLANTING AREA
N.T.S.

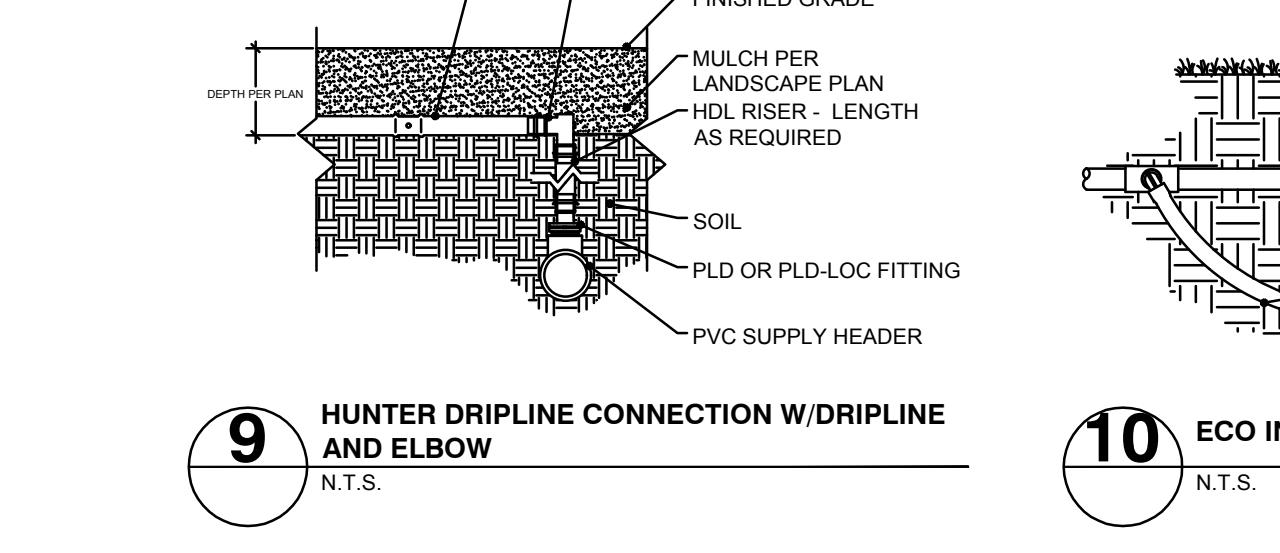

9 HUNTER DRIPLINE CONNECTION W/ DRIPLINE AND ELBOW
N.T.S.



10 ECO INDICATOR- FLEX TUBING
N.T.S.

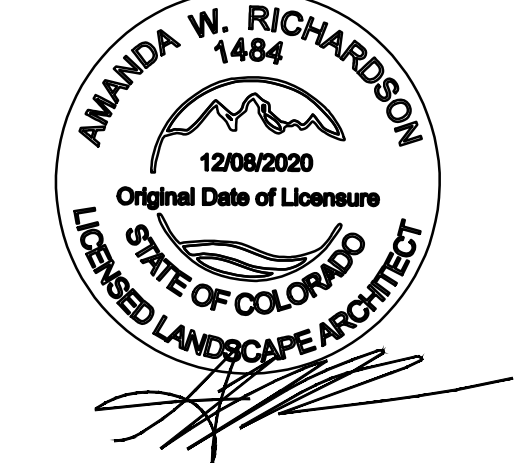

AWR Designs, LLC
P.O. Box 1746
Alledo, Texas 76008
amanda@awr-designs.com
c. 512.517.5589

CALL UTILITY NOTIFICATION CENTER OF COLORADO
1-800-922-1987
CALL 2-BUSINESS DAYS IN ADVANCE BEFORE YOU DIG, GRADE, OR EXCAVATE FOR THE MARKING OF UNDERGROUND MEMBER UTILITIES.

Know what's Below. Call before you dig.
THE LOCATIONS OF EXISTING UNDERGROUND UTILITIES ARE SHOWN IN AN APPROXIMATE WAY ONLY AND HAVE NOT BEEN INDEPENDENTLY VERIFIED BY THE OWNER OR ITS REPRESENTATIVE. THE CONTRACTOR SHALL DETERMINE THE EXACT LOCATION OF ALL EXISTING UTILITIES BEFORE COMMENCING WORK AND AGREE TO FULLY RESPONSIBILITY FOR ANY AND ALL DAMAGES WHICH MIGHT BE OCCURRED BY THE CONTRACTOR'S FAILURE TO EXACTLY LOCATE AND PRESERVE ANY AND ALL UNDERGROUND UTILITIES.

NOTICE: CONSTRUCTION SITE SAFETY IS THE SOLE RESPONSIBILITY OF THE CONTRACTOR. NEITHER THE OWNER NOR THE CONTRACTOR SHALL BE HELD RESPONSIBLE FOR ANY DAMAGE TO THE SAFETY OF THE WORK OR PERSONS ENGAGED IN THE WORK OF ANY MEMBER STRUCTURE, OR OF ANY OTHER PERSONS.

COPYRIGHT © 2025 ATWELL LLC. NO REPRODUCTION SHALL BE MADE WITHOUT THE PRIOR WRITTEN CONSENT OF ATWELL LLC.

24 HOUR EMERGENCY CONTACT

ATWELL
866.850.4200 www.atwell-group.com
9001 AIRPORT FREEWAY, SUITE 660
NORTH RICHLAND HILLS, TX 76180
972.956.9880

LOT 4A PARKER POINTE SUBD. FILING NO. 1. AMEND. NO. 1
S. PARKER RD & STROH RD
PARKER
DOUGLAS COUNTY, COLORADO

BLACK ROCK COFFEE BAR
13135 DECLAN DRIVE
PARKER
IRRIGATION SPECIFICATIONS AND DETAILS

DATE: 2025-8-21

REVISIONS

DRAWN BY: K. SARWAR
CHECKED BY: N. SALAZAR
PROJECT MANAGER: N. SALAZAR
JOB #: 24003198
FILE CODE: ##
SHEET NO. L2.02

ELECTRICAL SYMBOLS LEGEND	
SYMBOLS	DESCRIPTION
	FLUORESCENT FIXTURE, WITH FIXTURE DESIGNATED BY LETTER.
NL	NIGHT LIGHT – NOT SWITCHED
	CEILING OR WALL MOUNTED FIXTURE
	JUNCTION BOX
	SINGLE/DOUBLE FACED EXIT SIGN – NOT SWITCHED
	DOUBLE HEAD EMERGENCY LIGHT WITH BATTERY BACK UP.
S	SINGLE POLE SWITCH, +48" A.F.F.
S ₃	THREE WAY SWITCH, +48" A.F.F.
S _o	OUTLET CONTROL INDICATOR
S _D	DIMMER SWITCH
S _{OS}	OCCUPANCY SENSOR SWITCH
S _T	THERMAL OVERLOAD SWITCH
	DUPLEX RECEPTACLE, +18" A.F.F.
	DUPLEX RECEPTACLE ABOVE COUNTER, VERIFY HEIGHT
	FOURPLEX RECEPTACLE, +18" A.F.F.
	HALF SWITCHED DUPLEX RECEPTACLE
	POWER/PHONE/DATA FLUSH FLOOR OUTLET
	250 VOLT RECEPTACLE PER UNIT REQUIREMENTS
	600 VOLT RECEPTACLE PER UNIT REQUIREMENTS
	TELEPHONE/DATA SYSTEM OUTLET, 4" SQUARE BOX AND COVERPLATE, 3/4"C. TO CEILING SPACE UNLESS SHOWN WITH HOMERUN, +18" A.F.F.
	TELEVISION OUTLET PLASTER RING AT +18" A.F.F. (U.N.O.) HUBBELL COVERPLATE, 3/4"C. TO CEILING SPACE UNLESS SHOWN WITH HOMERUNS.
	CONDUIT BELOW FLOOR OR UNDERGROUND
	CONDUIT IN WALL OR ABOVE CEILING
LA 1,3	HOMERUN TO PANEL (SEE GROUNDING NOTE)
	MOTOR CONNECTION
	DISCONNECT SWITCH
	DUCT SMOKE DETECTOR
	LIGHTNING ARRESTER
*** ALL SYMBOLS ON LEGEND MAY NOT APPLY TO DRAWING(S). ***	

ABBREVIATIONS	
E	EXISTING LIGHT OR DEVICE TO REMAIN
ER	EXISTING LIGHT OR DEVICE TO BE REMOVED OR RELOCATED
R	RELOCATED LIGHT OR DEVICE
N	NEW LIGHT OR DEVICE
A.F.F.	ABOVE FINISHED FLOOR
C	CONDUIT
E.C.	EMPTY CONDUIT WITH PULLWIRE
E.D.F.	ELECTRICAL DRINKING FOUNTAIN.
GND	GROUND
MLO	MAIN LUGS ONLY
MCB	MAIN CIRCUIT BREAKER
S.E.S.	SERVICE ENTRANCE SECTION
WP	WEATHER PROOF
WR	WATER RESISTANT
GFI/GFCI	GROUND–FAULT CIRCUIT INTERRUPTER
U.N.O.	UNLESS NOTED OTHERWISE
	SECURITY CAMERA
	SPEAKER
S.U.S.E	SUITABLE FOR USE AS SERVICE EQUIPMENT

SCOPE OF WORK	
ELECTRICAL ENGINEERING CONSTRUCTION DOCUMENTATION FOR A 860 SF GROUND UP OF A NEW RETAIL SPACE FOR A NEW COFFEE SHOP.	
DESIGN INCLUDES:	
<ul style="list-style-type: none"> – ELECTRICAL SITE PLAN. – ELECTRICAL PHOTOMETRIC SITE PLAN. – IECC REPORT. – ONE–LINE DIAGRAM, PANEL SCHEDULES & FAULT CURRENT CALCULATIONS. 	
<ul style="list-style-type: none"> * REFER TO ARCHITECTURAL E2.0 FOR INTERIOR LIGHTING PLAN. * REFER TO ARCHITECTURAL E3.0 FOR INTERIOR POWER FLOOR & ROOF PLAN. 	

DEFERRED SUBMITTAL – FIRE ALARM NOTES	
<p>FIRE ALARM SYSTEM MODIFICATIONS MAY BE INCLUDED IN THIS PROJECT & SHALL BE A DEFERRED SUBMITTAL. ANY DEVICES SHOWN ON THE ELECTRICAL PLANS ARE FOR BID PURPOSES ONLY, AND NOT FOR CONSTRUCTION. ELECTRICAL CONTRACTOR SHALL VERIFY EXACT FIRE ALARM REQUIREMENTS, INCLUDING ANY MODIFICATIONS OR UPGRADES NECESSARY TO THE EXISTING SYSTEM, WITH LANDLORD AND AUTHORITY HAVING JURISDICTION. CONTRACTOR IS TO PROVIDE COMPLETE DWGS & ALL COSTS SHALL BE INCLUDED IN THE BID. FIRE ALARM DEVICES ARE TO BE COMPATIBLE WITH LANDLORDS FIRE ALARM SYSTEM. IF ENGINEERED FIRE ALARM DRAWINGS ARE REQUIRED, THEY ARE TO BE PREPARED BY A LOCAL, LICENSED FIRE ALARM CONTRACTOR AND SUBMITTED TO THE LANDLORD AND AUTHORITY HAVING JURISDICTION FOR APPROVAL PRIOR TO ANY WORK COMMENCEMENT.</p>	

GENERAL NOTES	
<p>A. EXAMINE THE CONTRACT DRAWINGS AND ALL AVAILABLE INFORMATION CONCERNING EXISTING INSTALLATION, STRUCTURE, AND LOCAL CONDITIONS. VISIT THE SITE TO UNDERSTAND THE NATURE AND SCOPE OF ALL WORK TO BE PERFORMED AND VERIFY EXISTING CONDITIONS. THE SUBMISSION OF A BID WILL BE TAKEN AS EVIDENCE THAT SUCH AN EXAMINATION HAS BEEN MADE AND THAT ALL EXISTING CONDITIONS HAVE BEEN CONSIDERED. NO ALLOWANCES WILL BE MADE AFTER THE PROJECT HAS BEEN AWARDED FOR FAILURE TO VERIFY EXISTING CONDITIONS. CONTRACTOR SHALL NOTIFY ENGINEER OF ANY DISCREPANCIES BETWEEN ACTUAL FIELD CONDITIONS AND THAT OF THESE DRAWINGS PRIOR TO BEGINNING CONSTRUCTION.</p>	
<p>B. THE CONTRACTOR SHALL BE HELD FULLY RESPONSIBLE FOR THE PROPER RESTORATION OF ALL EXISTING SURFACES REQUIRING PATCHING, PLASTERING, PAINTING AND /OR OTHER REPAIR DUE TO THE INSTALLATION OF ELECTRICAL WORK UNDER THE TERMS OF THE CONTRACT. CLOSE ALL OPENINGS, REPAIR ALL SURFACES, ETC., AS REQUIRED.</p>	
<p>C. SEE ARCHITECTURAL DRAWINGS FOR ALL DIMENSIONS, ELEVATIONS AND BUILDING DETAILS. VERIFY LOCATION OF ALL OUTLETS, SWITCHES, AND WALL MOUNTED LIGHTING FIXTURES WITH ARCHITECTURAL DRAWINGS AND ACTUAL CONDITIONS. SEE ARCHITECTURAL REFLECTED CEILING PLAN FOR EXACT LOCATION OF LIGHTING FIXTURES. VERIFY ALL CEILING TYPES WITH ARCHITECTURAL DRAWINGS BEFORE ORDERING FIXTURES.</p>	
<p>D. PRIOR TO ROUGH-IN AND FINAL CONNECTION, VERIFY ELECTRICAL CHARACTERISTICS AND EXACT LOCATION OF EQUIPMENT.</p>	
<p>E. GROUT AND SEAL ALL CONDUIT PENETRATIONS OF WALLS AND FLOOR SLABS TO PRESERVE FIRE RATING AND WATERTIGHT INTEGRITY.</p>	
<p>F. ALL WIRING TO BE INSTALLED IN RACEWAYS. TYPE OF RACEWAY SHALL BE AS REQUIRED BY CODE. MINIMUM CONDUIT SIZE SHALL BE 3/4"C. FOR POWER AND 1"C. FOR DATA. RACEWAYS RUN ACROSS ROOF SHALL BE MINIMUM 4" ABOVE ROOF.</p>	
<p>G. BRANCH CIRCUIT WIRING SHALL BE THHN/THWN INSULATION. EXTERIOR WIRING SHALL BE THWN–2. PANEL FEEDERS. SHALL BE TYPE XHHW. ALL WIRE SHALL BE COPPER. MINIMUM WIRE SIZE SHALL BE #12. PER THE LATEST NEC CODE ADOPTED BY THE CITY OF PARKER, A SEPARATE NEUTRALS ARE TO BE PROVIDED FOR EACH CIRCUIT OR PROVIDE MULTI–POLE HANDLE TIE FOR EACH MULTI–WIRE CIRCUIT</p>	
<p>H. PROVIDE CODE SIZED GROUNDING CONDUCTOR WIRE IN ALL CONDUITS.</p>	
<p>I. ALL ELECTRICAL EQUIPMENT SHALL BE NEW, U.L. APPROVED AND COMMERCIAL GRADE.</p>	
<p>J. ALL ELECTRICAL WORK SHALL BE INSTALLED IN ACCORDANCE WITH THE CITY OF PARKER, LATEST ADOPTED NATIONAL ELECTRICAL CODE (NEC), AND ALL APPLICABLE FEDERAL, STATE AND LOCAL CODES.</p>	
<p>K. IT SHALL BE THE ELECTRICAL CONTRACTOR'S RESPONSIBILITY TO PROVIDE ONE (1) SET OF COMPLETE CONSTRUCTION DRAWINGS.</p>	
<p>L. PROVIDE NEW PANEL DIRECTORIES INDICATING SPECIFIC CIRCUIT INFORMATION TO DISTINGUISH EACH CIRCUIT FROM ANY OTHER PER NEC.</p>	
<p>M. ELECTRICAL CONTRACTOR IS RESPONSIBLE FOR ALL DEMOLITION OF DEVICES, WIRE & CONDUIT. WHERE THESE ITEMS ARE NO LONGER USED ALL UNUSED WIRE SHALL BE REMOVED BACK TO THE PANEL. ANY DOWNSTREAM EQUIPMENT TO REMAIN IN USE SHALL BE RECONNECTED.</p>	

811
Know what's below.
Call before you dig.
 THE LOCATIONS OF EXISTING UNDERGROUND UTILITIES ARE SHOWN IN AN APPROXIMATE WAY ONLY AND HAVE NOT BEEN INDEPENDENTLY VERIFIED BY THE OWNER OR ITS REPRESENTATIVE. THE CONTRACTOR SHALL DETERMINE THE EXACT LOCATION OF ALL EXISTING UTILITIES BEFORE COMMENCING WORK, AND AGREES TO BE FULLY RESPONSIBLE FOR ANY AND ALL DAMAGE WHICH MAY OCCUR OCCASIONED BY THE CONTRACTOR'S FAILURE TO LOCATE AND PRESERVE ANY AND ALL UNDERGROUND UTILITIES.

NOTICE
 CONSTRUCTION SITE SAFETY IS THE SOLE RESPONSIBILITY OF THE CONTRACTOR. NEITHER THE OWNER NOR THE ENGINEER SHALL BE EXPECTED TO ASSUME ANY RESPONSIBILITY FOR SAFETY OF THE WORK, OF PERSONS ENGAGED IN THE WORK, OF ANY NEARBY STRUCTURES, OR OF ANY OTHER PERSONS.
 COPYRIGHT © 2022 ATWELL LLC. NO REPRODUCTION SHALL BE MADE WITHOUT THE PRIOR WRITTEN CONSENT OF ATWELL LLC.

ATWELL
 866.850.4200 www.atwell-group.com
 9001 AIRPORT FREEWAY, SUITE 660
 NORTH RICHLAND HILLS, TX 76180
 972.266.8860

LOT 4A, PARKER POINTE SUBD. FILING NO. 1, AMEND. NO. 1
 S. PARKER RD & STROH RD
 PARKER
 DOUGLAS COUNTY, COLORADO

BLACK ROCK COFFEE BAR
 13135 DECLAN DRIVE
 ELECTRICAL NOTES & SYMBOLS

DATE 2025-06-04

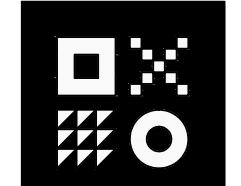

ARDEBILI
 Engineering
 Project Number: 25280 | Design Engineer: AV
 7328 E Stetson Dr., Scottsdale, AZ 85251
 P: 480.626.7072 | ardebilieng.com

DRAWN BY: AD
 CHECKED BY: PC
 PROJECT MANAGER: AV
 JOB #: 24003198
 FILE CODE: ##
 SHEET NO. **E0.1**

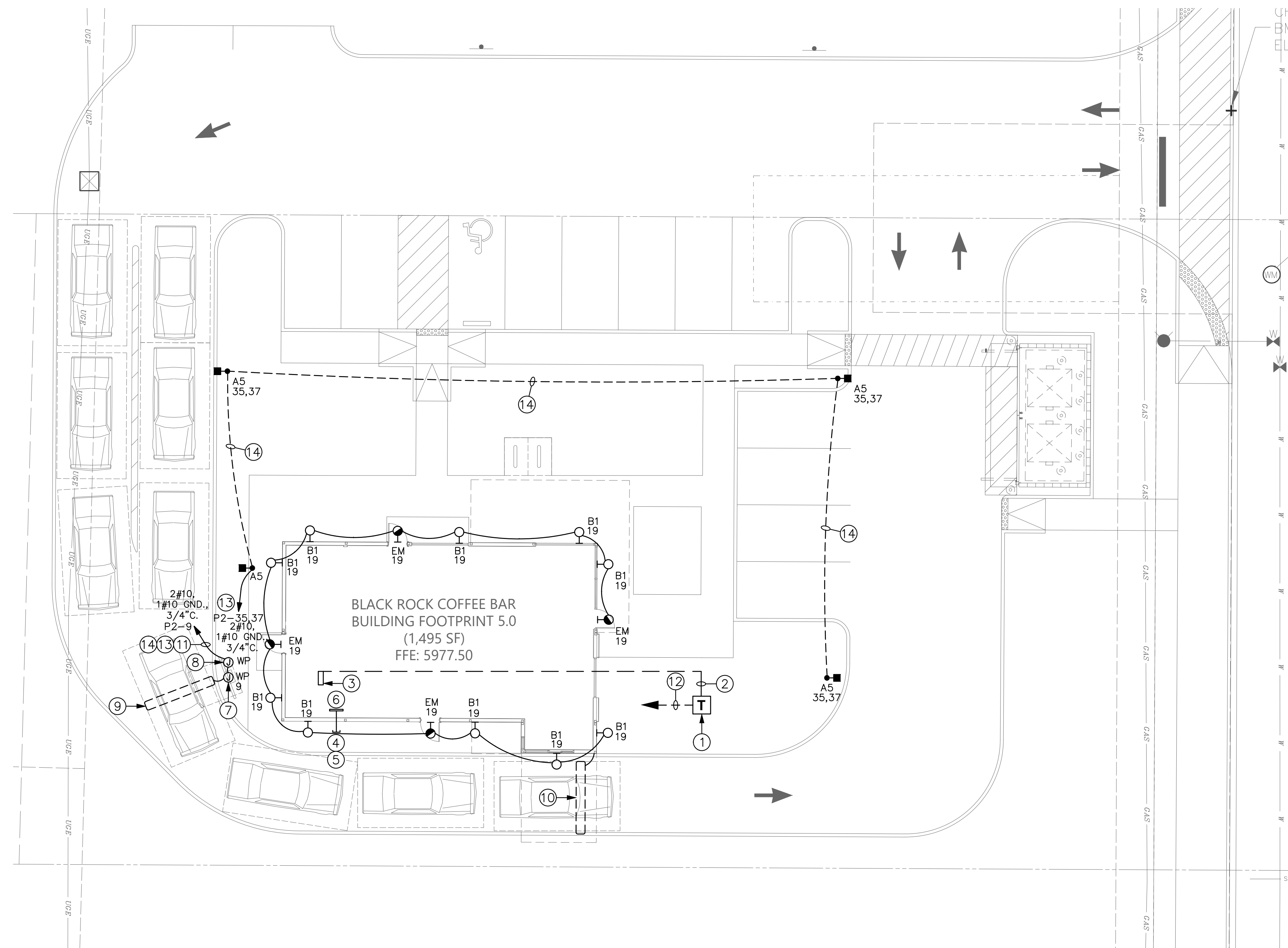

1 ELECTRICAL SITE PLAN
SCALE: 3/32"=1'-0"

GENERAL NOTES

- A. ALL EXTERIOR LIGHT FIXTURES TO COMPLY WITH LOCAL NIGHT SKY ORDINANCE.
- B. ALL EXTERIOR LIGHTING AND SIGNAGE TO BE FED WITH #10 CU. U.N.O.
- C. ALL EXTERIOR ELECTRICAL EQUIPMENT TO BE NEMA-3R RATED.
- D. CONTRACTOR TO COORDINATE EXACT SITE LIGHTING FIXTURE LOCATIONS WITH LANDSCAPE DRAWINGS.
- E. ALL FIXTURES INSTALLED OUTDOORS SHALL BE RATED FOR DAMP/WET LOCATIONS AS REQUIRED. THE CONTRACTOR SHALL COORDINATE DAMP/WET LOCATION RATING PER NEC ARTICLE 410-4. ALL INSTALLATIONS SHALL CONFORM TO NEC ARTICLE 410, ALL SUB ARTICLES.
- F. FIRE ALARM EQUIPMENT SHALL BE COORDINATED FOR EXACT LOCATION AND REQUIREMENTS WITH FIRE MARSHALL.
- G. ALL PVC CONDUIT MUST HAVE A MINIMUM OF #12 CU. GROUND CONDUCTOR.
- H. CONTRACTOR SHALL BE RESPONSIBLE FOR COORDINATION AND SCHEDULING WITH POWER AND TELEPHONE UTILITY COMPANIES INCLUDING PROVIDING (2) COMPLETE SETS OF DRAWINGS TO EACH COMPANY. ALL WORK SHALL BE INSTALLED PER EACH UTILITY COMPANIES FINAL DESIGN DRAWINGS.
- I. ELECTRICAL CONTRACTOR SHALL COORDINATE EXACT LOCATIONS AND MOUNTING HEIGHTS OF ALL EXTERIOR LIGHT FIXTURES WITH ARCHITECTURAL DRAWINGS.

KEYED NOTES

- 1. PROPOSED LOCATION OF NEW UTILITY TRANSFORMER. VERIFY EXACT LOCATION WITH UTILITY COMPANY.
- 2. NEW SECONDARY FEEDERS FROM TRANSFORMER PER POWER COMPANY REQUIREMENTS. ROUTING SHOWN FOR REFERENCE ONLY.
- 3. PROPOSED LOCATION OF NEW SERVICE ENTRANCE SECTION IN NEMA-1 ENCLOSURE.
- 4. 4" UNDERGROUND PVC CONDUIT WITH PULLWIRE AND BENDS PER TELEPHONE COMPANY REQUIREMENTS. TRENCH AND BACKFILL AS REQUIRED. REFER TO NEC TABLE 300.5 FOR ADDITIONAL REQUIREMENTS.
- 5. TERMINATE AND STUB CONDUIT TO PROPERTY LINE OR EXISTING CABINET PER TELEPHONE COMPANY REQUIREMENTS.
- 6. PROPOSED LOCATION OF MPOP (MAIN POINT OF PRESENCE) FOR TELEPHONE COMPANY DEMARCATION AND TERMINATION.
- 7. PROVIDE W.P. J-BOX FOR DRIVE-THRU MENU BOARD. COORDINATE EXACT POWER REQUIREMENTS WITH MANUFACTURER PRIOR TO INSTALLATION.
- 8. PROVIDE W.P. J-BOX FOR DRIVE-THRU SPEAKER. COORDINATE EXACT POWER REQUIREMENTS WITH MANUFACTURER PRIOR TO INSTALLATION.
- 9. CONNECT SPEAKER PEDESTAL TO DETECTION LOOP. COORDINATE EXACT REQUIREMENT WITH MANUFACTURER PRIOR TO ROUGH-IN.
- 10. PROVIDE STUB UP FOR DETECTION LOOP. COORDINATE EXACT REQUIREMENT WITH MANUFACTURER PRIOR TO ROUGH-IN.
- 11. PROVIDE (3) ELECTRICAL CONDUITS FOR DRIVE-THRU EQUIPMENT.
- 12. PROPOSED PRIMARY PER UTILITY COMPANY.
- 13. CIRCUIT ROUTED THRU TIME CLOCK.
- 14. PROVIDE #10 WIRE IN 3/4" NONMETALLIC CONDUIT, 24" BELOW FINISHED GRADE OR PER NEC 300.5. VERIFY EXACT ROUTING PRIOR TO INSTALLATION. TRENCH, BACKFILL, AND REPAIR LANDSCAPE/HARDSCAPE AS REQUIRED.

CONDUIT ROUTING NOTE

CONDUIT ROUTING IS SHOWN FOR REFERENCE ONLY. CONTRACTOR SHALL FIELD COORDINATE EXACT CONDUIT ROUTING WITH ARCHITECT PRIOR TO INSTALLATION. ROUTE FEEDERS CONCEALED BELOW GRADE ONSITE AND CONCEALED FROM PUBLIC VIEW WITHIN SPACE WHEN POSSIBLE.

NOTE

ALL UNDERGROUND CONDUIT FOR BRANCH CIRCUITS SHALL BE A MINIMUM OF 24" BELOW GRADE, OR PER NEC TABLE 300.5.



Know what's Below. Call before you dig.
THE LOCATIONS OF EXISTING UNDERGROUND UTILITIES ARE SHOWN IN AN APPROXIMATE WAY ONLY AND HAVE NOT BEEN INDEPENDENTLY VERIFIED BY THE OWNER OR ITS REPRESENTATIVE. THE CONTRACTOR SHALL DETERMINE THE EXACT LOCATION OF ALL EXISTING UTILITIES BEFORE COMMENCING WORK AND AGREES TO BE FULLY RESPONSIBLE FOR ANY AND ALL DAMAGE WHICH MIGHT BE OCCASIONED BY THE CONTRACTOR'S FAILURE TO LOCATE AND PRESERVE ANY AND ALL UNDERGROUND UTILITIES.

NOTICE
CONSTRUCTION SITE SAFETY IS THE SOLE RESPONSIBILITY OF THE CONTRACTOR. NEITHER THE OWNER NOR THE ENGINEER SHALL BE DEEMED TO ASSUME ANY RESPONSIBILITY FOR SAFETY OF THE WORK OF PERSONS ENGAGED IN THE WORK OF ANY NEARBY STRUCTURES, OR OF ANY OTHER PERSONS.
COPYRIGHT © 2022 ATWELL LLC. NO REPRODUCTION SHALL BE MADE WITHOUT THE PRIOR WRITTEN CONSENT OF ATWELL LLC.



LOT 4A, PARKER POINT SUBD. FILING NO. 1, AMEND. NO. 1
S. PARKER RD & STROH RD
PARKER
DOUGLAS COUNTY, COLORADO

BLACK ROCK COFFEE BAR
13135 DECLAN DRIVE
ELECTRICAL SITE PLAN

DATE 2025-06-04

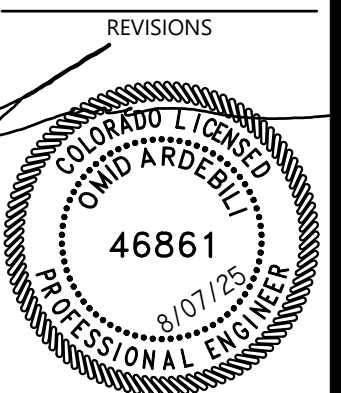

DRAWN BY: AD
CHECKED BY: PC
PROJECT MANAGER: AV
JOB #: 24003198
FILE CODE: ##
SHEET NO. E1.0

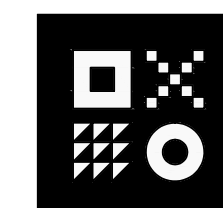

ARDEBILI Engineering
Project Number: 25280 | Design Engineer: AV
7328 E Stetson Dr., Scottsdale, AZ 85251
P: 480.626.7072 | ardebilieng.com

811
Know what's Below.
Call before you dig.
 THE LOCATIONS OF EXISTING UNDERGROUND UTILITIES ARE SHOWN IN AN APPROXIMATE WAY ONLY AND HAVE NOT BEEN REPRESENTATIVELY VERIFIED BY THE CONTRACTOR OR ITS REPRESENTATIVE. THE CONTRACTOR SHALL DETERMINE THE EXACT LOCATION OF ALL EXISTING UTILITIES BEFORE COMMENCING WORK AND AGREE TO BE FULLY RESPONSIBLE FOR ANY AND ALL DAMAGES WHICH MAY BE OCCASIONED BY THE CONTRACTOR'S FAILURE TO LOCATE AND PRESERVE ANY AND ALL UNDERGROUND UTILITIES.

NOTICE
 CONSTRUCTION SITE SAFETY IS THE SOLE RESPONSIBILITY OF THE CONTRACTOR. NEITHER THE OWNER NOR THE ENGINEER SHALL BE DEEMED TO ASSUME ANY RESPONSIBILITY FOR SAFETY OF THE WORK OR PERSONS ENGAGED IN THE WORK OF ANY NEARBY STRUCTURES, OR OF ANY OTHER PERSONS.

COPYRIGHT © 2025 ATWELL LLC. NO REPRODUCTION SHALL BE MADE WITHOUT THE PRIOR WRITTEN CONSENT OF ATWELL LLC.

ATWELL
 866.850.4200 www.atwell-group.com
 9001 AIRPORT FREEWAY, SUITE 660
 NORTH RICHLAND HILLS, TX 76180
 972.636.8860

LOT 4A, PARKER POINT SUBD. FILING NO. 1, AMEND. NO. 1
 S. PARKER RD & STROH RD
 PARKER
 DOUGLAS COUNTY, COLORADO

BLACK ROCK COFFEE BAR
 13135 DECLAN DRIVE
 PHOTOMETRIC SITEPLAN

DATE 2025-06-04

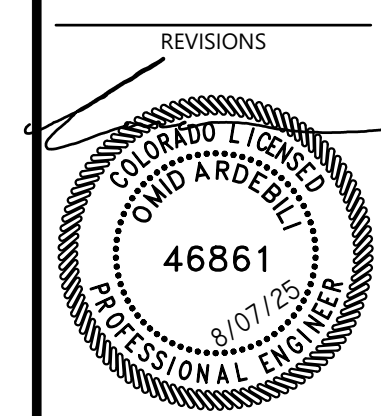

DRAWN BY: AD
 CHECKED BY: PC
 PROJECT MANAGER: AV
 JOB #: 24003198
 FILE CODE: ##
 SHEET NO. E.1.1

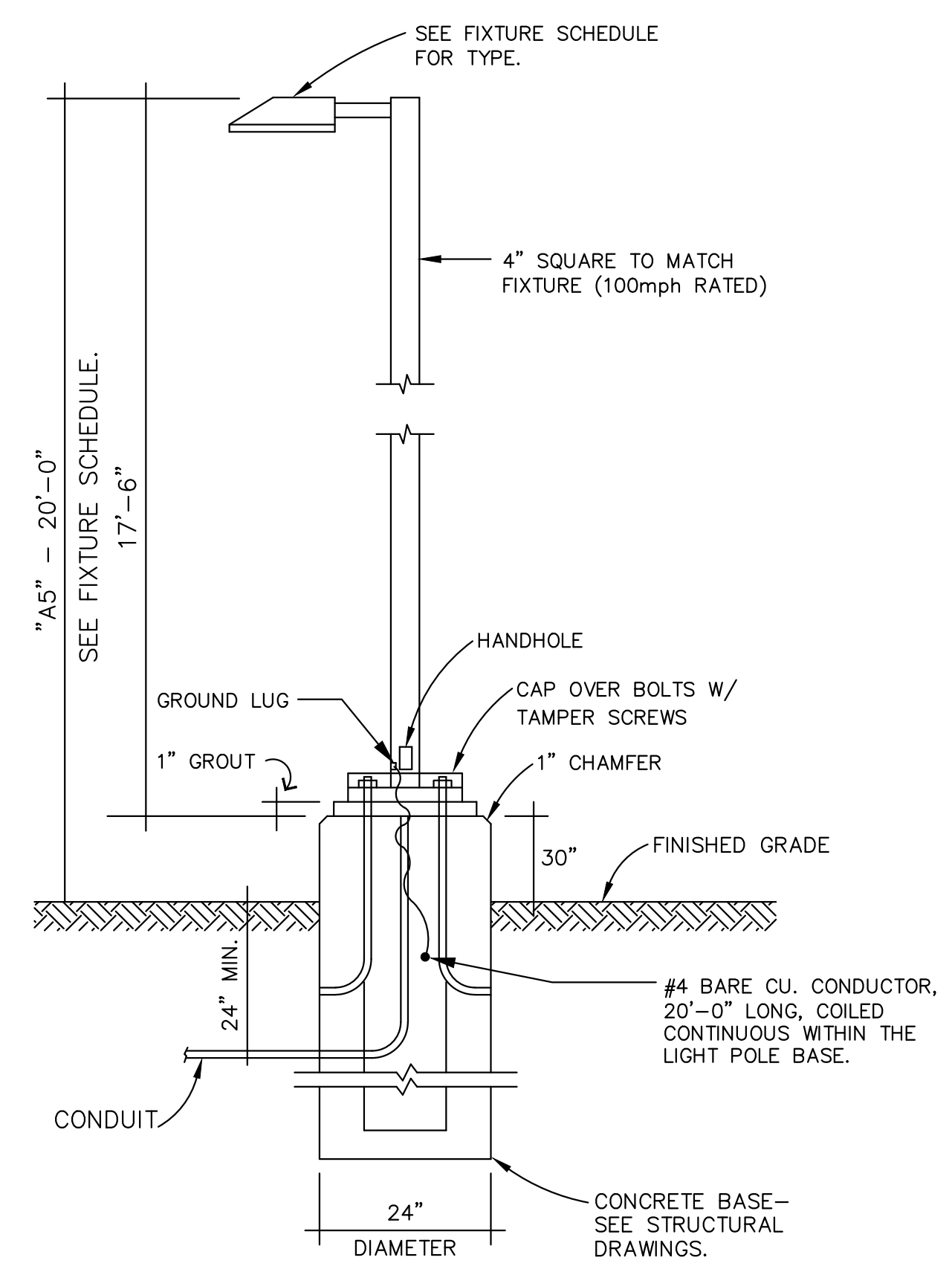

LIGHT POLE 'A5'

N.T.S.
 NOTE: CONTRACTOR SHALL PROVIDE NEW POLE BASES WHERE INDICATED ON PLANS. LIGHTING FIXTURE POLE DETAILS AND DESCRIPTIONS ARE FOR ELECTRICAL REFERENCES ONLY. THE POLE AND BASE SHALL BE DESIGNED BY A STRUCTURAL ENGINEER REGISTERED IN THE STATE OF COLORADO AND BE STAMPED AND SEALED ACCORDINGLY.

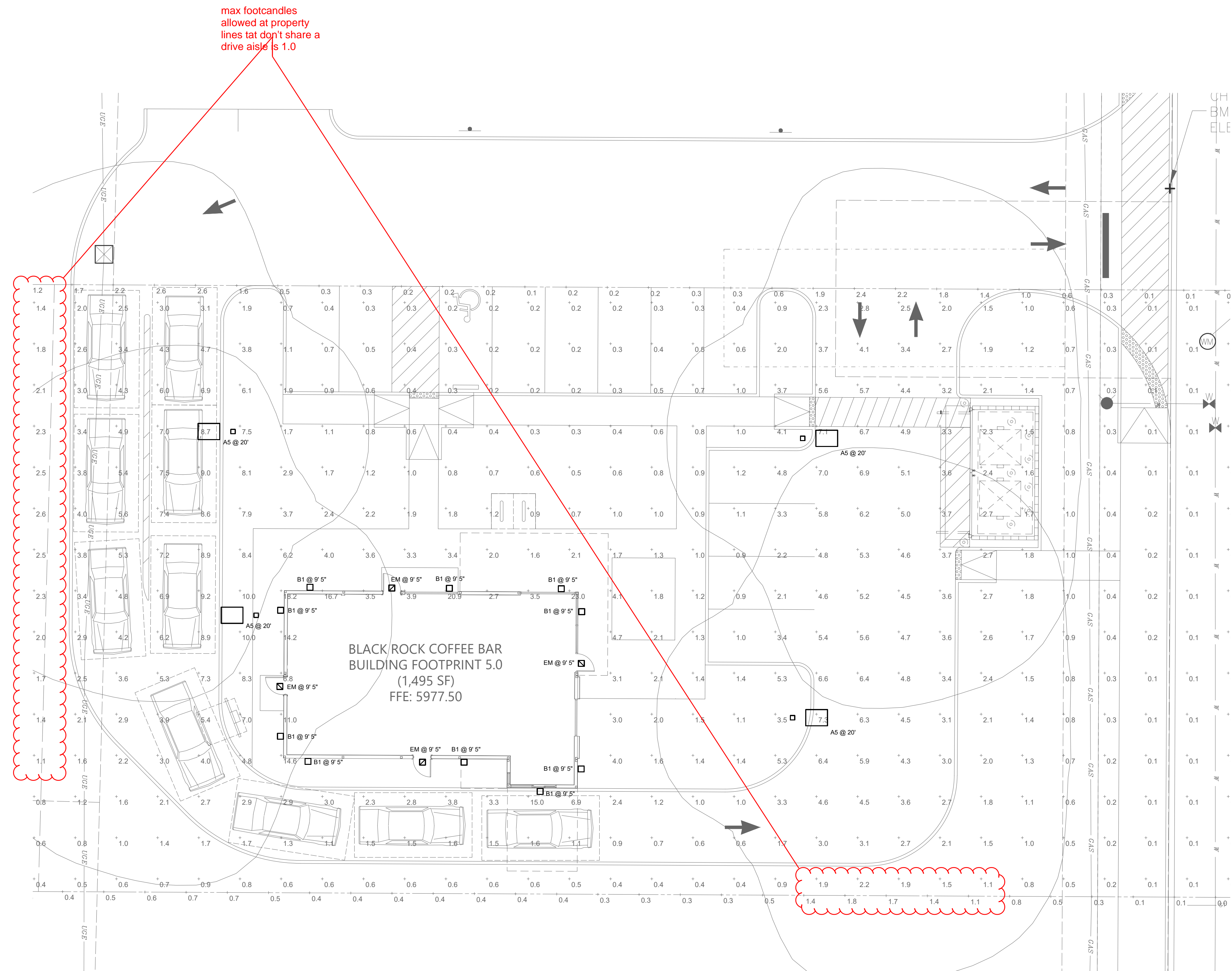

max footcandles allowed at property lines that don't share a drive aisle is 1.0

is this accurate? max of 23.0 not shown on photometric plan

Lighting of parking lots and drive aisles shall have a uniformity ratio of six to one (6:1) (maximum to minimum), need to show ratios for parking lot and drive aisles.

1 ELECTRICAL PHOTOMETRIC SITE PLAN
 SCALE: 3/32"=1'-0"

Statistics						
Description	Symbol	Avg	Max	Min	Max/Min	Avg/Min
SITE FC	+	2.4 fc	23.0 fc	0.0 fc	N/A	N/A
FC@ PROPERTY LINE	+	0.5 fc	2.6 fc	0.0 fc	N/A	N/A

need to indicate colors of fixtures and height of freestanding poles

Schedule										
Symbol	Label	Quantity	Manufacturer	Catalog Number	Description	Lamp	Lumens Per Lamp	Lumen Multiplier	Light Loss Factor	Wattage
□	B1	10	RB LIGHTING	4427-XX-13W-3K	4" LED SQUARE CYLINDER DOWNLIGHT, OUTDOOR WALL MOUNTED LED, WET RATED FIXTURE	LED CYLINDER	911	1	1	13.3
▣	EM	4	LITHONIA LIGHTING	WDGE2 LED P2 30K 80CRI T3M MVOLT SRM E20WC (FINISH) (OR EQUAL)	WALL PACK LED WITH P2 - PERFORMANCE PACKAGE, 3000K, 80CRI, TYPE 3 MEDIUM OPTIC. FIXTURE IS EQUIPPED WITH 90 MINUTS EMERGENCY BATTERY PACK.	LED	1964	1	1	189815
□	A5	4	OPTEC LED	OLA1-080-40-5	SINGLE HEAD LED POLE LIGHT, LED AREA SERIES LARGE 80W, 4000K, TYPE 5 MOUNTED AT 15 AFG	LED POLE	12719	1	0.91	80

Optec LED LIGHTING
Area Series (Small)

The OL1 Small Series is a stylish aerodynamic area luminaire that fits within today's accepted design form factors. Excellent optical performance is achieved with Nichia brand LEDs and engineered discrete optics. LED life is assured through efficient thermal coupling and dissipation via a durable, pressure die cast, low-copper alloy, aluminum housing. Engineered to last, all gaskets are anti-UV, anti-gassing with no harmful out-gassing. All models come standard with a universal pole-mount bracket or an optional wall surface box. Luminaires are available with a number of options including alternate CCT choices, finishes, photocells and sensors.

FEATURES

- LED Brand: Nichia
- Color Temperatures: 4000K & 5000K (Other CCT's are available upon request)
- CRI: 70
- Lumen Maintenance: L70 = 50,000 hours
- Full Cutoff (meets DA criteria)
- Operating Temperature: -40°C (-40°F) to 40°C (104°F)
- Durable All Aluminum Pressure Die Cast Housing
- Powder Coat Finish
- Salt Fog Tested to 2500 hours / per ASTM B117
- IP65 Rated (over listed) / NEMA IEC 60529
- Mounting: Universal Round or Square Pole, Wall Surface Box

ELECTRICAL SPECIFICATIONS

- Power Input: 120-277V (347-480V Optional)
- Power Factor: > 0.95
- THD: < 15%
- Surge Protection: 20 kV
- Control Options: 0-10V Dimming standard (Photocell and Occupancy Sensors Optional)

TESTS & CERTIFICATIONS

- ETL (UL 1598, UL 8750, NEMA C82.77)
- CSA (C22.2 No.250.0)
- RoHS Compliant
- Design Lights Consortium (Premium)
- 3G Vibration tested (ANSI C136.31)



WARRANTY
• Up to 10-Year Warranty (parts or replacement)

Optec LED Lighting, 1700 De Soto Place, Ontario, CA 91761

PERFORMANCE SPECIFICATIONS

Distribution	Model / Wattage	Lumens		E		U		Bug Rating
		2000K	5000K	E	U	E	U	
Type 2	OL-A1-080	10,801	10,800	3 *	0	0	1	
	OL-A1-120	15,840	16,200	3 *	0	0	2	
	OL-A1-150	19,800	20,250	3 *	0	0	2	
Type 3	OL-A1-080	11,600	11,760	2 *	0	0	2	
	OL-A1-120	16,561	16,820	3 *	0	0	2	
	OL-A1-150	20,542	21,000	3 *	0	0	2	
Type 3L	OL-A1-080	10,799	10,960	3 *	0	0	3	
	OL-A1-120	15,960	16,199	3 *	0	0	3	
	OL-A1-150	19,800	20,250	4 *	0	0	3	
Type 3R	OL-A1-080	10,799	10,960	3 *	0	0	3	
	OL-A1-120	15,960	16,198	3 *	0	0	3	
	OL-A1-150	19,800	20,250	4 *	0	0	3	
Type 4	OL-A1-080	10,798	10,784	2 *	0	0	2	
	OL-A1-120	15,472	15,712	2 *	0	0	2	
	OL-A1-150	19,046	19,349	3 *	0	0	2	
Type 4L	OL-A1-080	10,800	10,960	3 *	0	0	3	
	OL-A1-120	16,020	16,280	3 *	0	0	3	
	OL-A1-150	19,800	20,250	4 *	0	0	4	
Type 4R	OL-A1-080	10,800	10,960	3 *	0	0	3	
	OL-A1-120	16,000	16,320	3 *	0	0	3	
	OL-A1-150	19,781	20,250	4 *	0	0	4	
Type 5	OL-A1-080	10,032	10,185	4 *	0	0	3	
	OL-A1-120	15,049	15,278	4 *	0	0	3	
	OL-A1-150	18,811	19,097	5 *	0	0	4	

* Backlight = 1 when BC (Backlight Control System) is applied.

Voltage (V)	CCT (K)		
	80W	120W	150W
120	0.67	1.00	1.25
208	0.38	0.58	0.72
240	0.33	0.50	0.63
277	0.29	0.43	0.54
347	0.23	0.35	0.43
480	0.17	0.25	0.31

Optec LED LIGHTING 1700 De Soto Place, Ontario, CA 91761 P: 888-743-5220 optecledlighting.com

Optec LED LIGHTING
Area Series (Small)

ORDERING INFORMATION

EXAMPLE: OL-A1-120-UNVL-50-4-SQ-BZ-PR-TL12

SERIES	WATTAGE	VOLTAGE	COLOR TEMP	DISTRIBUTION	MOUNTING	FINISH	CONTROLS / OPTIONS
OL-A1 = Optec LED Area Light	080 = 80W 120 = 120W 150 = 150W	UNVL = 120-277V UNWH = 130-480V	30 = 3000K 40 = 4000K 50 = 5000K	2 = Type 2 3 = Type 3 3L = Type 3 Left 3R = Type 3 Right 4 = Type 4 4L = Type 4 Left 4R = Type 4 Right 5 = Type 5	SQ = Square Pole RD = Round Pole WM = Wall Mount TR = Trench Adapter LK = Levelling Kit 5 = Type 5	WH = White BK = Black BA = Brushed Aluminum GM = Graphite Metallic CF = Custom Finish	DS95 = Occupancy Sensor (Wattage/Type) PR = Photocell (10V, 5' min) PS = Photocell Receptacle 5-pin RF = Photocell Receptacle 7-pin WCS = Wireless Control (Dimming) SF = Single Rate (120V, 277V, 347V) BC = Backlight (CCT, 240V, 480V) TL12 = Twist Lock (Shoring Cap 504 = 100000 cycles) TL24 = Twist Lock (Proceal 120V) TL28 = Twist Lock (Proceal 240V) TL27 = Twist Lock (Proceal 277V) TL26 = Twist Lock (Proceal 280V) TL34 = Twist Lock (Proceal 347V) TL40 = Twist Lock (Proceal 480V)

1. For details, reference accessory data sheet.
2. WM option requires 5/8" pole mount bracket (ordering example: SQ WM).
3. Levelling kit adjusts up to 5 degrees or down to 5 degrees.
4. DS95 - For photocell information and options contact factory.
5. WCS - For wireless controls information and options contact factory for details.
6. Photocell (option) = 5' in "20" model (unless otherwise specified).

PHOTOMETRIC PERFORMANCE

Isocandela plots - OL-A1 120W model in 5000K CCT @ 30' mounting height. Distances are in units of mounting height.

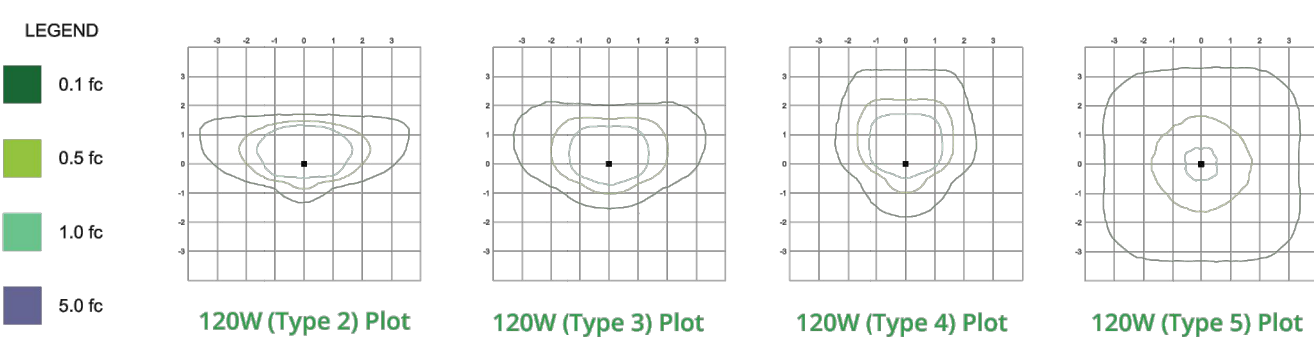

Published luminaire photometric testing performed to IESNA-79-08 standards

DIMENSIONS, WEIGHTS & EPA

Wattage	Length (inches / mm)			Width (inches / mm)			Height (inches / mm)			Weight (lbs. / kg)
	80W	120W	150W	80W	120W	150W	80W	120W	150W	
80	0.96	1.92	1.81	2.77	3.63					
120	0.96	1.92	1.81	2.77	3.63					
150	0.96	1.92	1.81	2.77	3.63					

Optec LED LIGHTING 13040 West Lisbon Road, Unit 400, Brookfield, WI 53005 P: 888-743-5220 optecledlighting.com

4427
120V

4" LED Architectural Square Cylinder Downlight

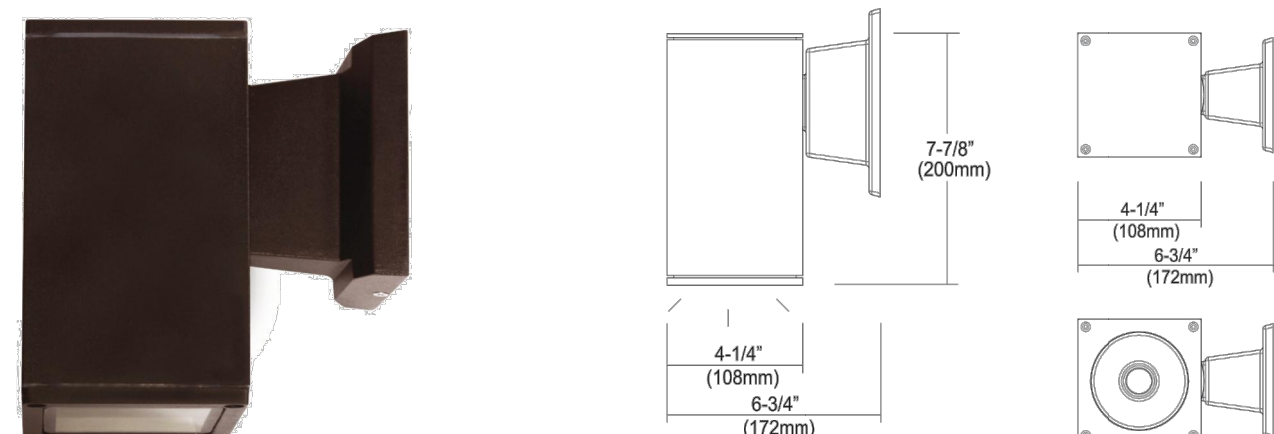

DESCRIPTION

The Outdoor LED Cylinder Family features wet location rated wall mount style cylinders with down light and up & down light options. Choose from energy efficient 13W, 17W, or 27W AC modules, with finishes available in black, brushed nickel, or oil-rubbed bronze. Features Triac dimming down to 5%, using most standard dimmers. Utilizes AC circuit on board technology for cooler operating temperature and extended lifetime.

DESIGN FEATURES

- Construction**
 - Aluminum die-cast with powder coat finish
- Electrical**
 - 120V Direct AC operation with DOB
 - Triac dimming down to 5%
 - Various wattages of modules available
 - Cooler operating temperature without driver
 - Operating temperature: -31°F (-35°C) to 122°F (50°C)
 - Stable driving current prevents inrush damage to circuit switches and modules
 - Available in 80CRI, 3000K & 4000K
- Installation**
 - Easy surface mounting for simple installation using anchors and screws
 - J-box mountable
- Lens**
 - Clear acrylic lens protects LEDs while allowing for optimum lumen output
 - 37° beam angle
- Finish**
 - Black, brushed aluminum or oil-rubbed bronze
- Certifications**
 - cCSAus for wet location
 - 5 year limited warranty
 - Wet location rated

TEL: 800.937.6925 | Fax: 800.207.9509 | www.rplighting.com

4427
120V

Specification & Ordering

Model #	Dimensions (H x W x D)	Watt				Lumens (delivered)				Lumens (source)				Color Temp			
		13W	17W	27W	1755lm	845lm	1105lm	1710lm	3K 3000K	4K 4000K							
4427	7-7/8" x 4-1/4" x 6-3/4"																

Model #	Finish	Watts	CCT
4427	BK : Black BA : Brushed Aluminum OB : Oil-rubbed Bronze	-13 : 13W -17 : 17W -27 : 27W	-3K : 3000 K -4K : 4000 K

TEL: 800.937.6925 | Fax: 800.207.9509 | www.rplighting.com

WDGE2 LED
Architectural Wall Sconce
Precision Refractive Optic



Specifications

- Depth (D1): 7"
- Depth (D2): 1.5"
- Height: 9"
- Width: 11.5"
- Weight: 13.5 lbs (without options)

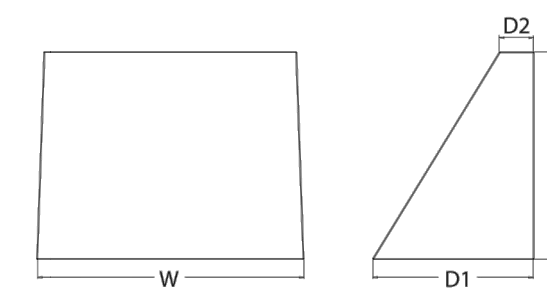

Items marked by a shaded background qualify for the Design Select program and ship in 15 days or less. To learn more about Design Select, visit www.acuitybrands.com/designselect. See ordering tree for details.

WDGE LED Family Overview

Luminaire	Optics	Standard Eff. @C	Cold Eff. @-20°C	Sensor	Approximate Lumens (HOSEA, 90CRI)							
					P0	P1	P2	P3	P4	P5	P6	
WDGE1 LED	Visual Comfort	4W			750	1,200	2,000					
WDGE2 LED	Visual Comfort	10W	18W	Standalone / r/light	1,200	2,000	3,000	4,500	6,000			
WDGE2 LED	Precision Refractive	10W	18W	Standalone / r/light	700	1,200	2,000	3,200	4,200			
WDGE3 LED	Precision Refractive	15W	18W	Standalone / r/light	7,500	8,500	10,000	12,000				
WDGE4 LED	Precision Refractive			Standalone / r/light	12,000	16,000	18,000	20,000	22,000	25,000		

Ordering Information

EXAMPLE: WDGE2 LED P3 40K 80CRI T3M MVOLT 5RM DDBXD

Series	Package	Color Temperatures	CRI	Distribution	Mounting	Shipped included	Shipped separately
WDGE2 LED	P0*	27K 2700K	40K 4000K	70CRI*	T1S Type I Short	MVOLT	AW5 Surface mounting bracket
	P1†	30K 3000K	50K 5000K	80CRI*	T2M Type II Medium	347*	AW5 Surface mounting bracket
	P2‡	35K 3500K	AMSP Amber	LW Limited Wavelength	T3M Type III Medium	480*	ICW Indirect Canopy/ Ceiling Washer Bracket†
	P3§				T4M Type IV Medium		AW5 Surface mounting bracket
	P4¶				T5TM Forward Thru Medium		AW5 Surface mounting bracket

Options	Finish
E1WH Emergency battery backup, Certified in CA Title 20 (MERS) (10V, 5' min)	DDBD Dark bronze
E2WK Emergency battery backup, Certified in CA Title 20 (MERS) (10V, 5' min)	DBLD Black
DMG 0-10V dimming wires pulled outside fixture (for use with an external controller, ordered separately)	DNAX Natural aluminum
ACE Bottom conduit entry for back box (P88K)	DWKO White
CCE Coastal Construction†	DSDD Sandstone
	DOBTD Textured dark bronze
	DNATD Textured natural aluminum
	DWWD Textured white
	DSSTD Textured sandstone

LITHONIA LIGHTING COMMERCIAL OUTDOOR 1 Acuity Way • Decatur, GA 30035 • Phone: 1-800-705-SERV (7378) • www.lithonia.com
© 2019-2025 Acuity Brands Lighting, Inc. All rights reserved.

Accessories

- WDGE5 DSDBU WDGE5 8-inch Architectural Wall Sconce (Specify finish)
- WDGE2 P88K DBBDU WDGE2 surface-mounted back box (Specify finish)
- WDGE2 P88K DBBDU WDGE2 surface-mounted back box (Specify finish)

Performance Data

Lumen values are from photometric tests performed in accordance with IESNA LM-79-08. Data is considered to be representative of the configurations shown, within the tolerances allowed by lighting facts. Contact factory for performance data on any configuration not shown here.

Performance Package	System Watt	Dist. Type	27K (2700K, 70 CRI)				30K (3000K, 70 CRI)				40K (4000K, 80 CRI)				50K (5000K, 80 CRI)				And/or (Limited Wavelength)					
			Lumens	U	E	U	Lumens	U	E	U	Lumens	U	E	U	Lumens	U	E	U						
P0	7W	T1S	636	92	0	0	666	92	0	0	699	103	0	0	691	100	0	0	712	47	0	0	1	
			T2M	642	96	0	0	691	101	0	0	728	106	0	0	719	104	0	0	741	46	0	0	0
			T3M	648	94	0	0	679	98	0	0	712	103	0	0	704	102	0	0	726	47	0	0	0
			T4M	653	95	0	0	683	99	0	0	713	104	0	0	708	103	0	0	730	46	0	0	1
P1	11W	T2M	1,130	163	0	0	1,204	168	0	0	1,264	173	0	0	1,260	172	0	0	1,260	172	0	0	1	
			T3M	1,130	163	0	0	1,265	188	0	0	1,265	173	0	0	1,260	172	0	0	1,260	172	0	0	1
			T4M	1,130	163	0	0	1,179	166	0	0	1,228	171	0	0	1,223	170	0	0	1,223	170	0	0	1
			T5TM	1,133	161	0	0	1,186	166	0	0	1,245	172	0	0	1,238	170	0	0	1,238	170	0	0	1
P2	16W	T1S	1,881	95	0	0	1,886	99	0	0	1,981	104	0	0	1,957	103	0	0	1,957	103	0	0	1	
			T2M	1,875	96	0	0	1,963	103	0	0	1,980	109	0	0	1,957	107	0	0	1,957	107	0	0	1
			T3M	1,876	96	0	0	1,964	103	0	0	1,982	109	0	0	1,958	10							

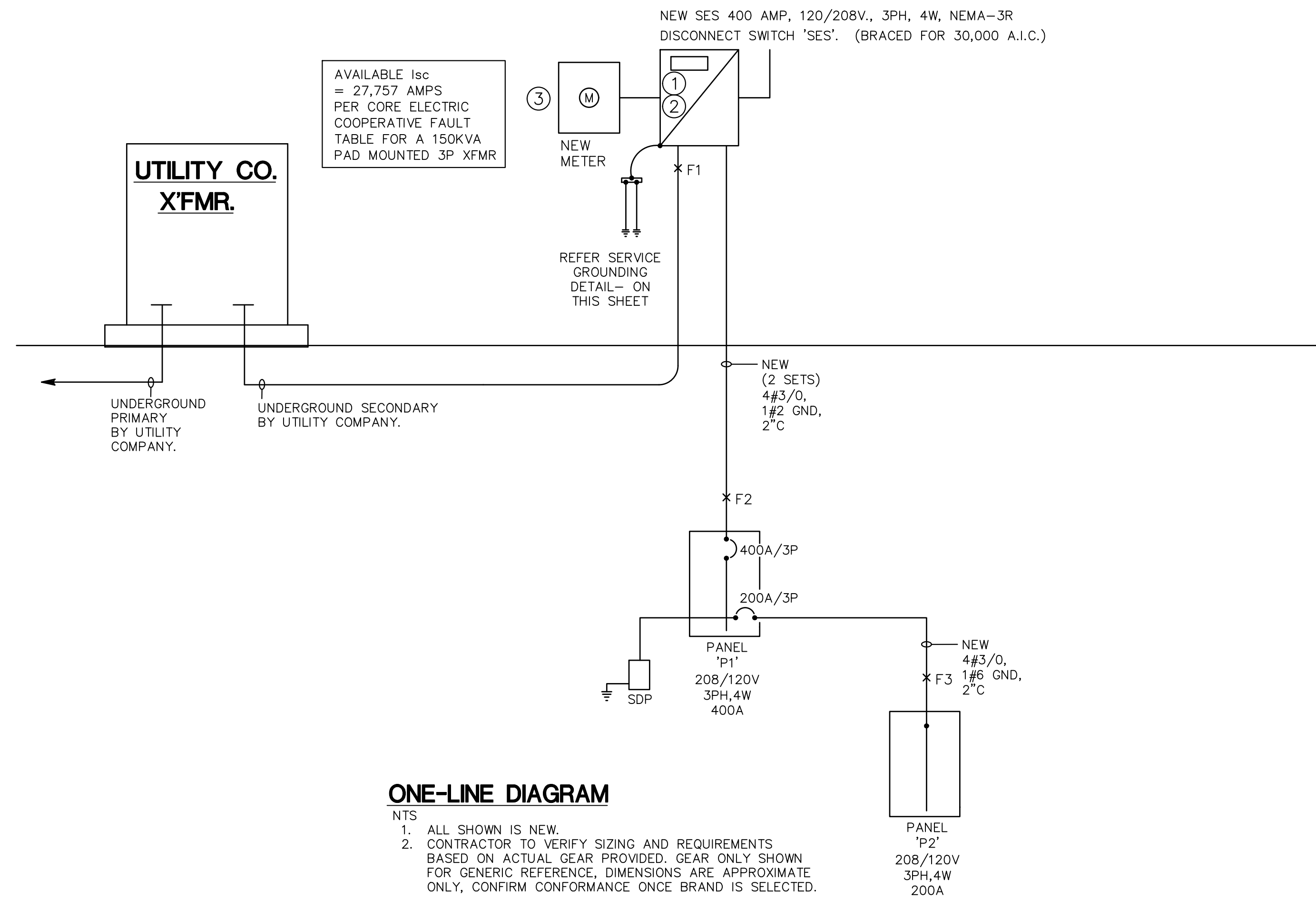

ONE-LINE DIAGRAM

- NTS
1. ALL SHOWN IS NEW.
 2. CONTRACTOR TO VERIFY SIZING AND REQUIREMENTS BASED ON ACTUAL GEAR PROVIDED. GEAR ONLY SHOWN FOR GENERIC REFERENCE. DIMENSIONS ARE APPROXIMATE ONLY. CONFIRM CONFORMANCE ONCE BRAND IS SELECTED.

ELECTRICAL SERVICE NOTE

PRIOR TO PURCHASE OF MAIN SERVICE ENTRANCE EQUIPMENT, VERIFY PROPOSED SERVICE IS ACCEPTABLE TO BOTH UTILITY COMPANY AND A.H.J. NOTIFY THE ENGINEER OF REJECTIONS AND COMMENTS PERTINENT TO THE MAIN SERVICE ENTRANCE EQUIPMENT.

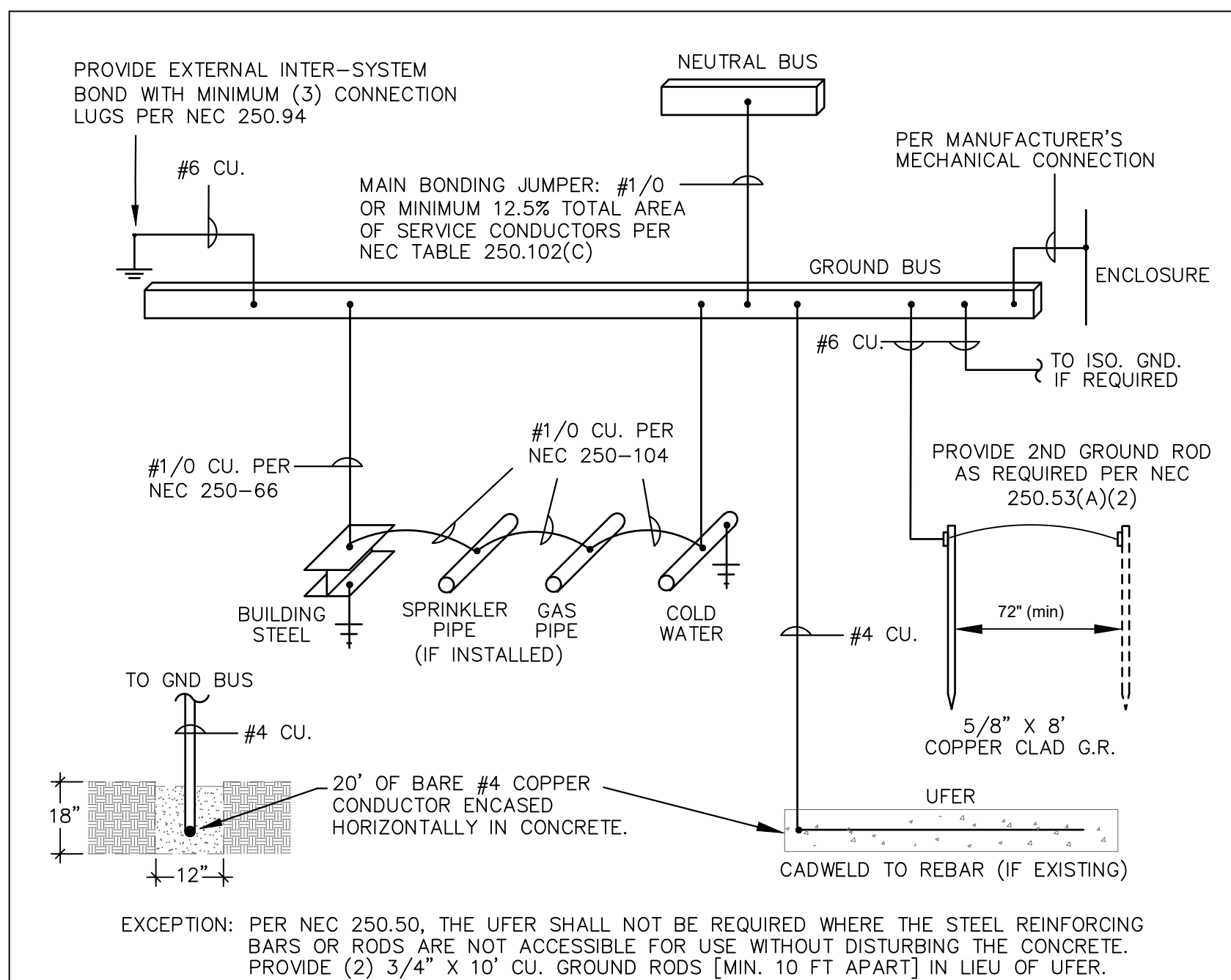

SERVICE GROUNDING DETAIL

NOT TO SCALE

GENERAL NOTES

- THESE REQUIREMENTS ARE PROVIDED IN ACCORDANCE WITH THE NATIONAL ELECTRIC CODE, ARTICLE 250 PERTAINING TO 'GROUNDING ELECTRODE SYSTEMS'.
- 1) THE METALLIC PIPING BOND, BUILDING STEEL BOND, AND THE 2ND SERVICE BONDING MUST BE BONDED TOGETHER AND TO THE GROUNDING ELECTRODE SYSTEM IF PRESENT.
 - 2) ALL SPLICING SHALL BE EXOTHERMIC WELDS (CAD WELDS).
 - 3) ALL INSTALLATIONS SHALL COMPLY WITH THE LATEST ADOPTED EDITION OF NEC ARTICLE 250 AND ANY STATE AND/OR LOCAL REQUIREMENTS.
 - 4) THE GROUNDING SYSTEM SHALL PROVIDE LESS THAN 25 OHMS RESISTANCE TO GROUND AT THE SERVICE CONNECTION. INSTALL ADDITIONAL GROUND RODS IF GROUND RESISTANCE EXCEEDS 25 OHMS PER NEC 250.56

DEVICE	FAULT	AIC RATING	L-N VOLTS	UTILITY	FED FROM		FEEDER					TOTAL MOTOR FAULT	DIRECTLY CONNECTED MOTOR LOAD	
					DEVICE	FAULT	SIZE	X / 1000'	R / 1000'	LENGTH	X		R	KVA
SES	27,757	30,000	120V	27,228		(2)#3/0	0.021	0.0385		0	0	529		
F1	DS-1	10,000	120V	9,471	SES	27,228	(2)#3/0	0.021	0.0385	1'	0	0	529	
F2	P1	9,751	120V	9,221	DS-1	9,471	(2)#3/0	0.021	0.0385	12'	0.0003	0.0005	530	23.2 257
F3	P2	9,238	120V	8,736	P1	9,221	#3/0	0.042	0.077	12'	0.0005	0.0009	502	24.6 273

ONE-LINE GENERAL NOTES

- SWITCHBOARD COMPONENTS, INCLUDING OVERCURRENT PROTECTIVE DEVICES SHALL BE FULLY RATED FOR THE AVAILABLE FAULT CURRENT SHOWN.
- PROVIDE ARC FLASH AND SHOCK HAZARD WARNING IDENTIFICATION PER NEC ARTICLE 110.16
- "NO DESIGN CHANGES MAY BE MADE TO THE SYSTEM WITHOUT THE PRIOR APPROVAL OF THE DESIGN ENGINEER AND THE ELECTRICAL INSPECTOR."
- THE FEEDER LENGTHS SHOWN IN THE INPUT DATA IS FOR CALCULATIONS ONLY. IT IS NOT THE INTENT TO USE THESE ENTERED LENGTHS FOR USAGE OF ACTUAL FIELD FEEDER LENGTH MEASUREMENTS.
- PER NEC 240.2 CURRENT LIMITING OVERCURRENT A DEVICE THAT, WHEN INTERRUPTING CURRENTS IN ITS CURRENT-LIMITING RANGE, REDUCES THE CURRENT FLOWING IN THE FAULTED CIRCUIT TO A MAGNITUDE SUBSTANTIALLY LESS THAN THAT OBTAINABLE IN THE SAME CIRCUIT IF THE DEVICE WERE REPLACED WITH A SOLID CONDUCTOR HAVING COMPARABLE IMPEDANCE.
- ALL SWITCHBOARDS, SWITCHGEAR, AND PANELBOARDS SUPPLIED BY FEEDERS SHALL BE PERMANENTLY MARKED TO INDICATE EACH DEVICE OR EQUIPMENT WHERE THE POWER ORIGINATES. THE LABEL SHALL BE PERMANENTLY AFFIXED, OF SUFFICIENT DURABILITY TO WITHSTAND THE ENVIRONMENT INVOLVED, AND NOT HANDWRITTEN PER NEC 408.4(B)

PANEL SCHEDULES GENERAL NOTES

- A.I.C. RATING SHOWN ON PANEL SCHEDULES ARE THE MINIMUM RATING FOR NEW AND REPLACEMENT OVERCURRENT PROTECTIVE DEVICES. EACH DEVICE SHALL BE FULLY RATED AT AFC AS SHOWN ON ONE-LINE DIAGRAM.
- ALL PANEL BOARDS SHALL HAVE A TYPE WRITTEN DIRECTORY IDENTIFYING EACH NUMBERED CIRCUIT PLACED IN A DIRECTORY HOLDER INSIDE THE DOOR.
- THE CONTRACTOR SHALL PERMANENTLY MARK WITH PERMANENT MARKER THE CIRCUIT IDENTIFICATIONS ON THE COVERPLATES OF RECEPTACLES, EQUIPMENT, AND LIGHTING JUNCTION BOXES. (STICK ON LABELS NOT ACCEPTABLE)
- PER NEC 210.4(B) ALL MULTIWIRE BRANCH CIRCUITS ARE TO BE PROVIDED WITH A DEVICE THAT WILL DISCONNECT POWER TO ALL UNGROUNDED CONDUCTORS SIMULTANEOUSLY AT THE POINT OF ORIGIN.
- ALL LIFE SAFETY CIRCUITS SHALL REQUIRE A LOCK ON DEVICE. FIRE ALARM CIRCUITS SHALL HAVE RED IDENTIFICATION AND BE IDENTIFIED AS FIRE ALARM CIRCUIT.
- PER NEC 408.4(A) EVERY CIRCUIT AND CIRCUIT MODIFICATION SHALL BE LEGIBLY IDENTIFIED AS TO ITS CLEAR, EVIDENT AND SPECIFIC PURPOSE OR USE.
- PER NEC 700.12(F)2 INSTALLATION OF UNIT EQUIPMENT, EMERGENCY LIGHTS, EXIT SIGNS & OTHER UNIT EQUIPMENT SHALL BE CLEARLY IDENTIFIED WITHIN & AT THE DISTRIBUTION PANEL.

KEYED NOTES

- PROVIDE WEATHERPROOF PLACARD STATING AVAILABLE FAULT CURRENT AND DATE CALCULATED PER NEC 110.24.
- PROVIDE ARC-FLASH HAZARD WARNING LABEL: LABEL SHALL INDICATE NOMINAL VOLTAGE, AVAILABLE FAULT CURRENT, CLEARING TIME (UNDER SPECIAL INSPECTION) AND THE DATE THE LABEL IS APPLIED PER NEC 110.16(B). MAIN BREAKER SHALL BE LSIG.
- E.C. SHALL INSTALL UTILITY COMPLIANT CT/METER. COORDINATE FINAL APPROVAL WITH LOCAL ELECTRICAL UTILITY COMPANY.



Know what's below. Call before you dig.
 THE LOCATIONS OF EXISTING UNDERGROUND UTILITIES ARE SHOWN IN AN APPROXIMATE WAY ONLY AND HAVE NOT BEEN INDEPENDENTLY VERIFIED BY THE OWNER OR ITS REPRESENTATIVE. THE CONTRACTOR SHALL DETERMINE THE EXACT LOCATION OF ALL EXISTING UTILITIES BEFORE COMMENCING WORK AND AGREE TO BE FULLY RESPONSIBLE FOR ANY AND ALL DAMAGE WHICH MIGHT BE OCCASIONED BY THE CONTRACTOR'S FAILURE TO LOCATE AND PRESERVE ANY AND ALL UNDERGROUND UTILITIES.

NOTICE
 CONSTRUCTION SITE SAFETY IS THE SOLE RESPONSIBILITY OF THE CONTRACTOR. NEITHER THE OWNER NOR THE ENGINEER SHALL BE DEEMED TO ASSUME ANY RESPONSIBILITY FOR THE SAFETY OF THE WORK OF PERSONS ENGAGED IN THE WORK OF ANY NEARBY STRUCTURE, OR OF ANY OTHER PERSONS.
 COPYRIGHT © 2025 ATWELL LLC. NO REPRODUCTION SHALL BE MADE WITHOUT THE PRIOR WRITTEN CONSENT OF ATWELL LLC.

ATWELL
 866.850.4200 www.atwell-group.com
 9001 AIRPORT FREEWAY, SUITE 660
 NORTH RICHLAND HILLS, TX 76180
 972.626.8860

LOT 4A PARKER POINT SUBD. FILING NO. 1. AMEND. NO. 1
 S. PARKER RD & STROH RD
 PARKER
 DOUGLAS COUNTY, COLORADO

BLACK ROCK COFFEE BAR
 13135 DECLAN DRIVE
 ELECTRICAL ONE-LINE DIAGRAM

DATE 2025-06-04

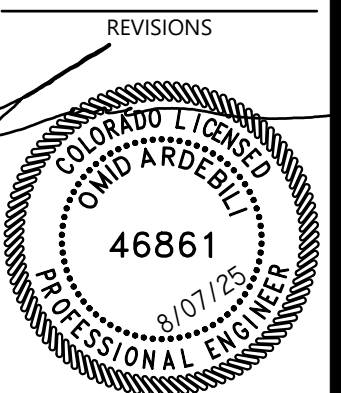

DRAWN BY: AD
 CHECKED BY: PC
 PROJECT MANAGER: AV
 JOB #: 24003198
 FILE CODE: ##
 SHEET NO. E4.0

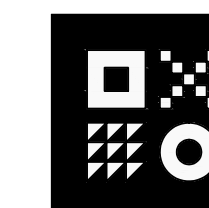

ARDEBILI Engineering
 Project Number: 25280 | Design Engineer: AV
 7328 E Stetson Dr., Scottsdale, AZ 85251
 P: 480.626.7072 | ardebilieng.com

SES		NEW SERVICE						
ROOM ELEC ROOM		VOLTS 208Y/120V 3P 4W			AIC 30,000			
MOUNTING SURFACE		BUS AMPS 400			MAIN BKR 400			
FED FROM UTILITY		NEUTRAL 100%			LUGS STANDARD			
NOTE NEMA 1								
CKT #	CIRCUIT DESCRIPTION	KVA LOAD			FRAME TRIP/POLES	COND.	FEEDER RACEWAY AND CONDUCTORS	
		A	B	C				
1	FUSED DISCONNECT DS-1	41.3	36.7	43.8	400/3	(2)2"C,4#3/0,#1/0G		
TOTAL CONNECTED KVA BY PHASE		41.3	36.7	43.8				
		CONN KVA CALC KVA			CONN KVA CALC KVA			
LIGHTING		1.17	1.46	(125%)	RECEPTACLES	9.01	9.01	(50%>10)
LARGEST MOTOR		19.6	4.9	(25%)	KITCHEN EQUIPMENT	47.8	31.1	(65%)
MOTORS		47.8	47.8	(100%)	CONTINUOUS	4.69	5.86	(125%)
					HEATING	11.4	11.4	(100%)
					TOTAL LOAD	111		
					BALANCED 3-PHASE LOAD	309 A		

P1		NEW PANEL										
ROOM STORAGE AREA		VOLTS 208Y/120V 3P 4W			AIC 22,000							
MOUNTING SURFACE		BUS AMPS 400			MAIN BKR 400							
FED FROM DS-1		NEUTRAL 100%			LUGS STANDARD							
NOTE NEMA 1												
CKT #	BKR	CIRCUIT DESCRIPTION	KVA LOAD			CKT #	BKR	CIRCUIT DESCRIPTION	KVA LOAD			
			A	B	C				A	B	C	
1	20/1	STORAGE AREA RECEPTACLE(S)	0.72			2	20/1	IT CABINET RECEPTACLES(S)	0.72			
3	20/1	DINING AREA RECEPTACLE(S)	1.26			4	20/1	KITCHEN RECEPTACLE(S)	0.9			
5	20/2	E7(ICE MACHINE)			1.42	6	20/1	E14(BUNN GRINDER)			1.32	
7						8	20/1	E9(SWFT GRINDER)	0.78			
9	20/1	#1 E19(UNDER COUNTER REFRIGERATOR)	1.42		0.24	10	30/2	#2 E17(MICROWAVE)	3.1			
11	30/2	#1 E17(MICROWAVE)			3.1	12					3.1	
13						14	20/1	E10(VITAMIX BLENDER)	1.8			
15	20/1	#1 E10(VITAMIX BLENDER)	3.1		1.8	16	20/2	E26(BEVERAGE FREEZER)			1.3	
17	20/1	#2 E19(UNDER COUNTER REFRIGERATOR)			0.24	18						
19	20/1	E20(NITRO BREW COFFEE DISPENSOR)	0.6			20	20/1	POS EQUIPMENT	0.5			
21	20/1	E9(SWIFT GRINDER)	0.78			22	20/1	E18(UNDER COUNTER REFRIGERATOR)	0.5		0.36	
23	30/2	E8(RANCILIO ESPRESSO MACHINE)			3	24	20/1	E27(HOT WATER DISPENSER)			1.85	
25						26	20/1	KITCHEN RECEPTACLE(S)	0.36			
27	20/1	#2 E10(VITAMIX BLENDER)	3		1.8	28	20/1	RO SYSTEM RECEPTACLE(S)	0.37			
29	20/1	#3 E10(VITAMIX BLENDER)			1.8	30	20/1	E10(VITAMIX BLENDER)	1.8			
31	20/1	POS EQUIPMENT	0.5			32	70/3	RTU-1	6.53			
33	-/1	SPACE	0			34					6.53	
35	-/1	SPACE			0	36						
37	200/3	PANEL P2	21.3			38	-/3	SPD	0			
39					18.3	40					0	
41					18.3	42					0	
TOTAL CONNECTED KVA BY PHASE			41.3	36.7	43.8							
TOTAL CONNECTED AMPS BY PHASE			347	306	368							
		CONN KVA CALC KVA			CONN KVA CALC KVA							
LIGHTING		1.17	1.46	(125%)	RECEPTACLES	9.01	9.01	(50%>10)				
LARGEST MOTOR		19.6	4.9	(25%)	KITCHEN EQUIPMENT	47.8	31.1	(65%)				
MOTORS		47.8	47.8	(100%)	CONTINUOUS	4.69	5.86	(125%)				
					HEATING	11.4	11.4	(100%)				
					TOTAL LOAD	111						
					BALANCED 3-PHASE LOAD	309 A						

P2		NEW PANEL										
ROOM STORAGE AREA		VOLTS 208Y/120V 3P 4W			AIC 22,000							
MOUNTING SURFACE		BUS AMPS 200			MLO							
FED FROM P1		NEUTRAL 100%			LUGS STANDARD							
NOTE NEMA 1												
CKT #	BKR	CIRCUIT DESCRIPTION	KVA LOAD			CKT #	BKR	CIRCUIT DESCRIPTION	KVA LOAD			
			A	B	C				A	B	C	
1	40/2	E8(RANCILIO ESPRESSO MACHINE)	3			2	20/1	#1 E10(VITAMIX BLENDER)	1.8			
3					3	4	20/1	#2 E10(VITAMIX BLENDER)	1.8		6.53	
5	35/2	E13(COFFEE BREWER)	2.65		2.65	6	70/3	RTU-2			6.53	
7						8						
9	20/1	DRIVE-THRU SPEAKER, MENUBOARD	2.65		1	10						
11	20/1	KITCHEN AREA LIGHTING			0.378	12	20/1	ROOF RECEPTACLE(S)			0.36	
13	20/2	E6(MOBILE ICE BIN)	1.47			14	20/1	DINING AREA LIGHTING	0.312			
15					1.47	16	20/1	RESTROOM LIGHTING & CEF-1			0.218	
17	20/1	CP-1			0.097	18	50/2	EW-1			4	
19	20/1	EXTERIOR BUILDING LIGHTING	0.219			20						
21	20/1	EXTERIOR SIGNAGE 1	1.2			22	20/1	EXTERIOR SIGNAGE 3			1.2	
23	20/1	EXTERIOR SIGNAGE 2	1.2		1.2	24	20/1	EXTERIOR RECEPTACLE(S)			0.72	
25	20/1	WALK-IN COOLER LIGHTING	0.08			26	20/1	WALK-IN COOLER FAN	0.192			
27	20/1	TIME SWITCH	0.05			28	20/1	E18(UNDER COUNTER REFRIGERATOR)	0.36			
29	20/3	E15(WALK-IN CLR CONDENSER)	0.696		0.696	30	20/1	EUH-1			1.5	
31						32	20/1	DINE-IN AREA LIGHTING	0.174			
33					0.696	34	20/1	BIG FAN			0.75	
35	20/2	EXTERIOR POLE LIGHTING	0.16		0.16	36	-/1	SPACE			0	
37						38	-/1	SPACE			0	
39	-/1	SPACE	0			40	-/1	SPACE			0	
41	-/1	SPACE	0			42	-/1	SPACE			0	
TOTAL CONNECTED KVA BY PHASE			21.3	18.3	18.3							
TOTAL CONNECTED AMPS BY PHASE			178	154	156							
		CONN KVA CALC KVA			CONN KVA CALC KVA							
LIGHTING		1.17	1.46	(125%)	RECEPTACLES	2.61	2.61	(50%>10)				
LARGEST MOTOR		19.6	4.9	(25%)	KITCHEN EQUIPMENT	15.3	11.3	(LARGEST 2)				
MOTORS		24.6	24.6	(100%)	CONTINUOUS	4.69	5.86	(125%)				
					HEATING	9.5	9.5	(100%)				
					TOTAL LOAD	60.3						
					BALANCED 3-PHASE LOAD	167 A						

PANEL SCHEDULES GENERAL NOTES

- A.I.C. RATING SHOWN ON PANEL SCHEDULES ARE THE MINIMUM RATING FOR NEW AND REPLACEMENT OVERCURRENT PROTECTIVE DEVICES. EACH DEVICE SHALL BE FULLY RATED AT AFC AS SHOWN ON ONE-LINE DIAGRAM.
- ALL PANEL BOARDS SHALL HAVE A TYPE WRITTEN DIRECTORY IDENTIFYING EACH NUMBERED CIRCUIT PLACED IN A DIRECTORY HOLDER INSIDE THE DOOR.
- THE CONTRACTOR SHALL PERMANENTLY MARK WITH PERMANENT MARKER THE CIRCUIT IDENTIFICATIONS ON THE COVERPLATES OF RECEPTACLES, EQUIPMENT, AND LIGHTING JUNCTION BOXES. (STICK ON LABELS NOT ACCEPTABLE)
- PER NEC 210.4(B) ALL MULTI-WIRE BRANCH CIRCUITS ARE TO BE PROVIDED WITH A DEVICE THAT WILL DISCONNECT POWER TO ALL UNGROUNDED CONDUCTORS SIMULTANEOUSLY AT THE POINT OF ORIGIN.
- ALL LIFE SAFETY CIRCUITS SHALL REQUIRE A LOCK ON DEVICE. FIRE ALARM CIRCUITS SHALL HAVE RED IDENTIFICATION AND BE IDENTIFIED AS FIRE ALARM CIRCUIT.
- PER NEC 408.4(A) EVERY CIRCUIT AND CIRCUIT MODIFICATION SHALL BE LEGIBLY IDENTIFIED AS TO ITS CLEAR, EVIDENT AND SPECIFIC PURPOSE OR USE.
- PER NEC 700.12(F)2) INSTALLATION OF UNIT EQUIPMENT, EMERGENCY LIGHTS, EXIT SIGNS & OTHER UNIT EQUIPMENT SHALL BE CLEARLY IDENTIFIED WITHIN & AT THE DISTRIBUTION PANEL.

PANELBOARD SYMBOLS

▲	CONTROLLED BY TIME CLOCK/PHOTOCELL (VIA CONTACTOR)
◆	GFCI - GROUND FAULT CIRCUIT INTERRUPTER BREAKER

Technical Data 1020
Effective July 2023

FRN-R Class RK5 250Vac, 125/250Vdc
70-600A, dual element, time-delay fuses

Current-limitation curves:

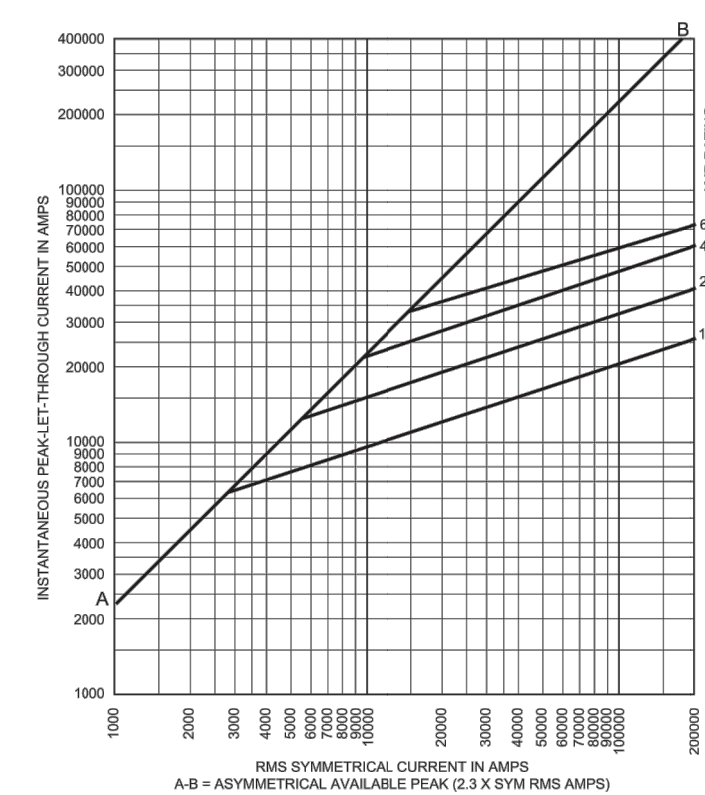

Current-limiting effects:

Prospect S.C.C.	Let-through current (apparent RMS Sym. vs. fuse rating)			
	100A	200A	400A	600A
5000	3000	5000	5000	5000
10000	4000	7000	10,000	10,000
15000	5000	8000	11,000	15,000
20000	5000	8000	12,000	16,000
25000	6000	9000	13,000	17,000
30000	6000	10,000	13,000	18,000
35000	6000	10,000	15,000	19,000
40000	7000	11,000	15,000	20,000
50000	7000	11,000	17,000	21,000
60000	8000	12,000	18,000	22,000
70000	8000	13,000	19,000	23,000
80000	8000	13,000	19,000	24,000
90000	8000	14,000	20,000	25,000
100000	9000	14,000	21,000	26,000
150000	10,000	16,000	24,000	29,000
200000	11,000	18,000	26,000	32,000

FUSE PULL OUT DISCONNECT CLASS RK5 DS-1 TIME-DELAY FUSES.

The only controlled copy of this data sheet is the electronic read-only version located on the Eaton network drive. All other copies of this document are by definition uncontrolled. This bulletin is intended to clearly present comprehensive product data and provide technical information that will help the end user with design applications. Eaton reserves the right, without notice, to change design or construction of any products and to discontinue or limit distribution of any products. Eaton also reserves the right to change or update, without notice, any technical information contained in this bulletin. Once a product has been selected, it should be tested by the user in all possible applications.



For Eaton's Bussmann series product information, call 1-855-287-7626 or visit: Eaton.com/bussmannseries

Follow us on social media to get the latest product and support information.



Know what's below. Call before you dig.
THE LOCATIONS OF EXISTING UNDERGROUND UTILITIES ARE SHOWN IN AN APPROXIMATE WAY ONLY AND HAVE NOT BEEN INDEPENDENTLY VERIFIED BY THE OWNER OR ITS REPRESENTATIVE. THE CONTRACTOR SHALL DETERMINE THE EXACT LOCATION OF ALL EXISTING UTILITIES BEFORE COMMENCING WORK AND AGREE TO BE FULLY RESPONSIBLE FOR ANY AND ALL DAMAGES WHICH MAY BE OCCURRED BY THE CONTRACTOR'S FAILURE TO LOCATE AND PRESERVE ANY AND ALL UNDERGROUND UTILITIES.

NOTICE
CONSTRUCTION SITE SAFETY IS THE SOLE RESPONSIBILITY OF THE CONTRACTOR. NEITHER THE OWNER NOR THE ENGINEER SHALL BE DEEMED TO ASSUME ANY RESPONSIBILITY FOR SAFETY OF THE WORK OF PERSONS ENGAGED IN THE WORK OF ANY NEARBY STRUCTURE, OR OF ANY OTHER PERSONS.

COPYRIGHT © 2023 ATWELL LLC. NO REPRODUCTION SHALL BE MADE WITHOUT THE PRIOR WRITTEN CONSENT OF ATWELL LLC.

ATWELL
866.850.4200 www.atwell-group.com
9001 AIRPORT FREEWAY, SUITE 660
NORTH RICHLAND HILLS, TX 76180
972.656.8860

LOT 4A PARKER POINT SUBD. FILING NO. 1 - AMEND. NO. 1
S. PARKER RD & STROH RD
PARKER
DOUGLAS COUNTY, COLORADO

BLACK ROCK COFFEE BAR
13135 DECLAN DRIVE
ELECTRICAL PANEL SCHEDULES

DATE 2025-06-04

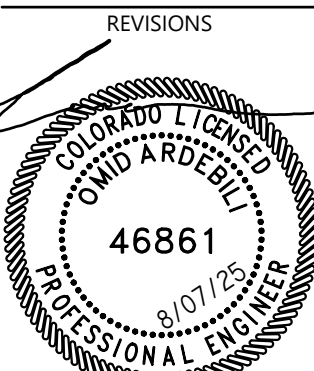

DRAWN BY: AD
CHECKED BY: PC
PROJECT MANAGER: AV
JOB #: 24003198
FILE CODE: ##
SHEET NO. E4.1

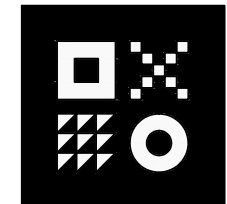

ARDEBILI
Engineering

Project Number: 25280 | Design Engineer: AV
7328 E Stetson Dr., Scottsdale, AZ 85251
P: 480.626.7072 | ardebileng.com

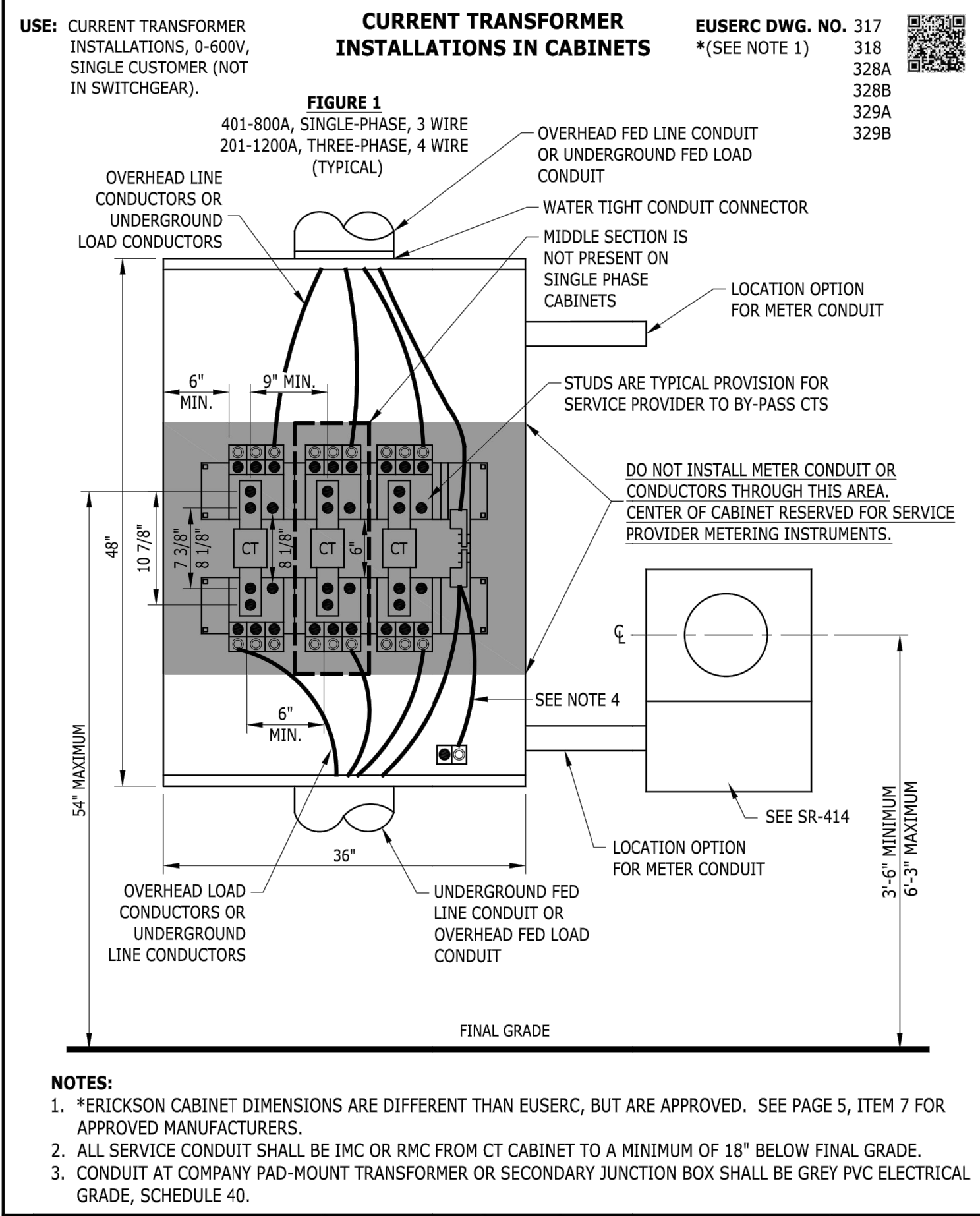

Specifications

400A FUSED DISCONNECT

Eaton DH365NRK

Eaton 400A/3P HD Fusible Safety Switch
600V w/Neut Nema 3R**

General specifications	
PRODUCT NAME	Eaton heavy duty fusible safety switch
CATALOG NUMBER	DH365NRK
UPC	782113207261
PRODUCT LENGTH/DEPTH	44.76 in
PRODUCT HEIGHT	12.39 in
PRODUCT WIDTH	24.12 in
PRODUCT WEIGHT	151 lb
WARRANTY	Eaton Selling Policy 25-000, one (1) year from the date of installation of the Product or eighteen (18) months from the date of shipment of the Product, whichever occurs first.
COMPLIANCES	NEC 230.62 (C) Compliant Barrier
CERTIFICATIONS	UL Listed

Specifications

400A PULLBOX

Eaton 3MTB400R

Eaton main terminal box, 400A, Aluminum, NEMA 3R, Overhead/underground, Four-wire, Three-phase, 120/208V, (1) #6 AWG-600 kcmil, (2) #1/0 AWG-250 kcmil

General specifications	
PRODUCT NAME	Eaton main terminal box
CATALOG NUMBER	3MTB400R
UPC	786849053086
PRODUCT LENGTH/DEPTH	6.5 in
PRODUCT HEIGHT	7.5 in
PRODUCT WIDTH	13.5 in
PRODUCT WEIGHT	54 lb
WARRANTY	Eaton Selling Policy 25-000, one (1) year from the date of installation of the Product or eighteen (18) months from the date of shipment of the Product, whichever occurs first.
CERTIFICATIONS	UL Listed
CATALOG NOTES	For compression lug landing kits, order 3MTB1200CLK (includes landings for 3-phases and neutral).

*USE ONLY AS BASIS OF DESIGN

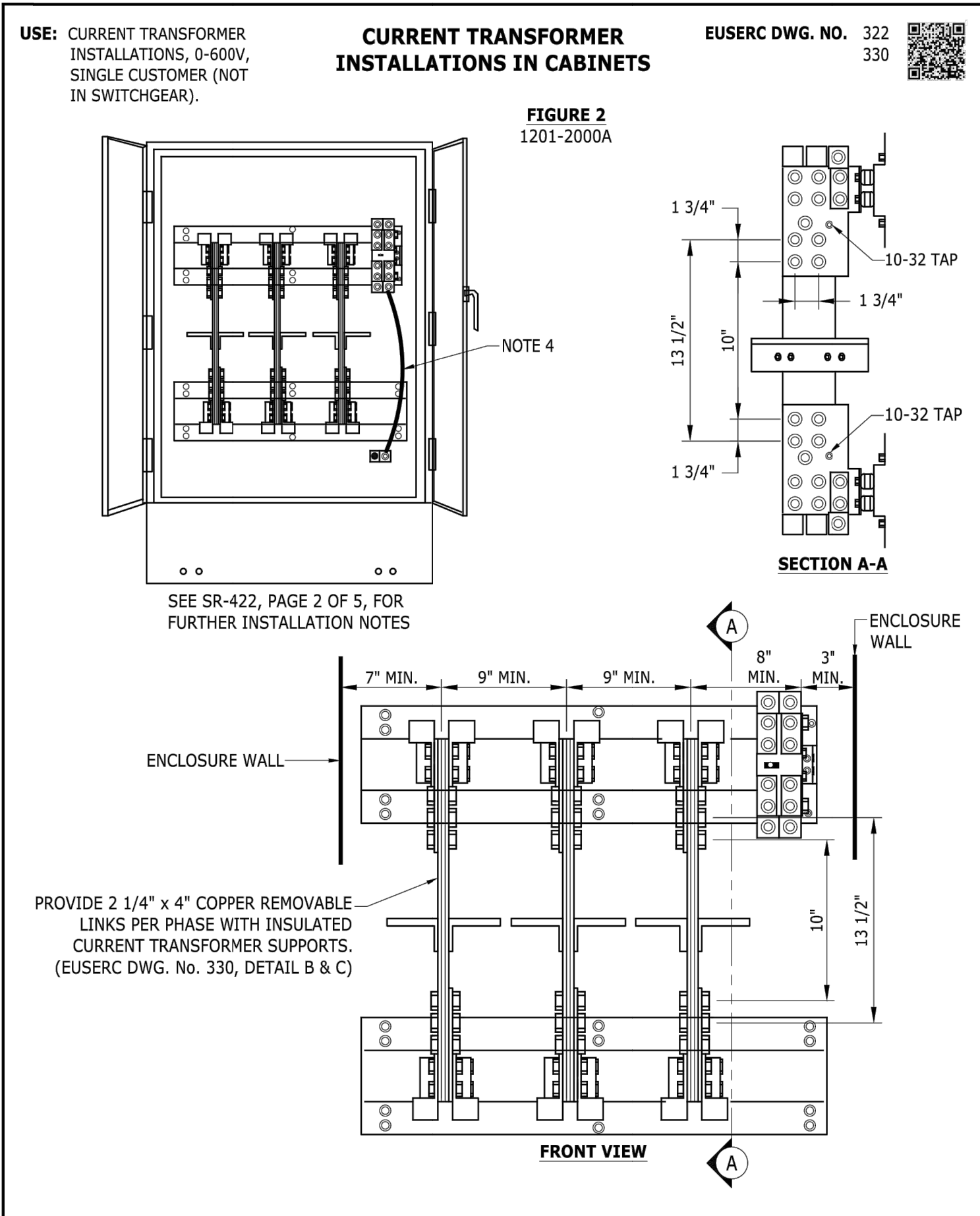

Physical Attributes	
ENCLOSURE	NEMA 3R
ENCLOSURE MATERIAL	Painted galvanized steel
FUSE CLASS PROVISION	Class H
FUSE CONFIGURATION	Fusible with neutral
NUMBER OF POLES	Three-pole
NUMBER OF WIRES	4
TYPE	Heavy duty fusible safety switch

Miscellaneous	
PRODUCT CATEGORY	Heavy Duty, Fusible with neutral

Performance Ratings	
AMPERAGE RATING	400A
HP RATING - MAX	250, 350 hp (3PH @480/600 V)
NEMA RATING	NEMA 3R
VOLTAGE RATING	600 V

Resources	
CATALOGS	Commercial Distribution, Switching Devices, Volume 2, Tab 1
SPECIFICATIONS AND DATASHEETS	Eaton Specification Sheet: DH365NRK

PROJECT NAME: _____
PROJECT NUMBER: _____
PREPARED BY: _____
DATE: _____

EATON
Powering Business Worldwide

Eaton Corporation plc
Eaton House
30 Pembroke Road
Dublin 4, Ireland
Eaton.com

© 2025 Eaton. All Rights Reserved.

Follow us on social media to get the latest product and support information.

[in](#) [X](#) [o](#) [f](#) [v](#)

Product specifications	
AMPERAGE RATING	400A
BUS MATERIAL	Aluminum
FEED TYPE	Top/bottom
PHASE	Three-phase
VOLTAGE RATING	120/208 V
WIRE SIZE	(1) #6 AWG-600 kcmil, (2) #1/0 AWG-250 kcmil
UTILITY APPROVALS	MI: Consumers Energy MI: DTE Energy (Detroit Edison) HI: Hawaiian Electric MT: NorthWestern Energy NE: NorthWestern Energy SD: NorthWestern Energy WY: NorthWestern Energy WI: WE Energies / Wisconsin Public Service (WPS) MD: Baltimore Gas and Electric DC: PEPCO MD: PEPCO
ENCLOSURE	NEMA 3R
NUMBER OF WIRES	4

PROJECT NAME: _____
PROJECT NUMBER: _____
PREPARED BY: _____
DATE: _____

EATON
Powering Business Worldwide

Eaton Corporation plc
Eaton House
30 Pembroke Road
Dublin 4, Ireland
Eaton.com

© 2025 Eaton. All Rights Reserved.

Resources	
CATALOGS	Residential and Light Commercial, Metering Products, Volume 1, Tab 4
SPECIFICATIONS AND DATASHEETS	Eaton Specification Sheet: 3MTB400R

811
Know what's below. Call before you dig.
THE LOCATIONS OF EXISTING UNDERGROUND UTILITIES ARE SHOWN IN AN APPROXIMATE WAY ONLY AND HAVE NOT BEEN INDEPENDENTLY VERIFIED BY THE OWNER OR ITS REPRESENTATIVE. THE CONTRACTOR SHALL DETERMINE THE EXACT LOCATION OF ALL EXISTING UTILITIES BEFORE COMMENCING WORK, AND AGREES TO BE FULLY RESPONSIBLE FOR ANY AND ALL DAMAGES WHICH MAY BE OCCASIONED BY THE CONTRACTOR'S FAILURE TO LOCATE AND PRESERVE ANY AND ALL UNDERGROUND UTILITIES.

NOTICE
CONSTRUCTION SITE SAFETY IS THE SOLE RESPONSIBILITY OF THE CONTRACTOR. NEITHER THE OWNER NOR THE ENGINEER SHALL BE DEEMED TO ASSUME ANY RESPONSIBILITY FOR SAFETY OF THE WORK, OR PERSONS ENGAGED IN THE WORK, OR ANY NEARBY STRUCTURES, OR OF ANY OTHER PERSONS.

COPYRIGHT © 2025 ATWELL LLC. NO REPRODUCTION SHALL BE MADE WITHOUT THE PRIOR WRITTEN CONSENT OF ATWELL LLC.

ATWELL
866.850.4200 www.atwell-group.com
9001 AIRPORT FREEWAY, SUITE 660
NORTH RICHLAND HILLS, TX 76180
972.626.8860

LOT 4A, PARKER POINTE SUBD. FILING NO. 1, AMEND. NO. 1
S. PARKER RD & STROH RD
PARKER
DOUGLAS COUNTY, COLORADO

BLACK ROCK COFFEE BAR
13135 DECLAN DRIVE
ELECTRICAL GEAR DETAILS

DATE 2025-06-04

REVISIONS

ARDEBILI
46861
PROFESSIONAL INGLETT
9/07/25

DRAWN BY: AD
CHECKED BY: PC
PROJECT MANAGER: AV
JOB #: 24003198
FILE CODE: ##
SHEET NO. E4.2

ARDEBILI
Engineering

Project Number: 25280 | Design Engineer: AV
7328 E Stetson Dr., Scottsdale, AZ 85251
P: 480.626.7072 | ardebileng.com

ELECTRICAL SPECIFICATIONS

16001 SCOPE OF WORK

THE WORK DESCRIBED UNDER THIS SECTION OF THE SPECIFICATIONS INCLUDES FURNISHING ALL MATERIAL LABOR AND EQUIPMENT, EXCEPT AS FURNISHED UNDER OTHER SECTIONS OF THE SPECIFICATIONS, TO INSTALL ALL ELECTRICAL WORK AS SHOWN IN THE DRAWINGS AND AS SPECIFIED AND REFERRED TO HEREIN.

01 EXAMINATION OF THE PREMISES

THE CONTRACTOR WILL BE HELD TO HAVE EXAMINED THE PREMISES AND SATISFIED HIMSELF AS TO EXISTING CONDITIONS UNDER WHICH HE WILL BE OBLIGATED TO OPERATE IN PERFORMING HIS PART OF THE WORK OR THAT WHICH WILL IN ANY MANNER AFFECT THE WORK UNDER HIS CONTRACT.

PRIOR TO ORDERING ANY MATERIALS OR DOING ANY WORK , VERIFY THE DIMENSIONS AT THE SITE, CORRECTNESS OF DIMENSIONS WILL BE THIS CONTRACTORS RESPONSIBILITY. NO EXTRA CHARGES OR COMPENSATION WILL BE ALLOWED FOR DIFFERENCES BETWEEN ACTUAL DIMENSIONS AND DIMENSIONS INDICATED ON THE DRAWINGS. IMMEDIATELY REPORT DIFFERENCES TO THE ARCHITECT AND DO NOT PROCEED WITH WORK UNTIL ARCHITECT RENDERS HIS DECISION.

02 REGULATIONS, PERMITS, AND INSPECTIONS

REGULATIONS: COMPLY WITH ALL APPLICABLE CODES, RULES , AND REGULATIONS. ALL MATERIALS, EQUIPMENT, AND WORK MUST COMPLY WITH THE LATEST ADOPTED EDITION OF THE NATIONAL ELECTRICAL CODE AND THE APPLICABLE MUNICIPAL AND LIFE SAFER CODES.

PERMITS: OBTAIN AND PAY FOR ALL PERMITS, FEES , AND LICENSES REQUIRED TO PERFORM WORK DESCRIBED HEREIN.

INSPECTIONS: ALL WORK MUST BE INSPECTED AND APPROVED BY LOCAL AUTHORITIES. PRIOR TO FINAL APPROVAL, FURNISH THE ARCHITECT WITH CERTIFICATES OF INSPECTION AND APPROVALS BY THE LOCAL AUTHORITIES.

03 WORK LISTED ELSEWHERE

FURNISHING AND INSTALLING MOTOR CONTROLS UNLESS IN MOTOR CONTROL CENTER. FURNISHING HOLE CUTTING IN PRE CAST STRUCTURAL CONCRETE.

04 EXISTING SERVICES AND REMODEL AREAS

MAINTAIN ALL SERVICES, POWER, SOUND, TELEPHONE, ETC. TO EXISTING BUILDINGS OR AREAS. INTERRUPTIONS OF SERVICES REQUIRED FOR "CUT-OVER" OR CONNECTIONS OF NEW CABLES, ETC. SHALL BE DONE AT THE CONVENIENCE OF THE TENANT AND BE APPROVED IN WRITING BY THE TENANT PRIOR TO THE INTERRUPTION.

05 TEMPORARY POWER

PROVIDE TEMPORARY POWER AS REQUIRED BY THE GENERAL CONTRACTOR. THIS SERVICE SHALL BE MAINTAINED THROUGHOUT THE ENTIRE JOB AS THE WORK PROGRESSES.

PROVIDE OUTLETS AT CONVENIENT POINTS AND IN SUFFICIENT NUMBERS SO THAT NO EXTENSION CORD IS OVER 50 FEET IN LENGTH IS REQUIRED TO REACH ANY WORK POINT. MAINTAIN GENERAL LIGHTING IN CORRIDORS, STAIRS, BASEMENT AND OTHER AREAS NOT RECEIVING DAYLIGHT REQUIRED FOR SAFETY. REMOVE TEMPORARY WORK AS RAPIDLY AS REQUIRED FOR OR ALLOWED BY INSTALLATION OF PERMANENT WORK.

16420 SERVICE ENTRANCE EQUIPMENT

SERVICE ENTRANCE EQUIPMENT TO HAVE SHORT CIRCUIT CURRENT RATING EQUAL TO OR GREATER THAN AVAILABLE FAULT CURRENT, AND MEET ALL THE REQUIREMENTS OF U.L. STANDARD NO. 891. OUTDOOR GEAR TO BE NEMA 3R. ALL SWITCHGEAR TO BE FREE STANDING, UNLESS OTHERWISE INDICATED, MOUNTED ON 4" CONCRETE PAD EXTENDING A MINIMUM OF 6 INCHES IN FRONT OF EQUIPMENT.

END SECTION SHALL BE PROVIDED WITH FULL CAPACITY THROUGH BUS FOR FUTURE EXTENSION TO FUTURE SECTIONS.

16425 SWITCHBOARDS

SWITCHBOARDS TO BE SQUARED D TYPE QMB OR EQUAL, FREE STANDING, 90" HIGH, MIN. 14" DEEP WITH TYPE QMB SWITCHES. END SECTION WITH FULL CAPACITY THRU - BUS FOR FUTURE SECTION. MOUNT ON 4" CONCRETE PAD EXTENDING A MINIMUM OF 6 INCHES IN FRONT OF SWITCHBOARDS.

16440 SAFETY SWITCHES

SAFETY SWITCHES SHALL BE HEAVY DUTY TYPE, WHERE OUTSIDE THE BUILDING, THE SWITCHES SHALL BE RAINIGHT TYPE NEMA 3R. ALL SWITCHES SHALL BE LOCKABLE.

16471 PANELS

PANEL TYPE AS INDICATED ON THE DRAWINGS. NEW FLUSH PANELS TO HAVE (3) 3/4" EMPTY CONDUITS STUBBED INTO ACCESSIBLE CEILING SPACE.

PROVIDED A GROUND BUS IN ALL PANELS INCLUDING EXISTING PANELS WHEREIN WORK IS DONE OR LOADS ADDED. CHECK ALL BREAKERS. REPLACE DEFECTIVE BREAKERS IN AFOREMENTIONED PANELS.

VERIFY THE INTERRUPTING CAPACITY OF ALL BREAKERS WITH REQUIREMENT INDICATED ON THE DRAWINGS. REPLACE EXISTING BREAKERS NOT MEETING REQUIRED A.I.C. RATING.

16461 DRY TYPE TRANSFORMERS (IF ANY)

SHALL BE EQUAL TO SQUARE D, 150 DEGREE TEMPERATURE RISE; SERIES 7410/7411. CLEARANCE ALL AROUND PER MANUFACTURERS RECOMMENDATION. PROVIDE ISOLATION PADS.

16510 LIGHTING FIXTURES

FLOURESCENT FIXTURES SHALL BE FURNISHED WITH UL LISTED HIGH POWER-FACTOR BALLASTS. CONTRACTOR SHALL VERIFY CEILING CONSTRUCTION BEFORE ORDERING RECESSED UNITS AND SHALL PROVIDE PLASTER OR DRY WALL FRAMES AS REQUIRED.

RECESSED INCANDESCENT FIXTURES AND FLOURESCENT DOWN LIGHTS SHALL BE LISTED FOR USE IN INSULATED CEILING SPACES, AND SHALL HAVE ANY REQUIRED FEED-THRU BOXES. LAMPS FOR INCANDESCENT FIXTURES SHALL BE 1000 HOUR INSIDE FROSTED 130 VOLT, NOT EXCEEDING THE WATTAGE FOR WHICH THE FIXTURE IS LABELED AND SHALL BE OF THE TYPE RECOMMENDED BY THE FIXTURE MANUFACTURE. LAMPS SHALL BE OF THE SAME MANUFACTURE AS FLOURESCENT.

ALL FIXTURES SHALL BE PROPERLY SUPPORTED FROM CEILING STRUCTURE, NOT FROM GYPBOARD OR PLASTER. SURFACE OR PENDANT MOUNT FLOURESCENT FIXTURES SHALL BE BOLTED TOGETHER FOR PROPER ALIGNMENT AND BONDING.

ALL FLOURESCENT FIXTURES RECESSED IN THE CEILING OR IN A GRID CEILING SHALL BE PROVIDED WITH EARTHQUAKE CLIPS AS REQUIRED BY CODE.

16195 NAME PLATES

PROVIDE CONTRAST PLASTIC EMBOSSING TAPE, ADHESIVE BAKED NAMEPLATES FOR ALL STARTERS AND DISCONNECT SWITCHES.

PROVIDE LAMICOD NAMEPLATES FOR ALL DISTRIBUTION SWITCHES, BREAKERS, LIGHTING AND POWER PANELS INDICATING ITEMS SERVED. SIZE OF LETTERS SHALL BE MINIMUM OF 3/16" HIGH.

16120 WRE

ALL WIRE AND CABLE SHALL BE NEW, 600 VOLT INSULATED, OF TYPES SPECIFIED BELOW. ALL WIRE AND CABLE SHALL BEAR THE UNDERWRITERS' LABEL AND SHALL BE BROUGHT TO THE JOB IN UNBROKEN PACKAGES. WIRE SHALL BE COLORED CODED PER NEC.

BRANCH CIRCUIT WIRING SHALL BE A MINIMUM #12 AWG COPPER

WIRE AND CABLE NO. 4 AWG AND SMALLER SHALL BE TYPE THW OR THHN/THWN

WIRE AND CABLE LARGER THAN NO. 4 AWG SHALL BE TYPE XHHW. ALL AIR CONDITIONING FEEDERS SHALL BE TYPE XHHW.

ALL WIRING IN PANELBOARDS, SWITCHBOARDS, AND GUTTERS SHALL BE NEATLY ARRANGED. WIRE SHALL BE HELD BUNDLED BY TY-RAPS. WIRES SHALL BE CONNECTED TO CIRCUIT BREAKERS, SWITCHES AND OTHER DEVICES PERPENDICULAR TO TERMINAL LUGS.

ALL WIRING IN MANHOLES, PULL BOXES OR JUNCTION BOXES OVER 12 INCHES IN LENGTH SHALL BE BUNDLED IN A NEAT AND ORDERLY MANNER.

AFTER COMPLETION OF UNDERGROUND SPLICES AND SPLICES IN MANHOLES, SEAL SPLICES WITH SCOTCHCOAT #82 COATING OR EQUAL TO MOISTURE PROOF CABLES.

LEAVE NO LESS THAN 6 INCHES OF WIRE AT EACH OUTLET FOR CONNECTION TO LIGHTING FIXTURES, SWITCHES, RECEPTACLES AND OTHER PIECES OF EQUIPMENT. WHERE WIRES FEED THROUGH AN OUTLET OR JUNCTION BOX, NEATLY TUCK 6 INCH LOOP IN BOTTOM OF BOX.

LIGHTING AND POWER CIRCUITS SHALL BE IDENTIFIED BY PANEL LETTER AND CIRCUIT NUMBER WITH BRADY WRAPAROUND CLOTH WIRE MARKERS AT ALL TERMINATIONS AND JUNCTIONS.

ALL BRANCH CIRCUIT AND FEEDER CONDUCTORS SHALL BE COLOR-CODED AS FOLLOWS:

FOR ALL 120 V TO GROUND CIRCUITS; PHASE CONDUCTORS - BLACK, RED, BLUE NEUTRAL CONDUCTOR - WHITE

FOR ALL 277 V TO GROUND CIRCUITS; PHASE CONDUCTORS - BROWN, ORANGE, YELLOW NEUTRAL CONDUCTORS - GRAY

LARGE FEEDER CONDUCTORS SHALL BE CODED BY COLORED TAPE WRAPPED AROUND THE CONDUCTOR AT EACH PULLBOX, TERMINATION POINT AND SPLICE.

ALL CONNECTIONS TO CIRCUIT BREAKERS AND SWITCHES AND ALL JOINTS IN WIRES SHALL BE MADE AS NOTED BELOW:

CONNECTIONS TO CIRCUIT BREAKERS AND SWITCHES: NO. 12 WIRE SHALL BE FORMED AROUND BINDING POST OR SCREW. NO. 10 AND 8 WIRE - BUCHANAN, "TERMED" OR APPROVED EQUAL, LOCKING TONGUE LUG. NO. 6 WIRE AND LARGER - BURNDY "QUICK-LUG" TYPE ODA, OR APPROVED EQUAL, ROUND FLANGE SOLDERLESS LUG.

FIXTURE CONNECTIONS: CIRCUIT WIRING CONNECTIONS TO FIXTURE WIRE SHALL BE MADE WITH PRESSURE-TYPE SOLDER-LESS CONNECTORS - BUCHANAN, SCOTCHLOC OR WING NUT OR APPROVED EQUAL, COMPLETE WITH INSULATOR AND SECURITY RING.

JOINTS IN WIRES: NO. 6 WIRE AND LARGER - BURNDY OR APPROVED EQUAL. NO. 8 WIRE AND SMALLER - BUCHANAN, SCOTCHLOC, WING NUT, OR EQUAL, PRESSURE-TYPE SOLDERLESS CONNECTORS COMPLETE WITH INSULATOR AND SECURITY RING.

CONTROL WIRING AND ALL OTHER STANDARD WIRING TO SCREW CONNECTIONS SHALL BE PROVIDED WITH T AND B STA-KON TERMINALS. SOLID CONDUCTORS SHALL LOOP TIGHTLY AND COMPLETELY AROUND TERMINAL SCREWS ON ALL WIRING DEVICES.

UNINSULATED SOLDERLESS CONNECTORS TO BE INSULATED AS FOLLOWS: TAPE WITH A COVERING OF RUBBER TAPE, EQUAL IN THICKNESS TO THE INSULATION. THIS SHALL BE FOLLOWED WITH AN OUTER COVERING OF FRICTION TAPE IN TWO LAYERS. ONE COAT OF WATERPROOF PAINT SHALL BE APPLIED WHEN SUBJECT TO MOISTURE.

WIRE AND CABLE TO BE PULLED INTO CONDUITS WITHOUT STRAIN, USE POWDERED SOAPSTONE, MINERALAC, OR OTHER APPROVED LUBRICANT. WIRE SHALL NOT BE RE-PULLED IF SAME HAS BEEN PULLED OUT OF A CONDUIT RUN. NO CONDUCTOR SHALL BE PULLED INTO CONDUIT UNTIL CONDUIT SYSTEM IS COMPLETE, INCLUDING JUNCTION BOXES, PULL BOXES, ETC., WITHOUT PERMISSION OF ARCHITECT.

16110 CONDUIT

IN GENERAL, ELECTRICAL METALLIC TUBING SHALL BE USED FOR ALL WIRING EXCEPT IN OR UNDER CONCRETE, EARTH, OR FILL. ELECTRICAL METALLIC TUBING MAY BE USED IN FURRED SPACES, WOOD FRAME WALLS WHERE CONDUITS DO NOT EXCEED 2 1/2" IN SIZE, BRICK, BLOCK, TILE, AND CONCRETE WALLS ARE NOT CONSIDERED HOLLOW AND RIGID CONDUIT SHALL BE PROVIDED FOR THESE AREAS.

01 RIGID STEEL CONDUITS OR INTERMEDIATE METAL CONDUITS SHALL BE USED IN CONCRETE SLABS, IN SOLID GROUTED CELLS OR CONCRETE MASONRY WALLS, BRICK, OR TILE WALLS. FOR ALL EXPOSED CONDUIT OUTSIDE OF THE BUILDING, AND FOR CONDUITS EXCEEDING 2 1/2" IN SIZE, IN ADDITION ALL WIRING IN OR UNDER CONCRETE, EARTH, OR FILL SHALL BE RIGID GALVANIZED OR SHERARDIZED STEEL RIGID CONDUIT UNDER CONCRETE, IN EARTH, OR FILL SHALL BE COATED WITH POLYETHYLENE TAPE. SCOTCH NO. 50 OR APPROVED EQUAL, SPIRAL WRAPPED 1/2" LAPPED TO AN OVERALL THICKNESS OF NOT LESS THAN 15 MILS.

02 USE FLEXIBLE METAL CONDUITS FOR RECESSED FIXTURES, MOTOR, TRANSFORMER AND OTHER EQUIPMENT SUBJECT TO MOVEMENT, USE LIQUID TIGHT TYPE WHERE EXTERIOR OR SUBJECT TO LIQUID SPRAY OR DRIPPING.

03 UL LISTED SCHEDULE 40 PVC CONDUIT MAY BE USED FOR UNDERGROUND RUNS. EXPANSION JOINTS AT 75 FEET ON CENTER OR AS REQUIRED BY MFR. ALL BENDS SHALL BE MANUFACTURED.

04 NON-METALLIC CONDUIT INSTALLED BELOW CONCRETE FLOORS MAY BE INSTALLED IN THE FILL, HOWEVER, A PORTION OF THE CONCRETE FILL MATERIAL MUST BE PLACED AROUND THE CONDUIT FOR RIGID SUPPORT. NON-METALLIC CONDUIT OUTSIDE THE FILL SHALL BE BURIED A MINIMUM OF 18" BELOW GRADE. NON-METALLIC CONDUIT SHALL BE PROVIDED WITH CODE SIZE COPPER BOND WIRE INSIDE THE CONDUIT FOR ELECTRICAL CONTINUITY, AND SHALL BE INSTALLED IN ACCORDANCE TO NEC ARTICLE NO. 250. WRAPPED RIGID STEEL ELBOWS SHALL BE USED FOR RISERS ON PVC CONDUIT RUNS AND SHALL BE GROUND.

ALL FLOURESCENT FIXTURES RECESSED IN THE CEILING OR IN A GRID CEILING SHALL BE PROVIDED WITH EARTHQUAKE CLIPS AS REQUIRED BY CODE.

CONDUIT PLACED IN A CONCRETE SLAB SHALL BE LARGER THAN 3/4" TRADE SIZE DIAMETER AND CONDUIT SMALLER THAN 3/4" SHALL BE USED FOR UNDERGROUND CIRCUITS. CONDUIT SHALL HAVE MINIMUM 1" CONCRETE COVER. NO CONDUIT SHALL BE IMBEDDED IN A SLAB THAT IS LESS THAN 3-1/2" THICK, EXCEPT FOR LOCAL OFFSETS. NO CONDUIT SHALL BE PLACED BETWEEN THE REINFORCING STEEL AND THE BOTTOM OF THE SLAB.

ALL CONDUIT UNDER CONCRETE DRIVES OR ANY LOCATION WHERE SUBJECT TO DAMAGE BY HEAVY EQUIPMENT SHALL BE INSTALLED A MINIMUM OF 24" BELOW GRADE OR 18" BELOW GRADE ENCASED IN A 3" THICK CONCRETE ENVELOPE.

TRENCHING, BACKFILLING, AND CONCRETE WORK FOR ELECTRICAL WORK SHALL BE DONE UNDER THIS SECTION AND AS REQUIRED BY LOCAL AND/OR RULING AUTHORITIES AND REGULATING AGENCIES.

THE CONTRACTOR SHALL PROVIDE ALL NECESSARY SLEEVES AND CHASES REQUIRED WHERE CONDUITS PASS THROUGH FLOORS OR WALLS, AND SHALL SEAL ALL OPENING AND FINISH TO MATCH ADJACENT SURFACES. WHERE EXPOSED CONDUITS PASS THROUGH WALLS, FLOORS, OR CEILINGS, ESUTOICHEON PLATES SHALL BE PROVIDED.

ALL NECESSARY SERVICES AND BLOCKOUTS SHALL BE PROVIDED.

ALL EMPT CONDUITS SHALL BE PROVIDED WITH PULL WIRE.

05 RIGID CONDUIT FITTINGS

PROVIDE DOUBLE LOCKNUTS AND BUSHINGS EXCEPT AT THREADED HUBS.

06 EMT OR FLEX FITTINGS

FOR EMT, OR MALLEABLE IRON, COMPRESSION TYPE ONLY. FOR FLEXIBLE CONDUIT, COMPRESSION OR CLAMP TYPE CONNECTORS SHALL HAVE INSULATED THREADS.

07 MC CABLE

METAL CLAD CABLE MAY BE USED IN LIEU OF EMT CONDUIT AND WIRE FOR BRANCH CIRCUIT WIRING IF ACCEPTABLE TO AUTHORITIES.

16140 WIRING DEVICES

RECEPTACLES SHALL BE FURNISHED AS INDICATED BELOW:

Table with 2 columns: Description (e.g., 20 AMP 120 VOLT DUPLEX) and Manufacturer/Part Number (e.g., HUBBELL #5362 W/#8 COVERPLATE)

WHEN SURFACE WEATHERPROOF MOUNTING IS REQUIRED, RECEPTACLES SHALL BE MOUNTED IN AN FS CONDUIT BOX.

ELEVATION OF EACH RECEPTACLE SHALL BE AT THE FLOOR PLUS 18" TO CENTER UNLESS OTHERWISE NOTED.

ALL SWITCHES SHALL BE FURNISHED IN ACCORDANCE WITH THE FOLLOWING TABLE. SWITCHES SHALL BE OF THE SAME MANUFACTURER AS THE RECEPTACLES FURNISHED.

Table with 2 columns: Description (e.g., 20 AMP 1 POLE) and Manufacturer/Part Number (e.g., HUBBELL #1221-1 WITH #P1 COVERPLATE)

COVERPLATES FOR RECEPTACLES, SWITCHES AND OUTLETS SHALL GENERALLY BE PLASTIC, WITH COLOR AS SELECTED BY THE ARCHITECT.

16130 BOXES

BOXES IN EXPOSED OR WET LOCATIONS SHALL BE CAST STEEL CONDUIT BODIES. IN CONCEALED LOCATIONS, THEY SHALL BE SHEET STEEL BOXES WITH GALVANIZED OR SHERARDIZED FINISH, NEOPRENE GASKETED, SCREWED COVERS.

SHEET STEEL BOXES SHALL BE STANDARD ONE-PIECE KNOCKOUT BOXES. WHERE OUTLETS ARE INSTALLED IN CONCRETE SLABS, BOXES SHALL BE CONCRETE CAST TYPE BOXES. BOXES SHALL NOT BE LESS THAN 4" IN DIAMETER AND 1-1/2" DEEP. OUTLET BOXES SET IN CONCRETE SHALL BE SET TO HAVE FINAL OPENING FLUSH WITH FINISH SURFACE.

CAST-METAL CONDUIT BODIES SHALL BE CROUSE-HINDS CONDUITS, APPLETON UNLETS, OR APPROVED EQUIVALENT. BOXES SHALL BE ARRANGED WITH THREADED CONNECTORS FOR RIGID CONDUIT. ALL CONDUIT BODIES SHALL HAVE SUITABLE COVERS, WHICH SHALL BE PROVIDED WITH GASKET FOR EXTERIOR AND MOST LOCATIONS.

POWER / PHONE FLOOR OUTLETS SHALL BE STEEL CITY #664 WITH # 664CST COVER (VERIFY COLOR), #664-BP PHONE PLATE, #664RP RECEPTACLE PLATE AND 20A DUPLEX RECEPTACLE. PHONE COMPARTMENT TO HAVE 3/4" E.C. TO CEILING SPACE WA FLOOR / WALL.

OUTLETS SET IN FURRED CEILING AND STUD WALLS SHALL BE ANCHORED TO THE CEILING OR WALL STRUCTURE WITH SUITABLE STEEL STRAPS.

OUTLET BOXES SHALL BE USED AS PULL AND JUNCTION BOXES WHEREVER POSSIBLE AND WHERE REQUIRED. BOXES IN PLASTERED WALLS OR CONCRETE BLOCK WALLS IN FINISHED AREAS AND CEILINGS SHALL HAVE TWO GANG RAIKED PLASTER RINGS AND BLANK WALL PLATE. OTHER BOXES SHALL HAVE BLANK COVERS.

WHERE OTHER THAN OUTLET BOXES ARE REQUIRED, PULL AND JUNCTION BOXES SHALL BE CONSTRUCTED OF GALVANIZED STEEL CONFIRMING TO CODE REQUIREMENTS. EXTERIOR BOXES SHALL BE OF WEATHERPROOF CONSTRUCTION AND SHALL BE PROVIDED WITH NEOPRENE COVER GASKETS. BOXES SHALL BE RIGIDLY ATTACHED TO THE STRUCTURE, INDEPENDENT OF ANY CONDUIT SUPPORT.

HANGERS / INSERTS

FURNISH AND INSTALL ALL UNISTRUT, HANGERS, SUPPORTS, ETC. REQUIRED FOR WORK UNDER THIS DIVISION. SUPPORT CONDUIT FROM BUILDING STRUCTURE,NOT FROM CEILING SUPPORTS. BRANCH CIRCUIT CONDUIT 3/4" AND SMALLER MAY BE RUN FROM CEILING SUPPORTS USING SPRING STEEL CLIPS.

CONCRETE, EXCAVATION, FILL, BACKFILL

FURNISH ALL CONCRETE, EXCAVATION, FILL, BACKFILL AND STEEL REQUIRED FOR THIS WORK UNLESS SPECIFICALLY NOTED OTHERWISE.

ALL CONCRETE, FILL, BACKFILL, STEEL, ETC., WHERE REQUIRED SHALL BE IN STRICT ACCORDANCE WITH SPECIFICATIONS SET UP IN OTHER DIVISIONS

OF THE SPECIFICATIONS.

FINAL LOCATION OF SURFACE FEATURES

SHALL BE ACCOMPLISHED IN THE FIELD, SUBJECT TO THE APPROVAL OF THE ARCHITECT. THE LOCATION OF ALL SWITCHES, FIXTURES, PANELS, ETC. AND THEIR PROXIMITY AND RELATIONSHIP TO ALL VISIBLE FEATURES OF EQUIPMENT FURNISHED BY OTHER TRADES, SHALL BE MADE KNOWN TO THE ARCHITECT. IN CASE OF CONFLICT BETWEEN TRADES, OR BETWEEN A TRADE AND THE ARCHITECT, THE DECISION OF THE ARCHITECT SHALL BE FINAL AND HIS INSTRUCTIONS IN THESE MATTERS SHALL BE FOLLOWED BY ALL CONCERNED.

PAINTING

ALL EXPOSED ELECTRICAL EQUIPMENT, CONDUIT, FLUSH PANEL FRONT, TRANSFORMER, SWITCHES, SWITCHBOARDS, PANELS AND SIMILAR ITEMS SHALL BE PAINTED AS SPECIFIED UNDER THE PAINTING SECTION OF THESE SPECIFICATIONS.

CLEANING UP PREMISES

AT ALL TIMES KEEP THE PREMISES FREE FROM ACCUMULATION OF WASTE MATERIAL OR RUBBISH CAUSED BY EMPLOYEES. METAL FLOOR PANS SHALL BE PROVIDED PIPE THREADING MACHINES AND BENCHES AND SHALL BE USED AT ALL TIME TO PREVENT CONCRETE FLOORS BECOMING OIL SOAKED. UPON COMPLETION OF THE JOB, REMOVE ALL DEBRIS, CLEAN ALL SWITCHPLATES, FIXTURES, PANEL TRIMS AND IN GENERAL, LEAVE THE PREMISES IN A CLEAN AND TIDY CONDITION.

ACCEPTABLE MANUFACTURERS

THE FOLLOWING IS A LIST OF MANUFACTURERS WHOSE SPECIFICATION GRADE EQUIPMENT IS ACCEPTABLE AS TO MANUFACTURER. SUBSTITUTIONS SHALL NOT CAUSE OR CONTRIBUTE TO CHANGES UNLESS THESE CHANGES ARE APPROVED BY THE ARCHITECT PRIOR TO SUBSTITUTION.

ITEMS: CAREFUL CHECKING MUST BE MADE TO VERIFY THAT THE EQUIPMENT WILL MEET ALL CAPACITIES, REQUIREMENTS, SPACE ALLOCATIONS, AND THAT THE WEIGHTS ARE NOT EXCESSIVE.

POWER DISTRIBUTION EQUIPMENT: SQUARE D, SIEMENS, CHALLENGER, SUN VALLEY ELECTRIC

WIRE AND CABLES: GENERAL CABLE, ANACONDA, CAPITOL, CIRCLE AW, GENERAL ELECTRIC, OKONITE, ROME, SIMPLEX, KAISER.

LOCAL WALL SWITCHES, RECEPTACLES, PILOT LIGHTS: PASS AND SEYMOUR, SIERRA, BRYANT, CHART F, GENERAL ELECTRIC, HUBBELL, RUSSELL & STOLL, ARROW-HART.

DEVICE PLATES: HUBBELL, SLATER, PASS AND SEYMOUR, SIERRA, BRYANT, ARROW-HART, LEVITON.

LAMPS: GENERAL ELECTRIC, PHILLIPS, SYLVANIA.

CONDUIT: TRIANGLE, NATIONAL ELECTRIC CO., JONES-MCLAUGHLIN REPUBLIC.

FITTINGS: THOMAS AND BETTS, APPLETON, CROUSE-HINDS.

CAST OUTLET BOXES: CROUSE-HINDS, APPLETON.

BALLASTS: ADVANCE, GENERAL ELECTRIC, JEFFERSON, WESTINGHOUSE, SYLVANIA, UNIVERSAL.

FLOOR BOXES: HUBBELL, LEW STEEL CITY.

OUTLET BOXES: RACO, STEEL CITY, SLATER.

SHOP DRAWINGS

ALL DATA SHALL BE SUBMITTED AT ONE TIME, BOUND AND INDEXED IN AN ORDERLY MANNER. PRIOR TO STARTING THE WORK, SUBMIT TO THE ARCHITECT FOR APPROVAL, SIX (6) SETS OF SHOP DRAWINGS OF SERVICE ENTRANCE SECTION, SWITCHBOARDS, PANELBOARDS, LIGHTING FIXTURES,TRANSFORMERS AND ALL EQUIPMENT TO BE FABRICATED.

FINAL INSPECTION AND TEST

FURNISH ALL METERS, CABLES, CONNECTIONS AND APPARATUS NECESSARY FOR MAKING TESTS.

TEST SYSTEM FOR SHORTS AND GROUNDS. FAULTY WIRING SHALL BE REMOVED AND REPLACED. ANY DEVICE, APPARATUS OR FIXTURE INSTALLED SHOWING SUBSTANDARD PERFORMANCE SHALL BE REMOVED AND REPLACED AS DIRECTED BY THE ARCHITECT.

MEGER ALL SYSTEM NEUTRALS IN THE PRESENCE OF THE ENGINEER TO INSURE THE NEUTRAL IS NOT GROUNDED WITHIN THE SYSTEM. TEST SHALL BE MADE AFTER ALL BRANCH CIRCUIT WIRING IS INSTALLED AND CONNECTED.

TEST ALL GROUND FAULT RELAYS IN THE PRESENCE OF THE ENGINEER. SET RELAY FOR TIME AND CURRENT RATING IN ACCORDANCE WITH MANUFACTURER'S RECOMMENDATION.

ALL EQUIPMENT RATED AT 1,000 AMPS OR MORE, OR 480 VOLTS SHALL BE TESTED FOR INSULATION BREAKDOWN PRIOR TO ITS BEING ENERGIZED. SUCH EQUIPMENT SHALL WITHSTAND FOR A PERIOD OF ONE MINUTE WITHOUT BREAKDOWN, THE APPLICATIONS OF A 60HZ ALTERNATING POTENTIAL OF 1,000V PLUS TWICE THE RATED VOLTAGE OF THE DEVICE. TEST SHALL BE PERFORMED IN THE PRESENCE OF THE ENGINEER.

HIGH POTENTIAL TESTING

THE HIGH-POTENTIAL TESTS SHALL BE MADE BY AN INDEPENDENT COMPANY HIRED BY THE ELECTRICAL CONTRACTOR. COPIES OF THE REPORT CERTIFIED BY A REGISTERED ENGINEER, SHALL BE FORWARDED TO THE ARCHITECT WITHIN TWO (2) WEEKS AFTER THE TESTS ARE PERFORMED.

TESTS SHALL BE PERFORMED IN THE PRESENCE OF THE OWNER'S REPRESENTATIVE. "HI-POT" TEST VOLTAGES AND TIMES SHALL BE COORDINATED WITH AND DETERMINED BY THE OWNER'S REPRESENTATIVE WHEN ANY OTHER CABLE OR DEVICES, OTHER THAN THAT INSTALLED NEW BY ELECTRICAL CONTRACTOR UNDER HIS CONTRACT, IS TO BE INCLUDED IN THE TEST PROCEDURES. CONTRACTOR SHALL NOTIFY THE OWNER'S REPRESENTATIVE, IN WRITING, HIS INTENTIONS TO PERFORM THE HI-POTTING TEST, INCLUDING TIME AND DATE AND THE TESTING AGENCY.

IN GENERAL TESTS SHALL BE CONDUCTED AS FOLLOWS:

MAXIMUM D.C. VOLTAGES 52.8 KV.

BUILD-UP TIME TO TEST VOLTAGE - ONE (1) MINUTE IN 10 KV DC STEPS WITH RECORDED MILL-AMP READINGS AT 156, 30 AND 45 SECONDS.

HOLDING TIME AT TEST VOLTAGE - FIVE (5) MINUTES, WITH RECORDED MILL-AMP READING AT THE END OF EACH MINUTE.

"DECAY TIME" SHALL BE RECORDED WITH SHUT-OFF AT APPROXIMATELY 1-3 KV.

THE "HI-POT" TEST SHALL NOT BE MADE UNTO ANY PORTION OF AN

ENERGIZED DEVICE. SUFFICIENT TIME LAG SHALL BE ALLOWED IN THE INSTANT REQUEST FOR THE OWNER TO SET UP A DEFINITE PERIOD OF TESTING IF ANY PORTION OF THE OWNER'S DISTRIBUTION SYSTEM IS INVOLVED.

GROUNDING

THE NEUTRAL CONDUCTORS AND ALL OTHER EXPOSED NON-CURRENT CARRYING METAL PARTS AS REQUIRED BY CODE SHALL BE GROUNDED. GROUNDING BUSHING SHALL BE USED AS REQUIRED AND SHALL BE 0.2 INSULATED TYPE BL OR APPROVED EQUAL. NO GROUNDING SHALL BE MADE TO GAS PIPING. WHERE EQUIPMENT OR DEVICES ARE SERVED BY NON-METALLIC DUCTS, ENCLOSURES SHALL BE GROUNDED BY MEANS OF A CODE SIZE BARE OR GREEN INSULATED EQUIPMENT GROUND WIRE INSTALLED IN THE DUCT WITH THE CURRENT CARRYING CONDUCTORS AND BE BONDED SECURELY IN EACH CABINET TERMINATING THE GROUND WIRE. COPPER JUMPERS SHALL BRIDGE FLEXIBLE CONDUIT AND BE INSTALLED IN THE CONDUIT. ALL SERVICE GROUNDS SHALL BE IN ACCORDANCE WITH THE USER GROUND.

ALL EMT, FLEXIBLE CONDUIT, MC CABLE, OR PVC CONDUIT SHALL BE PROVIDED WITH AN INSULATED GREEN GROUND WIRE.

16700 COMMUNICATIONS

16740 TELEPHONE:

PROVIDE EMPTY CONDUIT OR DUCT WITH "JET-LINE" OR EQUAL POLYPROPYLENE PULL LINE AND TERMINAL MOUNTING BOARD AS SHOWN ON DRAWINGS.

USE LARGE RADIUS RIGID GALVANIZED STEEL CONDUIT FOR BENDS AND OFFSETS IN DUCT RUNS.

ALL CONDUIT RUNS TO TELEPHONE OUTLET BOXES SHALL BE A MINIMUM OF 3/4" AND HAVE A MAXIMUM OF TWO 90 DEGREE BENDS.

TELEPHONE TERMINAL BOARDS SHALL BE 3/4" FIR PLYWOOD, GRADE CC PLUS SIZE, AS INDICATED ON DRAWINGS. TELEPHONE TERMINAL CABINETS SHALL HAVE THE DOOR FASTENED TO THE TRIM WITH CONCEALED HINGES AND BE PROVIDED WITH FLUSH TYPE COMBINATION LATCH AND LOCK, KEYS TO MATCH LIGHTING PANELS, CABINETS AND TRIM SHALL BE FACTORY PAINTED WITH TWO FINISH COATS.

PROVIDE ALL NECESSARY MATERIAL AND LABOR REQUIRED BY THE TELEPHONE COMPANY FOR DELIVERING SERVICE TO THE TELEPHONE TERMINAL BOARD. ALL CONDUIT, TRENCHING AND BACKFILL SHALL BE PROVIDED BY THE ELECTRICAL CONTRACTOR IN ACCORDANCE WITH THE TELEPHONE COMPANY STANDARDS.

16800 DATA:

ALL CONDUIT RUNS TO DATA OUTLET BOXED SHALL BE A MINIMUM OF 3/4" AND HAVE A MAXIMUM OF TWO 90 DEGREE BENDS.

ALL DATA OUTLETS ARE TO HAVE WALL PLATES TO MATCH THE DEVICE PLATE.

GUARANTEE

GUARANTEE ALL MATERIAL, EQUIPMENT, AND WORKMANSHIP FOR ALL SECTIONS UNDER THIS DIVISION IN WRITING TO BE FREE FROM DEFECT OF MATERIAL AND WORKMANSHIP FOR ONE YEAR FROM THE DATE OF FINAL ACCEPTANCE. REPLACE WITHOUT CHARGE, ANY MATERIAL OR EQUIPMENT PROVED DEFECTIVE DURING THIS PERIOD. THE GUARANTEE SHALL INCLUDE PERFORMANCE OF THE EQUIPMENT UNDER ALL CONDITIONS OF LOAD, INSTALLING ANY ADDITIONAL ITEMS OF CONTROL AND/OR PROTECTIVE DEVICES AS REQUIRED.

GENERAL ELECTRICAL NOTES (NOTES APPLY WHETHER KEYED TO PLAN OR NOT)

1 LIGHTING

1a SEE ARCHITECTURAL PLANS AND REFLECTED CEILING PLAN FOR LOCATION OF ALL LIGHT FIXTURES, INCLUDING COVE AND MILLWORK LIGHTING. WHERE FIXTURE LOCATIONS NEED TO BE CHANGED, COORDINATE WITH ARCHITECT. AVOID ROLL-UP DOORS.

1b BEFORE ORDERING FIXTURES, FIELD VERIFY THAT FIXTURES WILL FIT IN AVAILABLE SPACE.

1c VERIFY LAMP TYPE / COLOR, NUMBER OF LAMPS PER FIXTURE, LENS TYPE, AND VOLTAGE BEFORE ORDERING NEW FIXTURES TO MATCH EXISTING.

2 EMERGENCY LIGHTING

2a UNLESS INDICATED OTHERWISE, FLOURESCENT FIXTURES INDICATED AS EMERGENCY LIGHTS SHALL HAVE A 1 LAMP EMERGENCY LIGHTING FLOURE

FINISH SCHEDULE

ID TAG	MATERIAL	MANUFACTURER	MODEL	REMARKS
ZONE 1 (BODY AND TOWER)				
1	CORRUGATED METAL	WESTERN STATES	WESTERN RIB 7.2 PANELS 24 GA	PREFINISHED COLOR SILVER ZINC MATTE FINISH
2	CORRUGATED METAL	WESTERN STATES	WESTERN WAVE 16.0 PANELS 24 GA	PREFINISHED MATTE CHARCOAL GRAY
3	LAP SIDING	JAMES HARDIE	WOODTONE RUSTIC SERIES 9 1/4" WIDE	PRE-FINISHED SAND CASTLE
FLASHING, COLUMNS AND CANOPY				
4	PAINTED STEEL	SHERWIN WILLIAMS	COLOR TO MATCH DEVELOPMENT METAL AWNINGS	SW4026 SLATE GRAY
5	PAINTED STEEL	WESTERN STATES	PREFINISHED PARAPET CAP	COLOR SILVER ZINC MATTE
6	PAINTED STEEL	SHERWIN WILLIAMS	PREFINISHED PARAPET CAP	COLOR MATTE CHARCOAL GRAY
7	MASONRY	ANGELUS BLOCK	SMOOTH FACE	COLOR ONXY TO MATCH APPROVED DEVELOPMENT PALETTE

KEY NOTES

1. FINISH EXTERIOR MATERIAL. INSTALL PER MANUFACTURER'S SPECIFICATION.
2. STEEL CANOPY. REFER TO STRUCTURAL DRAWINGS FOR ADDITIONAL INFORMATION.
3. WINDOW. REFER TO WINDOW SCHEDULE FOR ADDITIONAL INFORMATION.
4. DOOR. REFER TO DOOR SCHEDULE FOR ADDITIONAL INFORMATION.
5. SIGNAGE. UNDER SEPARATED SUBMITTAL.
6. 48" W X 12" D SERVICE COUNTER AR 34" AFF. DOWNSPOUT DAYLIGHT.
7. EXTERIOR LIGHTING AT 9"-2" AFF. TYP OF (7). CAP FLASHING.
8. AWNING CORRUGATED METAL PANEL.
9. RTU - SEE MECHANICAL PLANS FOR ADDITIONAL INFORMATION.
10. SCREENED ROOFTOP MECHANICAL.
11. GLAZING AT DOOR AND THIS ENTIRE STOREFRONT TO BE DARK TINTED GLASS.
12. SCREEN WALL.
13. WALL MOUNTED ELECTRIC METER AND DISCONNECT TO BE PAINTED TO MATCH SURROUNDING WALL COLOR.

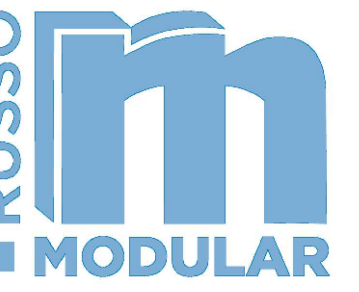

3836 W BUCKEYE RD
BUILDING C
PHOENIX, AZ 85009
623-328-5196

THIS DRAWING IS AN INSTRUMENT OF SERVICE AND AS SUCH SHALL REMAIN THE PROPERTY OF RUSSO LLC. UNAUTHORIZED USE OF REPRODUCTION WITHOUT PERMISSION IS PROHIBITED.

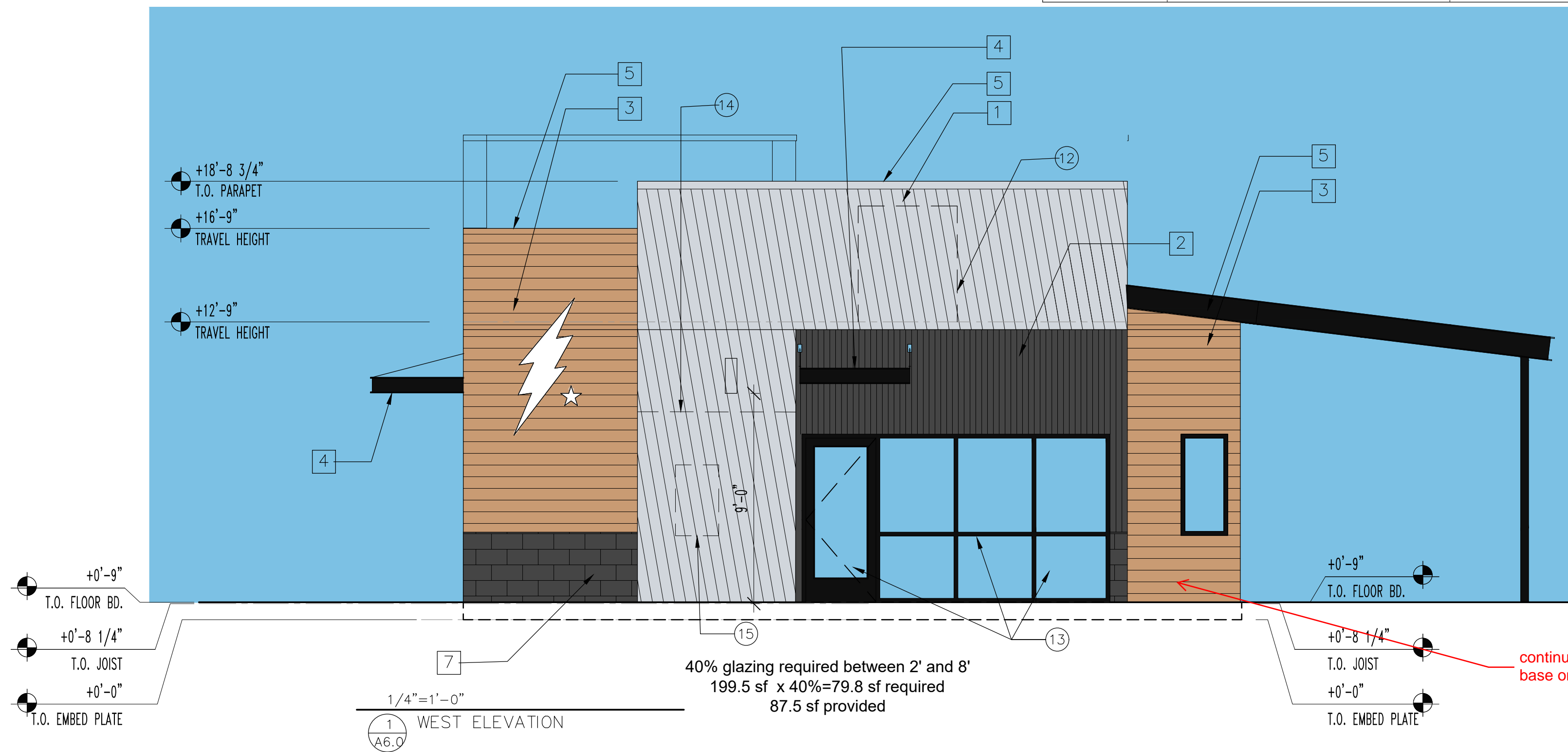
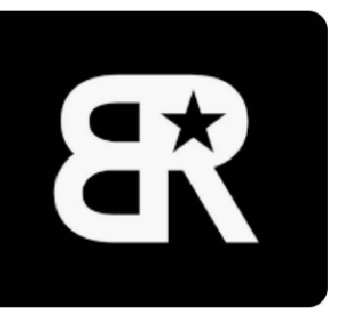

SIGNS WILL BE REVIEWED FOR COMPLIANCE AND APPROVED THROUGH THE SIGNAGE PERMIT PROCESS

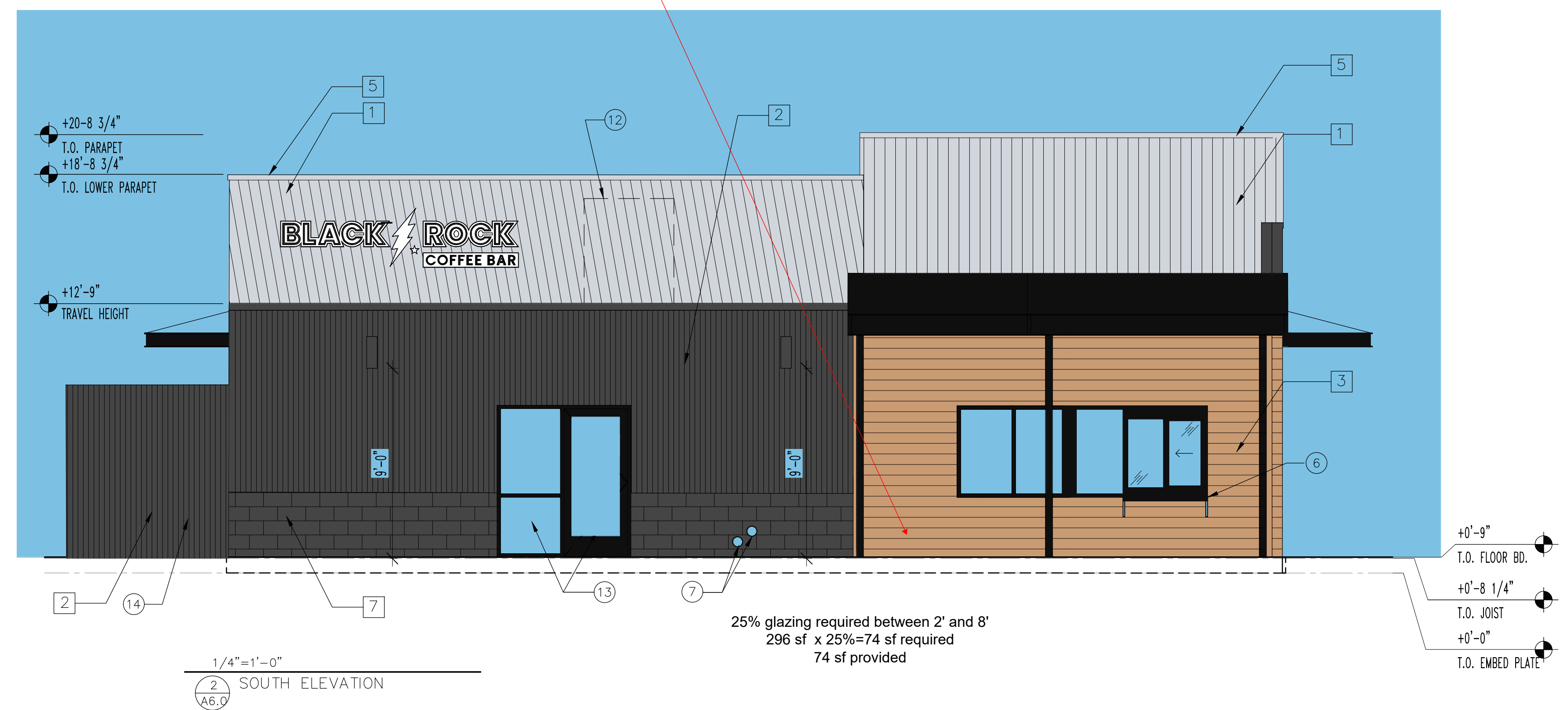

BLACK ROCK COFFEE
MODULAR BUILDING



NOT FOR
CONSTRUCTION

CONTROL # 001
JOB NUMBER:
DATE: 2-4-25
CONTENTS:
EXTERIOR ELEVATIONS

A6.0

FINISH SCHEDULE

ID TAG	MATERIAL	MANUFACTURER	MODEL	REMARKS
ZONE 1 (BODY AND TOWER)				
1	CORRUGATED METAL	WESTERN STATES	WESTERN RIB 7.2 PANELS 24 GA	PREFINISHED COLOR SILVER ZINC MATTE FINISH
2	CORRUGATED METAL	WESTERN STATES	WESTERN WAVE 16.0 PANELS 24 GA	PREFINISHED MATTE CHARCOAL GRAY
3	LAP SIDING	JAMES HARDIE	WOODTONE RUSTIC SERIES 9 1/4" WIDE	PRE-FINISHED SAND CASTLE
FLASHING, COLUMNS AND CANOPY				
4	PAINTED STEEL	SHERWIN WILLIAMS	COLOR TO MATCH DEVELOPMENT METAL AWNINGS	SW4026 SLATE GRAY
5	PAINTED STEEL	WESTERN STATES	PREFINISHED PARAPET CAP	COLOR SILVER ZINC MATTE
6	PAINTED STEEL	SHERWIN WILLIAMS	PREFINISHED PARAPET CAP	COLOR MATTE CHARCOAL GRAY
7	MASONRY	ANGELUS BLOCK	SMOOTH FACE	COLOR ONXY TO MATCH APPROVED DEVELOPMENT PALETTE

KEY NOTES

1. FINISH EXTERIOR MATERIAL. INSTALL PER MANUFACTURER'S SPECIFICATION.
2. STEEL CANOPY. REFER TO STRUCTURAL DRAWINGS FOR ADDITIONAL INFORMATION.
3. WINDOW. REFER TO WINDOW SCHEDULE FOR ADDITIONAL INFORMATION.
4. DOOR. REFER TO DOOR SCHEDULE FOR ADDITIONAL INFORMATION.
5. SIGNAGE. UNDER SEPARATED SUBMITTAL.
6. 48" W X 12" D SERVICE COUNTER AR 34" AFF.
7. DOWNSPOUT DAYLIGHT.
8. EXTERIOR LIGHTING AT 9"-2" AFF. TYP OF (7), CAP FLASHING.
9. AWNING CORRUGATED METAL PANEL.
10. RTU - SEE MECHANICAL PLANS FOR ADDITIONAL INFORMATION.
11. SCREENED ROOFTOP MECHANICAL ELECTRICAL METER AND DISCONNECT.
12. SCREEN WALL.

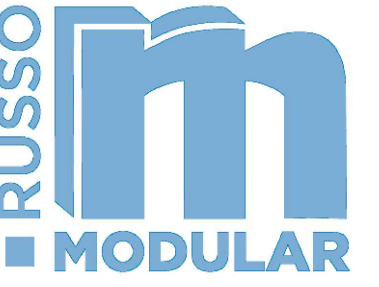

3836 W BUCKEYE RD
BUILDING C
PHOENIX, AZ 85009
623-328-5196

THIS DRAWING IS AN INSTRUMENT OF SERVICE AND AS SUCH SHALL REMAIN THE PROPERTY OF RUSSO LLC. UNAUTHORIZED USE OF REPRODUCTION WITHOUT PERMISSION IS PROHIBITED.

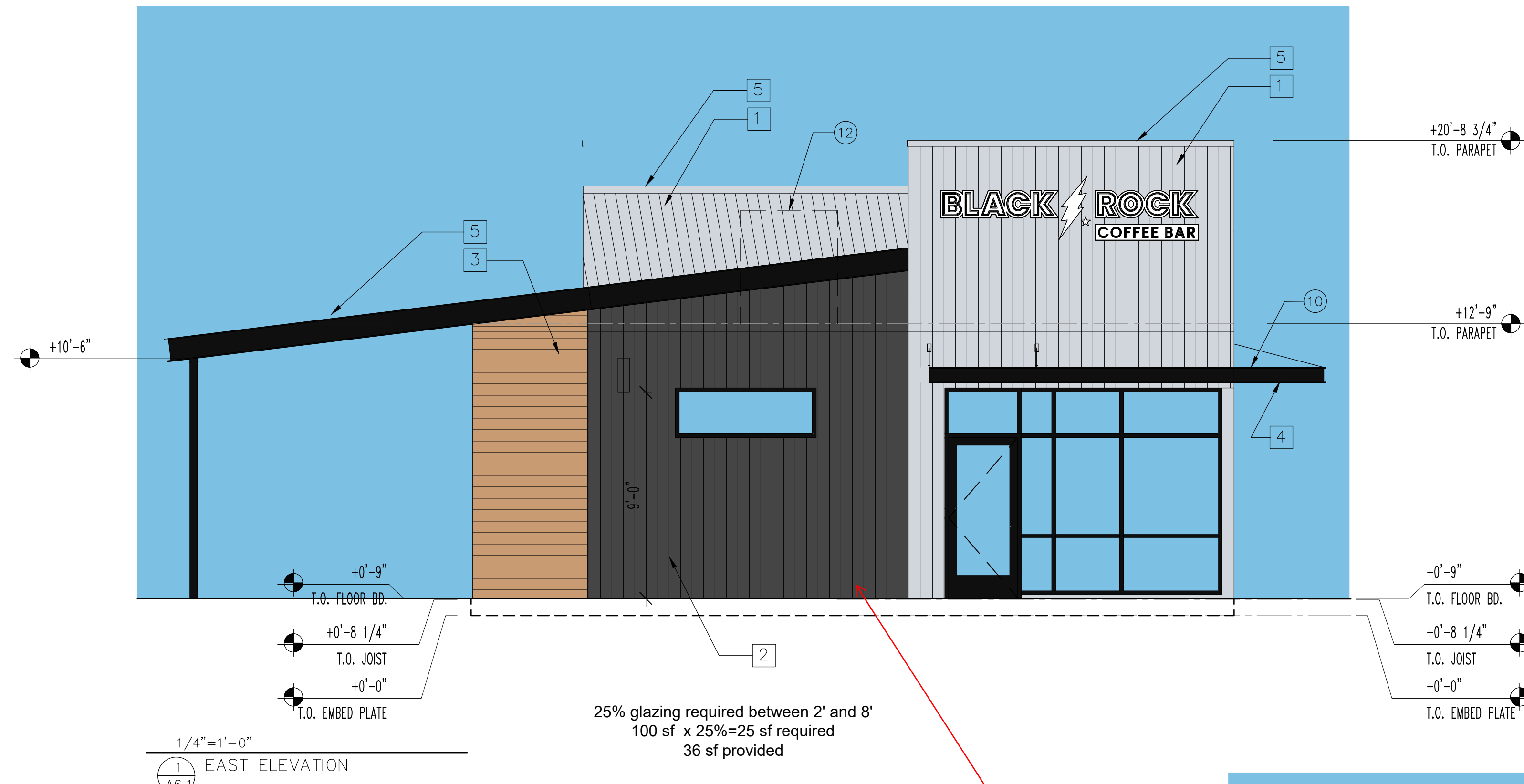

SIGNS WILL BE REVIEWED FOR COMPLIANCE AND APPROVED THROUGH THE SIGNAGE PERMIT PROCESS

#13 not shown on these elevations

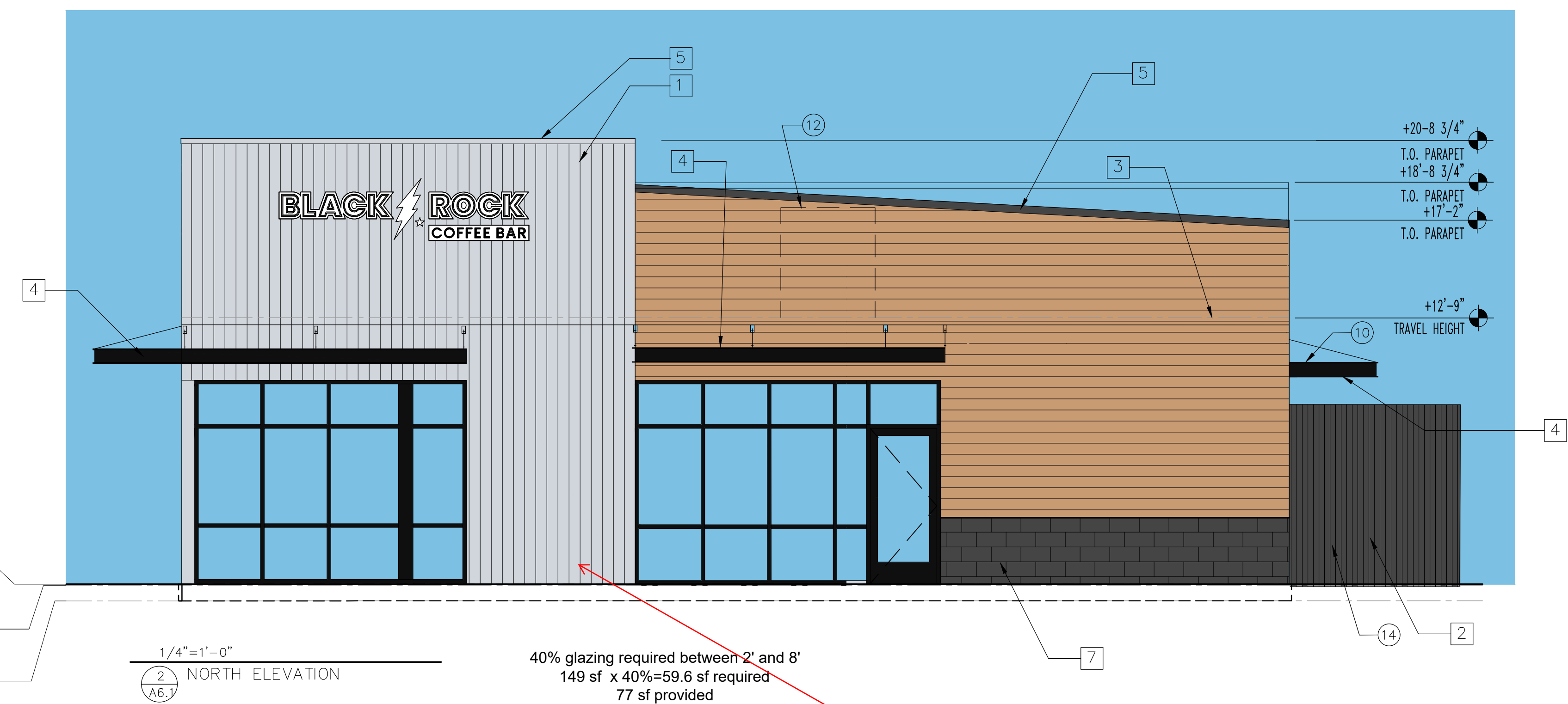

BLACK ROCK COFFEE
MODULAR BUILDING



NOT FOR
CONSTRUCTION

CONTROL # 001
JOB NUMBER:
DATE: 2-4-25
CONTENTS:
EXTERIOR ELEVATIONS

A6.1