

SOUTH METRO FIRE RESCUE

FIRE MARSHAL'S OFFICE



Elizabeth Steward
Town of Parker
20120 E. Mainstreet
Parker, CO 80138
303.805.3338

Project Name: Commercial building (northeast of Hess Road and Chambers Road)
Project File #: **SP25-021**
S Metro Review #: REFSP25-00242

Review date: 10-9-25

Plan reviewer: Scott Stene
720-989-2249
Scott.stene@southmetro.org

Project Summary: Proposing a 15,877 square foot commercial building and containing up to 7 commercial tenants and 54 vehicle parking spaces.

Code Reference: 2021 International Fire Code (IFC), 2021 International Building Code

South Metro Fire Rescue (SMFR) has reviewed the above project and has **conditionally approved** the plans based on the following comments that must be resolved prior issuance of any permits. Applicants and Contractors are encouraged to contact SMFR regarding the applicable permit requirements for the proposed project.

COMMENTS:

1. **A separate commercial water distribution (CWDS) permit is required from SMFR. Locate fire hydrant on the southwest corner of the site just outside the fire riser room. *Noted.***
2. **Road grading shall not exceed 6%. *The site grading complies with this requirement.***
3. **Provide updated auto-turn analysis and note specs on sheet. *Updated Auto-turn included with resubmittal.***
4. **Fire riser room shall be located on the southwest corner of the building with exterior access. *Provided.***
5. **Fire department access roads and dead-end access road turnarounds shall be installed in accordance with the 2021 IFC Appendix D. *Provided. See dimensions on site plan.***

Fire Flow per Appendix B

Construction Type	Building Area (SF)	Fire Flow (GPM)	Sprinkler System (Type)	Reduced Fire Flow
V-B	15,877	3,500	NFPA 13	1,750

SOUTH METRO FIRE RESCUE

FIRE MARSHAL'S OFFICE



FIRE ACCESS ROAD DESIGN CRITERIA



BUILDING exterior walls (and any portion thereof) of any buildings that are more than 150 feet from the curb line of a public street shall be served by a Fire Apparatus Access Road which shall be unobstructed. This distance is measured by an approved route around the exterior of the building or facility. Additional allowances may be made for some sprinkler protected structures. Alternate access arrangements may be accepted based on site conditions and building fire protection features.

Due to the possibility of heavy vehicle traffic, residential and commercial collector and arterial roads may not be considered adequate for fire suppression operations; no credit for access to perimeter of buildings shall be given from collectors or arterials, unless specifically approved.

Sites not be capable of meeting these requirements and any alternative means must be evaluated and approved by the Fire Marshal.

FIRE APPARATUS ACCESS ROADS shall be of an all-weather surface capable of supporting the imposed loads of fire apparatus. Maximum grade on site shall not exceed six percent (6%). Roads shall be asphalt or concrete. Other surfaces may be accepted on a case by case basis.

The minimum unobstructed width of the fire apparatus access road shall be 20 feet. In order to maintain the minimum width and prevent obstructions such as parking of vehicles fire lane signs shall be installed in an approved manner. A minimum vertical clearance of 13 feet, 6 inches shall be maintained for the entire required width of the access road.

SOUTH METRO FIRE RESCUE FIRE MARSHAL'S OFFICE



Any dead-end access road over 150 feet long shall be provided with an approved turnaround that may be a circle, tee, hammerhead, or other functional approved design.

VEHICLE SPECIFICATIONS are provided for the largest apparatus in use by South Metro Fire Rescue. Fire Apparatus Access Roads shall be capable of accommodating this apparatus.

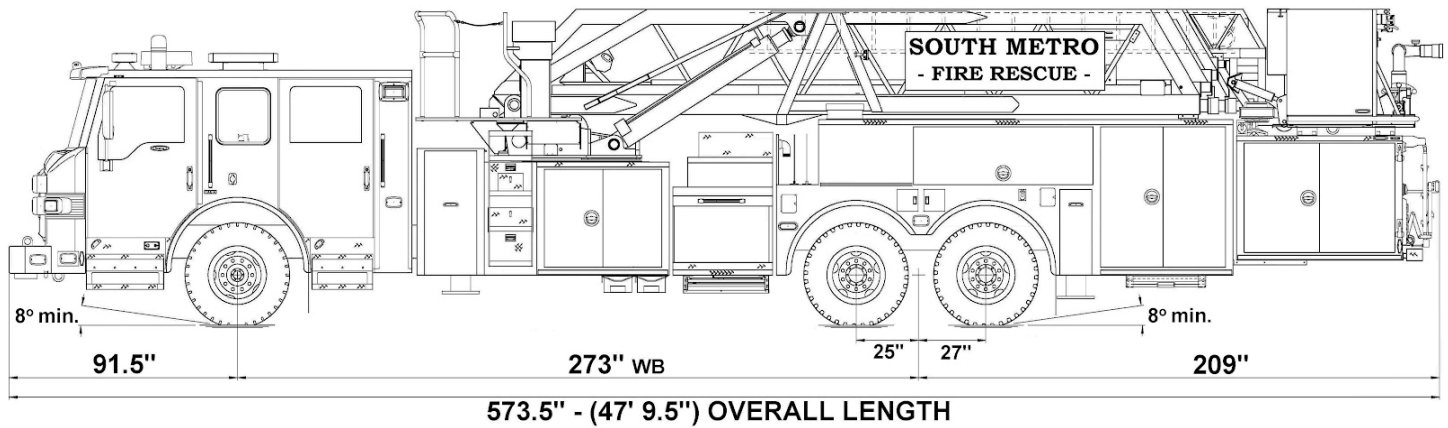

SOUTH METRO FIRE RESCUE FIRE MARSHAL'S OFFICE

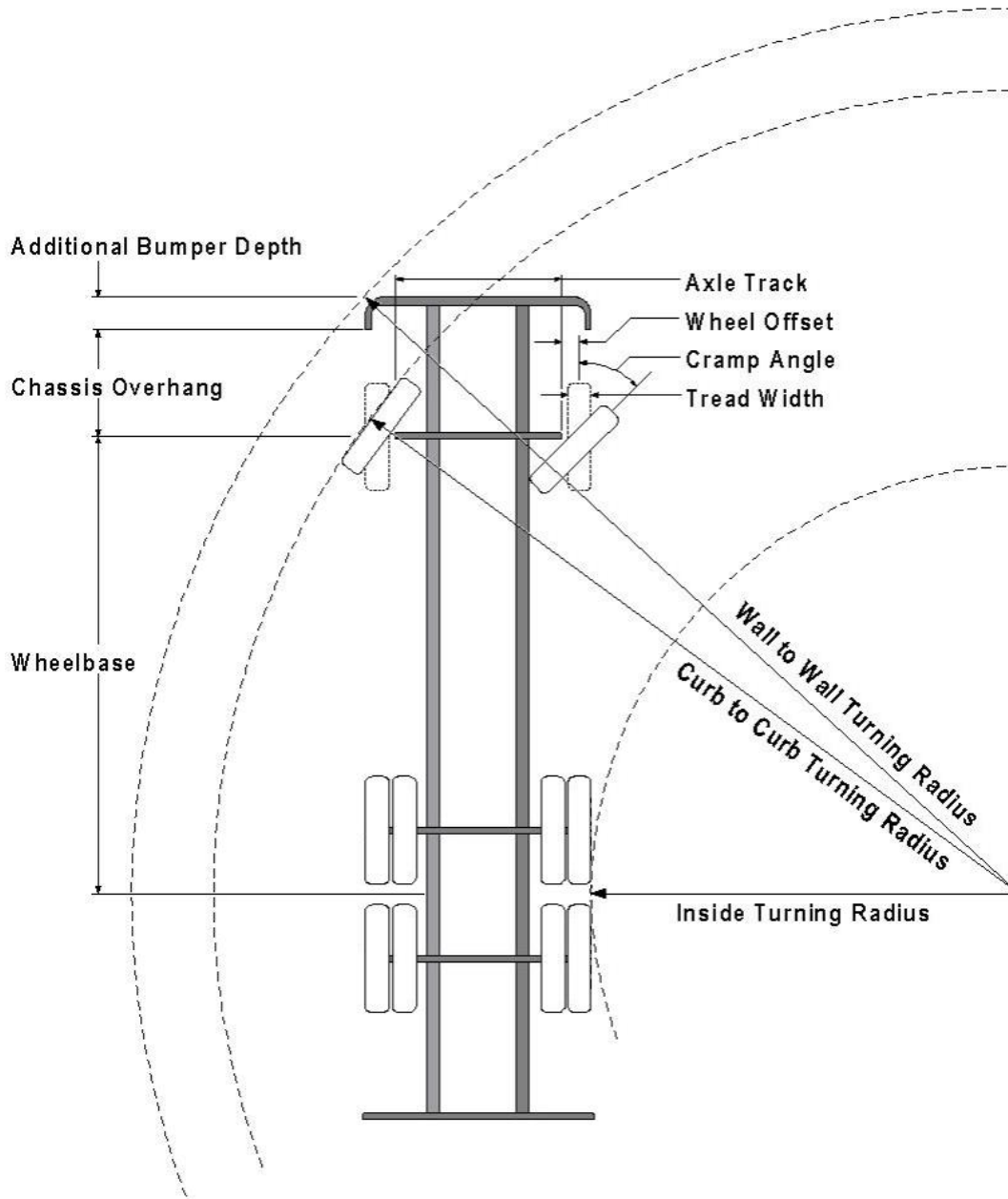

Vehicle Specifications

Length: 47' 9.5"

Width: 8' 5" - (10' 1" mirror to mirror)

Height: 10' 9"

Wheelbase: 273 in.

SOUTH METRO FIRE RESCUE

FIRE MARSHAL'S OFFICE



Design load: 80,000 pounds

Inside Cramp Angle: 40°

Axle Track: 83"

Wheel Offset: 5.3"

Tread Width: 13.5"

Turning Radii:

Inside Turn: 26 ft. 1 in.

Curb to curb: 41 ft. 11 in.

Wall to wall: 46 ft. 8 in.

Where objects are present adjacent to the fire apparatus access road, particularly on turns and turn arounds which require backing, a reasonable safety margin shall be provided to prevent potential damage to the property and to the fire apparatus.

PRIVATE ROADS that provide access to more than two dwellings or one or more commercial buildings shall be constructed to meet the roadway standards approved by the South Metro Fire Rescue Authority for fire apparatus access. Private roads that do not meet the roadway standard may be accepted provided that alternative methods and materials are incorporated into the subdivision that address the fire and life safety of the citizens.