

COMPARK VILLAGE SOUTH FILING NO. 2 & COMPARK VILLAGE SOUTH FILING NO. 2 - AMENDMENT NO. 1 FINAL LANDSCAPE PLAN

A PARCEL OF LAND LOCATED IN THE SOUTH HALF OF SECTION 6, TOWNSHIP 6 SOUTH RANGE 66 WEST OF THE SIXTH PRINCIPAL MERIDIAN,
TOWN OF PARKER, COUNTY OF DOUGLAS, STATE OF COLORADO
PLANNING AREA 17 & 18
32.86 ACRES, 192 RESIDENTIAL UNITS, 20 TRACTS

Vicinity Map

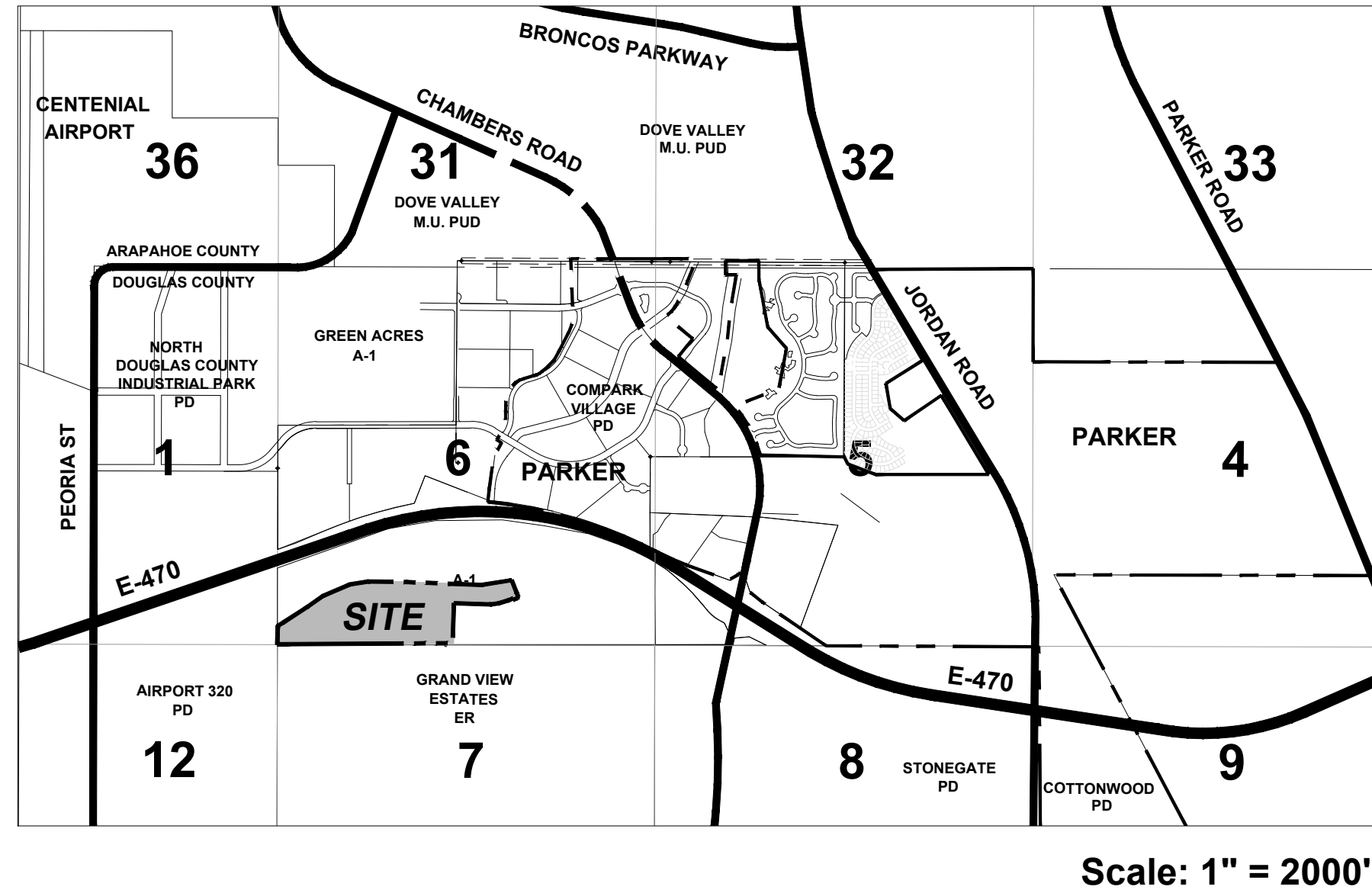

SITE DATA:

LOCATION: SOUTHWEST OF INTERSECTION OF S. CHAMBERS ROAD AND E-470;
PA-17 AND 18 IN THE COMPARK VILLAGE PD FOURTH AMENDMENT

AREA: 32.859 ACRES

ZONING:
PLANNED DEVELOPMENT

NOTES:

1. NO HISTORICAL OR ARCHAEOLOGICAL FEATURES HAVE BEEN IDENTIFIED ON THE SITE
2. NO WILDLIFE HABITAT AREAS HAVE BEEN IDENTIFIED ON THE SITE

COMPARK SOUTH - LEGAL DESCRIPTION

TRACT H, COMPARK VILLAGE SOUTH ALTA DESCRIPTION
PART OF LOTS 21, 22, AND 23, GREEN ACRES SUBDIVISION RECORDED IN BOOK 1152 AT PAGE 883, AT RECEPTION NO. 105760 OF THE RECORDS OF THE DOUGLAS COUNTY CLERK AND RECORDER TOGETHER WITH PART OF THE SOUTH HALF OF SECTION 6, TOWNSHIP 6 SOUTH, RANGE 66 WEST OF THE SIXTH PRINCIPAL MERIDIAN, COUNTY OF DOUGLAS, STATE OF COLORADO, BEING MORE PARTICULARLY DESCRIBED AS FOLLOWS

COMMENCING AT THE SOUTHWEST CORNER OF SAID SECTION 6 AND CONSIDERING THE WEST LINE OF THE SOUTHWEST QUARTER OF SAID SECTION 6 TO BEAR NORTH 00°30'14" WEST, AND MONUMENTED AS SHOWN HEREON, WITH ALL BEARINGS CONTAINED HEREIN RELATIVE THERETO

THENCE NORTH 87°55'04" EAST, ALONG THE SOUTH LINE OF THE SOUTHWEST QUARTER OF THE SOUTHWEST QUARTER OF SAID SECTION 6, A DISTANCE OF 487.85 FEET TO THE POINT OF BEGINNING

THENCE NORTH 01°13'56" WEST, A DISTANCE OF 190.72 FEET;
THENCE NORTH 49°15'47" WEST, A DISTANCE OF 3.50 FEET TO A POINT OF CURVATURE

THENCE ALONG THE ARC OF A TANGENT CURVE TO THE RIGHT HAVING A CENTRAL ANGLE OF 148°02'43", A RADIUS OF 52.00 FEET, AN ARC LENGTH OF 134.36 FEET, THE CHORD OF WHICH BEARS NORTH 24°45'34" EAST, A DISTANCE OF 99.98 FEET TO A NON-TANGENT LINE

THENCE NORTH 46°57'03" WEST, A DISTANCE OF 180.84 FEET;
THENCE NORTH 52°39'42" EAST, A DISTANCE OF 226.57 FEET TO A POINT OF CURVATURE

THENCE ALONG THE ARC OF A TANGENT CURVE TO THE RIGHT HAVING A CENTRAL ANGLE OF 37°49'41", A RADIUS OF 1,445.00 FEET, AN ARC LENGTH OF 954.03 FEET, THE CHORD OF WHICH BEARS NORTH 71°34'32" EAST, A DISTANCE OF 936.79 FEET TO A POINT OF TANGENCY

THENCE SOUTH 89°30'37" EAST, A DISTANCE OF 1,237.63 FEET TO A POINT OF CURVATURE

THENCE ALONG THE ARC OF A TANGENT CURVE TO THE LEFT HAVING A CENTRAL ANGLE OF 26°11'10", A RADIUS OF 1,130.00 FEET, AN ARC LENGTH OF 516.45 FEET, THE CHORD OF WHICH BEARS NORTH 77°23'48" EAST, A DISTANCE OF 511.96 FEET TO A NON-TANGENT LINE

THENCE SOUTH 24°18'07" EAST, A DISTANCE OF 164.92 FEET;
THENCE NORTH 65°41'53" EAST, A DISTANCE OF 19.50 FEET;
THENCE SOUTH 24°18'07" EAST, A DISTANCE OF 55.00 FEET;
THENCE SOUTH 65°41'53" WEST, A DISTANCE OF 19.50 FEET;
THENCE SOUTH 24°18'07" EAST, A DISTANCE OF 19.50 FEET;
THENCE SOUTH 65°41'53" WEST, A DISTANCE OF 55.00 FEET;
THENCE NORTH 24°18'07" WEST, A DISTANCE OF 19.50 FEET;
THENCE SOUTH 65°41'53" WEST, A DISTANCE OF 68.71 FEET TO A POINT OF CURVATURE

THENCE ALONG THE ARC OF A TANGENT CURVE TO THE RIGHT HAVING A CENTRAL ANGLE OF 24°47'30", A RADIUS OF 777.50 FEET, AN ARC LENGTH OF 336.42 FEET, THE CHORD OF WHICH BEARS SOUTH 78°05'38" WEST, A DISTANCE OF 333.80 FEET TO A POINT OF TANGENCY

THENCE NORTH 89°30'37" WEST, A DISTANCE OF 592.46 FEET;
THENCE SOUTH 00°29'23" WEST, A DISTANCE OF 220.00 FEET;
THENCE SOUTH 89°30'37" EAST, A DISTANCE OF 19.50 FEET;
THENCE SOUTH 00°29'23" WEST, A DISTANCE OF 55.00 FEET;
THENCE SOUTH 89°30'37" EAST, A DISTANCE OF 175.18 FEET;
THENCE SOUTH 00°16'48" WEST, A DISTANCE OF 177.64 FEET;
THENCE SOUTH 70°12'58" WEST, A DISTANCE OF 7.84 FEET;
THENCE SOUTH 87°20'33" WEST, A DISTANCE OF 226.67 FEET;
THENCE NORTH 78°16'52" WEST, A DISTANCE OF 117.49 FEET;
THENCE SOUTH 85°55'18" WEST, A DISTANCE OF 277.28 FEET;
THENCE SOUTH 78°47'52" WEST, A DISTANCE OF 224.67 FEET;
THENCE SOUTH 87°55'29" WEST, A DISTANCE OF 193.89 FEET;
THENCE SOUTH 87°30'33" WEST, A DISTANCE OF 509.04 FEET;
THENCE SOUTH 87°51'03" WEST, A DISTANCE OF 172.31 FEET;
THENCE SOUTH 78°58'28" WEST, A DISTANCE OF 123.15 FEET TO A POINT OF CURVATURE

THENCE ALONG THE ARC OF A TANGENT CURVE TO THE LEFT HAVING A CENTRAL ANGLE OF 81°03'24", A RADIUS OF 40.00 FEET, AN ARC LENGTH OF 56.59 FEET, THE CHORD OF WHICH BEARS SOUTH 38°26'46" WEST, A DISTANCE OF 51.99 FEET TO A POINT OF TANGENCY

THENCE SOUTH 02°04'56" EAST, A DISTANCE OF 16.72 FEET TO SAID SOUTH LINE OF THE SOUTHWEST QUARTER OF THE SOUTHWEST QUARTER OF SECTION 6

THENCE SOUTH 87°55'04" WEST, A DISTANCE OF 86.41 FEET ALONG SAID SOUTH LINE TO THE POINT OF BEGINNING.

CONTAINING A CALCULATED AREA OF 1,431,559 SQUARE FEET OR 32.8641 ACRES, MORE OR LESS.

SHEET INDEX

L1	COVER SHEET
L2	FINAL LANDSCAPE PLAN
L3	FINAL LANDSCAPE PLAN
L4	FINAL LANDSCAPE PLAN
L5	MUSE LANDSCAPE TEMPLATE
L6	MUSE LANDSCAPE TEMPLATE
L7	LANDSCAPE SCHEDULE AND NOTES
L8	LANDSCAPE DETAILS
L9	LANDSCAPE DETAILS
L10	LANDSCAPE DETAILS
L11	FENCING PLAN
L12	FENCING PLAN
L13	FENCING DETAILS
L14	LANDSCAPE SECTIONS
0	OVERALL IRRIGATION AREA
1	IRRIGATION SCHEDULE AND NOTES
2-11	IRRIGATION PLANS
12-15	IRRIGATION DETAILS
16	IRRIGATION CHARTS

COMPARK VILLAGE SOUTH FILING NO. 2 & COMPARK VILLAGE SOUTH FILING NO. 2 - AMENDMENT NO. 1 FINAL LANDSCAPE PLAN - COVER SHEET

OWNER
470 Compark, LLC
290 Fillmore St., Suite 2
Denver, CO 80206

LANDSCAPE ARCHITECT
Plan West, Inc.
767 Santa Fe Drive
Denver, CO 80204
(303) 741-1411

Town of Parker
Colorado
job no. 2015-20
date 11-22-2016
revisions 07-05-2017

ENGINEER
Manhard Consulting
8008 E. Arapahoe Ct. Suite 110
Centennial 80112
(303) 531-3213

sheet **L1** of **L14**



THE REPRODUCTION OF ANY INFORMATION GENERATED BY ARCHITECTS, ENGINEERS OR OTHER CONSULTANTS ON THESE DRAWINGS IS FOR THE EXPRESS PURPOSE OF COORDINATION AND EASE OF REFERENCE ONLY. INCLUSION OF SAID INFORMATION ON THESE DRAWINGS DOES NOT CONSTITUTE A REPRESENTATION BY PLAN WEST AS TO THE SUFFICIENCY OR ACCURACY OF SAID INFORMATION.

PLANNING | SITE DESIGN | LANDSCAPE ARCHITECTURE | ENTITLEMENTS
767 Santa Fe Drive
Denver, Colorado, 80204
303-741-1411

COMPARK VILLAGE SOUTH FILING NO. 2 & COMPARK VILLAGE SOUTH FILING NO. 2 - AMENDMENT NO. 1 FINAL LANDSCAPE PLAN

A PARCEL OF LAND LOCATED IN THE SOUTH HALF OF SECTION 6, TOWNSHIP 6 SOUTH RANGE 66 WEST OF THE SIXTH PRINCIPAL MERIDIAN,
TOWN OF PARKER, COUNTY OF DOUGLAS, STATE OF COLORADO
PLANNING AREA 17 & 18
32.86 ACRES, 192 RESIDENTIAL UNITS, 20 TRACTS

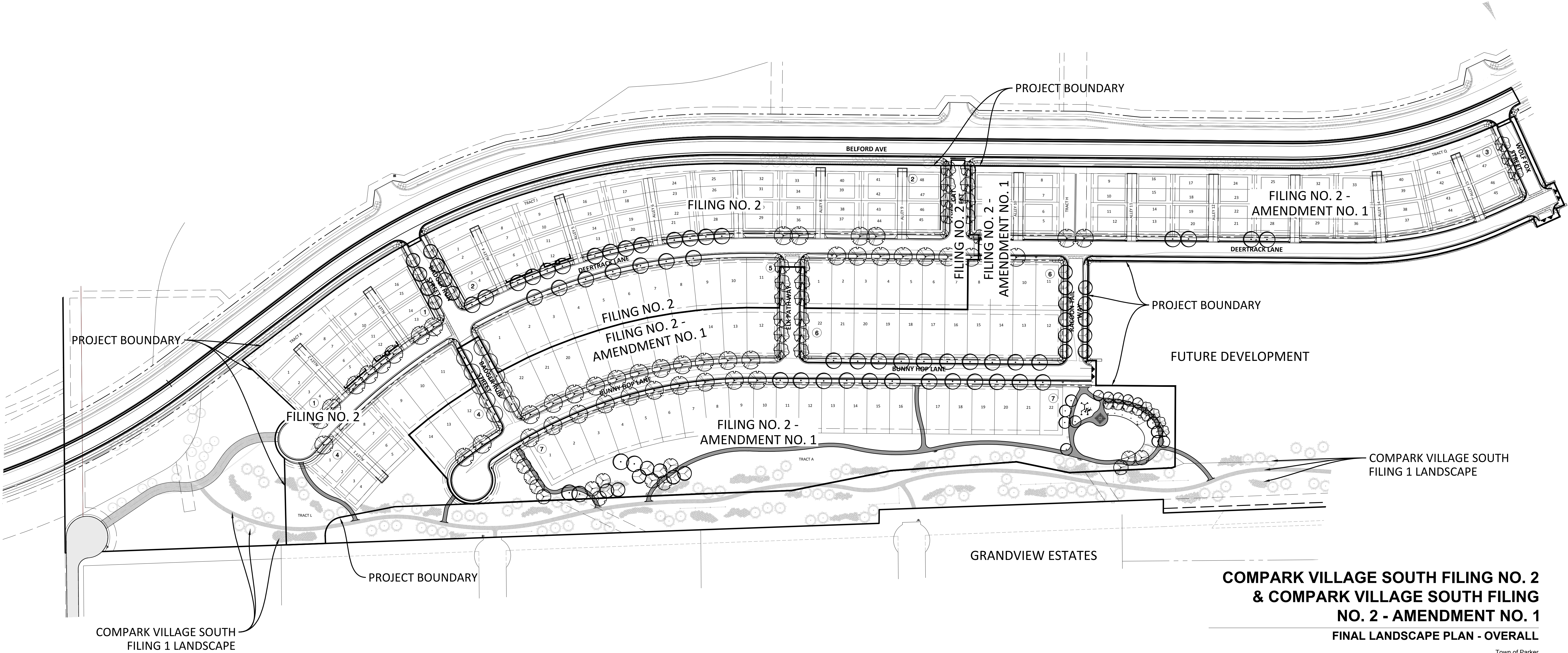

COMPARK VILLAGE SOUTH FILING NO. 2 & COMPARK VILLAGE SOUTH FILING NO. 2 - AMENDMENT NO. 1 FINAL LANDSCAPE PLAN - OVERALL

<p>OWNER 470 Compark, LLC 290 Fillmore St., Suite 2 Denver, CO 80206</p>	<p>LANDSCAPE ARCHITECT Plan West, Inc. 767 Santa Fe Drive Denver, CO 80204 (303) 741-1411</p>	<p style="text-align: right;">Town of Parker Colorado</p> <p>job no. 2015-20 date 11-22-2016 revisions 07-05-2017</p>
---	--	---

sheet L2 of L14

ENGINEER
Manhard Consulting
8008 E. Arapahoe Ct. Suite 110
Centennial 80112
(303) 531-3213

Scale 1" = 100'

PLANWEST

THE REPRODUCTION OF ANY INFORMATION GENERATED BY ARCHITECTS, ENGINEERS OR OTHER CONSULTANTS ON THESE DRAWINGS IS FOR THE EXPRESS PURPOSE OF COORDINATION AND AS A REFERENCE ONLY. INCLUSION OF SAID INFORMATION ON THESE DRAWINGS DOES NOT CONSTITUTE A REPRESENTATION BY PLAN WEST AS TO THE SUFFICIENCY OR ACCURACY OF SAID INFORMATION.

North
PLANNING | SITE DESIGN | LANDSCAPE ARCHITECTURE | ENTITLEMENTS
Denver, Colorado, 80204
303-741-1411

COMPARK VILLAGE SOUTH FILING NO. 2 & COMPARK VILLAGE SOUTH FILING NO. 2 - AMENDMENT NO. 1 FINAL LANDSCAPE PLAN

A PARCEL OF LAND LOCATED IN THE SOUTH HALF OF SECTION 6, TOWNSHIP 6 SOUTH RANGE 66 WEST OF THE SIXTH PRINCIPAL MERIDIAN,
TOWN OF PARKER, COUNTY OF DOUGLAS, STATE OF COLORADO
PLANNING AREA 17 & 18

32.86 ACRES, 192 RESIDENTIAL UNITS, 20 TRACTS

STREET TREE SYMBOL LEGEND

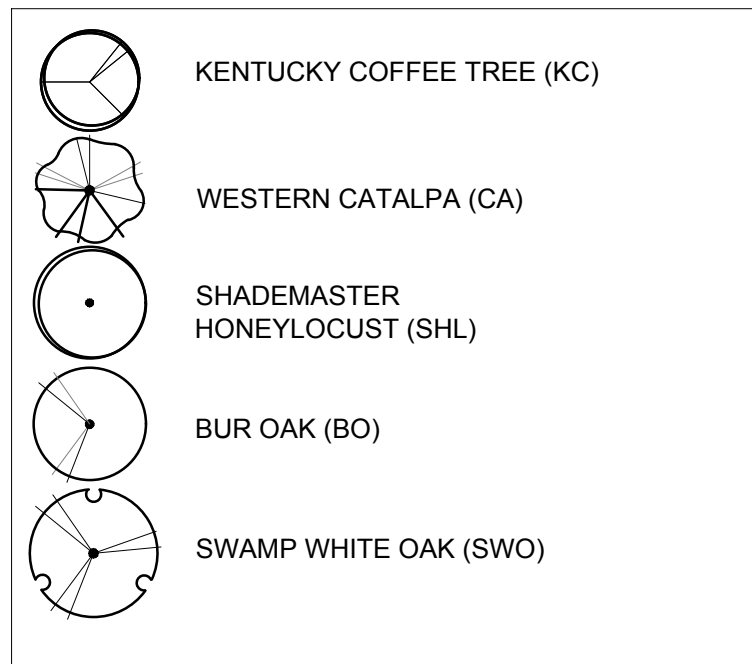

GROUND COVER LEGEND

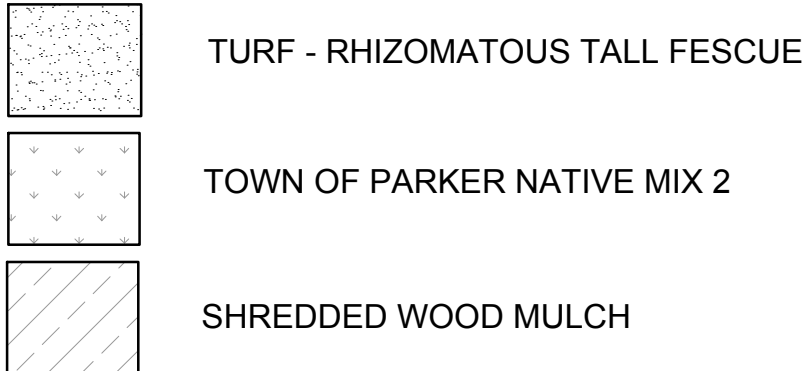

NOTE: SEE SHEET 5 AND SHEET 6 FOR MUSE LANDSCAPE TEMPLATE A AND B, TO BE DETERMINED BY BUILDER.

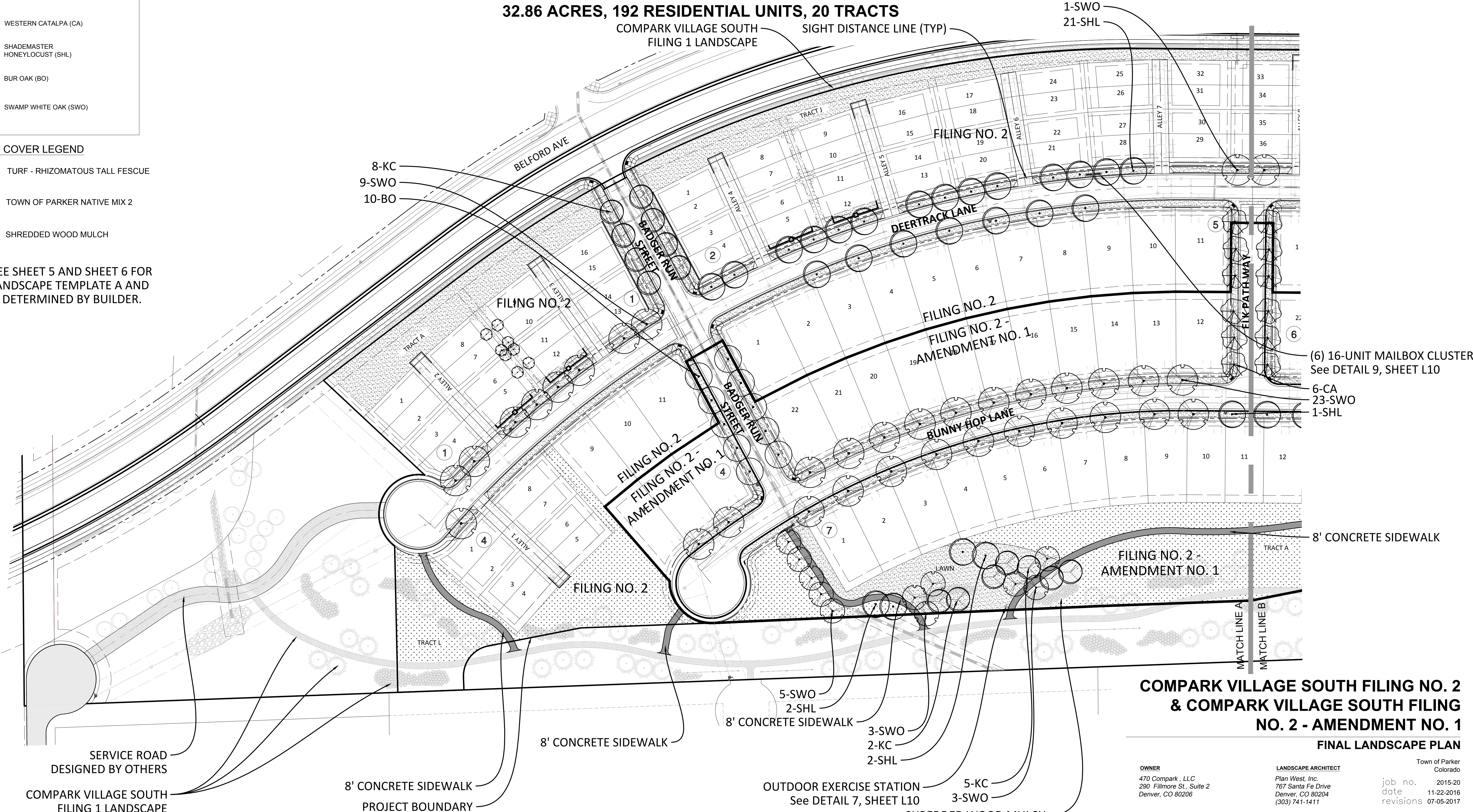

**COMPARK VILLAGE SOUTH FILING NO. 2
& COMPARK VILLAGE SOUTH FILING
NO. 2 - AMENDMENT NO. 1
FINAL LANDSCAPE PLAN**

<p>OWNER 470 Compark, LLC 290 Fillmore St., Suite 2 Denver, CO 80206</p>	<p>LANDSCAPE ARCHITECT Plan West, Inc. 767 Santa Fe Drive Denver, CO 80204 (303) 741-1411</p>
<p>Town of Parker Colorado job no. 2015-20 date 11-22-2016 revisions 07-05-2017</p>	

sheet L3 of L14

ENGINEER
Manhard Consulting
8008 E. Arapahoe Ct. Suite 110
Centennial CO 80112
(303) 531-3213

Scale 1" = 60'

North

PLANWEST
767 Santa Fe Drive
Denver, Colorado, 80204
303-741-1411

THE REPRODUCTION OF ANY INFORMATION GENERATED BY ARCHITECTS, ENGINEERS OR OTHER CONSULTANTS ON THESE DRAWINGS IS FOR THE EXPRESS PURPOSE OF COORDINATION AND AS A REFERENCE ONLY. INCLUSION OF SAID INFORMATION ON THESE DRAWINGS DOES NOT CONSTITUTE A REPRESENTATION BY PLAN WEST AS TO THE SUFFICIENCY OR ACCURACY OF SAID INFORMATION.

COMPARK VILLAGE SOUTH FILING NO. 2 & COMPARK VILLAGE SOUTH FILING NO. 2 - AMENDMENT NO. 1 FINAL LANDSCAPE PLAN

A PARCEL OF LAND LOCATED IN THE SOUTH HALF OF SECTION 6, TOWNSHIP 6 SOUTH RANGE 66 WEST OF THE SIXTH PRINCIPAL MERIDIAN,
TOWN OF PARKER, COUNTY OF DOUGLAS, STATE OF COLORADO
PLANNING AREA 17 & 18

32.86 ACRES, 192 RESIDENTIAL UNITS, 20 TRACTS

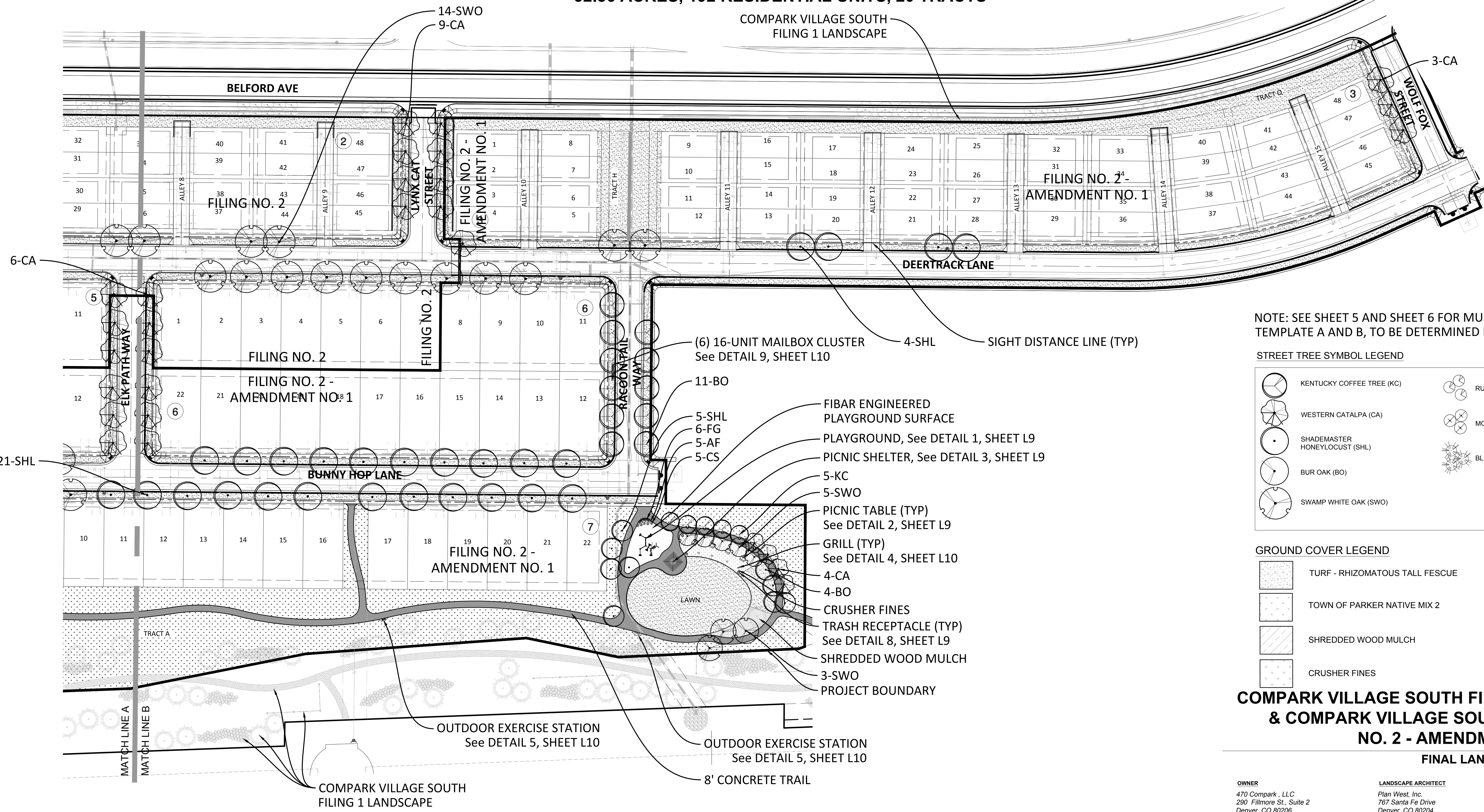

NOTE: SEE SHEET 5 AND SHEET 6 FOR MUSE LANDSCAPE TEMPLATE A AND B, TO BE DETERMINED BY BUILDER.

STREET TREE SYMBOL LEGEND

	KENTUCKY COFFEE TREE (KC)		RUSSIAN SAGE (AF)
	WESTERN CATALPA (CA)		MOONLIGHT BROOM (CS)
	SHADEMASTER HONEYLOCUST (SHL)		BLUE FESCUE (FG)
	BUR OAK (BO)		
	SWAMP WHITE OAK (SWO)		

GROUND COVER LEGEND

	TURF - RHIZOMATOUS TALL FESCUE
	TOWN OF PARKER NATIVE MIX 2
	SHREDDED WOOD MULCH
	CRUSHER FINES

**COMPARK VILLAGE SOUTH FILING NO. 2
& COMPARK VILLAGE SOUTH FILING
NO. 2 - AMENDMENT NO. 1
FINAL LANDSCAPE PLAN**

<p>OWNER 470 Compark, LLC 290 Fillmore St., Suite 2 Denver, CO 80206</p>	<p>LANDSCAPE ARCHITECT Plan West, Inc. 767 Santa Fe Drive Denver, CO 80204 (303) 741-1411</p>	<p>Town of Parker Colorado job no. 2015-20 date 11-22-2016 revisions 07-05-2017</p>
---	--	---

sheet L4 of L14

ENGINEER
Manhard Consulting
8008 E. Arapahoe Ct. Suite 110
Centennial CO 80112
(303) 531-3213

Scale 1" = 60'

PLANWEST

THE REPRODUCTION OF ANY INFORMATION GENERATED BY ARCHITECTS, ENGINEERS OR OTHER CONSULTANTS ON THESE DRAWINGS IS FOR THE EXPRESS PURPOSE OF COORDINATION AND AS A REFERENCE ONLY. INCLUSION OF SAID INFORMATION ON THESE DRAWINGS DOES NOT CONSTITUTE A REPRESENTATION BY PLAN WEST AS TO THE SUFFICIENCY OR ACCURACY OF SAID INFORMATION.

PLANNING | SITE DESIGN | LANDSCAPE ARCHITECTURE | ENTITLEMENTS
 Denver, Colorado, 80204
 303-741-1411
 planwest.com

COMPARK VILLAGE SOUTH FILING NO. 2 & COMPARK VILLAGE SOUTH FILING NO. 2 - AMENDMENT NO. 1 FINAL LANDSCAPE PLAN

A PARCEL OF LAND LOCATED IN THE SOUTH HALF OF SECTION 6, TOWNSHIP 6 SOUTH RANGE 66 WEST OF THE SIXTH PRINCIPAL MERIDIAN,
TOWN OF PARKER, COUNTY OF DOUGLAS, STATE OF COLORADO
PLANNING AREA 17 & 18

32.86 ACRES, 192 RESIDENTIAL UNITS, 20 TRACTS

5' PRIVACY FENCE
See DETAIL 1, SHEET L13

5' CONCRETE SIDEWALK

PLANT SYMBOL LEGEND

	KENTUCKY COFFEE TREE (KC)		DECIDUOUS SHRUB #1
	WESTERN CATALPA (CA)		DECIDUOUS SHRUB #2
	SHADEMASTER HONEYLOCUST (SHL)		ORNAMENTAL GRASS #1
	BUR OAK (BO)		ORNAMENTAL GRASS #2
	SWAMP WHITE OAK (SWO)		EVERGREEN SHRUB #1
	ORNAMENTAL TREE #1		EVERGREEN SHRUB #2
	ORNAMENTAL TREE #2		

GROUND COVER LEGEND

	TURF - RHIZOMATOUS TALL FESCUE
	SHREDDED WOOD MULCH

NOTE: TO BE INSTALLED BY THE DEVELOPER AFTER THE BUILDING IS COMPLETE, NOT PART OF THE LANDSCAPE SCHEDULE OR LANDSCAPE COST ESTIMATE.

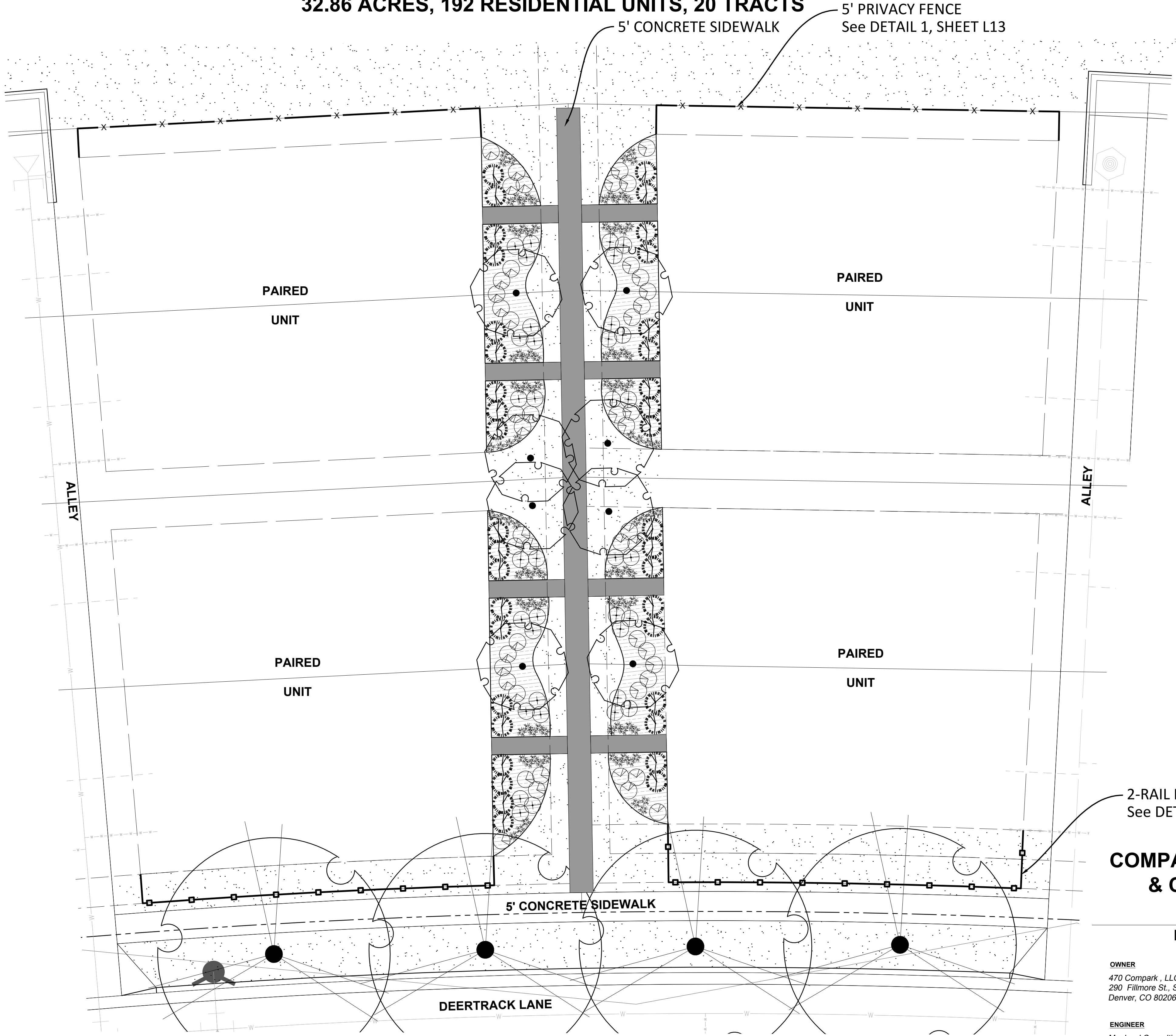

2-RAIL FENCE
See DETAIL 2, SHEET 13

**COMPARK VILLAGE SOUTH FILING NO. 2
& COMPARK VILLAGE SOUTH FILING
NO. 2 - AMENDMENT NO. 1
FINAL LANDSCAPE PLAN - MUSE TEMPLATE 'A'**

OWNER 470 Compark, LLC 290 Fillmore St., Suite 2 Denver, CO 80206	LANDSCAPE ARCHITECT Plan West, Inc. 767 Santa Fe Drive Denver, CO 80204 (303) 741-1411	Town of Parker Colorado job no. 2015-20 date 11-22-2016 revisions 07-05-2017
---	---	--

ENGINEER
Manhard Consulting
8008 E. Arapahoe Ct. Suite 110
Centennial CO 80112
(303) 531-3213

sheet **L5** of **L14**



THE REPRODUCTION OF ANY INFORMATION GENERATED BY ARCHITECTS, ENGINEERS OR OTHER CONSULTANTS ON THESE DRAWINGS IS FOR THE EXPRESS PURPOSE OF COORDINATION AND USE OF REFERENCE ONLY. INCLUSION OF SAID INFORMATION ON THESE DRAWINGS DOES NOT CONSTITUTE A REPRESENTATION BY PLAN WEST AS TO THE SUFFICIENCY OR ACCURACY OF SAID INFORMATION.



PLANNING | SITE DESIGN | LANDSCAPE ARCHITECTURE | ENTITLEMENTS
767 Santa Fe Drive
Denver, Colorado, 80204
303-741-1411

COMPARK VILLAGE SOUTH FILING NO. 2 & COMPARK VILLAGE SOUTH FILING NO. 2 - AMENDMENT NO. 1 FINAL LANDSCAPE PLAN

A PARCEL OF LAND LOCATED IN THE SOUTH HALF OF SECTION 6, TOWNSHIP 6 SOUTH RANGE 66 WEST OF THE SIXTH PRINCIPAL MERIDIAN,
TOWN OF PARKER, COUNTY OF DOUGLAS, STATE OF COLORADO
PLANNING AREA 17 & 18

32.86 ACRES, 192 RESIDENTIAL UNITS, 20 TRACTS

PLANT SYMBOL LEGEND

	KENTUCKY COFFEE TREE (KC)		DECIDUOUS SHRUB #1
	WESTERN CATALPA (CA)		DECIDUOUS SHRUB #2
	SHADEMASTER HONEYLOCUST (SHL)		ORNAMENTAL GRASS #1
	BUR OAK (BO)		ORNAMENTAL GRASS #2
	SWAMP WHITE OAK (SWO)		EVERGREEN SHRUB #1
	ORNAMENTAL TREE #1		EVERGREEN SHRUB #2
	ORNAMENTAL TREE #2		

GROUND COVER LEGEND

	TURF - RHIZOMATOUS TALL FESCUE
	SHREDDED WOOD MULCH

NOTE: TO BE INSTALLED BY THE DEVELOPER AFTER THE BUILDING IS COMPLETE, NOT PART OF THE LANDSCAPE SCHEDULE OR LANDSCAPE COST ESTIMATE.

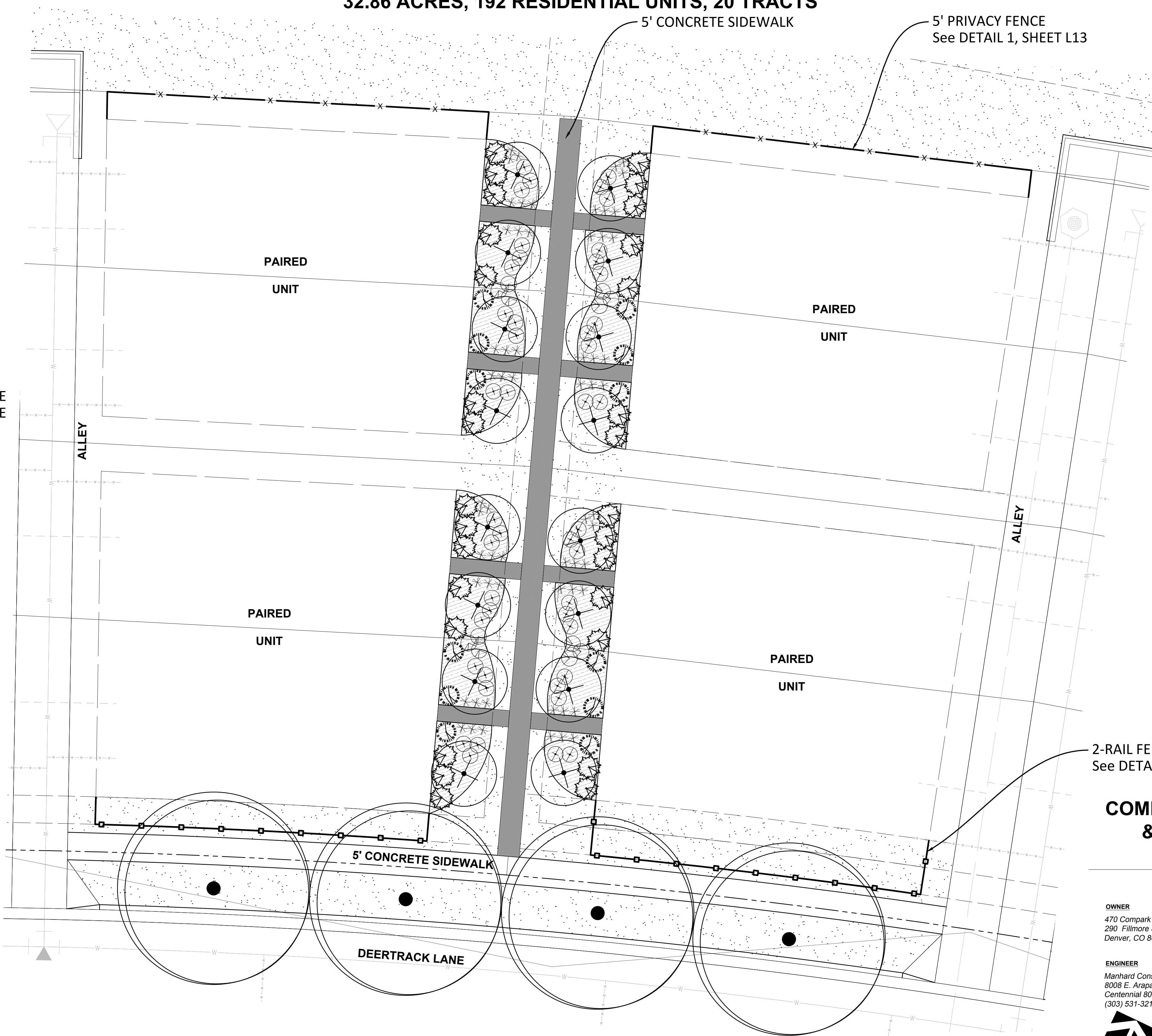

**COMPARK VILLAGE SOUTH FILING NO. 2
& COMPARK VILLAGE SOUTH FILING
NO. 2 - AMENDMENT NO. 1
FINAL LANDSCAPE PLAN - MUSE TEMPLATE 'B'**

OWNER 470 Compark, LLC 290 Fillmore St., Suite 2 Denver, CO 80206	LANDSCAPE ARCHITECT Plan West, Inc. 767 Santa Fe Drive Denver, CO 80204 (303) 741-1411	Town of Parker Colorado job no. 2015-20 date 11-22-2016 revisions 07-05-2017
---	---	--

ENGINEER
Manhard Consulting
8008 E. Arapahoe Ct. Suite 110
Centennial 80112
(303) 531-3213

sheet **L6** of **L14**

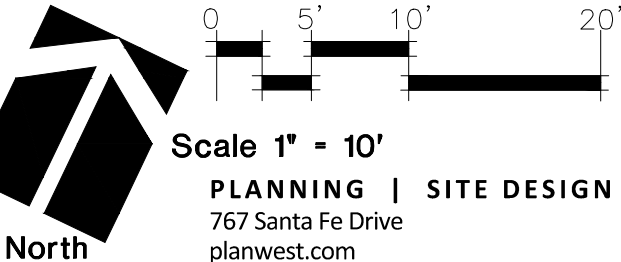

COMPARK VILLAGE SOUTH FILING NO. 2 & COMPARK VILLAGE SOUTH FILING NO. 2 - AMENDMENT NO. 1 FINAL LANDSCAPE PLAN

A PARCEL OF LAND LOCATED IN THE SOUTH HALF OF SECTION 6, TOWNSHIP 6 SOUTH RANGE 66 WEST OF THE SIXTH PRINCIPAL MERIDIAN,
TOWN OF PARKER, COUNTY OF DOUGLAS, STATE OF COLORADO
PLANNING AREA 17 & 18
32.86 ACRES, 192 RESIDENTIAL UNITS, 20 TRACTS

LANDSCAPE PLANT SCHEDULE

FILING NO. 2					
QTY	SYMBOL	COMMON NAME	SCIENTIFIC NAME	HYDRO ZONE	SIZE
DECIDUOUS TREES					
10	CA	Western Catalpa	<i>Catalpa speciosa</i>	Xeric	2.5" Cal.
8	KC	Kentucky Coffee Tree	<i>Gymnocladus dioicus</i>	Xeric	2.5" Cal.
21	SHL	Shademaster Honeylocust	<i>Gleditsia triacanthos inermis</i> 'Shademaster'	Xeric	2.5" Cal.
10	SWO	Swamp White Oak	<i>Quercus bicolor</i>	Xeric	2.5" Cal.
GROUND COVER					
76,700 SF	RTF Turf				Sod
32,000 SF	Native Mix 2				Seed
FILING NO. 2 - AMENDMENT NO. 1					
QTY	SYMBOL	COMMON NAME	SCIENTIFIC NAME	HYDRO ZONE	SIZE
DECIDUOUS TREES					
25	BO	Bur Oak	<i>Quercus macrocarpa</i>	Xeric	2.5" Cal.
18	CA	Western Catalpa	<i>Catalpa speciosa</i>	Xeric	2.5" Cal.
12	KC	Kentucky Coffee Tree	<i>Gymnocladus dioicus</i>	Xeric	2.5" Cal.
35	SHL	Shademaster Honeylocust	<i>Gleditsia triacanthos inermis</i> 'Shademaster'	Xeric	2.5" Cal.
46	SWO	Swamp White Oak	<i>Quercus bicolor</i>	Xeric	2.5" Cal.
DECIDUOUS SHRUBS					
5	AF	Russian Sage	<i>Perovskia artiplicifolia</i>	Xeric	#5
EVERGREEN SHRUBS					
5	CS	Moonlight Broom	<i>Cytisus Scoparius</i> 'Moonlight'	Xeric	#5
PERENNIAL GRASS					
6	FG	Blue Fescue	<i>Festuca glauca</i> 'Elijah Blue'	Xeric	#1
GROUND COVER					
76,700 SF	RTF Turf				Sod
104,500 SF	Native Mix 2				Seed
4,300 SF	Cedar Mulch				
2,900 SF	Crusher Fines				
2,500 SF	Fibar Playground Surface				
NOTE:					
	Town of Parker Native Seed Mix 2				
	22% Slender Wheatgrass				
	18% Sodar Streambank Wheatgrass				
	13% Arizona Fescue				
	13% Blue Grama				
	12% Buffalo Grass				
	12% Barley or Oats				
	5% Spike Muhly				
	5% Indian Rice Grass				

LANDSCAPE NOTES

- THE REPRODUCTION OF ANY INFORMATION GENERATED BY ENGINEERS AND ARCHITECTS ON THESE DRAWINGS IS FOR THE EXPRESS PURPOSE OF COORDINATION AND EASE OF REFERENCE ONLY. INCLUSION OF SAID INFORMATION ON THESE DRAWINGS DOES NOT CONSTITUTE A REPRESENTATION BY PLAN WEST, INC. AS TO THE SUFFICIENCY OR ACCURACY OF SAID INFORMATION.
- VERIFY FIELD CONDITIONS AND NOTIFY THE LANDSCAPE ARCHITECT OF ANY DISCREPANCIES PRIOR TO PROCEEDING WITH THE WORK. PROVIDE A STAKED LAYOUT OF NEW SITE IMPROVEMENTS INCLUDING, BUT NOT LIMITED TO, PLANTING LAYOUT, BED LINES, CONCRETE FLATWORK, PLAYGROUNDS, ENTRY MONUMENTATION, LANDSCAPE WALLS, CONCRETE CURBS, AND TURF AREAS FOR APPROVAL PRIOR TO BEGINNING WORK.
- LOCATION OF EXISTING UTILITIES SHALL BE VERIFIED BY THE CONTRACTOR PRIOR TO ACTUAL CONSTRUCTION. FOR INFORMATION CONTACT THE UTILITY NOTIFICATION CENTER OF COLORADO @ 1-800-922-1987.
- PLANT MATERIAL QUALITY SHALL COMPLY WITH THE CURRENT A.N.A. STANDARDS FOR NURSERY STOCK. PLANT MATERIAL SHALL MEET OR EXCEED THE SIZES SPECIFIED. ALL TREES SHALL HAVE WELL BRANCHED TOPS WITH STRAIGHT, WELL DEVELOPED SINGLE LEADERS UNLESS OTHERWISE SPECIFIED IN THE PLANT SCHEDULE. THE LANDSCAPE ARCHITECT (PLAN WEST, INC.) RESERVES THE RIGHT TO REFUSE PLANT MATERIAL OF IMPROPER QUALITY.
- ALL LANDSCAPED AREAS ARE TO RECEIVE ORGANIC SOIL PREPARATION AT THE RATE OF 4 CY PER 1000 SF AND TILLED TO A DEPTH OF 6 INCHES .
- PLANT MATERIAL WITHIN THE SIGHT TRIANGLES WILL HAVE A MATURE HEIGHT OF 36 INCHES OR LESS ABOVE THE ELEVATION OF THE FLOWLINE. NEW TREES, ONCE MATURE, SHALL BE LIMBED TO A MINIMUM HEIGHT OF 8 FEET.
- CONTRACTOR SHALL SECURE AND PAY ALL APPLICABLE TAXES, PERMITS AND FEES IN CONNECTION WITH THE WORK UNDER THE CONTRACT, PROVIDE FOR PROTECTION OF ALL UTILITIES, PRIVATE OR PUBLIC PROPERTY, PUBLIC SAFETY, AND EXISTING SITE IMPROVEMENTS FOR THE DURATION OF THE CONTRACT AND COSTS TO THE OWNER . THE CONTRACTOR SHALL KEEP THE PREMISES CLEAN AND ORDERLY AND DISPOSE OF WASTE AND DEBRIS AT AN APPROVED LOCATION OFF-SITE DAILY DURING CONSTRUCTION AND PRIOR TO FINAL ACCEPTANCE.
- WITHIN THE SIGHT TRIANGLES, AS SHOWN, LIMITED LANDSCAPING SHALL BE ALLOWED BUT NO SOLID STRUCTURES OR TREES WILL BE PERMITTED. SOLID STRUCTURES SHALL INCLUDE, BUT NOT BE LIMITED TO, FENCES, MAILBOXES, AND UTILITY BOXES. LANDSCAPING WITHIN THE SIGHT TRIANGLES WILL BE LIMITED TO SHRUBS AND PLANTINGS THAT AT MATURITY WILL BE NO TALLER THAN TWO FEET. LANDSCAPING WITHIN THE SIGHT TRIANGLE SHALL BE MAINTAINED BY THE PROPERTY OWNER OR APPROPRIATE ASSOCIATION

COMPARK VILLAGE SOUTH FILING NO. 2 & COMPARK VILLAGE SOUTH FILING NO. 2 - AMENDMENT NO. 1 FINAL LANDSCAPE PLAN - SCHEDULE AND NOTES

OWNER 470 Compark, LLC 290 Fillmore St., Suite 2 Denver, CO 80206	LANDSCAPE ARCHITECT Plan West, Inc. 767 Santa Fe Drive Denver, CO 80204 (303) 741-1411	Town of Parker Colorado job no. 2015-20 date 11-22-2016 revisions 07-05-2017
---	---	--

ENGINEER
 Manhard Consulting
 8008 E. Arapahoe Ct. Suite 110
 Centennial 80112
 (303) 531-3213

sheet L7 of L14



THE REPRODUCTION OF ANY INFORMATION GENERATED BY ARCHITECTS, ENGINEERS OR OTHER CONSULTANTS ON THESE DRAWINGS IS FOR THE EXPRESS PURPOSE OF COORDINATION AND EASE OF REFERENCE ONLY. INCLUSION OF SAID INFORMATION ON THESE DRAWINGS DOES NOT CONSTITUTE A REPRESENTATION BY PLAN WEST AS TO THE SUFFICIENCY OR ACCURACY OF SAID INFORMATION.

COMPARK VILLAGE SOUTH FILING NO. 2 & COMPARK VILLAGE SOUTH FILING NO. 2 - AMENDMENT NO. 1 FINAL LANDSCAPE PLAN

A PARCEL OF LAND LOCATED IN THE SOUTH HALF OF SECTION 6, TOWNSHIP 6 SOUTH RANGE 66 WEST OF THE SIXTH PRINCIPAL MERIDIAN, TOWN OF PARKER, COUNTY OF DOUGLAS, STATE OF COLORADO
PLANNING AREA 17 & 18
32.86 ACRES, 192 RESIDENTIAL UNITS, 20 TRACTS

TOWN OF PARKER PLANTING STANDARDS

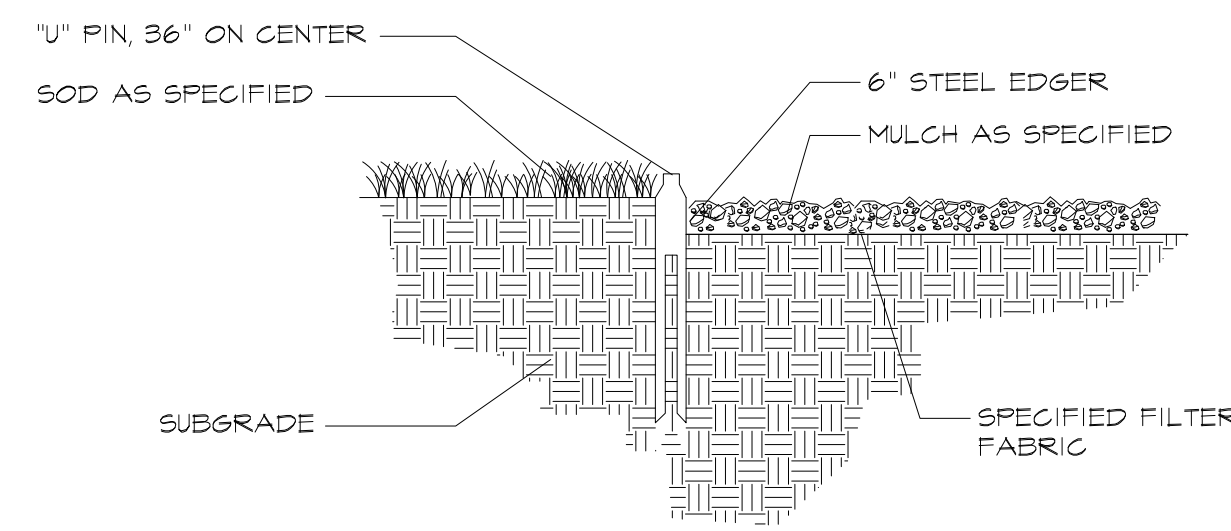

1

STEEL EDGER DETAIL

NOT TO SCALE

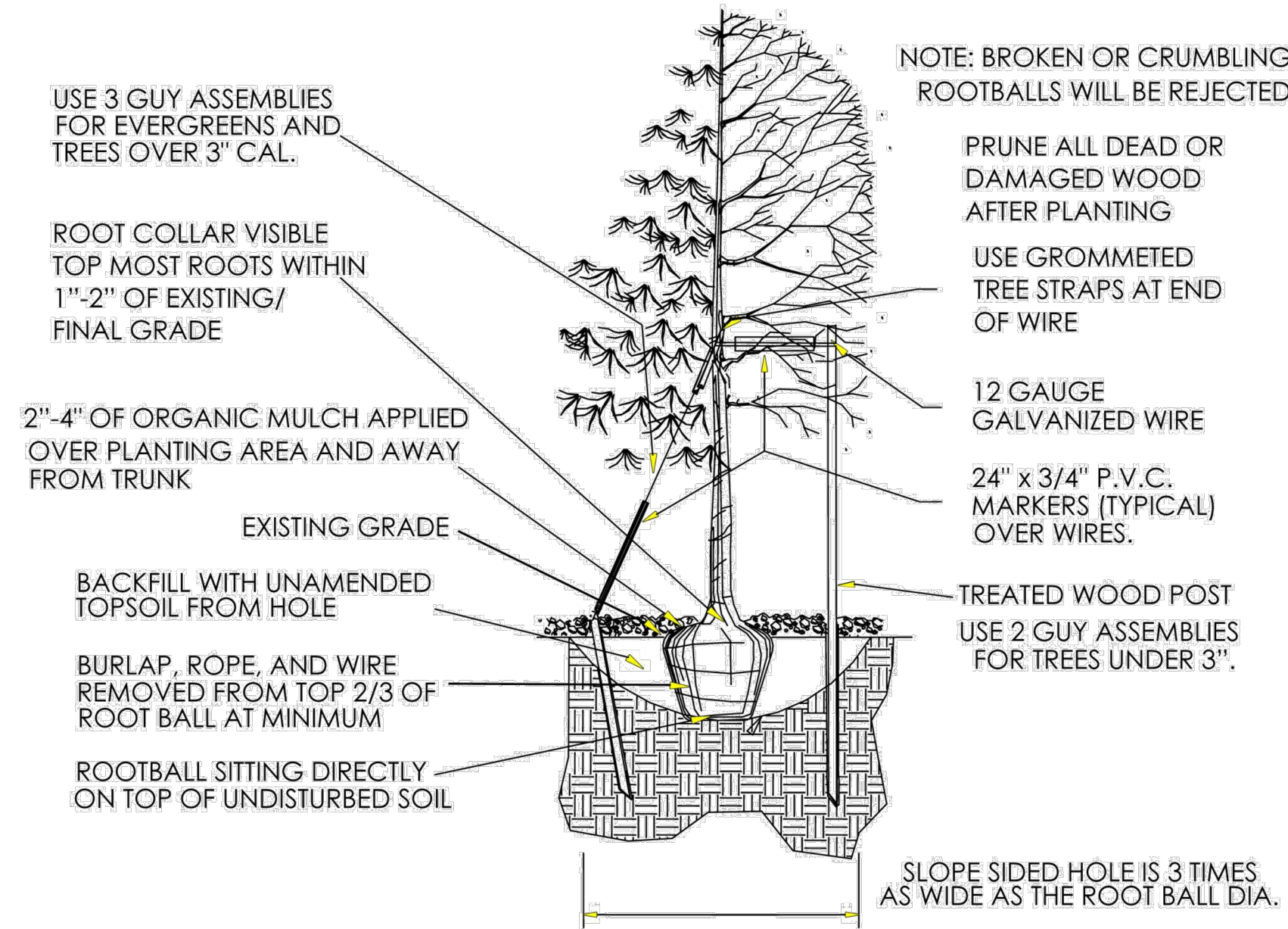

- Excavate planting holes with sloping sides. Make excavations at least three times as wide as the root ball diameter and no deeper than the distance from the top most roots in the root ball to the bottom of the root ball to allow for settling. Do not disturb soil at bottom of planting holes, but do score the sides of the planting hole. The planting area shall be loosened and aerated at least three times the diameter of the root ball. Backfill shall consist of existing on site topsoil – no amendments shall be used unless otherwise specified.
- Trees shall be planted with the root collar/flare visible above grade AND two or more structural roots located within the top 1" to 2" of the root ball/finished grade measured 3" to 4" from trunk. This includes trees that are set on slopes (see slope planting detail). Trees that do not have a visible root collar shall be rejected. Do not cover the root ball with soil.
- When root ball will remain intact, cut off bottom 1/4 of wire basket before placing tree in hole, cut off remainder of basket AFTER tree is set in hole, remove basket completely. At a minimum, the top 2/3 of the burlap and basket shall be removed from the root ball on all trees. Remove all nylon ties, twine, rope and burlap. Remove unnecessary packing material.
- Form soil into a 3" to 5" tall watering ring (saucer) around planting area. This is not necessary in irrigated turf areas. Apply 2" to 4" depth of specified mulch over planting area and inside saucers, away from trunk.
- Staking and guying of trees is optional in most planting situations. In areas of extreme winds, or on steep slopes, staking may be required to stabilize trees. Staking and guying must be removed within 1 year of planting date.
- Tree wrap is *not* to be used on any new plantings, except in late fall planting situations, and only then after consultation with the Town Arborist.
- Resetting of improperly planted trees will only be allowed if it is determined that doing so will in no way compromise the root ball, and shall only be done with approval of the Town Arborist.

3

TYPICAL TREE PLANTING DETAIL

NOT TO SCALE

TOWN OF PARKER TREE PLANTING DETAIL - SLOPES

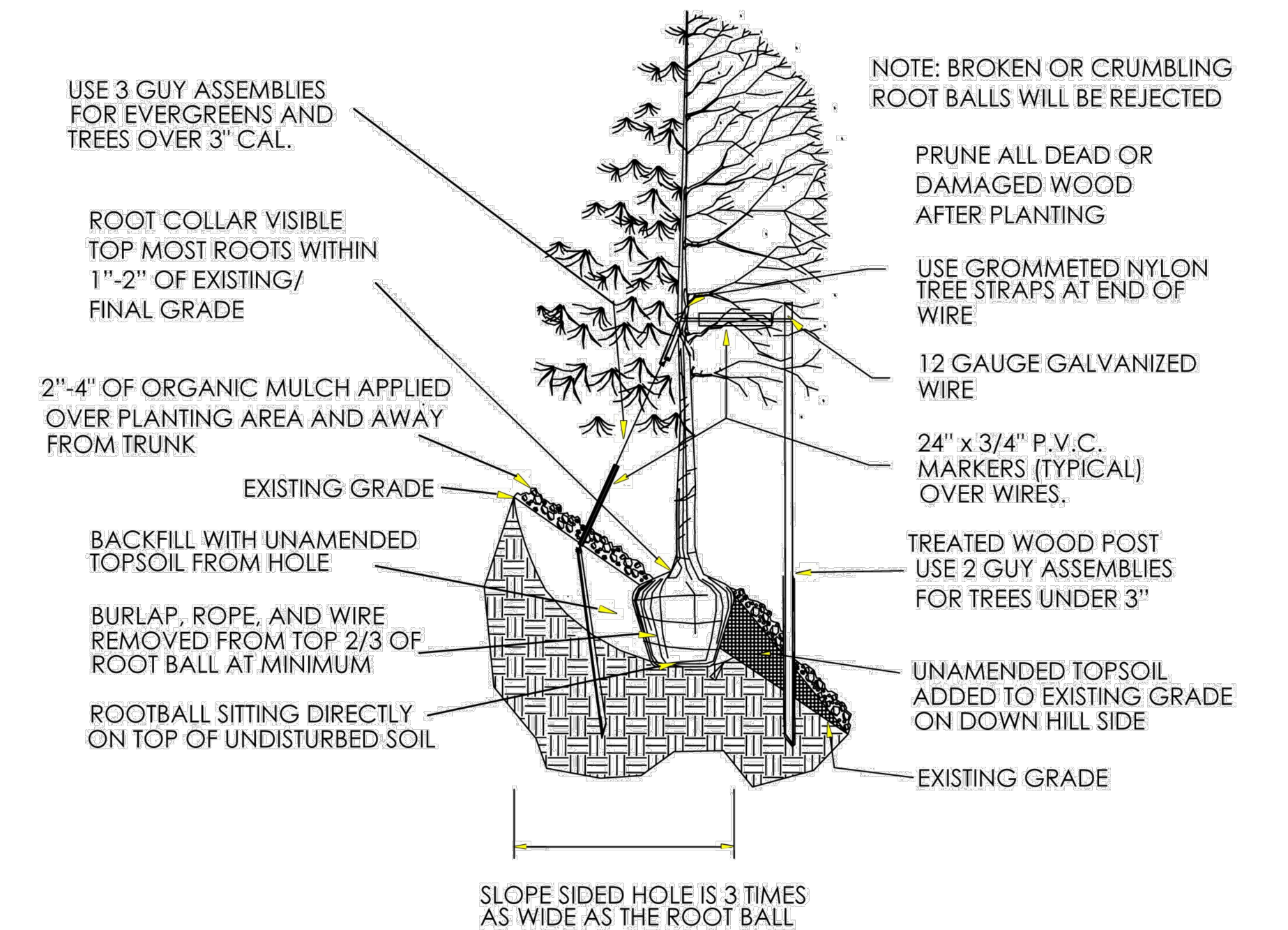

4

TYPICAL TREE PLANTING DETAIL (ON SLOPE)

NOT TO SCALE

TOWN OF PARKER PLANTING DETAIL - SHRUBS

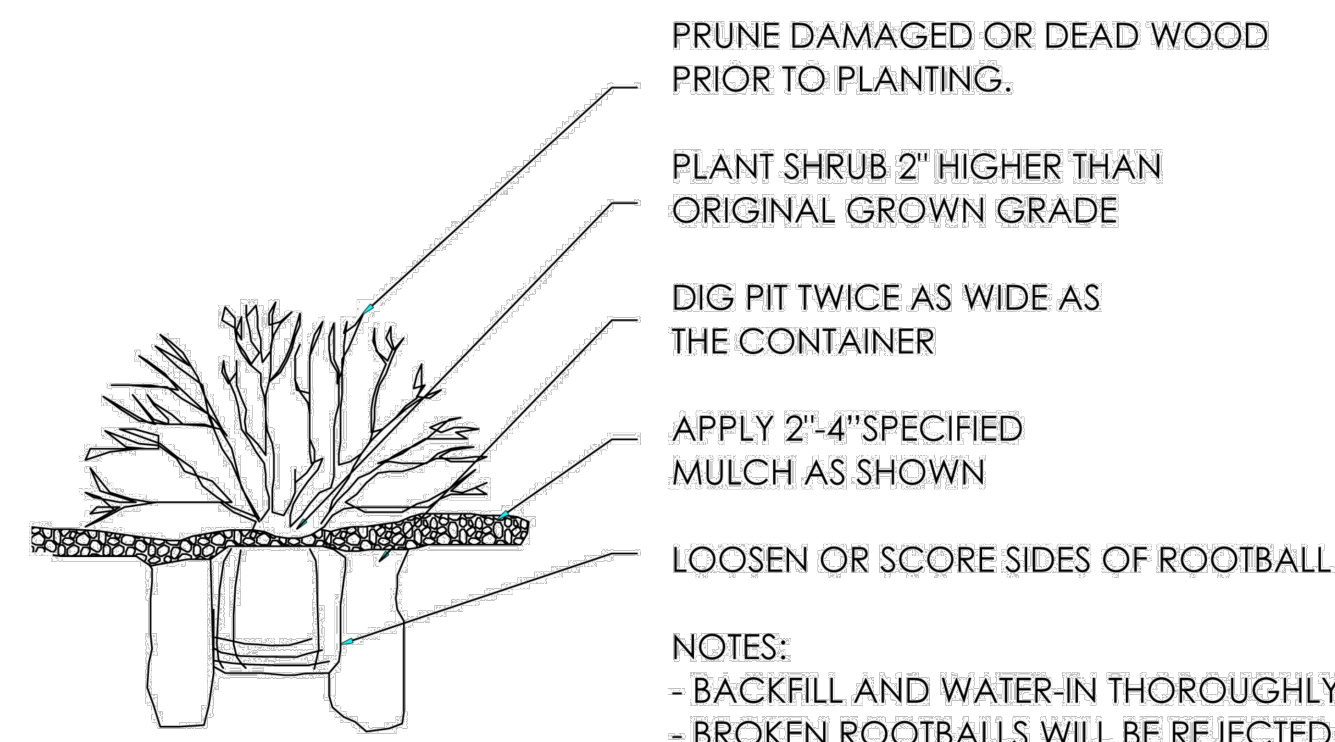

2

TYPICAL SHRUB PLANTING DETAIL

NOT TO SCALE

COMPARK VILLAGE SOUTH FILING NO. 2 & COMPARK VILLAGE SOUTH FILING NO. 2 - AMENDMENT NO. 1 FINAL LANDSCAPE PLAN - DETAILS

OWNER
 470 Compark, LLC
 290 Fillmore St., Suite 2
 Denver, CO 80206

LANDSCAPE ARCHITECT
 Plan West, Inc.
 767 Santa Fe Drive
 Denver, CO 80204
 (303) 741-1411

Town of Parker
 Colorado

job no. 2015-20
 date 11-22-2016
 revisions 07-05-2017

ENGINEER
 Manhard Consulting
 8008 E. Arapahoe Ct. Suite 110
 Centennial 80112
 (303) 531-3213

sheet **L8** of **L14**



THE REPRODUCTION OF ANY INFORMATION GENERATED BY ARCHITECTS, ENGINEERS OR OTHER CONSULTANTS ON THESE DRAWINGS IS FOR THE EXPRESS PURPOSE OF COORDINATION AND USE OF REFERENCE ONLY. INCLUSION OF SAID INFORMATION ON THESE DRAWINGS DOES NOT CONSTITUTE A REPRESENTATION BY PLAN WEST AS TO THE SUFFICIENCY OR ACCURACY OF SAID INFORMATION.

PLANNING | SITE DESIGN | LANDSCAPE ARCHITECTURE | ENTITLEMENTS
 767 Santa Fe Drive
 planwest.com
 Denver, Colorado, 80204
 303-741-1411

COMPARK VILLAGE SOUTH FILING NO. 2 & COMPARK VILLAGE SOUTH FILING NO. 2 - AMENDMENT NO. 1 FINAL LANDSCAPE PLAN

A PARCEL OF LAND LOCATED IN THE SOUTH HALF OF SECTION 6, TOWNSHIP 6 SOUTH RANGE 66 WEST OF THE SIXTH PRINCIPAL MERIDIAN, TOWN OF PARKER, COUNTY OF DOUGLAS, STATE OF COLORADO
 PLANNING AREA 17 & 18
 32.86 ACRES, 192 RESIDENTIAL UNITS, 20 TRACTS

PRELIMINARY: NOT FOR CONSTRUCTION



Elevation

DRAWN BY: LB

DATE: 11/4/2014

JOB NO.: STANDARD

REVISION:

BUILDING TYPE: HX24T2V-P4

PROJECT NAME:

SHEET 1

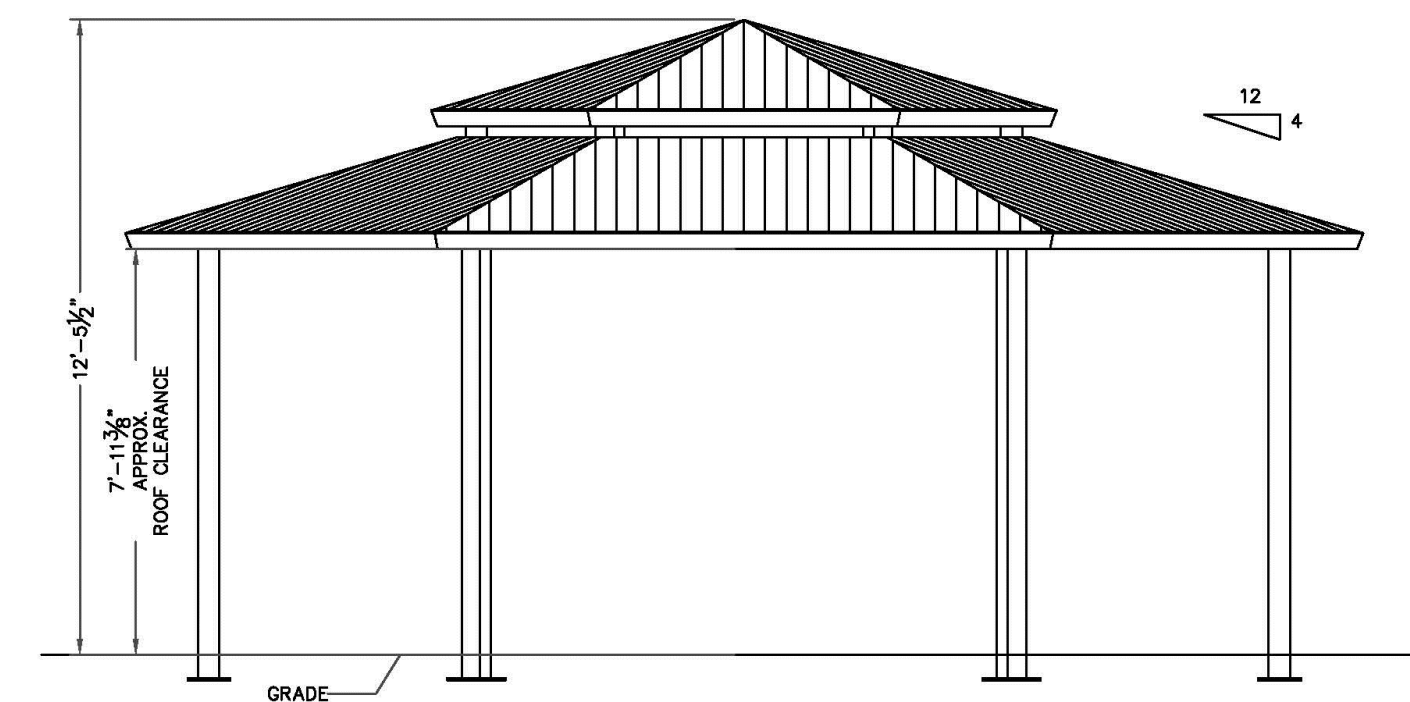
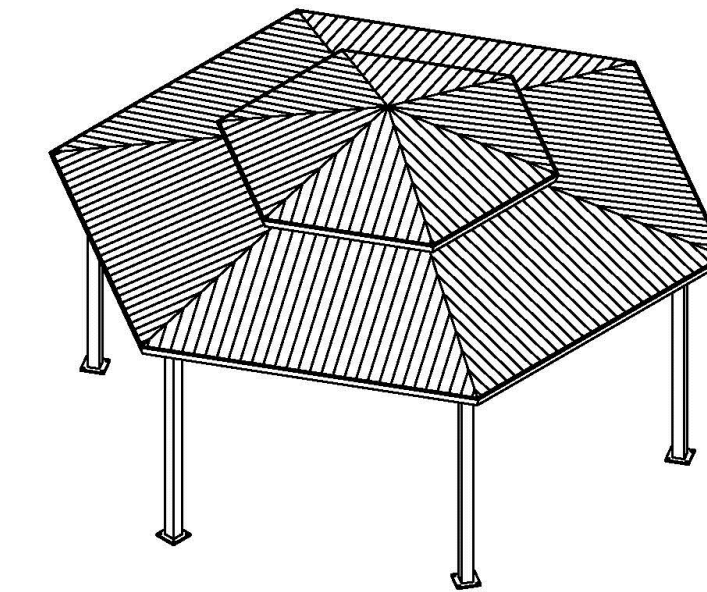

2 PICNIC SHELTER DETAIL

NOT TO SCALE

General Notes:

Age Group
 2-5 year 5-12 year 12-17 year

- The Americans with Disabilities Act (ADA) may require that you make your park and/or playground accessible when viewed in its entirety. Please consult your legal counsel to determine if the ADA applies to you.
- For playground equipment to be considered accessible, accessible surfacing must be utilized in appropriate areas.
- Although a particular playground design may not meet the proposed Access Board Regulations in regards to the appropriate number of ground level events, the actual playground may be in compliance when considering existing play components.
- All deck heights are measured from top of ground cover around all play equipment.
- Fall absorbing ground cover is required under and around all play equipment.
- The minimum recommended fall zone around the entire apparatus is shown. This zone is to be free of all tripping or collision hazards (i.e. rocks, roots, border materials, etc.).
- All post lengths are identified by text showing the post heights, i.e. 36" represents a 36" high post.
- Not all equipment may be appropriate for all children. Supervision is required.

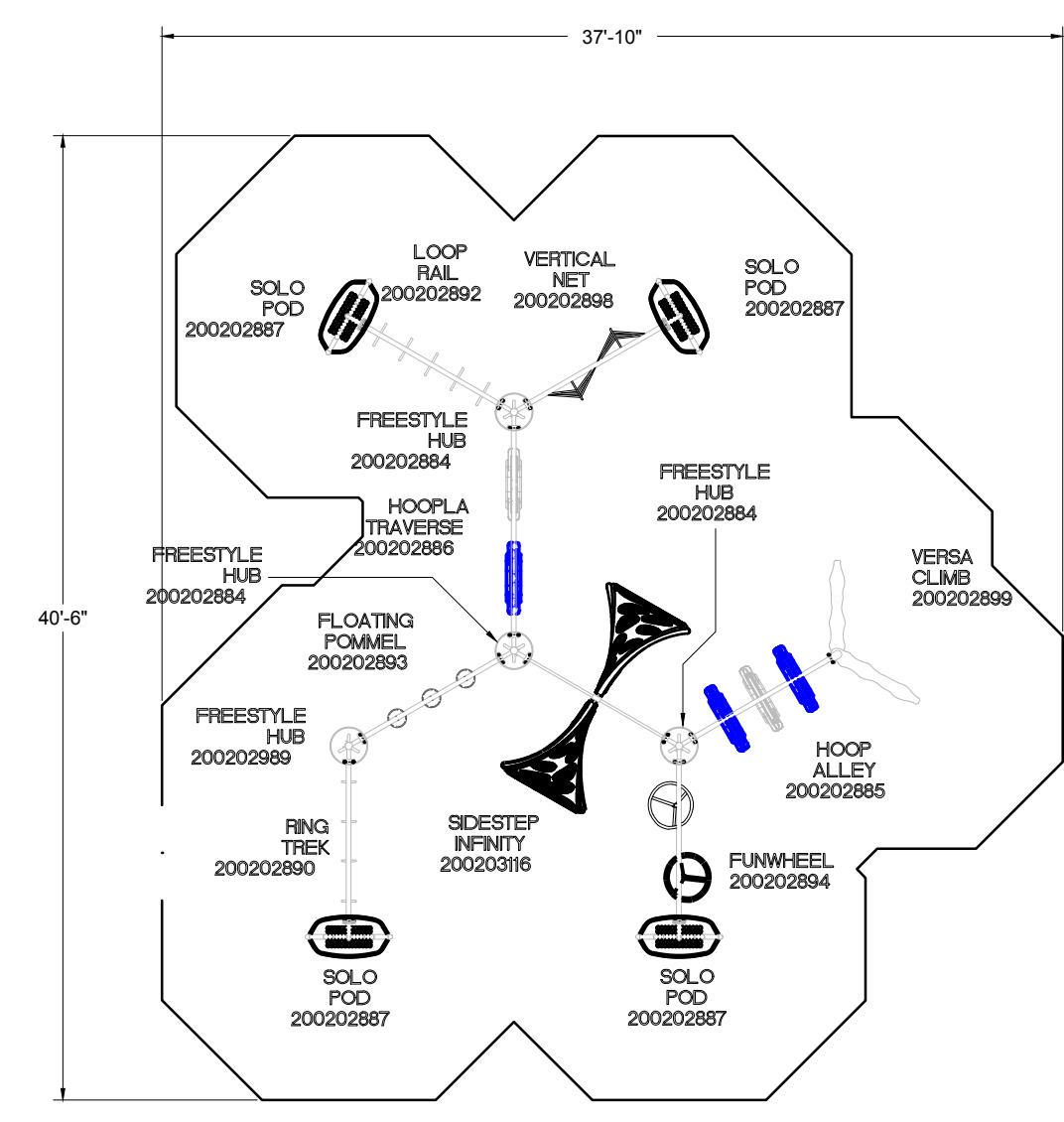

Project: 2016 CATALOG

LTCPs rep:
 LTCPs
 800-325-8828

Drawn by: Bill Weber
 Date: 09/15/2015
 DWG Name: QU066044
 Scale: 1/8"=1'

Approved by:
 LTCPs - Farmington
 One Iron Mountain Drive
 Farmington, Missouri 63640
 Voice: 1-800-325-8828
 Fax: 573-756-0319

COLOR: MINT FUDGE SWIRL

Minimal recommended fallzone
 Area 1177 sq. feet
 Perimeter 154 feet

Playground Layout Compliance: ASTM F1487 - Playground Equipment for Public Use This playground design meets final Access Board Regulations. CPSC Handbook for Public Playground Safety

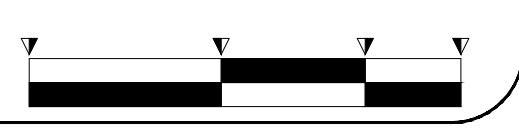
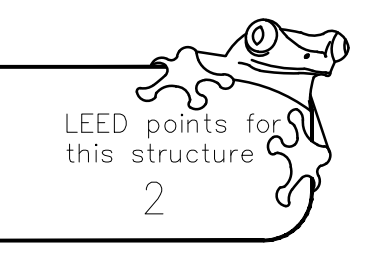

1 PLAYGROUND DETAIL

1/8"=1'-0"

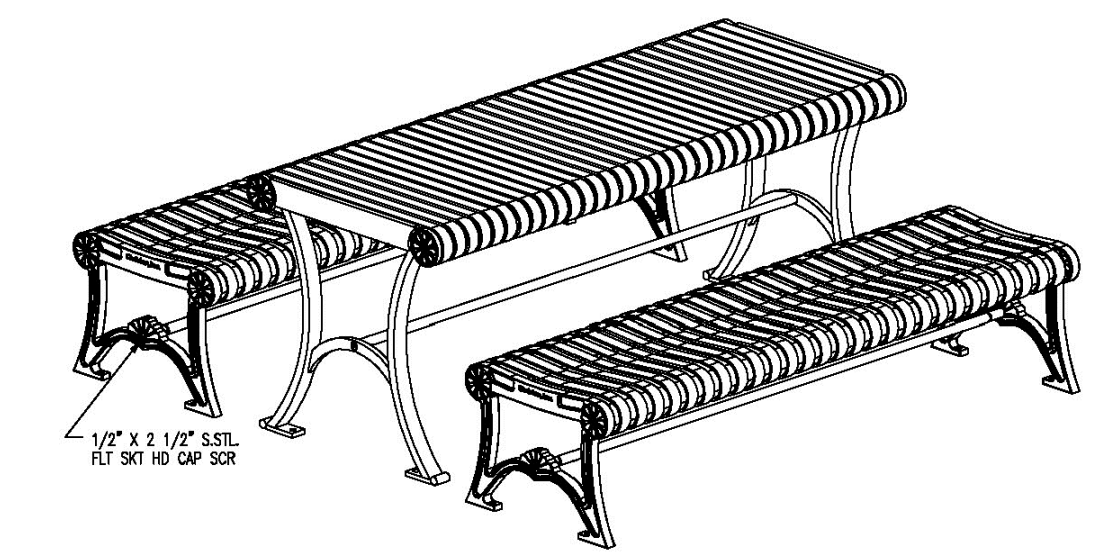
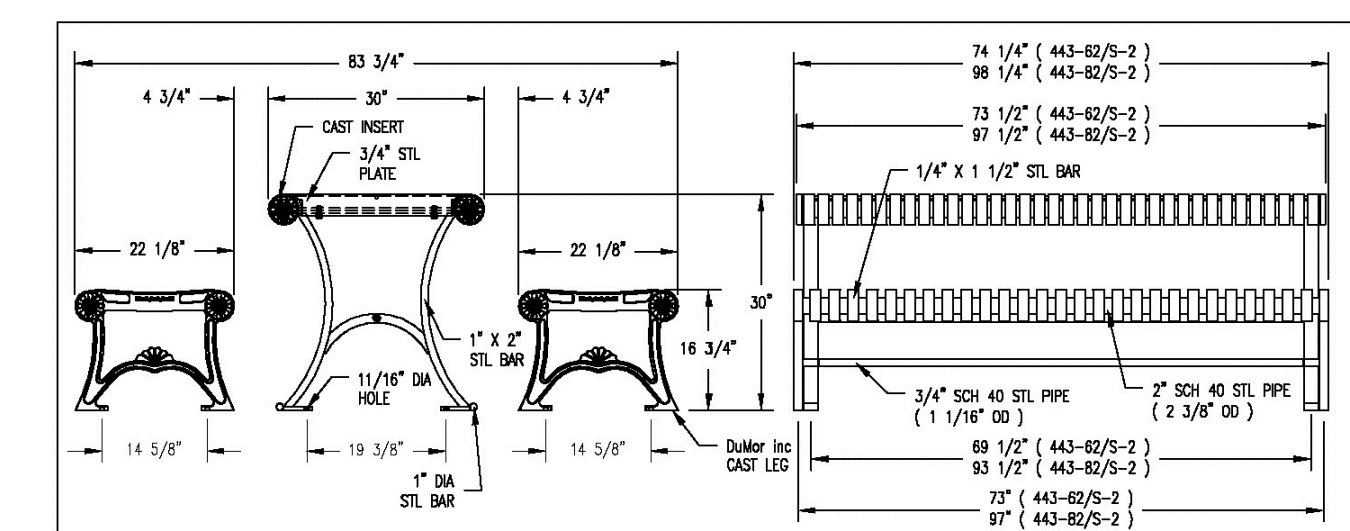

- NOTES
- ALL STL. MEMBERS COATED W/ ZINC RICH EPOXY THEN FINISHED W/ POLYESTER POWDER COATING.
 - ALL WELDS CONT. THEN GROUND SMOOTH.
 - 1/2" X 3 3/4" EXPANSION ANCHOR BOLTS PROVIDED.

- LENGTH OPTIONS
- 6' TABLE
 - 8' TABLE

DuMar, Inc. TABLE DATE DRAWN: 11/6/13 DATE REV. 1: 09/25/00 REV. BY: XXX DRAWING NUMBER 443 SERIES-2/S-2 SHEET 1 OF 3

3 PICNIC TABLE DETAIL

NOT TO SCALE

COMPARK VILLAGE SOUTH FILING NO. 2 & COMPARK VILLAGE SOUTH FILING NO. 2 - AMENDMENT NO. 1 FINAL LANDSCAPE PLAN - DETAILS

OWNER: 470 Compark, LLC, 290 Fillmore St., Suite 2, Denver, CO 80206

LANDSCAPE ARCHITECT: Plan West, Inc., 767 Santa Fe Drive, Denver, CO 80204, (303) 741-1411

Town of Parker, Colorado

job no. 2015-20
 date 11-22-2016
 revisions 07-05-2017

ENGINEER: Manhard Consulting, 8006 E. Arapahoe Ct. Suite 110, Centennial CO 80112, (303) 531-3213

sheet L9 of L14



COMPARK VILLAGE SOUTH FILING NO. 2 & COMPARK VILLAGE SOUTH FILING NO. 2 - AMENDMENT NO. 1 FINAL LANDSCAPE PLAN

A PARCEL OF LAND LOCATED IN THE SOUTH HALF OF SECTION 6, TOWNSHIP 6 SOUTH RANGE 66 WEST OF THE SIXTH PRINCIPAL MERIDIAN, TOWN OF PARKER, COUNTY OF DOUGLAS, STATE OF COLORADO
PLANNING AREA 17 & 18

32.86 ACRES, 192 RESIDENTIAL UNITS, 20 TRACTS

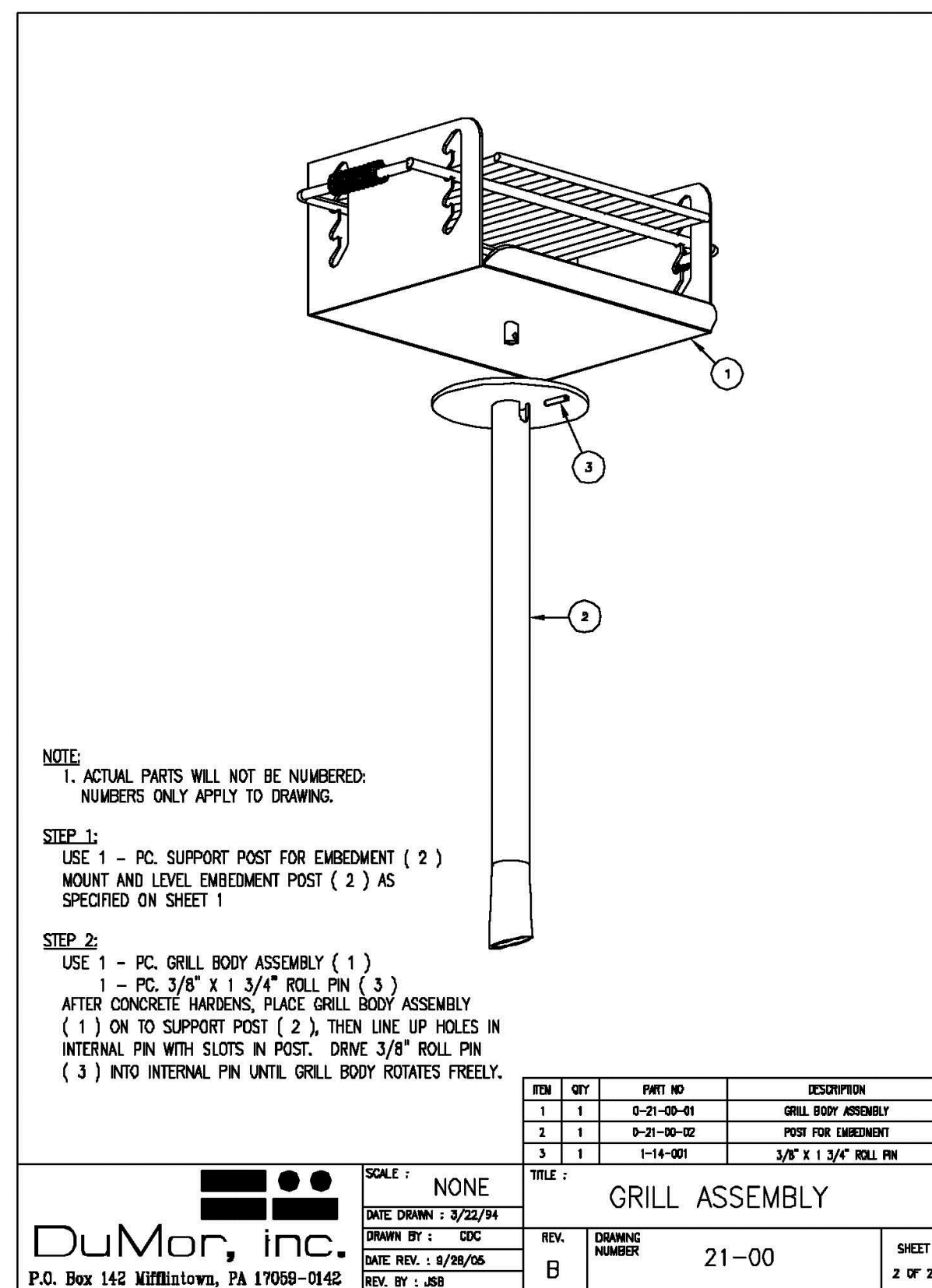
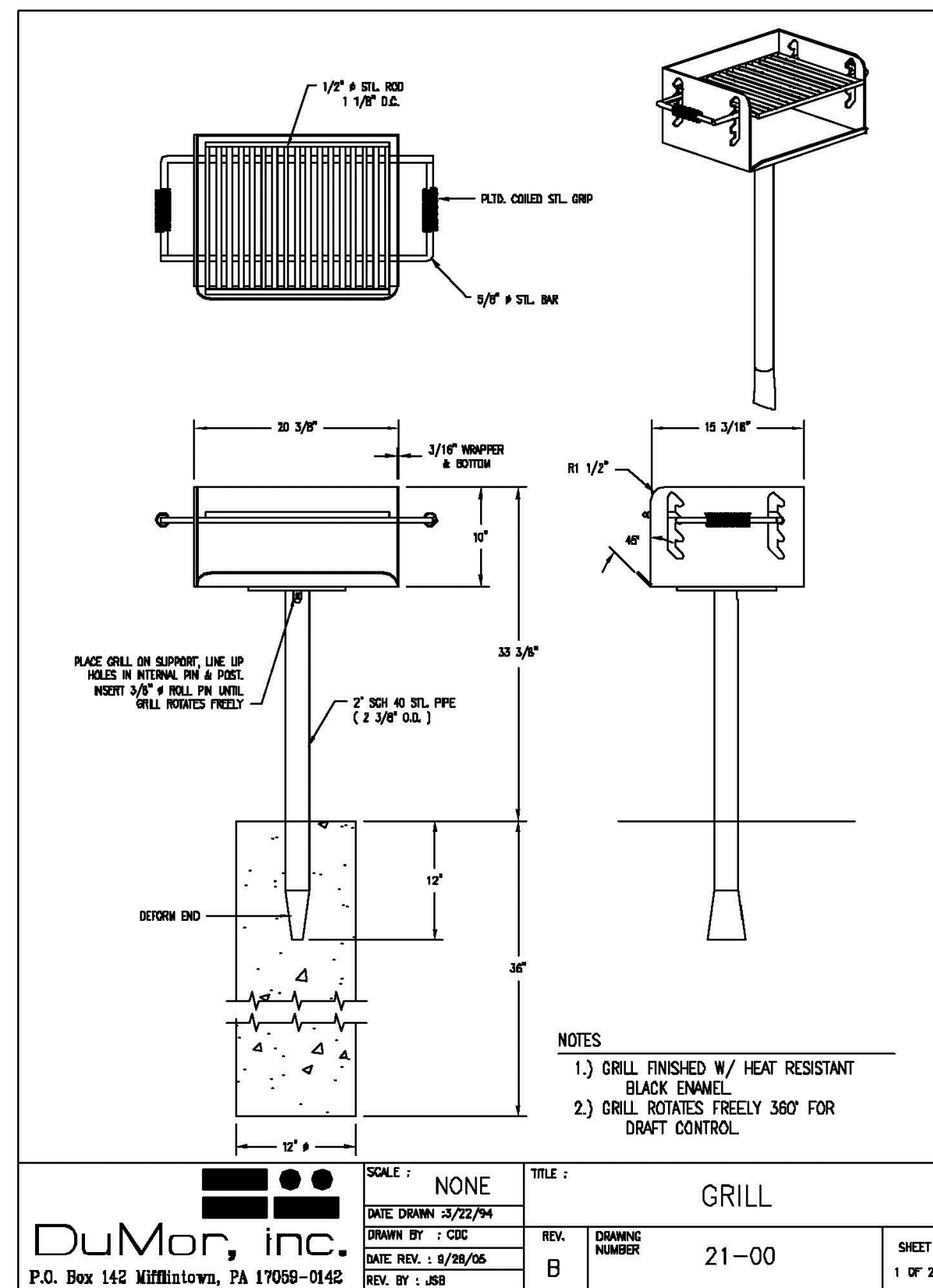

4 GRILL DETAIL NOT TO SCALE



5 OUTDOOR FITNESS DETAIL NOT TO SCALE



6 OUTDOOR FITNESS DETAIL NOT TO SCALE



7 OUTDOOR FITNESS DETAIL NOT TO SCALE

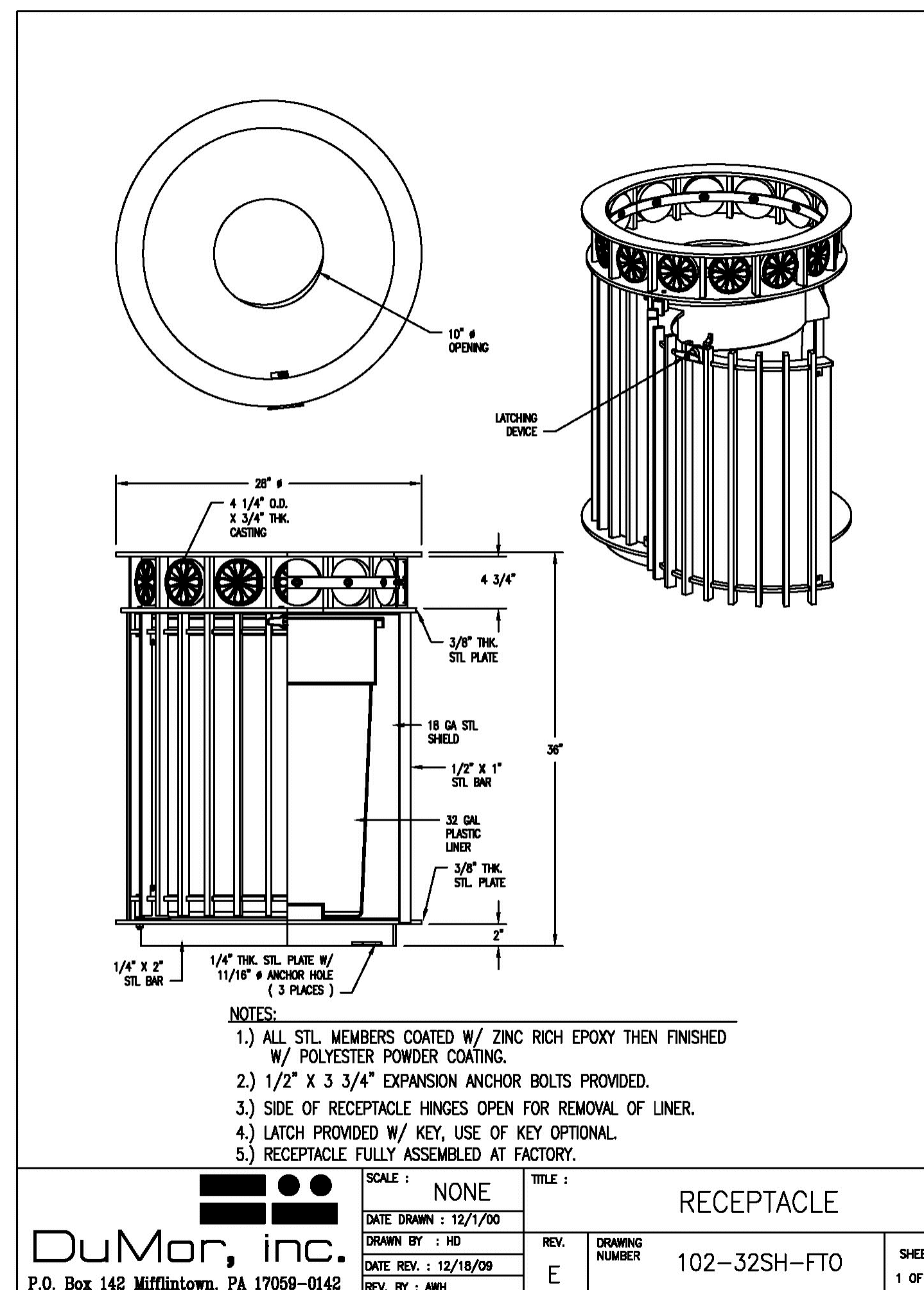

8 TRASH RECEPTACLE DETAIL NOT TO SCALE

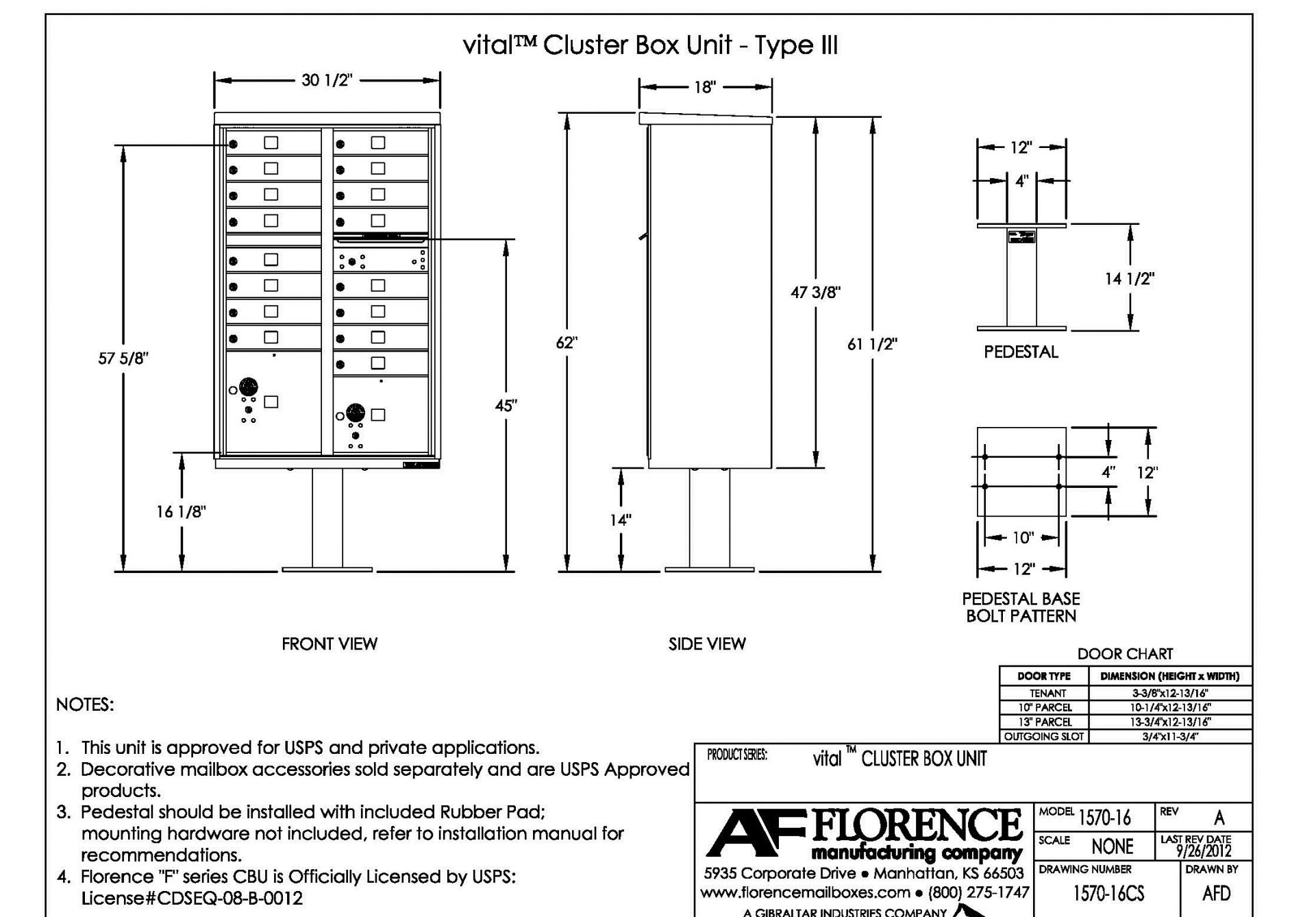

9 (12) 16-TENANT MAILBOX CLUSTER DETAIL: COLOR = BLACK Specification Sheet by AF Florence NOT TO SCALE

COMPARK VILLAGE SOUTH FILING NO. 2 & COMPARK VILLAGE SOUTH FILING NO. 2 - AMENDMENT NO. 1 FINAL LANDSCAPE PLAN - DETAILS

OWNER: 470 Compark, LLC, 290 Fillmore St., Suite 2, Denver, CO 80206

LANDSCAPE ARCHITECT: Plan West, Inc., 767 Santa Fe Drive, Denver, CO 80204, (303) 741-1411

ENGINEER: Manhard Consulting, 8008 E. Arapahoe Ct. Suite 110, Centennial CO 80112, (303) 531-3213

Town of Parker, Colorado
job no. 2015-20
date 11-22-2016
revisions 07-05-2017

sheet L10 of L14



THE REPRODUCTION OF ANY INFORMATION, GENERATED BY ARCHITECTS, ENGINEERS OR OTHER CONSULTANTS ON THESE DRAWINGS IS FOR THE EXPRESS PURPOSE OF COORDINATION AND AS A REFERENCE ONLY. INCLUSION OF SAID INFORMATION ON THESE DRAWINGS DOES NOT CONSTITUTE A REPRESENTATION BY PLAN WEST AS TO THE SUFFICIENCY OR ACCURACY OF SAID INFORMATION.

COMPARK VILLAGE SOUTH FILING NO. 2 & COMPARK VILLAGE SOUTH FILING NO. 2 - AMENDMENT NO. 1 FINAL LANDSCAPE PLAN

A PARCEL OF LAND LOCATED IN THE SOUTH HALF OF SECTION 6, TOWNSHIP 6 SOUTH RANGE 66 WEST OF THE SIXTH PRINCIPAL MERIDIAN,
TOWN OF PARKER, COUNTY OF DOUGLAS, STATE OF COLORADO
PLANNING AREA 17 & 18
32.86 ACRES, 192 RESIDENTIAL UNITS, 20 TRACTS

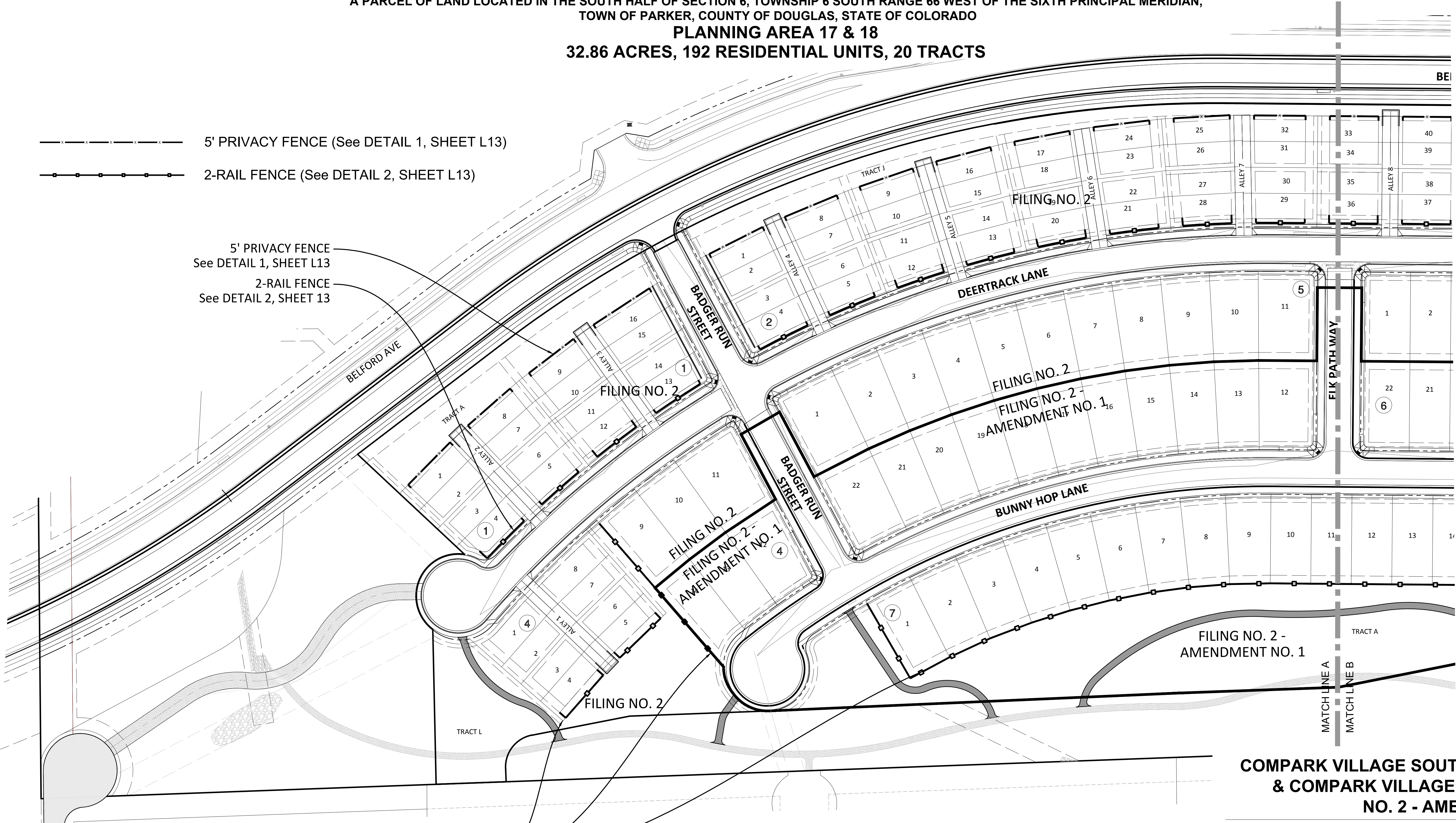

- 5' PRIVACY FENCE (See DETAIL 1, SHEET L13)
- 2-RAIL FENCE (See DETAIL 2, SHEET L13)

5' PRIVACY FENCE
See DETAIL 1, SHEET L13
2-RAIL FENCE
See DETAIL 2, SHEET L13

2-RAIL FENCE
See DETAIL 2, SHEET L13

COMPARK VILLAGE SOUTH FILING NO. 2 & COMPARK VILLAGE SOUTH FILING NO. 2 - AMENDMENT NO. 1 FINAL LANDSCAPE PLAN - FENCING PLAN

<p>OWNER 470 Compark, LLC 290 Fillmore St., Suite 2 Denver, CO 80206</p>	<p>LANDSCAPE ARCHITECT Plan West, Inc. 767 Santa Fe Drive Denver, CO 80204 (303) 741-1411</p>	<p style="text-align: right;">Town of Parker Colorado</p> <p>job no. 2015-20 date 11-22-2016 revisions 07-05-2017</p>
---	--	---

sheet L11 of L14

ENGINEER
Manhard Consulting
8008 E. Arapahoe Ct. Suite 110
Centennial CO 80112
(303) 531-3213

Scale 1" = 60'

PLANWEST

THE REPRODUCTION OF ANY INFORMATION GENERATED BY ARCHITECTS, ENGINEERS OR OTHER CONSULTANTS ON THESE DRAWINGS IS FOR THE EXPRESS PURPOSE OF COORDINATION AND AS A REFERENCE ONLY. INCLUSION OF SAID INFORMATION ON THESE DRAWINGS DOES NOT CONSTITUTE A REPRESENTATION BY PLAN WEST AS TO THE SUFFICIENCY OR ACCURACY OF SAID INFORMATION.

PLANNING | SITE DESIGN | LANDSCAPE ARCHITECTURE | ENTITLEMENTS
Denver, Colorado, 80204
303-741-1411

COMPARK VILLAGE SOUTH FILING NO. 2 & COMPARK VILLAGE SOUTH FILING NO. 2 - AMENDMENT NO. 1 FINAL LANDSCAPE PLAN

A PARCEL OF LAND LOCATED IN THE SOUTH HALF OF SECTION 6, TOWNSHIP 6 SOUTH RANGE 66 WEST OF THE SIXTH PRINCIPAL MERIDIAN,
TOWN OF PARKER, COUNTY OF DOUGLAS, STATE OF COLORADO
PLANNING AREA 17 & 18
32.86 ACRES, 192 RESIDENTIAL UNITS, 20 TRACTS

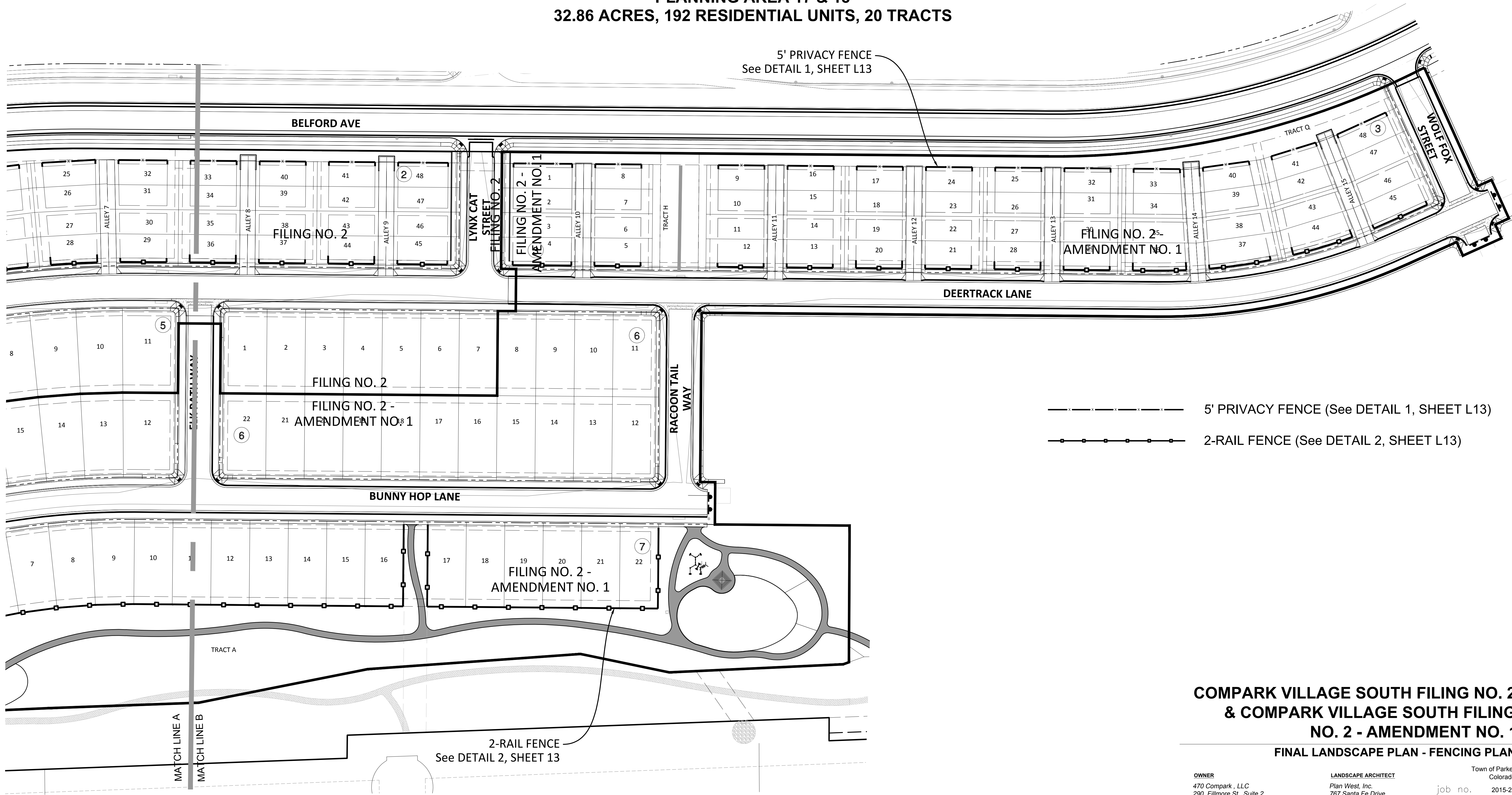

COMPARK VILLAGE SOUTH FILING NO. 2 & COMPARK VILLAGE SOUTH FILING NO. 2 - AMENDMENT NO. 1 FINAL LANDSCAPE PLAN - FENCING PLAN

<p>OWNER 470 Compark, LLC 290 Fillmore St., Suite 2 Denver, CO 80206</p>	<p>LANDSCAPE ARCHITECT Plan West, Inc. 767 Santa Fe Drive Denver, CO 80204 (303) 741-1411</p>	<p style="text-align: right;">Town of Parker Colorado</p> <p>job no. 2015-20 date 11-22-2016 revisions 07-05-2017</p>
---	--	---

sheet L12 of L14

ENGINEER
Manhard Consulting
8008 E. Arapahoe Ct. Suite 110
Centennial CO 80112
(303) 531-3213

Scale 1" = 60'

PLANWEST

THE REPRODUCTION OF ANY INFORMATION GENERATED BY ARCHITECTS, ENGINEERS OR OTHER CONSULTANTS ON THESE DRAWINGS IS FOR THE EXPRESS PURPOSE OF COORDINATION AND EASE OF REFERENCE ONLY. INCLUSION OF SAID INFORMATION ON THESE DRAWINGS DOES NOT CONSTITUTE A REPRESENTATION BY PLAN WEST AS TO THE SUFFICIENCY OR ACCURACY OF SAID INFORMATION.

PLANNING | SITE DESIGN | LANDSCAPE ARCHITECTURE | ENTITLEMENTS
 Denver, Colorado, 80204
 303-741-1411

COMPARK VILLAGE SOUTH FILING NO. 2 & COMPARK VILLAGE SOUTH FILING NO. 2 - AMENDMENT NO. 1 FINAL LANDSCAPE PLAN

A PARCEL OF LAND LOCATED IN THE SOUTH HALF OF SECTION 6, TOWNSHIP 6 SOUTH RANGE 66 WEST OF THE SIXTH PRINCIPAL MERIDIAN,
TOWN OF PARKER, COUNTY OF DOUGLAS, STATE OF COLORADO
PLANNING AREA 17 & 18
32.86 ACRES, 192 RESIDENTIAL UNITS, 20 TRACTS

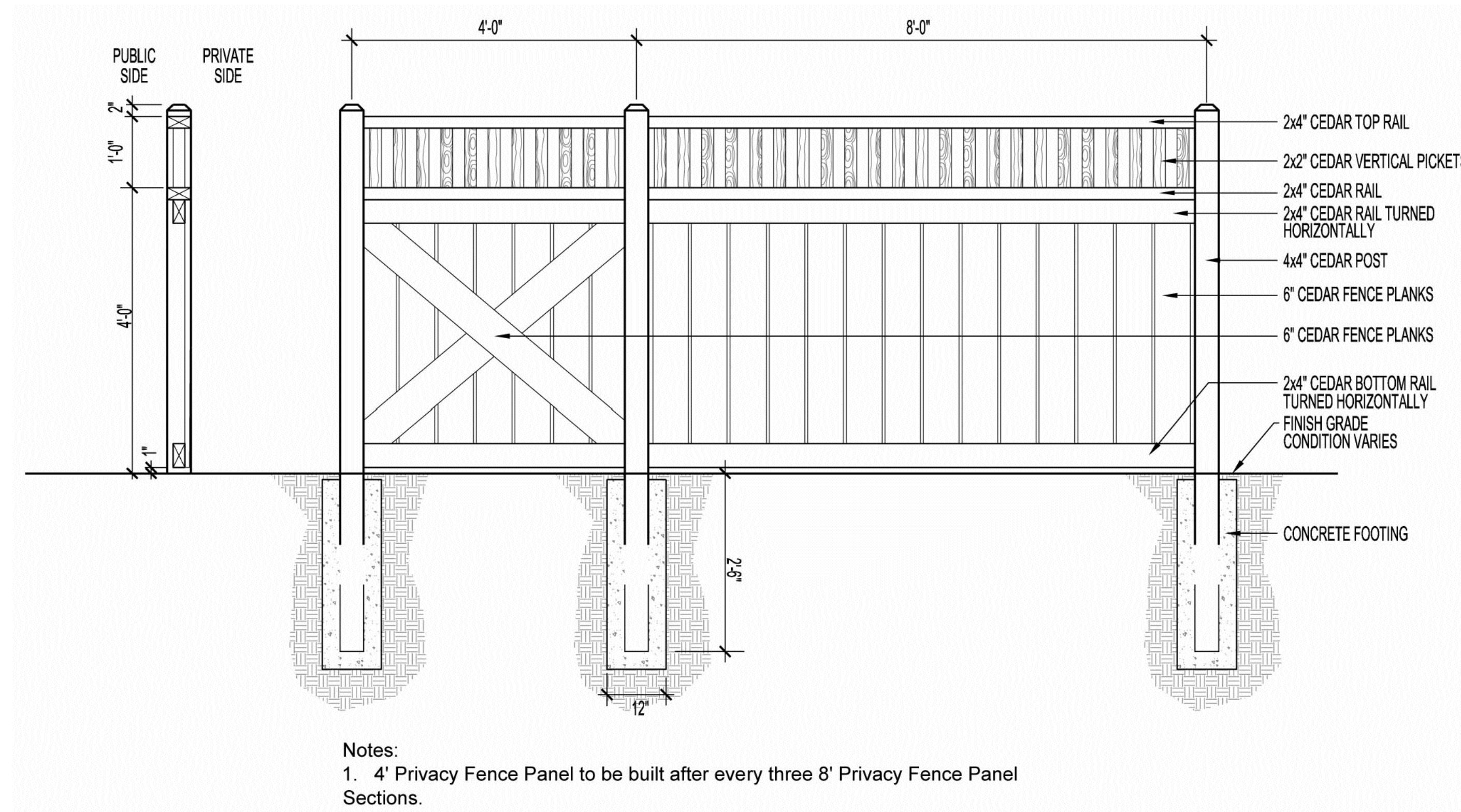

1 5' PRIVACY FENCE DETAIL
TOWN OF PARKER STANDARD

NOT TO SCALE

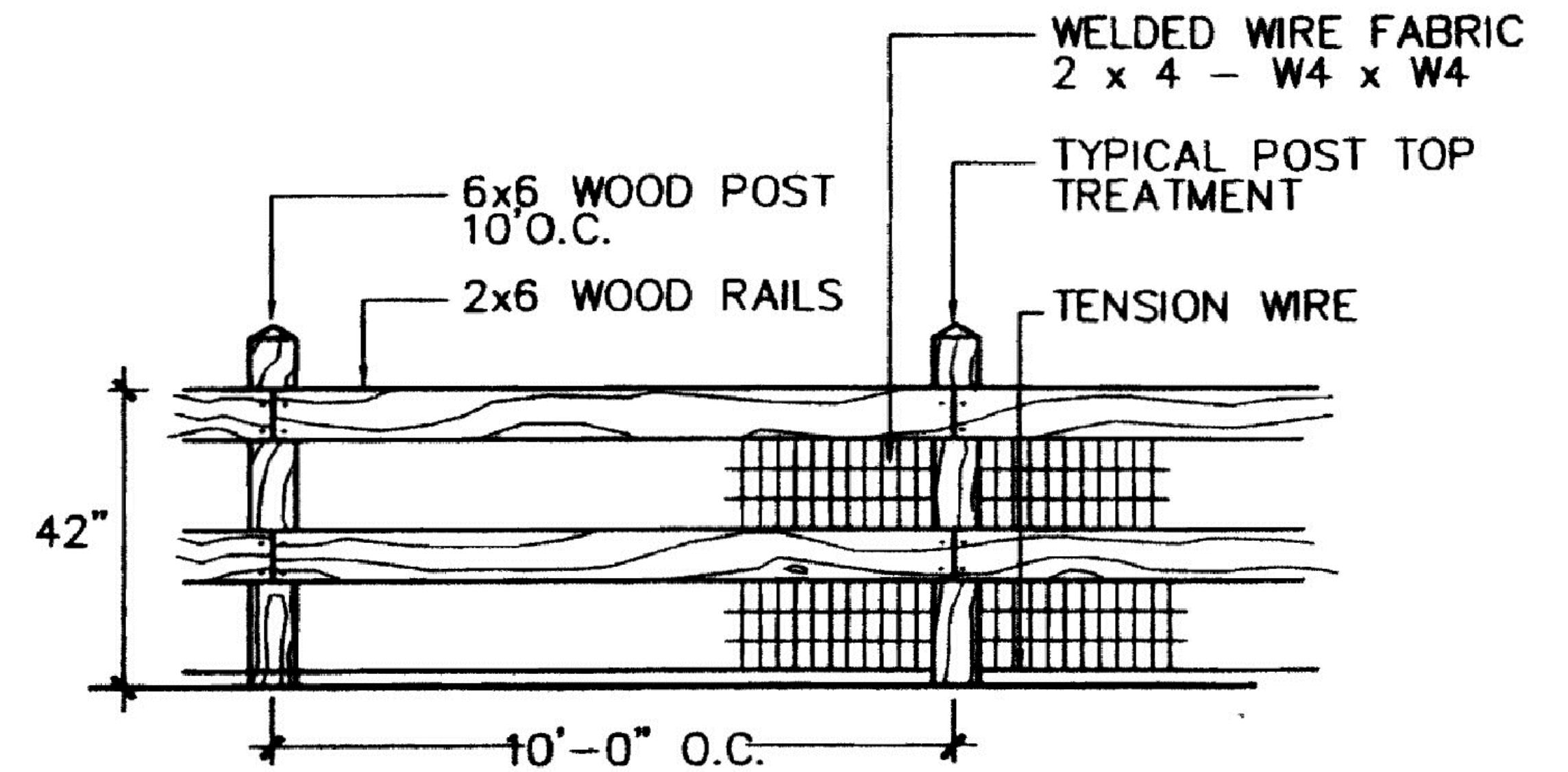

2 2-RAIL FENCE DETAIL
TOWN OF PARKER STANDARD

NOT TO SCALE

COMPARK VILLAGE SOUTH FILING NO. 2 & COMPARK VILLAGE SOUTH FILING NO. 2 - AMENDMENT NO. 1 FINAL LANDSCAPE PLAN - FENCE DETAILS

OWNER
470 Compark, LLC
290 Fillmore St., Suite 2
Denver, CO 80206

LANDSCAPE ARCHITECT
Plan West, Inc.
767 Santa Fe Drive
Denver, CO 80204
(303) 741-1411

Town of Parker
Colorado
job no. 2015-20
date 11-22-2016
revisions 07-05-2017

ENGINEER
Manhard Consulting
8008 E. Arapahoe Ct. Suite 110
Centennial CO 80112
(303) 531-3213

sheet L13 of L14

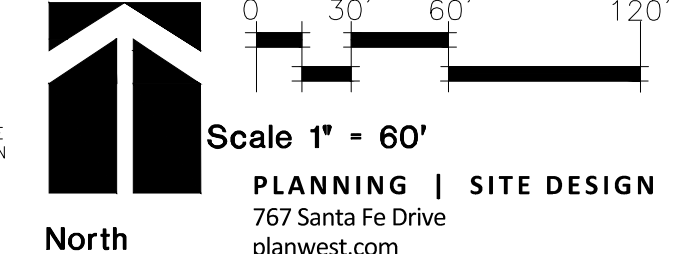

THE REPRODUCTION OF ANY INFORMATION GENERATED BY ARCHITECTS, ENGINEERS OR OTHER CONSULTANTS ON THESE DRAWINGS IS FOR THE EXPRESS PURPOSE OF COORDINATION AND EASE OF REFERENCE ONLY. INCLUSION OF SAID INFORMATION ON THESE DRAWINGS DOES NOT CONSTITUTE A REPRESENTATION BY PLAN WEST AS TO THE SUFFICIENCY OR ACCURACY OF SAID INFORMATION.

PLANNING | SITE DESIGN | LANDSCAPE ARCHITECTURE | ENTITLEMENTS
Denver, Colorado, 80204
303-741-1411
planwest.com

COMPARK VILLAGE SOUTH FILING NO. 2 & COMPARK VILLAGE SOUTH FILING NO. 2 - AMENDMENT NO. 1 FINAL LANDSCAPE PLAN

A PARCEL OF LAND LOCATED IN THE SOUTH HALF OF SECTION 6, TOWNSHIP 6 SOUTH RANGE 66 WEST OF THE SIXTH PRINCIPAL MERIDIAN, TOWN OF PARKER, COUNTY OF DOUGLAS, STATE OF COLORADO
 PLANNING AREA 17 & 18
 32.86 ACRES, 192 RESIDENTIAL UNITS, 20 TRACTS

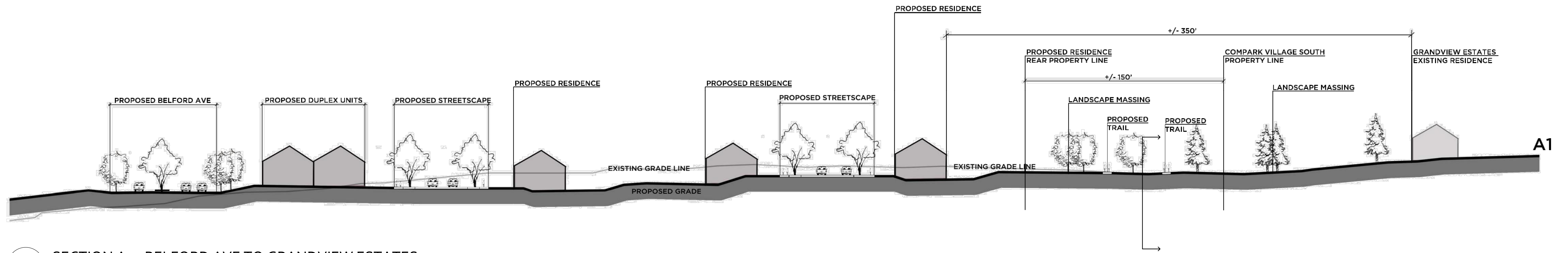

A1 SECTION A1 - BELFORD AVE TO GRANDVIEW ESTATES

SCALE: 1"=40'-0"

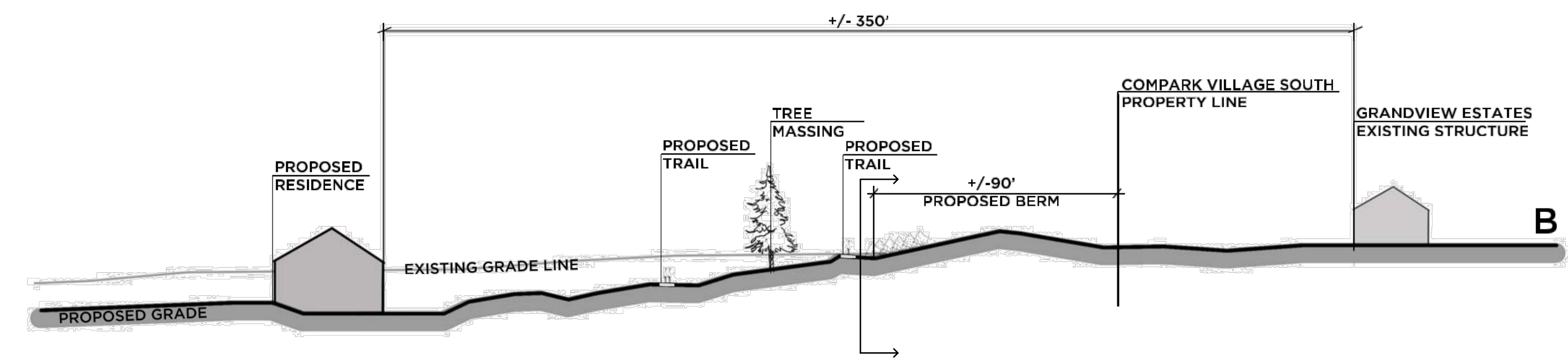

B SECTION B - COMPARK VILLAGE SOUTH PROPOSED RESIDENCE TO GRANDVIEW ESTATES RESIDENCE

SCALE: 1"=40'-0"

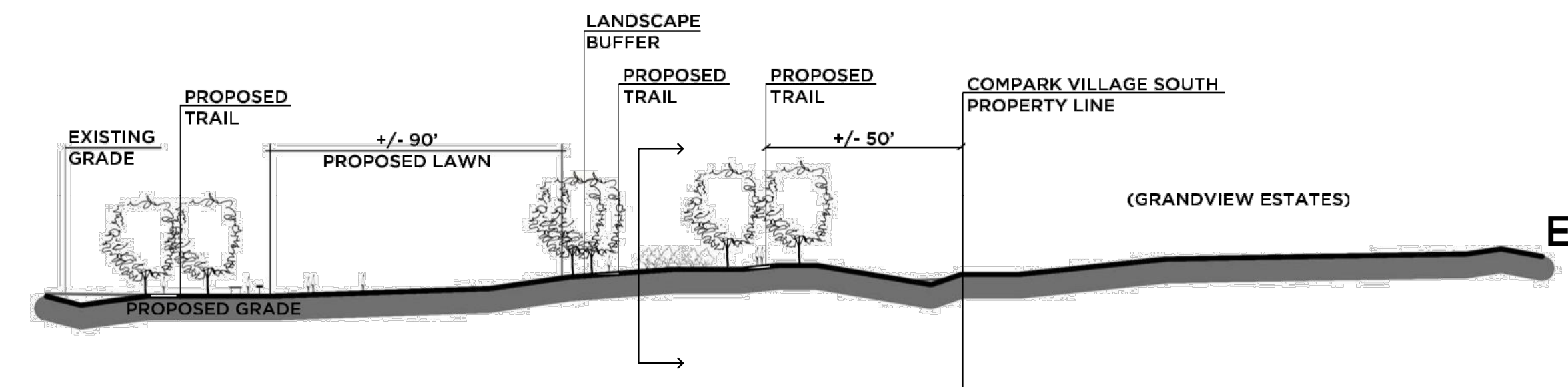

E SECTION E - FROM GRANDVIEW ESTATES TO COMPARK VILLAGE SOUTH PARK

SCALE: 1"=40'-0"

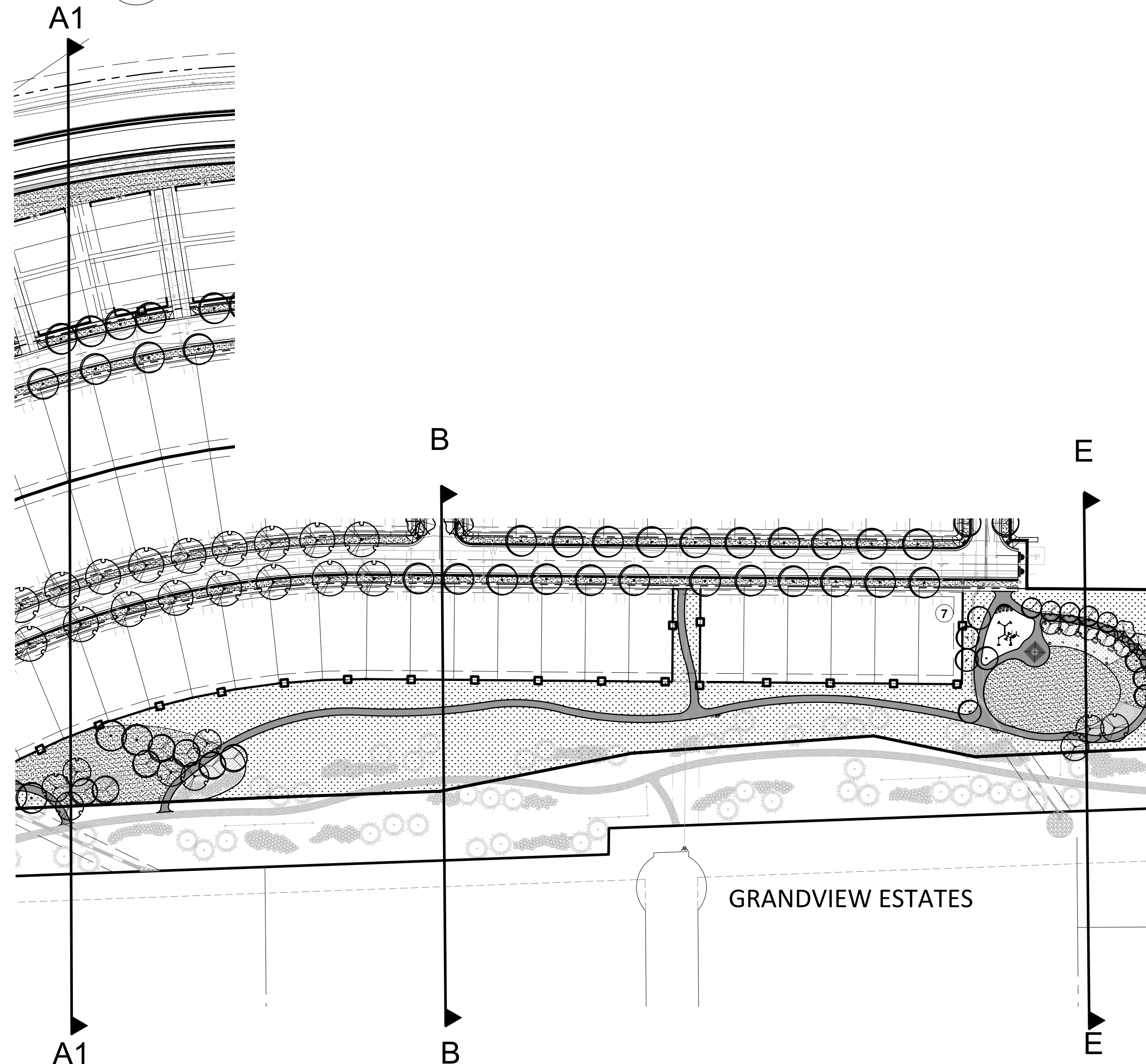

SECTION CUT LINES VICINITY MAP

SCALE: 1"=100'-0"

COMPARK VILLAGE SOUTH FILING NO. 2 & COMPARK VILLAGE SOUTH FILING NO. 2 - AMENDMENT NO. 1 FINAL LANDSCAPE PLAN - SECTIONS

OWNER
 470 Compark, LLC
 290 Fillmore St., Suite 2
 Denver, CO 80206

LANDSCAPE ARCHITECT
 Plan West, Inc.
 767 Santa Fe Drive
 Denver, CO 80204
 (303) 741-1411

Town of Parker
 Colorado

job no. 2015-20
 date 11-22-2016
 revisions 07-05-2017

ENGINEER
 Manhard Consulting
 8008 E. Arapahoe Ct. Suite 110
 Centennial CO 80112
 (303) 531-3213

sheet L14 of L14



THE REPRODUCTION OF ANY INFORMATION GENERATED BY ARCHITECTS, ENGINEERS OR OTHER CONSULTANTS ON THESE DRAWINGS IS FOR THE EXPRESS PURPOSE OF COORDINATION AND AS A REFERENCE ONLY. INCLUSION OF SAID INFORMATION ON THESE DRAWINGS DOES NOT CONSTITUTE A REPRESENTATION BY PLAN WEST AS TO THE SUFFICIENCY OR ACCURACY OF SAID INFORMATION.