

Final Drainage Report

***Compark Village South Filing No. 2 and Filing 2, Amd 1
Parker, Colorado***

Code: CLCPKC3

Prepared For:

Michael Vickers
470 Compark, LLC
290 Fillmore Street, Suite 1A
Denver, Colorado 80206

Prepared By:



7600 East Orchard Road, Suite 150-N
Greenwood Village, Colorado 80111
Contact: Gary T. Iwata, P.E.
303-708-0500

Submitted: November, 2016
Revised: December, 2016
Revised: July 2020

ENGINEERS CERTIFICATION

This Final Drainage Report for Compark Village South Filing No. 2 and Filing No. 2 – Amendment No. 1 was prepared by me or under my direct supervision in accordance with the provisions of the *Town of Parker Storm Drainage and Environmental Criteria Manual*. I understand that the Town of Parker and its designated town authority do not and will not assume liability for drainage facilities designed by others.

Gary T. Iwata, P.E.

Registered Professional Engineer

State of Colorado No. 37642

TABLE OF CONTENTS

I. Introduction	1
A. Location	1
B. Description of Property	1
C. Existing Soils	1
II. Drainage Basins and Sub-Basins	2
A. Existing Basin Description	2
B. Proposed Basin Development	2
C. Sub Basin Descriptions	2
III. Drainage Design Criteria	16
A. Hydrology Criteria	16
B. Hydraulic Criteria	17
IV. Drainage Facility Design	18
A. General Concept	18
B. Specific Details	18
V. Environmental Protection Criteria	19
A. Erosion and Sediment Control Measures	19
B. Water Quality	19
VI. Conclusion	20
A. Compliance with Standards	20
B. Drainage Concept	20
C. Erosion and Sediment Control Concept	20

APPENDICES

APPENDIX A

Maps

- Vicinity Map
- FEMA Flood Information Rate Map
- Soils Map

APPENDIX B

Hydrologic Analysis

- UDFCD Table 6-4
- UDFCD Table 6-5
- UDFCD Figures 6-1, 6-2 & 6-3
- Time of Concentration Calculations
- 2-Year Storm Runoff Calculations
- 100-Year Storm Runoff Calculations

APPENDIX C

Hydraulic Analysis

- Inlet Capacity Calculations
- StormCAD Storm Sewer Design
 - 2-Year Storm Table and Profiles
 - 100-Year Storm Table and Profiles

APPENDIX D

Drainage Basin Map

I. Introduction

A. Location

Compark Village South Filing 2 is located within the south half of section 6, township 6 south, range 66 west of the 6th principal meridian, Town of Parker, Douglas County, Colorado. The site is bound by existing residential neighborhoods to the South, future Belford Ave to the North, and future developed parcels to the East and West.

The Compark Village South Filing 2 developed area is approximately 32.9 acres. Upon final build out, the site will contain 120 residential duplex lots and 72 residential single family home lots.

B. Description of Property

The topography for the site generally slopes from South to North. The highest elevation on the site is located at the southwest quadrant of the site and the lowest elevation is located directly north of Belford Avenue.

Existing vegetation on the site is comprised of native grasses, shrubs and weedy species indigenous to the area.

C. Existing Soils

Existing soils for the site were researched on the NRCS web soil survey, see Appendix A. Three principal soil groups exist onsite:

- Newlin Gravelly Sandy Loam (NeE 8 to 30% slopes) This rolling to steep sloping soil is located on uplands and terrace side slopes. Runoff is medium and erosion hazard is slight to moderate. This soil is classified as a Type B Hydrologic Soil Group.
- Fondis Clay Loam (FoD 3 to 9% slopes) This sloping soil is located on uplands. Runoff is high and the erosion hazard is moderate. The soil is classified as a Type C Hydrologic Soil Group.
- Fondis Clay Loam (FoB 1 to 3% slopes) This gently sloping soil is located on tablelands and uplands. Runoff is medium and erosion hazard is slight to moderate. The soil is classified as a Type C Hydrologic Soil Group.

II. Drainage Basins and Sub-Basins

A. Existing Basin Description

The proposed site is tributary to Green Acres Tributary which runs through the property adjacent to the North of the site. The Green Acres Tributary confluences w/ Happy Canyon Creek upstream of Jordan Road and ultimately joins Cherry Creek, further downstream of Jordan Road. There is an existing 10' x 12' box culvert located to the north of the site that conveys flows from an existing depressed area to the north of the site through and under E-470.

The site is located within Zone X as shown on the Federal Emergency Management Agency (FEMA) Flood Insurance Rate Maps (FIRM) numbers 08035C0062F and 08035C0066F, dated September 30, 2005 for Happy Canyon Creek. The FIRM maps can be found in Appendix A. A portion of the Green Acres Tributary is located in the Zone A 100-year Floodplain, also shown on the FIRM maps in Appendix A.

B. Proposed Basin Development

The proposed site will be divided into several drainage sub-basins. These sub-basins have been determined based on land use, area, roadway slopes, storm sewer locations and inlet capacities. The developed site will generally follow the existing drainage patterns and runoff will be conveyed via storm sewer, overland flow, and channel flow through a proposed channel to a proposed detention and water quality basin located directly north of the site. This detention basin will release restricted flows into an existing box culvert under E-470 and into the Green Acres Tributary in compliance with the Master Drainage Report for Compark Village South and Town of Parker requirements. A portion of the site will drain to two direct discharges to the Green Acres Tributary. Each direct discharge will have a diversion structure before the connection to the GAT. The diversion structure will direct the two-year storm to the proposed detention basin for water quality treatment and will allow the less frequent storms to overtop a diversion weir and flow to the GAT. The Preliminary Drainage Exhibit located in Appendix D shows the location and size of each proposed drainage sub-basin.

C. Sub Basin Descriptions

BEL-1

Drainage basin BEL-1 is composed of landscaped area, sidewalk, and the north half of a portion of Belford Avenue. Storm water will flow east toward Design Point B1 where it will be collected by Inlet 2-1. This is an on grade 10' Type R inlet with the capacity to handle the runoff from a 5 year storm event. From there, storm water will be conveyed to the West Water Quality Pond just southeast of Belford Avenue via storm sewer. This pond discharges directly to Green Acres Tributary. In the 100 year

storm event, excess runoff will bypass Inlet 2-1 and flow into sub basin BEL-3 where it will be intercepted by Inlet 2-2 at Design Point B3.

BEL-2

Drainage basin BEL-2 is composed of landscaped area, sidewalk, and the south half of a portion of Belford Avenue. Storm water will flow east toward Design Point B2 where it will be collected by Inlet 1-1. This is an on grade 10' Type R inlet with the capacity to handle the runoff from a 5 year storm event. From there, storm water will be conveyed to the West Water Quality Pond just southeast of Belford Avenue via storm sewer. This pond discharges directly to Green Acres Tributary. In the 100 year storm event, excess runoff will bypass Inlet 1-1 and flow into sub basin BEL-4 where it will be intercepted by Inlet 1-2 at Design Point B4.

BEL-3

Drainage basin BEL-3 is composed of landscaped area, sidewalk, and the north half of a portion of Belford Avenue. Storm water will flow toward a low point in the middle of the basin at Design Point B3 where it will be collected by Inlet 2-2. This is a 15' Type R inlet in sump with the capacity to handle the runoff from a 100 year storm event for basin BEL-3 as well as the bypass runoff from basin BEL-1. From there, storm water will be conveyed to the East Water Quality Pond just east of Belford Avenue via storm sewer. This pond discharges directly to Green Acres Tributary.

BEL-4

Drainage basin BEL-4 is composed of landscaped area, sidewalk, and the south half of a portion of Belford Avenue. Storm water will flow toward a low point in the middle of the basin at Design Point B4 where it will be collected by Inlet 1-2. This is a 10' Type R inlet in sump with the capacity to handle the runoff from a 100 year storm event for basin BEL-4 as well as the bypass runoff from basin BEL-2. From there, storm water will be conveyed to the East Water Quality Pond just east of Belford Avenue via storm sewer. This pond discharges directly to Green Acres Tributary.

BEL-5

Drainage basin BEL-5 is composed of landscaped area, sidewalk, and the north half of a portion of Belford Avenue. It also includes half of the bridge over Happy Canyon Creek. Storm water will generally flow southeast toward Design Point B5 at South Chambers Road. A storm sewer network has not yet been designed to accommodate this basin. This will be completed in another phase.

BEL-6

Drainage basin BEL-6 is composed of landscaped area, sidewalk, and the south half of a portion of Belford Avenue. It also includes half of the bridge over Happy Canyon

Creek. Storm water will generally flow southeast toward Design Point B6 at South Chambers Road. A storm sewer network has not yet been designed to accommodate this basin. This will be completed in another phase.

CVS-1

Drainage basin CVS-1 is composed of landscaped area, sidewalk, and the north half of a portion of Belford Avenue. Storm water will flow northeast toward Design Point 1 where it will be intercepted by Inlet 1-3. This is an on grade 15' Type R inlet with the capacity to handle the runoff from a 5 year storm event. From there, storm water will be conveyed directly to Green Acres Tributary via storm sewer. A water quality structure will be installed just before the outfall into Green Acres Tributary as part of the Compark Village South Filing No. 1 project. In the 100 year storm event, excess runoff will bypass Inlet 1-3 and flow into sub basin CVS-3 where it will be intercepted by Inlet 1-4 at Design Point 3.

CVS-2

Drainage basin CVS-2 is composed of landscaped area, sidewalk, and the south half of a portion of Belford Avenue. Storm water will flow northeast toward Design Point 2 where it will be intercepted by Inlet 2-3. This is an on grade 15' Type R inlet with the capacity to handle the runoff from a 5 year storm event. From there, storm water will be conveyed directly to Green Acres Tributary via storm sewer. In the 100 year storm event, excess runoff will bypass Inlet 2-3 and flow into sub basin CVS-4 where it will be intercepted by Inlet 2-4 at Design Point 4.

CVS-3

Drainage basin CVS-3 is composed of landscaped area, sidewalk, and the north half of a portion of Belford Avenue. Storm water will flow northeast toward Design Point 3 where it will be collected by Inlet 1-4. This is an on grade 10' Type R inlet with the capacity to handle the runoff from a 5 year storm event. From there, storm water will be conveyed directly to Green Acres Tributary via storm sewer. A diversion structure will be installed just before the outfall into Green Acres Tributary as part of the Compark Village South Filing No. 1 project. The diversion structure is designed to direct the runoff from a two year storm event to the proposed full spectrum detention basin to be installed as part of the Compark Village South Filing No. 1 project. In less frequent storm events, the runoff will overtop the diversion weir and discharge directly to the Green Acres Tributary. In the 100 year storm event, excess runoff will bypass Inlet 2-3 and flow into sub basin CVS-7 where it will be intercepted by Inlet 1-6 at Design Point 7.

CVS-4

Drainage basin CVS-4 is composed of landscaped area, sidewalk, and the south half of a portion of Belford Avenue. Storm water will flow northeast toward Design Point 4

where it will be collected by Inlet 2-4. This is an on grade 15' Type R inlet with the capacity to handle the runoff from a 5 year storm event. From there, storm water will be conveyed directly to Green Acres Tributary via storm sewer. A diversion structure will be installed before the outfall into Green Acres Tributary as part of the Compark Village South Filing No. 1 project. The diversion structure is designed to direct the runoff from a two year storm event to the proposed full spectrum detention basin to be installed as part of the Compark Village South Filing No. 1 project. In less frequent storm events, the runoff will overtop the diversion weir and discharge directly to the Green Acres Tributary. In the 100 year storm event, excess runoff will bypass Inlet 2-4 and flow into sub basin CVS-8 where it will be intercepted by Inlet 2-6 at Design Point 8.

CVS-4A

Drainage basin CVS-4 is composed of landscaped area, sidewalk, residential homes, and residential local streets. Storm water will flow northeast toward Design Point 4A where it will be collected by Inlet 3-4. This is a 10' Type R inlet in sump with the capacity to handle the runoff from a 100 year storm event for basin CVS-4A as well as the bypass runoff from basin CVS-5. From there, it will be conveyed via storm sewer to the diversion structure described above and then either to the detention basin or directly to Green Acres Tributary via storm sewer.

CVS-5

Drainage basin CVS-5 is composed of landscaped area, sidewalk, residential homes and residential local streets. Storm water will flow northeast toward Design Point 5 where it will be collected by Inlet 5-4. This is an on grade 15' Type R inlet with the capacity to handle the runoff from a 2 year storm event. From there, it will be conveyed via storm sewer to the diversion structure described above and then either to the detention basin or directly to Green Acres Tributary via storm sewer. In the 100 year storm event, excess runoff will bypass Inlet 5-4 and flow into sub basin CVS-4A where it will be intercepted by Inlet 3-4 at Design Point 4A.

CVS-6

Drainage basin CVS-6 is composed of landscaped area, a berm, sidewalk, and residential local streets. Storm water will flow north toward Design Point 6 where it will be collected by Inlet 6-4. This is an on grade 10' Type R inlet with the capacity to handle the runoff from a 100 year storm event. From there, it will be conveyed via storm sewer to the diversion structure described above and then either to the detention basin or directly to Green Acres Tributary via storm sewer.

CVS-7

Drainage basin CVS-7 is composed of landscaped area, sidewalk, and the north half of a portion of Belford Avenue. Storm water will flow east toward Design Point 7

where it will be collected by Inlet 1-6. This is an on grade 10' Type R inlet with the capacity to handle the runoff from a 5 year storm event. From there, storm water will be conveyed directly to Green Acres Tributary via storm sewer. A diversion structure will be installed just before the outfall into Green Acres Tributary as part of the Compark Village South Filing No. 1 project. The diversion structure is designed to direct the runoff from a two year storm event to the proposed full spectrum detention basin to be installed as part of the Compark Village South Filing No. 1 project. In less frequent storm events, the runoff will overtop the diversion weir and discharge directly to the Green Acres Tributary. In the 100 year storm event, excess runoff will bypass Inlet 5-4 and flow into sub basin CVS-11 where it will be intercepted by Inlet 1-5 at Design Point 11.

CVS-8

Drainage basin CVS-8 is composed of landscaped area, sidewalk, and the south half of a portion of Belford Avenue. Storm water will flow east toward Design Point 8 where it will be intercepted by Inlet 2-6. This is an on grade 15' Type R inlet with the capacity to handle the runoff from a 5 year storm event. From there, it will be conveyed via storm sewer to the diversion structure described above and then either to the detention basin or directly to Green Acres Tributary via storm sewer. In the 100 year storm event, excess runoff will bypass Inlet 2-6 and flow into sub basin CVS-12 where it will be intercepted by Inlet 2-5 at Design Point 12.

CVS-9

Drainage basin CVS-9 is composed of landscaped area, sidewalk, residential homes and residential local streets. Storm water will flow northeast toward Design Point 9 where it will be collected by Inlet 4-5A. This is an on grade 15' Type R inlet with the capacity to handle the runoff from a 2 year storm event. From there, it will be conveyed via storm sewer to the diversion structure described above and then either to the detention basin or directly to Green Acres Tributary via storm sewer. In the 100 year storm event, excess runoff will bypass Inlet 4-5A and flow into sub basin CVS-12 where it will be intercepted by Inlet 2-5 at Design Point 12.

CVS-9A

Drainage basin CVS-9A is composed of landscaped area, sidewalk, residential homes and residential local streets. Storm water will generally flow northwest toward Design Point 9A where it will be collected by Inlet 4-4. This is a 5' Type R inlet in sump with the capacity to handle the runoff from a 100 year storm event. From there, it will be conveyed via storm sewer to the diversion structure described above and then either to the detention basin or directly to Green Acres Tributary via storm sewer.

CVS-10

Drainage basin CVS-10 is composed of landscaped area, sidewalk, residential homes and residential local streets. Storm water will flow northeast toward Design Point 10 where it will be collected by Inlet 5-5A. This is an on grade 15' Type R inlet with the capacity to handle the runoff from a 2 year storm event. From there, it will be conveyed via storm sewer to the diversion structure described above and then either to the detention basin or directly to Green Acres Tributary via storm sewer. In the 100 year storm event, excess runoff will bypass Inlet 5-5A and flow into sub basin CVS-13B where it will be intercepted by Inlet 4-5B at Design Point 13B.

CVS-10A

Drainage basin CVS-10A is composed of landscaped area, sidewalk, residential homes and residential local streets. Storm water will generally flow northwest toward Design Point 10A where it will be collected by Inlet 5-4A. This is a 5' Type R inlet on grade with the capacity to handle the runoff from a 2 year storm event. From there, it will be conveyed via storm sewer to the diversion structure described above and then either to the detention basin or directly to Green Acres Tributary via storm sewer. In the 100 year storm event, excess runoff will bypass Inlet 5-4A and flow into sub basin CVS-10 where it will be intercepted by Inlet 5-5A at Design Point 10.

CVS-11

Drainage basin CVS-11 is composed of landscaped area, sidewalk, and the north half of a portion of Belford Avenue. Storm water will flow toward a low point in the middle of the basin at Design Point 11 where it will be collected by Inlet 1-5. This is a 10' Type R inlet in sump with the capacity to handle the runoff from a 100 year storm event for basin CVS-11 as well as the bypass runoff from basin CVS-7. From there, storm water will be conveyed to the regional detention pond at E-470 via storm sewer. This pond discharges directly to Green Acres Tributary.

CVS-12

Drainage basin CVS-12 is composed of landscaped area, sidewalk, residential homes, residential local streets, and the south half of a portion of Belford Avenue. Storm water will flow toward a low point in the middle of the north side of the basin at Design Point 12 where it will be collected by Inlet 2-5. This is a 15' Type R inlet in sump with the capacity to handle the runoff from a 100 year storm event for basin CVS-12 as well as the bypass runoff from basins CVS-8 and CVS-9. From there, storm water will be conveyed to the CVS Filing No. 1 detention basin at E-470 via storm sewer. This basin discharges directly to Green Acres Tributary.

CVS-12A

Drainage basin CVS-12A is composed of landscaped area, sidewalk, residential homes and residential local streets. Storm water will flow south and east toward Design Point 12A where it will be collected by Inlet 3-5. This is a 15' Type R inlet in sump with the capacity to handle the runoff from a 100 year storm event. From there, storm water will be conveyed to the CVS Filing No. 1 detention basin at E-470 via storm sewer. This basin discharges directly to Green Acres Tributary.

CVS-12B

Drainage basin CVS-12B is composed of landscaped area, sidewalk, residential homes and residential local streets. Storm water will generally flow south and west toward Design Point 12A where it will be collected by Inlet 3-5. This is a 15' Type R inlet in sump with the capacity to handle the runoff from a 100 year storm event. From there, storm water will be conveyed to the CVS Filing No. 1 detention basin at E-470 via storm sewer. This basin discharges directly to Green Acres Tributary.

CVS-13

Drainage basin CVS-13 is composed of landscaped area, sidewalk, residential homes and residential local streets. Storm water will flow northeast toward Design Point 13 where it will be collected by Inlet 4-5. This is a 10' Type R inlet in sump with the capacity to handle the runoff from a 100 year storm event as well as the bypass runoff from basin CVS-13C. From there, storm water will be conveyed to the CVS Filing No. 1 detention basin at E-470 via storm sewer. This basin discharges directly to Green Acres Tributary.

CVS-13A

Drainage basin CVS-13A is composed of landscaped area, sidewalk, residential homes and residential local streets. Storm water will flow east and north toward Design Point 13A where it will be collected by Inlet 6-5A. This is a 10' Type R inlet on grade with the capacity to handle the runoff from a 2 year storm event. From there, storm water will be conveyed to the CVS Filing No. 1 detention basin at E-470 via storm sewer. This basin discharges directly to Green Acres Tributary. In the 100 year storm event, excess runoff will bypass Inlet 6-5A and flow into sub basin CVS-13 where it will be intercepted by Inlet 4-5 at Design Point 13.

CVS-13B

Drainage basin CVS-13B is composed of landscaped area, sidewalk, residential homes and residential local streets. Storm water will flow east and north toward Design Point 13B where it will be collected by Inlet 4-5B. This is a 10' Type R inlet on grade with the capacity to handle the runoff from a 2 year storm event. From there, storm water will be conveyed to the CVS Filing No. 1 detention basin at E-470 via

storm sewer. This basin discharges directly to Green Acres Tributary. In the 100 year storm event, excess runoff will bypass Inlet 4-5B and flow into sub basin CVS-13C where it will be intercepted by Inlet 4-5C at Design Point 13C.

CVS-13C

Drainage basin CVS-13C is composed of landscaped area, sidewalk, residential homes and residential local streets. Storm water will flow north and east toward Design Point 13C where it will be collected by Inlet 4-5C. This is a 5' Type R inlet on grade with the capacity to handle the runoff from a 2 year storm event. From there, storm water will be conveyed to the regional detention pond at E-470 via storm sewer. This pond discharges directly to Green Acres Tributary. In the 100 year storm event, excess runoff will bypass Inlet 4-5C and flow into sub basin CVS-13 where it will be intercepted by Inlet 4-5 Design Point 13.

CVS-14

Drainage basin CVS-14 is composed of landscaped area, sidewalk, residential homes and residential local streets. Storm water will flow north and east toward Design Point 14 where it will be collected by Inlet 6-5. This is a 15' Type R inlet in sump with the capacity to handle the runoff from a 100 year storm event including runoff from basin CVS-14B and bypass runoff from basin CVS-14C. From there, storm water will be conveyed to the CVS Filing No. 1 detention basin at E-470 via storm sewer. This basin discharges directly to Green Acres Tributary.

CVS-14A

Drainage basin CVS-14A is composed of landscaped area and berms. Runoff will flow toward a swale along the north side of the basin. The swale will send the storm water east toward Design Point 14A where it will be collected by Inlet 7-5. This is a CDOT Type C inlet with the capacity to handle the runoff from a 100 year storm event. From there, storm water will be conveyed to the regional detention pond at E-470 via storm sewer. This pond discharges directly to Green Acres Tributary.

CVS-14B

Drainage basin CVS-14 is composed of landscaped area, future sidewalk, some future residential homes and future residential local streets. Storm water will north and east flow toward Design Point 14 where it will be collected by Inlet 6-5. This is a 15' Type R inlet in sump with the capacity to handle the runoff from a 100 year storm event including runoff from basin CVS-14. From there, storm water will be conveyed to the CVS Filing No. 1 detention basin at E-470 via storm sewer. This basin discharges directly to Green Acres Tributary.

CVS-14C

Drainage basin CVS-14C is composed of landscaped area, sidewalk, residential homes and residential local streets. Storm water will flow north and east toward Design Point 14C where it will be collected by Inlet 5-5B. This is a 10' Type R inlet on grade with the capacity to handle the runoff from a 2 year storm event. From there, storm water will be conveyed to the CVS Filing No. 1 detention basin at E-470 via storm sewer. This basin discharges directly to Green Acres Tributary. In the 100 year storm event, excess runoff will bypass Inlet 5-5B and flow into sub basin CVS-14 where it will be intercepted by Inlet 6-5 at Design Point 14.

CVS-15

Drainage basin CVS-15 is to be developed in a later phase and will be composed of landscaped area, sidewalk, residential homes and residential local streets. Storm water will flow north and west toward Design Point 15 where it will be collected by Inlet 5-5. This is a 10' Type R inlet in sump with the capacity to handle the runoff from a 100 year storm event as well as bypass runoff from Basin CVS-15A. From there, storm water will be conveyed to the CVS Filing No. 1 detention basin at E-470 via storm sewer. This basin discharges directly to Green Acres Tributary.

CVS-15A

Drainage basin CVS-15A is to be developed in a later phase and will be composed of landscaped area, sidewalk, residential homes and residential local streets. Storm water will flow west and north toward Design Point 15A where it will be collected by Inlet 6-5B. This is a 10' Type R inlet on grade with the capacity to handle the runoff from a 2 year storm event. From there, storm water will be conveyed to the CVS Filing No. 1 detention basin at E-470 via storm sewer. This basin discharges directly to Green Acres Tributary. In the 100 year storm event, excess runoff will bypass Inlet 6-5B and flow into sub basin CVS-15 where it will be intercepted by Inlet 5-5 at Design Point 15.

CVS-16

Drainage basin CVS-16 is composed of landscaped area, sidewalk, residential homes and residential local streets. Storm water will flow southeast toward Design Point 16 where it will be collected by Inlet 2-11A. This is a 10' Type R inlet on grade with the capacity to handle the runoff from a 2 year storm event. From there, storm water will be conveyed to the CVS Filing No. 1 detention basin at E-470 via storm sewer and a temporary drainage swale. This detention basin discharges directly to Green Acres Tributary. In the 100 year storm event, excess runoff will bypass Inlet 2-11A and flow east across Wolf Fox Street via a concrete pan to Inlet 2-10A at Design Point 22.

CVS-17

Drainage basin CVS-17 is to be developed in a later phase and will be composed of landscaped area, sidewalk, residential homes and residential local streets. Storm water will flow northeast toward Design Point 17 where it will be collected by Inlet 2-11. This is a 10' Type R inlet on grade with the capacity to handle the runoff from a 2 year storm event. From there, storm water will be conveyed to the CVS Filing No. 1 detention basin at E-470 via storm sewer and a temporary drainage swale. This detention basin discharges directly to Green Acres Tributary. In the 100 year storm event, excess runoff will bypass Inlet 2-11 and flow east across Wolf Fox Street via a concrete pan to Inlet 2-10 at Design Point 23.

CVS-17-A

Drainage basin CVS-17A is to be developed in a later phase and will be composed of landscaped area, sidewalk, residential homes and residential local streets. Storm water will flow northeast toward Design Point 17A. A storm sewer network has not yet been designed to accommodate this basin. This will be completed as part of a later phase.

CVS-18

Drainage basin CVS-18 is to be developed in a later phase and will be composed of landscaped area, sidewalk, and residential local streets. Storm water will flow northeast toward Design Point 18. A storm sewer network has not yet been designed to accommodate this basin. This will be completed as part of a later phase.

CVS-19

Drainage basin CVS-19 is to be developed in a later phase and will be composed of landscaped area, sidewalk, residential homes, residential local streets, and the south half of a portion of Belford Avenue. Storm water will flow northeast toward Design Point 19. A storm sewer network has not yet been designed to accommodate this basin. This will be completed as part of a later phase.

CVS-20

Drainage basin CVS-20 is to be developed in a later phase and will be composed of landscaped area, sidewalk, residential homes, and residential local streets. Storm water will flow southwest and then northwest toward Design Point 20. A storm sewer network has not yet been designed to accommodate this basin. This will be completed as part of a later phase.

CVS-21

Drainage basin CVS-21 is to be developed in a later phase and will be composed of landscaped area, sidewalk, residential homes, and residential local streets. Storm

water will flow north east toward Design Point 21. A storm sewer network has not yet been designed to accommodate this basin. This will be completed as part of a later phase.

CVS-22

Drainage basin CVS-22 is composed of landscaped area, sidewalk, residential homes and residential local streets. Storm water will flow southeast toward Design Point 22 where it will be collected by Inlet 2-10A. This is a 10' Type R inlet on grade with the capacity to handle the runoff from a 100 year storm event. From there, storm water will be conveyed to the CVS Filing No. 1 detention basin at E-470 via storm sewer and a temporary drainage swale. This detention basin discharges directly to Green Acres Tributary.

CVS-23

Drainage basin CVS-23 is to be developed in a later phase and will be composed of landscaped area, sidewalk, residential homes and residential local streets. Storm water will flow northeast toward Design Point 23 where it will be collected by Inlet 2-10. This is a 15' Type R inlet on grade with the capacity to handle the runoff from a 100 year storm event. From there, storm water will be conveyed to the CVS Filing No. 1 detention basin at E-470 via storm sewer and a temporary drainage swale. This detention basin discharges directly to Green Acres Tributary.

III. Drainage Design Criteria

A. Hydrology Criteria

The Town of Parker *Storm Drainage and Environmental Criteria Manual* and the Urban Drainage and Flood Control District (UDFCD) *Urban Storm Drainage Criteria Manual* were used for the storm drainage system design.

The following criteria was utilized in developing the proposed drainage system:

- The proposed drainage system is designed to match, as best as possible, the historic drainage patterns occurring at the site.
- The proposed drainage system attempts to limit the diversion of storm runoff from one basin to another (basin transfer).
- Runoff generated from drainage sub-basins is conveyed via the proposed storm sewer system, overland flow or via the Green Acres Tributary into the proposed regional detention and water quality pond.

Design Rainfall: UDFCD rainfall data is used to determine peak runoff values. The 2-year and 100-year frequency storms are used as the minor and major design storms respectively.

Runoff Calculation: Peak storm runoff is determined using the rational formula,

$$Q = CIA \text{ (CFS)}$$

C = Runoff coefficient based on surface impermeability

I = Rainfall intensity in inches per hour

A = Drainage basin area in acres

UDFCD Imperviousness Values (Table 6-3) and Runoff Coefficients (Table 6-5) were used to develop basin runoff coefficients. These tables can be found in Appendix B. The runoff coefficients are weighted for each applicable sub-basin to more accurately reflect the runoff characteristics of the site.

Time of Concentration is determined using the criteria in Sections 3.4.1 and 3.4.2 of the UDFCD Criteria Manual. These calculations are included in Appendix B.

Rainfall intensities are determined using the Town of Parker's *Storm Drainage and Environmental Criteria Manual* Point Rainfall data and Intensity-Duration curves.

The recurrence intervals used for this study were based on a residential land use. The minor drainage system is designed for a 2-year recurrence interval and the major drainage system is designed for a 100-year recurrence interval.

B. Hydraulic Criteria

The following criteria were utilized in determining allowable street flow.

Minor Storm (2-yr)

- Local Street – No curb overtopping and flow may spread to crown of street.

Minor Storm (5-yr)

- Collector Street – No curb overtopping. Flow Spread must leave at least a 10 foot width free of water. (5-feet on each side of crown for roads without median. 10-feet on each side of median for roads with a median.)

Major Storm (100-yr)

- Local and Collector Streets – The depth of water at the gutter flowline shall not exceed 12 inches. A minimum of 18-inches must be provided from the water surface elevation to the lowest floor elevation or window well opening elevation

for structures that are adjacent to the roadway (this includes residential dwellings, public, commercial and industrial buildings).

For the major and minor storm events, allowable capacity was determined using Street and Inlet Hydraulics version 3.14 by UDFCD.

IV. Drainage Facility Design

A. General Concept

Stormwater runoff from the proposed subdivision will generally follow existing drainage patterns from southwest to northeast on the site. Overland flow and a proposed storm sewer system will route the runoff to the Green Acres Tributary or directly to the proposed full spectrum detention basin located adjacent to the Green Acres Tributary at E-470. This detention basin will release restricted flows directly into the Green Acres Tributary which will then flow through the existing 10' x 12' box culvert under E-470.

B. Specific Details

As mentioned previously in this report, the site will be divided into several drainage sub-basins. The onsite runoff will be routed through the site via the proposed roadways and gutters where it will be intercepted by a number of on-grade inlets and inlets located in roadway sumps. This runoff will be routed, via storm sewer, to either the Green Acres Tributary or directly to the proposed full spectrum detention basin. Existing diversion structures from the Compark Village South, Filing 1 project will direct runoff from the 2-year storm event to the detention basin for treatment before entering the Green Acres Tributary. Flows greater than the 2-year storm will discharge directly to the Green Acres Tributary.

In addition to the onsite sub-basins, the runoff from some offsite areas will be routed through the proposed site. These offsite areas are two basins (H170 & H180) directly south of the site that include part of the Grand View Estates development. In each basin, flows are intercepted via proposed flared end sections and carried through the site via proposed storm sewer into either the Green Acres Tributary or directly into the Compark Village South Filing No. 1 detention basin at E-470.

The Compark Village South Filing No. 1 detention basin was designed based on a study of major basins that all discharge to the Green Acres Tributary. As has been stated, smaller sub basins were created for this report to more accurately design the storm sewer network that serves the Compark Village South Filing 2 and Filing 2, Amendment 1 residential development. To verify coordination between these two sets of data, a table has been provided below.

Basin ID	Impervious % used in GAT Hydrology Study	Composite Impervious % of Corresponding Sub Basins
H161	50%	41%
H171	50%	44%
H181	50%	38%

The corresponding composite impervious percentages from the sub basin analysis are all below the percentages used to design the CVSF 1 detention basin. Therefore, the detention basin has been sufficiently designed to exceed the storage requirements for the Compark Village South Filing 2 and Filing 2, Amd 1 residential sites.

More details for the proposed detention and water quality basin are included in the Conceptual Drainage Report for Compark South prepared by Manhard Consulting, Ltd.^[5] and approved by the Town of Parker.

V. Environmental Protection Criteria

A. Erosion and Sediment Control Measures

During construction, silt fence, inlet protection, and vehicle tracking pads will be used to prevent sediment from entering the storm sewer system or sediment leaving the site. Temporary sediment basins will also be used during construction to trap sediment from stormwater before it leaves the site. All erosion and sediment control measures will be maintained, inspected, and repaired by the Contractor throughout construction in compliance with Town of Parker requirements. The proposed Construction Best Management Practices (CBMPs) for this development will follow the requirements for the Town of Parker and UDFCD.

B. Water Quality

Water quality control for this development will be constructed as part of the Compark Village South Filing 1 project. This will consist of diversion structures on the storm mains that drain to the Green Acres Tributary. The diversion structures will direct runoff from the 2-year storm event to the detention basin for treatment before entering the Green Acres Tributary. Flows greater than the 2-year storm will discharge directly to the Green Acres Tributary.

VI. Conclusion

A. Compliance with Standards

The drainage system for Compark Village South Filing No. 2 and Filing No. 2, Amendment 1 was designed to meet the Town of Parker's *Storm Drainage and Environmental Criteria Manual* and the Urban Drainage and Flood Control District's *Urban Storm Drainage Criteria Manual*. The existing Flood Insurance Rate Map (FIRM) in Appendix A shows no portion of the developed site area to be within a flood hazard area. Therefore, no map revisions through FEMA are required as part of this development.

B. Drainage Concept

The drainage system was designed to allow storm water to be safely conveyed through and away from the site without negatively impacting downstream properties. The drainage concepts proposed for this site are in accordance with the Conceptual Drainage Report for Compark South prepared by Manhard Consulting, Ltd. and approved by the Town of Parker.

All storm sewer facilities are intended to be included within the Town of Parker's public improvements maintenance program. The Compark South Drainage Channel Tract will be owned and maintained by the Belford South Metropolitan District. The Town of Parker will retain oversight maintenance rights as needed during emergency conditions.

C. Erosion and Sediment Control Concept

The Construction Best Management Practices (CBMPs) proposed for this site follow the requirements of the Town of Parker and the recommendations by UDFCD. Attention to proper installation and maintenance are essential for the sediment and erosion control practices to function properly.

VII. References

1. Town of Parker's *Storm Drainage and Environmental Criteria Manual*, February 2014.
2. Urban Drainage and Flood Control District's *Urban Storm Drainage Criteria Manual* Vol. 1–2, dated April, 2008.
3. Urban Drainage and Flood Control District's *Urban Storm Drainage Criteria Manual* Vol. 3, dated November, 2010.
4. StormCAD, V8i (SELECT series 2), Bentley Systems, Inc., c. 2011 Bentley Systems, Inc.
5. Conceptual Drainage Report for Compark South, prepared by Manhard Consulting, Ltd., dated November 20, 2015.
6. Happy Canyon Creek Major Drainageway Plan, prepared by Muller Engineering Company, Inc., dated March 2014
7. Final Drainage Report for Compark Village South, Filing No. 1, prepared by Manhard Consulting Ltd., dated December 20, 2016

APPENDIX A

Maps

- Vicinity Map
- FEMA Flood Information Rate Map
- Soils Map

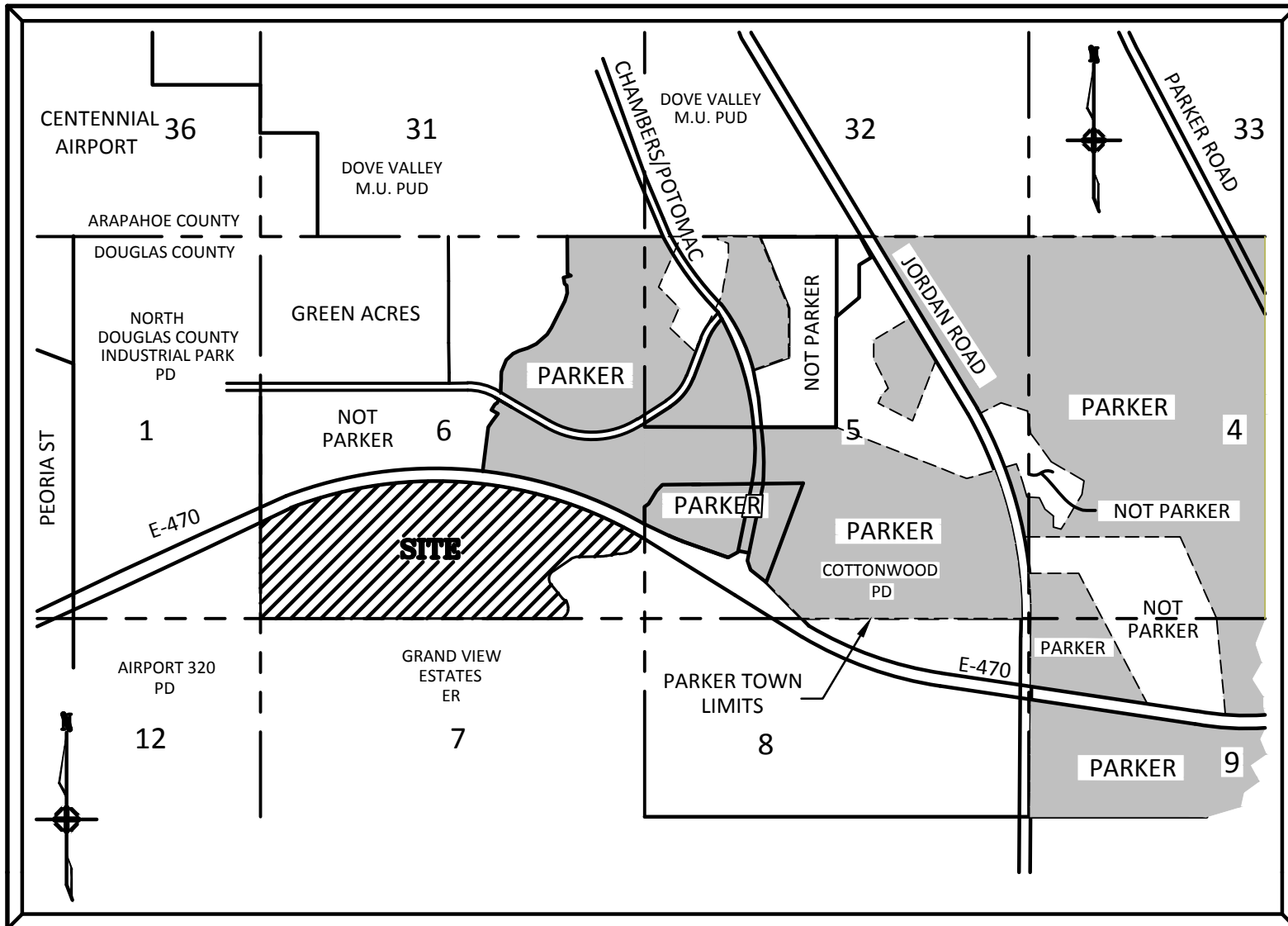

VICINITY MAP

N.T.S.

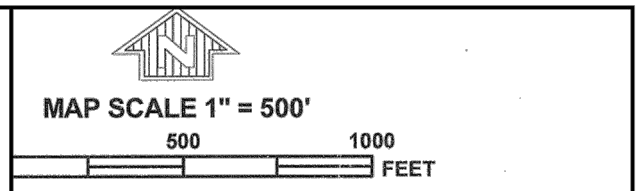
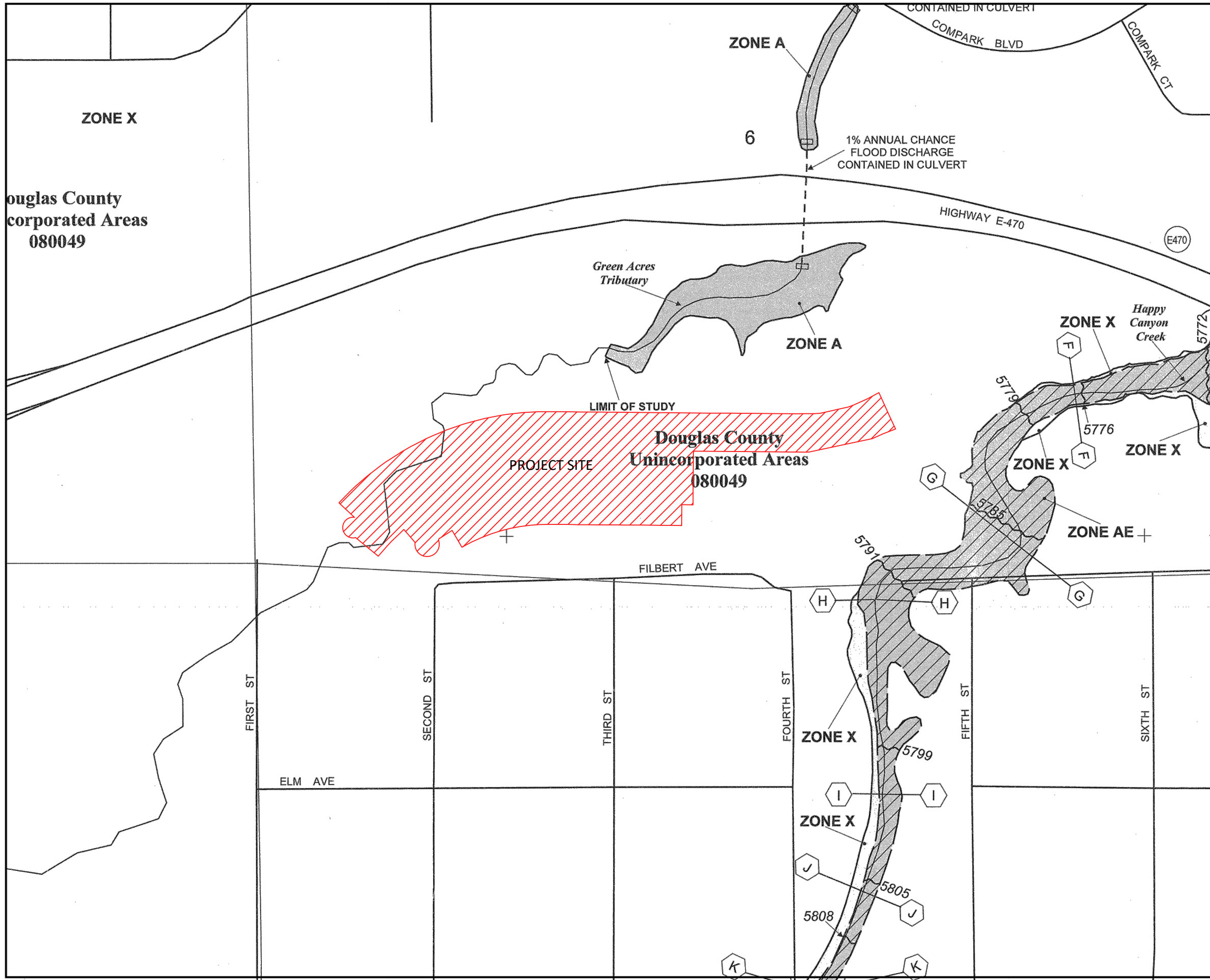

PANEL 0062F

FIRM
FLOOD INSURANCE RATE MAP
DOUGLAS COUNTY,
COLORADO
AND INCORPORATED AREAS

PANEL 62 OF 495
(SEE MAP INDEX FOR FIRM PANEL LAYOUT)

CONTAINS

COMMUNITY	NUMBER	PANEL	SUFFIX
DOUGLAS COUNTY	080049	0062	F
LONE TREE, CITY OF	080319	0062	F

Notice to User: The Map Number shown below should be used when placing map orders; the Community Number shown above should be used on insurance applications for the subject community.



MAP NUMBER
08035C0062F
EFFECTIVE DATE:
SEPTEMBER 30, 2005

Federal Emergency Management Agency

This is an official copy of a portion of the above referenced flood map. It was extracted using F-MIT On-Line. This map does not reflect changes or amendments which may have been made subsequent to the date on the title block. For the latest product information about National Flood Insurance Program flood maps check the FEMA Flood Map Store at www.msc.fema.gov

11:25 D:\a\Name: P:\Clc\pkc3\ComSouth05-Residential_Preliminary_Plot\Documents\Engineering\StormWater_Reports\Preliminary_Report\Soil_Map_Exhibit.dwg Updated By: rkatz

Soil Map—Castle Rock Area, Colorado

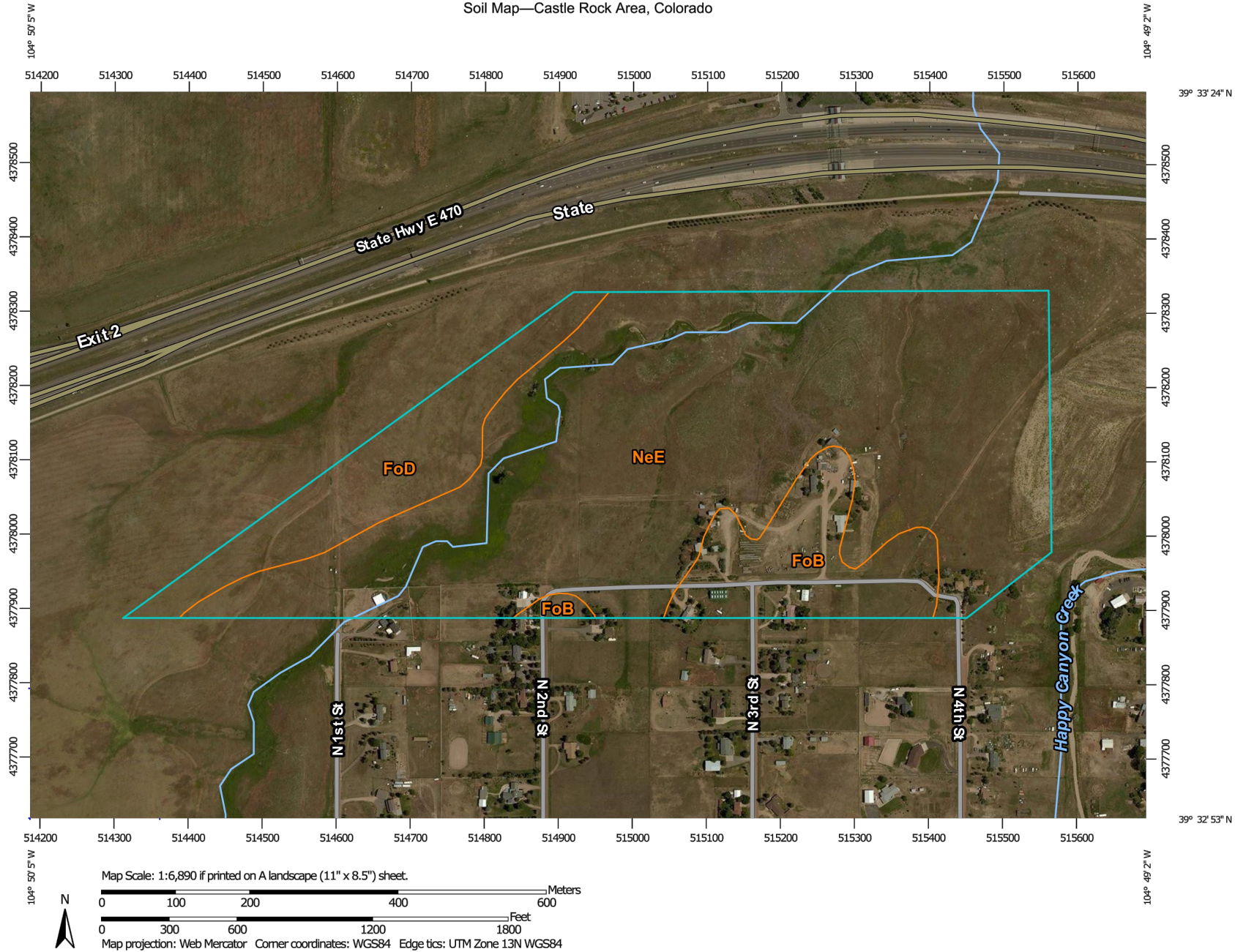

 **Natural Resources Conservation Service**

Web Soil Survey
National Cooperative Soil Survey

1/14/2016
Page 1 of 3







































COMPARK VILLAGE SOUTH FILING NO. 1
TOWN OF PARKER, CO
SOIL MAP EXHIBIT

RJM
RAK
1/14/16
1:6,890
SHEET
1
CLCPKC3

© 2015 MANHARD CONSULTING, LTD. ALL RIGHTS RESERVED

MAP LEGEND

- Area of Interest (AOI)**
-  Area of Interest (AOI)
- Soils**
-  Soil Map Unit Polygons
-  Soil Map Unit Lines
-  Soil Map Unit Points
- Special Point Features**
-  Blowout
-  Borrow Pit
-  Clay Spot
-  Closed Depression
-  Gravel Pit
-  Gravelly Spot
-  Landfill
-  Lava Flow
-  Marsh or swamp
-  Mine or Quarry
-  Miscellaneous Water
-  Perennial Water
-  Rock Outcrop
-  Saline Spot
-  Sandy Spot
-  Severely Eroded Spot
-  Sinkhole
-  Slide or Slip
-  Sodic Spot
-  Spoil Area
-  Stony Spot
-  Very Stony Spot
-  Wet Spot
-  Other
-  Special Line Features
- Water Features**
-  Streams and Canals
- Transportation**
-  Rails
-  Interstate Highways
-  US Routes
-  Major Roads
-  Local Roads
- Background**
-  Aerial Photography

MAP INFORMATION

The soil surveys that comprise your AOI were mapped at 1:20,000.

Warning: Soil Map may not be valid at this scale.
 Enlargement of maps beyond the scale of mapping can cause misunderstanding of the detail of mapping and accuracy of soil line placement. The maps do not show the small areas of contrasting soils that could have been shown at a more detailed scale.

Please rely on the bar scale on each map sheet for map measurements.
 Source of Map: Natural Resources Conservation Service
 Web Soil Survey URL: <http://websoilsurvey.nrcs.usda.gov>
 Coordinate System: Web Mercator (EPSG:3857)

Maps from the Web Soil Survey are based on the Web Mercator projection, which preserves direction and shape but distorts distance and area. A projection that preserves area, such as the Albers equal-area conic projection, should be used if more accurate calculations of distance or area are required.

This product is generated from the USDA-NRCS certified data as of the version date(s) listed below.

Soil Survey Area: Castle Rock Area, Colorado
 Survey Area Data: Version 8, Sep 23, 2014

Soil map units are labeled (as space allows) for map scales 1:50,000 or larger.

Date(s) aerial images were photographed: Jun 10, 2014—Aug 21, 2014

The orthophoto or other base map on which the soil lines were compiled and digitized probably differs from the background imagery displayed on these maps. As a result, some minor shifting of map unit boundaries may be evident.



COMPARK VILLAGE SOUTH FILING NO. 1
 TOWN OF PARKER, CO
 SOIL MAP EXHIBIT

RJM
 RAK
 1/14/16
 1:6, 890
 SHEET
2
 CLCPKC3

11:25 D:\a\Name: P:\C\clcpkc3\ComSouth05-Residential_Preliminary_Plot\Documents\Engineering\StormWater_Reports\Preliminary_Report\Soil_Map_Exhibit.dwg Updated By: rjatz

Soil Map—Castle Rock Area, Colorado

Map Unit Legend

Castle Rock Area, Colorado (CO622)			
Map Unit Symbol	Map Unit Name	Acres in AOI	Percent of AOI
FoB	Fondis clay loam, 1 to 3 percent slopes	12.3	12.1%
FoD	Fondis clay loam, 3 to 9 percent slopes	13.2	12.9%
NeE	Newlin gravelly sandy loam, 8 to 30 percent slopes	76.6	75.0%
Totals for Area of Interest		102.1	100.0%



Natural Resources
Conservation Service

Web Soil Survey
National Cooperative Soil Survey

1/14/2016
Page 3 of 3

C1CPK03

3

SHEET

1:6,890

1/14/16

RAK

RAM

COMPARK VILLAGE SOUTH FILING NO. 1

TOWN OF PARKER, CO

SOIL MAP EXHIBIT

Manhard
CONSULTING LTD

2025 Arapahoe County, Box 116 (Denver, CO 80116) public@manhard.com 303.758.0400 manhard.com
Civil Engineers • Surveyors • Water Resources Engineers • Water & Wastewater Engineers
Construction Management • Environmental Sciences • Landmarks Architecture • Planning

APPENDIX B

Hydrologic Analysis

- UDFCD Table 6-3
- UDFCD Table 6-4
- UDFCD Table 6-5
- UDFCD Figures 6-1, 6-2 & 6-3
- Impervious Percentage Calculations
- Time of Concentration Calculations
- 2-Year Storm Runoff Calculations
- 5-Year Storm Runoff Calculations
- 100-Year Storm Runoff Calculations

Table 6-3. Recommended percentage imperviousness values

Land Use or Surface Characteristics	Percentage Imperviousness (%)
Business:	
Downtown Areas	95
Suburban Areas	75
Residential:	
Single-family	
2.5 acres or larger	12
0.75 – 2.5 acres	20
0.25 – 0.75 acres	30
0.25 acres or less	45
Apartments	75
Industrial:	
Light areas	80
Heavy areas	90
Parks, cemeteries	10
Playgrounds	25
Schools	55
Railroad yard areas	50
Undeveloped Areas:	
Historic flow analysis	2
Greenbelts, agricultural	2
Off-site flow analysis (when land use not defined)	45
Streets:	
Paved	100
Gravel (packed)	40
Drive and walks	90
Roofs	90
Lawns, sandy soil	2
Lawns, clayey soil	2

Table 6-4. Runoff coefficient equations based on NRCS soil group and storm return period

NRCS Soil Group	Storm Return Period					
	2-Year	5-Year	10-Year	25-Year	50-Year	100-Year
A	$C_A = 0.89i$	$C_A = 0.93i$	$C_A = 0.94i$	$C_A = 0.944i$	$C_A = 0.95i$	$C_A = 0.81i + 0.154$
B	$C_B = 0.89i$	$C_B = 0.93i$	$C_B = 0.81i + 0.125$	$C_B = 0.70i + 0.23$	$C_B = 0.59i + 0.364$	$C_B = 0.49i + 0.454$
C/D	$C_{C/D} = 0.89i$	$C_{C/D} = 0.87i + 0.052$	$C_{C/D} = 0.74i + 0.2$	$C_{C/D} = 0.64i + 0.31$	$C_{C/D} = 0.54i + 0.418$	$C_{C/D} = 0.45i + 0.508$

Where:

i = % imperviousness (expressed as a decimal)

C_A = Runoff coefficient for Natural Resources Conservation Service (NRCS) HSG A soils

C_B = Runoff coefficient for NRCS HSG B soils

$C_{C/D}$ = Runoff coefficient for NRCS HSG C and D soils.

The values for various catchment imperviousness and storm return periods are presented graphically in Figures 6-1 through 6-3, and are tabulated in Table 6-5. These coefficients were developed for the Denver region to work in conjunction with the time of concentration recommendations in Section 2.4. Use of these coefficients and this procedure outside of the semi-arid climate found in the Denver region may not be valid. The UD-Rational Excel workbook performs all the needed calculations to find the runoff coefficient given the soil type and imperviousness and the reader may want to take advantage of this macro-enabled Excel workbook that is available for download from the UDFCD's website www.udfcd.org.

See Examples 7.1 and 7.2 that illustrate the Rational Method.

Table 6-5. Runoff coefficients, *c*

Total or Effective % Imperviousness	NRCS Hydrologic Soil Group A					
	2-yr	5-yr	10-yr	25-yr	50-yr	100-yr
2%	0.02	0.02	0.02	0.02	0.02	0.17
5%	0.04	0.05	0.05	0.05	0.05	0.19
10%	0.09	0.09	0.09	0.09	0.1	0.23
15%	0.13	0.14	0.14	0.14	0.14	0.28
20%	0.18	0.19	0.19	0.19	0.19	0.32
25%	0.22	0.23	0.24	0.24	0.24	0.36
30%	0.27	0.28	0.28	0.28	0.29	0.4
35%	0.31	0.33	0.33	0.33	0.33	0.44
40%	0.36	0.37	0.38	0.38	0.38	0.48
45%	0.4	0.42	0.42	0.42	0.43	0.52
50%	0.45	0.47	0.47	0.47	0.48	0.56
55%	0.49	0.51	0.52	0.52	0.52	0.6
60%	0.53	0.56	0.56	0.57	0.57	0.64
65%	0.58	0.6	0.61	0.61	0.62	0.68
70%	0.62	0.65	0.66	0.66	0.67	0.72
75%	0.67	0.7	0.71	0.71	0.71	0.76
80%	0.71	0.74	0.75	0.76	0.76	0.8
85%	0.76	0.79	0.8	0.8	0.81	0.84
90%	0.8	0.84	0.85	0.85	0.86	0.88
95%	0.85	0.88	0.89	0.9	0.9	0.92
100%	0.89	0.93	0.94	0.94	0.95	0.96
Total or Effective % Imperviousness	NRCS Hydrologic Soil Group B					
2%	0.02	0.02	0.14	0.24	0.38	0.46
5%	0.04	0.05	0.17	0.27	0.39	0.48
10%	0.09	0.09	0.21	0.3	0.42	0.5
15%	0.13	0.14	0.25	0.34	0.45	0.53
20%	0.18	0.19	0.29	0.37	0.48	0.55
25%	0.22	0.23	0.33	0.41	0.51	0.58
30%	0.27	0.28	0.37	0.44	0.54	0.6
35%	0.31	0.33	0.41	0.48	0.57	0.63
40%	0.36	0.37	0.45	0.51	0.6	0.65
45%	0.4	0.42	0.49	0.55	0.63	0.67
50%	0.45	0.47	0.53	0.58	0.66	0.7
55%	0.49	0.51	0.57	0.62	0.69	0.72
60%	0.53	0.56	0.61	0.65	0.72	0.75
65%	0.58	0.6	0.65	0.69	0.75	0.77
70%	0.62	0.65	0.69	0.72	0.78	0.8
75%	0.67	0.7	0.73	0.76	0.81	0.82
80%	0.71	0.74	0.77	0.79	0.84	0.85
85%	0.76	0.79	0.81	0.83	0.87	0.87
90%	0.8	0.84	0.85	0.86	0.89	0.9
95%	0.85	0.88	0.89	0.9	0.92	0.92
100%	0.89	0.93	0.94	0.94	0.95	0.94

Table 6-5. Runoff coefficients, *c* (continued)

Total or Effective % Imperviousness	NRCS Hydrologic Soil Groups C and D					
	2-yr	5-yr	10-yr	25-yr	50-yr	100-yr
2%	0.02	0.07	0.22	0.32	0.43	0.52
5%	0.04	0.1	0.24	0.34	0.45	0.53
10%	0.09	0.14	0.27	0.37	0.47	0.55
15%	0.13	0.18	0.31	0.41	0.5	0.58
20%	0.18	0.23	0.35	0.44	0.53	0.6
25%	0.22	0.27	0.39	0.47	0.55	0.62
30%	0.27	0.31	0.42	0.5	0.58	0.64
35%	0.31	0.36	0.46	0.53	0.61	0.67
40%	0.36	0.4	0.5	0.57	0.63	0.69
45%	0.4	0.44	0.53	0.6	0.66	0.71
50%	0.45	0.49	0.57	0.63	0.69	0.73
55%	0.49	0.53	0.61	0.66	0.72	0.76
60%	0.53	0.57	0.64	0.69	0.74	0.78
65%	0.58	0.62	0.68	0.73	0.77	0.8
70%	0.62	0.66	0.72	0.76	0.8	0.82
75%	0.67	0.7	0.76	0.79	0.82	0.85
80%	0.71	0.75	0.79	0.82	0.85	0.87
85%	0.76	0.79	0.83	0.85	0.88	0.89
90%	0.8	0.83	0.87	0.89	0.9	0.91
95%	0.85	0.88	0.9	0.92	0.93	0.94
100%	0.89	0.92	0.94	0.95	0.96	0.96

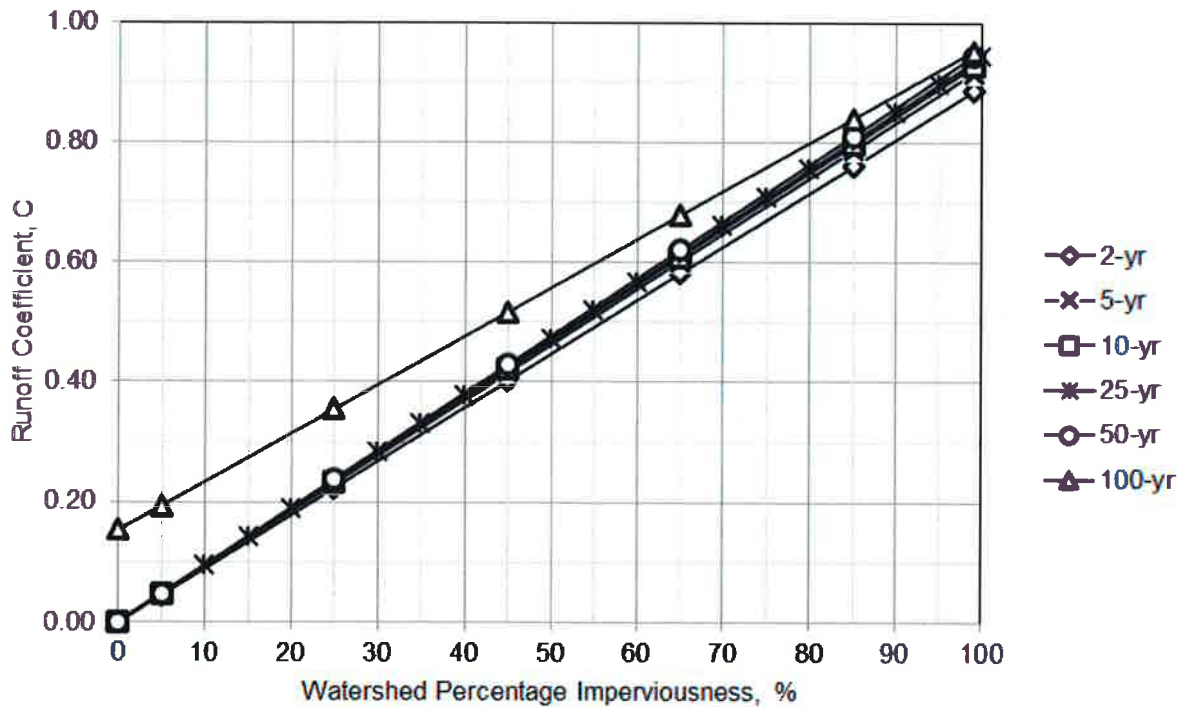

Figure 6-1. Runoff coefficient vs. watershed imperviousness NRCS HSG A

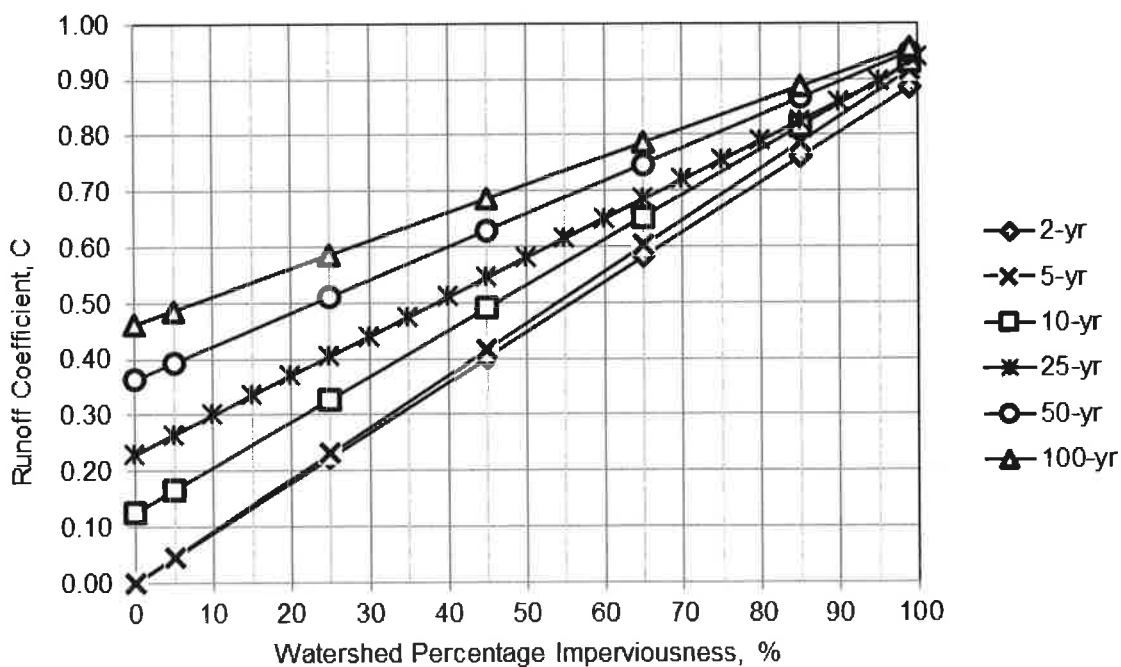

Figure 6-2. Runoff coefficient vs. watershed imperviousness NRCS HSG B

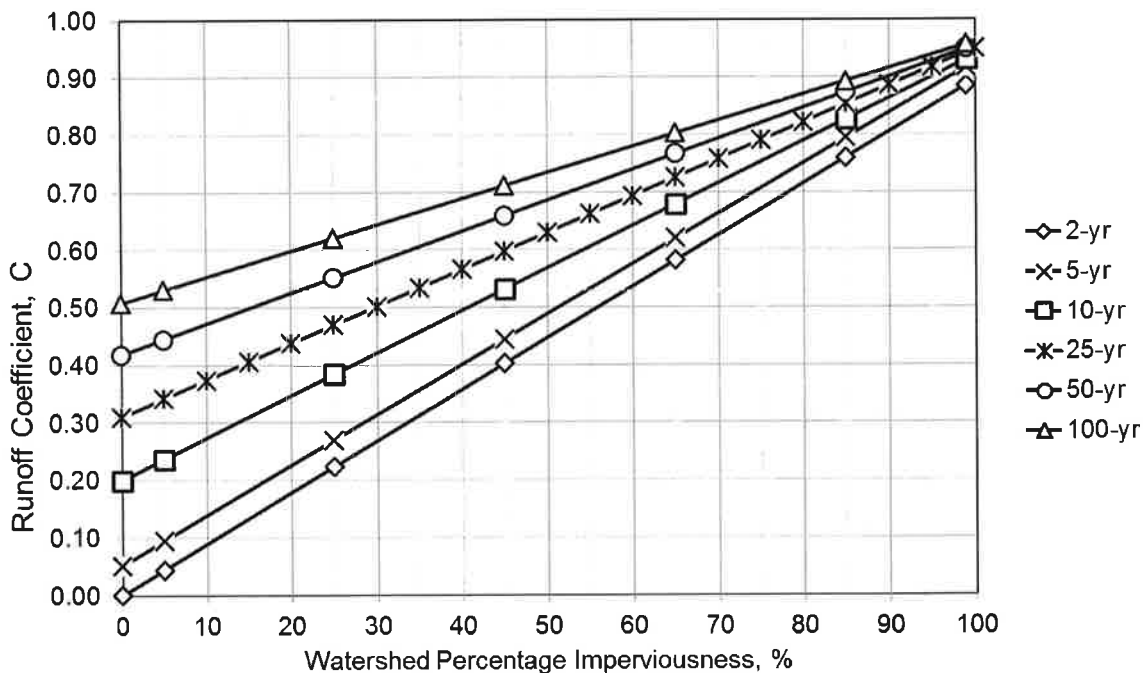

Figure 6-3. Runoff coefficient vs. watershed imperviousness NRCS HSG C and D

Compark South

TOWN OF PARKER, COLORADO PROPOSED IMPERVIOUSNESS CALCULATIONS 7-20-20

CVS-1

Land Use	Imperviousness (UDFCD Table 6-3)	Total Area (Acres)	Impervious Area (Acres)
Pavement/Hardscape	100%	1.18	1.18
Landscape	2%	2.67	0.05

Total Area: 3.85

Percentage Imperviousness: 32.0%
C₂ (Table 6-4, Type C Soil): 0.28
C₅ (Table 6-4, Type C Soil): 0.33
C₁₀₀ (Table 6-4, Type C Soil): 0.65

CVS-2

Land Use	Imperviousness (UDFCD Table 6-3)	Total Area (Acres)	Impervious Area (Acres)
Pavement/Hardscape	100%	1.09	1.09
Landscape	2%	0.33	0.01

Total Area: 1.42

Percentage Imperviousness: 77.0%
C₂ (Table 6-4, Type C Soil): 0.69
C₅ (Table 6-4, Type C Soil): 0.72
C₁₀₀ (Table 6-4, Type C Soil): 0.85

CVS-3

Land Use	Imperviousness (UDFCD Table 6-3)	Total Area (Acres)	Impervious Area (Acres)
Pavement/Hardscape	100%	0.57	0.57
Landscape	2%	0.37	0.01

Total Area: 0.94

Percentage Imperviousness: 62.0%
C₂ (Table 6-4, Type B Soil): 0.55
C₅ (Table 6-4, Type B Soil): 0.58
C₁₀₀ (Table 6-4, Type B Soil): 0.76

CVS-4

Land Use	Imperviousness (UDFCD Table 6-3)	Total Area (Acres)	Impervious Area (Acres)
Pavement/Hardscape	100%	0.56	0.56
Landscape	2%	0.61	0.01

Total Area: 1.17

Percentage Imperviousness: 49.0%
C₂ (Table 6-4, Type B Soil): 0.44
C₅ (Table 6-4, Type B Soil): 0.46
C₁₀₀ (Table 6-4, Type B Soil): 0.69

*Note: Impervious percentages were determined using Figures 3-3, 3-4, 3-5 from Volume 3 of the Urban Storm Drainage Criteria Manual.

CVS-4A

Percentage Imperviousness*:	55.0%
C₂ (Table 6-4, Type B Soil):	0.49
C₅ (Table 6-4, Type B Soil):	0.51
C₁₀₀ (Table 6-4, Type B Soil):	0.72

CVS-5

Percentage Imperviousness*:	45.0%
C₂ (Table 6-4, Type B Soil):	0.40
C₅ (Table 6-4, Type B Soil):	0.42
C₁₀₀ (Table 6-4, Type B Soil):	0.67

CVS-6

Land Use	Imperviousness (UDFCD Table 6-3)	Total Area (Acres)	Impervious Area (Acres)
Pavement/Hardscape	100%	0.28	0.28
Landscape	2%	0.37	0.01
Total Area:		0.65	

Percentage Imperviousness:	45.0%
C₂ (Table 6-4, Type B Soil):	0.40
C₅ (Table 6-4, Type B Soil):	0.42
C₁₀₀ (Table 6-4, Type B Soil):	0.67

CVS-6A

Land Use	Imperviousness (UDFCD Table 6-3)	Total Area (Acres)	Impervious Area (Acres)
Pavement/Hardscape	100%	0.00	0.00
Landscape	2%	0.78	0.02
Total Area:		0.78	

Percentage Imperviousness:	2.0%
C₂ (Table 6-4, Type B Soil):	0.02
C₅ (Table 6-4, Type B Soil):	0.02
C₁₀₀ (Table 6-4, Type B Soil):	0.46

CVS-7

Land Use	Imperviousness (UDFCD Table 6-3)	Total Area (Acres)	Impervious Area (Acres)
Pavement/Hardscape	100%	0.86	0.86
Landscape	2%	0.25	0.01
Total Area:		1.11	

Percentage Imperviousness:	78.0%
C₂ (Table 6-4, Type B Soil):	0.69
C₅ (Table 6-4, Type B Soil):	0.73
C₁₀₀ (Table 6-4, Type B Soil):	0.84

*Note: Impervious percentages were determined using Figures 3-3, 3-4, 3-5 from Volume 3 of the Urban Storm Drainage Criteria Manual.

CVS-8

Land Use	Imperviousness (UDFCD Table 6-3)	Total Area (Acres)	Impervious Area (Acres)
Pavement/Hardscape	100%	0.86	0.86
Landscape	2%	0.73	0.01

Total Area: 1.59

Percentage Imperviousness: 55.0%
C₂ (Table 6-4, Type B Soil): 0.49
C₅ (Table 6-4, Type B Soil): 0.51
C₁₀₀ (Table 6-4, Type B Soil): 0.72

CVS-9

Percentage Imperviousness*: 55.0%
C₂ (Table 6-4, Type B Soil): 0.49
C₅ (Table 6-4, Type B Soil): 0.51
C₁₀₀ (Table 6-4, Type B Soil): 0.72

CVS-9A

Percentage Imperviousness*: 55.0%
C₂ (Table 6-4, Type B Soil): 0.49
C₅ (Table 6-4, Type B Soil): 0.51
C₁₀₀ (Table 6-4, Type B Soil): 0.72

CVS-10

Percentage Imperviousness*: 51.0%
C₂ (Table 6-4, Type B Soil): 0.45
C₅ (Table 6-4, Type B Soil): 0.47
C₁₀₀ (Table 6-4, Type B Soil): 0.70

CVS-10A

Land Use	Imperviousness (UDFCD Table 6-3)	Total Area (Acres)	Impervious Area (Acres)
Pavement/Hardscape	100%	0.25	0.25
Landscape	2%	0.15	0.00

Total Area: 0.40

Percentage Imperviousness: 63.0%
C₂ (Table 6-4, Type B Soil): 0.56
C₅ (Table 6-4, Type B Soil): 0.59
C₁₀₀ (Table 6-4, Type B Soil): 0.76

CVS-11

Land Use	Imperviousness (UDFCD Table 6-3)	Total Area (Acres)	Impervious Area (Acres)
Pavement/Hardscape	100%	2.08	2.08
Landscape	2%	1.39	0.03

Total Area: 3.47

Percentage Imperviousness: 78.0%
C₂ (Table 6-4, Type B Soil): 0.69
C₅ (Table 6-4, Type B Soil): 0.73
C₁₀₀ (Table 6-4, Type B Soil): 0.84

*Note: Impervious percentages were determined using Figures 3-3, 3-4, 3-5 from Volume 3 of the Urban Storm Drainage Criteria Manual.

CVS-12

Percentage Imperviousness*:	55.0%
C₂ (Table 6-4, Type B Soil):	0.49
C₅ (Table 6-4, Type B Soil):	0.51
C₁₀₀ (Table 6-4, Type B Soil):	0.72

CVS-12A

Percentage Imperviousness*:	55.0%
C₂ (Table 6-4, Type B Soil):	0.49
C₅ (Table 6-4, Type B Soil):	0.51
C₁₀₀ (Table 6-4, Type B Soil):	0.72

CVS-12B

Percentage Imperviousness*:	55.0%
C₂ (Table 6-4, Type B Soil):	0.49
C₅ (Table 6-4, Type B Soil):	0.51
C₁₀₀ (Table 6-4, Type B Soil):	0.72

CVS-13

Percentage Imperviousness*:	55.0%
C₂ (Table 6-4, Type B Soil):	0.49
C₅ (Table 6-4, Type B Soil):	0.51
C₁₀₀ (Table 6-4, Type B Soil):	0.72

CVS-13A

Land Use	Imperviousness (UDFCD Table 6-3)	Total Area (Acres)	Impervious Area (Acres)
Pavement/Hardscape	100%	0.76	0.76
Landscape	2%	0.48	0.01

Total Area: 1.24

Percentage Imperviousness:	62.0%
C₂ (Table 6-4, Type B Soil):	0.55
C₅ (Table 6-4, Type B Soil):	0.58
C₁₀₀ (Table 6-4, Type B Soil):	0.76

CVS-13B

Land Use	Imperviousness (UDFCD Table 6-3)	Total Area (Acres)	Impervious Area (Acres)
Pavement/Hardscape	100%	0.79	0.79
Landscape	2%	0.48	0.01

Total Area: 1.27

Percentage Imperviousness:	63.0%
C₂ (Table 6-4, Type B Soil):	0.56
C₅ (Table 6-4, Type B Soil):	0.59
C₁₀₀ (Table 6-4, Type B Soil):	0.76

*Note: Impervious percentages were determined using Figures 3-3, 3-4, 3-5 from Volume 3 of the Urban Storm Drainage Criteria Manual.

CVS-13C

Percentage Imperviousness*:	55.0%
C₂ (Table 6-4, Type B Soil):	0.49
C₅ (Table 6-4, Type B Soil):	0.51
C₁₀₀ (Table 6-4, Type B Soil):	0.72

CVS-14

Percentage Imperviousness:	55.0%
C₂ (Table 6-4, Type B Soil):	0.49
C₅ (Table 6-4, Type B Soil):	0.51
C₁₀₀ (Table 6-4, Type B Soil):	0.72

CVS-14A

Land Use	Imperviousness (UDFCD Table 6-3)	Total Area (Acres)	Impervious Area (Acres)
Pavement/Hardscape	100%	0.00	0.00
Landscape	2%	4.12	0.08

Total Area: 4.12

Percentage Imperviousness:	2.0%
C₂ (Table 6-4, Type B Soil):	0.02
C₅ (Table 6-4, Type B Soil):	0.02
C₁₀₀ (Table 6-4, Type B Soil):	0.46

CVS-14B

Land Use	Imperviousness (UDFCD Table 6-3)	Total Area (Acres)	Impervious Area (Acres)
Pavement/Hardscape	100%	0.18	0.18
Landscape	2%	2.55	0.05

Total Area: 2.73

Percentage Imperviousness:	8.0%
C₂ (Table 6-4, Type B Soil):	0.07
C₅ (Table 6-4, Type B Soil):	0.07
C₁₀₀ (Table 6-4, Type B Soil):	0.49

CVS-14C

Percentage Imperviousness:	55.0%
C₂ (Table 6-4, Type B Soil):	0.49
C₅ (Table 6-4, Type B Soil):	0.51
C₁₀₀ (Table 6-4, Type B Soil):	0.72

CVS-15

Percentage Imperviousness*:	55.0%
C₂ (Table 6-4, Type B Soil):	0.49
C₅ (Table 6-4, Type B Soil):	0.51
C₁₀₀ (Table 6-4, Type B Soil):	0.72

*Note: Impervious percentages were determined using Figures 3-3, 3-4, 3-5 from Volume 3 of the Urban Storm Drainage Criteria Manual.

CVS-15A

Land Use	Imperviousness (UDFCD Table 6-3)	Total Area (Acres)	Impervious Area (Acres)
Pavement/Hardscape	100%	0.55	0.55
Landscape	2%	0.40	0.01

Total Area: 0.95

Percentage Imperviousness: 59.0%
C₂ (Table 6-4, Type B Soil): 0.53
C₅ (Table 6-4, Type B Soil): 0.55
C₁₀₀ (Table 6-4, Type B Soil): 0.74

CVS-16

Percentage Imperviousness*: 55.0%
C₂ (Table 6-4, Type B Soil): 0.49
C₅ (Table 6-4, Type B Soil): 0.51
C₁₀₀ (Table 6-4, Type B Soil): 0.72

CVS-17

Percentage Imperviousness*: 55.0%
C₂ (Table 6-4, Type B Soil): 0.49
C₅ (Table 6-4, Type B Soil): 0.51
C₁₀₀ (Table 6-4, Type B Soil): 0.72

CVS-18

Percentage Imperviousness*: 50.0%
C₂ (Table 6-4, Type B Soil): 0.45
C₅ (Table 6-4, Type B Soil): 0.47
C₁₀₀ (Table 6-4, Type B Soil): 0.70

CVS-19

Percentage Imperviousness*: 73.0%
C₂ (Table 6-4, Type B Soil): 0.65
C₅ (Table 6-4, Type B Soil): 0.68
C₁₀₀ (Table 6-4, Type B Soil): 0.81

CVS-20

Percentage Imperviousness*: 55.0%
C₂ (Table 6-4, Type B Soil): 0.49
C₅ (Table 6-4, Type B Soil): 0.51
C₁₀₀ (Table 6-4, Type B Soil): 0.72

CVS-21

Percentage Imperviousness*: 55.0%
C₂ (Table 6-4, Type B Soil): 0.49
C₅ (Table 6-4, Type B Soil): 0.51
C₁₀₀ (Table 6-4, Type B Soil): 0.72

*Note: Impervious percentages were determined using Figures 3-3, 3-4, 3-5 from Volume 3 of the Urban Storm Drainage Criteria Manual.

CVS-22

Percentage Imperviousness*: **55.0%**
C₂ (Table 6-4, Type B Soil): **0.49**
C₅ (Table 6-4, Type B Soil): **0.51**
C₁₀₀ (Table 6-4, Type B Soil): **0.72**

CVS-23

28,409 sf Pavement & Bldg & 9,488 sf Lawn

Percentage Imperviousness*: **75.0%**
C₂ (Table 6-4, Type B Soil): **0.67**
C₅ (Table 6-4, Type B Soil): **0.70**
C₁₀₀ (Table 6-4, Type B Soil): **0.82**

BEL-1

Land Use	Imperviousness (UDFCD Table 6-3)	Total Area (Acres)	Impervious Area (Acres)
Pavement/Hardscape	100%	1.23	1.23
Landscape	2%	2.50	0.05

Total Area: 3.73

Percentage Imperviousness: **34.0%**
C₂ (Table 6-4, Type B Soil): **0.30**
C₅ (Table 6-4, Type B Soil): **0.32**
C₁₀₀ (Table 6-4, Type B Soil): **0.62**

BEL-2

Land Use	Imperviousness (UDFCD Table 6-3)	Total Area (Acres)	Impervious Area (Acres)
Pavement/Hardscape	100%	0.68	0.68
Landscape	2%	0.70	0.01

Total Area: 1.38

Percentage Imperviousness: **77.0%**
C₂ (Table 6-4, Type B Soil): **0.69**
C₅ (Table 6-4, Type B Soil): **0.72**
C₁₀₀ (Table 6-4, Type B Soil): **0.83**

BEL-3

Land Use	Imperviousness (UDFCD Table 6-3)	Total Area (Acres)	Impervious Area (Acres)
Pavement/Hardscape	100%	1.34	1.34
Landscape	2%	5.42	0.11

Total Area: 6.76

Percentage Imperviousness: **21.0%**
C₂ (Table 6-4, Type B Soil): **0.19**
C₅ (Table 6-4, Type B Soil): **0.20**
C₁₀₀ (Table 6-4, Type B Soil): **0.56**

BEL-4

Land Use	Imperviousness (UDFCD Table 6-3)	Total Area (Acres)	Impervious Area (Acres)
Pavement/Hardscape	100%	1.36	1.36
Landscape	2%	0.39	0.01

Total Area: 1.75

Percentage Imperviousness: **78.0%**
C₂ (Table 6-4, Type B Soil): **0.69**
C₅ (Table 6-4, Type B Soil): **0.73**
C₁₀₀ (Table 6-4, Type B Soil): **0.84**

*Note: Impervious percentages were determined using Figures 3-3, 3-4, 3-5 from Volume 3 of the Urban Storm Drainage Criteria Manual.

BEL-5

Land Use	Imperviousness (UDFCD Table 6-3)	Total Area (Acres)	Impervious Area (Acres)
Pavement/Hardscape	100%	3.43	3.43
Landscape	2%	1.12	0.02

Total Area: 4.55

Percentage Imperviousness: 76.0%
C₂ (Table 6-4, Type B Soil): 0.68
C₅ (Table 6-4, Type B Soil): 0.71
C₁₀₀ (Table 6-4, Type B Soil): 0.83

BEL-6

Land Use	Imperviousness (UDFCD Table 6-3)	Total Area (Acres)	Impervious Area (Acres)
Pavement/Hardscape	100%	2.77	2.77
Landscape	2%	1.18	0.02

Total Area: 3.95

Percentage Imperviousness: 71.0%
C₂ (Table 6-4, Type B Soil): 0.63
C₅ (Table 6-4, Type B Soil): 0.66
C₁₀₀ (Table 6-4, Type B Soil): 0.80

*Note: Impervious percentages were determined using Figures 3-3, 3-4, 3-5 from Volume 3 of the Urban Storm Drainage Criteria Manual.

**PROPOSED DRAINAGE BASINS
STANDARD FORM SF-2
TIME OF CONCENTRATION**

PROJECT: **Compark Village South, Filing 1**
 CALCULATED BY: **RAK** DATE: **November 16, 2016**
 REVISED BY: DATE:

NOTES:
 $T_i = [0.395 \times (1.1 - C_i) \times L^{0.75}] / (S^{0.33})$
 $T_r = L / (60 \times V)$ (Velocity from UDFCD Fig. RO-1)
 T_c Check = $10 + L/180$ (Urbanized Basins Only)

JOB NO: **CLCPKGC3**

SUB-BASIN DATA			INITIAL/OVERLAND TIME (T _i)			TRAVEL TIME (T _t) - (GRASS SWALE)				TRAVEL TIME (T _t) - (PAVEMENT/CURB & GUTTER)				T _c CHECK (urbanized basins)		FINAL T _c (min)	REMARKS
AREA DESIGNATION	ROUGHNESS COEFFICIENT, C=100	AREA, A (acres)	FLOW LENGTH, (ft)	SLOPE (%)	INITIAL TIME, T _i (min)	FLOW LENGTH, (ft)	SLOPE (%)	VELOCITY (ft/s)	TRAVEL TIME, T _t (min)	FLOW LENGTH, (ft)	SLOPE (%)	VELOCITY (ft/s)	TRAVEL TIME, T _t (min)	TOTAL LENGTH (ft)	MAXIMUM T _c = (L/180 + 10)		
CVS-1 (Inlet 1-3)	0.65	3.85	0	0.0%	0.0	0	0.0%	0.0	0.0	1172	2.0%	2.8	6.9	1172	16.5	6.9	
CVS-2 (Inlet 2-3)	0.85	1.42	0	0.0%	0.0	0	0.0%	0.0	0.0	1125	2.0%	2.8	6.6	1125	16.3	6.6	
CVS-3 (Inlet 1-4)	0.76	0.94	0	0.0%	0.0	0	0.0%	0.0	0.0	1055	2.0%	2.8	6.2	1055	15.9	6.2	
CVS-4 (Inlet 2-4)	0.69	1.17	0	0.0%	0.0	0	0.0%	0.0	0.0	600	1.5%	2.4	4.1	600	13.3	4.1	
CVS-4A (Inlet 3-4)	0.72	2.20	100	2.0%	5.4	180	2.0%	1.0	3.0	416	1.5%	2.4	2.8	696	13.9	11.3	
CVS-5 (Inlet 5-4)	0.67	2.19	100	4.0%	4.9	130	5.0%	1.6	1.3	380	1.3%	2.3	2.8	610	13.4	9.0	
CVS-6 (Inlet 6-4)	0.67	0.58	-	-	-	-	-	-	-	-	-	-	-	-	-	5.0	Minimum
CVS-6A (FES 2-4)	0.46	0.78	-	-	-	-	-	-	-	-	-	-	-	-	-	5.0	Minimum
CVS-7 (Inlet 1-6)	0.84	1.11	0	0.0%	0.0	0	0.0%	0.0	0.0	904	0.6%	1.5	10.2	904	15.0	10.2	
CVS-8 (Inlet 2-6)	0.72	1.59	0	0.0%	0.0	0	0.0%	0.0	0.0	897	0.6%	1.5	10.1	897	15.0	10.1	
CVS-9 (Inlet 4-5A)	0.72	2.41	100	2.0%	5.4	180	2.0%	1.0	3.0	440	1.1%	2.1	3.5	720	14.0	11.9	
CVS-9A (Inlet 3-4)	0.72	0.37	-	-	-	-	-	-	-	-	-	-	-	-	-	5.0	Minimum
CVS-10 (Inlet 5-5A)	0.70	2.78	100	2.0%	5.7	180	2.0%	1.0	3.0	594	1.0%	2.0	5.0	874	14.9	13.7	
CVS-10A (Inlet 5-4A)	0.76	0.40	100	2.0%	4.8	55	2.0%	1.0	0.9	5	1.0%	2.0	0.0	160	10.9	5.8	
CVS-11 (Inlet 1-5)	0.84	2.03	0	0.0%	0.0	0	0.0%	0.0	0.0	1046	0.5%	1.4	12.3	1046	15.8	12.3	
CVS-12 (Inlet 2-5)	0.72	4.58	100	1.5%	5.9	48	1.5%	0.9	0.9	599	1.0%	2.0	5.0	747	14.2	11.9	
CVS-12A (Inlet 3-5)	0.72	0.81	100	2.0%	5.4	120	2.0%	1.0	2.0	30	1.0%	2.0	0.3	250	11.4	7.7	
CVS-12B (Inlet 3-5)	0.72	1.31	100	2.0%	5.4	190	2.0%	1.0	3.2	350	1.8%	2.7	2.2	640	13.6	10.8	
CVS-13 (Inlet 4-5)	0.72	1.16	100	4.7%	4.1	81	2.0%	1.0	1.4	230	1.0%	2.0	1.9	411	12.3	7.4	
CVS 13A (Inlet 6-5A)	0.76	1.20	55	2.0%	3.6	0	0.0%	0.0	0.0	817	1.8%	2.7	5.1	872	14.8	8.7	
CVS 13B (Inlet 4-5B)	0.76	1.53	55	2.0%	3.6	0	0.0%	0.0	0.0	877	1.8%	2.7	5.4	932	15.2	9.0	
CVS 13C (Inlet 4-5C)	0.72	1.26	100	2.0%	5.4	81	2.0%	1.0	1.4	250	1.0%	2.0	2.1	431	12.4	8.8	
CVS-14 (Inlet 6-5)	0.72	1.89	100	2.0%	5.4	40	2.0%	1.0	0.7	608	1.0%	2.0	5.1	748	14.2	11.1	
CVS-14A (Inlet 7-5)	0.46	4.01	100	5.0%	6.8	1258	2.0%	1.0	21.2	0	0.0%	0.0	0.0	1358	17.5	17.5	
CVS-14B (Inlet 6-5)	0.49	2.73	100	5.0%	6.4	512	3.0%	1.2	7.0	5	1.0%	2.0	0.0	617	13.4	13.4	
CVS-14C (Inlet 5-5B)	0.72	1.93	100	2.0%	5.4	40	2.0%	1.0	0.7	634	1.0%	2.0	5.3	774	14.3	11.4	
CVS-15 (Inlet 5-5)	0.72	2.01	100	2.0%	5.4	170	2.0%	1.0	2.9	619	1.0%	2.0	5.2	889	14.9	13.4	
CVS-15A (Inlet 6-5B)	0.74	0.95	55	2.0%	3.8	0	0.0%	0.0	0.0	698	2.0%	2.8	4.1	753	14.2	7.9	
CVS-16 (Inlet 2-11A)	0.72	1.37	100	1.5%	5.9	49	1.5%	0.9	1.0	376	1.0%	2.0	3.1	525	12.9	10.0	
CVS-17 (Inlet 2-11)	0.72	1.44	100	5.3%	3.9	129	5.3%	1.6	1.3	376	1.0%	2.0	3.1	605	13.4	8.4	
CVS-17A	0.72	2.18	100	4.5%	4.2	544	1.0%	0.7	13.0					644	13.6	13.6	
CVS-18	0.70	2.69	100	15.5%	2.9	115	3.0%	1.2	1.6	655	1.0%	2.0	5.5	870	14.8	10.0	
CVS-19	0.81	1.61	100	3.5%	3.4	200	3.5%	1.3	2.5	0	0.0%	0.0	0.0	300	11.7	6.0	
CVS-20	0.72	1.62	100	2.0%	5.4	17	2.0%	1.0	0.3	570	1.0%	2.0	4.8	687	13.8	10.4	
CVS-21	0.72	3.86	100	0.0%	21.0	164	3.3%	1.3	2.1	833	1.1%	2.1	6.6	1097	16.1	16.1	
CVS-22 (Inlet 2-10A)	0.72	0.87	100	2.6%	4.9	0	0.0%	0.0	0.0	233	2.6%	3.2	1.2	333	11.9	6.2	
CVS-23 (Inlet 2-10)	0.82	0.87	100	2.7%	3.6					229	1.0%	2.0	1.9	329	11.8	5.5	
BEL-1 (Inlet 2-1)	0.62	3.73	100	1.5%	7.6	466	1.5%	0.9	9.1	462	0.8%	1.8	4.4	508	12.8	12.8	
BEL-2 (Inlet 1-1)	0.83	1.38	0	0.0%	0.0	0	0.0%	0.0	0.0	1123	1.5%	2.4	7.6	1123	16.2	7.6	
BEL-3 (Inlet 2-2)	0.56	6.76	100	1.5%	8.6	232	1.5%	0.9	4.5	462	0.8%	1.8	4.3	794	14.4	14.4	
BEL-4 (Inlet 1-2)	0.84	1.75	0	0.0%	0.0	0	0.0%	0.0	0.0	825	0.8%	1.7	7.9	825	14.6	7.9	
BEL-5	0.83	4.55	100	3.1%	3.4	0	0.0%	0.0	0.0	1602	3.1%	3.5	7.6	1702	19.5	11.0	
BEL-6	0.80	3.95	100	9.8%	2.5	0	0.0%	0.0	0.0	1009	3.0%	3.5	4.9	1109	16.2	7.4	

**PROPOSED DRAINAGE BASINS
STANDARD FORM SF-3
STORM DRAINAGE SYSTEM DESIGN
(RATIONAL METHOD PROCEDURE)**

PROJECT: COMPARK VILLAGE SOUTH, FILINGS 1 & 2 CLCPKC3

CALCULATED BY: RAK DATE: November 18, 2016 Manning's n-value = 0.013

REVISED BY: ASD DATE: July 20, 2020 2-YEAR

Basin ID	Design Point	DIRECT RUNOFF							Total Runoff, Q (cfs)	INLET					REMARKS
		Area (ac)	Tc (min.)	Runoff Coefficient, C	Intensity, I (in/hr)	C*A (Acres)	Direct Runoff, Q (cfs)	Intercepted (cfs)		Bypass (cfs)	Design Flow (cfs)	Slope (%)	Pipe Size (inches)		
CVS-1 (Inlet 1-3)	1	3.85	6.9	0.28	4.3	1.10	4.7	4.7	4.7	0.0	8.9	3.1%	24		
CVS-2 (Inlet 2-3)	2	1.42	6.6	0.69	4.3	0.97	4.2	4.2	4.2	0.0	4.2	10.0%	24		
CVS-3 (Inlet 1-4)	3	0.94	6.2	0.55	4.4	0.52	2.3	2.3	2.3	0.0	2.3	1.7%	18		
CVS-4 (Inlet 2-4)	4	1.17	4.1	0.44	5.0	0.51	2.5	2.5	2.5	0.0	2.5	0.9%	18		
CVS-4A (Inlet 3-4)	4A	2.20	11.3	0.49	3.6	1.08	3.9	3.9	3.9	0.0	3.9	1.0%	18		
CVS-5 (Inlet 5-4)	5	2.19	9.0	0.40	3.9	0.88	3.4	3.4	3.4	0.0	3.4	1.0%	18		
CVS-6 (Inlet 6-4)	6	0.58	5.0	0.40	4.7	0.23	1.1	1.1	1.1	0.0	9.6	1.7%	36		
CVS-6A (FES 2-4)	6A	0.78	5.0	0.02	4.7	0.01	0.1	0.1	0.1	0.0	8.5	3.1%	36		
CVS-7 (Inlet 1-6)	7	1.11	10.2	0.69	3.7	0.77	2.9	2.9	2.9	0.0	5.8	3.0%	24		
CVS-8 (Inlet 2-6)	8	1.59	10.1	0.49	3.7	0.78	2.9	2.9	2.9	0.0	2.9	1.4%	24		
CVS-9 (Inlet 4-5A)	9	2.41	11.9	0.49	3.5	1.18	4.1	4.1	4.1	0.0	4.1	1.2%	18		
CVS-9A (Inlet 4-4)	9A	0.37	5.0	0.49	4.7	0.18	0.9	0.9	0.9	0.0	0.9	1.0%	18		
CVS-10 (Inlet 5-5A)	10	2.78	13.7	0.45	3.3	1.26	4.2	4.2	4.2	0.0	4.2	1.2%	18		
CVS-10A (Inlet 5-4A)	10A	0.40	5.8	0.56	4.5	0.22	1.0	1.0	1.0	0.0	1.0	1.0%	18		
CVS-11 (Inlet 1-5)	11	2.03	12.3	0.69	3.4	1.41	4.9	4.9	4.9	0.0	12.8	0.8%	36		
CVS-12 (Inlet 2-5)	12	4.58	11.9	0.49	3.5	2.24	7.9	7.9	7.9	0.0	7.9	0.7%	36		
CVS-12A (Inlet 3-5)	12	0.81	7.7	0.49	4.1	0.40	1.6	1.6	1.6	0.0	40.0	1.9%	42		
CVS-12B (Inlet 3-5)	12A	1.31	10.8	0.49	3.6	0.64	2.3	2.3	2.3	0.0	40.0	1.9%	42		
CVS-13 (Inlet 4-5)	13	1.16	7.4	0.49	4.2	0.57	2.4	2.4	2.4	0.0	2.4	3.6%	18		
CVS 13A (Inlet 6-5A)	13A	1.20	8.7	0.55	4.0	0.66	2.6	2.6	2.6	0.0	2.6	1.0%	18		
CVS 13B (Inlet 4-5B)	13B	1.53	9.0	0.56	3.9	0.86	3.4	3.4	3.4	0.0	3.4	1.0%	18		
CVS 13C (Inlet 4-5C)	13C	1.26	8.8	0.49	3.9	0.62	2.4	2.4	2.4	0.0	2.4	1.0%	18		
CVS-14 (Inlet 6-5)	14	1.89	11.1	0.49	3.6	0.93	3.3	3.3	3.3	0.0	8.2	3.2%	30		
CVS-14A (Inlet 7-5)	14A	4.01	17.5	0.02	2.9	0.07	0.2	0.2	0.2	0.0	4.3	4.7%	24		
CVS-14B (Inlet 6-5)	14	2.73	13.4	0.07	3.3	0.19	0.6	0.6	0.6	0.0	8.6	3.4%	30		
CVS-14C (Inlet 5-5B)	14C	1.93	11.4	0.49	3.6	0.94	3.4	3.4	3.4	0.0	3.4	2.8%	18		
CVS-15 (Inlet 5-5)	15	2.05	13.4	0.49	3.3	1.00	3.3	3.3	3.3	0.0	3.3	5.0%	18		
CVS-15A (Inlet 6-5B)	15A	0.95	7.9	0.53	4.1	0.50	2.0	2.0	2.0	0.0	2.0	1.0%	18		
CVS-16 (Inlet 2-11A)	16	1.37	10.0	0.49	3.8	0.67	2.5	2.5	6.4	0.0	2.5	5.2%	18		
CVS-17 (Inlet 2-11)	17	1.44	8.4	0.49	4.0	0.70	1.9	1.9	6.8	0.0	1.9	5.2%	18		
CVS-17A	17A	2.18	13.6	0.49	3.3	1.07	3.5	3.5	-	-	-	-	-		
CVS-18	18	2.69	10.0	0.45	3.8	1.20	4.5	4.5	-	-	-	-	-		
CVS-19	19	1.61	6.0	0.65	4.5	1.05	4.7	4.7	-	-	-	-	-		
CVS-20	20	1.80	10.4	0.49	3.7	0.88	3.3	3.3	-	-	-	-	-		
CVS-21	21	3.88	16.1	0.49	3.1	1.90	5.8	5.8	-	-	-	-	-		
CVS-22 (Inlet 2-10A)	22	0.87	6.2	0.49	4.4	0.43	1.9	1.9	5.6	0.0	1.9	1.0%	18		
CVS-23 (Inlet 2-10)	23	0.87	5.5	0.67	4.6	0.58	2.7	2.7	7.1	0.0	2.7	1.0%	18		
BEL-1 (Inlet 2-1)	B1	3.73	12.8	0.30	3.4	1.13	3.8	3.8	3.8	0.0	5.9	3.3%	36		
BEL-2 (Inlet 1-1)	B2	1.38	7.6	0.69	4.2	0.95	3.9	3.9	3.9	0.0	8.4	0.9%	36		
BEL-3 (Inlet 2-2)	B3	6.76	14.4	0.19	3.2	1.26	4.1	4.1	4.1	0.0	6.6	3.2%	36		
BEL-4 (Inlet 1-2)	B4	1.75	7.9	0.69	4.1	1.21	5.0	5.0	5.0	0.0	11.6	2.9%	36		
BEL-5	B5	4.55	11.0	0.68	3.6	3.08	11.1	11.1	-	-	-	-	-		
BEL-6	B6	3.95	7.4	0.63	4.2	2.50	10.5	10.5	-	-	-	-	-		

**PROPOSED DRAINAGE BASINS
STANDARD FORM SF-3
STORM DRAINAGE SYSTEM DESIGN
(RATIONAL METHOD PROCEDURE)**

PROJECT: COMPARK VILLAGE SOUTH, FILINGS 1 & 2 CLCPKC3
 CALCULATED BY: RAK DATE: November 18, 2016 Manning's n-value = 0.013
 REVISED BY: ASD DATE: July 20, 2020 5-YEAR

Basin ID	Design Point	DIRECT RUNOFF							INLET		STORM SEWER			REMARKS
		Area (ac)	Tc (min.)	Runoff Coefficient, C	Intensity, I (in/hr)	C*A (Acres)	Direct Runoff, Q (cfs)	Total Runoff, Q (cfs)	Intercepted (cfs)	Bypass (cfs)	Design Flow (cfs)	Slope (%)	Pipe Size (inches)	
CVS-1 (Inlet 1-3)	1	3.85	6.9	0.33	4.3	1.27	5.5	5.5	5.5	0.0	10.0	3.1%	24	
CVS-2 (Inlet 2-3)	2	1.42	6.6	0.72	4.3	1.03	4.5	4.5	4.5	0.0	4.5	10.0%	24	
CVS-3 (Inlet 1-4)	3	0.94	6.2	0.58	4.4	0.54	2.4	2.4	2.4	0.0	2.4	1.7%	18	
CVS-4 (Inlet 2-4)	4	1.17	4.1	0.46	5.0	0.53	2.6	2.6	2.6	0.0	2.6	0.9%	18	
CVS-4A (Inlet 3-4)	4A	2.20	11.3	0.51	3.6	1.13	4.0	4.0	4.0	0.0	4.0	1.0%	18	
CVS-5 (Inlet 5-4)	5	2.19	9.0	0.42	3.9	0.92	3.6	3.6	3.6	0.0	3.6	1.0%	18	
CVS-6 (Inlet 6-4)	6	0.58	5.0	0.42	4.7	0.24	1.1	1.1	1.1	0.0	9.6	1.7%	36	
CVS-6A (FES 2-4)	6A	0.78	5.0	0.02	4.7	0.01	0.1	0.1	0.1	0.0	8.5	3.1%	36	
CVS-7 (Inlet 1-6)	7	1.11	10.2	0.73	3.7	0.81	3.0	3.0	3.0	0.0	6.0	3.0%	24	
CVS-8 (Inlet 2-6)	8	1.59	10.1	0.51	3.7	0.81	3.0	3.0	3.0	0.0	3.0	1.4%	24	
CVS-9 (Inlet 4-5A)	9	2.41	11.9	0.51	3.5	1.23	4.3	4.3	4.3	0.0	4.3	1.2%	18	
CVS-9A (Inlet 4-4)	9A	0.37	5.0	0.51	4.7	0.19	0.9	0.9	0.9	0.0	0.9	1.0%	18	
CVS-10 (Inlet 5-5A)	10	2.78	13.7	0.47	3.3	1.32	4.3	4.3	4.3	0.0	4.3	1.2%	18	
CVS-10A (Inlet 5-4A)	10A	0.40	5.8	0.59	4.5	0.23	1.1	1.1	1.1	0.0	1.1	1.0%	18	
CVS-11 (Inlet 1-5)	11	2.03	12.3	0.73	3.4	1.47	5.1	5.1	5.1	0.0	13.3	0.8%	36	
CVS-12 (Inlet 2-5)	12	4.58	11.9	0.51	3.5	2.34	8.2	8.2	8.2	0.0	8.2	0.7%	36	
CVS-12A (Inlet 3-5)	12	0.81	7.7	0.51	4.1	0.41	1.7	1.7	1.7	0.0	41.4	1.9%	42	
CVS-12B (Inlet 3-5)	12A	1.31	10.8	0.51	3.6	0.67	2.4	2.4	2.4	0.0	41.4	1.9%	42	
CVS-13 (Inlet 4-5)	13	1.16	7.4	0.51	4.2	0.59	2.5	2.5	2.5	0.0	2.5	3.6%	18	
CVS 13A (Inlet 6-5A)	13A	1.20	8.7	0.58	4.0	0.69	2.7	2.7	2.7	0.0	2.7	1.0%	18	
CVS 13B (Inlet 4-5B)	13B	1.53	9.0	0.59	3.9	0.90	3.5	3.5	3.5	0.0	3.5	1.0%	18	
CVS 13C (Inlet 4-5C)	13C	1.26	8.8	0.51	3.9	0.64	2.5	2.5	2.5	0.0	2.5	1.0%	18	
CVS-14 (Inlet 6-5)	14	1.89	11.1	0.51	3.6	0.97	3.5	3.5	3.5	0.0	8.5	3.2%	30	
CVS-14A (Inlet 7-5)	14A	4.01	17.5	0.02	2.9	0.07	0.2	0.2	0.2	0.0	4.3	4.7%	24	
CVS-14B (Inlet 6-5)	14	2.73	13.4	0.07	3.3	0.20	0.7	0.7	0.7	0.0	8.8	3.4%	30	
CVS-14C (Inlet 5-5B)	14C	1.93	11.4	0.51	3.6	0.99	3.5	3.5	3.5	0.0	3.5	2.8%	18	
CVS-15 (Inlet 5-5)	15	2.01	13.4	0.51	3.3	1.03	3.4	3.4	3.4	0.0	3.4	5.0%	18	
CVS-15A (Inlet 6-5B)	15A	0.95	7.9	0.55	4.1	0.52	2.1	2.1	2.1	0.0	2.1	1.0%	18	
CVS-16 (Inlet 2-11A)	16	1.37	10.0	0.51	3.8	0.70	2.6	2.6	6.4	0.0	2.6	5.2%	18	
CVS-17 (Inlet 2-11)	17	1.44	8.4	0.51	4.0	0.74	3.0	3.0	6.8	0.0	3.0	5.2%	18	
CVS-18	18	2.69	10.0	0.47	3.8	1.25	4.7	4.7	-	-	-	-	-	
CVS-19	19	1.61	6.0	0.68	4.5	1.09	4.9	4.9	-	-	-	-	-	
CVS-20	20	1.80	10.4	0.51	3.7	0.92	3.4	3.4	-	-	-	-	-	
CVS-21	21	3.88	16.1	0.51	3.1	1.98	6.1	6.1	-	-	-	-	-	
CVS-22 (2-10A)	22	0.87	6.2	0.51	4.4	0.45	2.0	2.0	5.6	0.0	2.0	1.0%	18	
CVS-23 (Inlet 2-10)	23	0.87	5.5	0.70	4.6	0.61	2.8	2.8	7.1	0.0	2.8	1.0%	18	
BEL-1 (Inlet 2-1)	B1	3.73	12.8	0.32	3.4	1.18	4.0	4.0	4.0	0.0	6.1	3.3%	36	
BEL-2 (Inlet 1-1)	B2	1.38	7.6	0.72	4.2	0.99	4.1	4.1	4.1	0.0	8.8	0.9%	36	
BEL-3 (Inlet 2-2)	B3	6.76	14.4	0.20	3.2	1.32	4.2	4.2	4.2	0.0	6.9	3.2%	36	
BEL-4 (Inlet 1-2)	B4	1.75	7.9	0.73	4.1	1.27	5.2	5.2	5.2	0.0	12.1	2.9%	36	
BEL-5	B5	4.55	11.0	0.71	3.6	3.22	11.6	11.6	-	-	-	-	-	
BEL-6	B6	3.95	7.4	0.66	4.2	2.61	10.9	10.9	-	-	-	-	-	

**PROPOSED DRAINAGE BASINS
STANDARD FORM SF-3
STORM DRAINAGE SYSTEM DESIGN
(RATIONAL METHOD PROCEDURE)**

PROJECT: COMPARK VILLAGE SOUTH, FILINGS 1 & 2
 CALCULATED BY: RAK DATE: November 18, 2016
 REVISED BY: asd DATE: July 20, 2020

Manning's n-value =0.013

CLCPKC3
 100-YEAR

Basin ID	Design Point	DIRECT RUNOFF					TOTAL RUNOFF				INLET		STORM SEWER			REMARKS
		Area (ac)	Tc (min.)	Runoff Coefficient, C	Intensity, I (in/hr)	C*A (Acres)	Direct Runoff, Q (cfs)	Tc (min.)	Intensity, I (in/hr)	C*A (Acres)	Total Runoff with Bypass, Q (cfs)	Intercepted (cfs)	Bypass (cfs)	Design Flow (cfs)	Slope (%)	
CVS-1 (Inlet 1-3)	1	3.85	6.9	0.65	8.0	2.51	20.2	12.1	2.51	20.2	13.5	6.7	22.5	3.1%	24	Bypass flow goes to CVS-3.
CVS-2 (Inlet 2-3)	2	1.42	6.6	0.85	8.1	1.21	9.9	12.1	1.21	9.9	9.0	1.0	9.0	10.0%	24	Bypass flow goes to CVS-4.
CVS-3 (Inlet 1-4)	3	0.94	6.2	0.76	8.3	0.71	5.9	12.1	0.71	12.6	7.7	4.9	7.7	1.7%	18	Takes bypass flow from CVS-1. Bypass goes to CVS-7.
CVS-4 (Inlet 2-4)	4	1.17	4.1	0.69	9.3	0.81	7.5	12.1	0.81	8.5	8.0	0.5	8.0	0.9%	18	Takes bypass flow from CVS-2. Bypass goes to CVS-8.
CVS-4A (Inlet 3-4)	4A	2.20	11.3	0.72	6.7	1.59	10.7			11.2	11.2	0.0	11.2	1.0%	18	Takes bypass flow from CVS-5.
CVS-5 (Inlet 5-4)	5	2.19	9.0	0.67	7.3	1.48	10.8	12.1	1.48	10.8	9.8	1.0	11.0	1.0%	18	Bypass flow goes to CVS-4A.
CVS-6 (Inlet 6-4)	6	0.58	5.0	0.67	8.8	0.39	3.5	12.1	0.39	3.5	3.5	0.0	51.3	1.7%	36	
CVS-6A (FES 2-4)	6A	0.78	5.0	0.46	8.8	0.36	3.2			3.2	3.2	0.0	51.0	3.1%	36	
CVS-7 (Inlet 1-6)	7	1.11	10.2	0.84	7.0	0.93	6.5	12.1	0.93	11.4	7.3	4.1	15.4	3.0%	24	Takes bypass flow from CVS-3. Bypass goes to CVS-11.
CVS-8 (Inlet 2-6)	8	1.59	10.1	0.72	7.0	1.15	8.1	12.1	1.15	8.6	8.1	0.5	8.1	1.4%	24	Takes bypass flow from CVS-4. Bypass goes to CVS-12.
CVS-9 (Inlet 4-5A)	9	2.41	11.9	0.72	6.5	1.74	11.4	12.1	1.74	11.6	10.2	1.4	10.2	1.2%	18	Bypass flow goes to CVS-12.
CVS-9A (Inlet 4-4)	9A	0.37	5.0	0.72	8.8	0.27	2.4			2.4	2.4	0.0	2.4	1.0%	18	
CVS-10 (Inlet 5-5A)	10	2.78	13.7	0.70	6.2	1.96	12.1	12.1	1.96	12.3	10.6	1.7	10.6	1.2%	18	Takes bypass flow from CVS-10A. Bypass flow goes to CVS-13B.
CVS-10A (Inlet 5-4A)	10A	0.40	5.8	0.76	8.5	0.31	2.6			2.6	2.2	0.4	2.2	1.0%	18	Bypass flow goes to CVS-10
CVS-11 (Inlet 1-5)	11	2.03	12.3	0.84	6.5	1.70	11.0	12.1	1.70	15.1	15.1	0.0	38.7	0.8%	36	Takes bypass flow from CVS-7. 1-31-20 Add Comm Interim
CVS-12 (Inlet 2-5)	12	4.58	11.9	0.72	6.6	3.31	21.7	12.1	3.31	23.6	23.6	0.0	23.6	0.7%	36	Takes bypass flow from CVS-8 and CVS-9.
CVS-12A (Inlet 3-5)	12	0.81	7.7	0.72	7.8	0.59	4.5			4.5	4.5	0.0	137.0	1.9%	42	
CVS-12B (Inlet 3-5)	12A	1.31	10.8	0.72	6.8	0.95	6.5			9.4	9.4	0.0	137.0	1.9%	42	
CVS-13 (Inlet 4-5)	13	1.16	7.4	0.72	7.9	0.84	6.6	12.1	0.84	8.9	8.9	0.0	8.9	3.6%	18	Takes bypass flow from CVS-13A and CVS 13C.
CVS 13A (Inlet 6-5A)	13A	1.20	8.7	0.76	7.4	0.91	6.7			6.7	6.2	0.5	6.2	1.0%	18	Bypass flow goes to CVS-13
CVS 13B (Inlet 4-5B)	13B	1.53	9.0	0.76	7.3	1.17	8.5			9.4	6.9	2.5	6.9	1.0%	18	Takes bypass flow from CVS-10. Bypass flow goes to CVS-13C.
CVS 13C (Inlet 4-5C)	13C	1.26	8.8	0.72	7.4	0.91	6.7			7.9	3.9	4.0	3.9	1.0%	18	Takes bypass flow from CVS 13B. Bypass flow goes to CVS-13
CVS-14 (Inlet 6-5)	14	1.89	11.1	0.72	6.7	1.37	9.2	12.1	1.37	10.1	10.1	0.0	54.4	3.2%	30	Takes bypass from CVS-14C
CVS-14A (Inlet 7-5)	14A	4.01	17.5	0.46	5.5	1.86	10.2			10.2	10.2	0.0	34.8	4.7%	24	
CVS-14B (Inlet 6-5)	14	2.73	13.4	0.49	6.2	1.35	8.4			9.5	9.5	0.0	54.4	3.4%	30	
CVS-14C (Inlet 5-5B)	14C	1.93	11.4	0.72	6.7	1.40	9.3			9.3	7.5	1.8	7.5	2.8%	18	Bypass flow goes to CVS-14
CVS-15 (Inlet 5-5)	15	2.01	13.4	0.72	6.2	1.45	9.0	12.1	1.45	9.1	9.1	0.0	9.1	5.0%	18	Takes bypass flow from CVS-15A
CVS-15A (Inlet 6-5B)	15A	0.95	7.9	0.74	7.7	0.71	5.4			5.4	5.3	0.1	5.3	1.0%	18	
CVS-16 (Inlet 2-11A)	16	1.37	10.0	0.72	7.0	0.99	7.0			7.0	6.4	0.6	6.4	5.2%	18	
CVS-17 (Inlet 2-11)	17	1.44	8.4	0.72	7.5	1.04	7.8			7.8	6.8	1.0	6.8	5.2%	18	
CVS-17A	17A	2.18	13.6	0.72	6.2	1.58	9.7									
CVS-18	18	2.69	10.0	0.70	7.0	1.88	13.2	12.1	1.88	-	-	-	-	-	-	
CVS-19	19	1.61	6.0	0.81	8.4	1.31	11.0	12.1	1.31	-	-	-	-	-	-	
CVS-20	20	1.80	10.4	0.72	6.9	1.30	9.0	12.1	1.30	-	-	-	-	-	-	
CVS-21	21	3.88	16.1	0.72	5.7	2.81	16.0	12.1	2.81	-	-	-	-	-	-	
CVS-22 (2-10A)	22	0.87	6.2	0.72	8.3	0.63	5.2			5.2	5.6	0.2	5.6	1.0%	18	Takes bypass flow from CVS-16
CVS-23 (Inlet 2-10)	23	0.87	5.5	0.82	8.6	0.71	6.1			6.1	7.1	0.5	6.1	1.0%	18	Takes bypass flow from CVS-17
BEL-1 (Inlet 2-1)	B1	3.73	12.8	0.62	6.3	2.31	14.7			14.7	8.3	6.4	63.6	3.3%	36	Bypass flow goes to BEL-3.
BEL-2 (Inlet 1-1)	B2	1.38	7.6	0.83	7.8	1.15	8.9			8.9	6.5	2.4	69.5	0.9%	36	Bypass flow goes to BEL-4.
BEL-3 (Inlet 2-2)	B3	6.76	14.4	0.56	6.0	3.76	22.6			29.0	29.0	0.0	95.6	3.2%	36	Takes bypass from BEL-1.
BEL-4 (Inlet 1-2)	B4	1.75	7.9	0.84	7.7	1.46	11.2			13.6	13.6	0.0	110.8	2.9%	36	Takes bypass from BEL-2.
BEL-5	B5	4.55	11.0	0.83	6.8	3.76	25.5	12.1	3.76	-	-	-	-	-	-	
BEL-6	B6	3.95	7.4	0.80	7.9	3.17	24.9	12.1	3.17	-	-	-	-	-	-	

APPENDIX C

Hydraulic Analysis

- Inlet Capacity Calculations
- StormCAD Storm Sewer Design
 - 2-Year Storm Table and Profiles
 - 5-Year Storm Table and Profiles
 - 100-Year Storm Table and Profiles
- Swale Calculations
- Water Quality Structure Cut Sheets & Calculations

**DESIGN PEAK FLOW FOR ONE-HALF OF STREET
OR GRASS-LINED CHANNEL BY THE RATIONAL METHOD**

Project: COMPARK SOUTH
Inlet ID: INLET 1-1

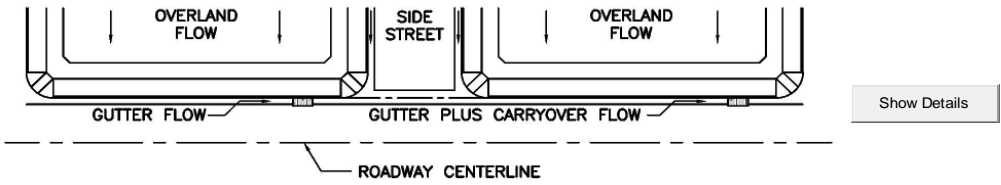

<p>Design Flow: ONLY if already determined through other methods: (local peak flow for 1/2 of street OR grass-lined channel):</p> <p>*Q_{known} = <input type="text" value="4.1"/> <input type="text" value="8.9"/> cfs</p> <p>* If you enter values in Row 14, skip the rest of this sheet and proceed to sheet Q-Allow or Area Inlet.</p>		<p><--- FILL IN THIS SECTION OR... FILL IN THE SECTIONS BELOW. <---</p>
<p>Geographic Information: (Enter data in the blue cells):</p> <div style="display: flex; justify-content: space-between;"> <div style="width: 30%;"> <p>Site Type:</p> <p><input type="radio"/> Site is Urban</p> <p><input type="radio"/> Site is Non-Urban</p> </div> <div style="width: 30%;"> <p>Flows Developed For:</p> <p><input type="radio"/> Street Inlets</p> <p><input type="radio"/> Area Inlets in a Median</p> </div> <div style="width: 30%;"> <p>Subcatchment Area = <input type="text"/> Acres</p> <p>Percent Imperviousness = <input type="text"/> %</p> <p>NRCS Soil Type = <input type="text"/> A, B, C, or D</p> </div> </div> <div style="display: flex; justify-content: space-between; margin-top: 10px;"> <div style="width: 45%;"> <p>Slope (ft/ft) Length (ft)</p> <p>Overland Flow = <input type="text"/> <input type="text"/></p> <p>Channel Flow = <input type="text"/> <input type="text"/></p> </div> </div>		
<p>Rainfall Information: Intensity I (inch/hr) = $C_1 * P_1 / (C_2 + T_c)^{C_3}$</p> <p>Design Storm Return Period, T_r = <input type="text"/> years</p> <p>Return Period One-Hour Precipitation, P₁ = <input type="text"/> inches</p> <p>C₁ = <input type="text"/></p> <p>C₂ = <input type="text"/></p> <p>C₃ = <input type="text"/></p> <p>User-Defined Storm Runoff Coefficient (leave this blank to accept a calculated value), C = <input type="text"/></p> <p>User-Defined 5-yr. Runoff Coefficient (leave this blank to accept a calculated value), C₅ = <input type="text"/></p> <p>Bypass (Carry-Over) Flow from upstream Subcatchments, Q_b = <input type="text" value="0.0"/> <input type="text" value="0.0"/> cfs</p> <p style="text-align: right;">Total Design Peak Flow, Q = <input type="text" value="4.1"/> <input type="text" value="8.9"/> cfs</p>		

ALLOWABLE CAPACITY FOR ONE-HALF OF STREET (Minor & Major Storm)

(Based on Regulated Criteria for Maximum Allowable Flow Depth and Spread)

Project: **COMPARK SOUTH**
 Inlet ID: **INLET 1-1**

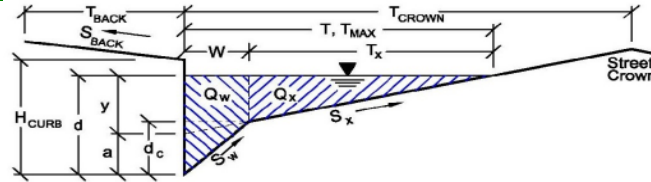

Gutter Geometry (Enter data in the blue cells)					
Maximum Allowable Width for Spread Behind Curb	$T_{BACK} = 17.5$ ft				
Side Slope Behind Curb (leave blank for no conveyance credit behind curb)	$S_{BACK} = 0.020$ ft/ft				
Manning's Roughness Behind Curb (typically between 0.012 and 0.020)	$n_{BACK} = 0.020$				
Height of Curb at Gutter Flow Line	$H_{CURB} = 6.00$ inches				
Distance from Curb Face to Street Crown	$T_{CROWN} = 37.0$ ft				
Gutter Width	$W = 2.00$ ft				
Street Transverse Slope	$S_x = 0.020$ ft/ft				
Gutter Cross Slope (typically 2 inches over 24 inches or 0.083 ft/ft)	$S_w = 0.083$ ft/ft				
Street Longitudinal Slope - Enter 0 for sump condition	$S_o = 0.019$ ft/ft				
Manning's Roughness for Street Section (typically between 0.012 and 0.020)	$n_{STREET} = 0.013$				
Max. Allowable Spread for Minor & Major Storm	<table border="1" style="display: inline-table; border-collapse: collapse;"> <tr> <th style="padding: 2px;">Minor Storm</th> <th style="padding: 2px;">Major Storm</th> </tr> <tr> <td style="text-align: center; padding: 2px;">$T_{MAX} = 20.0$</td> <td style="text-align: center; padding: 2px;">37.0</td> </tr> </table> ft	Minor Storm	Major Storm	$T_{MAX} = 20.0$	37.0
Minor Storm	Major Storm				
$T_{MAX} = 20.0$	37.0				
Max. Allowable Depth at Gutter Flowline for Minor & Major Storm	<table border="1" style="display: inline-table; border-collapse: collapse;"> <tr> <th style="padding: 2px;">Minor Storm</th> <th style="padding: 2px;">Major Storm</th> </tr> <tr> <td style="text-align: center; padding: 2px;">$d_{MAX} = 6.0$</td> <td style="text-align: center; padding: 2px;">12.0</td> </tr> </table> inches	Minor Storm	Major Storm	$d_{MAX} = 6.0$	12.0
Minor Storm	Major Storm				
$d_{MAX} = 6.0$	12.0				
Allow Flow Depth at Street Crown (leave blank for no)	<table style="display: inline-table; border-collapse: collapse;"> <tr> <td style="text-align: center; padding: 2px;"><input type="checkbox"/></td> <td style="text-align: center; padding: 2px;"><input checked="" type="checkbox"/></td> <td style="padding: 2px;">check = yes</td> </tr> </table>	<input type="checkbox"/>	<input checked="" type="checkbox"/>	check = yes	
<input type="checkbox"/>	<input checked="" type="checkbox"/>	check = yes			
MINOR STORM Allowable Capacity is based on Depth Criterion					
MAJOR STORM Allowable Capacity is based on Depth Criterion					
Minor storm max. allowable capacity GOOD - greater than flow given on sheet 'Q-Peak'	$Q_{allow} = 23.4$ cfs				
Major storm max. allowable capacity GOOD - greater than flow given on sheet 'Q-Peak'	207.0 cfs				

INLET ON A CONTINUOUS GRADE

Project: COMPARK SOUTH
 Inlet ID: INLET 1-1

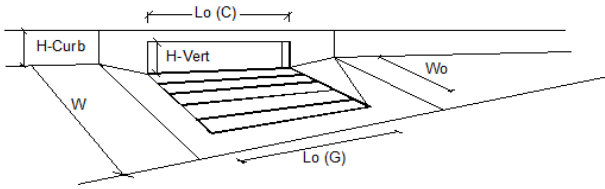

Design Information (Input)	MINOR		MAJOR		
	MINOR	MAJOR	MINOR	MAJOR	
Type of Inlet	Type = CDOT Type R Curb Opening				
Local Depression (additional to continuous gutter depression 'a' from 'Q-Allow')	$a_{LOCAL} = 3.0$	3.0			inches
Total Number of Units in the Inlet (Grate or Curb Opening)	$N_o = 2$	2			
Length of a Single Unit Inlet (Grate or Curb Opening)	$L_o = 5.00$	5.00			ft
Width of a Unit Grate (cannot be greater than W from Q-Allow)	$W_o = N/A$	N/A			ft
Clogging Factor for a Single Unit Grate (typical min. value = 0.5)	$C_r-G = N/A$	N/A			
Clogging Factor for a Single Unit Curb Opening (typical min. value = 0.1)	$C_r-C = 0.10$	0.10			
Street Hydraulics: OK - $Q < Q_{max}$ allowable from sheet 'Q-Allow'					
Total Inlet Interception Capacity	$Q = 3.98$	6.47			cfs
Total Inlet Carry-Over Flow (flow bypassing inlet)	$Q_b = 0.1$	2.4			cfs
Capture Percentage = $Q_g/Q_o =$	$C\% = 97$	73			%

**DESIGN PEAK FLOW FOR ONE-HALF OF STREET
OR GRASS-LINED CHANNEL BY THE RATIONAL METHOD**

Project: COMPARK SOUTH
Inlet ID: INLET 1-2

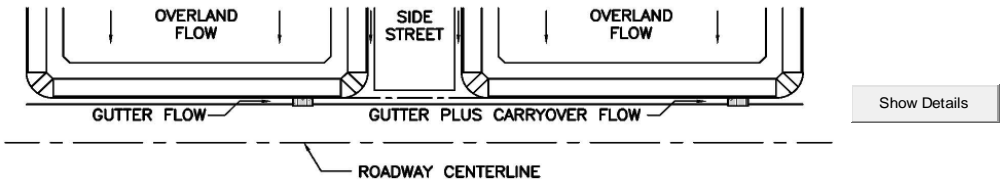

Design Flow: ONLY if already determined through other methods: (local peak flow for 1/2 of street OR grass-lined channel):		* Q_{known} =	<table border="1" style="display: inline-table; border-collapse: collapse;"> <tr> <td style="width: 50px;">Minor Storm</td> <td style="width: 50px;">Major Storm</td> </tr> <tr> <td style="text-align: center;">5.2</td> <td style="text-align: center;">11.2</td> </tr> </table> cfs	Minor Storm	Major Storm	5.2	11.2	<--- FILL IN THIS SECTION OR... FILL IN THE SECTIONS BELOW. <---
Minor Storm	Major Storm							
5.2	11.2							
Geographic Information: (Enter data in the blue cells):		Subcatchment Area = <input style="width: 50px;" type="text"/> Acres Percent Imperviousness = <input style="width: 50px;" type="text"/> % NRCS Soil Type = <input style="width: 50px;" type="text"/> A, B, C, or D						
Site Type:	Flows Developed For:	Slope (ft/ft)	Length (ft)					
<input type="radio"/> Site is Urban <input type="radio"/> Site is Non-Urban	<input type="radio"/> Street Inlets <input type="radio"/> Area Inlets in a Median	Overland Flow = <input style="width: 50px;" type="text"/>	Channel Flow = <input style="width: 50px;" type="text"/>					
Rainfall Information: Intensity I (inch/hr) = $C_1 * P_1 / (C_2 + T_c)^{C_3}$		Design Storm Return Period, T_r =	<table border="1" style="display: inline-table; border-collapse: collapse;"> <tr> <td style="width: 50px;">Minor Storm</td> <td style="width: 50px;">Major Storm</td> </tr> <tr> <td style="text-align: center;"> </td> <td style="text-align: center;"> </td> </tr> </table> years	Minor Storm	Major Storm			
Minor Storm	Major Storm							
		Return Period One-Hour Precipitation, P_1 =	<input style="width: 50px;" type="text"/>	inches				
		C_1 =	<input style="width: 50px;" type="text"/>					
		C_2 =	<input style="width: 50px;" type="text"/>					
		C_3 =	<input style="width: 50px;" type="text"/>					
User-Defined Storm Runoff Coefficient (leave this blank to accept a calculated value), C =		<input style="width: 50px;" type="text"/>						
User-Defined 5-yr. Runoff Coefficient (leave this blank to accept a calculated value), C_5 =		<input style="width: 50px;" type="text"/>						
		Bypass (Carry-Over) Flow from upstream Subcatchments, Q_b =	<table border="1" style="display: inline-table; border-collapse: collapse;"> <tr> <td style="width: 50px;">0.0</td> <td style="width: 50px;">2.4</td> </tr> </table> cfs	0.0	2.4			
0.0	2.4							
		Total Design Peak Flow, Q =	<table border="1" style="display: inline-table; border-collapse: collapse;"> <tr> <td style="width: 50px;">5.2</td> <td style="width: 50px;">13.6</td> </tr> </table> cfs	5.2	13.6			
5.2	13.6							

ALLOWABLE CAPACITY FOR ONE-HALF OF STREET (Minor & Major Storm)

(Based on Regulated Criteria for Maximum Allowable Flow Depth and Spread)

Project:
Inlet ID:

COMPARK SOUTH
INLET 1-2

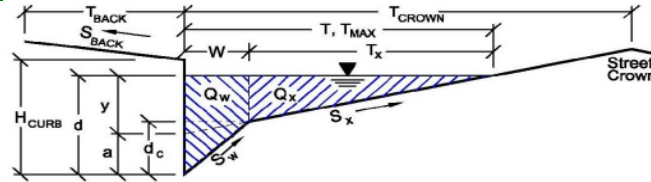

Gutter Geometry (Enter data in the blue cells)					
Maximum Allowable Width for Spread Behind Curb	$T_{BACK} = 17.5$ ft				
Side Slope Behind Curb (leave blank for no conveyance credit behind curb)	$S_{BACK} = 0.020$ ft/ft				
Manning's Roughness Behind Curb (typically between 0.012 and 0.020)	$n_{BACK} = 0.020$				
Height of Curb at Gutter Flow Line	$H_{CURB} = 6.00$ inches				
Distance from Curb Face to Street Crown	$T_{CROWN} = 37.0$ ft				
Gutter Width	$W = 2.00$ ft				
Street Transverse Slope	$S_x = 0.020$ ft/ft				
Gutter Cross Slope (typically 2 inches over 24 inches or 0.083 ft/ft)	$S_w = 0.083$ ft/ft				
Street Longitudinal Slope - Enter 0 for sump condition	$S_o = 0.000$ ft/ft				
Manning's Roughness for Street Section (typically between 0.012 and 0.020)	$n_{STREET} = 0.013$				
Max. Allowable Spread for Minor & Major Storm	<table border="1" style="display: inline-table; border-collapse: collapse;"> <tr> <td style="text-align: center;">Minor Storm</td> <td style="text-align: center;">Major Storm</td> </tr> <tr> <td style="text-align: center;">$T_{MAX} = 20.0$</td> <td style="text-align: center;">$T_{MAX} = 37.0$</td> </tr> </table> ft	Minor Storm	Major Storm	$T_{MAX} = 20.0$	$T_{MAX} = 37.0$
Minor Storm	Major Storm				
$T_{MAX} = 20.0$	$T_{MAX} = 37.0$				
Max. Allowable Depth at Gutter Flowline for Minor & Major Storm	<table border="1" style="display: inline-table; border-collapse: collapse;"> <tr> <td style="text-align: center;">Minor Storm</td> <td style="text-align: center;">Major Storm</td> </tr> <tr> <td style="text-align: center;">$d_{MAX} = 6.0$</td> <td style="text-align: center;">$d_{MAX} = 12.0$</td> </tr> </table> inches	Minor Storm	Major Storm	$d_{MAX} = 6.0$	$d_{MAX} = 12.0$
Minor Storm	Major Storm				
$d_{MAX} = 6.0$	$d_{MAX} = 12.0$				
Allow Flow Depth at Street Crown (leave blank for no)	<table style="display: inline-table; border-collapse: collapse;"> <tr> <td style="text-align: center;"><input type="checkbox"/></td> <td style="text-align: center;"><input checked="" type="checkbox"/></td> <td style="padding-left: 10px;">check = yes</td> </tr> </table>	<input type="checkbox"/>	<input checked="" type="checkbox"/>	check = yes	
<input type="checkbox"/>	<input checked="" type="checkbox"/>	check = yes			
MINOR STORM Allowable Capacity is based on Depth Criterion					
MAJOR STORM Allowable Capacity is based on Depth Criterion					
Minor storm max. allowable capacity GOOD - greater than flow given on sheet 'Q-Peak'					
Major storm max. allowable capacity GOOD - greater than flow given on sheet 'Q-Peak'					
$Q_{allow} =$	<table border="1" style="display: inline-table; border-collapse: collapse;"> <tr> <td style="text-align: center;">Minor Storm</td> <td style="text-align: center;">Major Storm</td> </tr> <tr> <td style="text-align: center;">SUMP</td> <td style="text-align: center;">SUMP</td> </tr> </table> cfs	Minor Storm	Major Storm	SUMP	SUMP
Minor Storm	Major Storm				
SUMP	SUMP				

INLET IN A SUMP OR SAG LOCATION

Project = **COMPARK SOUTH**
 Inlet ID = **INLET 1-2**

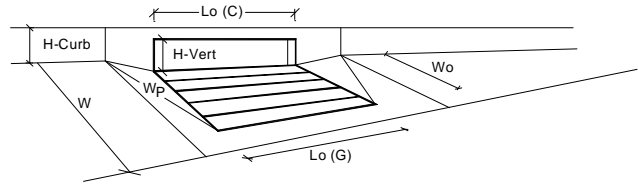

Design Information (Input)	MINOR		MAJOR	
	Type of Inlet	CDOT Type R Curb Opening		
Local Depression (additional to continuous gutter depression 'a' from 'Q-Allow')	a _{local} =	3.00	3.00	inches
Number of Unit Inlets (Grate or Curb Opening)	No =	2	2	
Water Depth at Flowline (outside of local depression)	Ponding Depth =	6.0	10.4	inches
Grate Information	<input type="checkbox"/> Override Depths			
Length of a Unit Grate	L _o (G) =	N/A	N/A	feet
Width of a Unit Grate	W _o =	N/A	N/A	feet
Area Opening Ratio for a Grate (typical values 0.15-0.90)	A _{ratio} =	N/A	N/A	
Clogging Factor for a Single Grate (typical value 0.50 - 0.70)	C _r (G) =	N/A	N/A	
Grate Weir Coefficient (typical value 2.15 - 3.60)	C _w (G) =	N/A	N/A	
Grate Orifice Coefficient (typical value 0.60 - 0.80)	C _o (G) =	N/A	N/A	
Curb Opening Information				
Length of a Unit Curb Opening	L _o (C) =	5.00	5.00	feet
Height of Vertical Curb Opening in Inches	H _{vert} =	6.00	6.00	inches
Height of Curb Orifice Throat in Inches	H _{throat} =	6.00	6.00	inches
Angle of Throat (see USDCM Figure ST-5)	Theta =	63.40	63.40	degrees
Side Width for Depression Pan (typically the gutter width of 2 feet)	W _p =	2.00	2.00	feet
Clogging Factor for a Single Curb Opening (typical value 0.10)	C _r (C) =	0.10	0.10	
Curb Opening Weir Coefficient (typical value 2.3-3.7)	C _w (C) =	3.60	3.60	
Curb Opening Orifice Coefficient (typical value 0.60 - 0.70)	C _o (C) =	0.67	0.67	
Total Inlet Interception Capacity (assumes clogged condition)				
Inlet Capacity IS GOOD for Minor and Major Storms (>Q PEAK)	Q _a =	10.5	23.8	cfs
	Q _{PEAK REQUIRED} =	5.2	13.6	cfs

**DESIGN PEAK FLOW FOR ONE-HALF OF STREET
OR GRASS-LINED CHANNEL BY THE RATIONAL METHOD**

Project: COMPARK SOUTH
Inlet ID: INLET 1-3

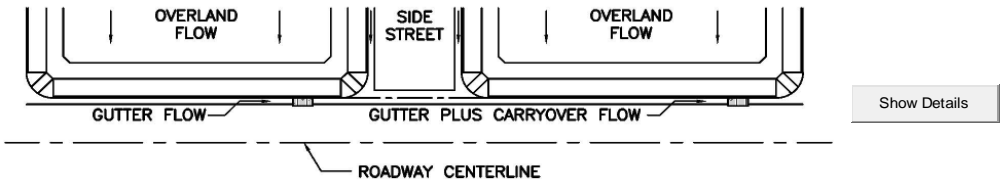

Design Flow: ONLY if already determined through other methods: (local peak flow for 1/2 of street OR grass-lined channel):		* Q_{known} = <table border="1" style="display: inline-table; border-collapse: collapse;"> <tr> <td style="width: 50px; text-align: center;">Minor Storm</td> <td style="width: 50px; text-align: center;">Major Storm</td> </tr> <tr> <td style="text-align: center;">5.5</td> <td style="text-align: center;">20.2</td> </tr> </table> cfs	Minor Storm	Major Storm	5.5	20.2	<--- FILL IN THIS SECTION OR... FILL IN THE SECTIONS BELOW. <---
Minor Storm	Major Storm						
5.5	20.2						
* If you enter values in Row 14, skip the rest of this sheet and proceed to sheet Q-Allow or Area Inlet.							
Geographic Information: (Enter data in the blue cells):							
Site Type:	Flows Developed For:	Subcatchment Area = <input type="text"/> Acres					
<input type="radio"/> Site is Urban <input type="radio"/> Site is Non-Urban	<input type="radio"/> Street Inlets <input type="radio"/> Area Inlets in a Median	Percent Imperviousness = <input type="text"/> % NRCS Soil Type = <input type="text"/> A, B, C, or D					
		Slope (ft/ft) Length (ft)					
		Overland Flow = <input type="text"/>					
		Channel Flow = <input type="text"/>					
Rainfall Information: Intensity I (inch/hr) = $C_1 * P_1 / (C_2 + T_c)^{C_3}$							
		Design Storm Return Period, T_r = <input type="text"/> years					
		Return Period One-Hour Precipitation, P_1 = <input type="text"/> inches					
		C_1 = <input type="text"/>					
		C_2 = <input type="text"/>					
		C_3 = <input type="text"/>					
User-Defined Storm Runoff Coefficient (leave this blank to accept a calculated value), C = <input type="text"/>							
User-Defined 5-yr. Runoff Coefficient (leave this blank to accept a calculated value), C_5 = <input type="text"/>							
		Bypass (Carry-Over) Flow from upstream Subcatchments, Q_b = <table border="1" style="display: inline-table; border-collapse: collapse;"> <tr> <td style="width: 50px; text-align: center;">Minor Storm</td> <td style="width: 50px; text-align: center;">Major Storm</td> </tr> <tr> <td style="text-align: center;">0.0</td> <td style="text-align: center;">0.0</td> </tr> </table> cfs	Minor Storm	Major Storm	0.0	0.0	
Minor Storm	Major Storm						
0.0	0.0						
		Total Design Peak Flow, Q = <table border="1" style="display: inline-table; border-collapse: collapse;"> <tr> <td style="width: 50px; text-align: center;">Minor Storm</td> <td style="width: 50px; text-align: center;">Major Storm</td> </tr> <tr> <td style="text-align: center;">5.5</td> <td style="text-align: center;">20.2</td> </tr> </table> cfs	Minor Storm	Major Storm	5.5	20.2	
Minor Storm	Major Storm						
5.5	20.2						

ALLOWABLE CAPACITY FOR ONE-HALF OF STREET (Minor & Major Storm)

(Based on Regulated Criteria for Maximum Allowable Flow Depth and Spread)

Project: **COMPARK SOUTH**
 Inlet ID: **INLET 1-3**

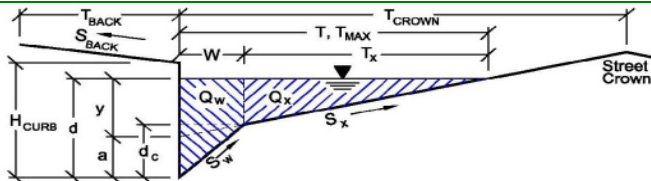

Gutter Geometry (Enter data in the blue cells)			
Maximum Allowable Width for Spread Behind Curb	T _{BACK} = 17.5 ft		
Side Slope Behind Curb (leave blank for no conveyance credit behind curb)	S _{BACK} = 0.020 ft/ft		
Manning's Roughness Behind Curb (typically between 0.012 and 0.020)	n _{BACK} = 0.020		
Height of Curb at Gutter Flow Line	H _{CURB} = 6.00 inches		
Distance from Curb Face to Street Crown	T _{CROWN} = 37.0 ft		
Gutter Width	W = 2.00 ft		
Street Transverse Slope	S _X = 0.020 ft/ft		
Gutter Cross Slope (typically 2 inches over 24 inches or 0.083 ft/ft)	S _W = 0.083 ft/ft		
Street Longitudinal Slope - Enter 0 for sump condition	S _O = 0.019 ft/ft		
Manning's Roughness for Street Section (typically between 0.012 and 0.020)	n _{STREET} = 0.013		
Max. Allowable Spread for Minor & Major Storm	T _{MAX} = <table border="1"><tr><td>20.0</td><td>37.0</td></tr></table> ft	20.0	37.0
20.0	37.0		
Max. Allowable Depth at Gutter Flowline for Minor & Major Storm	d _{MAX} = <table border="1"><tr><td>6.0</td><td>12.0</td></tr></table> inches	6.0	12.0
6.0	12.0		
Allow Flow Depth at Street Crown (leave blank for no)	<input type="checkbox"/> <input checked="" type="checkbox"/> check = yes		
MINOR STORM Allowable Capacity is based on Depth Criterion			
MAJOR STORM Allowable Capacity is based on Depth Criterion			
Q _{allow} =	<table border="1"><tr><td>23.4</td><td>207.0</td></tr></table> cfs	23.4	207.0
23.4	207.0		
Minor storm max. allowable capacity GOOD - greater than flow given on sheet 'Q-Peak'			
Major storm max. allowable capacity GOOD - greater than flow given on sheet 'Q-Peak'			

INLET ON A CONTINUOUS GRADE

Project: COMPARK SOUTH
 Inlet ID: INLET 1-3

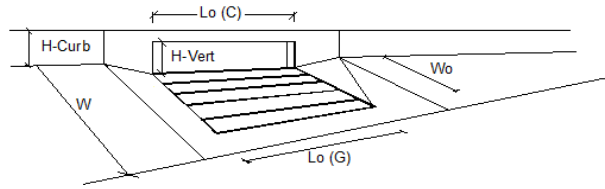

Design Information (Input)	MINOR		MAJOR		
Type of Inlet	Type = CDOT Type R Curb Opening				
Local Depression (additional to continuous gutter depression 'a' from 'Q-Allow')	$a_{LOCAL} =$	3.0	3.0		inches
Total Number of Units in the Inlet (Grate or Curb Opening)	$N_o =$	3	3		
Length of a Single Unit Inlet (Grate or Curb Opening)	$L_o =$	5.00	5.00		ft
Width of a Unit Grate (cannot be greater than W from Q-Allow)	$W_o =$	N/A	N/A		ft
Clogging Factor for a Single Unit Grate (typical min. value = 0.5)	$C_r-G =$	N/A	N/A		
Clogging Factor for a Single Unit Curb Opening (typical min. value = 0.1)	$C_r-C =$	0.10	0.10		
Street Hydraulics: OK - $Q <$ maximum allowable from sheet 'Q-Allow'					
Total Inlet Interception Capacity	$Q =$	5.50	13.47		cfs
Total Inlet Carry-Over Flow (flow bypassing inlet)	$Q_b =$	0.0	6.7		cfs
Capture Percentage = $Q_i/Q_o =$	$C\% =$	100	67		%

**DESIGN PEAK FLOW FOR ONE-HALF OF STREET
OR GRASS-LINED CHANNEL BY THE RATIONAL METHOD**

Project: COMPARK SOUTH
Inlet ID: INLET 1-4

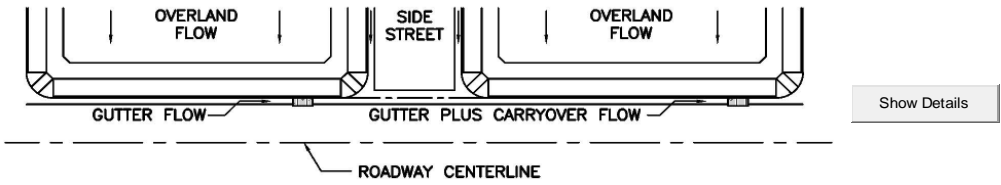

<p>Design Flow: ONLY if already determined through other methods: (local peak flow for 1/2 of street OR grass-lined channel):</p> <p>*Q_{known} = <input type="text" value="2.4"/> <input type="text" value="5.9"/> cfs</p> <p>* If you enter values in Row 14, skip the rest of this sheet and proceed to sheet Q-Allow or Area Inlet.</p>		<p><--- FILL IN THIS SECTION OR... FILL IN THE SECTIONS BELOW. <---</p>
<p>Geographic Information: (Enter data in the blue cells):</p> <div style="display: flex; justify-content: space-between;"> <div style="width: 30%;"> <p>Site Type:</p> <p><input type="radio"/> Site is Urban</p> <p><input type="radio"/> Site is Non-Urban</p> </div> <div style="width: 30%;"> <p>Flows Developed For:</p> <p><input type="radio"/> Street Inlets</p> <p><input type="radio"/> Area Inlets in a Median</p> </div> <div style="width: 30%;"> <p>Subcatchment Area = <input type="text"/> Acres</p> <p>Percent Imperviousness = <input type="text"/> %</p> <p>NRCS Soil Type = <input type="text"/> A, B, C, or D</p> </div> </div> <div style="display: flex; justify-content: space-between; margin-top: 10px;"> <div style="width: 45%;"> <p>Slope (ft/ft) Length (ft)</p> <p>Overland Flow = <input type="text"/> <input type="text"/></p> <p>Channel Flow = <input type="text"/> <input type="text"/></p> </div> </div>		
<p>Rainfall Information: Intensity I (inch/hr) = $C_1 * P_1 / (C_2 + I_c)^{C_3}$</p> <p>Design Storm Return Period, T_r = <input type="text"/> years</p> <p>Return Period One-Hour Precipitation, P₁ = <input type="text"/> inches</p> <p>C₁ = <input type="text"/></p> <p>C₂ = <input type="text"/></p> <p>C₃ = <input type="text"/></p> <p>User-Defined Storm Runoff Coefficient (leave this blank to accept a calculated value), C = <input type="text"/></p> <p>User-Defined 5-yr. Runoff Coefficient (leave this blank to accept a calculated value), C₅ = <input type="text"/></p> <p>Bypass (Carry-Over) Flow from upstream Subcatchments, Q_b = <input type="text" value="0.0"/> <input type="text" value="6.7"/> cfs</p> <p>Total Design Peak Flow, Q = <input type="text" value="2.4"/> <input type="text" value="12.6"/> cfs</p>		

ALLOWABLE CAPACITY FOR ONE-HALF OF STREET (Minor & Major Storm)

(Based on Regulated Criteria for Maximum Allowable Flow Depth and Spread)

Project: **COMPARK SOUTH**
 Inlet ID: **INLET 1-4**

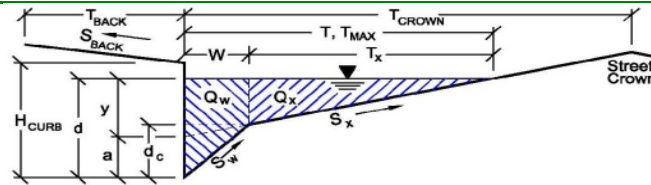

Gutter Geometry (Enter data in the blue cells)						
Maximum Allowable Width for Spread Behind Curb	$T_{BACK} =$	17.5 ft				
Side Slope Behind Curb (leave blank for no conveyance credit behind curb)	$S_{BACK} =$	0.020 ft/ft				
Manning's Roughness Behind Curb (typically between 0.012 and 0.020)	$n_{BACK} =$	0.020				
Height of Curb at Gutter Flow Line	$H_{CURB} =$	6.00 inches				
Distance from Curb Face to Street Crown	$T_{CROWN} =$	37.0 ft				
Gutter Width	$W =$	2.00 ft				
Street Transverse Slope	$S_x =$	0.020 ft/ft				
Gutter Cross Slope (typically 2 inches over 24 inches or 0.083 ft/ft)	$S_w =$	0.083 ft/ft				
Street Longitudinal Slope - Enter 0 for sump condition	$S_o =$	0.019 ft/ft				
Manning's Roughness for Street Section (typically between 0.012 and 0.020)	$n_{STREET} =$	0.013				
Max. Allowable Spread for Minor & Major Storm	$T_{MAX} =$	<table border="1" style="display: inline-table; border-collapse: collapse;"> <thead> <tr> <th style="padding: 2px;">Minor Storm</th> <th style="padding: 2px;">Major Storm</th> </tr> </thead> <tbody> <tr> <td style="text-align: center; padding: 2px;">20.0</td> <td style="text-align: center; padding: 2px;">37.0</td> </tr> </tbody> </table> ft	Minor Storm	Major Storm	20.0	37.0
Minor Storm	Major Storm					
20.0	37.0					
Max. Allowable Depth at Gutter Flowline for Minor & Major Storm	$d_{MAX} =$	<table border="1" style="display: inline-table; border-collapse: collapse;"> <thead> <tr> <th style="padding: 2px;">Minor Storm</th> <th style="padding: 2px;">Major Storm</th> </tr> </thead> <tbody> <tr> <td style="text-align: center; padding: 2px;">6.0</td> <td style="text-align: center; padding: 2px;">12.0</td> </tr> </tbody> </table> inches	Minor Storm	Major Storm	6.0	12.0
Minor Storm	Major Storm					
6.0	12.0					
Allow Flow Depth at Street Crown (leave blank for no)		<input type="checkbox"/> Minor Storm <input checked="" type="checkbox"/> Major Storm check = yes				
MINOR STORM Allowable Capacity is based on Depth Criterion						
MAJOR STORM Allowable Capacity is based on Depth Criterion						
	$Q_{allow} =$	<table border="1" style="display: inline-table; border-collapse: collapse;"> <thead> <tr> <th style="padding: 2px;">Minor Storm</th> <th style="padding: 2px;">Major Storm</th> </tr> </thead> <tbody> <tr> <td style="text-align: center; padding: 2px;">23.4</td> <td style="text-align: center; padding: 2px;">207.0</td> </tr> </tbody> </table> cfs	Minor Storm	Major Storm	23.4	207.0
Minor Storm	Major Storm					
23.4	207.0					
Minor storm max. allowable capacity GOOD - greater than flow given on sheet 'Q-Peak' Major storm max. allowable capacity GOOD - greater than flow given on sheet 'Q-Peak'						

INLET ON A CONTINUOUS GRADE

Project: COMPARK SOUTH
 Inlet ID: INLET 1-4

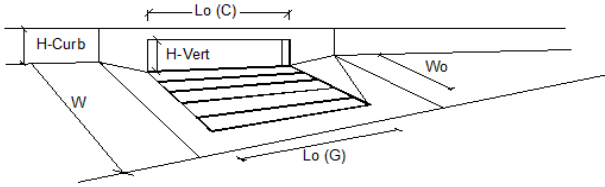

Design Information (Input)	MINOR		MAJOR		
	Type = CDOT Type R Curb Opening				
Type of Inlet	CDOT Type R Curb Opening				
Local Depression (additional to continuous gutter depression 'a' from 'Q-Allow')	$a_{LOCAL} =$	3.0	3.0		inches
Total Number of Units in the Inlet (Grate or Curb Opening)	$N_o =$	2	2		
Length of a Single Unit Inlet (Grate or Curb Opening)	$L_o =$	5.00	5.00		ft
Width of a Unit Grate (cannot be greater than W from Q-Allow)	$W_o =$	N/A	N/A		ft
Clogging Factor for a Single Unit Grate (typical min. value = 0.5)	$C_r-G =$	N/A	N/A		
Clogging Factor for a Single Unit Curb Opening (typical min. value = 0.1)	$C_r-C =$	0.10	0.10		
Street Hydraulics: OK - $Q <$ maximum allowable from sheet 'Q-Allow'					
Total Inlet Interception Capacity	$Q =$	2.40	7.70		cfs
Total Inlet Carry-Over Flow (flow bypassing inlet)	$Q_b =$	0.0	4.9		cfs
Capture Percentage = $Q_i/Q_o =$	$C\% =$	100	61		%

**DESIGN PEAK FLOW FOR ONE-HALF OF STREET
OR GRASS-LINED CHANNEL BY THE RATIONAL METHOD**

Project: COMPARK SOUTH
Inlet ID: INLET 1-5

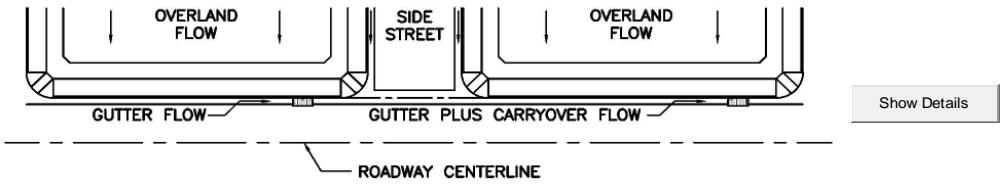

<p>Design Flow: ONLY if already determined through other methods: (local peak flow for 1/2 of street OR grass-lined channel):</p> <p>*Q_{known} = <input type="text" value="5.1"/> <input type="text" value="11.0"/> cfs</p> <p>* If you enter values in Row 14, skip the rest of this sheet and proceed to sheet Q-Allow or Area Inlet.</p>		<p><--- FILL IN THIS SECTION OR... FILL IN THE SECTIONS BELOW. <---</p>
<p>Geographic Information: (Enter data in the blue cells):</p> <div style="display: flex; justify-content: space-between;"> <div style="width: 30%;"> <p>Site Type:</p> <p><input type="radio"/> Site is Urban</p> <p><input type="radio"/> Site is Non-Urban</p> </div> <div style="width: 30%;"> <p>Flows Developed For:</p> <p><input type="radio"/> Street Inlets</p> <p><input type="radio"/> Area Inlets in a Median</p> </div> <div style="width: 30%;"> <p>Subcatchment Area = <input type="text"/> Acres</p> <p>Percent Imperviousness = <input type="text"/> %</p> <p>NRCS Soil Type = <input type="text"/> A, B, C, or D</p> </div> </div> <div style="display: flex; justify-content: space-between; margin-top: 10px;"> <div style="width: 45%;"> <p>Slope (ft/ft) Length (ft)</p> <p>Overland Flow = <input type="text"/> <input type="text"/></p> <p>Channel Flow = <input type="text"/> <input type="text"/></p> </div> </div>		
<p>Rainfall Information: Intensity I (inch/hr) = $C_1 * P_1 / (C_2 + I_c)^{C_3}$</p> <p>Design Storm Return Period, T_r = <input type="text"/> years</p> <p>Return Period One-Hour Precipitation, P₁ = <input type="text"/> inches</p> <p>C₁ = <input type="text"/></p> <p>C₂ = <input type="text"/></p> <p>C₃ = <input type="text"/></p> <p>User-Defined Storm Runoff Coefficient (leave this blank to accept a calculated value), C = <input type="text"/></p> <p>User-Defined 5-yr. Runoff Coefficient (leave this blank to accept a calculated value), C₅ = <input type="text"/></p> <p>Bypass (Carry-Over) Flow from upstream Subcatchments, Q_b = <input type="text" value="0.0"/> <input type="text" value="4.1"/> cfs</p> <p>Total Design Peak Flow, Q = <input type="text" value="5.1"/> <input type="text" value="15.1"/> cfs</p>		

ALLOWABLE CAPACITY FOR ONE-HALF OF STREET (Minor & Major Storm)

(Based on Regulated Criteria for Maximum Allowable Flow Depth and Spread)

Project:
Inlet ID:

COMPARK SOUTH
INLET 1-5

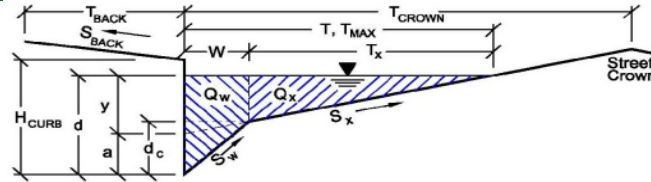

Gutter Geometry (Enter data in the blue cells)

Maximum Allowable Width for Spread Behind Curb $T_{BACK} = 17.5$ ft

Side Slope Behind Curb (leave blank for no conveyance credit behind curb) $S_{BACK} = 0.020$ ft/ft

Manning's Roughness Behind Curb (typically between 0.012 and 0.020) $n_{BACK} = 0.020$

Height of Curb at Gutter Flow Line $H_{CURB} = 6.00$ inches

Distance from Curb Face to Street Crown $T_{CROWN} = 37.0$ ft

Gutter Width $W = 2.00$ ft

Street Transverse Slope $S_x = 0.020$ ft/ft

Gutter Cross Slope (typically 2 inches over 24 inches or 0.083 ft/ft) $S_w = 0.083$ ft/ft

Street Longitudinal Slope - Enter 0 for sump condition $S_o = 0.000$ ft/ft

Manning's Roughness for Street Section (typically between 0.012 and 0.020) $n_{STREET} = 0.013$

	Minor Storm	Major Storm	
Max. Allowable Spread for Minor & Major Storm $T_{MAX} =$	20.0	37.0	ft
Max. Allowable Depth at Gutter Flowline for Minor & Major Storm $d_{MAX} =$	6.0	12.0	inches
Allow Flow Depth at Street Crown (leave blank for no)	<input type="checkbox"/>	<input checked="" type="checkbox"/>	check = yes

MINOR STORM Allowable Capacity is based on Depth Criterion

MAJOR STORM Allowable Capacity is based on Depth Criterion

$Q_{allow} =$ Minor Storm Major Storm
SUMP SUMP cfs

Minor storm max. allowable capacity GOOD - greater than flow given on sheet 'Q-Peak'

Major storm max. allowable capacity GOOD - greater than flow given on sheet 'Q-Peak'

INLET IN A SUMP OR SAG LOCATION

Project = **COMPARK SOUTH**
 Inlet ID = **INLET 1-5**

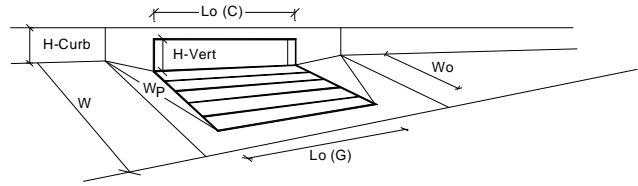

Design Information (Input)	MINOR		MAJOR	
	Type of Inlet	Inlet Type = CDOT Type R Curb Opening		
Local Depression (additional to continuous gutter depression 'a' from 'Q-Allow')	$a_{local} =$	3.00	3.00	inches
Number of Unit Inlets (Grate or Curb Opening)	$N_o =$	2	2	
Water Depth at Flowline (outside of local depression)	Ponding Depth =	6.0	10.4	inches
Grate Information	<input type="checkbox"/> Override Depths			
Length of a Unit Grate	$L_o (G) =$	N/A	N/A	feet
Width of a Unit Grate	$W_o =$	N/A	N/A	feet
Area Opening Ratio for a Grate (typical values 0.15-0.90)	$A_{ratio} =$	N/A	N/A	
Clogging Factor for a Single Grate (typical value 0.50 - 0.70)	$C_r (G) =$	N/A	N/A	
Grate Weir Coefficient (typical value 2.15 - 3.60)	$C_w (G) =$	N/A	N/A	
Grate Orifice Coefficient (typical value 0.60 - 0.80)	$C_o (G) =$	N/A	N/A	
Curb Opening Information	MINOR		MAJOR	
Length of a Unit Curb Opening	$L_o (C) =$	5.00	5.00	feet
Height of Vertical Curb Opening in Inches	$H_{vert} =$	6.00	6.00	inches
Height of Curb Orifice Throat in Inches	$H_{throat} =$	6.00	6.00	inches
Angle of Throat (see USDCM Figure ST-5)	Theta =	63.40	63.40	degrees
Side Width for Depression Pan (typically the gutter width of 2 feet)	$W_p =$	2.00	2.00	feet
Clogging Factor for a Single Curb Opening (typical value 0.10)	$C_r (C) =$	0.10	0.10	
Curb Opening Weir Coefficient (typical value 2.3-3.7)	$C_w (C) =$	3.60	3.60	
Curb Opening Orifice Coefficient (typical value 0.60 - 0.70)	$C_o (C) =$	0.67	0.67	
Total Inlet Interception Capacity (assumes clogged condition)	MINOR		MAJOR	
	$Q_a =$	10.5	23.8	cfs
Inlet Capacity IS GOOD for Minor and Major Storms (>Q PEAK)	$Q_{PEAK REQUIRED} =$	5.1	15.1	cfs

**DESIGN PEAK FLOW FOR ONE-HALF OF STREET
OR GRASS-LINED CHANNEL BY THE RATIONAL METHOD**

Project: COMPARK SOUTH
 Inlet ID: INLET 1-6

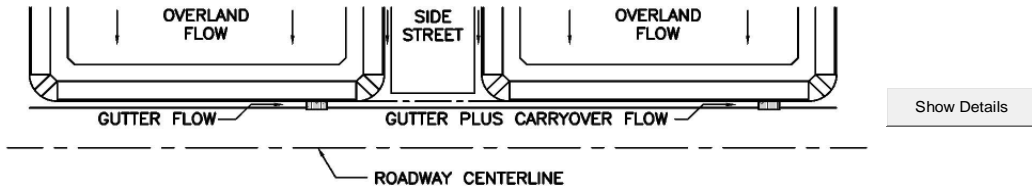

Design Flow: ONLY if already determined through other methods: (local peak flow for 1/2 of street OR grass-lined channel):		Minor Storm Major Storm * Q_{Known} = <input type="text" value="3.0"/> <input type="text" value="6.5"/> cfs	<--- FILL IN THIS SECTION OR... FILL IN THE SECTIONS BELOW. <---
* If you enter values in Row 14, skip the rest of this sheet and proceed to sheet Q-Allow or Area Inlet.			
Geographic Information: (Enter data in the blue cells):			
Site Type: <input type="radio"/> Site is Urban <input type="radio"/> Site is Non-Urban	Flows Developed For: <input type="radio"/> Street Inlets <input type="radio"/> Area Inlets in a Median	Subcatchment Area = <input type="text"/> Acres Percent Imperviousness = <input type="text"/> % NRCS Soil Type = <input type="text"/> A, B, C, or D	
		Slope (ft/ft) Length (ft) Overland Flow = <input type="text"/> <input type="text"/> Channel Flow = <input type="text"/> <input type="text"/>	
Rainfall Information: Intensity I (inch/hr) = $C_1 * P_1 / (C_2 + T_c) ^{C_3}$			
	Design Storm Return Period, T_r = <input type="text"/> years Return Period One-Hour Precipitation, P_1 = <input type="text"/> inches C_1 = <input type="text"/> C_2 = <input type="text"/> C_3 = <input type="text"/> User-Defined Storm Runoff Coefficient (leave this blank to accept a calculated value), C = <input type="text"/> User-Defined 5-yr. Runoff Coefficient (leave this blank to accept a calculated value), C_5 = <input type="text"/>	Minor Storm Major Storm Bypass (Carry-Over) Flow from upstream Subcatchments, Q_b = <input type="text" value="0.0"/> <input type="text" value="4.9"/> cfs	
	Total Design Peak Flow, Q = <input type="text" value="3.0"/> <input type="text" value="11.4"/> cfs		

ALLOWABLE CAPACITY FOR ONE-HALF OF STREET (Minor & Major Storm)

(Based on Regulated Criteria for Maximum Allowable Flow Depth and Spread)

Project:

COMPARK SOUTH

Inlet ID:

INLET 1-6

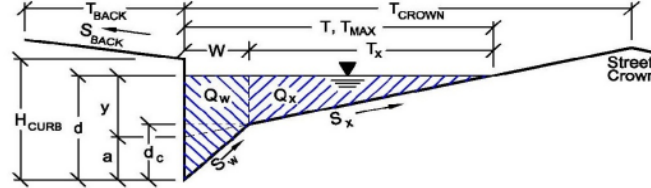

Gutter Geometry (Enter data in the blue cells)							
Maximum Allowable Width for Spread Behind Curb	$T_{BACK} = 17.5$ ft						
Side Slope Behind Curb (leave blank for no conveyance credit behind curb)	$S_{BACK} = 0.020$ ft/ft						
Manning's Roughness Behind Curb (typically between 0.012 and 0.020)	$n_{BACK} = 0.020$						
Height of Curb at Gutter Flow Line	$H_{CURB} = 6.00$ inches						
Distance from Curb Face to Street Crown	$T_{CROWN} = 37.0$ ft						
Gutter Width	$W = 2.00$ ft						
Street Transverse Slope	$S_x = 0.020$ ft/ft						
Gutter Cross Slope (typically 2 inches over 24 inches or 0.083 ft/ft)	$S_W = 0.083$ ft/ft						
Street Longitudinal Slope - Enter 0 for sump condition	$S_D = 0.010$ ft/ft						
Manning's Roughness for Street Section (typically between 0.012 and 0.020)	$n_{STREET} = 0.013$						
Max. Allowable Spread for Minor & Major Storm	<table border="1" style="display: inline-table; border-collapse: collapse;"> <thead> <tr> <th style="padding: 2px;">Minor Storm</th> <th style="padding: 2px;">Major Storm</th> <th style="padding: 2px;"></th> </tr> </thead> <tbody> <tr> <td style="text-align: center; padding: 2px;">$T_{MAX} = 20.0$</td> <td style="text-align: center; padding: 2px;">37.0</td> <td style="text-align: center; padding: 2px;">ft</td> </tr> </tbody> </table>	Minor Storm	Major Storm		$T_{MAX} = 20.0$	37.0	ft
Minor Storm	Major Storm						
$T_{MAX} = 20.0$	37.0	ft					
Max. Allowable Depth at Gutter Flowline for Minor & Major Storm	<table border="1" style="display: inline-table; border-collapse: collapse;"> <thead> <tr> <th style="padding: 2px;">Minor Storm</th> <th style="padding: 2px;">Major Storm</th> <th style="padding: 2px;"></th> </tr> </thead> <tbody> <tr> <td style="text-align: center; padding: 2px;">$d_{MAX} = 6.0$</td> <td style="text-align: center; padding: 2px;">12.0</td> <td style="text-align: center; padding: 2px;">inches</td> </tr> </tbody> </table>	Minor Storm	Major Storm		$d_{MAX} = 6.0$	12.0	inches
Minor Storm	Major Storm						
$d_{MAX} = 6.0$	12.0	inches					
Allow Flow Depth at Street Crown (leave blank for no)	<input type="checkbox"/> <input checked="" type="checkbox"/> check = yes						
MINOR STORM Allowable Capacity is based on Depth Criterion							
MAJOR STORM Allowable Capacity is based on Depth Criterion							
Minor storm max. allowable capacity GOOD - greater than flow given on sheet 'Q-Peak'							
Major storm max. allowable capacity GOOD - greater than flow given on sheet 'Q-Peak'							
	<table border="1" style="display: inline-table; border-collapse: collapse;"> <thead> <tr> <th style="padding: 2px;">Minor Storm</th> <th style="padding: 2px;">Major Storm</th> <th style="padding: 2px;"></th> </tr> </thead> <tbody> <tr> <td style="text-align: center; padding: 2px;">$Q_{allow} = 16.8$</td> <td style="text-align: center; padding: 2px;">171.1</td> <td style="text-align: center; padding: 2px;">cfs</td> </tr> </tbody> </table>	Minor Storm	Major Storm		$Q_{allow} = 16.8$	171.1	cfs
Minor Storm	Major Storm						
$Q_{allow} = 16.8$	171.1	cfs					

INLET ON A CONTINUOUS GRADE

Project: COMPARK SOUTH
 Inlet ID: INLET 1-6

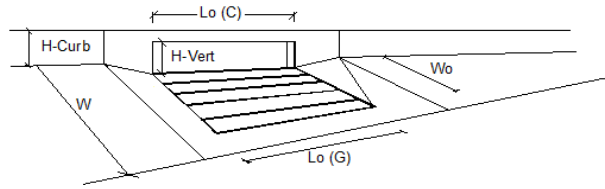

Design Information (Input)	MINOR		MAJOR	
	Type of Inlet	Type = CDOT Type R Curb Opening		
Local Depression (additional to continuous gutter depression 'a' from 'Q-Allow')	$a_{LOCAL} = 3.0$	3.0	inches	
Total Number of Units in the Inlet (Grate or Curb Opening)	$N_o = 2$	2		
Length of a Single Unit Inlet (Grate or Curb Opening)	$L_o = 5.00$	5.00	ft	
Width of a Unit Grate (cannot be greater than W from Q-Allow)	$W_o = N/A$	N/A	ft	
Clogging Factor for a Single Unit Grate (typical min. value = 0.5)	$C_r-G = N/A$	N/A		
Clogging Factor for a Single Unit Curb Opening (typical min. value = 0.1)	$C_r-C = 0.10$	0.10		
Street Hydraulics: OK - $Q <$ maximum allowable from sheet 'Q-Allow'				
Total Inlet Interception Capacity	$Q = 3.00$	7.28	cfs	
Total Inlet Carry-Over Flow (flow bypassing inlet)	$Q_b = 0.0$	4.1	cfs	
Capture Percentage = $Q_i/Q_o =$	$C\% = 100$	64	%	

**DESIGN PEAK FLOW FOR ONE-HALF OF STREET
OR GRASS-LINED CHANNEL BY THE RATIONAL METHOD**

Project: COMPARK SOUTH
Inlet ID: INLET 2-1

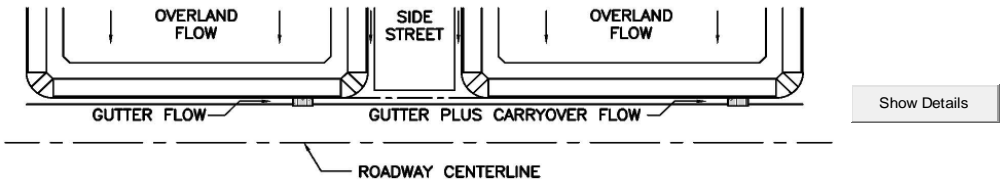

Design Flow: ONLY if already determined through other methods: (local peak flow for 1/2 of street OR grass-lined channel):		<table border="1" style="display: inline-table; border-collapse: collapse;"> <tr> <td style="padding: 2px;">Minor Storm</td> <td style="padding: 2px;">Major Storm</td> </tr> <tr> <td align="center" style="padding: 2px;">4.0</td> <td align="center" style="padding: 2px;">14.7</td> </tr> <tr> <td align="center" colspan="2" style="padding: 2px;">cfs</td> </tr> </table>	Minor Storm	Major Storm	4.0	14.7	cfs		<--- FILL IN THIS SECTION OR... FILL IN THE SECTIONS BELOW. <---
Minor Storm	Major Storm								
4.0	14.7								
cfs									
* If you enter values in Row 14, skip the rest of this sheet and proceed to sheet Q-Allow or Area Inlet.									
Geographic Information: (Enter data in the blue cells):									
Site Type: <input type="radio"/> Site is Urban <input type="radio"/> Site is Non-Urban	Flows Developed For: <input type="radio"/> Street Inlets <input type="radio"/> Area Inlets in a Median	Subcatchment Area = <input type="text"/> Acres Percent Imperviousness = <input type="text"/> % NRCS Soil Type = <input type="text"/> A, B, C, or D							
		<table border="1" style="display: inline-table; border-collapse: collapse;"> <tr> <td style="padding: 2px;">Slope (ft/ft)</td> <td style="padding: 2px;">Length (ft)</td> </tr> <tr> <td style="padding: 2px;">Overland Flow =</td> <td style="padding: 2px;"></td> </tr> <tr> <td style="padding: 2px;">Channel Flow =</td> <td style="padding: 2px;"></td> </tr> </table>	Slope (ft/ft)	Length (ft)	Overland Flow =		Channel Flow =		
Slope (ft/ft)	Length (ft)								
Overland Flow =									
Channel Flow =									
Rainfall Information: Intensity I (inch/hr) = $C_1 * P_1 / (C_2 + T_c)^{C_3}$									
	Design Storm Return Period, T_r = <input type="text"/> years Return Period One-Hour Precipitation, P_1 = <input type="text"/> inches C_1 = <input type="text"/> C_2 = <input type="text"/> C_3 = <input type="text"/> User-Defined Storm Runoff Coefficient (leave this blank to accept a calculated value), C = <input type="text"/> User-Defined 5-yr. Runoff Coefficient (leave this blank to accept a calculated value), C_5 = <input type="text"/>	<table border="1" style="display: inline-table; border-collapse: collapse;"> <tr> <td style="padding: 2px;">Minor Storm</td> <td style="padding: 2px;">Major Storm</td> </tr> <tr> <td style="padding: 2px;">0.0</td> <td style="padding: 2px;">0.0</td> </tr> <tr> <td align="center" colspan="2" style="padding: 2px;">cfs</td> </tr> </table>	Minor Storm	Major Storm	0.0	0.0	cfs		
Minor Storm	Major Storm								
0.0	0.0								
cfs									
		Bypass (Carry-Over) Flow from upstream Subcatchments, Q_b = <input type="text"/> cfs							
		Total Design Peak Flow, Q = <input type="text"/> 4.0 <input type="text"/> 14.7 cfs							

ALLOWABLE CAPACITY FOR ONE-HALF OF STREET (Minor & Major Storm)

(Based on Regulated Criteria for Maximum Allowable Flow Depth and Spread)

Project: COMPARK SOUTH

Inlet ID: INLET 2-1

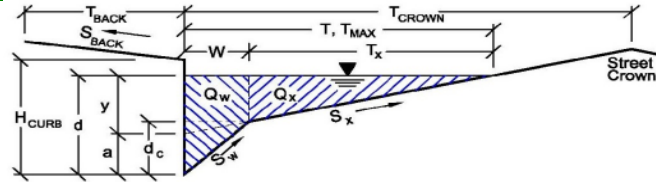

Gutter Geometry (Enter data in the blue cells)

Maximum Allowable Width for Spread Behind Curb

$T_{BACK} = 17.5$ ft

Side Slope Behind Curb (leave blank for no conveyance credit behind curb)

$S_{BACK} = 0.020$ ft/ft

Manning's Roughness Behind Curb (typically between 0.012 and 0.020)

$n_{BACK} = 0.020$

Height of Curb at Gutter Flow Line

$H_{CURB} = 6.00$ inches

Distance from Curb Face to Street Crown

$T_{CROWN} = 37.0$ ft

Gutter Width

$W = 2.00$ ft

Street Transverse Slope

$S_x = 0.020$ ft/ft

Gutter Cross Slope (typically 2 inches over 24 inches or 0.083 ft/ft)

$S_w = 0.083$ ft/ft

Street Longitudinal Slope - Enter 0 for sump condition

$S_o = 0.019$ ft/ft

Manning's Roughness for Street Section (typically between 0.012 and 0.020)

$n_{STREET} = 0.013$

Max. Allowable Spread for Minor & Major Storm

	Minor Storm	Major Storm	
$T_{MAX} =$	20.0	37.0	ft

Max. Allowable Depth at Gutter Flowline for Minor & Major Storm

$d_{MAX} =$	6.0	12.0	inches
-------------	-----	------	--------

Allow Flow Depth at Street Crown (leave blank for no)

<input type="checkbox"/>	<input checked="" type="checkbox"/>	check = yes
--------------------------	-------------------------------------	-------------

MINOR STORM Allowable Capacity is based on Depth Criterion

MAJOR STORM Allowable Capacity is based on Depth Criterion

	Minor Storm	Major Storm	
$Q_{allow} =$	23.4	207.0	cfs

Minor storm max. allowable capacity GOOD - greater than flow given on sheet 'Q-Peak'

Major storm max. allowable capacity GOOD - greater than flow given on sheet 'Q-Peak'

INLET ON A CONTINUOUS GRADE

Project: COMPARK SOUTH
 Inlet ID: INLET 2-1

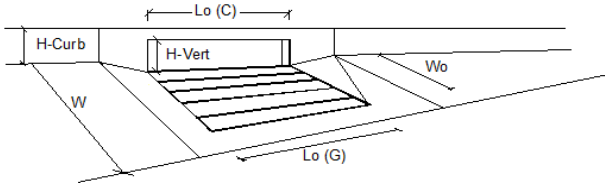

Design Information (Input)	MINOR		MAJOR		
Type of Inlet	Type = CDOT Type R Curb Opening				
Local Depression (additional to continuous gutter depression 'a' from 'Q-Allow')	a _{LOCAL} =	3.0	3.0		inches
Total Number of Units in the Inlet (Grate or Curb Opening)	No =	2	2		
Length of a Single Unit Inlet (Grate or Curb Opening)	L _G =	5.00	5.00		ft
Width of a Unit Grate (cannot be greater than W from Q-Allow)	W _G =	N/A	N/A		ft
Clogging Factor for a Single Unit Grate (typical min. value = 0.5)	C _{r-G} =	N/A	N/A		
Clogging Factor for a Single Unit Curb Opening (typical min. value = 0.1)	C _{r-C} =	0.10	0.10		
Street Hydraulics: OK - Q < maximum allowable from sheet 'Q-Allow'					
Total Inlet Interception Capacity	Q =	3.90	8.29		cfs
Total Inlet Carry-Over Flow (flow bypassing inlet)	Q _b =	0.1	6.4		cfs
Capture Percentage = Q _i /Q _o =	C% =	98	56		%

**DESIGN PEAK FLOW FOR ONE-HALF OF STREET
OR GRASS-LINED CHANNEL BY THE RATIONAL METHOD**

Project: COMPARK SOUTH
Inlet ID: INLET 2-2

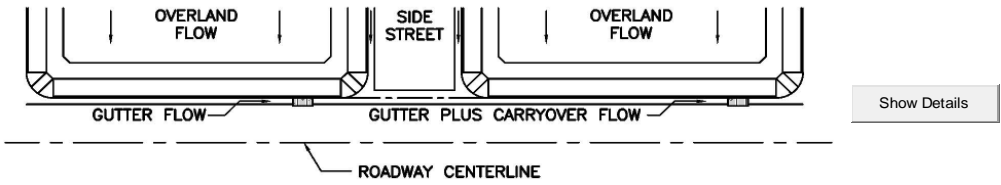

Design Flow: ONLY if already determined through other methods: (local peak flow for 1/2 of street OR grass-lined channel):		<table border="1" style="display: inline-table;"> <tr> <td>Minor Storm</td> <td>Major Storm</td> </tr> <tr> <td align="center">4.2</td> <td align="center">22.6</td> </tr> </table> cfs	Minor Storm	Major Storm	4.2	22.6	<--- FILL IN THIS SECTION OR... FILL IN THE SECTIONS BELOW. <---
Minor Storm	Major Storm						
4.2	22.6						
* If you enter values in Row 14, skip the rest of this sheet and proceed to sheet Q-Allow or Area Inlet.							
Geographic Information: (Enter data in the blue cells):							
Site Type: <input type="radio"/> Site is Urban <input type="radio"/> Site is Non-Urban	Flows Developed For: <input type="radio"/> Street Inlets <input type="radio"/> Area Inlets in a Median	Subcatchment Area = <input type="text"/> Acres Percent Imperviousness = <input type="text"/> % NRCS Soil Type = <input type="text"/> A, B, C, or D					
		Slope (ft/ft) Length (ft) Overland Flow = <input type="text"/> <input type="text"/> Channel Flow = <input type="text"/> <input type="text"/>					
Rainfall Information: Intensity I (inch/hr) = $C_1 * P_1 / (C_2 + T_c)^{C_3}$		<table border="1" style="display: inline-table;"> <tr> <td>Minor Storm</td> <td>Major Storm</td> </tr> <tr> <td></td> <td></td> </tr> </table> years	Minor Storm	Major Storm			
Minor Storm	Major Storm						
		Design Storm Return Period, T_r = <input type="text"/>					
		Return Period One-Hour Precipitation, P_1 = <input type="text"/>	inches				
		C_1 = <input type="text"/>					
		C_2 = <input type="text"/>					
		C_3 = <input type="text"/>					
User-Defined Storm Runoff Coefficient (leave this blank to accept a calculated value), C = <input type="text"/>							
User-Defined 5-yr. Runoff Coefficient (leave this blank to accept a calculated value), C_5 = <input type="text"/>							
		Bypass (Carry-Over) Flow from upstream Subcatchments, Q_b = <input type="text"/>	0.1 6.4 cfs				
		Total Design Peak Flow, Q = <input type="text"/>	4.3 29.0 cfs				

ALLOWABLE CAPACITY FOR ONE-HALF OF STREET (Minor & Major Storm)

(Based on Regulated Criteria for Maximum Allowable Flow Depth and Spread)

Project:
Inlet ID:

COMPARK SOUTH
INLET 2-2

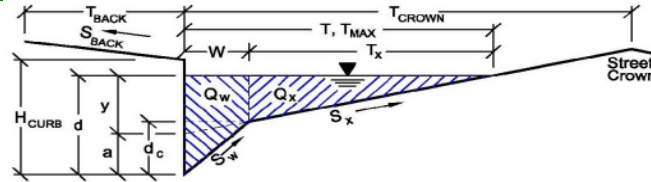

Gutter Geometry (Enter data in the blue cells)					
Maximum Allowable Width for Spread Behind Curb	$T_{BACK} = 17.5$ ft				
Side Slope Behind Curb (leave blank for no conveyance credit behind curb)	$S_{BACK} = 0.020$ ft/ft				
Manning's Roughness Behind Curb (typically between 0.012 and 0.020)	$n_{BACK} = 0.020$				
Height of Curb at Gutter Flow Line	$H_{CURB} = 6.00$ inches				
Distance from Curb Face to Street Crown	$T_{CROWN} = 37.0$ ft				
Gutter Width	$W = 2.00$ ft				
Street Transverse Slope	$S_x = 0.020$ ft/ft				
Gutter Cross Slope (typically 2 inches over 24 inches or 0.083 ft/ft)	$S_w = 0.083$ ft/ft				
Street Longitudinal Slope - Enter 0 for sump condition	$S_o = 0.000$ ft/ft				
Manning's Roughness for Street Section (typically between 0.012 and 0.020)	$n_{STREET} = 0.013$				
Max. Allowable Spread for Minor & Major Storm	<table border="1" style="display: inline-table; border-collapse: collapse;"> <tr> <td style="text-align: center;">Minor Storm</td> <td style="text-align: center;">Major Storm</td> </tr> <tr> <td style="text-align: center;">$T_{MAX} = 20.0$</td> <td style="text-align: center;">$T_{MAX} = 37.0$</td> </tr> </table>	Minor Storm	Major Storm	$T_{MAX} = 20.0$	$T_{MAX} = 37.0$
Minor Storm	Major Storm				
$T_{MAX} = 20.0$	$T_{MAX} = 37.0$				
Max. Allowable Depth at Gutter Flowline for Minor & Major Storm	<table border="1" style="display: inline-table; border-collapse: collapse;"> <tr> <td style="text-align: center;">Minor Storm</td> <td style="text-align: center;">Major Storm</td> </tr> <tr> <td style="text-align: center;">$d_{MAX} = 6.0$</td> <td style="text-align: center;">$d_{MAX} = 12.0$</td> </tr> </table>	Minor Storm	Major Storm	$d_{MAX} = 6.0$	$d_{MAX} = 12.0$
Minor Storm	Major Storm				
$d_{MAX} = 6.0$	$d_{MAX} = 12.0$				
Allow Flow Depth at Street Crown (leave blank for no)	<table style="display: inline-table; border-collapse: collapse;"> <tr> <td style="text-align: center;"><input type="checkbox"/></td> <td style="text-align: center;"><input checked="" type="checkbox"/></td> <td style="padding-left: 10px;">check = yes</td> </tr> </table>	<input type="checkbox"/>	<input checked="" type="checkbox"/>	check = yes	
<input type="checkbox"/>	<input checked="" type="checkbox"/>	check = yes			
MINOR STORM Allowable Capacity is based on Depth Criterion					
MAJOR STORM Allowable Capacity is based on Depth Criterion					
Minor storm max. allowable capacity GOOD - greater than flow given on sheet 'Q-Peak'	$Q_{allow} =$ <table border="1" style="display: inline-table; border-collapse: collapse;"><tr><td style="text-align: center;">SUMP</td></tr></table> cfs	SUMP			
SUMP					
Major storm max. allowable capacity GOOD - greater than flow given on sheet 'Q-Peak'	<table border="1" style="display: inline-table; border-collapse: collapse;"><tr><td style="text-align: center;">SUMP</td></tr></table> cfs	SUMP			
SUMP					

INLET IN A SUMP OR SAG LOCATION

Project = **COMPARK SOUTH**
 Inlet ID = **INLET 2-2**

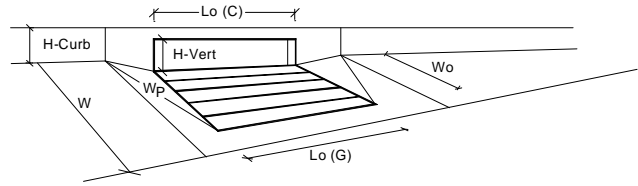

Design Information (Input)	MINOR		MAJOR	
	Type of Inlet	CDOT Type R Curb Opening		
Local Depression (additional to continuous gutter depression 'a' from 'Q-Allow')	$a_{local} =$	3.00	3.00	inches
Number of Unit Inlets (Grate or Curb Opening)	$N_o =$	3	3	
Water Depth at Flowline (outside of local depression)	Ponding Depth =	6.0	10.4	inches
Grate Information	<input type="checkbox"/> Override Depths			
Length of a Unit Grate	$L_o (G) =$	N/A	N/A	feet
Width of a Unit Grate	$W_o =$	N/A	N/A	feet
Area Opening Ratio for a Grate (typical values 0.15-0.90)	$A_{ratio} =$	N/A	N/A	
Clogging Factor for a Single Grate (typical value 0.50 - 0.70)	$C_r (G) =$	N/A	N/A	
Grate Weir Coefficient (typical value 2.15 - 3.60)	$C_w (G) =$	N/A	N/A	
Grate Orifice Coefficient (typical value 0.60 - 0.80)	$C_o (G) =$	N/A	N/A	
Curb Opening Information				
Length of a Unit Curb Opening	$L_o (C) =$	5.00	5.00	feet
Height of Vertical Curb Opening in Inches	$H_{vert} =$	6.00	6.00	inches
Height of Curb Orifice Throat in Inches	$H_{throat} =$	6.00	6.00	inches
Angle of Throat (see USDCM Figure ST-5)	Theta =	63.40	63.40	degrees
Side Width for Depression Pan (typically the gutter width of 2 feet)	$W_p =$	2.00	2.00	feet
Clogging Factor for a Single Curb Opening (typical value 0.10)	$C_r (C) =$	0.10	0.10	
Curb Opening Weir Coefficient (typical value 2.3-3.7)	$C_w (C) =$	3.60	3.60	
Curb Opening Orifice Coefficient (typical value 0.60 - 0.70)	$C_o (C) =$	0.67	0.67	
Total Inlet Interception Capacity (assumes clogged condition)				
Inlet Capacity IS GOOD for Minor and Major Storms (>Q PEAK)	$Q_a =$	13.5	36.4	cfs
	$Q_{PEAK REQUIRED} =$	4.3	29.0	cfs

**DESIGN PEAK FLOW FOR ONE-HALF OF STREET
OR GRASS-LINED CHANNEL BY THE RATIONAL METHOD**

Project: COMPARK SOUTH
Inlet ID: INLET 2-3

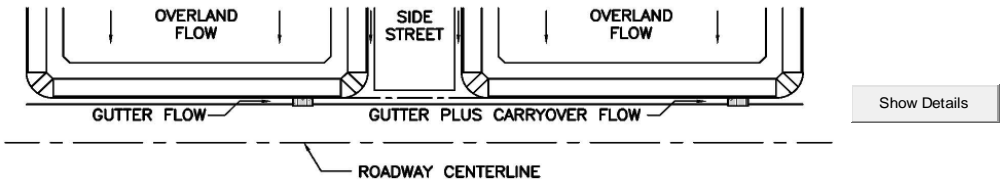

<p>Design Flow: ONLY if already determined through other methods: (local peak flow for 1/2 of street OR grass-lined channel):</p> <p>*Q_{known} = <table border="1" style="display: inline-table;"><tr><td style="width: 50px; text-align: center;">4.5</td><td style="width: 50px; text-align: center;">9.9</td></tr></table> cfs</p> <p><i>* If you enter values in Row 14, skip the rest of this sheet and proceed to sheet Q-Allow or Area Inlet.</i></p>		4.5	9.9	<p><--- FILL IN THIS SECTION OR... FILL IN THE SECTIONS BELOW. <---</p>		
4.5	9.9					
<p>Geographic Information: (Enter data in the blue cells):</p> <div style="display: flex; justify-content: space-between;"> <div style="width: 30%;"> <p>Site Type:</p> <p><input type="radio"/> Site is Urban</p> <p><input type="radio"/> Site is Non-Urban</p> </div> <div style="width: 30%;"> <p>Flows Developed For:</p> <p><input type="radio"/> Street Inlets</p> <p><input type="radio"/> Area Inlets in a Median</p> </div> <div style="width: 30%;"> <p>Subcatchment Area = <input type="text"/> Acres</p> <p>Percent Imperviousness = <input type="text"/> %</p> <p>NRCS Soil Type = <input type="text"/> A, B, C, or D</p> </div> </div> <div style="display: flex; justify-content: space-between; margin-top: 10px;"> <div style="width: 45%;"> <p>Slope (ft/ft) Length (ft)</p> <p>Overland Flow = <input type="text"/> <input type="text"/></p> <p>Channel Flow = <input type="text"/> <input type="text"/></p> </div> </div>						
<p>Rainfall Information: Intensity I (inch/hr) = $C_1 * P_1 / (C_2 + T_c)^{C_3}$</p> <p>Design Storm Return Period, T_r = <input type="text"/> years</p> <p>Return Period One-Hour Precipitation, P₁ = <input type="text"/> inches</p> <p>C₁ = <input type="text"/></p> <p>C₂ = <input type="text"/></p> <p>C₃ = <input type="text"/></p> <p>User-Defined Storm Runoff Coefficient (leave this blank to accept a calculated value), C = <input type="text"/></p> <p>User-Defined 5-yr. Runoff Coefficient (leave this blank to accept a calculated value), C₅ = <input type="text"/></p> <p>Bypass (Carry-Over) Flow from upstream Subcatchments, Q_b = <table border="1" style="display: inline-table;"><tr><td style="width: 50px; text-align: center;">0.0</td><td style="width: 50px; text-align: center;">0.0</td></tr></table> cfs</p> <p style="text-align: right;">Total Design Peak Flow, Q = <table border="1" style="display: inline-table;"><tr><td style="width: 50px; text-align: center;">4.5</td><td style="width: 50px; text-align: center;">9.9</td></tr></table> cfs</p>		0.0	0.0	4.5	9.9	
0.0	0.0					
4.5	9.9					

ALLOWABLE CAPACITY FOR ONE-HALF OF STREET (Minor & Major Storm)

(Based on Regulated Criteria for Maximum Allowable Flow Depth and Spread)

Project:
Inlet ID:

COMPARK SOUTH
INLET 2-3

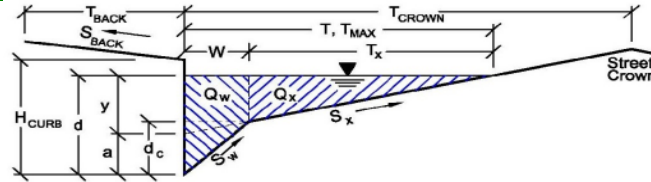

Gutter Geometry (Enter data in the blue cells)

Maximum Allowable Width for Spread Behind Curb

$T_{BACK} = 17.5$ ft

Side Slope Behind Curb (leave blank for no conveyance credit behind curb)

$S_{BACK} = 0.020$ ft/ft

Manning's Roughness Behind Curb (typically between 0.012 and 0.020)

$n_{BACK} = 0.013$

Height of Curb at Gutter Flow Line

$H_{CURB} = 6.00$ inches

Distance from Curb Face to Street Crown

$T_{CROWN} = 37.0$ ft

Gutter Width

$W = 2.00$ ft

Street Transverse Slope

$S_x = 0.020$ ft/ft

Gutter Cross Slope (typically 2 inches over 24 inches or 0.083 ft/ft)

$S_w = 0.083$ ft/ft

Street Longitudinal Slope - Enter 0 for sump condition

$S_o = 0.015$ ft/ft

Manning's Roughness for Street Section (typically between 0.012 and 0.020)

$n_{STREET} = 0.013$

Max. Allowable Spread for Minor & Major Storm

	Minor Storm	Major Storm	
T_{MAX}	20.0	37.0	ft

Max. Allowable Depth at Gutter Flowline for Minor & Major Storm

	Minor Storm	Major Storm	
d_{MAX}	6.0	12.0	inches

Allow Flow Depth at Street Crown (leave blank for no)

check = yes

MINOR STORM Allowable Capacity is based on Depth Criterion

MAJOR STORM Allowable Capacity is based on Depth Criterion

	Minor Storm	Major Storm	
Q_{allow}	20.8	225.6	cfs

Minor storm max. allowable capacity **GOOD** - greater than flow given on sheet 'Q-Peak'

Major storm max. allowable capacity **GOOD** - greater than flow given on sheet 'Q-Peak'

INLET ON A CONTINUOUS GRADE

Project: COMPARK SOUTH
 Inlet ID: INLET 2-3

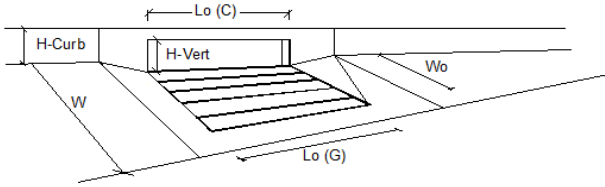

Design Information (Input)	MINOR		MAJOR	
	Type of Inlet	Type = CDOT Type R Curb Opening		
Local Depression (additional to continuous gutter depression 'a' from 'Q-Allow')	$a_{LOCAL} = 3.0$	3.0	3.0	inches
Total Number of Units in the Inlet (Grate or Curb Opening)	$N_o = 3$	3	3	
Length of a Single Unit Inlet (Grate or Curb Opening)	$L_o = 5.00$	5.00	5.00	ft
Width of a Unit Grate (cannot be greater than W from Q-Allow)	$W_o = N/A$	N/A	N/A	ft
Clogging Factor for a Single Unit Grate (typical min. value = 0.5)	$C_r-G = N/A$	N/A	N/A	
Clogging Factor for a Single Unit Curb Opening (typical min. value = 0.1)	$C_r-C = 0.10$	0.10	0.10	
Street Hydraulics: OK - $Q <$ maximum allowable from sheet 'Q-Allow'				
Total Inlet Interception Capacity	$Q = 4.50$	4.50	8.95	cfs
Total Inlet Carry-Over Flow (flow bypassing inlet)	$Q_b = 0.0$	0.0	1.0	cfs
Capture Percentage = $Q_i/Q_o =$	$C\% = 100$	100	90	%

**DESIGN PEAK FLOW FOR ONE-HALF OF STREET
OR GRASS-LINED CHANNEL BY THE RATIONAL METHOD**

Project: COMPARK SOUTH
 Inlet ID: INLET 2-4

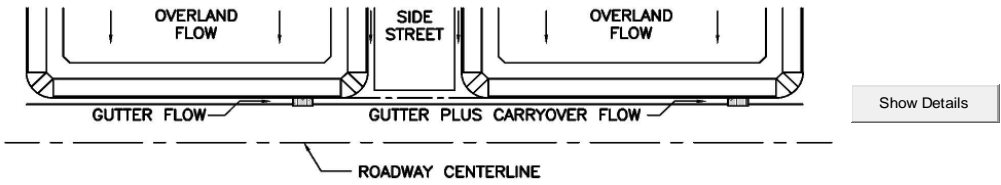

Design Flow: ONLY if already determined through other methods: (local peak flow for 1/2 of street OR grass-lined channel):		Minor Storm Major Storm *Q _{known} = <input type="text" value="2.6"/> <input type="text" value="7.5"/> cfs	<--- FILL IN THIS SECTION OR... FILL IN THE SECTIONS BELOW. <---
Geographic Information: (Enter data in the blue cells):		Subcatchment Area = <input type="text"/> Acres Percent Imperviousness = <input type="text"/> % NRCS Soil Type = <input type="text"/> A, B, C, or D	
Site Type: <input type="radio"/> Site is Urban <input type="radio"/> Site is Non-Urban	Flows Developed For: <input type="radio"/> Street Inlets <input type="radio"/> Area Inlets in a Median	Slope (ft/ft) Length (ft) Overland Flow = <input type="text"/> <input type="text"/> Channel Flow = <input type="text"/> <input type="text"/>	
Rainfall Information: Intensity I (inch/hr) = $C_1 * P_1 / (C_2 + I_c)^{C_3}$		Minor Storm Major Storm	
Design Storm Return Period, T _r = <input type="text"/> years Return Period One-Hour Precipitation, P ₁ = <input type="text"/> inches C ₁ = <input type="text"/> C ₂ = <input type="text"/> C ₃ = <input type="text"/> User-Defined Storm Runoff Coefficient (leave this blank to accept a calculated value), C = <input type="text"/> User-Defined 5-yr. Runoff Coefficient (leave this blank to accept a calculated value), C ₅ = <input type="text"/>		Bypass (Carry-Over) Flow from upstream Subcatchments, Q _b = <input type="text" value="0.0"/> <input type="text" value="1.0"/> cfs	
Total Design Peak Flow, Q = <input type="text" value="2.6"/> <input type="text" value="8.5"/> cfs			

ALLOWABLE CAPACITY FOR ONE-HALF OF STREET (Minor & Major Storm)

(Based on Regulated Criteria for Maximum Allowable Flow Depth and Spread)

Project:
Inlet ID:

COMPARK SOUTH
INLET 2-4

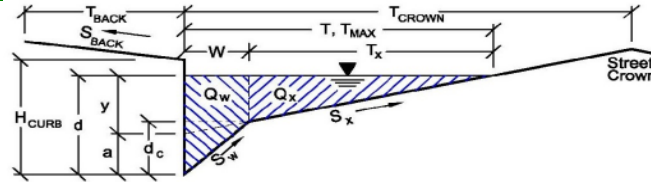

Gutter Geometry (Enter data in the blue cells)

Maximum Allowable Width for Spread Behind Curb
Side Slope Behind Curb (leave blank for no conveyance credit behind curb)
Manning's Roughness Behind Curb (typically between 0.012 and 0.020)

$T_{BACK} = 5.0$ ft
 $S_{BACK} = 0.020$ ft/ft
 $n_{BACK} = 0.013$

Height of Curb at Gutter Flow Line
Distance from Curb Face to Street Crown
Gutter Width
Street Transverse Slope
Gutter Cross Slope (typically 2 inches over 24 inches or 0.083 ft/ft)
Street Longitudinal Slope - Enter 0 for sump condition
Manning's Roughness for Street Section (typically between 0.012 and 0.020)

$H_{CURB} = 6.00$ inches
 $T_{CROWN} = 37.0$ ft
 $W = 2.00$ ft
 $S_x = 0.020$ ft/ft
 $S_w = 0.083$ ft/ft
 $S_o = 0.015$ ft/ft
 $n_{STREET} = 0.013$

Max. Allowable Spread for Minor & Major Storm
Max. Allowable Depth at Gutter Flowline for Minor & Major Storm
Allow Flow Depth at Street Crown (leave blank for no)

	Minor Storm	Major Storm	
T_{MAX}	20.0	37.0	ft
d_{MAX}	6.0	12.0	inches
	<input type="checkbox"/>	<input checked="" type="checkbox"/>	check = yes

MINOR STORM Allowable Capacity is based on Depth Criterion
MAJOR STORM Allowable Capacity is based on Depth Criterion

$Q_{allow} =$

20.8	204.4
------	-------

 cfs

Minor storm max. allowable capacity GOOD - greater than flow given on sheet 'Q-Peak'
Major storm max. allowable capacity GOOD - greater than flow given on sheet 'Q-Peak'

INLET ON A CONTINUOUS GRADE

Project: COMPARK SOUTH
 Inlet ID: INLET 2-4

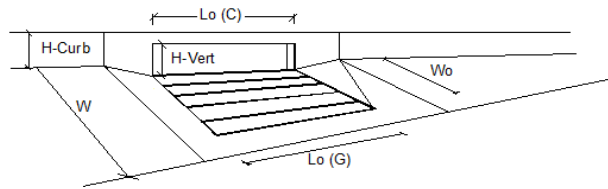

Design Information (Input)	MINOR		MAJOR		
	MINOR	MAJOR	MINOR	MAJOR	
Type of Inlet	Type = CDOT Type R Curb Opening				
Local Depression (additional to continuous gutter depression 'a' from 'Q-Allow')	$a_{LOCAL} = 3.0$	3.0	3.0	3.0	inches
Total Number of Units in the Inlet (Grate or Curb Opening)	$N_o = 3$	3	3	3	
Length of a Single Unit Inlet (Grate or Curb Opening)	$L_o = 5.00$	5.00	5.00	5.00	ft
Width of a Unit Grate (cannot be greater than W from Q-Allow)	$W_o = N/A$	N/A	N/A	N/A	ft
Clogging Factor for a Single Unit Grate (typical min. value = 0.5)	$C_r-G = N/A$	N/A	N/A	N/A	
Clogging Factor for a Single Unit Curb Opening (typical min. value = 0.1)	$C_r-C = 0.10$	0.10	0.10	0.10	
Street Hydraulics: OK - $Q <$ maximum allowable from sheet 'Q-Allow'					
Total Inlet Interception Capacity	$Q = 2.60$	8.05	2.60	8.05	cfs
Total Inlet Carry-Over Flow (flow bypassing inlet)	$Q_b = 0.0$	0.5	0.0	0.5	cfs
Capture Percentage = $Q_i/Q_o =$	$C\% = 100$	95	100	95	%

**DESIGN PEAK FLOW FOR ONE-HALF OF STREET
OR GRASS-LINED CHANNEL BY THE RATIONAL METHOD**

Project: COMPARK SOUTH
 Inlet ID: INLET 2-5

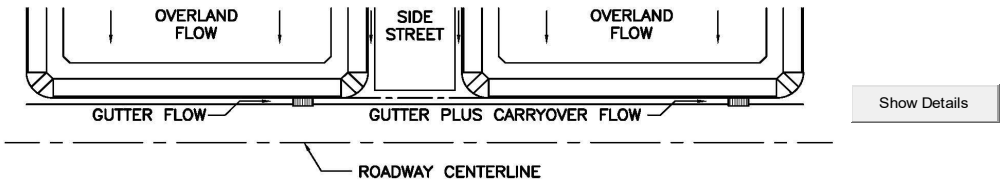

<p>Design Flow: ONLY if already determined through other methods: (local peak flow for 1/2 of street OR grass-lined channel):</p>		<table border="1" style="display: inline-table; border-collapse: collapse;"> <tr> <td style="padding: 2px;">Minor Storm</td> <td style="padding: 2px;">Major Storm</td> </tr> <tr> <td style="text-align: center; padding: 2px;">7.9</td> <td style="text-align: center; padding: 2px;">21.7</td> </tr> <tr> <td colspan="2" style="text-align: right; padding: 2px;">cfs</td> </tr> </table>	Minor Storm	Major Storm	7.9	21.7	cfs		<p style="color: red; font-size: small;"><--- FILL IN THIS SECTION OR... FILL IN THE SECTIONS BELOW. <---</p>																														
Minor Storm	Major Storm																																						
7.9	21.7																																						
cfs																																							
<p>* If you enter values in Row 14, skip the rest of this sheet and proceed to sheet Q-Allow or Area Inlet.</p>																																							
<p>Geographic Information: (Enter data in the blue cells):</p>																																							
<p>Site Type:</p> <p><input type="radio"/> Site is Urban</p> <p><input type="radio"/> Site is Non-Urban</p>	<p>Flows Developed For:</p> <p><input type="radio"/> Street Inlets</p> <p><input type="radio"/> Area Inlets in a Median</p>	<p>Subcatchment Area = <input type="text"/> Acres</p> <p>Percent Imperviousness = <input type="text"/> %</p> <p>NRCS Soil Type = <input type="text"/> A, B, C, or D</p>																																					
		<table border="1" style="display: inline-table; border-collapse: collapse;"> <tr> <td style="padding: 2px;">Slope (ft/ft)</td> <td style="padding: 2px;">Length (ft)</td> </tr> <tr> <td style="padding: 2px;">Overland Flow =</td> <td style="padding: 2px;"><input type="text"/></td> </tr> <tr> <td style="padding: 2px;">Channel Flow =</td> <td style="padding: 2px;"><input type="text"/></td> </tr> </table>	Slope (ft/ft)	Length (ft)	Overland Flow =	<input type="text"/>	Channel Flow =	<input type="text"/>																															
Slope (ft/ft)	Length (ft)																																						
Overland Flow =	<input type="text"/>																																						
Channel Flow =	<input type="text"/>																																						
<p>Rainfall Information: Intensity I (inch/hr) = $C_1 * P_1 / (C_2 + T_c)^{C_3}$</p>																																							
		<table border="1" style="display: inline-table; border-collapse: collapse;"> <tr> <td style="padding: 2px;">Design Storm Return Period, T_r =</td> <td style="padding: 2px;">Minor Storm</td> <td style="padding: 2px;">Major Storm</td> <td style="padding: 2px;">years</td> </tr> <tr> <td style="padding: 2px;">Return Period One-Hour Precipitation, P_1 =</td> <td style="padding: 2px;"><input type="text"/></td> <td style="padding: 2px;"><input type="text"/></td> <td style="padding: 2px;">inches</td> </tr> <tr> <td style="padding: 2px;">C_1 =</td> <td style="padding: 2px;"><input type="text"/></td> <td style="padding: 2px;"><input type="text"/></td> <td></td> </tr> <tr> <td style="padding: 2px;">C_2 =</td> <td style="padding: 2px;"><input type="text"/></td> <td style="padding: 2px;"><input type="text"/></td> <td></td> </tr> <tr> <td style="padding: 2px;">C_3 =</td> <td style="padding: 2px;"><input type="text"/></td> <td style="padding: 2px;"><input type="text"/></td> <td></td> </tr> <tr> <td style="padding: 2px;">User-Defined Storm Runoff Coefficient (leave this blank to accept a calculated value), C =</td> <td style="padding: 2px;"><input type="text"/></td> <td style="padding: 2px;"><input type="text"/></td> <td></td> </tr> <tr> <td style="padding: 2px;">User-Defined 5-yr. Runoff Coefficient (leave this blank to accept a calculated value), C_5 =</td> <td style="padding: 2px;"><input type="text"/></td> <td style="padding: 2px;"><input type="text"/></td> <td></td> </tr> <tr> <td style="padding: 2px;">Bypass (Carry-Over) Flow from upstream Subcatchments, Q_b =</td> <td style="text-align: center; padding: 2px;">0.0</td> <td style="text-align: center; padding: 2px;">1.9</td> <td style="padding: 2px;">cfs</td> </tr> <tr> <td style="padding: 2px;">Total Design Peak Flow, Q =</td> <td style="text-align: center; padding: 2px;">7.9</td> <td style="text-align: center; padding: 2px;">23.6</td> <td style="padding: 2px;">cfs</td> </tr> </table>	Design Storm Return Period, T_r =	Minor Storm	Major Storm	years	Return Period One-Hour Precipitation, P_1 =	<input type="text"/>	<input type="text"/>	inches	C_1 =	<input type="text"/>	<input type="text"/>		C_2 =	<input type="text"/>	<input type="text"/>		C_3 =	<input type="text"/>	<input type="text"/>		User-Defined Storm Runoff Coefficient (leave this blank to accept a calculated value), C =	<input type="text"/>	<input type="text"/>		User-Defined 5-yr. Runoff Coefficient (leave this blank to accept a calculated value), C_5 =	<input type="text"/>	<input type="text"/>		Bypass (Carry-Over) Flow from upstream Subcatchments, Q_b =	0.0	1.9	cfs	Total Design Peak Flow, Q =	7.9	23.6	cfs	
Design Storm Return Period, T_r =	Minor Storm	Major Storm	years																																				
Return Period One-Hour Precipitation, P_1 =	<input type="text"/>	<input type="text"/>	inches																																				
C_1 =	<input type="text"/>	<input type="text"/>																																					
C_2 =	<input type="text"/>	<input type="text"/>																																					
C_3 =	<input type="text"/>	<input type="text"/>																																					
User-Defined Storm Runoff Coefficient (leave this blank to accept a calculated value), C =	<input type="text"/>	<input type="text"/>																																					
User-Defined 5-yr. Runoff Coefficient (leave this blank to accept a calculated value), C_5 =	<input type="text"/>	<input type="text"/>																																					
Bypass (Carry-Over) Flow from upstream Subcatchments, Q_b =	0.0	1.9	cfs																																				
Total Design Peak Flow, Q =	7.9	23.6	cfs																																				

ALLOWABLE CAPACITY FOR ONE-HALF OF STREET (Minor & Major Storm)

(Based on Regulated Criteria for Maximum Allowable Flow Depth and Spread)

Project: **COMPARK SOUTH**

Inlet ID: **INLET 2-5**

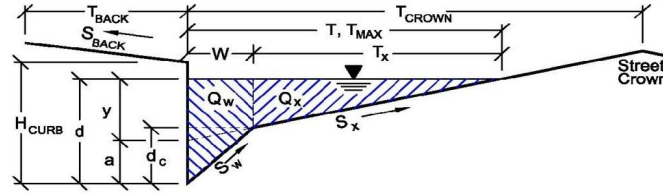

Gutter Geometry (Enter data in the blue cells)	
Maximum Allowable Width for Spread Behind Curb	$T_{BACK} = 0.0$ ft
Side Slope Behind Curb (leave blank for no conveyance credit behind curb)	$S_{BACK} = 0.020$ ft/ft
Manning's Roughness Behind Curb (typically between 0.012 and 0.020)	$n_{BACK} = 0.013$
Height of Curb at Gutter Flow Line	$H_{CURB} = 6.00$ inches
Distance from Curb Face to Street Crown	$T_{CROWN} = 37.0$ ft
Gutter Width	$W = 2.00$ ft
Street Transverse Slope	$S_x = 0.020$ ft/ft
Gutter Cross Slope (typically 2 inches over 24 inches or 0.083 ft/ft)	$S_w = 0.083$ ft/ft
Street Longitudinal Slope - Enter 0 for sump condition	$S_o = 0.000$ ft/ft
Manning's Roughness for Street Section (typically between 0.012 and 0.020)	$n_{STREET} = 0.016$
Max. Allowable Spread for Minor & Major Storm	$T_{MAX} = \begin{matrix} \text{Minor Storm} & \text{Major Storm} \\ 20.0 & 37.0 \end{matrix}$ ft
Max. Allowable Depth at Gutter Flowline for Minor & Major Storm	$d_{MAX} = \begin{matrix} \text{Minor Storm} & \text{Major Storm} \\ 6.0 & 10.2 \end{matrix}$ inches
Allow Flow Depth at Street Crown (leave blank for no)	<input type="checkbox"/> <input checked="" type="checkbox"/> check = yes
MINOR STORM Allowable Capacity is based on Depth Criterion	
MAJOR STORM Allowable Capacity is based on Depth Criterion	
Minor storm max. allowable capacity GOOD - greater than flow given on sheet 'Q-Peak'	
Major storm max. allowable capacity GOOD - greater than flow given on sheet 'Q-Peak'	
$Q_{allow} =$	$\begin{matrix} \text{Minor Storm} & \text{Major Storm} \\ \text{SUMP} & \text{SUMP} \end{matrix}$ cfs

INLET IN A SUMP OR SAG LOCATION

Project = **COMPARK SOUTH**
 Inlet ID = **INLET 2-5**

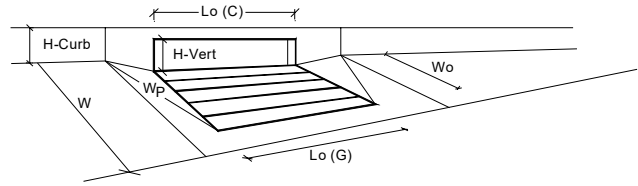

Design Information (Input)		MINOR		MAJOR	
Type of Inlet	Inlet Type =	CDOT Type R Curb Opening			
Local Depression (additional to continuous gutter depression 'a' from 'Q-Allow')	a_{local} =	3.00	3.00	inches	
Number of Unit Inlets (Grate or Curb Opening)	N_o =	2	2		
Water Depth at Flowline (outside of local depression)	Ponding Depth =	5.6	12.0	inches	<input checked="" type="checkbox"/> Override Depths
Grate Information		MINOR		MAJOR	
Length of a Unit Grate	$L_o (G)$ =	N/A	N/A	feet	
Width of a Unit Grate	W_o =	N/A	N/A	feet	
Area Opening Ratio for a Grate (typical values 0.15-0.90)	A_{ratio} =	N/A	N/A		
Clogging Factor for a Single Grate (typical value 0.50 - 0.70)	$C_r (G)$ =	N/A	N/A		
Grate Weir Coefficient (typical value 2.15 - 3.60)	$C_w (G)$ =	N/A	N/A		
Grate Orifice Coefficient (typical value 0.60 - 0.80)	$C_o (G)$ =	N/A	N/A		
Curb Opening Information		MINOR		MAJOR	
Length of a Unit Curb Opening	$L_o (C)$ =	5.00	5.00	feet	
Height of Vertical Curb Opening in Inches	H_{vert} =	6.00	6.00	inches	
Height of Curb Orifice Throat in Inches	H_{throat} =	6.00	6.00	inches	
Angle of Throat (see USDCM Figure ST-5)	Theta =	63.40	63.40	degrees	
Side Width for Depression Pan (typically the gutter width of 2 feet)	W_p =	2.00	2.00	feet	
Clogging Factor for a Single Curb Opening (typical value 0.10)	$C_r (C)$ =	0.10	0.10		
Curb Opening Weir Coefficient (typical value 2.3-3.7)	$C_w (C)$ =	3.60	3.60		
Curb Opening Orifice Coefficient (typical value 0.60 - 0.70)	$C_o (C)$ =	0.67	0.67		
Total Inlet Interception Capacity (assumes clogged condition)		MINOR		MAJOR	
	Q_a =	8.7	25.5	cfs	
	$Q_{PEAK REQUIRED}$ =	7.9	23.6	cfs	

Inlet Capacity IS GOOD for Minor and Major Storms (>Q PEAK)

**DESIGN PEAK FLOW FOR ONE-HALF OF STREET
OR GRASS-LINED CHANNEL BY THE RATIONAL METHOD**

Project: COMPARK SOUTH
 Inlet ID: INLET 2-6

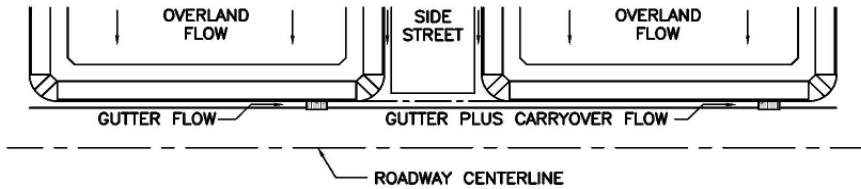

Show Details

Design Flow: ONLY if already determined through other methods: (local peak flow for 1/2 of street OR grass-lined channel):		<table border="1" style="display: inline-table; border-collapse: collapse;"> <tr> <td style="padding: 2px;">Minor Storm</td> <td style="padding: 2px;">Major Storm</td> </tr> <tr> <td style="text-align: center; padding: 2px;">3.0</td> <td style="text-align: center; padding: 2px;">8.1</td> </tr> <tr> <td colspan="2" style="text-align: right; padding: 2px;">cfs</td> </tr> </table>	Minor Storm	Major Storm	3.0	8.1	cfs		<--- FILL IN THIS SECTION OR... FILL IN THE SECTIONS BELOW. <---														
Minor Storm	Major Storm																						
3.0	8.1																						
cfs																							
* If you enter values in Row 14, skip the rest of this sheet and proceed to sheet Q-Allow or Area Inlet.																							
Geographic Information: (Enter data in the blue cells):																							
Site Type: <input type="radio"/> Site is Urban <input type="radio"/> Site is Non-Urban	Flows Developed For: <input type="radio"/> Street Inlets <input type="radio"/> Area Inlets in a Median	Subcatchment Area = <input type="text"/> Acres Percent Imperviousness = <input type="text"/> % NRCS Soil Type = <input type="text"/> A, B, C, or D																					
		<table border="1" style="display: inline-table; border-collapse: collapse;"> <tr> <td style="padding: 2px;">Slope (ft/ft)</td> <td style="padding: 2px;">Length (ft)</td> </tr> <tr> <td style="padding: 2px;">Overland Flow =</td> <td style="padding: 2px;"></td> </tr> <tr> <td style="padding: 2px;">Channel Flow =</td> <td style="padding: 2px;"></td> </tr> </table>	Slope (ft/ft)	Length (ft)	Overland Flow =		Channel Flow =																
Slope (ft/ft)	Length (ft)																						
Overland Flow =																							
Channel Flow =																							
Rainfall Information: Intensity I (inch/hr) = $C_1 * P_1 / (C_2 + T_c) ^{C_3}$																							
		<table border="1" style="display: inline-table; border-collapse: collapse;"> <tr> <td style="padding: 2px;">Minor Storm</td> <td style="padding: 2px;">Major Storm</td> </tr> <tr> <td style="padding: 2px;">Design Storm Return Period, T_r =</td> <td style="padding: 2px;"></td> </tr> <tr> <td style="padding: 2px;">Return Period One-Hour Precipitation, P_1 =</td> <td style="padding: 2px;"></td> </tr> <tr> <td style="padding: 2px;">C_1 =</td> <td style="padding: 2px;"></td> </tr> <tr> <td style="padding: 2px;">C_2 =</td> <td style="padding: 2px;"></td> </tr> <tr> <td style="padding: 2px;">C_3 =</td> <td style="padding: 2px;"></td> </tr> <tr> <td style="padding: 2px;">User-Defined Storm Runoff Coefficient (leave this blank to accept a calculated value), C =</td> <td style="padding: 2px;"></td> </tr> <tr> <td style="padding: 2px;">User-Defined 5-yr. Runoff Coefficient (leave this blank to accept a calculated value), C_5 =</td> <td style="padding: 2px;"></td> </tr> <tr> <td style="padding: 2px;">Bypass (Carry-Over) Flow from upstream Subcatchments, Q_b =</td> <td style="padding: 2px;">0.0 0.5</td> </tr> <tr> <td style="padding: 2px;">Total Design Peak Flow, Q =</td> <td style="padding: 2px;">3.0 8.6</td> </tr> </table>	Minor Storm	Major Storm	Design Storm Return Period, T_r =		Return Period One-Hour Precipitation, P_1 =		C_1 =		C_2 =		C_3 =		User-Defined Storm Runoff Coefficient (leave this blank to accept a calculated value), C =		User-Defined 5-yr. Runoff Coefficient (leave this blank to accept a calculated value), C_5 =		Bypass (Carry-Over) Flow from upstream Subcatchments, Q_b =	0.0 0.5	Total Design Peak Flow, Q =	3.0 8.6	years inches cfs
Minor Storm	Major Storm																						
Design Storm Return Period, T_r =																							
Return Period One-Hour Precipitation, P_1 =																							
C_1 =																							
C_2 =																							
C_3 =																							
User-Defined Storm Runoff Coefficient (leave this blank to accept a calculated value), C =																							
User-Defined 5-yr. Runoff Coefficient (leave this blank to accept a calculated value), C_5 =																							
Bypass (Carry-Over) Flow from upstream Subcatchments, Q_b =	0.0 0.5																						
Total Design Peak Flow, Q =	3.0 8.6																						

ALLOWABLE CAPACITY FOR ONE-HALF OF STREET (Minor & Major Storm)

(Based on Regulated Criteria for Maximum Allowable Flow Depth and Spread)

Project:

COMPARK SOUTH

Inlet ID:

INLET 2-6

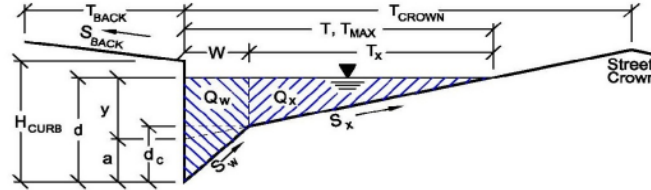

Gutter Geometry (Enter data in the blue cells)

Maximum Allowable Width for Spread Behind Curb
 Side Slope Behind Curb (leave blank for no conveyance credit behind curb)
 Manning's Roughness Behind Curb (typically between 0.012 and 0.020)
 Height of Curb at Gutter Flow Line
 Distance from Curb Face to Street Crown
 Gutter Width
 Street Transverse Slope
 Gutter Cross Slope (typically 2 inches over 24 inches or 0.083 ft/ft)
 Street Longitudinal Slope - Enter 0 for sump condition
 Manning's Roughness for Street Section (typically between 0.012 and 0.020)

T_{BACK}	=	5.0	ft
S_{BACK}	=	0.020	ft/ft
n_{BACK}	=	0.013	
H_{CURB}	=	6.00	inches
T_{CROWN}	=	37.0	ft
W	=	2.00	ft
S_x	=	0.020	ft/ft
S_w	=	0.083	ft/ft
S_D	=	0.005	ft/ft
n_{STREET}	=	0.013	

Max. Allowable Spread for Minor & Major Storm
 Max. Allowable Depth at Gutter Flowline for Minor & Major Storm
 Allow Flow Depth at Street Crown (leave blank for no)

	Minor Storm	Major Storm	
T_{MAX}	20.0	37.0	ft
d_{MAX}	6.0	12.0	inches
	<input type="checkbox"/>	<input checked="" type="checkbox"/>	check = yes

MINOR STORM Allowable Capacity is based on Depth Criterion
MAJOR STORM Allowable Capacity is based on Depth Criterion

	Minor Storm	Major Storm	
Q_{allow}	12.0	118.0	cfs

Minor storm max. allowable capacity GOOD - greater than flow given on sheet 'Q-Peak'
Major storm max. allowable capacity GOOD - greater than flow given on sheet 'Q-Peak'

INLET ON A CONTINUOUS GRADE

Project: COMPARK SOUTH
 Inlet ID: INLET 2-6

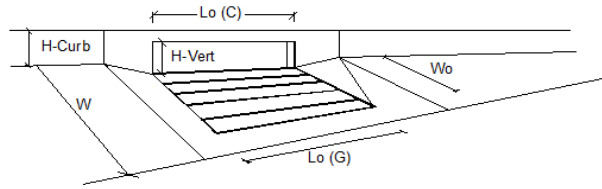

Design Information (Input)	MINOR		MAJOR	
	Type of Inlet	Type = CDOT Type R Curb Opening		
Local Depression (additional to continuous gutter depression 'a' from 'Q-Allow')	$a_{LOCAL} = 3.0$	3.0	3.0	inches
Total Number of Units in the Inlet (Grate or Curb Opening)	$N_o = 3$	3	3	
Length of a Single Unit Inlet (Grate or Curb Opening)	$L_o = 5.00$	5.00	5.00	ft
Width of a Unit Grate (cannot be greater than W from Q-Allow)	$W_o = N/A$	N/A	N/A	ft
Clogging Factor for a Single Unit Grate (typical min. value = 0.5)	$C_r-G = N/A$	N/A	N/A	
Clogging Factor for a Single Unit Curb Opening (typical min. value = 0.1)	$C_r-C = 0.10$	0.10	0.10	
Street Hydraulics: OK - $Q <$ maximum allowable from sheet 'Q-Allow'				
Total Inlet Interception Capacity	$Q = 3.00$	3.00	8.06	cfs
Total Inlet Carry-Over Flow (flow bypassing inlet)	$Q_b = 0.0$	0.0	0.5	cfs
Capture Percentage = $Q_c/Q_o =$	$C\% = 100$	100	94	%

**DESIGN PEAK FLOW FOR ONE-HALF OF STREET
OR GRASS-LINED CHANNEL BY THE RATIONAL METHOD**

Project: COMPARK SOUTH
Inlet ID: INLET 3-4

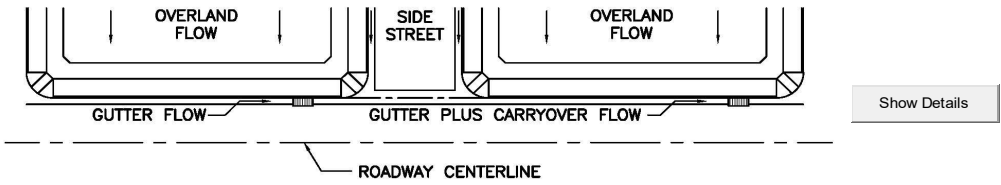

Design Flow: ONLY if already determined through other methods: (local peak flow for 1/2 of street OR grass-lined channel):		Minor Storm Major Storm * Q_{known} = <input type="text" value="3.9"/> <input type="text" value="10.7"/> cfs	<--- FILL IN THIS SECTION OR... FILL IN THE SECTIONS BELOW. <---
Geographic Information: (Enter data in the blue cells):		Subcatchment Area = <input type="text"/> Acres Percent Imperviousness = <input type="text"/> % NRCS Soil Type = <input type="text"/> A, B, C, or D	
Site Type: <input type="radio"/> Site is Urban <input type="radio"/> Site is Non-Urban	Flows Developed For: <input type="radio"/> Street Inlets <input type="radio"/> Area Inlets in a Median	Slope (ft/ft) Length (ft) Overland Flow = <input type="text"/> <input type="text"/> Channel Flow = <input type="text"/> <input type="text"/>	
Rainfall Information: Intensity I (inch/hr) = $C_1 * P_1 / (C_2 + T_c)^{C_3}$		Minor Storm Major Storm	
		Design Storm Return Period, T_r = <input type="text"/> years	
		Return Period One-Hour Precipitation, P_1 = <input type="text"/> inches	
		C_1 = <input type="text"/>	
		C_2 = <input type="text"/>	
		C_3 = <input type="text"/>	
User-Defined Storm Runoff Coefficient (leave this blank to accept a calculated value), C = <input type="text"/>		C = <input type="text"/>	
User-Defined 5-yr. Runoff Coefficient (leave this blank to accept a calculated value), C_5 = <input type="text"/>		C_5 = <input type="text"/>	
		Bypass (Carry-Over) Flow from upstream Subcatchments, Q_b = <input type="text" value="0.0"/> <input type="text" value="0.5"/> cfs	
		Total Design Peak Flow, Q = <input type="text" value="3.9"/> <input type="text" value="11.2"/> cfs	

ALLOWABLE CAPACITY FOR ONE-HALF OF STREET (Minor & Major Storm)

(Based on Regulated Criteria for Maximum Allowable Flow Depth and Spread)

Project: **COMPARK SOUTH**

Inlet ID: **INLET 3-4**

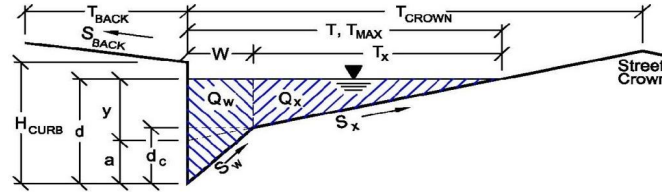

Gutter Geometry (Enter data in the blue cells)																	
Maximum Allowable Width for Spread Behind Curb	$T_{BACK} =$ <input style="width: 50px;" type="text" value="0.0"/> ft																
Side Slope Behind Curb (leave blank for no conveyance credit behind curb)	$S_{BACK} =$ <input style="width: 50px;" type="text" value="0.020"/> ft/ft																
Manning's Roughness Behind Curb (typically between 0.012 and 0.020)	$n_{BACK} =$ <input style="width: 50px;" type="text" value="0.020"/>																
Height of Curb at Gutter Flow Line	$H_{CURB} =$ <input style="width: 50px;" type="text" value="4.00"/> inches																
Distance from Curb Face to Street Crown	$T_{CROWN} =$ <input style="width: 50px;" type="text" value="17.0"/> ft																
Gutter Width	$W =$ <input style="width: 50px;" type="text" value="2.00"/> ft																
Street Transverse Slope	$S_x =$ <input style="width: 50px;" type="text" value="0.020"/> ft/ft																
Gutter Cross Slope (typically 2 inches over 24 inches or 0.083 ft/ft)	$S_w =$ <input style="width: 50px;" type="text" value="0.083"/> ft/ft																
Street Longitudinal Slope - Enter 0 for sump condition	$S_o =$ <input style="width: 50px;" type="text" value="0.000"/> ft/ft																
Manning's Roughness for Street Section (typically between 0.012 and 0.020)	$n_{STREET} =$ <input style="width: 50px;" type="text" value="0.016"/>																
Max. Allowable Spread for Minor & Major Storm	<table style="width: 100%; border-collapse: collapse;"> <thead> <tr> <th style="width: 50%;"></th> <th style="width: 25%; text-align: center;">Minor Storm</th> <th style="width: 25%; text-align: center;">Major Storm</th> <th style="width: 10%;"></th> </tr> </thead> <tbody> <tr> <td>$T_{MAX} =$</td> <td style="text-align: center;"><input style="width: 50px;" type="text" value="17.0"/></td> <td style="text-align: center;"><input style="width: 50px;" type="text" value="17.0"/></td> <td style="text-align: right;">ft</td> </tr> <tr> <td>$d_{MAX} =$</td> <td style="text-align: center;"><input style="width: 50px;" type="text" value="4.0"/></td> <td style="text-align: center;"><input style="width: 50px;" type="text" value="12.0"/></td> <td style="text-align: right;">inches</td> </tr> <tr> <td></td> <td style="text-align: center;"><input type="checkbox"/></td> <td style="text-align: center;"><input checked="" type="checkbox"/></td> <td style="text-align: right;">check = yes</td> </tr> </tbody> </table>		Minor Storm	Major Storm		$T_{MAX} =$	<input style="width: 50px;" type="text" value="17.0"/>	<input style="width: 50px;" type="text" value="17.0"/>	ft	$d_{MAX} =$	<input style="width: 50px;" type="text" value="4.0"/>	<input style="width: 50px;" type="text" value="12.0"/>	inches		<input type="checkbox"/>	<input checked="" type="checkbox"/>	check = yes
	Minor Storm	Major Storm															
$T_{MAX} =$	<input style="width: 50px;" type="text" value="17.0"/>	<input style="width: 50px;" type="text" value="17.0"/>	ft														
$d_{MAX} =$	<input style="width: 50px;" type="text" value="4.0"/>	<input style="width: 50px;" type="text" value="12.0"/>	inches														
	<input type="checkbox"/>	<input checked="" type="checkbox"/>	check = yes														
Max. Allowable Depth at Gutter Flowline for Minor & Major Storm																	
Allow Flow Depth at Street Crown (leave blank for no)																	
MINOR STORM Allowable Capacity is based on Depth Criterion																	
MAJOR STORM Allowable Capacity is based on Depth Criterion																	
Minor storm max. allowable capacity GOOD - greater than flow given on sheet 'Q-Peak'																	
Major storm max. allowable capacity GOOD - greater than flow given on sheet 'Q-Peak'																	
$Q_{allow} =$	<table style="width: 100%; border-collapse: collapse;"> <thead> <tr> <th style="width: 50%;"></th> <th style="width: 25%; text-align: center;">Minor Storm</th> <th style="width: 25%; text-align: center;">Major Storm</th> <th style="width: 10%;"></th> </tr> </thead> <tbody> <tr> <td></td> <td style="text-align: center;"><input style="width: 50px;" type="text" value="SUMP"/></td> <td style="text-align: center;"><input style="width: 50px;" type="text" value="SUMP"/></td> <td style="text-align: right;">cfs</td> </tr> </tbody> </table>		Minor Storm	Major Storm			<input style="width: 50px;" type="text" value="SUMP"/>	<input style="width: 50px;" type="text" value="SUMP"/>	cfs								
	Minor Storm	Major Storm															
	<input style="width: 50px;" type="text" value="SUMP"/>	<input style="width: 50px;" type="text" value="SUMP"/>	cfs														

INLET IN A SUMP OR SAG LOCATION

Project = **COMPARK SOUTH**
 Inlet ID = **INLET 3-4**

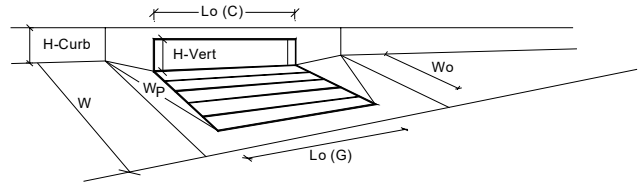

Design Information (Input)	MINOR		MAJOR	
	Type of Inlet	CDOT Type R Curb Opening		
Local Depression (additional to continuous gutter depression 'a' from 'Q-Allow')	a_{local} =	5.00	5.00	inches
Number of Unit Inlets (Grate or Curb Opening)	N_o =	3	3	
Water Depth at Flowline (outside of local depression)	Ponding Depth =	4.0	12.0	inches
Grate Information	<input checked="" type="checkbox"/> Override Depths			
Length of a Unit Grate	$L_o (G)$ =	N/A	N/A	feet
Width of a Unit Grate	W_o =	N/A	N/A	feet
Area Opening Ratio for a Grate (typical values 0.15-0.90)	A_{ratio} =	N/A	N/A	
Clogging Factor for a Single Grate (typical value 0.50 - 0.70)	$C_r (G)$ =	N/A	N/A	
Grate Weir Coefficient (typical value 2.15 - 3.60)	$C_w (G)$ =	N/A	N/A	
Grate Orifice Coefficient (typical value 0.60 - 0.80)	$C_o (G)$ =	N/A	N/A	
Curb Opening Information				
Length of a Unit Curb Opening	$L_o (C)$ =	5.00	5.00	feet
Height of Vertical Curb Opening in Inches	H_{vert} =	6.00	6.00	inches
Height of Curb Orifice Throat in Inches	H_{throat} =	6.00	6.00	inches
Angle of Throat (see USDCM Figure ST-5)	Theta =	63.40	63.40	degrees
Side Width for Depression Pan (typically the gutter width of 2 feet)	W_p =	2.00	2.00	feet
Clogging Factor for a Single Curb Opening (typical value 0.10)	$C_r (C)$ =	0.10	0.10	
Curb Opening Weir Coefficient (typical value 2.3-3.7)	$C_w (C)$ =	3.60	3.60	
Curb Opening Orifice Coefficient (typical value 0.60 - 0.70)	$C_o (C)$ =	0.67	0.67	
Total Inlet Interception Capacity (assumes clogged condition)				
Inlet Capacity IS GOOD for Minor and Major Storms (>Q PEAK)	Q_a =	3.9	42.1	cfs
	$Q_{PEAK REQUIRED}$ =	3.9	11.2	cfs

**DESIGN PEAK FLOW FOR ONE-HALF OF STREET
OR GRASS-LINED CHANNEL BY THE RATIONAL METHOD**

Project: COMPARK SOUTH
 Inlet ID: INLET 3-5

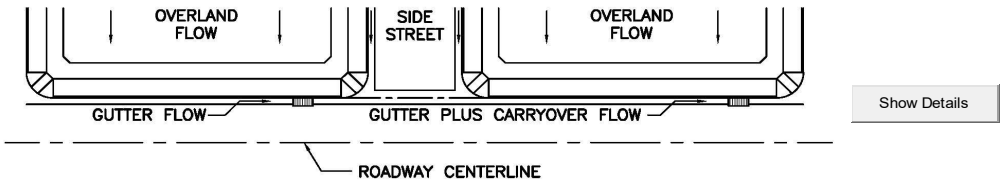

<p>Design Flow: ONLY if already determined through other methods: (local peak flow for 1/2 of street OR grass-lined channel):</p>		<table border="1" style="display: inline-table; border-collapse: collapse;"> <tr> <td style="padding: 2px;">Minor Storm</td> <td style="padding: 2px;">Major Storm</td> </tr> <tr> <td style="text-align: center;">3.9</td> <td style="text-align: center;">11.0</td> </tr> <tr> <td colspan="2" style="text-align: right; padding-right: 5px;">cfs</td> </tr> </table>	Minor Storm	Major Storm	3.9	11.0	cfs		<--- FILL IN THIS SECTION OR...																			
Minor Storm	Major Storm																											
3.9	11.0																											
cfs																												
<p>Geographic Information: (Enter data in the blue cells):</p>		<table style="width: 100%; border-collapse: collapse;"> <tr> <td style="width: 50%; border-collapse: collapse;"> <table style="width: 100%; border-collapse: collapse;"> <tr> <td style="width: 50%; border-collapse: collapse;"> <table border="1" style="width: 100%; border-collapse: collapse;"> <tr> <td style="padding: 2px;">Site Type:</td> </tr> <tr> <td style="padding: 2px;"><input type="radio"/> Site is Urban</td> </tr> <tr> <td style="padding: 2px;"><input type="radio"/> Site is Non-Urban</td> </tr> </table> </td> <td style="width: 50%; border-collapse: collapse;"> <table style="width: 100%; border-collapse: collapse;"> <tr> <td style="padding: 2px;">Flows Developed For:</td> </tr> <tr> <td style="padding: 2px;"><input type="radio"/> Street Inlets</td> </tr> <tr> <td style="padding: 2px;"><input type="radio"/> Area Inlets in a Median</td> </tr> </table> </td> </tr> </table> </td> <td style="width: 50%; border-collapse: collapse;"> <table style="width: 100%; border-collapse: collapse;"> <tr> <td style="padding: 2px;">Subcatchment Area =</td> <td style="border: 1px solid black; width: 50px;"></td> <td style="padding: 2px;">Acres</td> </tr> <tr> <td style="padding: 2px;">Percent Imperviousness =</td> <td style="border: 1px solid black; width: 50px;"></td> <td style="padding: 2px;">%</td> </tr> <tr> <td style="padding: 2px;">NRCS Soil Type =</td> <td style="border: 1px solid black; width: 50px;"></td> <td style="padding: 2px;">A, B, C, or D</td> </tr> </table> <table style="width: 100%; border-collapse: collapse; margin-top: 5px;"> <tr> <td style="padding: 2px;">Overland Flow =</td> <td style="border: 1px solid black; width: 50px;"></td> <td style="border: 1px solid black; width: 50px;"></td> </tr> <tr> <td style="padding: 2px;">Channel Flow =</td> <td style="border: 1px solid black; width: 50px;"></td> <td style="border: 1px solid black; width: 50px;"></td> </tr> </table> </td> </tr> </table>	<table style="width: 100%; border-collapse: collapse;"> <tr> <td style="width: 50%; border-collapse: collapse;"> <table border="1" style="width: 100%; border-collapse: collapse;"> <tr> <td style="padding: 2px;">Site Type:</td> </tr> <tr> <td style="padding: 2px;"><input type="radio"/> Site is Urban</td> </tr> <tr> <td style="padding: 2px;"><input type="radio"/> Site is Non-Urban</td> </tr> </table> </td> <td style="width: 50%; border-collapse: collapse;"> <table style="width: 100%; border-collapse: collapse;"> <tr> <td style="padding: 2px;">Flows Developed For:</td> </tr> <tr> <td style="padding: 2px;"><input type="radio"/> Street Inlets</td> </tr> <tr> <td style="padding: 2px;"><input type="radio"/> Area Inlets in a Median</td> </tr> </table> </td> </tr> </table>	<table border="1" style="width: 100%; border-collapse: collapse;"> <tr> <td style="padding: 2px;">Site Type:</td> </tr> <tr> <td style="padding: 2px;"><input type="radio"/> Site is Urban</td> </tr> <tr> <td style="padding: 2px;"><input type="radio"/> Site is Non-Urban</td> </tr> </table>	Site Type:	<input type="radio"/> Site is Urban	<input type="radio"/> Site is Non-Urban	<table style="width: 100%; border-collapse: collapse;"> <tr> <td style="padding: 2px;">Flows Developed For:</td> </tr> <tr> <td style="padding: 2px;"><input type="radio"/> Street Inlets</td> </tr> <tr> <td style="padding: 2px;"><input type="radio"/> Area Inlets in a Median</td> </tr> </table>	Flows Developed For:	<input type="radio"/> Street Inlets	<input type="radio"/> Area Inlets in a Median	<table style="width: 100%; border-collapse: collapse;"> <tr> <td style="padding: 2px;">Subcatchment Area =</td> <td style="border: 1px solid black; width: 50px;"></td> <td style="padding: 2px;">Acres</td> </tr> <tr> <td style="padding: 2px;">Percent Imperviousness =</td> <td style="border: 1px solid black; width: 50px;"></td> <td style="padding: 2px;">%</td> </tr> <tr> <td style="padding: 2px;">NRCS Soil Type =</td> <td style="border: 1px solid black; width: 50px;"></td> <td style="padding: 2px;">A, B, C, or D</td> </tr> </table> <table style="width: 100%; border-collapse: collapse; margin-top: 5px;"> <tr> <td style="padding: 2px;">Overland Flow =</td> <td style="border: 1px solid black; width: 50px;"></td> <td style="border: 1px solid black; width: 50px;"></td> </tr> <tr> <td style="padding: 2px;">Channel Flow =</td> <td style="border: 1px solid black; width: 50px;"></td> <td style="border: 1px solid black; width: 50px;"></td> </tr> </table>	Subcatchment Area =		Acres	Percent Imperviousness =		%	NRCS Soil Type =		A, B, C, or D	Overland Flow =			Channel Flow =			FILL IN THE SECTIONS BELOW. <---
<table style="width: 100%; border-collapse: collapse;"> <tr> <td style="width: 50%; border-collapse: collapse;"> <table border="1" style="width: 100%; border-collapse: collapse;"> <tr> <td style="padding: 2px;">Site Type:</td> </tr> <tr> <td style="padding: 2px;"><input type="radio"/> Site is Urban</td> </tr> <tr> <td style="padding: 2px;"><input type="radio"/> Site is Non-Urban</td> </tr> </table> </td> <td style="width: 50%; border-collapse: collapse;"> <table style="width: 100%; border-collapse: collapse;"> <tr> <td style="padding: 2px;">Flows Developed For:</td> </tr> <tr> <td style="padding: 2px;"><input type="radio"/> Street Inlets</td> </tr> <tr> <td style="padding: 2px;"><input type="radio"/> Area Inlets in a Median</td> </tr> </table> </td> </tr> </table>	<table border="1" style="width: 100%; border-collapse: collapse;"> <tr> <td style="padding: 2px;">Site Type:</td> </tr> <tr> <td style="padding: 2px;"><input type="radio"/> Site is Urban</td> </tr> <tr> <td style="padding: 2px;"><input type="radio"/> Site is Non-Urban</td> </tr> </table>	Site Type:	<input type="radio"/> Site is Urban	<input type="radio"/> Site is Non-Urban	<table style="width: 100%; border-collapse: collapse;"> <tr> <td style="padding: 2px;">Flows Developed For:</td> </tr> <tr> <td style="padding: 2px;"><input type="radio"/> Street Inlets</td> </tr> <tr> <td style="padding: 2px;"><input type="radio"/> Area Inlets in a Median</td> </tr> </table>	Flows Developed For:	<input type="radio"/> Street Inlets	<input type="radio"/> Area Inlets in a Median	<table style="width: 100%; border-collapse: collapse;"> <tr> <td style="padding: 2px;">Subcatchment Area =</td> <td style="border: 1px solid black; width: 50px;"></td> <td style="padding: 2px;">Acres</td> </tr> <tr> <td style="padding: 2px;">Percent Imperviousness =</td> <td style="border: 1px solid black; width: 50px;"></td> <td style="padding: 2px;">%</td> </tr> <tr> <td style="padding: 2px;">NRCS Soil Type =</td> <td style="border: 1px solid black; width: 50px;"></td> <td style="padding: 2px;">A, B, C, or D</td> </tr> </table> <table style="width: 100%; border-collapse: collapse; margin-top: 5px;"> <tr> <td style="padding: 2px;">Overland Flow =</td> <td style="border: 1px solid black; width: 50px;"></td> <td style="border: 1px solid black; width: 50px;"></td> </tr> <tr> <td style="padding: 2px;">Channel Flow =</td> <td style="border: 1px solid black; width: 50px;"></td> <td style="border: 1px solid black; width: 50px;"></td> </tr> </table>	Subcatchment Area =		Acres	Percent Imperviousness =		%	NRCS Soil Type =		A, B, C, or D	Overland Flow =			Channel Flow =						
<table border="1" style="width: 100%; border-collapse: collapse;"> <tr> <td style="padding: 2px;">Site Type:</td> </tr> <tr> <td style="padding: 2px;"><input type="radio"/> Site is Urban</td> </tr> <tr> <td style="padding: 2px;"><input type="radio"/> Site is Non-Urban</td> </tr> </table>	Site Type:	<input type="radio"/> Site is Urban	<input type="radio"/> Site is Non-Urban	<table style="width: 100%; border-collapse: collapse;"> <tr> <td style="padding: 2px;">Flows Developed For:</td> </tr> <tr> <td style="padding: 2px;"><input type="radio"/> Street Inlets</td> </tr> <tr> <td style="padding: 2px;"><input type="radio"/> Area Inlets in a Median</td> </tr> </table>	Flows Developed For:	<input type="radio"/> Street Inlets	<input type="radio"/> Area Inlets in a Median																					
Site Type:																												
<input type="radio"/> Site is Urban																												
<input type="radio"/> Site is Non-Urban																												
Flows Developed For:																												
<input type="radio"/> Street Inlets																												
<input type="radio"/> Area Inlets in a Median																												
Subcatchment Area =		Acres																										
Percent Imperviousness =		%																										
NRCS Soil Type =		A, B, C, or D																										
Overland Flow =																												
Channel Flow =																												
<p>Rainfall Information: Intensity I (inch/hr) = $C_1 * P_1 / (C_2 + T_c)^{C_3}$</p>		<table border="1" style="display: inline-table; border-collapse: collapse;"> <tr> <td style="padding: 2px;">Minor Storm</td> <td style="padding: 2px;">Major Storm</td> </tr> <tr> <td style="padding: 2px;">Design Storm Return Period, T_r =</td> <td style="padding: 2px;"></td> </tr> <tr> <td style="padding: 2px;">Return Period One-Hour Precipitation, P_1 =</td> <td style="padding: 2px;"></td> </tr> <tr> <td style="padding: 2px;">C_1 =</td> <td style="padding: 2px;"></td> </tr> <tr> <td style="padding: 2px;">C_2 =</td> <td style="padding: 2px;"></td> </tr> <tr> <td style="padding: 2px;">C_3 =</td> <td style="padding: 2px;"></td> </tr> <tr> <td style="padding: 2px;">User-Defined Storm Runoff Coefficient (leave this blank to accept a calculated value), C =</td> <td style="padding: 2px;"></td> </tr> <tr> <td style="padding: 2px;">User-Defined 5-yr. Runoff Coefficient (leave this blank to accept a calculated value), C_5 =</td> <td style="padding: 2px;"></td> </tr> <tr> <td style="padding: 2px;">Bypass (Carry-Over) Flow from upstream Subcatchments, Q_b =</td> <td style="padding: 2px; text-align: center;">0.0</td> </tr> <tr> <td style="padding: 2px;">Total Design Peak Flow, Q =</td> <td style="padding: 2px; text-align: center;">3.9</td> </tr> <tr> <td style="padding: 2px;"></td> <td style="padding: 2px; text-align: center;">11.0</td> </tr> <tr> <td colspan="2" style="text-align: right; padding-right: 5px;">cfs</td> </tr> </table>	Minor Storm	Major Storm	Design Storm Return Period, T_r =		Return Period One-Hour Precipitation, P_1 =		C_1 =		C_2 =		C_3 =		User-Defined Storm Runoff Coefficient (leave this blank to accept a calculated value), C =		User-Defined 5-yr. Runoff Coefficient (leave this blank to accept a calculated value), C_5 =		Bypass (Carry-Over) Flow from upstream Subcatchments, Q_b =	0.0	Total Design Peak Flow, Q =	3.9		11.0	cfs			
Minor Storm	Major Storm																											
Design Storm Return Period, T_r =																												
Return Period One-Hour Precipitation, P_1 =																												
C_1 =																												
C_2 =																												
C_3 =																												
User-Defined Storm Runoff Coefficient (leave this blank to accept a calculated value), C =																												
User-Defined 5-yr. Runoff Coefficient (leave this blank to accept a calculated value), C_5 =																												
Bypass (Carry-Over) Flow from upstream Subcatchments, Q_b =	0.0																											
Total Design Peak Flow, Q =	3.9																											
	11.0																											
cfs																												

ALLOWABLE CAPACITY FOR ONE-HALF OF STREET (Minor & Major Storm)

(Based on Regulated Criteria for Maximum Allowable Flow Depth and Spread)

Project:

COMPARK SOUTH

Inlet ID:

INLET 3-5

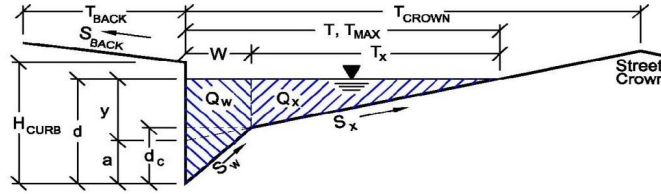

Gutter Geometry (Enter data in the blue cells)													
Maximum Allowable Width for Spread Behind Curb	$T_{BACK} = 0.0$ ft												
Side Slope Behind Curb (leave blank for no conveyance credit behind curb)	$S_{BACK} = 0.020$ ft/ft												
Manning's Roughness Behind Curb (typically between 0.012 and 0.020)	$n_{BACK} = 0.020$												
Height of Curb at Gutter Flow Line	$H_{CURB} = 4.00$ inches												
Distance from Curb Face to Street Crown	$T_{CROWN} = 17.0$ ft												
Gutter Width	$W = 2.00$ ft												
Street Transverse Slope	$S_x = 0.020$ ft/ft												
Gutter Cross Slope (typically 2 inches over 24 inches or 0.083 ft/ft)	$S_w = 0.083$ ft/ft												
Street Longitudinal Slope - Enter 0 for sump condition	$S_o = 0.000$ ft/ft												
Manning's Roughness for Street Section (typically between 0.012 and 0.020)	$n_{STREET} = 0.016$												
Max. Allowable Spread for Minor & Major Storm	<table border="1" style="display: inline-table; border-collapse: collapse;"> <thead> <tr> <th></th> <th>Minor Storm</th> <th>Major Storm</th> <th></th> </tr> </thead> <tbody> <tr> <td>$T_{MAX} =$</td> <td>17.0</td> <td>17.0</td> <td>ft</td> </tr> <tr> <td>$d_{MAX} =$</td> <td>4.0</td> <td>12.0</td> <td>inches</td> </tr> </tbody> </table>		Minor Storm	Major Storm		$T_{MAX} =$	17.0	17.0	ft	$d_{MAX} =$	4.0	12.0	inches
	Minor Storm	Major Storm											
$T_{MAX} =$	17.0	17.0	ft										
$d_{MAX} =$	4.0	12.0	inches										
Max. Allowable Depth at Gutter Flowline for Minor & Major Storm													
Allow Flow Depth at Street Crown (leave blank for no)	<input type="checkbox"/> <input type="checkbox"/> check = yes												
MINOR STORM Allowable Capacity is based on Depth Criterion													
MAJOR STORM Allowable Capacity is based on Depth Criterion													
Minor storm max. allowable capacity GOOD - greater than flow given on sheet 'Q-Peak'													
Major storm max. allowable capacity GOOD - greater than flow given on sheet 'Q-Peak'													
$Q_{allow} =$	<table border="1" style="display: inline-table; border-collapse: collapse;"> <thead> <tr> <th></th> <th>Minor Storm</th> <th>Major Storm</th> <th></th> </tr> </thead> <tbody> <tr> <td></td> <td>SUMP</td> <td>SUMP</td> <td>cfs</td> </tr> </tbody> </table>		Minor Storm	Major Storm			SUMP	SUMP	cfs				
	Minor Storm	Major Storm											
	SUMP	SUMP	cfs										

INLET IN A SUMP OR SAG LOCATION

Project = **COMPARK SOUTH**
 Inlet ID = **INLET 3-5**

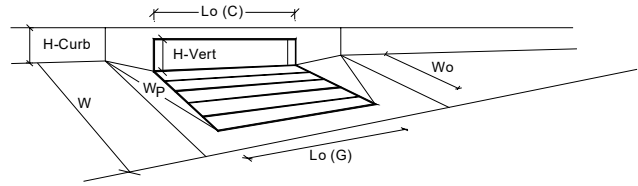

Design Information (Input)	MINOR		MAJOR		
	MINOR	MAJOR	MINOR	MAJOR	
Type of Inlet	CDOT Type R Curb Opening				
Local Depression (additional to continuous gutter depression 'a' from 'Q-Allow')	a _{local} = 5.00	5.00	5.00	5.00	inches
Number of Unit Inlets (Grate or Curb Opening)	No = 3	3	3	3	
Water Depth at Flowline (outside of local depression)	Ponding Depth = 4.0	12.0	12.0	12.0	inches <input checked="" type="checkbox"/> Override Depths
Grate Information	MINOR		MAJOR		
Length of a Unit Grate	L _o (G) = N/A	N/A	N/A	N/A	feet
Width of a Unit Grate	W _o = N/A	N/A	N/A	N/A	feet
Area Opening Ratio for a Grate (typical values 0.15-0.90)	A _{ratio} = N/A	N/A	N/A	N/A	
Clogging Factor for a Single Grate (typical value 0.50 - 0.70)	C _r (G) = N/A	N/A	N/A	N/A	
Grate Weir Coefficient (typical value 2.15 - 3.60)	C _w (G) = N/A	N/A	N/A	N/A	
Grate Orifice Coefficient (typical value 0.60 - 0.80)	C _o (G) = N/A	N/A	N/A	N/A	
Curb Opening Information	MINOR		MAJOR		
Length of a Unit Curb Opening	L _o (C) = 5.00	5.00	5.00	5.00	feet
Height of Vertical Curb Opening in Inches	H _{vert} = 6.00	6.00	6.00	6.00	inches
Height of Curb Orifice Throat in Inches	H _{throat} = 6.00	6.00	6.00	6.00	inches
Angle of Throat (see USDCM Figure ST-5)	Theta = 63.40	63.40	63.40	63.40	degrees
Side Width for Depression Pan (typically the gutter width of 2 feet)	W _p = 2.00	2.00	2.00	2.00	feet
Clogging Factor for a Single Curb Opening (typical value 0.10)	C _r (C) = 0.10	0.10	0.10	0.10	
Curb Opening Weir Coefficient (typical value 2.3-3.7)	C _w (C) = 3.60	3.60	3.60	3.60	
Curb Opening Orifice Coefficient (typical value 0.60 - 0.70)	C _o (C) = 0.67	0.67	0.67	0.67	
Total Inlet Interception Capacity (assumes clogged condition)	MINOR		MAJOR		
	Q _a = 3.9	42.1	42.1	42.1	cfs
Inlet Capacity IS GOOD for Minor and Major Storms (>Q PEAK)	Q _{PEAK REQUIRED} = 3.9	11.0	11.0	11.0	cfs

**DESIGN PEAK FLOW FOR ONE-HALF OF STREET
OR GRASS-LINED CHANNEL BY THE RATIONAL METHOD**

Project: COMPARK SOUTH
Inlet ID: INLET 4-4

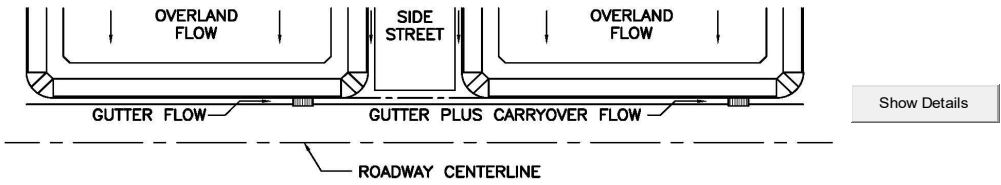

Design Flow: ONLY if already determined through other methods: (local peak flow for 1/2 of street OR grass-lined channel):		Minor Storm Major Storm * Q_{known} = <input type="text" value="0.9"/> <input type="text" value="2.4"/> cfs	<--- FILL IN THIS SECTION OR... FILL IN THE SECTIONS BELOW. <---
Geographic Information: (Enter data in the blue cells):		Subcatchment Area = <input type="text"/> Acres Percent Imperviousness = <input type="text"/> % NRCS Soil Type = <input type="text"/> A, B, C, or D	
Site Type: <input type="radio"/> Site is Urban <input type="radio"/> Site is Non-Urban	Flows Developed For: <input type="radio"/> Street Inlets <input type="radio"/> Area Inlets in a Median	Slope (ft/ft) Length (ft) Overland Flow = <input type="text"/> <input type="text"/> Channel Flow = <input type="text"/> <input type="text"/>	
Rainfall Information: Intensity I (inch/hr) = $C_1 * P_1 / (C_2 + T_c)^{C_3}$		Minor Storm Major Storm	
		Design Storm Return Period, T_r = <input type="text"/> years	
		Return Period One-Hour Precipitation, P_1 = <input type="text"/> inches	
		C_1 = <input type="text"/>	
		C_2 = <input type="text"/>	
		C_3 = <input type="text"/>	
User-Defined Storm Runoff Coefficient (leave this blank to accept a calculated value), C = <input type="text"/>		C_4 = <input type="text"/>	
User-Defined 5-yr. Runoff Coefficient (leave this blank to accept a calculated value), C_5 = <input type="text"/>		C_5 = <input type="text"/>	
Bypass (Carry-Over) Flow from upstream Subcatchments, Q_b =		<input type="text" value="0.0"/> <input type="text" value="0.0"/> cfs	
Total Design Peak Flow, Q =		<input type="text" value="0.9"/> <input type="text" value="2.4"/> cfs	

ALLOWABLE CAPACITY FOR ONE-HALF OF STREET (Minor & Major Storm)

(Based on Regulated Criteria for Maximum Allowable Flow Depth and Spread)

Project: COMPARK SOUTH
 Inlet ID: INLET 4-4

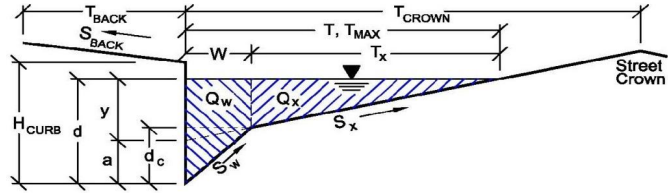

Gutter Geometry (Enter data in the blue cells)					
Maximum Allowable Width for Spread Behind Curb	$T_{BACK} = 0.0$ ft				
Side Slope Behind Curb (leave blank for no conveyance credit behind curb)	$S_{BACK} = 0.020$ ft/ft				
Manning's Roughness Behind Curb (typically between 0.012 and 0.020)	$n_{BACK} = 0.020$				
Height of Curb at Gutter Flow Line	$H_{CURB} = 4.00$ inches				
Distance from Curb Face to Street Crown	$T_{CROWN} = 17.0$ ft				
Gutter Width	$W = 2.00$ ft				
Street Transverse Slope	$S_x = 0.020$ ft/ft				
Gutter Cross Slope (typically 2 inches over 24 inches or 0.083 ft/ft)	$S_w = 0.083$ ft/ft				
Street Longitudinal Slope - Enter 0 for sump condition	$S_o = 0.000$ ft/ft				
Manning's Roughness for Street Section (typically between 0.012 and 0.020)	$n_{STREET} = 0.016$				
Max. Allowable Spread for Minor & Major Storm	$T_{MAX} = $ <table border="1" style="display: inline-table;"> <tr> <th>Minor Storm</th> <th>Major Storm</th> </tr> <tr> <td>17.0</td> <td>17.0</td> </tr> </table> ft	Minor Storm	Major Storm	17.0	17.0
Minor Storm	Major Storm				
17.0	17.0				
Max. Allowable Depth at Gutter Flowline for Minor & Major Storm	$d_{MAX} = $ <table border="1" style="display: inline-table;"> <tr> <th>Minor Storm</th> <th>Major Storm</th> </tr> <tr> <td>4.0</td> <td>12.0</td> </tr> </table> inches	Minor Storm	Major Storm	4.0	12.0
Minor Storm	Major Storm				
4.0	12.0				
Allow Flow Depth at Street Crown (leave blank for no)	<input type="checkbox"/> <input checked="" type="checkbox"/> check = yes				
MINOR STORM Allowable Capacity is based on Depth Criterion					
MAJOR STORM Allowable Capacity is based on Depth Criterion					
Minor storm max. allowable capacity GOOD - greater than flow given on sheet 'Q-Peak'					
Major storm max. allowable capacity GOOD - greater than flow given on sheet 'Q-Peak'					
$Q_{allow} = $	<table border="1" style="display: inline-table;"> <tr> <th>Minor Storm</th> <th>Major Storm</th> </tr> <tr> <td>SUMP</td> <td>SUMP</td> </tr> </table> cfs	Minor Storm	Major Storm	SUMP	SUMP
Minor Storm	Major Storm				
SUMP	SUMP				

INLET IN A SUMP OR SAG LOCATION

Project = **COMPARK SOUTH**
 Inlet ID = **INLET 4-4**

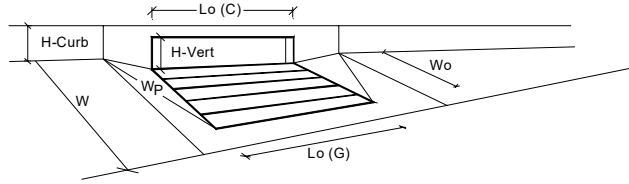

Design Information (Input)		MINOR		MAJOR	
Type of Inlet	Inlet Type =	CDOT Type R Curb Opening			
Local Depression (additional to continuous gutter depression 'a' from 'Q-Allow')	a_{local} =	5.00	5.00	inches	
Number of Unit Inlets (Grate or Curb Opening)	N_o =	1	1		
Water Depth at Flowline (outside of local depression)	Ponding Depth =	4.0	12.0	inches	<input checked="" type="checkbox"/> Override Depths
Grate Information		MINOR		MAJOR	
Length of a Unit Grate	$L_o (G)$ =	N/A	N/A	feet	
Width of a Unit Grate	W_o =	N/A	N/A	feet	
Area Opening Ratio for a Grate (typical values 0.15-0.90)	A_{ratio} =	N/A	N/A		
Clogging Factor for a Single Grate (typical value 0.50 - 0.70)	$C_r (G)$ =	N/A	N/A		
Grate Weir Coefficient (typical value 2.15 - 3.60)	$C_w (G)$ =	N/A	N/A		
Grate Orifice Coefficient (typical value 0.60 - 0.80)	$C_o (G)$ =	N/A	N/A		
Curb Opening Information		MINOR		MAJOR	
Length of a Unit Curb Opening	$L_o (C)$ =	5.00	5.00	feet	
Height of Vertical Curb Opening in Inches	H_{vert} =	6.00	6.00	inches	
Height of Curb Orifice Throat in Inches	H_{throat} =	6.00	6.00	inches	
Angle of Throat (see USDCM Figure ST-5)	Theta =	63.40	63.40	degrees	
Side Width for Depression Pan (typically the gutter width of 2 feet)	W_p =	2.00	2.00	feet	
Clogging Factor for a Single Curb Opening (typical value 0.10)	$C_r (C)$ =	0.10	0.10		
Curb Opening Weir Coefficient (typical value 2.3-3.7)	$C_w (C)$ =	3.60	3.60		
Curb Opening Orifice Coefficient (typical value 0.60 - 0.70)	$C_o (C)$ =	0.67	0.67		
Total Inlet Interception Capacity (assumes clogged condition)		MINOR		MAJOR	
	Q_a =	1.9	13.2	cfs	
Inlet Capacity IS GOOD for Minor and Major Storms (>Q PEAK)	$Q_{PEAK REQUIRED}$ =	0.9	2.4	cfs	

**DESIGN PEAK FLOW FOR ONE-HALF OF STREET
OR GRASS-LINED CHANNEL BY THE RATIONAL METHOD**

Project: COMPARK SOUTH
 Inlet ID: INLET 4-5

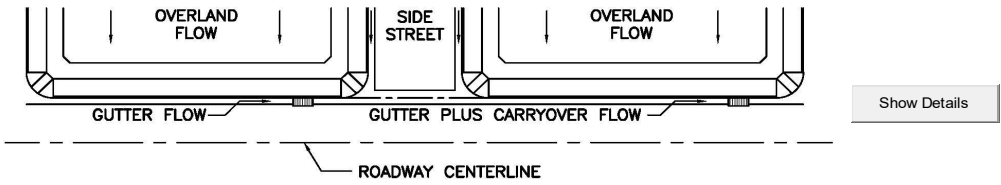

Design Flow: ONLY if already determined through other methods: (local peak flow for 1/2 of street OR grass-lined channel):		<table border="1" style="display: inline-table; border-collapse: collapse;"> <tr> <td style="padding: 2px;">Minor Storm</td> <td style="padding: 2px;">Major Storm</td> </tr> <tr> <td style="text-align: center;">2.4</td> <td style="text-align: center;">6.6</td> </tr> </table> cfs	Minor Storm	Major Storm	2.4	6.6	<--- FILL IN THIS SECTION OR... FILL IN THE SECTIONS BELOW. <---												
Minor Storm	Major Storm																		
2.4	6.6																		
* If you enter values in Row 14, skip the rest of this sheet and proceed to sheet Q-Allow or Area Inlet.																			
Geographic Information: (Enter data in the blue cells):																			
Site Type: <input type="radio"/> Site is Urban <input type="radio"/> Site is Non-Urban	Flows Developed For: <input type="radio"/> Street Inlets <input type="radio"/> Area Inlets in a Median	Subcatchment Area = <input type="text"/> Acres Percent Imperviousness = <input type="text"/> % NRCS Soil Type = <input type="text"/> A, B, C, or D																	
		<table border="1" style="display: inline-table; border-collapse: collapse;"> <tr> <td style="padding: 2px;">Slope (ft/ft)</td> <td style="padding: 2px;">Length (ft)</td> </tr> <tr> <td style="padding: 2px;">Overland Flow =</td> <td style="padding: 2px;">Channel Flow =</td> </tr> </table>	Slope (ft/ft)	Length (ft)	Overland Flow =	Channel Flow =													
Slope (ft/ft)	Length (ft)																		
Overland Flow =	Channel Flow =																		
Rainfall Information: Intensity I (inch/hr) = $C_1 * P_1 / (C_2 + T_c)^{C_3}$		<table border="1" style="display: inline-table; border-collapse: collapse;"> <tr> <td style="padding: 2px;">Minor Storm</td> <td style="padding: 2px;">Major Storm</td> </tr> <tr> <td style="padding: 2px;">Design Storm Return Period, T_r =</td> <td style="padding: 2px;">years</td> </tr> <tr> <td style="padding: 2px;">Return Period One-Hour Precipitation, P₁ =</td> <td style="padding: 2px;">inches</td> </tr> <tr> <td style="padding: 2px;">C₁ =</td> <td style="padding: 2px;"></td> </tr> <tr> <td style="padding: 2px;">C₂ =</td> <td style="padding: 2px;"></td> </tr> <tr> <td style="padding: 2px;">C₃ =</td> <td style="padding: 2px;"></td> </tr> <tr> <td style="padding: 2px;">User-Defined Storm Runoff Coefficient (leave this blank to accept a calculated value), C =</td> <td style="padding: 2px;"></td> </tr> <tr> <td style="padding: 2px;">User-Defined 5-yr. Runoff Coefficient (leave this blank to accept a calculated value), C₅ =</td> <td style="padding: 2px;"></td> </tr> </table>	Minor Storm	Major Storm	Design Storm Return Period, T _r =	years	Return Period One-Hour Precipitation, P ₁ =	inches	C ₁ =		C ₂ =		C ₃ =		User-Defined Storm Runoff Coefficient (leave this blank to accept a calculated value), C =		User-Defined 5-yr. Runoff Coefficient (leave this blank to accept a calculated value), C ₅ =		
Minor Storm	Major Storm																		
Design Storm Return Period, T _r =	years																		
Return Period One-Hour Precipitation, P ₁ =	inches																		
C ₁ =																			
C ₂ =																			
C ₃ =																			
User-Defined Storm Runoff Coefficient (leave this blank to accept a calculated value), C =																			
User-Defined 5-yr. Runoff Coefficient (leave this blank to accept a calculated value), C ₅ =																			
		Bypass (Carry-Over) Flow from upstream Subcatchments, Q _b = <table border="1" style="display: inline-table; border-collapse: collapse;"><tr><td style="padding: 2px;">0.0</td><td style="padding: 2px;">2.3</td></tr></table> cfs	0.0	2.3															
0.0	2.3																		
		Total Design Peak Flow, Q = <table border="1" style="display: inline-table; border-collapse: collapse;"><tr><td style="padding: 2px;">2.4</td><td style="padding: 2px;">8.9</td></tr></table> cfs	2.4	8.9															
2.4	8.9																		

ALLOWABLE CAPACITY FOR ONE-HALF OF STREET (Minor & Major Storm)

(Based on Regulated Criteria for Maximum Allowable Flow Depth and Spread)

Project: **COMPARK SOUTH**

Inlet ID: **INLET 4-5**

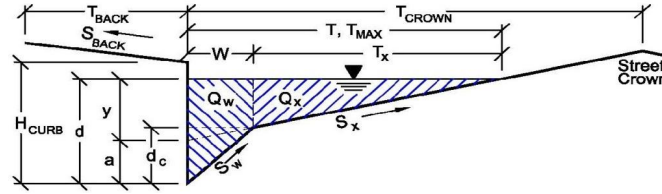

Gutter Geometry (Enter data in the blue cells)									
Maximum Allowable Width for Spread Behind Curb	$T_{BACK} =$ <input style="width: 50px;" type="text" value="0.0"/> ft								
Side Slope Behind Curb (leave blank for no conveyance credit behind curb)	$S_{BACK} =$ <input style="width: 50px;" type="text" value="0.020"/> ft/ft								
Manning's Roughness Behind Curb (typically between 0.012 and 0.020)	$n_{BACK} =$ <input style="width: 50px;" type="text" value="0.020"/>								
Height of Curb at Gutter Flow Line	$H_{CURB} =$ <input style="width: 50px;" type="text" value="4.00"/> inches								
Distance from Curb Face to Street Crown	$T_{CROWN} =$ <input style="width: 50px;" type="text" value="17.0"/> ft								
Gutter Width	$W =$ <input style="width: 50px;" type="text" value="2.00"/> ft								
Street Transverse Slope	$S_x =$ <input style="width: 50px;" type="text" value="0.020"/> ft/ft								
Gutter Cross Slope (typically 2 inches over 24 inches or 0.083 ft/ft)	$S_w =$ <input style="width: 50px;" type="text" value="0.083"/> ft/ft								
Street Longitudinal Slope - Enter 0 for sump condition	$S_o =$ <input style="width: 50px;" type="text" value="0.000"/> ft/ft								
Manning's Roughness for Street Section (typically between 0.012 and 0.020)	$n_{STREET} =$ <input style="width: 50px;" type="text" value="0.016"/>								
Max. Allowable Spread for Minor & Major Storm	<table style="width: 100%; border: none;"> <tr> <td style="width: 30%;"></td> <td style="width: 30%; text-align: center;">Minor Storm</td> <td style="width: 30%; text-align: center;">Major Storm</td> <td style="width: 10%;"></td> </tr> <tr> <td>$T_{MAX} =$</td> <td style="border: 1px solid black; text-align: center;"><input style="width: 40px;" type="text" value="17.0"/></td> <td style="border: 1px solid black; text-align: center;"><input style="width: 40px;" type="text" value="17.0"/></td> <td style="text-align: right;">ft</td> </tr> </table>		Minor Storm	Major Storm		$T_{MAX} =$	<input style="width: 40px;" type="text" value="17.0"/>	<input style="width: 40px;" type="text" value="17.0"/>	ft
	Minor Storm	Major Storm							
$T_{MAX} =$	<input style="width: 40px;" type="text" value="17.0"/>	<input style="width: 40px;" type="text" value="17.0"/>	ft						
Max. Allowable Depth at Gutter Flowline for Minor & Major Storm	<table style="width: 100%; border: none;"> <tr> <td style="width: 30%;"></td> <td style="width: 30%; text-align: center;">Minor Storm</td> <td style="width: 30%; text-align: center;">Major Storm</td> <td style="width: 10%;"></td> </tr> <tr> <td>$d_{MAX} =$</td> <td style="border: 1px solid black; text-align: center;"><input style="width: 40px;" type="text" value="4.0"/></td> <td style="border: 1px solid black; text-align: center;"><input style="width: 40px;" type="text" value="12.0"/></td> <td style="text-align: right;">inches</td> </tr> </table>		Minor Storm	Major Storm		$d_{MAX} =$	<input style="width: 40px;" type="text" value="4.0"/>	<input style="width: 40px;" type="text" value="12.0"/>	inches
	Minor Storm	Major Storm							
$d_{MAX} =$	<input style="width: 40px;" type="text" value="4.0"/>	<input style="width: 40px;" type="text" value="12.0"/>	inches						
Allow Flow Depth at Street Crown (leave blank for no)	<input type="checkbox"/> <input type="checkbox"/> check = yes								
MINOR STORM Allowable Capacity is based on Depth Criterion									
MAJOR STORM Allowable Capacity is based on Depth Criterion									
Minor storm max. allowable capacity GOOD - greater than flow given on sheet 'Q-Peak'									
Major storm max. allowable capacity GOOD - greater than flow given on sheet 'Q-Peak'									
$Q_{allow} =$	<table style="width: 100%; border: none;"> <tr> <td style="width: 30%;"></td> <td style="width: 30%; text-align: center;">Minor Storm</td> <td style="width: 30%; text-align: center;">Major Storm</td> <td style="width: 10%;"></td> </tr> <tr> <td></td> <td style="border: 1px solid black; text-align: center;"><input style="width: 40px;" type="text" value="SUMP"/></td> <td style="border: 1px solid black; text-align: center;"><input style="width: 40px;" type="text" value="SUMP"/></td> <td style="text-align: right;">cfs</td> </tr> </table>		Minor Storm	Major Storm			<input style="width: 40px;" type="text" value="SUMP"/>	<input style="width: 40px;" type="text" value="SUMP"/>	cfs
	Minor Storm	Major Storm							
	<input style="width: 40px;" type="text" value="SUMP"/>	<input style="width: 40px;" type="text" value="SUMP"/>	cfs						

INLET IN A SUMP OR SAG LOCATION

Project = **COMPARK SOUTH**
 Inlet ID = **INLET 4-5**

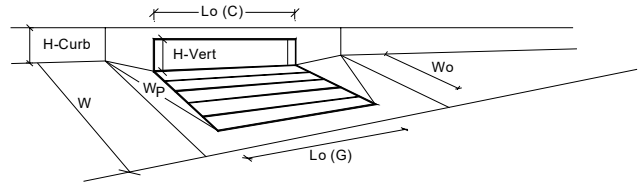

Design Information (Input)	MINOR		MAJOR	
	Type of Inlet	CDOT Type R Curb Opening		
Local Depression (additional to continuous gutter depression 'a' from 'Q-Allow')	a_{local} =	5.00	5.00	inches
Number of Unit Inlets (Grate or Curb Opening)	N_o =	2	2	
Water Depth at Flowline (outside of local depression)	Ponding Depth =	4.0	12.0	inches
Grate Information	<input checked="" type="checkbox"/> Override Depths			
Length of a Unit Grate	$L_o (G)$ =	N/A	N/A	feet
Width of a Unit Grate	W_o =	N/A	N/A	feet
Area Opening Ratio for a Grate (typical values 0.15-0.90)	A_{ratio} =	N/A	N/A	
Clogging Factor for a Single Grate (typical value 0.50 - 0.70)	$C_r (G)$ =	N/A	N/A	
Grate Weir Coefficient (typical value 2.15 - 3.60)	$C_w (G)$ =	N/A	N/A	
Grate Orifice Coefficient (typical value 0.60 - 0.80)	$C_o (G)$ =	N/A	N/A	
Curb Opening Information				
Length of a Unit Curb Opening	$L_o (C)$ =	5.00	5.00	feet
Height of Vertical Curb Opening in Inches	H_{vert} =	6.00	6.00	inches
Height of Curb Orifice Throat in Inches	H_{throat} =	6.00	6.00	inches
Angle of Throat (see USDCM Figure ST-5)	Theta =	63.40	63.40	degrees
Side Width for Depression Pan (typically the gutter width of 2 feet)	W_p =	2.00	2.00	feet
Clogging Factor for a Single Curb Opening (typical value 0.10)	$C_r (C)$ =	0.10	0.10	
Curb Opening Weir Coefficient (typical value 2.3-3.7)	$C_w (C)$ =	3.60	3.60	
Curb Opening Orifice Coefficient (typical value 0.60 - 0.70)	$C_o (C)$ =	0.67	0.67	
Total Inlet Interception Capacity (assumes clogged condition)				
Inlet Capacity IS GOOD for Minor and Major Storms (>Q PEAK)	Q_a =	3.1	27.5	cfs
	$Q_{PEAK REQUIRED}$ =	2.4	8.9	cfs

**DESIGN PEAK FLOW FOR ONE-HALF OF STREET
OR GRASS-LINED CHANNEL BY THE RATIONAL METHOD**

Project: COMPARK SOUTH
 Inlet ID: INLET 4-5A

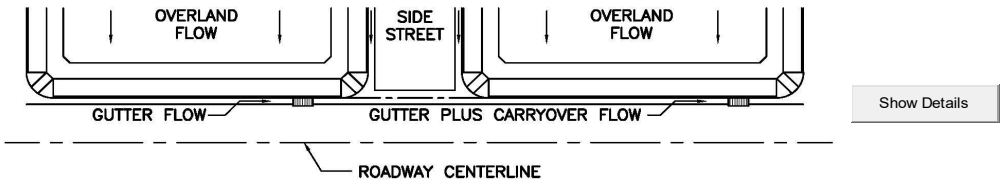

Design Flow: ONLY if already determined through other methods: (local peak flow for 1/2 of street OR grass-lined channel):		Minor Storm Major Storm * Q_{known} = <input type="text" value="4.1"/> <input type="text" value="11.4"/> cfs	<--- FILL IN THIS SECTION OR... FILL IN THE SECTIONS BELOW. <---
Geographic Information: (Enter data in the blue cells): You cannot enter values for Q and use the Q calculator at the same time		Subcatchment Area = <input type="text"/> Acres Percent Imperviousness = <input type="text"/> % NRCS Soil Type = <input type="text"/> A, B, C, or D	
Site Type: <input type="radio"/> Site is Urban <input type="radio"/> Site is Non-Urban	Flows Developed For: <input checked="" type="radio"/> Street Inlets <input type="radio"/> Area Inlets in a Median	Slope (ft/ft) Length (ft) Overland Flow = <input type="text"/> <input type="text"/> Gutter Flow = <input type="text"/> <input type="text"/>	
Rainfall Information: Intensity I (inch/hr) = $C_1 * P_1 / (C_2 + T_c)^{C_3}$		Minor Storm Major Storm	
Design Storm Return Period, T_r = <input type="text"/> years Return Period One-Hour Precipitation, P_1 = <input type="text"/> inches C_1 = <input type="text"/> C_2 = <input type="text"/> C_3 = <input type="text"/> User-Defined Storm Runoff Coefficient (leave this blank to accept a calculated value), C = <input type="text"/> User-Defined 5-yr. Runoff Coefficient (leave this blank to accept a calculated value), C_5 = <input type="text"/>		Bypass (Carry-Over) Flow from upstream Subcatchments, Q_b = <input type="text" value="0.0"/> <input type="text" value="0.2"/> cfs	
Total Design Peak Flow, Q = <input type="text" value="4.1"/> <input type="text" value="11.6"/> cfs			

ALLOWABLE CAPACITY FOR ONE-HALF OF STREET (Minor & Major Storm)

(Based on Regulated Criteria for Maximum Allowable Flow Depth and Spread)

Project: **COMPARK SOUTH**
 Inlet ID: **INLET 4-5A**

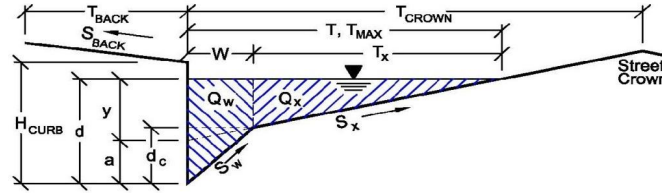

Gutter Geometry (Enter data in the blue cells)													
Maximum Allowable Width for Spread Behind Curb	$T_{BACK} = 0.0$ ft												
Side Slope Behind Curb (leave blank for no conveyance credit behind curb)	$S_{BACK} = 0.020$ ft/ft												
Manning's Roughness Behind Curb (typically between 0.012 and 0.020)	$n_{BACK} = 0.020$												
Height of Curb at Gutter Flow Line	$H_{CURB} = 4.00$ inches												
Distance from Curb Face to Street Crown	$T_{CROWN} = 17.0$ ft												
Gutter Width	$W = 2.00$ ft												
Street Transverse Slope	$S_x = 0.020$ ft/ft												
Gutter Cross Slope (typically 2 inches over 24 inches or 0.083 ft/ft)	$S_w = 0.083$ ft/ft												
Street Longitudinal Slope - Enter 0 for sump condition	$S_o = 0.010$ ft/ft												
Manning's Roughness for Street Section (typically between 0.012 and 0.020)	$n_{STREET} = 0.016$												
Max. Allowable Spread for Minor & Major Storm	<table border="1" style="display: inline-table; border-collapse: collapse;"> <thead> <tr> <th></th> <th>Minor Storm</th> <th>Major Storm</th> <th></th> </tr> </thead> <tbody> <tr> <td>$T_{MAX} =$</td> <td>17.0</td> <td>17.0</td> <td>ft</td> </tr> <tr> <td>$d_{MAX} =$</td> <td>4.3</td> <td>12.0</td> <td>inches</td> </tr> </tbody> </table>		Minor Storm	Major Storm		$T_{MAX} =$	17.0	17.0	ft	$d_{MAX} =$	4.3	12.0	inches
	Minor Storm	Major Storm											
$T_{MAX} =$	17.0	17.0	ft										
$d_{MAX} =$	4.3	12.0	inches										
Max. Allowable Depth at Gutter Flowline for Minor & Major Storm													
Allow Flow Depth at Street Crown (leave blank for no)	<input type="checkbox"/> <input checked="" type="checkbox"/> check = yes												
MINOR STORM Allowable Capacity is based on Depth Criterion													
MAJOR STORM Allowable Capacity is based on Depth Criterion													
Minor storm max. allowable capacity GOOD - greater than flow given on sheet 'Q-Peak' Major storm max. allowable capacity GOOD - greater than flow given on sheet 'Q-Peak'	<table border="1" style="display: inline-table; border-collapse: collapse;"> <thead> <tr> <th></th> <th>Minor Storm</th> <th>Major Storm</th> <th></th> </tr> </thead> <tbody> <tr> <td>$Q_{allow} =$</td> <td>4.4</td> <td>91.2</td> <td>cfs</td> </tr> </tbody> </table>		Minor Storm	Major Storm		$Q_{allow} =$	4.4	91.2	cfs				
	Minor Storm	Major Storm											
$Q_{allow} =$	4.4	91.2	cfs										

INLET ON A CONTINUOUS GRADE

Project: COMPARK SOUTH
 Inlet ID: INLET 4-5A

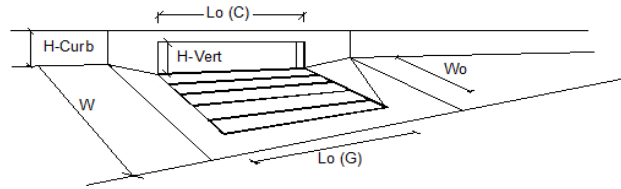

Design Information (Input)	MINOR		MAJOR	
	Type of Inlet	Type = CDOT Type R Curb Opening		
Local Depression (additional to continuous gutter depression 'a' from 'Q-Allow')	a _{LOCAL} = 3.0	3.0	inches	
Total Number of Units in the Inlet (Grate or Curb Opening)	No = 3	3		
Length of a Single Unit Inlet (Grate or Curb Opening)	L _o = 5.00	5.00	ft	
Width of a Unit Grate (cannot be greater than W from Q-Allow)	W _o = N/A	N/A	ft	
Clogging Factor for a Single Unit Grate (typical min. value = 0.5)	C _{r-G} = N/A	N/A		
Clogging Factor for a Single Unit Curb Opening (typical min. value = 0.1)	C _{r-C} = 0.10	0.10		
Street Hydraulics: OK - Q < maximum allowable from sheet 'Q-Allow'				
Total Inlet Interception Capacity	Q = 4.10	10.24	cfs	
Total Inlet Carry-Over Flow (flow bypassing inlet)	Q _b = 0.0	1.4	cfs	
Capture Percentage = Q _a /Q _o =	C% = 100	88	%	

**DESIGN PEAK FLOW FOR ONE-HALF OF STREET
OR GRASS-LINED CHANNEL BY THE RATIONAL METHOD**

Project: COMPARK SOUTH
 Inlet ID: INLET 4-5B

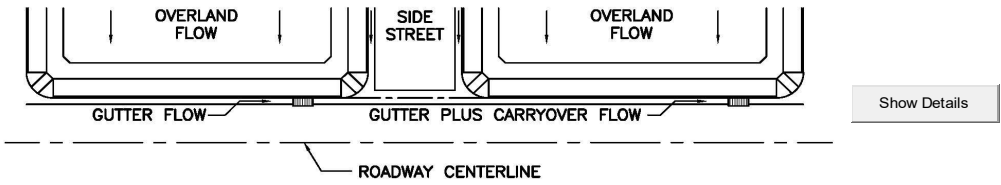

Design Flow: ONLY if already determined through other methods: (local peak flow for 1/2 of street OR grass-lined channel):		Minor Storm Major Storm * Q_{known} = <input type="text" value="3.4"/> <input type="text" value="8.5"/> cfs	<--- FILL IN THIS SECTION OR... FILL IN THE SECTIONS BELOW. <---
Geographic Information: (Enter data in the blue cells):		Subcatchment Area = <input type="text"/> Acres Percent Imperviousness = <input type="text"/> % NRCS Soil Type = <input type="text"/> A, B, C, or D	
Site Type: <input type="radio"/> Site is Urban <input type="radio"/> Site is Non-Urban	Flows Developed For: <input type="radio"/> Street Inlets <input type="radio"/> Area Inlets in a Median	Slope (ft/ft) Length (ft) Overland Flow = <input type="text"/> <input type="text"/> Channel Flow = <input type="text"/> <input type="text"/>	
Rainfall Information: Intensity I (inch/hr) = $C_1 * P_1 / (C_2 + T_c)^{C_3}$		Minor Storm Major Storm	
		Design Storm Return Period, T_r = <input type="text"/> years	
		Return Period One-Hour Precipitation, P_1 = <input type="text"/> inches	
		C_1 = <input type="text"/>	
		C_2 = <input type="text"/>	
		C_3 = <input type="text"/>	
User-Defined Storm Runoff Coefficient (leave this blank to accept a calculated value), C = <input type="text"/>		C = <input type="text"/>	
User-Defined 5-yr. Runoff Coefficient (leave this blank to accept a calculated value), C_5 = <input type="text"/>		C_5 = <input type="text"/>	
		Bypass (Carry-Over) Flow from upstream Subcatchments, Q_b = <input type="text" value="0.0"/> <input type="text" value="0.9"/> cfs	
		Total Design Peak Flow, Q = <input type="text" value="3.4"/> <input type="text" value="9.4"/> cfs	

ALLOWABLE CAPACITY FOR ONE-HALF OF STREET (Minor & Major Storm)

(Based on Regulated Criteria for Maximum Allowable Flow Depth and Spread)

Project: **COMPARK SOUTH**
 Inlet ID: **INLET 4-5B**

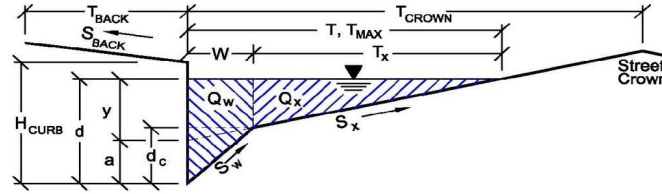

Gutter Geometry (Enter data in the blue cells)													
Maximum Allowable Width for Spread Behind Curb	$T_{BACK} = 0.0$ ft												
Side Slope Behind Curb (leave blank for no conveyance credit behind curb)	$S_{BACK} = 0.020$ ft/ft												
Manning's Roughness Behind Curb (typically between 0.012 and 0.020)	$n_{BACK} = 0.020$												
Height of Curb at Gutter Flow Line	$H_{CURB} = 4.00$ inches												
Distance from Curb Face to Street Crown	$T_{CROWN} = 17.0$ ft												
Gutter Width	$W = 2.00$ ft												
Street Transverse Slope	$S_x = 0.020$ ft/ft												
Gutter Cross Slope (typically 2 inches over 24 inches or 0.083 ft/ft)	$S_w = 0.083$ ft/ft												
Street Longitudinal Slope - Enter 0 for sump condition	$S_o = 0.010$ ft/ft												
Manning's Roughness for Street Section (typically between 0.012 and 0.020)	$n_{STREET} = 0.016$												
Max. Allowable Spread for Minor & Major Storm	<table border="1" style="display: inline-table; border-collapse: collapse;"> <thead> <tr> <th></th> <th>Minor Storm</th> <th>Major Storm</th> <th></th> </tr> </thead> <tbody> <tr> <td>$T_{MAX} =$</td> <td>17.0</td> <td>17.0</td> <td>ft</td> </tr> <tr> <td>$d_{MAX} =$</td> <td>4.0</td> <td>12.0</td> <td>inches</td> </tr> </tbody> </table>		Minor Storm	Major Storm		$T_{MAX} =$	17.0	17.0	ft	$d_{MAX} =$	4.0	12.0	inches
	Minor Storm	Major Storm											
$T_{MAX} =$	17.0	17.0	ft										
$d_{MAX} =$	4.0	12.0	inches										
Max. Allowable Depth at Gutter Flowline for Minor & Major Storm													
Allow Flow Depth at Street Crown (leave blank for no)	<input type="checkbox"/> <input checked="" type="checkbox"/> check = yes												
MINOR STORM Allowable Capacity is based on Depth Criterion													
MAJOR STORM Allowable Capacity is based on Depth Criterion													
Minor storm max. allowable capacity GOOD - greater than flow given on sheet 'Q-Peak'													
Major storm max. allowable capacity GOOD - greater than flow given on sheet 'Q-Peak'													
	<table border="1" style="display: inline-table; border-collapse: collapse;"> <thead> <tr> <th></th> <th>Minor Storm</th> <th>Major Storm</th> <th></th> </tr> </thead> <tbody> <tr> <td>$Q_{allow} =$</td> <td>3.4</td> <td>91.2</td> <td>cfs</td> </tr> </tbody> </table>		Minor Storm	Major Storm		$Q_{allow} =$	3.4	91.2	cfs				
	Minor Storm	Major Storm											
$Q_{allow} =$	3.4	91.2	cfs										

INLET ON A CONTINUOUS GRADE

Project: COMPARK SOUTH
 Inlet ID: INLET 4-5B

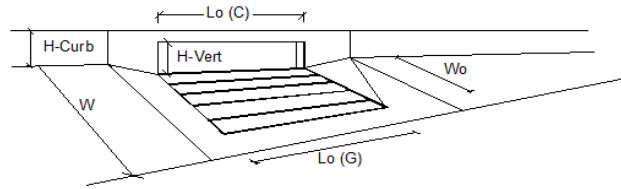

Design Information (Input)	MINOR		MAJOR		
	MINOR	MAJOR	MINOR	MAJOR	
Type of Inlet	CDOT Type R Curb Opening				
Local Depression (additional to continuous gutter depression 'a' from 'Q-Allow')	3.0	3.0			inches
Total Number of Units in the Inlet (Grate or Curb Opening)	2	2			
Length of a Single Unit Inlet (Grate or Curb Opening)	5.00	5.00			ft
Width of a Unit Grate (cannot be greater than W from Q-Allow)	N/A	N/A			ft
Clogging Factor for a Single Unit Grate (typical min. value = 0.5)	N/A	N/A			
Clogging Factor for a Single Unit Curb Opening (typical min. value = 0.1)	0.10	0.10			
Street Hydraulics: OK - Q < maximum allowable from sheet 'Q-Allow'					
Total Inlet Interception Capacity	3.40	6.90			cfs
Total Inlet Carry-Over Flow (flow bypassing inlet)	0.0	2.4			cfs
Capture Percentage = Q_a/Q_o =	100	74			%

**DESIGN PEAK FLOW FOR ONE-HALF OF STREET
OR GRASS-LINED CHANNEL BY THE RATIONAL METHOD**

Project: COMPARK SOUTH
 Inlet ID: INLET 4-5C

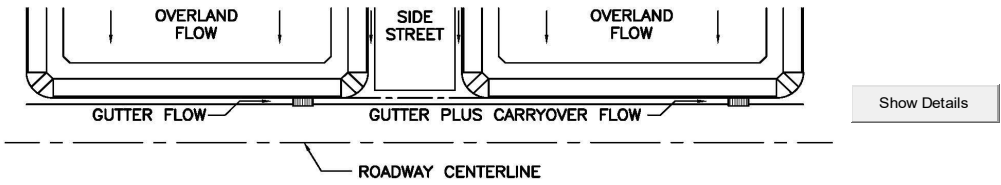

Design Flow: ONLY if already determined through other methods: (local peak flow for 1/2 of street OR grass-lined channel):		Minor Storm Major Storm *Q _{known} = <input type="text" value="2.4"/> <input type="text" value="6.7"/> cfs	<--- FILL IN THIS SECTION OR... FILL IN THE SECTIONS BELOW. <---
Geographic Information: (Enter data in the blue cells):		Subcatchment Area = <input type="text"/> Acres Percent Imperviousness = <input type="text"/> % NRCS Soil Type = <input type="text"/> A, B, C, or D	
Site Type: <input type="radio"/> Site is Urban <input type="radio"/> Site is Non-Urban	Flows Developed For: <input type="radio"/> Street Inlets <input type="radio"/> Area Inlets in a Median	Slope (ft/ft) Length (ft) Overland Flow = <input type="text"/> <input type="text"/> Channel Flow = <input type="text"/> <input type="text"/>	
Rainfall Information: Intensity I (inch/hr) = $C_1 * P_1 / (C_2 + T_c)^{C_3}$		Minor Storm Major Storm	
Design Storm Return Period, T _r = <input type="text"/> years Return Period One-Hour Precipitation, P ₁ = <input type="text"/> inches C ₁ = <input type="text"/> C ₂ = <input type="text"/> C ₃ = <input type="text"/> User-Defined Storm Runoff Coefficient (leave this blank to accept a calculated value), C = <input type="text"/> User-Defined 5-yr. Runoff Coefficient (leave this blank to accept a calculated value), C ₅ = <input type="text"/>		Bypass (Carry-Over) Flow from upstream Subcatchments, Q _b = <input type="text" value="0.0"/> <input type="text" value="1.2"/> cfs	
Total Design Peak Flow, Q = <input type="text" value="2.4"/> <input type="text" value="7.9"/> cfs			

ALLOWABLE CAPACITY FOR ONE-HALF OF STREET (Minor & Major Storm)

(Based on Regulated Criteria for Maximum Allowable Flow Depth and Spread)

Project: **COMPARK SOUTH**
 Inlet ID: **INLET 4-5C**

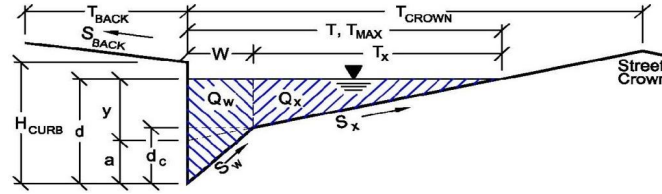

Gutter Geometry (Enter data in the blue cells)																	
Maximum Allowable Width for Spread Behind Curb	$T_{BACK} = $ <input style="width: 50px;" type="text" value="0.0"/> ft																
Side Slope Behind Curb (leave blank for no conveyance credit behind curb)	$S_{BACK} = $ <input style="width: 50px;" type="text" value="0.020"/> ft/ft																
Manning's Roughness Behind Curb (typically between 0.012 and 0.020)	$n_{BACK} = $ <input style="width: 50px;" type="text" value="0.020"/>																
Height of Curb at Gutter Flow Line	$H_{CURB} = $ <input style="width: 50px;" type="text" value="4.00"/> inches																
Distance from Curb Face to Street Crown	$T_{CROWN} = $ <input style="width: 50px;" type="text" value="17.0"/> ft																
Gutter Width	$W = $ <input style="width: 50px;" type="text" value="2.00"/> ft																
Street Transverse Slope	$S_x = $ <input style="width: 50px;" type="text" value="0.020"/> ft/ft																
Gutter Cross Slope (typically 2 inches over 24 inches or 0.083 ft/ft)	$S_w = $ <input style="width: 50px;" type="text" value="0.083"/> ft/ft																
Street Longitudinal Slope - Enter 0 for sump condition	$S_o = $ <input style="width: 50px;" type="text" value="0.010"/> ft/ft																
Manning's Roughness for Street Section (typically between 0.012 and 0.020)	$n_{STREET} = $ <input style="width: 50px;" type="text" value="0.016"/>																
Max. Allowable Spread for Minor & Major Storm	<table style="width: 100%; border-collapse: collapse;"> <thead> <tr> <th style="width: 50%;"></th> <th style="width: 25%; text-align: center;">Minor Storm</th> <th style="width: 25%; text-align: center;">Major Storm</th> <th style="width: 10%;"></th> </tr> </thead> <tbody> <tr> <td>$T_{MAX} =$</td> <td style="text-align: center;"><input style="width: 40px;" type="text" value="17.0"/></td> <td style="text-align: center;"><input style="width: 40px;" type="text" value="17.0"/></td> <td style="text-align: right;">ft</td> </tr> <tr> <td>$d_{MAX} =$</td> <td style="text-align: center;"><input style="width: 40px;" type="text" value="4.0"/></td> <td style="text-align: center;"><input style="width: 40px;" type="text" value="12.0"/></td> <td style="text-align: right;">inches</td> </tr> <tr> <td></td> <td style="text-align: center;"><input type="checkbox"/></td> <td style="text-align: center;"><input checked="" type="checkbox"/></td> <td style="text-align: right;">check = yes</td> </tr> </tbody> </table>		Minor Storm	Major Storm		$T_{MAX} = $	<input style="width: 40px;" type="text" value="17.0"/>	<input style="width: 40px;" type="text" value="17.0"/>	ft	$d_{MAX} = $	<input style="width: 40px;" type="text" value="4.0"/>	<input style="width: 40px;" type="text" value="12.0"/>	inches		<input type="checkbox"/>	<input checked="" type="checkbox"/>	check = yes
	Minor Storm	Major Storm															
$T_{MAX} = $	<input style="width: 40px;" type="text" value="17.0"/>	<input style="width: 40px;" type="text" value="17.0"/>	ft														
$d_{MAX} = $	<input style="width: 40px;" type="text" value="4.0"/>	<input style="width: 40px;" type="text" value="12.0"/>	inches														
	<input type="checkbox"/>	<input checked="" type="checkbox"/>	check = yes														
Max. Allowable Depth at Gutter Flowline for Minor & Major Storm	$d_{MAX} = $ <input style="width: 50px;" type="text" value="4.0"/> inches																
Allow Flow Depth at Street Crown (leave blank for no)	<input type="checkbox"/> <input checked="" type="checkbox"/> check = yes																
MINOR STORM Allowable Capacity is based on Depth Criterion																	
MAJOR STORM Allowable Capacity is based on Depth Criterion																	
Minor storm max. allowable capacity GOOD - greater than flow given on sheet 'Q-Peak'																	
Major storm max. allowable capacity GOOD - greater than flow given on sheet 'Q-Peak'																	
$Q_{allow} = $	<table style="width: 100%; border-collapse: collapse;"> <thead> <tr> <th style="width: 50%;"></th> <th style="width: 25%; text-align: center;">Minor Storm</th> <th style="width: 25%; text-align: center;">Major Storm</th> <th style="width: 10%;"></th> </tr> </thead> <tbody> <tr> <td></td> <td style="text-align: center;"><input style="width: 40px;" type="text" value="3.4"/></td> <td style="text-align: center;"><input style="width: 40px;" type="text" value="91.2"/></td> <td style="text-align: right;">cfs</td> </tr> </tbody> </table>		Minor Storm	Major Storm			<input style="width: 40px;" type="text" value="3.4"/>	<input style="width: 40px;" type="text" value="91.2"/>	cfs								
	Minor Storm	Major Storm															
	<input style="width: 40px;" type="text" value="3.4"/>	<input style="width: 40px;" type="text" value="91.2"/>	cfs														

INLET ON A CONTINUOUS GRADE

Project: COMPARK SOUTH
 Inlet ID: INLET 4-5C

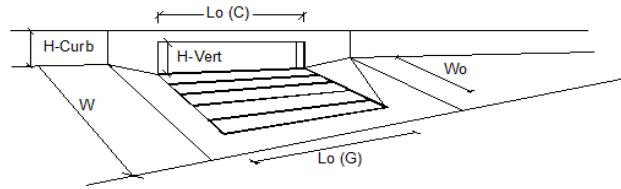

Design Information (Input)	MINOR		MAJOR	
	Type of Inlet	Type = CDOT Type R Curb Opening		
Local Depression (additional to continuous gutter depression 'a' from 'Q-Allow')	a _{LOCAL} = 5.0	5.0	inches	
Total Number of Units in the Inlet (Grate or Curb Opening)	No = 2	2		
Length of a Single Unit Inlet (Grate or Curb Opening)	L _o = 5.00	5.00	ft	
Width of a Unit Grate (cannot be greater than W from Q-Allow)	W _o = N/A	N/A	ft	
Clogging Factor for a Single Unit Grate (typical min. value = 0.5)	C _{r-G} = N/A	N/A		
Clogging Factor for a Single Unit Curb Opening (typical min. value = 0.1)	C _{r-C} = 0.10	0.10		
Street Hydraulics: OK - Q < maximum allowable from sheet 'Q-Allow'				
Total Inlet Interception Capacity	Q = 2.40	6.85	cfs	
Total Inlet Carry-Over Flow (flow bypassing inlet)	Q _b = 0.0	1.1	cfs	
Capture Percentage = Q _a /Q _o =	C% = 100	87	%	

**DESIGN PEAK FLOW FOR ONE-HALF OF STREET
OR GRASS-LINED CHANNEL BY THE RATIONAL METHOD**

Project: COMPARK SOUTH
 Inlet ID: INLET 5-4

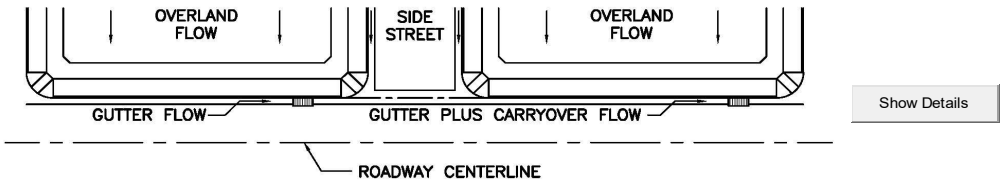

Design Flow: ONLY if already determined through other methods: (local peak flow for 1/2 of street OR grass-lined channel):		<table border="1" style="display: inline-table;"> <tr> <td>Minor Storm</td> <td>Major Storm</td> </tr> <tr> <td align="center">3.4</td> <td align="center">10.8</td> </tr> </table> cfs	Minor Storm	Major Storm	3.4	10.8	<--- FILL IN THIS SECTION OR... FILL IN THE SECTIONS BELOW. <---
Minor Storm	Major Storm						
3.4	10.8						
* If you enter values in Row 14, skip the rest of this sheet and proceed to sheet Q-Allow or Area Inlet.							
Geographic Information: (Enter data in the blue cells):							
Site Type: <input type="radio"/> Site is Urban <input type="radio"/> Site is Non-Urban	Flows Developed For: <input type="radio"/> Street Inlets <input type="radio"/> Area Inlets in a Median	Subcatchment Area = <input type="text"/> Acres Percent Imperviousness = <input type="text"/> % NRCS Soil Type = <input type="text"/> A, B, C, or D					
		Slope (ft/ft) Length (ft) Overland Flow = <input type="text"/> <input type="text"/> Channel Flow = <input type="text"/> <input type="text"/>					
Rainfall Information: Intensity I (inch/hr) = $C_1 * P_1 / (C_2 + T_c)^{C_3}$		<table border="1" style="display: inline-table;"> <tr> <td>Minor Storm</td> <td>Major Storm</td> </tr> <tr> <td></td> <td></td> </tr> </table> years	Minor Storm	Major Storm			
Minor Storm	Major Storm						
		Design Storm Return Period, T_r = <input type="text"/>					
		Return Period One-Hour Precipitation, P_1 = <input type="text"/> inches					
		C_1 = <input type="text"/>					
		C_2 = <input type="text"/>					
		C_3 = <input type="text"/>					
User-Defined Storm Runoff Coefficient (leave this blank to accept a calculated value), C = <input type="text"/>							
User-Defined 5-yr. Runoff Coefficient (leave this blank to accept a calculated value), C_5 = <input type="text"/>							
Bypass (Carry-Over) Flow from upstream Subcatchments, Q_b = <input type="text"/>		<table border="1" style="display: inline-table;"> <tr> <td>0.0</td> <td>0.0</td> </tr> </table> cfs	0.0	0.0			
0.0	0.0						
Total Design Peak Flow, Q = <input type="text"/>		<table border="1" style="display: inline-table;"> <tr> <td>3.4</td> <td>10.8</td> </tr> </table> cfs	3.4	10.8			
3.4	10.8						

ALLOWABLE CAPACITY FOR ONE-HALF OF STREET (Minor & Major Storm)

(Based on Regulated Criteria for Maximum Allowable Flow Depth and Spread)

Project: **COMPARK SOUTH**

Inlet ID: **INLET 5-4**

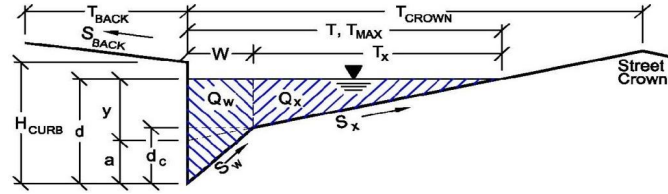

Gutter Geometry (Enter data in the blue cells)							
Maximum Allowable Width for Spread Behind Curb	$T_{BACK} = 0.0$ ft						
Side Slope Behind Curb (leave blank for no conveyance credit behind curb)	$S_{BACK} = 0.020$ ft/ft						
Manning's Roughness Behind Curb (typically between 0.012 and 0.020)	$n_{BACK} = 0.020$						
Height of Curb at Gutter Flow Line	$H_{CURB} = 4.00$ inches						
Distance from Curb Face to Street Crown	$T_{CROWN} = 17.0$ ft						
Gutter Width	$W = 2.00$ ft						
Street Transverse Slope	$S_x = 0.020$ ft/ft						
Gutter Cross Slope (typically 2 inches over 24 inches or 0.083 ft/ft)	$S_w = 0.083$ ft/ft						
Street Longitudinal Slope - Enter 0 for sump condition	$S_o = 0.010$ ft/ft						
Manning's Roughness for Street Section (typically between 0.012 and 0.020)	$n_{STREET} = 0.016$						
Max. Allowable Spread for Minor & Major Storm	<table border="1" style="display: inline-table; border-collapse: collapse;"> <thead> <tr> <th style="text-align: center;">Minor Storm</th> <th style="text-align: center;">Major Storm</th> <th></th> </tr> </thead> <tbody> <tr> <td style="text-align: center;">$T_{MAX} = 17.0$</td> <td style="text-align: center;">$T_{MAX} = 17.0$</td> <td style="text-align: right;">ft</td> </tr> </tbody> </table>	Minor Storm	Major Storm		$T_{MAX} = 17.0$	$T_{MAX} = 17.0$	ft
Minor Storm	Major Storm						
$T_{MAX} = 17.0$	$T_{MAX} = 17.0$	ft					
Max. Allowable Depth at Gutter Flowline for Minor & Major Storm	<table border="1" style="display: inline-table; border-collapse: collapse;"> <thead> <tr> <th style="text-align: center;">Minor Storm</th> <th style="text-align: center;">Major Storm</th> <th></th> </tr> </thead> <tbody> <tr> <td style="text-align: center;">$d_{MAX} = 4.0$</td> <td style="text-align: center;">$d_{MAX} = 12.0$</td> <td style="text-align: right;">inches</td> </tr> </tbody> </table>	Minor Storm	Major Storm		$d_{MAX} = 4.0$	$d_{MAX} = 12.0$	inches
Minor Storm	Major Storm						
$d_{MAX} = 4.0$	$d_{MAX} = 12.0$	inches					
Allow Flow Depth at Street Crown (leave blank for no)	<input type="checkbox"/> <input checked="" type="checkbox"/> check = yes						
MINOR STORM Allowable Capacity is based on Depth Criterion							
MAJOR STORM Allowable Capacity is based on Depth Criterion							
Minor storm max. allowable capacity GOOD - greater than flow given on sheet 'Q-Peak'							
Major storm max. allowable capacity GOOD - greater than flow given on sheet 'Q-Peak'							
$Q_{allow} =$	<table border="1" style="display: inline-table; border-collapse: collapse;"> <thead> <tr> <th style="text-align: center;">Minor Storm</th> <th style="text-align: center;">Major Storm</th> <th></th> </tr> </thead> <tbody> <tr> <td style="text-align: center;">3.4</td> <td style="text-align: center;">91.4</td> <td style="text-align: right;">cfs</td> </tr> </tbody> </table>	Minor Storm	Major Storm		3.4	91.4	cfs
Minor Storm	Major Storm						
3.4	91.4	cfs					

INLET ON A CONTINUOUS GRADE

Project: COMPARK SOUTH
 Inlet ID: INLET 5-4

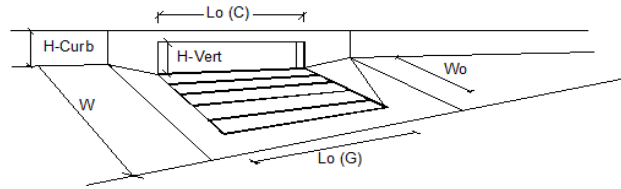

Design Information (Input)	MINOR		MAJOR		
	MINOR	MAJOR	MINOR	MAJOR	
Type of Inlet	CDOT Type R Curb Opening				
Local Depression (additional to continuous gutter depression 'a' from 'Q-Allow')	3.0	3.0			inches
Total Number of Units in the Inlet (Grate or Curb Opening)	3	3			
Length of a Single Unit Inlet (Grate or Curb Opening)	5.00	5.00			ft
Width of a Unit Grate (cannot be greater than W from Q-Allow)	N/A	N/A			ft
Clogging Factor for a Single Unit Grate (typical min. value = 0.5)	N/A	N/A			
Clogging Factor for a Single Unit Curb Opening (typical min. value = 0.1)	0.10	0.10			
Street Hydraulics: OK - Q < maximum allowable from sheet 'Q-Allow'					
Total Inlet Interception Capacity	3.40	9.77			cfs
Total Inlet Carry-Over Flow (flow bypassing inlet)	0.0	1.0			cfs
Capture Percentage = Q_a/Q_o =	100	90			%

**DESIGN PEAK FLOW FOR ONE-HALF OF STREET
OR GRASS-LINED CHANNEL BY THE RATIONAL METHOD**

Project: COMPARK SOUTH
 Inlet ID: INLET 5-4A

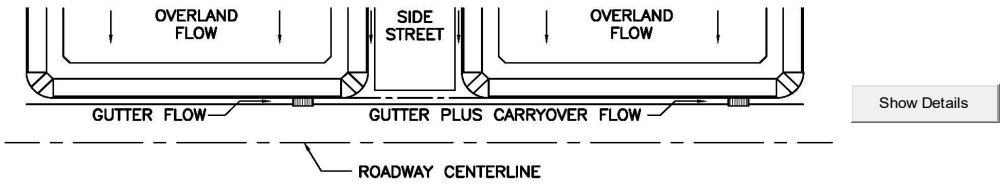

Design Flow: ONLY if already determined through other methods: (local peak flow for 1/2 of street OR grass-lined channel):		<table border="1" style="display: inline-table; border-collapse: collapse;"> <tr> <td style="padding: 2px;">Minor Storm</td> <td style="padding: 2px;">Major Storm</td> </tr> <tr> <td style="text-align: center; padding: 2px;">1.0</td> <td style="text-align: center; padding: 2px;">2.6</td> </tr> </table> cfs	Minor Storm	Major Storm	1.0	2.6	<--- FILL IN THIS SECTION OR... FILL IN THE SECTIONS BELOW. <---												
Minor Storm	Major Storm																		
1.0	2.6																		
* If you enter values in Row 14, skip the rest of this sheet and proceed to sheet Q-Allow or Area Inlet.																			
Geographic Information: (Enter data in the blue cells):																			
Site Type: <input type="radio"/> Site is Urban <input type="radio"/> Site is Non-Urban	Flows Developed For: <input type="radio"/> Street Inlets <input type="radio"/> Area Inlets in a Median	Subcatchment Area = <input style="width: 50px;" type="text"/> Acres Percent Imperviousness = <input style="width: 50px;" type="text"/> % NRCS Soil Type = <input style="width: 50px;" type="text"/> A, B, C, or D																	
		<table border="1" style="display: inline-table; border-collapse: collapse;"> <tr> <td style="padding: 2px;">Slope (ft/ft)</td> <td style="padding: 2px;">Length (ft)</td> </tr> <tr> <td style="padding: 2px;">Overland Flow = <input style="width: 50px;" type="text"/></td> <td style="padding: 2px;">Channel Flow = <input style="width: 50px;" type="text"/></td> </tr> </table>	Slope (ft/ft)	Length (ft)	Overland Flow = <input style="width: 50px;" type="text"/>	Channel Flow = <input style="width: 50px;" type="text"/>													
Slope (ft/ft)	Length (ft)																		
Overland Flow = <input style="width: 50px;" type="text"/>	Channel Flow = <input style="width: 50px;" type="text"/>																		
Rainfall Information: Intensity I (inch/hr) = $C_1 * P_1 / (C_2 + T_c)^{C_3}$		<table border="1" style="display: inline-table; border-collapse: collapse;"> <tr> <td style="padding: 2px;">Minor Storm</td> <td style="padding: 2px;">Major Storm</td> </tr> <tr> <td style="padding: 2px;">Design Storm Return Period, T_r = <input style="width: 50px;" type="text"/></td> <td style="padding: 2px;">years</td> </tr> <tr> <td style="padding: 2px;">Return Period One-Hour Precipitation, P_1 = <input style="width: 50px;" type="text"/></td> <td style="padding: 2px;">inches</td> </tr> <tr> <td style="padding: 2px;">C_1 = <input style="width: 50px;" type="text"/></td> <td></td> </tr> <tr> <td style="padding: 2px;">C_2 = <input style="width: 50px;" type="text"/></td> <td></td> </tr> <tr> <td style="padding: 2px;">C_3 = <input style="width: 50px;" type="text"/></td> <td></td> </tr> <tr> <td style="padding: 2px;">User-Defined Storm Runoff Coefficient (leave this blank to accept a calculated value), C = <input style="width: 50px;" type="text"/></td> <td></td> </tr> <tr> <td style="padding: 2px;">User-Defined 5-yr. Runoff Coefficient (leave this blank to accept a calculated value), C_5 = <input style="width: 50px;" type="text"/></td> <td></td> </tr> </table>	Minor Storm	Major Storm	Design Storm Return Period, T_r = <input style="width: 50px;" type="text"/>	years	Return Period One-Hour Precipitation, P_1 = <input style="width: 50px;" type="text"/>	inches	C_1 = <input style="width: 50px;" type="text"/>		C_2 = <input style="width: 50px;" type="text"/>		C_3 = <input style="width: 50px;" type="text"/>		User-Defined Storm Runoff Coefficient (leave this blank to accept a calculated value), C = <input style="width: 50px;" type="text"/>		User-Defined 5-yr. Runoff Coefficient (leave this blank to accept a calculated value), C_5 = <input style="width: 50px;" type="text"/>		
Minor Storm	Major Storm																		
Design Storm Return Period, T_r = <input style="width: 50px;" type="text"/>	years																		
Return Period One-Hour Precipitation, P_1 = <input style="width: 50px;" type="text"/>	inches																		
C_1 = <input style="width: 50px;" type="text"/>																			
C_2 = <input style="width: 50px;" type="text"/>																			
C_3 = <input style="width: 50px;" type="text"/>																			
User-Defined Storm Runoff Coefficient (leave this blank to accept a calculated value), C = <input style="width: 50px;" type="text"/>																			
User-Defined 5-yr. Runoff Coefficient (leave this blank to accept a calculated value), C_5 = <input style="width: 50px;" type="text"/>																			
		Bypass (Carry-Over) Flow from upstream Subcatchments, Q_b = <table border="1" style="display: inline-table; border-collapse: collapse;"> <tr> <td style="padding: 2px;">0.0</td> <td style="padding: 2px;">0.0</td> </tr> </table> cfs	0.0	0.0															
0.0	0.0																		
		Total Design Peak Flow, Q = <table border="1" style="display: inline-table; border-collapse: collapse;"> <tr> <td style="padding: 2px;">1.0</td> <td style="padding: 2px;">2.6</td> </tr> </table> cfs	1.0	2.6															
1.0	2.6																		

ALLOWABLE CAPACITY FOR ONE-HALF OF STREET (Minor & Major Storm)

(Based on Regulated Criteria for Maximum Allowable Flow Depth and Spread)

Project: **COMPARK SOUTH**
 Inlet ID: **INLET 5-4A**

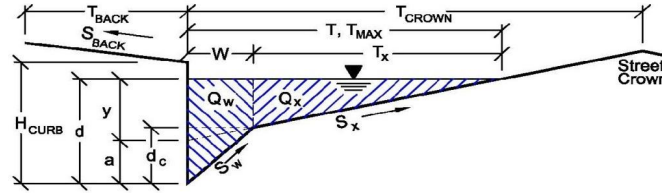

Gutter Geometry (Enter data in the blue cells)									
Maximum Allowable Width for Spread Behind Curb	$T_{BACK} = $ <input style="width: 50px;" type="text" value="0.0"/> ft								
Side Slope Behind Curb (leave blank for no conveyance credit behind curb)	$S_{BACK} = $ <input style="width: 50px;" type="text" value="0.020"/> ft/ft								
Manning's Roughness Behind Curb (typically between 0.012 and 0.020)	$n_{BACK} = $ <input style="width: 50px;" type="text" value="0.020"/>								
Height of Curb at Gutter Flow Line	$H_{CURB} = $ <input style="width: 50px;" type="text" value="4.00"/> inches								
Distance from Curb Face to Street Crown	$T_{CROWN} = $ <input style="width: 50px;" type="text" value="17.0"/> ft								
Gutter Width	$W = $ <input style="width: 50px;" type="text" value="2.00"/> ft								
Street Transverse Slope	$S_x = $ <input style="width: 50px;" type="text" value="0.020"/> ft/ft								
Gutter Cross Slope (typically 2 inches over 24 inches or 0.083 ft/ft)	$S_w = $ <input style="width: 50px;" type="text" value="0.083"/> ft/ft								
Street Longitudinal Slope - Enter 0 for sump condition	$S_o = $ <input style="width: 50px;" type="text" value="0.010"/> ft/ft								
Manning's Roughness for Street Section (typically between 0.012 and 0.020)	$n_{STREET} = $ <input style="width: 50px;" type="text" value="0.016"/>								
Max. Allowable Spread for Minor & Major Storm	<table style="width: 100%; border: none;"> <tr> <td style="text-align: center; border: none;">$T_{MAX} =$</td> <td style="border: none; text-align: center;">Minor Storm</td> <td style="border: none; text-align: center;">Major Storm</td> <td style="border: none;"></td> </tr> <tr> <td style="border: none;"></td> <td style="border: 1px solid black; text-align: center; width: 50px;">17.0</td> <td style="border: 1px solid black; text-align: center; width: 50px;">17.0</td> <td style="border: none; text-align: right;">ft</td> </tr> </table>	$T_{MAX} = $	Minor Storm	Major Storm			17.0	17.0	ft
$T_{MAX} = $	Minor Storm	Major Storm							
	17.0	17.0	ft						
Max. Allowable Depth at Gutter Flowline for Minor & Major Storm	<table style="width: 100%; border: none;"> <tr> <td style="border: none;"></td> <td style="border: none; text-align: center;">Minor Storm</td> <td style="border: none; text-align: center;">Major Storm</td> <td style="border: none;"></td> </tr> <tr> <td style="border: none;"></td> <td style="border: 1px solid black; text-align: center; width: 50px;">4.0</td> <td style="border: 1px solid black; text-align: center; width: 50px;">12.0</td> <td style="border: none; text-align: right;">inches</td> </tr> </table>		Minor Storm	Major Storm			4.0	12.0	inches
	Minor Storm	Major Storm							
	4.0	12.0	inches						
Allow Flow Depth at Street Crown (leave blank for no)	<table style="width: 100%; border: none;"> <tr> <td style="border: none;"></td> <td style="border: none; text-align: center;"><input type="checkbox"/></td> <td style="border: none; text-align: center;"><input checked="" type="checkbox"/></td> <td style="border: none; text-align: right;">check = yes</td> </tr> </table>		<input type="checkbox"/>	<input checked="" type="checkbox"/>	check = yes				
	<input type="checkbox"/>	<input checked="" type="checkbox"/>	check = yes						
MINOR STORM Allowable Capacity is based on Depth Criterion									
MAJOR STORM Allowable Capacity is based on Depth Criterion	<table style="width: 100%; border: none;"> <tr> <td style="border: none;"></td> <td style="border: none; text-align: center;">Minor Storm</td> <td style="border: none; text-align: center;">Major Storm</td> <td style="border: none;"></td> </tr> <tr> <td style="border: none;"></td> <td style="border: 1px solid black; text-align: center; width: 50px;">3.4</td> <td style="border: 1px solid black; text-align: center; width: 50px;">91.2</td> <td style="border: none; text-align: right;">cfs</td> </tr> </table>		Minor Storm	Major Storm			3.4	91.2	cfs
	Minor Storm	Major Storm							
	3.4	91.2	cfs						
Minor storm max. allowable capacity GOOD - greater than flow given on sheet 'Q-Peak'									
Major storm max. allowable capacity GOOD - greater than flow given on sheet 'Q-Peak'									

INLET ON A CONTINUOUS GRADE

Project: COMPARK SOUTH
 Inlet ID: INLET 5-4A

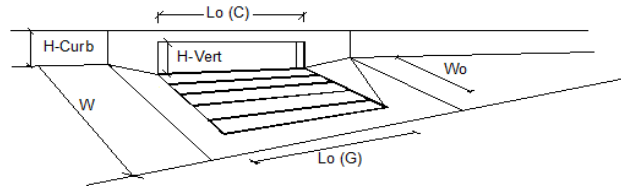

Design Information (Input)	MINOR		MAJOR		
	MINOR	MAJOR	MINOR	MAJOR	
Type of Inlet	CDOT Type R Curb Opening				
Local Depression (additional to continuous gutter depression 'a' from 'Q-Allow')	5.0	5.0			inches
Total Number of Units in the Inlet (Grate or Curb Opening)	1	1			
Length of a Single Unit Inlet (Grate or Curb Opening)	5.00	5.00			ft
Width of a Unit Grate (cannot be greater than W from Q-Allow)	N/A	N/A			ft
Clogging Factor for a Single Unit Grate (typical min. value = 0.5)	N/A	N/A			
Clogging Factor for a Single Unit Curb Opening (typical min. value = 0.1)	0.10	0.10			
Street Hydraulics: OK - Q < maximum allowable from sheet 'Q-Allow'					
Total Inlet Interception Capacity	1.00	2.22			cfs
Total Inlet Carry-Over Flow (flow bypassing inlet)	0.0	0.4			cfs
Capture Percentage = Q_a/Q_o =	100	85			%

**DESIGN PEAK FLOW FOR ONE-HALF OF STREET
OR GRASS-LINED CHANNEL BY THE RATIONAL METHOD**

Project: COMPARK SOUTH
 Inlet ID: INLET 5-5

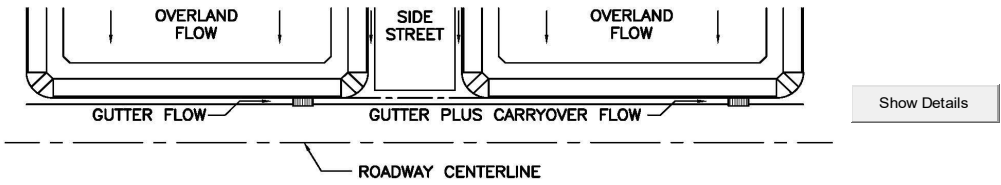

Design Flow: ONLY if already determined through other methods: (local peak flow for 1/2 of street OR grass-lined channel):		<table border="1" style="display: inline-table; border-collapse: collapse;"> <tr> <td style="padding: 2px;">Minor Storm</td> <td style="padding: 2px;">Major Storm</td> </tr> <tr> <td style="text-align: center; padding: 2px;">3.3</td> <td style="text-align: center; padding: 2px;">9.0</td> </tr> <tr> <td colspan="2" style="text-align: right; padding: 2px;">cfs</td> </tr> </table>	Minor Storm	Major Storm	3.3	9.0	cfs		<--- FILL IN THIS SECTION OR...																															
Minor Storm	Major Storm																																							
3.3	9.0																																							
cfs																																								
* If you enter values in Row 14, skip the rest of this sheet and proceed to sheet Q-Allow or Area Inlet.																																								
Geographic Information: (Enter data in the blue cells):																																								
Site Type: <input type="radio"/> Site is Urban <input type="radio"/> Site is Non-Urban	Flows Developed For: <input type="radio"/> Street Inlets <input type="radio"/> Area Inlets in a Median	Subcatchment Area = <input style="width: 50px;" type="text"/> Acres Percent Imperviousness = <input style="width: 50px;" type="text"/> % NRCS Soil Type = <input style="width: 50px;" type="text"/> A, B, C, or D	<--- FILL IN THE SECTIONS BELOW. <---																																					
		<table border="1" style="display: inline-table; border-collapse: collapse;"> <tr> <td style="padding: 2px;">Slope (ft/ft)</td> <td style="padding: 2px;">Length (ft)</td> </tr> <tr> <td style="padding: 2px;">Overland Flow = <input style="width: 50px;" type="text"/></td> <td style="padding: 2px;"><input style="width: 50px;" type="text"/></td> </tr> <tr> <td style="padding: 2px;">Channel Flow = <input style="width: 50px;" type="text"/></td> <td style="padding: 2px;"><input style="width: 50px;" type="text"/></td> </tr> </table>	Slope (ft/ft)	Length (ft)	Overland Flow = <input style="width: 50px;" type="text"/>	<input style="width: 50px;" type="text"/>	Channel Flow = <input style="width: 50px;" type="text"/>	<input style="width: 50px;" type="text"/>																																
Slope (ft/ft)	Length (ft)																																							
Overland Flow = <input style="width: 50px;" type="text"/>	<input style="width: 50px;" type="text"/>																																							
Channel Flow = <input style="width: 50px;" type="text"/>	<input style="width: 50px;" type="text"/>																																							
Rainfall Information: Intensity I (inch/hr) = $C_1 * P_1 / (C_2 + T_c)^{C_3}$		<table border="1" style="display: inline-table; border-collapse: collapse;"> <tr> <td style="padding: 2px;">Minor Storm</td> <td style="padding: 2px;">Major Storm</td> </tr> <tr> <td style="padding: 2px;">Design Storm Return Period, T_r = <input style="width: 50px;" type="text"/></td> <td style="padding: 2px;"><input style="width: 50px;" type="text"/></td> </tr> <tr> <td colspan="2" style="text-align: right; padding: 2px;">years</td> </tr> <tr> <td style="padding: 2px;">Return Period One-Hour Precipitation, P_1 = <input style="width: 50px;" type="text"/></td> <td style="padding: 2px;"><input style="width: 50px;" type="text"/></td> </tr> <tr> <td colspan="2" style="text-align: right; padding: 2px;">inches</td> </tr> <tr> <td style="padding: 2px;">C_1 = <input style="width: 50px;" type="text"/></td> <td style="padding: 2px;"><input style="width: 50px;" type="text"/></td> </tr> <tr> <td style="padding: 2px;">C_2 = <input style="width: 50px;" type="text"/></td> <td style="padding: 2px;"><input style="width: 50px;" type="text"/></td> </tr> <tr> <td style="padding: 2px;">C_3 = <input style="width: 50px;" type="text"/></td> <td style="padding: 2px;"><input style="width: 50px;" type="text"/></td> </tr> <tr> <td style="padding: 2px;">User-Defined Storm Runoff Coefficient (leave this blank to accept a calculated value), C = <input style="width: 50px;" type="text"/></td> <td style="padding: 2px;"><input style="width: 50px;" type="text"/></td> </tr> <tr> <td style="padding: 2px;">User-Defined 5-yr. Runoff Coefficient (leave this blank to accept a calculated value), C_5 = <input style="width: 50px;" type="text"/></td> <td style="padding: 2px;"><input style="width: 50px;" type="text"/></td> </tr> <tr> <td style="padding: 2px;">Bypass (Carry-Over) Flow from upstream Subcatchments, Q_b = <input style="width: 50px;" type="text"/></td> <td style="padding: 2px;"><input style="width: 50px;" type="text"/></td> </tr> <tr> <td colspan="2" style="text-align: right; padding: 2px;">cfs</td> </tr> <tr> <td colspan="2" style="padding: 2px;">Total Design Peak Flow, Q = <input style="width: 50px;" type="text"/></td> <td style="padding: 2px;"><input style="width: 50px;" type="text"/></td> <td style="padding: 2px;">cfs</td> </tr> <tr> <td colspan="2"></td> <td style="text-align: center;"> <table border="1" style="display: inline-table; border-collapse: collapse;"> <tr> <td style="padding: 2px;">Minor Storm</td> <td style="padding: 2px;">Major Storm</td> </tr> <tr> <td style="text-align: center; padding: 2px;">3.3</td> <td style="text-align: center; padding: 2px;">15.4</td> </tr> <tr> <td colspan="2" style="text-align: right; padding: 2px;">cfs</td> </tr> </table> </td> <td></td> </tr> </table>	Minor Storm	Major Storm	Design Storm Return Period, T_r = <input style="width: 50px;" type="text"/>	<input style="width: 50px;" type="text"/>	years		Return Period One-Hour Precipitation, P_1 = <input style="width: 50px;" type="text"/>	<input style="width: 50px;" type="text"/>	inches		C_1 = <input style="width: 50px;" type="text"/>	<input style="width: 50px;" type="text"/>	C_2 = <input style="width: 50px;" type="text"/>	<input style="width: 50px;" type="text"/>	C_3 = <input style="width: 50px;" type="text"/>	<input style="width: 50px;" type="text"/>	User-Defined Storm Runoff Coefficient (leave this blank to accept a calculated value), C = <input style="width: 50px;" type="text"/>	<input style="width: 50px;" type="text"/>	User-Defined 5-yr. Runoff Coefficient (leave this blank to accept a calculated value), C_5 = <input style="width: 50px;" type="text"/>	<input style="width: 50px;" type="text"/>	Bypass (Carry-Over) Flow from upstream Subcatchments, Q_b = <input style="width: 50px;" type="text"/>	<input style="width: 50px;" type="text"/>	cfs		Total Design Peak Flow, Q = <input style="width: 50px;" type="text"/>		<input style="width: 50px;" type="text"/>	cfs			<table border="1" style="display: inline-table; border-collapse: collapse;"> <tr> <td style="padding: 2px;">Minor Storm</td> <td style="padding: 2px;">Major Storm</td> </tr> <tr> <td style="text-align: center; padding: 2px;">3.3</td> <td style="text-align: center; padding: 2px;">15.4</td> </tr> <tr> <td colspan="2" style="text-align: right; padding: 2px;">cfs</td> </tr> </table>	Minor Storm	Major Storm	3.3	15.4	cfs		
Minor Storm	Major Storm																																							
Design Storm Return Period, T_r = <input style="width: 50px;" type="text"/>	<input style="width: 50px;" type="text"/>																																							
years																																								
Return Period One-Hour Precipitation, P_1 = <input style="width: 50px;" type="text"/>	<input style="width: 50px;" type="text"/>																																							
inches																																								
C_1 = <input style="width: 50px;" type="text"/>	<input style="width: 50px;" type="text"/>																																							
C_2 = <input style="width: 50px;" type="text"/>	<input style="width: 50px;" type="text"/>																																							
C_3 = <input style="width: 50px;" type="text"/>	<input style="width: 50px;" type="text"/>																																							
User-Defined Storm Runoff Coefficient (leave this blank to accept a calculated value), C = <input style="width: 50px;" type="text"/>	<input style="width: 50px;" type="text"/>																																							
User-Defined 5-yr. Runoff Coefficient (leave this blank to accept a calculated value), C_5 = <input style="width: 50px;" type="text"/>	<input style="width: 50px;" type="text"/>																																							
Bypass (Carry-Over) Flow from upstream Subcatchments, Q_b = <input style="width: 50px;" type="text"/>	<input style="width: 50px;" type="text"/>																																							
cfs																																								
Total Design Peak Flow, Q = <input style="width: 50px;" type="text"/>		<input style="width: 50px;" type="text"/>	cfs																																					
		<table border="1" style="display: inline-table; border-collapse: collapse;"> <tr> <td style="padding: 2px;">Minor Storm</td> <td style="padding: 2px;">Major Storm</td> </tr> <tr> <td style="text-align: center; padding: 2px;">3.3</td> <td style="text-align: center; padding: 2px;">15.4</td> </tr> <tr> <td colspan="2" style="text-align: right; padding: 2px;">cfs</td> </tr> </table>	Minor Storm	Major Storm	3.3	15.4	cfs																																	
Minor Storm	Major Storm																																							
3.3	15.4																																							
cfs																																								

ALLOWABLE CAPACITY FOR ONE-HALF OF STREET (Minor & Major Storm)

(Based on Regulated Criteria for Maximum Allowable Flow Depth and Spread)

Project: **COMPARK SOUTH**
 Inlet ID: **INLET 5-5**

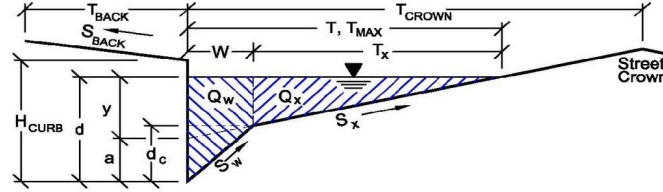

Gutter Geometry (Enter data in the blue cells)						
Maximum Allowable Width for Spread Behind Curb	$T_{BACK} =$	0.0 ft				
Side Slope Behind Curb (leave blank for no conveyance credit behind curb)	$S_{BACK} =$	0.020 ft/ft				
Manning's Roughness Behind Curb (typically between 0.012 and 0.020)	$n_{BACK} =$	0.020				
Height of Curb at Gutter Flow Line	$H_{CURB} =$	4.00 inches				
Distance from Curb Face to Street Crown	$T_{CROWN} =$	17.0 ft				
Gutter Width	$W =$	2.00 ft				
Street Transverse Slope	$S_x =$	0.020 ft/ft				
Gutter Cross Slope (typically 2 inches over 24 inches or 0.083 ft/ft)	$S_w =$	0.083 ft/ft				
Street Longitudinal Slope - Enter 0 for sump condition	$S_o =$	0.000 ft/ft				
Manning's Roughness for Street Section (typically between 0.012 and 0.020)	$n_{STREET} =$	0.016				
Max. Allowable Spread for Minor & Major Storm	$T_{MAX} =$	<table border="1"> <tr> <th>Minor Storm</th> <th>Major Storm</th> </tr> <tr> <td>17.0</td> <td>17.0</td> </tr> </table> ft	Minor Storm	Major Storm	17.0	17.0
Minor Storm	Major Storm					
17.0	17.0					
Max. Allowable Depth at Gutter Flowline for Minor & Major Storm	$d_{MAX} =$	<table border="1"> <tr> <th>Minor Storm</th> <th>Major Storm</th> </tr> <tr> <td>4.0</td> <td>12.0</td> </tr> </table> inches	Minor Storm	Major Storm	4.0	12.0
Minor Storm	Major Storm					
4.0	12.0					
Allow Flow Depth at Street Crown (leave blank for no)		<input type="checkbox"/> <input checked="" type="checkbox"/> check = yes				
MINOR STORM Allowable Capacity is based on Depth Criterion						
MAJOR STORM Allowable Capacity is based on Depth Criterion						
Minor storm max. allowable capacity GOOD - greater than flow given on sheet 'Q-Peak'						
Major storm max. allowable capacity GOOD - greater than flow given on sheet 'Q-Peak'						
$Q_{allow} =$	<table border="1"> <tr> <th>Minor Storm</th> <th>Major Storm</th> </tr> <tr> <td>SUMP</td> <td>SUMP</td> </tr> </table> cfs	Minor Storm	Major Storm	SUMP	SUMP	
Minor Storm	Major Storm					
SUMP	SUMP					

INLET IN A SUMP OR SAG LOCATION

Project = **COMPARK SOUTH**
 Inlet ID = **INLET 5-5**

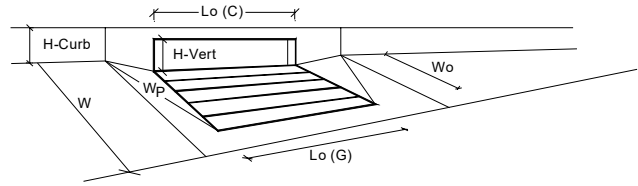

Design Information (Input)	MINOR		MAJOR		
	Type of Inlet	CDOT Type R Curb Opening			
Local Depression (additional to continuous gutter depression 'a' from 'Q-Allow')	a_{local} =	5.00	5.00	inches	
Number of Unit Inlets (Grate or Curb Opening)	N_o =	2	2		
Water Depth at Flowline (outside of local depression)	Ponding Depth =	4.1	12.0	inches	
Grate Information		MINOR		MAJOR	
Length of a Unit Grate	$L_o (G)$ =	N/A	N/A	feet	
Width of a Unit Grate	W_o =	N/A	N/A	feet	
Area Opening Ratio for a Grate (typical values 0.15-0.90)	A_{ratio} =	N/A	N/A		
Clogging Factor for a Single Grate (typical value 0.50 - 0.70)	$C_r (G)$ =	N/A	N/A		
Grate Weir Coefficient (typical value 2.15 - 3.60)	$C_w (G)$ =	N/A	N/A		
Grate Orifice Coefficient (typical value 0.60 - 0.80)	$C_o (G)$ =	N/A	N/A		
Curb Opening Information		MINOR		MAJOR	
Length of a Unit Curb Opening	$L_o (C)$ =	5.00	5.00	feet	
Height of Vertical Curb Opening in Inches	H_{vert} =	6.00	6.00	inches	
Height of Curb Orifice Throat in Inches	H_{throat} =	6.00	6.00	inches	
Angle of Throat (see USDCM Figure ST-5)	Theta =	63.40	63.40	degrees	
Side Width for Depression Pan (typically the gutter width of 2 feet)	W_p =	2.00	2.00	feet	
Clogging Factor for a Single Curb Opening (typical value 0.10)	$C_r (C)$ =	0.10	0.10		
Curb Opening Weir Coefficient (typical value 2.3-3.7)	$C_w (C)$ =	3.60	3.60		
Curb Opening Orifice Coefficient (typical value 0.60 - 0.70)	$C_o (C)$ =	0.67	0.67		
Total Inlet Interception Capacity (assumes clogged condition)		MINOR		MAJOR	
	Q_a =	3.4	27.5	cfs	
Inlet Capacity IS GOOD for Minor and Major Storms (>Q PEAK)	$Q_{PEAK REQUIRED}$ =	3.3	15.4	cfs	

**DESIGN PEAK FLOW FOR ONE-HALF OF STREET
OR GRASS-LINED CHANNEL BY THE RATIONAL METHOD**

Project: COMPARK SOUTH
Inlet ID: INLET 5-5A

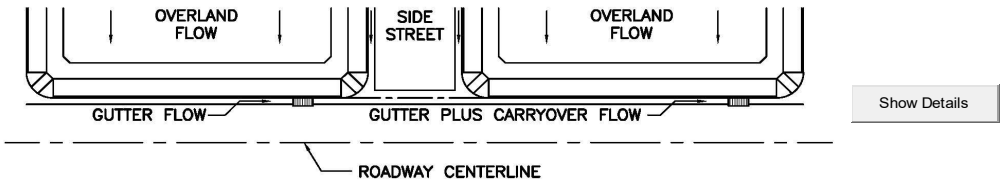

Design Flow: ONLY if already determined through other methods: (local peak flow for 1/2 of street OR grass-lined channel):		<table border="1" style="display: inline-table; border-collapse: collapse;"> <tr> <td style="padding: 2px;">Minor Storm</td> <td style="padding: 2px;">Major Storm</td> </tr> <tr> <td style="text-align: center; padding: 2px;">4.2</td> <td style="text-align: center; padding: 2px;">12.1</td> </tr> </table> cfs	Minor Storm	Major Storm	4.2	12.1	<--- FILL IN THIS SECTION OR... FILL IN THE SECTIONS BELOW. <---																							
Minor Storm	Major Storm																													
4.2	12.1																													
* If you enter values in Row 14, skip the rest of this sheet and proceed to sheet Q-Allow or Area Inlet.																														
Geographic Information: (Enter data in the blue cells):																														
Site Type: <input type="radio"/> Site is Urban <input type="radio"/> Site is Non-Urban	Flows Developed For: <input type="radio"/> Street Inlets <input type="radio"/> Area Inlets in a Median	Subcatchment Area = <input style="width: 50px;" type="text"/> Acres Percent Imperviousness = <input style="width: 50px;" type="text"/> % NRCS Soil Type = <input style="width: 50px;" type="text"/> A, B, C, or D																												
		<table border="1" style="display: inline-table; border-collapse: collapse;"> <tr> <td style="padding: 2px;">Slope (ft/ft)</td> <td style="padding: 2px;">Length (ft)</td> </tr> <tr> <td style="padding: 2px;">Overland Flow = <input style="width: 50px;" type="text"/></td> <td style="padding: 2px;">Channel Flow = <input style="width: 50px;" type="text"/></td> </tr> </table>	Slope (ft/ft)	Length (ft)	Overland Flow = <input style="width: 50px;" type="text"/>	Channel Flow = <input style="width: 50px;" type="text"/>																								
Slope (ft/ft)	Length (ft)																													
Overland Flow = <input style="width: 50px;" type="text"/>	Channel Flow = <input style="width: 50px;" type="text"/>																													
Rainfall Information: Intensity I (inch/hr) = $C_1 * P_1 / (C_2 + T_c)^{C_3}$																														
		<table border="1" style="display: inline-table; border-collapse: collapse;"> <tr> <td style="padding: 2px;">Design Storm Return Period, T_r =</td> <td style="padding: 2px;">Minor Storm</td> <td style="padding: 2px;">Major Storm</td> <td style="padding: 2px;">years</td> </tr> <tr> <td style="padding: 2px;">Return Period One-Hour Precipitation, P_1 =</td> <td style="padding: 2px;"></td> <td style="padding: 2px;"></td> <td style="padding: 2px;">inches</td> </tr> <tr> <td style="padding: 2px;">C_1 =</td> <td style="padding: 2px;"></td> <td style="padding: 2px;"></td> <td style="padding: 2px;"></td> </tr> <tr> <td style="padding: 2px;">C_2 =</td> <td style="padding: 2px;"></td> <td style="padding: 2px;"></td> <td style="padding: 2px;"></td> </tr> <tr> <td style="padding: 2px;">C_3 =</td> <td style="padding: 2px;"></td> <td style="padding: 2px;"></td> <td style="padding: 2px;"></td> </tr> <tr> <td style="padding: 2px;">User-Defined Storm Runoff Coefficient (leave this blank to accept a calculated value), C =</td> <td style="padding: 2px;"></td> <td style="padding: 2px;"></td> <td style="padding: 2px;"></td> </tr> <tr> <td style="padding: 2px;">User-Defined 5-yr. Runoff Coefficient (leave this blank to accept a calculated value), C_5 =</td> <td style="padding: 2px;"></td> <td style="padding: 2px;"></td> <td style="padding: 2px;"></td> </tr> </table>	Design Storm Return Period, T_r =	Minor Storm	Major Storm	years	Return Period One-Hour Precipitation, P_1 =			inches	C_1 =				C_2 =				C_3 =				User-Defined Storm Runoff Coefficient (leave this blank to accept a calculated value), C =				User-Defined 5-yr. Runoff Coefficient (leave this blank to accept a calculated value), C_5 =			
Design Storm Return Period, T_r =	Minor Storm	Major Storm	years																											
Return Period One-Hour Precipitation, P_1 =			inches																											
C_1 =																														
C_2 =																														
C_3 =																														
User-Defined Storm Runoff Coefficient (leave this blank to accept a calculated value), C =																														
User-Defined 5-yr. Runoff Coefficient (leave this blank to accept a calculated value), C_5 =																														
		Bypass (Carry-Over) Flow from upstream Subcatchments, Q_b = <table border="1" style="display: inline-table; border-collapse: collapse;"><tr><td style="padding: 2px;">0.0</td><td style="padding: 2px;">0.2</td></tr></table> cfs	0.0	0.2																										
0.0	0.2																													
		Total Design Peak Flow, Q = <table border="1" style="display: inline-table; border-collapse: collapse;"><tr><td style="padding: 2px;">4.2</td><td style="padding: 2px;">12.3</td></tr></table> cfs	4.2	12.3																										
4.2	12.3																													

ALLOWABLE CAPACITY FOR ONE-HALF OF STREET (Minor & Major Storm)

(Based on Regulated Criteria for Maximum Allowable Flow Depth and Spread)

Project: **COMPARK SOUTH**
 Inlet ID: **INLET 5-5A**

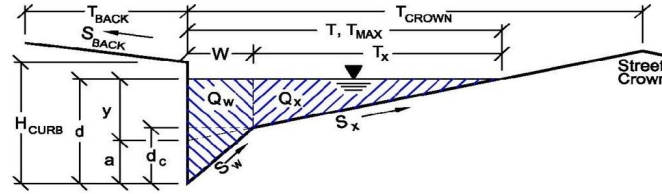

Gutter Geometry (Enter data in the blue cells)					
Maximum Allowable Width for Spread Behind Curb	$T_{BACK} = 0.0$ ft				
Side Slope Behind Curb (leave blank for no conveyance credit behind curb)	$S_{BACK} = 0.020$ ft/ft				
Manning's Roughness Behind Curb (typically between 0.012 and 0.020)	$n_{BACK} = 0.020$				
Height of Curb at Gutter Flow Line	$H_{CURB} = 4.00$ inches				
Distance from Curb Face to Street Crown	$T_{CROWN} = 17.0$ ft				
Gutter Width	$W = 2.00$ ft				
Street Transverse Slope	$S_x = 0.020$ ft/ft				
Gutter Cross Slope (typically 2 inches over 24 inches or 0.083 ft/ft)	$S_w = 0.083$ ft/ft				
Street Longitudinal Slope - Enter 0 for sump condition	$S_o = 0.010$ ft/ft				
Manning's Roughness for Street Section (typically between 0.012 and 0.020)	$n_{STREET} = 0.016$				
Max. Allowable Spread for Minor & Major Storm	<table style="width: 100%; border: none;"> <tr> <td style="text-align: center; border: none;">$T_{MAX} =$</td> <td style="border: 1px solid black; width: 50px; text-align: center;">17.0</td> <td style="border: 1px solid black; width: 50px; text-align: center;">17.0</td> <td style="border: none;">ft</td> </tr> </table>	$T_{MAX} =$	17.0	17.0	ft
$T_{MAX} =$	17.0	17.0	ft		
Max. Allowable Depth at Gutter Flowline for Minor & Major Storm	<table style="width: 100%; border: none;"> <tr> <td style="text-align: center; border: none;">$d_{MAX} =$</td> <td style="border: 1px solid black; width: 50px; text-align: center;">4.3</td> <td style="border: 1px solid black; width: 50px; text-align: center;">12.0</td> <td style="border: none;">inches</td> </tr> </table>	$d_{MAX} =$	4.3	12.0	inches
$d_{MAX} =$	4.3	12.0	inches		
Allow Flow Depth at Street Crown (leave blank for no)	<table style="width: 100%; border: none;"> <tr> <td style="text-align: center; border: none;"><input type="checkbox"/></td> <td style="text-align: center; border: none;"><input checked="" type="checkbox"/></td> <td style="border: none;">check = yes</td> </tr> </table>	<input type="checkbox"/>	<input checked="" type="checkbox"/>	check = yes	
<input type="checkbox"/>	<input checked="" type="checkbox"/>	check = yes			
MINOR STORM Allowable Capacity is based on Depth Criterion					
MAJOR STORM Allowable Capacity is based on Depth Criterion					
Minor storm max. allowable capacity GOOD - greater than flow given on sheet 'Q-Peak'					
Major storm max. allowable capacity GOOD - greater than flow given on sheet 'Q-Peak'					
$Q_{allow} =$	<table style="width: 100%; border: none;"> <tr> <td style="text-align: center; border: none;">$Q_{allow} =$</td> <td style="border: 1px solid black; width: 50px; text-align: center;">4.4</td> <td style="border: 1px solid black; width: 50px; text-align: center;">91.2</td> <td style="border: none;">cfs</td> </tr> </table>	$Q_{allow} =$	4.4	91.2	cfs
$Q_{allow} =$	4.4	91.2	cfs		

INLET ON A CONTINUOUS GRADE

Project: COMPARK SOUTH
 Inlet ID: INLET 5-5A

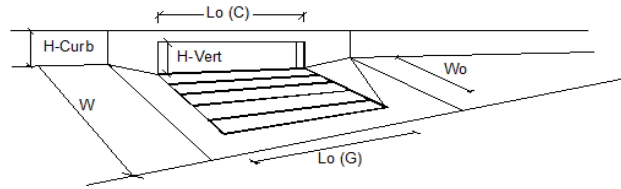

Design Information (Input)	MINOR		MAJOR	
	Type of Inlet	Type = CDOT Type R Curb Opening		
Local Depression (additional to continuous gutter depression 'a' from 'Q-Allow')	$a_{LOCAL} = 3.0$	3.0	inches	
Total Number of Units in the Inlet (Grate or Curb Opening)	$N_o = 3$	3		
Length of a Single Unit Inlet (Grate or Curb Opening)	$L_o = 5.00$	5.00	ft	
Width of a Unit Grate (cannot be greater than W from Q-Allow)	$W_o = N/A$	N/A	ft	
Clogging Factor for a Single Unit Grate (typical min. value = 0.5)	$C_r-G = N/A$	N/A		
Clogging Factor for a Single Unit Curb Opening (typical min. value = 0.1)	$C_r-C = 0.10$	0.10		
Street Hydraulics: OK - Q < maximum allowable from sheet 'Q-Allow'				
Total Inlet Interception Capacity	$Q = 4.20$	10.62	cfs	
Total Inlet Carry-Over Flow (flow bypassing inlet)	$Q_b = 0.0$	1.7	cfs	
Capture Percentage = $Q_a/Q_o =$	$C\% = 100$	86	%	

**DESIGN PEAK FLOW FOR ONE-HALF OF STREET
OR GRASS-LINED CHANNEL BY THE RATIONAL METHOD**

Project: COMPARK SOUTH
 Inlet ID: INLET 5-5B

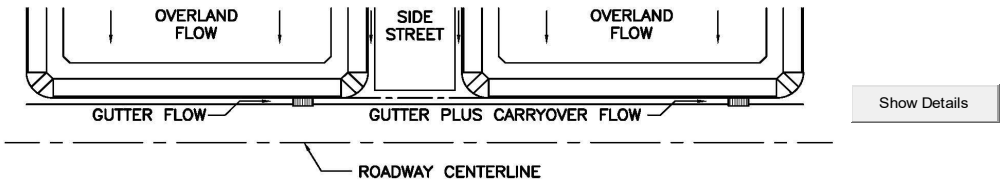

Design Flow: ONLY if already determined through other methods: (local peak flow for 1/2 of street OR grass-lined channel):		Minor Storm Major Storm *Q _{known} = <input type="text" value="3.4"/> <input type="text" value="9.3"/> cfs	<--- FILL IN THIS SECTION OR... FILL IN THE SECTIONS BELOW. <---
Geographic Information: (Enter data in the blue cells):		Subcatchment Area = <input type="text"/> Acres Percent Imperviousness = <input type="text"/> % NRCS Soil Type = <input type="text"/> A, B, C, or D	
Site Type: <input type="radio"/> Site is Urban <input type="radio"/> Site is Non-Urban	Flows Developed For: <input type="radio"/> Street Inlets <input type="radio"/> Area Inlets in a Median	Slope (ft/ft) Length (ft) Overland Flow = <input type="text"/> <input type="text"/> Channel Flow = <input type="text"/> <input type="text"/>	
Rainfall Information: Intensity I (inch/hr) = $C_1 * P_1 / (C_2 + T_c)^{C_3}$		Minor Storm Major Storm	
		Design Storm Return Period, T _r = <input type="text"/> years	
		Return Period One-Hour Precipitation, P ₁ = <input type="text"/> inches	
		C ₁ = <input type="text"/>	
		C ₂ = <input type="text"/>	
		C ₃ = <input type="text"/>	
User-Defined Storm Runoff Coefficient (leave this blank to accept a calculated value), C = <input type="text"/>		User-Defined 5-yr. Runoff Coefficient (leave this blank to accept a calculated value), C ₅ = <input type="text"/>	
		Bypass (Carry-Over) Flow from upstream Subcatchments, Q _b = <input type="text" value="0.0"/> <input type="text" value="0.0"/> cfs	
		Total Design Peak Flow, Q = <input type="text" value="3.4"/> <input type="text" value="9.3"/> cfs	

ALLOWABLE CAPACITY FOR ONE-HALF OF STREET (Minor & Major Storm)

(Based on Regulated Criteria for Maximum Allowable Flow Depth and Spread)

Project: **COMPARK SOUTH**
 Inlet ID: **INLET 5-5B**

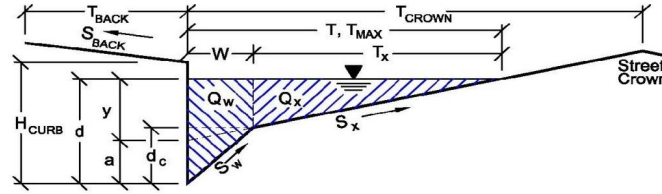

Gutter Geometry (Enter data in the blue cells)					
Maximum Allowable Width for Spread Behind Curb	$T_{BACK} = 0.0$ ft				
Side Slope Behind Curb (leave blank for no conveyance credit behind curb)	$S_{BACK} = 0.020$ ft/ft				
Manning's Roughness Behind Curb (typically between 0.012 and 0.020)	$n_{BACK} = 0.020$				
Height of Curb at Gutter Flow Line	$H_{CURB} = 4.01$ inches				
Distance from Curb Face to Street Crown	$T_{CROWN} = 17.0$ ft				
Gutter Width	$W = 2.00$ ft				
Street Transverse Slope	$S_x = 0.020$ ft/ft				
Gutter Cross Slope (typically 2 inches over 24 inches or 0.083 ft/ft)	$S_w = 0.083$ ft/ft				
Street Longitudinal Slope - Enter 0 for sump condition	$S_o = 0.010$ ft/ft				
Manning's Roughness for Street Section (typically between 0.012 and 0.020)	$n_{STREET} = 0.016$				
Max. Allowable Spread for Minor & Major Storm	<table border="1" style="display: inline-table; border-collapse: collapse;"> <thead> <tr> <th style="width: 50%;">Minor Storm</th> <th style="width: 50%;">Major Storm</th> </tr> </thead> <tbody> <tr> <td style="text-align: center;">$T_{MAX} = 17.0$</td> <td style="text-align: center;">$T_{MAX} = 17.0$</td> </tr> </tbody> </table> ft	Minor Storm	Major Storm	$T_{MAX} = 17.0$	$T_{MAX} = 17.0$
Minor Storm	Major Storm				
$T_{MAX} = 17.0$	$T_{MAX} = 17.0$				
Max. Allowable Depth at Gutter Flowline for Minor & Major Storm	<table border="1" style="display: inline-table; border-collapse: collapse;"> <thead> <tr> <th style="width: 50%;">Minor Storm</th> <th style="width: 50%;">Major Storm</th> </tr> </thead> <tbody> <tr> <td style="text-align: center;">$d_{MAX} = 4.0$</td> <td style="text-align: center;">$d_{MAX} = 12.0$</td> </tr> </tbody> </table> inches	Minor Storm	Major Storm	$d_{MAX} = 4.0$	$d_{MAX} = 12.0$
Minor Storm	Major Storm				
$d_{MAX} = 4.0$	$d_{MAX} = 12.0$				
Allow Flow Depth at Street Crown (leave blank for no)	<input type="checkbox"/> <input checked="" type="checkbox"/> check = yes				
MINOR STORM Allowable Capacity is based on Depth Criterion					
MAJOR STORM Allowable Capacity is based on Depth Criterion					
Minor storm max. allowable capacity GOOD - greater than flow given on sheet 'Q-Peak'	<table border="1" style="display: inline-table; border-collapse: collapse;"> <thead> <tr> <th style="width: 50%;">Minor Storm</th> <th style="width: 50%;">Major Storm</th> </tr> </thead> <tbody> <tr> <td style="text-align: center;">$Q_{allow} = 3.4$</td> <td style="text-align: center;">$Q_{allow} = 91.2$</td> </tr> </tbody> </table> cfs	Minor Storm	Major Storm	$Q_{allow} = 3.4$	$Q_{allow} = 91.2$
Minor Storm	Major Storm				
$Q_{allow} = 3.4$	$Q_{allow} = 91.2$				
Major storm max. allowable capacity GOOD - greater than flow given on sheet 'Q-Peak'					

INLET ON A CONTINUOUS GRADE

Project: COMPARK SOUTH
 Inlet ID: INLET 5-5B

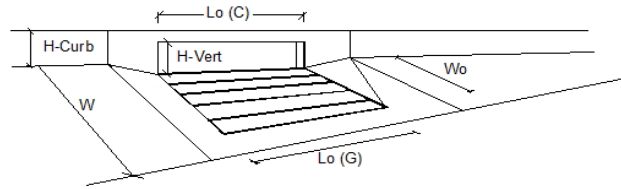

Design Information (Input)	MINOR		MAJOR	
	Type of Inlet	Type = CDOT Type R Curb Opening		
Local Depression (additional to continuous gutter depression 'a' from 'Q-Allow')	a _{LOCAL} = 5.0	5.0	inches	
Total Number of Units in the Inlet (Grate or Curb Opening)	No = 2	2		
Length of a Single Unit Inlet (Grate or Curb Opening)	L _o = 5.00	5.00	ft	
Width of a Unit Grate (cannot be greater than W from Q-Allow)	W _o = N/A	N/A	ft	
Clogging Factor for a Single Unit Grate (typical min. value = 0.5)	C _{r-G} = N/A	N/A		
Clogging Factor for a Single Unit Curb Opening (typical min. value = 0.1)	C _{r-C} = 0.10	0.10		
Street Hydraulics: OK - Q < maximum allowable from sheet 'Q-Allow'				
Total Inlet Interception Capacity	Q = 3.40	7.54	cfs	
Total Inlet Carry-Over Flow (flow bypassing inlet)	Q _b = 0.0	1.8	cfs	
Capture Percentage = Q _a /Q _o =	C% = 100	81	%	

**DESIGN PEAK FLOW FOR ONE-HALF OF STREET
OR GRASS-LINED CHANNEL BY THE RATIONAL METHOD**

Project: COMPARK SOUTH
 Inlet ID: INLET 6-4

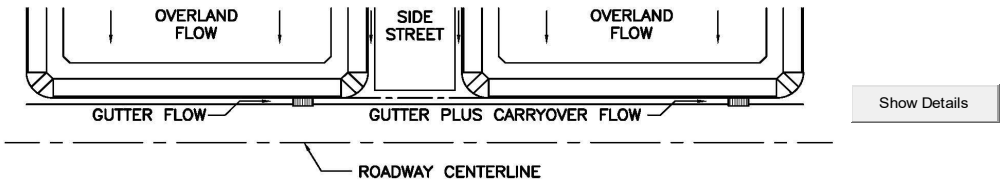

Design Flow: ONLY if already determined through other methods: (local peak flow for 1/2 of street OR grass-lined channel):		<table border="1" style="display: inline-table; border-collapse: collapse;"> <tr> <td style="padding: 2px;">Minor Storm</td> <td style="padding: 2px;">Major Storm</td> </tr> <tr> <td style="text-align: center; padding: 2px;">1.1</td> <td style="text-align: center; padding: 2px;">3.5</td> </tr> </table> cfs	Minor Storm	Major Storm	1.1	3.5	<--- FILL IN THIS SECTION OR... FILL IN THE SECTIONS BELOW. <---																								
Minor Storm	Major Storm																														
1.1	3.5																														
* If you enter values in Row 14, skip the rest of this sheet and proceed to sheet Q-Allow or Area Inlet.																															
Geographic Information: (Enter data in the blue cells):																															
Site Type: <input type="radio"/> Site is Urban <input type="radio"/> Site is Non-Urban	Flows Developed For: <input type="radio"/> Street Inlets <input type="radio"/> Area Inlets in a Median	Subcatchment Area = <input type="text"/> Acres Percent Imperviousness = <input type="text"/> % NRCS Soil Type = <input type="text"/> A, B, C, or D																													
		<table border="1" style="display: inline-table; border-collapse: collapse;"> <tr> <td style="padding: 2px;">Slope (ft/ft)</td> <td style="padding: 2px;">Length (ft)</td> </tr> <tr> <td style="padding: 2px;">Overland Flow = <input type="text"/></td> <td style="padding: 2px;">Channel Flow = <input type="text"/></td> </tr> </table>	Slope (ft/ft)	Length (ft)	Overland Flow = <input type="text"/>	Channel Flow = <input type="text"/>																									
Slope (ft/ft)	Length (ft)																														
Overland Flow = <input type="text"/>	Channel Flow = <input type="text"/>																														
Rainfall Information: Intensity I (inch/hr) = $C_1 * P_1 / (C_2 + T_c)^{C_3}$																															
		<table border="1" style="display: inline-table; border-collapse: collapse;"> <tr> <td style="padding: 2px;">Design Storm Return Period, T_r =</td> <td style="padding: 2px;">Minor Storm</td> <td style="padding: 2px;">Major Storm</td> <td style="padding: 2px;">years</td> </tr> <tr> <td style="padding: 2px;">Return Period One-Hour Precipitation, P_1 =</td> <td style="padding: 2px;"></td> <td style="padding: 2px;"></td> <td style="padding: 2px;">inches</td> </tr> <tr> <td style="padding: 2px;">C_1 =</td> <td style="padding: 2px;"></td> <td style="padding: 2px;"></td> <td style="padding: 2px;"></td> </tr> <tr> <td style="padding: 2px;">C_2 =</td> <td style="padding: 2px;"></td> <td style="padding: 2px;"></td> <td style="padding: 2px;"></td> </tr> <tr> <td style="padding: 2px;">C_3 =</td> <td style="padding: 2px;"></td> <td style="padding: 2px;"></td> <td style="padding: 2px;"></td> </tr> <tr> <td style="padding: 2px;">User-Defined Storm Runoff Coefficient (leave this blank to accept a calculated value), C =</td> <td style="padding: 2px;"></td> <td style="padding: 2px;"></td> <td style="padding: 2px;"></td> </tr> <tr> <td style="padding: 2px;">User-Defined 5-yr. Runoff Coefficient (leave this blank to accept a calculated value), C_5 =</td> <td style="padding: 2px;"></td> <td style="padding: 2px;"></td> <td style="padding: 2px;"></td> </tr> </table>	Design Storm Return Period, T_r =	Minor Storm	Major Storm	years	Return Period One-Hour Precipitation, P_1 =			inches	C_1 =				C_2 =				C_3 =				User-Defined Storm Runoff Coefficient (leave this blank to accept a calculated value), C =				User-Defined 5-yr. Runoff Coefficient (leave this blank to accept a calculated value), C_5 =				
Design Storm Return Period, T_r =	Minor Storm	Major Storm	years																												
Return Period One-Hour Precipitation, P_1 =			inches																												
C_1 =																															
C_2 =																															
C_3 =																															
User-Defined Storm Runoff Coefficient (leave this blank to accept a calculated value), C =																															
User-Defined 5-yr. Runoff Coefficient (leave this blank to accept a calculated value), C_5 =																															
		Bypass (Carry-Over) Flow from upstream Subcatchments, Q_b = <table border="1" style="display: inline-table; border-collapse: collapse;"><tr><td style="padding: 2px;">0.0</td><td style="padding: 2px;">0.0</td></tr></table> cfs	0.0	0.0																											
0.0	0.0																														
		Total Design Peak Flow, Q = <table border="1" style="display: inline-table; border-collapse: collapse;"><tr><td style="padding: 2px;">1.1</td><td style="padding: 2px;">3.5</td></tr></table> cfs	1.1	3.5																											
1.1	3.5																														

ALLOWABLE CAPACITY FOR ONE-HALF OF STREET (Minor & Major Storm)

(Based on Regulated Criteria for Maximum Allowable Flow Depth and Spread)

Project: **COMPARK SOUTH**
 Inlet ID: **INLET 6-4**

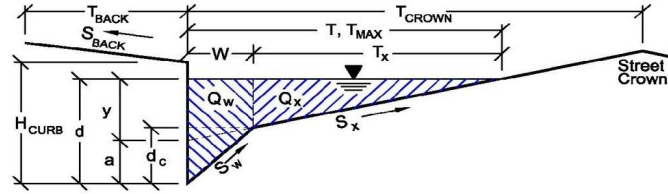

Gutter Geometry (Enter data in the blue cells)					
Maximum Allowable Width for Spread Behind Curb	$T_{BACK} = 0.0$ ft				
Side Slope Behind Curb (leave blank for no conveyance credit behind curb)	$S_{BACK} = 0.020$ ft/ft				
Manning's Roughness Behind Curb (typically between 0.012 and 0.020)	$n_{BACK} = 0.020$				
Height of Curb at Gutter Flow Line	$H_{CURB} = 4.00$ inches				
Distance from Curb Face to Street Crown	$T_{CROWN} = 17.0$ ft				
Gutter Width	$W = 2.00$ ft				
Street Transverse Slope	$S_x = 0.020$ ft/ft				
Gutter Cross Slope (typically 2 inches over 24 inches or 0.083 ft/ft)	$S_w = 0.083$ ft/ft				
Street Longitudinal Slope - Enter 0 for sump condition	$S_o = 0.006$ ft/ft				
Manning's Roughness for Street Section (typically between 0.012 and 0.020)	$n_{STREET} = 0.016$				
Max. Allowable Spread for Minor & Major Storm	<table border="1" style="display: inline-table; border-collapse: collapse;"> <thead> <tr> <th style="width: 50%;">Minor Storm</th> <th style="width: 50%;">Major Storm</th> </tr> </thead> <tbody> <tr> <td>$T_{MAX} = 17.0$</td> <td>$T_{MAX} = 17.0$</td> </tr> </tbody> </table> ft	Minor Storm	Major Storm	$T_{MAX} = 17.0$	$T_{MAX} = 17.0$
Minor Storm	Major Storm				
$T_{MAX} = 17.0$	$T_{MAX} = 17.0$				
Max. Allowable Depth at Gutter Flowline for Minor & Major Storm	<table border="1" style="display: inline-table; border-collapse: collapse;"> <thead> <tr> <th style="width: 50%;">Minor Storm</th> <th style="width: 50%;">Major Storm</th> </tr> </thead> <tbody> <tr> <td>$d_{MAX} = 4.0$</td> <td>$d_{MAX} = 12.0$</td> </tr> </tbody> </table> inches	Minor Storm	Major Storm	$d_{MAX} = 4.0$	$d_{MAX} = 12.0$
Minor Storm	Major Storm				
$d_{MAX} = 4.0$	$d_{MAX} = 12.0$				
Allow Flow Depth at Street Crown (leave blank for no)	<input type="checkbox"/> <input checked="" type="checkbox"/> check = yes				
MINOR STORM Allowable Capacity is based on Depth Criterion					
MAJOR STORM Allowable Capacity is based on Depth Criterion					
Minor storm max. allowable capacity GOOD - greater than flow given on sheet 'Q-Peak'					
Major storm max. allowable capacity GOOD - greater than flow given on sheet 'Q-Peak'					
Q_{allow}	<table border="1" style="display: inline-table; border-collapse: collapse;"> <thead> <tr> <th style="width: 50%;">Minor Storm</th> <th style="width: 50%;">Major Storm</th> </tr> </thead> <tbody> <tr> <td>2.6</td> <td>70.6</td> </tr> </tbody> </table> cfs	Minor Storm	Major Storm	2.6	70.6
Minor Storm	Major Storm				
2.6	70.6				

INLET ON A CONTINUOUS GRADE

Project: COMPARK SOUTH
 Inlet ID: INLET 6-4

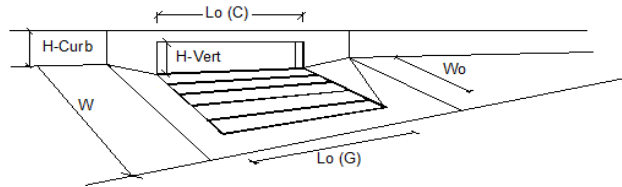

Design Information (Input)	MINOR		MAJOR	
	Type of Inlet	Type = CDOT Type R Curb Opening		
Local Depression (additional to continuous gutter depression 'a' from 'Q-Allow')	$a_{LOCAL} = 3.0$	3.0	inches	
Total Number of Units in the Inlet (Grate or Curb Opening)	$N_o = 2$	2		
Length of a Single Unit Inlet (Grate or Curb Opening)	$L_o = 5.00$	5.00	ft	
Width of a Unit Grate (cannot be greater than W from Q-Allow)	$W_o = N/A$	N/A	ft	
Clogging Factor for a Single Unit Grate (typical min. value = 0.5)	$C_r-G = N/A$	N/A		
Clogging Factor for a Single Unit Curb Opening (typical min. value = 0.1)	$C_r-C = 0.10$	0.10		
Street Hydraulics: OK - Q < maximum allowable from sheet 'Q-Allow'				
Total Inlet Interception Capacity	$Q = 1.10$	3.50	cfs	
Total Inlet Carry-Over Flow (flow bypassing inlet)	$Q_b = 0.0$	0.0	cfs	
Capture Percentage = $Q_a/Q_o =$	$C\% = 100$	100	%	

**DESIGN PEAK FLOW FOR ONE-HALF OF STREET
OR GRASS-LINED CHANNEL BY THE RATIONAL METHOD**

Project: COMPARK SOUTH
 Inlet ID: INLET 6-5

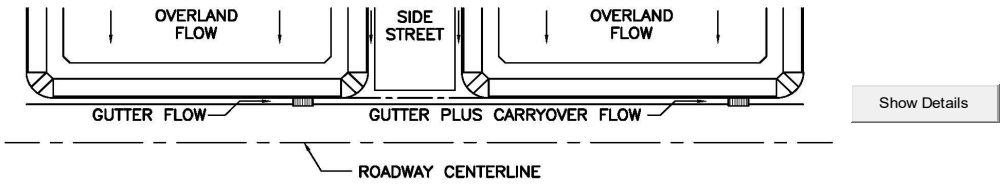

Design Flow: ONLY if already determined through other methods: (local peak flow for 1/2 of street OR grass-lined channel):		Minor Storm Major Storm * Q_{known} = <input type="text" value="3.9"/> <input type="text" value="17.6"/> cfs	<--- FILL IN THIS SECTION OR... FILL IN THE SECTIONS BELOW. <---
Geographic Information: (Enter data in the blue cells):		Subcatchment Area = <input type="text"/> Acres Percent Imperviousness = <input type="text"/> % NRCS Soil Type = <input type="text"/> A, B, C, or D	
Site Type: <input type="radio"/> Site is Urban <input type="radio"/> Site is Non-Urban	Flows Developed For: <input type="radio"/> Street Inlets <input type="radio"/> Area Inlets in a Median	Slope (ft/ft) Length (ft) Overland Flow = <input type="text"/> <input type="text"/> Channel Flow = <input type="text"/> <input type="text"/>	
Rainfall Information: Intensity I (inch/hr) = $C_1 * P_1 / (C_2 + T_c)^{C_3}$		Minor Storm Major Storm	
		Design Storm Return Period, T_r = <input type="text"/> years	
		Return Period One-Hour Precipitation, P_1 = <input type="text"/> inches	
		C_1 = <input type="text"/>	
		C_2 = <input type="text"/>	
		C_3 = <input type="text"/>	
User-Defined Storm Runoff Coefficient (leave this blank to accept a calculated value), C = <input type="text"/>		C = <input type="text"/>	
User-Defined 5-yr. Runoff Coefficient (leave this blank to accept a calculated value), C_5 = <input type="text"/>		C_5 = <input type="text"/>	
		Bypass (Carry-Over) Flow from upstream Subcatchments, Q_b = <input type="text" value="0.0"/> <input type="text" value="0.9"/> cfs	
		Total Design Peak Flow, Q = <input type="text" value="3.9"/> <input type="text" value="18.5"/> cfs	

ALLOWABLE CAPACITY FOR ONE-HALF OF STREET (Minor & Major Storm)

(Based on Regulated Criteria for Maximum Allowable Flow Depth and Spread)

Project:

COMPARK SOUTH

Inlet ID:

INLET 6-5

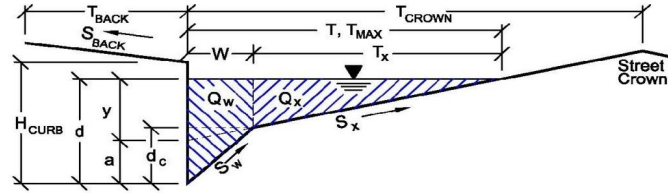

Gutter Geometry (Enter data in the blue cells)						
Maximum Allowable Width for Spread Behind Curb	$T_{BACK} =$	0.0 ft				
Side Slope Behind Curb (leave blank for no conveyance credit behind curb)	$S_{BACK} =$	0.020 ft/ft				
Manning's Roughness Behind Curb (typically between 0.012 and 0.020)	$n_{BACK} =$	0.020				
Height of Curb at Gutter Flow Line	$H_{CURB} =$	4.00 inches				
Distance from Curb Face to Street Crown	$T_{CROWN} =$	17.0 ft				
Gutter Width	$W =$	2.00 ft				
Street Transverse Slope	$S_x =$	0.020 ft/ft				
Gutter Cross Slope (typically 2 inches over 24 inches or 0.083 ft/ft)	$S_w =$	0.083 ft/ft				
Street Longitudinal Slope - Enter 0 for sump condition	$S_o =$	0.000 ft/ft				
Manning's Roughness for Street Section (typically between 0.012 and 0.020)	$n_{STREET} =$	0.013				
Max. Allowable Spread for Minor & Major Storm	$T_{MAX} =$	<table border="1" style="display: inline-table; border-collapse: collapse;"> <thead> <tr> <th style="padding: 2px;">Minor Storm</th> <th style="padding: 2px;">Major Storm</th> </tr> </thead> <tbody> <tr> <td style="text-align: center; padding: 2px;">17.0</td> <td style="text-align: center; padding: 2px;">17.0</td> </tr> </tbody> </table> ft	Minor Storm	Major Storm	17.0	17.0
Minor Storm	Major Storm					
17.0	17.0					
Max. Allowable Depth at Gutter Flowline for Minor & Major Storm	$d_{MAX} =$	<table border="1" style="display: inline-table; border-collapse: collapse;"> <thead> <tr> <th style="padding: 2px;">Minor Storm</th> <th style="padding: 2px;">Major Storm</th> </tr> </thead> <tbody> <tr> <td style="text-align: center; padding: 2px;">4.0</td> <td style="text-align: center; padding: 2px;">12.0</td> </tr> </tbody> </table> inches	Minor Storm	Major Storm	4.0	12.0
Minor Storm	Major Storm					
4.0	12.0					
Allow Flow Depth at Street Crown (leave blank for no)		<input type="checkbox"/> <input checked="" type="checkbox"/> check = yes				
MINOR STORM Allowable Capacity is based on Depth Criterion	$Q_{allow} =$	<table border="1" style="display: inline-table; border-collapse: collapse;"> <thead> <tr> <th style="padding: 2px;">Minor Storm</th> <th style="padding: 2px;">Major Storm</th> </tr> </thead> <tbody> <tr> <td style="text-align: center; padding: 2px;">SUMP</td> <td style="text-align: center; padding: 2px;">SUMP</td> </tr> </tbody> </table> cfs	Minor Storm	Major Storm	SUMP	SUMP
Minor Storm	Major Storm					
SUMP	SUMP					
MAJOR STORM Allowable Capacity is based on Depth Criterion						
Minor storm max. allowable capacity GOOD - greater than flow given on sheet 'Q-Peak' Major storm max. allowable capacity GOOD - greater than flow given on sheet 'Q-Peak'						

INLET IN A SUMP OR SAG LOCATION

Project = **COMPARK SOUTH**
 Inlet ID = **INLET 6-5**

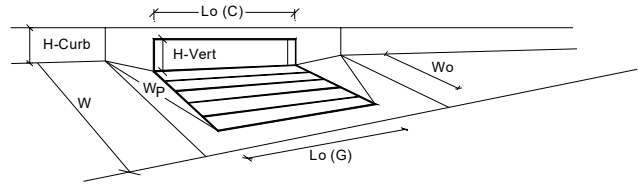

Design Information (Input)	MINOR		MAJOR	
	Type of Inlet	CDOT Type R Curb Opening		
Local Depression (additional to continuous gutter depression 'a' from 'Q-Allow')	a_{local} = 5.00	5.00	inches	
Number of Unit Inlets (Grate or Curb Opening)	N_o = 3	3		
Water Depth at Flowline (outside of local depression)	Ponding Depth = 4.0	12.0	inches	
Grate Information	<input checked="" type="checkbox"/> Override Depths			
Length of a Unit Grate	$L_o (G)$ = N/A	N/A	feet	
Width of a Unit Grate	W_o = N/A	N/A	feet	
Area Opening Ratio for a Grate (typical values 0.15-0.90)	A_{ratio} = N/A	N/A		
Clogging Factor for a Single Grate (typical value 0.50 - 0.70)	$C_r (G)$ = N/A	N/A		
Grate Weir Coefficient (typical value 2.15 - 3.60)	$C_w (G)$ = N/A	N/A		
Grate Orifice Coefficient (typical value 0.60 - 0.80)	$C_o (G)$ = N/A	N/A		
Curb Opening Information	MINOR		MAJOR	
Length of a Unit Curb Opening	$L_o (C)$ = 5.00	5.00	feet	
Height of Vertical Curb Opening in Inches	H_{vert} = 6.00	6.00	inches	
Height of Curb Orifice Throat in Inches	H_{throat} = 6.00	6.00	inches	
Angle of Throat (see USDCM Figure ST-5)	Theta = 63.40	63.40	degrees	
Side Width for Depression Pan (typically the gutter width of 2 feet)	W_p = 2.00	2.00	feet	
Clogging Factor for a Single Curb Opening (typical value 0.10)	$C_r (C)$ = 0.10	0.10		
Curb Opening Weir Coefficient (typical value 2.3-3.7)	$C_w (C)$ = 3.60	3.60		
Curb Opening Orifice Coefficient (typical value 0.60 - 0.70)	$C_o (C)$ = 0.67	0.67		
Total Inlet Interception Capacity (assumes clogged condition)	MINOR		MAJOR	
	Q_a = 3.9	42.1	cfs	
Inlet Capacity IS GOOD for Minor and Major Storms (>Q PEAK)	$Q_{PEAK REQUIRED}$ = 3.9	18.5	cfs	

**DESIGN PEAK FLOW FOR ONE-HALF OF STREET
OR GRASS-LINED CHANNEL BY THE RATIONAL METHOD**

Project: COMPARK SOUTH
 Inlet ID: INLET 6-5A

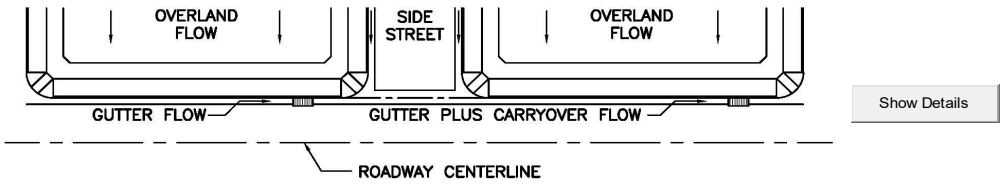

Design Flow: ONLY if already determined through other methods: (local peak flow for 1/2 of street OR grass-lined channel):		<table border="1" style="display: inline-table; border-collapse: collapse;"> <tr> <td style="padding: 2px;">Minor Storm</td> <td style="padding: 2px;">Major Storm</td> </tr> <tr> <td style="text-align: center;">2.6</td> <td style="text-align: center;">6.7</td> </tr> </table> cfs	Minor Storm	Major Storm	2.6	6.7	<--- FILL IN THIS SECTION OR... FILL IN THE SECTIONS BELOW. <---																																
Minor Storm	Major Storm																																						
2.6	6.7																																						
* If you enter values in Row 14, skip the rest of this sheet and proceed to sheet Q-Allow or Area Inlet.																																							
Geographic Information: (Enter data in the blue cells):		Subcatchment Area = <input style="width: 50px;" type="text"/> Acres Percent Imperviousness = <input style="width: 50px;" type="text"/> % NRCS Soil Type = <input style="width: 50px;" type="text"/> A, B, C, or D																																					
Site Type: <input type="radio"/> Site is Urban <input type="radio"/> Site is Non-Urban	Flows Developed For: <input type="radio"/> Street Inlets <input type="radio"/> Area Inlets in a Median	<table border="1" style="display: inline-table; border-collapse: collapse;"> <tr> <td style="padding: 2px;">Slope (ft/ft)</td> <td style="padding: 2px;">Length (ft)</td> </tr> <tr> <td style="padding: 2px;">Overland Flow =</td> <td style="padding: 2px;"></td> </tr> <tr> <td style="padding: 2px;">Channel Flow =</td> <td style="padding: 2px;"></td> </tr> </table>		Slope (ft/ft)	Length (ft)	Overland Flow =		Channel Flow =																															
Slope (ft/ft)	Length (ft)																																						
Overland Flow =																																							
Channel Flow =																																							
Rainfall Information: Intensity I (inch/hr) = $C_1 * P_1 / (C_2 + T_c)^{C_3}$		<table border="1" style="display: inline-table; border-collapse: collapse;"> <tr> <td style="padding: 2px;">Design Storm Return Period, T_r =</td> <td style="padding: 2px;">Minor Storm</td> <td style="padding: 2px;">Major Storm</td> <td style="padding: 2px;">years</td> </tr> <tr> <td style="padding: 2px;">Return Period One-Hour Precipitation, P_1 =</td> <td style="padding: 2px;"></td> <td style="padding: 2px;"></td> <td style="padding: 2px;">inches</td> </tr> <tr> <td style="padding: 2px;">C_1 =</td> <td style="padding: 2px;"></td> <td style="padding: 2px;"></td> <td></td> </tr> <tr> <td style="padding: 2px;">C_2 =</td> <td style="padding: 2px;"></td> <td style="padding: 2px;"></td> <td></td> </tr> <tr> <td style="padding: 2px;">C_3 =</td> <td style="padding: 2px;"></td> <td style="padding: 2px;"></td> <td></td> </tr> <tr> <td style="padding: 2px;">User-Defined Storm Runoff Coefficient (leave this blank to accept a calculated value), C =</td> <td style="padding: 2px;"></td> <td style="padding: 2px;"></td> <td></td> </tr> <tr> <td style="padding: 2px;">User-Defined 5-yr. Runoff Coefficient (leave this blank to accept a calculated value), C_5 =</td> <td style="padding: 2px;"></td> <td style="padding: 2px;"></td> <td></td> </tr> <tr> <td style="padding: 2px;">Bypass (Carry-Over) Flow from upstream Subcatchments, Q_b =</td> <td style="text-align: center;">0.0</td> <td style="text-align: center;">0.0</td> <td style="padding: 2px;">cfs</td> </tr> <tr> <td style="padding: 2px;">Total Design Peak Flow, Q =</td> <td style="text-align: center;">2.6</td> <td style="text-align: center;">6.7</td> <td style="padding: 2px;">cfs</td> </tr> </table>		Design Storm Return Period, T_r =	Minor Storm	Major Storm	years	Return Period One-Hour Precipitation, P_1 =			inches	C_1 =				C_2 =				C_3 =				User-Defined Storm Runoff Coefficient (leave this blank to accept a calculated value), C =				User-Defined 5-yr. Runoff Coefficient (leave this blank to accept a calculated value), C_5 =				Bypass (Carry-Over) Flow from upstream Subcatchments, Q_b =	0.0	0.0	cfs	Total Design Peak Flow, Q =	2.6	6.7	cfs
Design Storm Return Period, T_r =	Minor Storm	Major Storm	years																																				
Return Period One-Hour Precipitation, P_1 =			inches																																				
C_1 =																																							
C_2 =																																							
C_3 =																																							
User-Defined Storm Runoff Coefficient (leave this blank to accept a calculated value), C =																																							
User-Defined 5-yr. Runoff Coefficient (leave this blank to accept a calculated value), C_5 =																																							
Bypass (Carry-Over) Flow from upstream Subcatchments, Q_b =	0.0	0.0	cfs																																				
Total Design Peak Flow, Q =	2.6	6.7	cfs																																				

ALLOWABLE CAPACITY FOR ONE-HALF OF STREET (Minor & Major Storm)

(Based on Regulated Criteria for Maximum Allowable Flow Depth and Spread)

Project: **COMPARK SOUTH**
 Inlet ID: **INLET 6-5A**

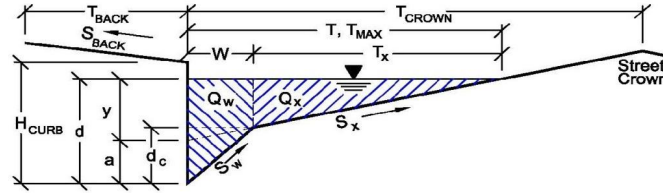

Gutter Geometry (Enter data in the blue cells)													
Maximum Allowable Width for Spread Behind Curb	$T_{BACK} = 0.0$ ft												
Side Slope Behind Curb (leave blank for no conveyance credit behind curb)	$S_{BACK} = 0.020$ ft/ft												
Manning's Roughness Behind Curb (typically between 0.012 and 0.020)	$n_{BACK} = 0.020$												
Height of Curb at Gutter Flow Line	$H_{CURB} = 4.00$ inches												
Distance from Curb Face to Street Crown	$T_{CROWN} = 17.0$ ft												
Gutter Width	$W = 2.00$ ft												
Street Transverse Slope	$S_x = 0.020$ ft/ft												
Gutter Cross Slope (typically 2 inches over 24 inches or 0.083 ft/ft)	$S_w = 0.083$ ft/ft												
Street Longitudinal Slope - Enter 0 for sump condition	$S_o = 0.038$ ft/ft												
Manning's Roughness for Street Section (typically between 0.012 and 0.020)	$n_{STREET} = 0.016$												
Max. Allowable Spread for Minor & Major Storm	<table border="1" style="display: inline-table; border-collapse: collapse;"> <thead> <tr> <th></th> <th>Minor Storm</th> <th>Major Storm</th> <th></th> </tr> </thead> <tbody> <tr> <td>$T_{MAX} =$</td> <td>17.0</td> <td>17.0</td> <td>ft</td> </tr> <tr> <td>$d_{MAX} =$</td> <td>4.0</td> <td>12.0</td> <td>inches</td> </tr> </tbody> </table>		Minor Storm	Major Storm		$T_{MAX} =$	17.0	17.0	ft	$d_{MAX} =$	4.0	12.0	inches
	Minor Storm	Major Storm											
$T_{MAX} =$	17.0	17.0	ft										
$d_{MAX} =$	4.0	12.0	inches										
Max. Allowable Depth at Gutter Flowline for Minor & Major Storm													
Allow Flow Depth at Street Crown (leave blank for no)	<input type="checkbox"/> <input checked="" type="checkbox"/> check = yes												
MINOR STORM Allowable Capacity is based on Depth Criterion													
MAJOR STORM Allowable Capacity is based on Depth Criterion													
Minor storm max. allowable capacity GOOD - greater than flow given on sheet 'Q-Peak'													
Major storm max. allowable capacity GOOD - greater than flow given on sheet 'Q-Peak'													
$Q_{allow} =$	<table border="1" style="display: inline-table; border-collapse: collapse;"> <thead> <tr> <th></th> <th>Minor Storm</th> <th>Major Storm</th> <th></th> </tr> </thead> <tbody> <tr> <td>$Q_{allow} =$</td> <td>6.6</td> <td>88.7</td> <td>cfs</td> </tr> </tbody> </table>		Minor Storm	Major Storm		$Q_{allow} =$	6.6	88.7	cfs				
	Minor Storm	Major Storm											
$Q_{allow} =$	6.6	88.7	cfs										

INLET ON A CONTINUOUS GRADE

Project: COMPARK SOUTH
 Inlet ID: INLET 6-5A

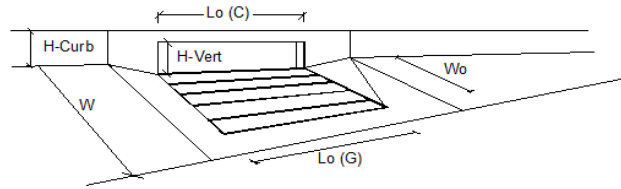

Design Information (Input)	MINOR		MAJOR	
	Type of Inlet	Type = CDOT Type R Curb Opening		
Local Depression (additional to continuous gutter depression 'a' from 'Q-Allow')	a _{LOCAL} = 5.0	5.0	inches	
Total Number of Units in the Inlet (Grate or Curb Opening)	No = 2	2		
Length of a Single Unit Inlet (Grate or Curb Opening)	L _o = 5.00	5.00	ft	
Width of a Unit Grate (cannot be greater than W from Q-Allow)	W _o = N/A	N/A	ft	
Clogging Factor for a Single Unit Grate (typical min. value = 0.5)	C _{r-G} = N/A	N/A		
Clogging Factor for a Single Unit Curb Opening (typical min. value = 0.1)	C _{r-C} = 0.10	0.10		
Street Hydraulics: OK - Q < maximum allowable from sheet 'Q-Allow'				
Total Inlet Interception Capacity	Q = 2.60	6.24	cfs	
Total Inlet Carry-Over Flow (flow bypassing inlet)	Q _b = 0.0	0.5	cfs	
Capture Percentage = Q _a /Q _o =	C% = 100	93	%	

**DESIGN PEAK FLOW FOR ONE-HALF OF STREET
OR GRASS-LINED CHANNEL BY THE RATIONAL METHOD**

Project: COMPARK SOUTH
 Inlet ID: INLET 6-5B

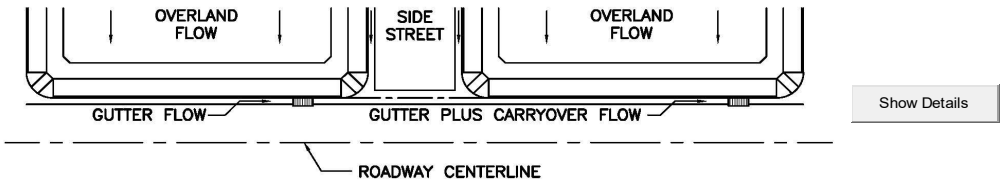

Design Flow: ONLY if already determined through other methods: (local peak flow for 1/2 of street OR grass-lined channel):		<table border="1" style="display: inline-table; border-collapse: collapse;"> <tr> <td style="padding: 2px;">Minor Storm</td> <td style="padding: 2px;">Major Storm</td> </tr> <tr> <td style="text-align: center; padding: 2px;">2.0</td> <td style="text-align: center; padding: 2px;">5.4</td> </tr> </table> cfs	Minor Storm	Major Storm	2.0	5.4	<--- FILL IN THIS SECTION OR... FILL IN THE SECTIONS BELOW. <---																								
Minor Storm	Major Storm																														
2.0	5.4																														
* If you enter values in Row 14, skip the rest of this sheet and proceed to sheet Q-Allow or Area Inlet.																															
Geographic Information: (Enter data in the blue cells):																															
Site Type: <input type="radio"/> Site is Urban <input type="radio"/> Site is Non-Urban	Flows Developed For: <input type="radio"/> Street Inlets <input type="radio"/> Area Inlets in a Median	Subcatchment Area = <input style="width: 50px;" type="text"/> Acres Percent Imperviousness = <input style="width: 50px;" type="text"/> % NRCS Soil Type = <input style="width: 50px;" type="text"/> A, B, C, or D																													
		<table border="1" style="display: inline-table; border-collapse: collapse;"> <tr> <td style="padding: 2px;">Slope (ft/ft)</td> <td style="padding: 2px;">Length (ft)</td> </tr> <tr> <td style="padding: 2px;">Overland Flow = <input style="width: 50px;" type="text"/></td> <td style="padding: 2px;">Channel Flow = <input style="width: 50px;" type="text"/></td> </tr> </table>	Slope (ft/ft)	Length (ft)	Overland Flow = <input style="width: 50px;" type="text"/>	Channel Flow = <input style="width: 50px;" type="text"/>																									
Slope (ft/ft)	Length (ft)																														
Overland Flow = <input style="width: 50px;" type="text"/>	Channel Flow = <input style="width: 50px;" type="text"/>																														
Rainfall Information: Intensity I (inch/hr) = $C_1 * P_1 / (C_2 + T_c)^{C_3}$																															
		<table border="1" style="display: inline-table; border-collapse: collapse;"> <tr> <td style="padding: 2px;">Design Storm Return Period, T_r =</td> <td style="padding: 2px;">Minor Storm</td> <td style="padding: 2px;">Major Storm</td> <td style="padding: 2px;">years</td> </tr> <tr> <td style="padding: 2px;">Return Period One-Hour Precipitation, P_1 =</td> <td style="padding: 2px;"></td> <td style="padding: 2px;"></td> <td style="padding: 2px;">inches</td> </tr> <tr> <td style="padding: 2px;">C_1 =</td> <td style="padding: 2px;"></td> <td style="padding: 2px;"></td> <td style="padding: 2px;"></td> </tr> <tr> <td style="padding: 2px;">C_2 =</td> <td style="padding: 2px;"></td> <td style="padding: 2px;"></td> <td style="padding: 2px;"></td> </tr> <tr> <td style="padding: 2px;">C_3 =</td> <td style="padding: 2px;"></td> <td style="padding: 2px;"></td> <td style="padding: 2px;"></td> </tr> <tr> <td style="padding: 2px;">User-Defined Storm Runoff Coefficient (leave this blank to accept a calculated value), C =</td> <td style="padding: 2px;"></td> <td style="padding: 2px;"></td> <td style="padding: 2px;"></td> </tr> <tr> <td style="padding: 2px;">User-Defined 5-yr. Runoff Coefficient (leave this blank to accept a calculated value), C_5 =</td> <td style="padding: 2px;"></td> <td style="padding: 2px;"></td> <td style="padding: 2px;"></td> </tr> </table>	Design Storm Return Period, T_r =	Minor Storm	Major Storm	years	Return Period One-Hour Precipitation, P_1 =			inches	C_1 =				C_2 =				C_3 =				User-Defined Storm Runoff Coefficient (leave this blank to accept a calculated value), C =				User-Defined 5-yr. Runoff Coefficient (leave this blank to accept a calculated value), C_5 =				
Design Storm Return Period, T_r =	Minor Storm	Major Storm	years																												
Return Period One-Hour Precipitation, P_1 =			inches																												
C_1 =																															
C_2 =																															
C_3 =																															
User-Defined Storm Runoff Coefficient (leave this blank to accept a calculated value), C =																															
User-Defined 5-yr. Runoff Coefficient (leave this blank to accept a calculated value), C_5 =																															
		Bypass (Carry-Over) Flow from upstream Subcatchments, Q_b = <table border="1" style="display: inline-table; border-collapse: collapse;"> <tr> <td style="padding: 2px;">0.0</td> <td style="padding: 2px;">0.0</td> </tr> </table> cfs	0.0	0.0																											
0.0	0.0																														
		Total Design Peak Flow, Q = <table border="1" style="display: inline-table; border-collapse: collapse;"> <tr> <td style="padding: 2px;">2.0</td> <td style="padding: 2px;">5.4</td> </tr> </table> cfs	2.0	5.4																											
2.0	5.4																														

INLET ON A CONTINUOUS GRADE

Project: COMPARK SOUTH
 Inlet ID: INLET 6-5B

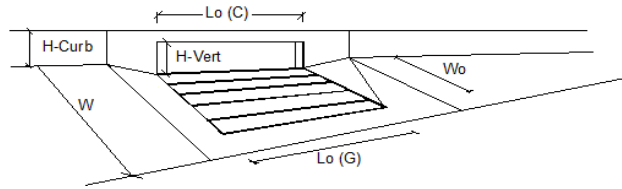

Design Information (Input)	MINOR		MAJOR		
	MINOR	MAJOR	MINOR	MAJOR	
Type of Inlet	CDOT Type R Curb Opening				
Local Depression (additional to continuous gutter depression 'a' from 'Q-Allow')	5.0	5.0	5.0	5.0	inches
Total Number of Units in the Inlet (Grate or Curb Opening)	2	2	2	2	
Length of a Single Unit Inlet (Grate or Curb Opening)	5.00	5.00	5.00	5.00	ft
Width of a Unit Grate (cannot be greater than W from Q-Allow)	N/A	N/A	N/A	N/A	ft
Clogging Factor for a Single Unit Grate (typical min. value = 0.5)	N/A	N/A	N/A	N/A	
Clogging Factor for a Single Unit Curb Opening (typical min. value = 0.1)	0.10	0.10	0.10	0.10	
Street Hydraulics: OK - Q < maximum allowable from sheet 'Q-Allow'					
Total Inlet Interception Capacity	2.00	5.30	2.00	5.30	cfs
Total Inlet Carry-Over Flow (flow bypassing inlet)	0.0	0.1	0.0	0.1	cfs
Capture Percentage = Q_a/Q_b =	100	98	100	98	%

**DESIGN PEAK FLOW FOR ONE-HALF OF STREET
OR GRASS-LINED CHANNEL BY THE RATIONAL METHOD**

Project: COMPARK SOUTH
Inlet ID: INLET 7-5

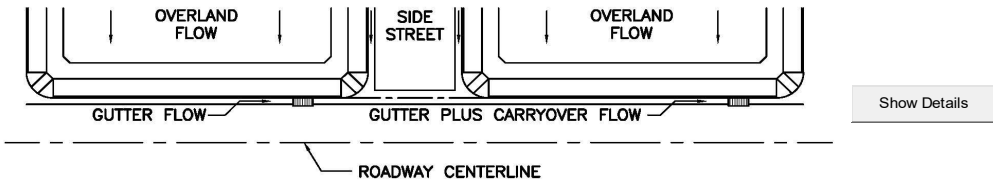

<p>Design Flow: ONLY if already determined through other methods: (local peak flow for 1/2 of street OR grass-lined channel):</p> <p>*Q_{known} = <table border="1" style="display: inline-table;"><tr><td>Minor Storm</td><td>Major Storm</td></tr><tr><td>0.2</td><td>10.2</td></tr></table> cfs</p> <p>* If you enter values in Row 14, skip the rest of this sheet and proceed to sheet Q-Allow or Area Inlet.</p>		Minor Storm	Major Storm	0.2	10.2	<p><--- FILL IN THIS SECTION OR... FILL IN THE SECTIONS BELOW. <---</p>				
Minor Storm	Major Storm									
0.2	10.2									
<p>Geographic Information: (Enter data in the blue cells):</p> <div style="display: flex; justify-content: space-between;"> <div style="width: 45%;"> <p>Site Type:</p> <p><input type="radio"/> Site is Urban</p> <p><input type="radio"/> Site is Non-Urban</p> </div> <div style="width: 45%;"> <p>Flows Developed For:</p> <p><input type="radio"/> Street Inlets</p> <p><input type="radio"/> Area Inlets in a Median</p> </div> </div> <div style="display: flex; justify-content: space-between; margin-top: 10px;"> <div style="width: 45%;"> <p>Subcatchment Area = <input type="text"/> Acres</p> <p>Percent Imperviousness = <input type="text"/> %</p> <p>NRCS Soil Type = <input type="text"/> A, B, C, or D</p> </div> <div style="width: 45%;"> <table border="1" style="width: 100%; border-collapse: collapse;"> <thead> <tr> <th>Slope (ft/ft)</th> <th>Length (ft)</th> </tr> </thead> <tbody> <tr> <td>Overland Flow = <input type="text"/></td> <td><input type="text"/></td> </tr> <tr> <td>Channel Flow = <input type="text"/></td> <td><input type="text"/></td> </tr> </tbody> </table> </div> </div>		Slope (ft/ft)	Length (ft)	Overland Flow = <input type="text"/>	<input type="text"/>	Channel Flow = <input type="text"/>	<input type="text"/>			
Slope (ft/ft)	Length (ft)									
Overland Flow = <input type="text"/>	<input type="text"/>									
Channel Flow = <input type="text"/>	<input type="text"/>									
<p>Rainfall Information: Intensity I (inch/hr) = $C_1 * P_1 / (C_2 + T_c)^{C_3}$</p> <p>Design Storm Return Period, T_r = <input type="text"/> years</p> <p>Return Period One-Hour Precipitation, P_1 = <input type="text"/> inches</p> <p>C_1 = <input type="text"/></p> <p>C_2 = <input type="text"/></p> <p>C_3 = <input type="text"/></p> <p>User-Defined Storm Runoff Coefficient (leave this blank to accept a calculated value), C = <input type="text"/></p> <p>User-Defined 5-yr. Runoff Coefficient (leave this blank to accept a calculated value), C_5 = <input type="text"/></p> <p>Bypass (Carry-Over) Flow from upstream Subcatchments, Q_b = <table border="1" style="display: inline-table;"><tr><td>Minor Storm</td><td>Major Storm</td></tr><tr><td>0.0</td><td>0.0</td></tr></table> cfs</p> <p style="text-align: center;">Total Design Peak Flow, Q = <table border="1" style="display: inline-table;"><tr><td>Minor Storm</td><td>Major Storm</td></tr><tr><td>0.2</td><td>10.2</td></tr></table> cfs</p>		Minor Storm	Major Storm	0.0	0.0	Minor Storm	Major Storm	0.2	10.2	
Minor Storm	Major Storm									
0.0	0.0									
Minor Storm	Major Storm									
0.2	10.2									

AREA INLET IN A TRAPEZOIDAL GRASS-LINED CHANNEL

COMPARK SOUTH
INLET 7-5

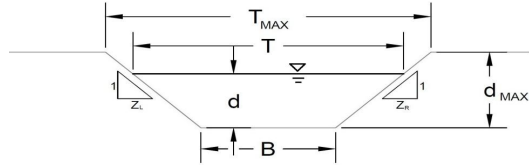

Grass Type	Limiting Manning's n
A	0.06
B	0.04
C	0.033
D	0.03
E	0.024

Analysis of Trapezoidal Grass-Lined Channel Using SCS Method

NRCS Vegetal Retardance (A, B, C, D, or E)
Manning's n (Leave cell D16 blank to manually enter an n value)
Channel Invert Slope
Bottom Width
Left Side Slope
Right Side Slope

A, B, C, D or E
n = 0.030
S₀ = 0.0100 ft/ft
B = 2.00 ft
Z1 = 5.00 ft/ft
Z2 = 5.00 ft/ft

Check one of the following soil types:

Soil Type:	Max. Velocity (V _{MAX})	Max Froude No. (F _{MAX})
Sandy	5.0 fps	0.50
Non-Sandy	7.0 fps	0.80

Choose One:
 Sandy
 Non-Sandy

Max. Allowable Top Width of Channel for Minor & Major Storm
Max. Allowable Water Depth in Channel for Minor & Major Storm

	Minor Storm	Major Storm	
T _{MAX} =	12.00	12.00	feet
d _{MAX} =	1.00	1.00	feet

Allowable Channel Capacity Based On Channel Geometry

MINOR STORM Allowable Capacity is based on Depth Criterion
MAJOR STORM Allowable Capacity is based on Depth Criterion

	Minor Storm	Major Storm	
Q _{allow} =	24.01	24.01	cfs
d _{allow} =	1.00	1.00	ft

Water Depth in Channel Based On Design Peak Flow

Design Peak Flow
Water Depth

Q _p =	0.20	10.20	cfs
d =	0.09	0.68	feet

Minor storm max. allowable capacity GOOD - greater than flow given on sheet 'Q-Peak'
Major storm max. allowable capacity GOOD - greater than flow given on sheet 'Q-Peak'

AREA INLET IN A TRAPEZOIDAL GRASS-LINED CHANNEL

COMPARK SOUTH
INLET 7-5

Inlet Design Information (Input)

Type of Inlet

Inlet Type = CDOT Type C

Angle of Inclined Gate (must be ≤ 30 degrees)

$\theta =$ 0.00 degrees

Width of Gate

$W =$ 3.00 feet

Length of Gate

$L =$ 3.00 feet

Open Area Ratio

$A_{RATIO} =$ 0.70

Height of Inclined Gate

$H_B =$ 0.00 feet

Clogging Factor

$C_f =$ 0.50

Grate Discharge Coefficient

$C_d =$ 0.96

Orifice Coefficient

$C_o =$ 0.64

Weir Coefficient

$C_w =$ 2.05

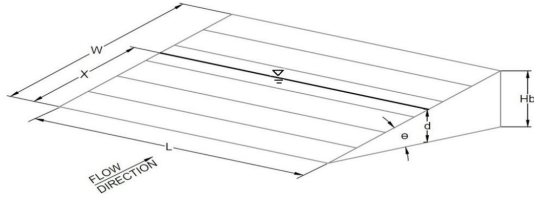

Water Depth at Inlet (for depressed inlets, 1 foot is added for depression)

	MINOR	MAJOR
$d =$	0.09	0.68

Total Inlet Interception Capacity (assumes clogged condition)

	MINOR	MAJOR	
$Q_a =$	0.51	10.44	cfs

Inlet Capacity IS GOOD for Minor and Major Storms ($> Q_{PEAK}$)

Bypassed Flow, $Q_b =$ 0.00 0.00 cfs

Capture Percentage = $Q_a/Q_o = C\%$ 100 100 %

**DESIGN PEAK FLOW FOR ONE-HALF OF STREET
OR GRASS-LINED CHANNEL BY THE RATIONAL METHOD**

Project: COMPARK SOUTH
 Inlet ID: INLET 2-10

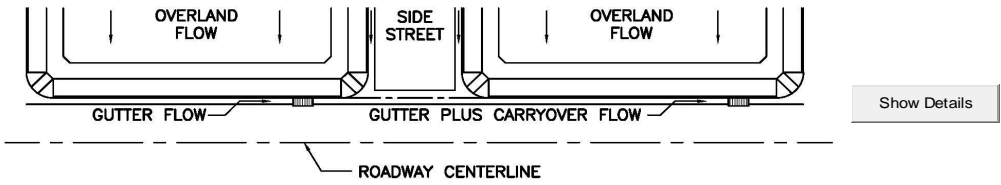

<p>Design Flow: ONLY if already determined through other methods: (local peak flow for 1/2 of street OR grass-lined channel):</p>		<table border="1" style="display: inline-table; border-collapse: collapse;"> <tr> <td style="padding: 2px;">Minor Storm</td> <td style="padding: 2px;">Major Storm</td> </tr> <tr> <td style="text-align: center;">2.7</td> <td style="text-align: center;">6.1</td> </tr> </table> cfs	Minor Storm	Major Storm	2.7	6.1	<--- FILL IN THIS SECTION OR... FILL IN THE SECTIONS BELOW. <---																								
Minor Storm	Major Storm																														
2.7	6.1																														
<p>* If you enter values in Row 14, skip the rest of this sheet and proceed to sheet Q-Allow or Area Inlet.</p>																															
<p>Geographic Information: (Enter data in the blue cells):</p>																															
Site Type: <input type="radio"/> Site is Urban <input type="radio"/> Site is Non-Urban	Flows Developed For: <input type="radio"/> Street Inlets <input type="radio"/> Area Inlets in a Median	Subcatchment Area = <input type="text"/> Acres Percent Imperviousness = <input type="text"/> % NRCS Soil Type = <input type="text"/> A, B, C, or D																													
		<table border="1" style="display: inline-table; border-collapse: collapse;"> <tr> <td style="padding: 2px;">Slope (ft/ft)</td> <td style="padding: 2px;">Length (ft)</td> </tr> <tr> <td style="text-align: center;">Overland Flow = <input type="text"/></td> <td style="text-align: center;">Channel Flow = <input type="text"/></td> </tr> </table>	Slope (ft/ft)	Length (ft)	Overland Flow = <input type="text"/>	Channel Flow = <input type="text"/>																									
Slope (ft/ft)	Length (ft)																														
Overland Flow = <input type="text"/>	Channel Flow = <input type="text"/>																														
<p>Rainfall Information: Intensity I (inch/hr) = $C_1 * P_1 / (C_2 + I_c)^{C_3}$</p>																															
		<table border="1" style="display: inline-table; border-collapse: collapse;"> <tr> <td style="padding: 2px;">Design Storm Return Period, T_r =</td> <td style="padding: 2px;">Minor Storm</td> <td style="padding: 2px;">Major Storm</td> <td style="padding: 2px;">years</td> </tr> <tr> <td style="padding: 2px;">Return Period One-Hour Precipitation, P_1 =</td> <td style="padding: 2px;"></td> <td style="padding: 2px;"></td> <td style="padding: 2px;">inches</td> </tr> <tr> <td style="padding: 2px;">C_1 =</td> <td style="padding: 2px;"></td> <td style="padding: 2px;"></td> <td style="padding: 2px;"></td> </tr> <tr> <td style="padding: 2px;">C_2 =</td> <td style="padding: 2px;"></td> <td style="padding: 2px;"></td> <td style="padding: 2px;"></td> </tr> <tr> <td style="padding: 2px;">C_3 =</td> <td style="padding: 2px;"></td> <td style="padding: 2px;"></td> <td style="padding: 2px;"></td> </tr> <tr> <td style="padding: 2px;">User-Defined Storm Runoff Coefficient (leave this blank to accept a calculated value), C =</td> <td style="padding: 2px;"></td> <td style="padding: 2px;"></td> <td style="padding: 2px;"></td> </tr> <tr> <td style="padding: 2px;">User-Defined 5-yr. Runoff Coefficient (leave this blank to accept a calculated value), C_5 =</td> <td style="padding: 2px;"></td> <td style="padding: 2px;"></td> <td style="padding: 2px;"></td> </tr> </table>	Design Storm Return Period, T_r =	Minor Storm	Major Storm	years	Return Period One-Hour Precipitation, P_1 =			inches	C_1 =				C_2 =				C_3 =				User-Defined Storm Runoff Coefficient (leave this blank to accept a calculated value), C =				User-Defined 5-yr. Runoff Coefficient (leave this blank to accept a calculated value), C_5 =				
Design Storm Return Period, T_r =	Minor Storm	Major Storm	years																												
Return Period One-Hour Precipitation, P_1 =			inches																												
C_1 =																															
C_2 =																															
C_3 =																															
User-Defined Storm Runoff Coefficient (leave this blank to accept a calculated value), C =																															
User-Defined 5-yr. Runoff Coefficient (leave this blank to accept a calculated value), C_5 =																															
		Bypass (Carry-Over) Flow from upstream Subcatchments, Q_b = <table border="1" style="display: inline-table; border-collapse: collapse;"><tr><td style="padding: 2px;">0.0</td><td style="padding: 2px;">0.5</td></tr></table> cfs	0.0	0.5																											
0.0	0.5																														
		Total Design Peak Flow, Q = <table border="1" style="display: inline-table; border-collapse: collapse;"><tr><td style="padding: 2px;">2.7</td><td style="padding: 2px;">6.6</td></tr></table> cfs	2.7	6.6																											
2.7	6.6																														

INLET ON A CONTINUOUS GRADE

Project: COMPARK SOUTH
 Inlet ID: INLET 2-10

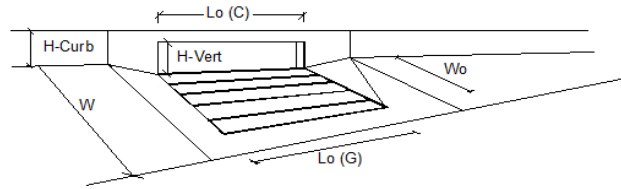

Design Information (Input)	MINOR		MAJOR	
	Type of Inlet	Type = CDOT Type R Curb Opening		
Local Depression (additional to continuous gutter depression 'a' from 'Q-Allow')	$a_{LOCAL} = 5.0$	5.0	inches	
Total Number of Units in the Inlet (Grate or Curb Opening)	$N_o = 2$	2		
Length of a Single Unit Inlet (Grate or Curb Opening)	$L_o = 5.00$	5.00	ft	
Width of a Unit Grate (cannot be greater than W from Q-Allow)	$W_o = N/A$	N/A	ft	
Clogging Factor for a Single Unit Grate (typical min. value = 0.5)	$C_r-G = N/A$	N/A		
Clogging Factor for a Single Unit Curb Opening (typical min. value = 0.1)	$C_r-C = 0.10$	0.10		
Street Hydraulics: OK - Q < maximum allowable from sheet 'Q-Allow'				
Total Inlet Interception Capacity	$Q = 2.70$	6.11	cfs	
Total Inlet Carry-Over Flow (flow bypassing inlet)	$Q_b = 0.0$	0.5	cfs	
Capture Percentage = $Q_a/Q_o =$	$C\% = 100$	93	%	

**DESIGN PEAK FLOW FOR ONE-HALF OF STREET
OR GRASS-LINED CHANNEL BY THE RATIONAL METHOD**

Project: COMPARK SOUTH
 Inlet ID: INLET 2-10A

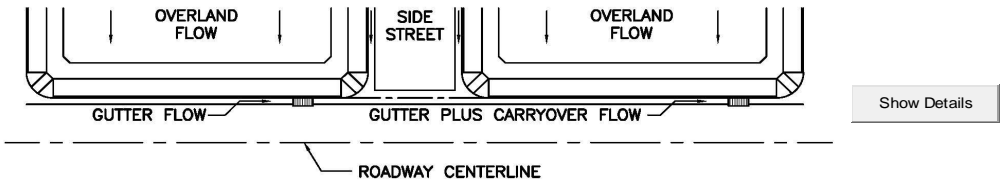

Design Flow: ONLY if already determined through other methods: (local peak flow for 1/2 of street OR grass-lined channel):		<table border="1" style="display: inline-table; border-collapse: collapse;"> <tr> <td style="padding: 2px;">Minor Storm</td> <td style="padding: 2px;">Major Storm</td> </tr> <tr> <td style="text-align: center; padding: 2px;">1.9</td> <td style="text-align: center; padding: 2px;">5.2</td> </tr> </table> cfs	Minor Storm	Major Storm	1.9	5.2	<--- FILL IN THIS SECTION OR... FILL IN THE SECTIONS BELOW. <---
Minor Storm	Major Storm						
1.9	5.2						
* If you enter values in Row 14, skip the rest of this sheet and proceed to sheet Q-Allow or Area Inlet.							
Geographic Information: (Enter data in the blue cells):							
Site Type:	Flows Developed For:	Subcatchment Area = <input style="width: 50px;" type="text"/> Acres					
<input type="radio"/> Site is Urban	<input type="radio"/> Street Inlets	Percent Imperviousness = <input style="width: 50px;" type="text"/> %					
<input type="radio"/> Site is Non-Urban	<input type="radio"/> Area Inlets in a Median	NRCS Soil Type = <input style="width: 50px;" type="text"/> A, B, C, or D					
		Slope (ft/ft) Length (ft)					
		Overland Flow = <input style="width: 50px;" type="text"/>					
		Channel Flow = <input style="width: 50px;" type="text"/>					
Rainfall Information: Intensity I (inch/hr) = $C_1 * P_1 / (C_2 + T_c)^{C_3}$							
	Design Storm Return Period, T_r =	<table border="1" style="display: inline-table; border-collapse: collapse;"> <tr> <td style="padding: 2px;">Minor Storm</td> <td style="padding: 2px;">Major Storm</td> </tr> <tr> <td style="padding: 2px;"> </td> <td style="padding: 2px;"> </td> </tr> </table> years	Minor Storm	Major Storm			
Minor Storm	Major Storm						
	Return Period One-Hour Precipitation, P_1 =	<table border="1" style="display: inline-table; border-collapse: collapse;"> <tr> <td style="padding: 2px;"> </td> <td style="padding: 2px;"> </td> </tr> </table> inches					
	C_1 =	<table border="1" style="display: inline-table; border-collapse: collapse;"> <tr> <td style="padding: 2px;"> </td> <td style="padding: 2px;"> </td> </tr> </table>					
	C_2 =	<table border="1" style="display: inline-table; border-collapse: collapse;"> <tr> <td style="padding: 2px;"> </td> <td style="padding: 2px;"> </td> </tr> </table>					
	C_3 =	<table border="1" style="display: inline-table; border-collapse: collapse;"> <tr> <td style="padding: 2px;"> </td> <td style="padding: 2px;"> </td> </tr> </table>					
	User-Defined Storm Runoff Coefficient (leave this blank to accept a calculated value), C =	<table border="1" style="display: inline-table; border-collapse: collapse;"> <tr> <td style="padding: 2px;"> </td> <td style="padding: 2px;"> </td> </tr> </table>					
	User-Defined 5-yr. Runoff Coefficient (leave this blank to accept a calculated value), C_5 =	<table border="1" style="display: inline-table; border-collapse: collapse;"> <tr> <td style="padding: 2px;"> </td> <td style="padding: 2px;"> </td> </tr> </table>					
	Bypass (Carry-Over) Flow from upstream Subcatchments, Q_b =	<table border="1" style="display: inline-table; border-collapse: collapse;"> <tr> <td style="padding: 2px;">0.0</td> <td style="padding: 2px;">0.3</td> </tr> </table> cfs	0.0	0.3			
0.0	0.3						
	Total Design Peak Flow, Q =	<table border="1" style="display: inline-table; border-collapse: collapse;"> <tr> <td style="padding: 2px;">1.9</td> <td style="padding: 2px;">5.5</td> </tr> </table> cfs	1.9	5.5			
1.9	5.5						

ALLOWABLE CAPACITY FOR ONE-HALF OF STREET (Minor & Major Storm)

(Based on Regulated Criteria for Maximum Allowable Flow Depth and Spread)

Project: **COMPARK SOUTH**

Inlet ID: **INLET 2-10A**

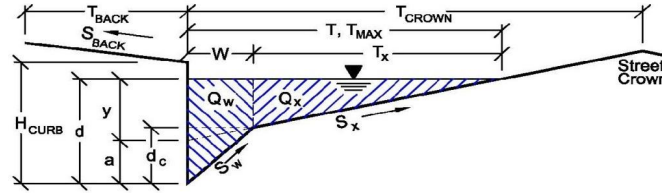

Gutter Geometry (Enter data in the blue cells)							
Maximum Allowable Width for Spread Behind Curb	$T_{BACK} = $ <input style="width: 50px;" type="text" value="0.0"/> ft						
Side Slope Behind Curb (leave blank for no conveyance credit behind curb)	$S_{BACK} = $ <input style="width: 50px;" type="text" value="0.020"/> ft/ft						
Manning's Roughness Behind Curb (typically between 0.012 and 0.020)	$n_{BACK} = $ <input style="width: 50px;" type="text" value="0.020"/>						
Height of Curb at Gutter Flow Line	$H_{CURB} = $ <input style="width: 50px;" type="text" value="4.00"/> inches						
Distance from Curb Face to Street Crown	$T_{CROWN} = $ <input style="width: 50px;" type="text" value="17.0"/> ft						
Gutter Width	$W = $ <input style="width: 50px;" type="text" value="2.00"/> ft						
Street Transverse Slope	$S_x = $ <input style="width: 50px;" type="text" value="0.021"/> ft/ft						
Gutter Cross Slope (typically 2 inches over 24 inches or 0.083 ft/ft)	$S_w = $ <input style="width: 50px;" type="text" value="0.083"/> ft/ft						
Street Longitudinal Slope - Enter 0 for sump condition	$S_o = $ <input style="width: 50px;" type="text" value="0.010"/> ft/ft						
Manning's Roughness for Street Section (typically between 0.012 and 0.020)	$n_{STREET} = $ <input style="width: 50px;" type="text" value="0.016"/>						
Max. Allowable Spread for Minor & Major Storm	<table border="1" style="display: inline-table; border-collapse: collapse;"> <thead> <tr> <th style="padding: 2px;">Minor Storm</th> <th style="padding: 2px;">Major Storm</th> <th style="padding: 2px;">ft</th> </tr> </thead> <tbody> <tr> <td style="text-align: center;"><input style="width: 40px;" type="text" value="17.0"/></td> <td style="text-align: center;"><input style="width: 40px;" type="text" value="17.0"/></td> <td></td> </tr> </tbody> </table>	Minor Storm	Major Storm	ft	<input style="width: 40px;" type="text" value="17.0"/>	<input style="width: 40px;" type="text" value="17.0"/>	
Minor Storm	Major Storm	ft					
<input style="width: 40px;" type="text" value="17.0"/>	<input style="width: 40px;" type="text" value="17.0"/>						
Max. Allowable Depth at Gutter Flowline for Minor & Major Storm	<table border="1" style="display: inline-table; border-collapse: collapse;"> <thead> <tr> <th style="padding: 2px;">Minor Storm</th> <th style="padding: 2px;">Major Storm</th> <th style="padding: 2px;">inches</th> </tr> </thead> <tbody> <tr> <td style="text-align: center;"><input style="width: 40px;" type="text" value="4.0"/></td> <td style="text-align: center;"><input style="width: 40px;" type="text" value="12.0"/></td> <td></td> </tr> </tbody> </table>	Minor Storm	Major Storm	inches	<input style="width: 40px;" type="text" value="4.0"/>	<input style="width: 40px;" type="text" value="12.0"/>	
Minor Storm	Major Storm	inches					
<input style="width: 40px;" type="text" value="4.0"/>	<input style="width: 40px;" type="text" value="12.0"/>						
Allow Flow Depth at Street Crown (leave blank for no)	<input type="checkbox"/> <input type="checkbox"/> check = yes						
MINOR STORM Allowable Capacity is based on Depth Criterion							
MAJOR STORM Allowable Capacity is based on Spread Criterion							
<div style="color: red; font-weight: bold; font-size: small;"> Minor storm max. allowable capacity GOOD - greater than flow given on sheet 'Q-Peak' Major storm max. allowable capacity GOOD - greater than flow given on sheet 'Q-Peak' </div>	<table border="1" style="display: inline-table; border-collapse: collapse;"> <thead> <tr> <th style="padding: 2px;">Minor Storm</th> <th style="padding: 2px;">Major Storm</th> <th style="padding: 2px;">cfs</th> </tr> </thead> <tbody> <tr> <td style="text-align: center;"><input style="width: 40px;" type="text" value="3.3"/></td> <td style="text-align: center;"><input style="width: 40px;" type="text" value="11.6"/></td> <td></td> </tr> </tbody> </table>	Minor Storm	Major Storm	cfs	<input style="width: 40px;" type="text" value="3.3"/>	<input style="width: 40px;" type="text" value="11.6"/>	
Minor Storm	Major Storm	cfs					
<input style="width: 40px;" type="text" value="3.3"/>	<input style="width: 40px;" type="text" value="11.6"/>						

INLET ON A CONTINUOUS GRADE

Project: COMPARK SOUTH
 Inlet ID: INLET 2-10A

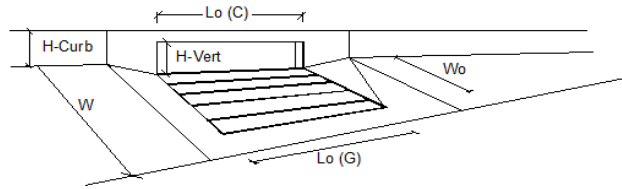

Design Information (Input)	MINOR		MAJOR	
	Type of Inlet	Type = CDOT Type R Curb Opening		
Local Depression (additional to continuous gutter depression 'a' from 'Q-Allow')	$a_{LOCAL} = 5.0$	5.0	inches	
Total Number of Units in the Inlet (Grate or Curb Opening)	$N_o = 2$	2		
Length of a Single Unit Inlet (Grate or Curb Opening)	$L_o = 5.00$	5.00	ft	
Width of a Unit Grate (cannot be greater than W from Q-Allow)	$W_o = N/A$	N/A	ft	
Clogging Factor for a Single Unit Grate (typical min. value = 0.5)	$C_r-G = N/A$	N/A		
Clogging Factor for a Single Unit Curb Opening (typical min. value = 0.1)	$C_r-C = 0.10$	0.10		
Street Hydraulics: OK - Q < maximum allowable from sheet 'Q-Allow'				
Total Inlet Interception Capacity	$Q = 1.90$	5.35	cfs	
Total Inlet Carry-Over Flow (flow bypassing inlet)	$Q_b = 0.0$	0.2	cfs	
Capture Percentage = $Q_a/Q_o =$	$C\% = 100$	97	%	

**DESIGN PEAK FLOW FOR ONE-HALF OF STREET
OR GRASS-LINED CHANNEL BY THE RATIONAL METHOD**

Project: COMPARK SOUTH
 Inlet ID: INLET 2-11

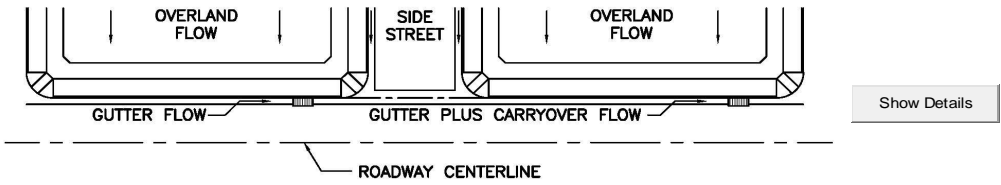

<p>Design Flow: ONLY if already determined through other methods: (local peak flow for 1/2 of street OR grass-lined channel):</p>		<table border="1" style="display: inline-table; border-collapse: collapse;"> <tr> <td style="padding: 2px;">Minor Storm</td> <td style="padding: 2px;">Major Storm</td> </tr> <tr> <td style="text-align: center; padding: 2px;">1.9</td> <td style="text-align: center; padding: 2px;">7.8</td> </tr> </table> cfs	Minor Storm	Major Storm	1.9	7.8	<--- FILL IN THIS SECTION OR... FILL IN THE SECTIONS BELOW. <---												
Minor Storm	Major Storm																		
1.9	7.8																		
<p>* If you enter values in Row 14, skip the rest of this sheet and proceed to sheet Q-Allow or Area Inlet.</p>																			
<p>Geographic Information: (Enter data in the blue cells):</p>																			
<p>Site Type:</p> <p><input type="radio"/> Site is Urban</p> <p><input type="radio"/> Site is Non-Urban</p>	<p>Flows Developed For:</p> <p><input type="radio"/> Street Inlets</p> <p><input type="radio"/> Area Inlets in a Median</p>	<p>Subcatchment Area = <input style="width: 50px;" type="text"/> Acres</p> <p>Percent Imperviousness = <input style="width: 50px;" type="text"/> %</p> <p>NRCS Soil Type = <input style="width: 50px;" type="text"/> A, B, C, or D</p>	<table border="1" style="display: inline-table; border-collapse: collapse;"> <tr> <td style="padding: 2px;">Slope (ft/ft)</td> <td style="padding: 2px;">Length (ft)</td> </tr> <tr> <td style="padding: 2px;">Overland Flow = <input style="width: 50px;" type="text"/></td> <td style="padding: 2px;"><input style="width: 50px;" type="text"/></td> </tr> <tr> <td style="padding: 2px;">Channel Flow = <input style="width: 50px;" type="text"/></td> <td style="padding: 2px;"><input style="width: 50px;" type="text"/></td> </tr> </table>	Slope (ft/ft)	Length (ft)	Overland Flow = <input style="width: 50px;" type="text"/>	<input style="width: 50px;" type="text"/>	Channel Flow = <input style="width: 50px;" type="text"/>	<input style="width: 50px;" type="text"/>										
Slope (ft/ft)	Length (ft)																		
Overland Flow = <input style="width: 50px;" type="text"/>	<input style="width: 50px;" type="text"/>																		
Channel Flow = <input style="width: 50px;" type="text"/>	<input style="width: 50px;" type="text"/>																		
<p>Rainfall Information: Intensity I (inch/hr) = $C_1 * P_1 / (C_2 + T_c) ^{C_3}$</p>																			
		<table border="1" style="display: inline-table; border-collapse: collapse;"> <tr> <td style="padding: 2px;">Minor Storm</td> <td style="padding: 2px;">Major Storm</td> </tr> <tr> <td style="padding: 2px;">Design Storm Return Period, T_r = <input style="width: 50px;" type="text"/></td> <td style="padding: 2px;"><input style="width: 50px;" type="text"/></td> </tr> <tr> <td style="padding: 2px;">Return Period One-Hour Precipitation, P_1 = <input style="width: 50px;" type="text"/></td> <td style="padding: 2px;"><input style="width: 50px;" type="text"/></td> </tr> <tr> <td style="padding: 2px;">C_1 = <input style="width: 50px;" type="text"/></td> <td style="padding: 2px;"><input style="width: 50px;" type="text"/></td> </tr> <tr> <td style="padding: 2px;">C_2 = <input style="width: 50px;" type="text"/></td> <td style="padding: 2px;"><input style="width: 50px;" type="text"/></td> </tr> <tr> <td style="padding: 2px;">C_3 = <input style="width: 50px;" type="text"/></td> <td style="padding: 2px;"><input style="width: 50px;" type="text"/></td> </tr> <tr> <td style="padding: 2px;">User-Defined Storm Runoff Coefficient (leave this blank to accept a calculated value), C = <input style="width: 50px;" type="text"/></td> <td style="padding: 2px;"><input style="width: 50px;" type="text"/></td> </tr> <tr> <td style="padding: 2px;">User-Defined 5-yr. Runoff Coefficient (leave this blank to accept a calculated value), C_5 = <input style="width: 50px;" type="text"/></td> <td style="padding: 2px;"><input style="width: 50px;" type="text"/></td> </tr> </table>	Minor Storm	Major Storm	Design Storm Return Period, T_r = <input style="width: 50px;" type="text"/>	<input style="width: 50px;" type="text"/>	Return Period One-Hour Precipitation, P_1 = <input style="width: 50px;" type="text"/>	<input style="width: 50px;" type="text"/>	C_1 = <input style="width: 50px;" type="text"/>	<input style="width: 50px;" type="text"/>	C_2 = <input style="width: 50px;" type="text"/>	<input style="width: 50px;" type="text"/>	C_3 = <input style="width: 50px;" type="text"/>	<input style="width: 50px;" type="text"/>	User-Defined Storm Runoff Coefficient (leave this blank to accept a calculated value), C = <input style="width: 50px;" type="text"/>	<input style="width: 50px;" type="text"/>	User-Defined 5-yr. Runoff Coefficient (leave this blank to accept a calculated value), C_5 = <input style="width: 50px;" type="text"/>	<input style="width: 50px;" type="text"/>	years inches
Minor Storm	Major Storm																		
Design Storm Return Period, T_r = <input style="width: 50px;" type="text"/>	<input style="width: 50px;" type="text"/>																		
Return Period One-Hour Precipitation, P_1 = <input style="width: 50px;" type="text"/>	<input style="width: 50px;" type="text"/>																		
C_1 = <input style="width: 50px;" type="text"/>	<input style="width: 50px;" type="text"/>																		
C_2 = <input style="width: 50px;" type="text"/>	<input style="width: 50px;" type="text"/>																		
C_3 = <input style="width: 50px;" type="text"/>	<input style="width: 50px;" type="text"/>																		
User-Defined Storm Runoff Coefficient (leave this blank to accept a calculated value), C = <input style="width: 50px;" type="text"/>	<input style="width: 50px;" type="text"/>																		
User-Defined 5-yr. Runoff Coefficient (leave this blank to accept a calculated value), C_5 = <input style="width: 50px;" type="text"/>	<input style="width: 50px;" type="text"/>																		
		<table border="1" style="display: inline-table; border-collapse: collapse;"> <tr> <td style="padding: 2px;">Bypass (Carry-Over) Flow from upstream Subcatchments, Q_b = <input style="width: 50px;" type="text"/></td> <td style="padding: 2px;"><input style="width: 50px;" type="text"/></td> </tr> <tr> <td style="padding: 2px;"></td> <td style="padding: 2px;"></td> </tr> </table> cfs	Bypass (Carry-Over) Flow from upstream Subcatchments, Q_b = <input style="width: 50px;" type="text"/>	<input style="width: 50px;" type="text"/>															
Bypass (Carry-Over) Flow from upstream Subcatchments, Q_b = <input style="width: 50px;" type="text"/>	<input style="width: 50px;" type="text"/>																		
		<table border="1" style="display: inline-table; border-collapse: collapse;"> <tr> <td style="padding: 2px;">Total Design Peak Flow, Q = <input style="width: 50px;" type="text"/></td> <td style="padding: 2px;"><input style="width: 50px;" type="text"/></td> </tr> <tr> <td style="padding: 2px;"></td> <td style="padding: 2px;"></td> </tr> </table> cfs	Total Design Peak Flow, Q = <input style="width: 50px;" type="text"/>	<input style="width: 50px;" type="text"/>															
Total Design Peak Flow, Q = <input style="width: 50px;" type="text"/>	<input style="width: 50px;" type="text"/>																		

ALLOWABLE CAPACITY FOR ONE-HALF OF STREET (Minor & Major Storm)

(Based on Regulated Criteria for Maximum Allowable Flow Depth and Spread)

Project: COMPARK SOUTH
 Inlet ID: INLET 2-11

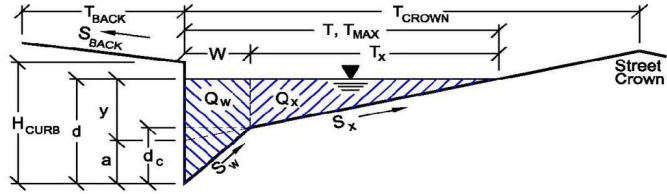

Gutter Geometry (Enter data in the blue cells)						
Maximum Allowable Width for Spread Behind Curb	$T_{BACK} =$	0.0 ft				
Side Slope Behind Curb (leave blank for no conveyance credit behind curb)	$S_{BACK} =$	0.020 ft/ft				
Manning's Roughness Behind Curb (typically between 0.012 and 0.020)	$n_{BACK} =$	0.020				
Height of Curb at Gutter Flow Line	$H_{CURB} =$	4.00 inches				
Distance from Curb Face to Street Crown	$T_{CROWN} =$	17.0 ft				
Gutter Width	$W =$	2.00 ft				
Street Transverse Slope	$S_x =$	0.021 ft/ft				
Gutter Cross Slope (typically 2 inches over 24 inches or 0.083 ft/ft)	$S_w =$	0.083 ft/ft				
Street Longitudinal Slope - Enter 0 for sump condition	$S_o =$	0.010 ft/ft				
Manning's Roughness for Street Section (typically between 0.012 and 0.020)	$n_{STREET} =$	0.016				
Max. Allowable Spread for Minor & Major Storm	$T_{MAX} =$	<table border="1" style="display: inline-table; border-collapse: collapse;"> <thead> <tr> <th style="padding: 2px;">Minor Storm</th> <th style="padding: 2px;">Major Storm</th> </tr> </thead> <tbody> <tr> <td style="padding: 2px; text-align: center;">17.0</td> <td style="padding: 2px; text-align: center;">17.0</td> </tr> </tbody> </table> ft	Minor Storm	Major Storm	17.0	17.0
Minor Storm	Major Storm					
17.0	17.0					
Max. Allowable Depth at Gutter Flowline for Minor & Major Storm	$d_{MAX} =$	<table border="1" style="display: inline-table; border-collapse: collapse;"> <thead> <tr> <th style="padding: 2px;">Minor Storm</th> <th style="padding: 2px;">Major Storm</th> </tr> </thead> <tbody> <tr> <td style="padding: 2px; text-align: center;">4.0</td> <td style="padding: 2px; text-align: center;">12.0</td> </tr> </tbody> </table> inches	Minor Storm	Major Storm	4.0	12.0
Minor Storm	Major Storm					
4.0	12.0					
Allow Flow Depth at Street Crown (leave blank for no)		<input type="checkbox"/> <input type="checkbox"/> check = yes				
MINOR STORM Allowable Capacity is based on Depth Criterion						
MAJOR STORM Allowable Capacity is based on Spread Criterion	$Q_{allow} =$	<table border="1" style="display: inline-table; border-collapse: collapse;"> <thead> <tr> <th style="padding: 2px;">Minor Storm</th> <th style="padding: 2px;">Major Storm</th> </tr> </thead> <tbody> <tr> <td style="padding: 2px; text-align: center;">3.3</td> <td style="padding: 2px; text-align: center;">11.6</td> </tr> </tbody> </table> cfs	Minor Storm	Major Storm	3.3	11.6
Minor Storm	Major Storm					
3.3	11.6					
Minor storm max. allowable capacity GOOD - greater than flow given on sheet 'Q-Peak'						
Major storm max. allowable capacity GOOD - greater than flow given on sheet 'Q-Peak'						

INLET ON A CONTINUOUS GRADE

Project: COMPARK SOUTH
 Inlet ID: INLET 2-11

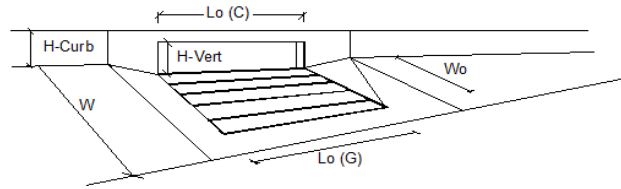

Design Information (Input)	MINOR		MAJOR	
	Type of Inlet	Type = CDOT Type R Curb Opening		
Local Depression (additional to continuous gutter depression 'a' from 'Q-Allow')	$a_{LOCAL} = 5.0$	5.0	inches	
Total Number of Units in the Inlet (Grate or Curb Opening)	$N_o = 2$	2		
Length of a Single Unit Inlet (Grate or Curb Opening)	$L_o = 5.00$	5.00	ft	
Width of a Unit Grate (cannot be greater than W from Q-Allow)	$W_o = N/A$	N/A	ft	
Clogging Factor for a Single Unit Grate (typical min. value = 0.5)	$C_r-G = N/A$	N/A		
Clogging Factor for a Single Unit Curb Opening (typical min. value = 0.1)	$C_r-C = 0.10$	0.10		
Street Hydraulics: OK - Q < maximum allowable from sheet 'Q-Allow'				
Total Inlet Interception Capacity	$Q = 1.90$	6.82	cfs	
Total Inlet Carry-Over Flow (flow bypassing inlet)	$Q_b = 0.0$	1.0	cfs	
Capture Percentage = $Q_a/Q_o =$	$C\% = 100$	87	%	

**DESIGN PEAK FLOW FOR ONE-HALF OF STREET
OR GRASS-LINED CHANNEL BY THE RATIONAL METHOD**

Project: COMPARK SOUTH
 Inlet ID: INLET 2-11A

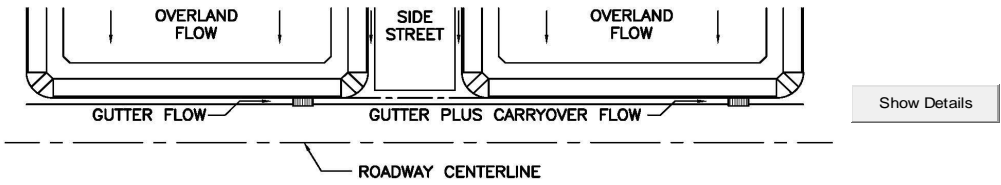

Design Flow: ONLY if already determined through other methods: (local peak flow for 1/2 of street OR grass-lined channel):		Minor Storm Major Storm *Q _{known} = <input type="text" value="2.5"/> <input type="text" value="7.0"/> cfs	<--- FILL IN THIS SECTION OR... FILL IN THE SECTIONS BELOW. <---
Geographic Information: (Enter data in the blue cells):		Subcatchment Area = <input type="text"/> Acres Percent Imperviousness = <input type="text"/> % NRCS Soil Type = <input type="text"/> A, B, C, or D	
Site Type: <input type="radio"/> Site is Urban <input type="radio"/> Site is Non-Urban	Flows Developed For: <input type="radio"/> Street Inlets <input type="radio"/> Area Inlets in a Median	Slope (ft/ft) Length (ft) Overland Flow = <input type="text"/> <input type="text"/> Channel Flow = <input type="text"/> <input type="text"/>	
Rainfall Information: Intensity I (inch/hr) = $C_1 * P_1 / (C_2 + I_c)^{C_3}$		Minor Storm Major Storm	
		Design Storm Return Period, T _r = <input type="text"/> years	
		Return Period One-Hour Precipitation, P ₁ = <input type="text"/> inches	
		C ₁ = <input type="text"/>	
		C ₂ = <input type="text"/>	
		C ₃ = <input type="text"/>	
User-Defined Storm Runoff Coefficient (leave this blank to accept a calculated value), C = <input type="text"/>		User-Defined 5-yr. Runoff Coefficient (leave this blank to accept a calculated value), C ₅ = <input type="text"/>	
		Bypass (Carry-Over) Flow from upstream Subcatchments, Q _b = <input type="text" value="0.0"/> <input type="text" value="0.0"/> cfs	
		Total Design Peak Flow, Q = <input type="text" value="2.5"/> <input type="text" value="7.0"/> cfs	

ALLOWABLE CAPACITY FOR ONE-HALF OF STREET (Minor & Major Storm)

(Based on Regulated Criteria for Maximum Allowable Flow Depth and Spread)

Project: **COMPARK SOUTH**
 Inlet ID: **INLET 2-11A**

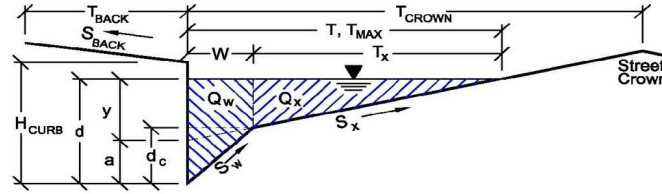

Gutter Geometry (Enter data in the blue cells)																	
Maximum Allowable Width for Spread Behind Curb	$T_{BACK} = $ <input style="width: 50px;" type="text" value="0.0"/> ft																
Side Slope Behind Curb (leave blank for no conveyance credit behind curb)	$S_{BACK} = $ <input style="width: 50px;" type="text" value="0.020"/> ft/ft																
Manning's Roughness Behind Curb (typically between 0.012 and 0.020)	$n_{BACK} = $ <input style="width: 50px;" type="text" value="0.020"/>																
Height of Curb at Gutter Flow Line	$H_{CURB} = $ <input style="width: 50px;" type="text" value="4.00"/> inches																
Distance from Curb Face to Street Crown	$T_{CROWN} = $ <input style="width: 50px;" type="text" value="17.0"/> ft																
Gutter Width	$W = $ <input style="width: 50px;" type="text" value="2.00"/> ft																
Street Transverse Slope	$S_x = $ <input style="width: 50px;" type="text" value="0.021"/> ft/ft																
Gutter Cross Slope (typically 2 inches over 24 inches or 0.083 ft/ft)	$S_w = $ <input style="width: 50px;" type="text" value="0.083"/> ft/ft																
Street Longitudinal Slope - Enter 0 for sump condition	$S_o = $ <input style="width: 50px;" type="text" value="0.010"/> ft/ft																
Manning's Roughness for Street Section (typically between 0.012 and 0.020)	$n_{STREET} = $ <input style="width: 50px;" type="text" value="0.016"/>																
Max. Allowable Spread for Minor & Major Storm	<table style="width: 100%; border-collapse: collapse;"> <thead> <tr> <th style="width: 50%;"></th> <th style="width: 25%; text-align: center;">Minor Storm</th> <th style="width: 25%; text-align: center;">Major Storm</th> <th style="width: 10%;"></th> </tr> </thead> <tbody> <tr> <td>$T_{MAX} =$</td> <td style="text-align: center;"><input style="width: 50px;" type="text" value="17.0"/></td> <td style="text-align: center;"><input style="width: 50px;" type="text" value="17.0"/></td> <td style="text-align: right;">ft</td> </tr> <tr> <td>$d_{MAX} =$</td> <td style="text-align: center;"><input style="width: 50px;" type="text" value="4.0"/></td> <td style="text-align: center;"><input style="width: 50px;" type="text" value="12.0"/></td> <td style="text-align: right;">inches</td> </tr> <tr> <td>Allow Flow Depth at Street Crown (leave blank for no)</td> <td style="text-align: center;"><input type="checkbox"/></td> <td style="text-align: center;"><input type="checkbox"/></td> <td style="text-align: right;">check = yes</td> </tr> </tbody> </table>		Minor Storm	Major Storm		$T_{MAX} = $	<input style="width: 50px;" type="text" value="17.0"/>	<input style="width: 50px;" type="text" value="17.0"/>	ft	$d_{MAX} = $	<input style="width: 50px;" type="text" value="4.0"/>	<input style="width: 50px;" type="text" value="12.0"/>	inches	Allow Flow Depth at Street Crown (leave blank for no)	<input type="checkbox"/>	<input type="checkbox"/>	check = yes
	Minor Storm	Major Storm															
$T_{MAX} = $	<input style="width: 50px;" type="text" value="17.0"/>	<input style="width: 50px;" type="text" value="17.0"/>	ft														
$d_{MAX} = $	<input style="width: 50px;" type="text" value="4.0"/>	<input style="width: 50px;" type="text" value="12.0"/>	inches														
Allow Flow Depth at Street Crown (leave blank for no)	<input type="checkbox"/>	<input type="checkbox"/>	check = yes														
MINOR STORM Allowable Capacity is based on Depth Criterion																	
MAJOR STORM Allowable Capacity is based on Spread Criterion																	
Minor storm max. allowable capacity GOOD - greater than flow given on sheet 'Q-Peak'																	
Major storm max. allowable capacity GOOD - greater than flow given on sheet 'Q-Peak'																	
$Q_{allow} = $	<table style="width: 100%; border-collapse: collapse;"> <thead> <tr> <th style="width: 50%;"></th> <th style="width: 25%; text-align: center;">Minor Storm</th> <th style="width: 25%; text-align: center;">Major Storm</th> <th style="width: 10%;"></th> </tr> </thead> <tbody> <tr> <td></td> <td style="text-align: center;"><input style="width: 50px;" type="text" value="3.3"/></td> <td style="text-align: center;"><input style="width: 50px;" type="text" value="11.6"/></td> <td style="text-align: right;">cfs</td> </tr> </tbody> </table>		Minor Storm	Major Storm			<input style="width: 50px;" type="text" value="3.3"/>	<input style="width: 50px;" type="text" value="11.6"/>	cfs								
	Minor Storm	Major Storm															
	<input style="width: 50px;" type="text" value="3.3"/>	<input style="width: 50px;" type="text" value="11.6"/>	cfs														

INLET ON A CONTINUOUS GRADE

Project: COMPARK SOUTH
 Inlet ID: INLET 2-11A

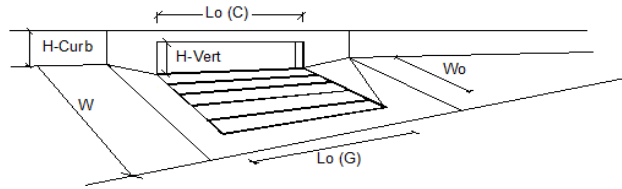

Design Information (Input)	MINOR		MAJOR	
	Type of Inlet	Type = CDOT Type R Curb Opening		
Local Depression (additional to continuous gutter depression 'a' from 'Q-Allow')	$a_{LOCAL} = 5.0$	5.0	inches	
Total Number of Units in the Inlet (Grate or Curb Opening)	$N_o = 2$	2		
Length of a Single Unit Inlet (Grate or Curb Opening)	$L_o = 5.00$	5.00	ft	
Width of a Unit Grate (cannot be greater than W from Q-Allow)	$W_o = N/A$	N/A	ft	
Clogging Factor for a Single Unit Grate (typical min. value = 0.5)	$C_r-G = N/A$	N/A		
Clogging Factor for a Single Unit Curb Opening (typical min. value = 0.1)	$C_r-C = 0.10$	0.10		
Street Hydraulics: OK - Q < maximum allowable from sheet 'Q-Allow'				
Total Inlet Interception Capacity	$Q = 2.50$	6.36	cfs	
Total Inlet Carry-Over Flow (flow bypassing inlet)	$Q_b = 0.0$	0.6	cfs	
Capture Percentage = $Q_a/Q_o =$	$C\% = 100$	91	%	

Profile Report

Engineering Profile - Profile - Storm Line 4 (Compark Village South StormCAD [2 year].stsw)

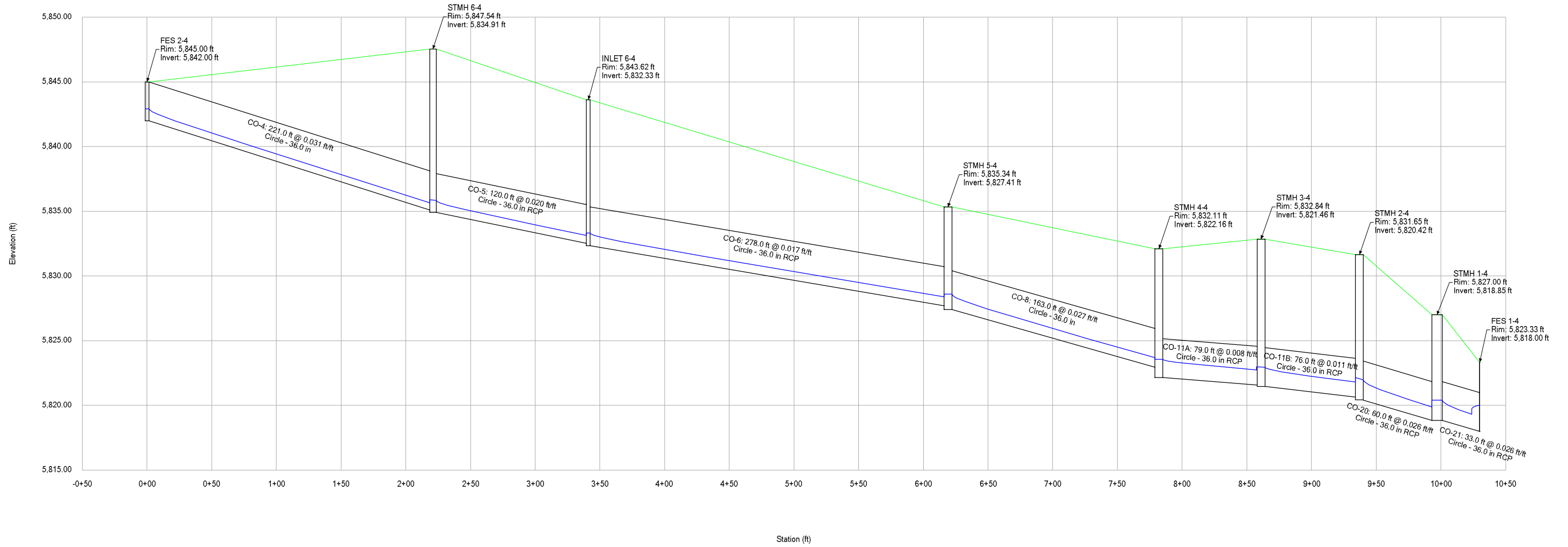

Profile Report

Engineering Profile - Profile - Storm Line 4 (Compark Village South StormCAD [5 year].stsw)

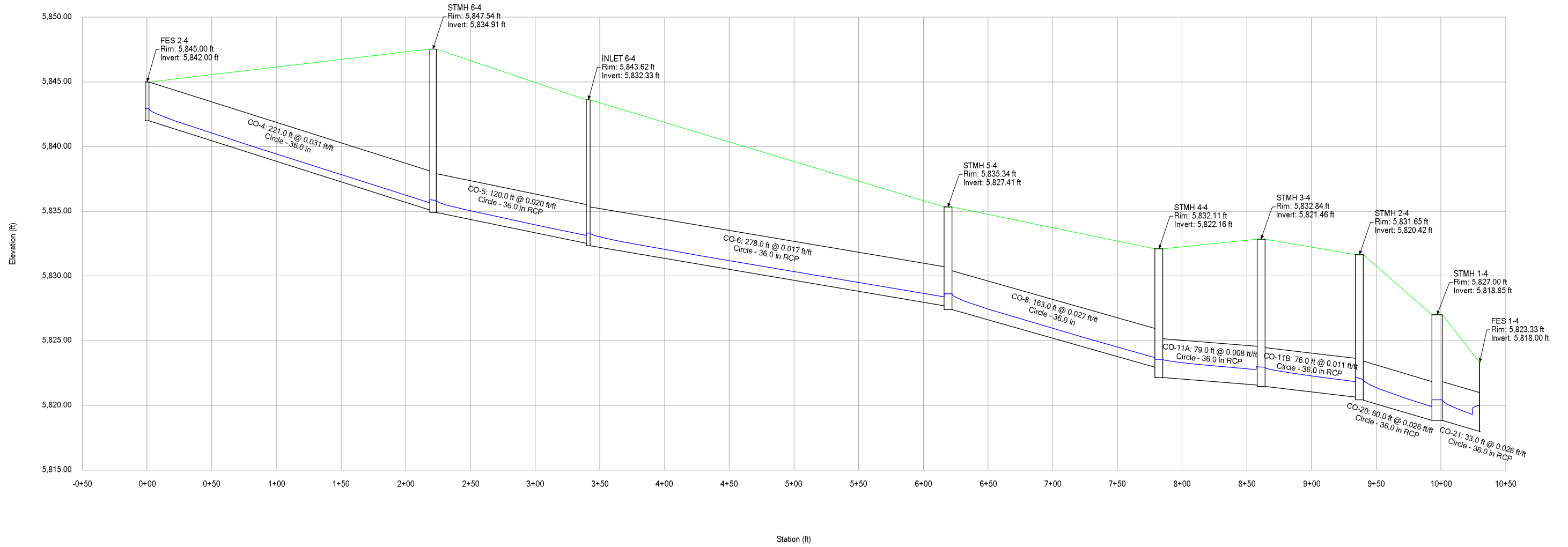

Profile Report

Engineering Profile - Profile - Storm Line 4 (Compark Village South StormCAD [100 year].stsw)

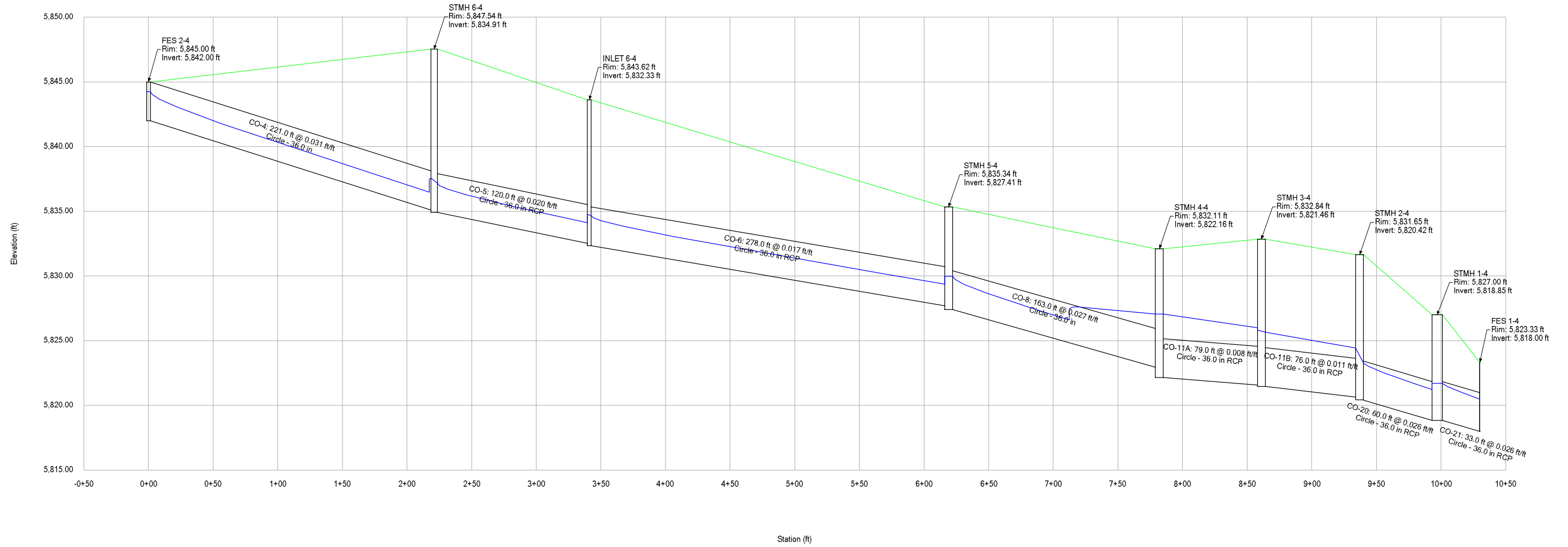

Profile Report
Engineering Profile - Profile - Storm Line 4A (Compark Village South StormCAD [2 year].stsw)

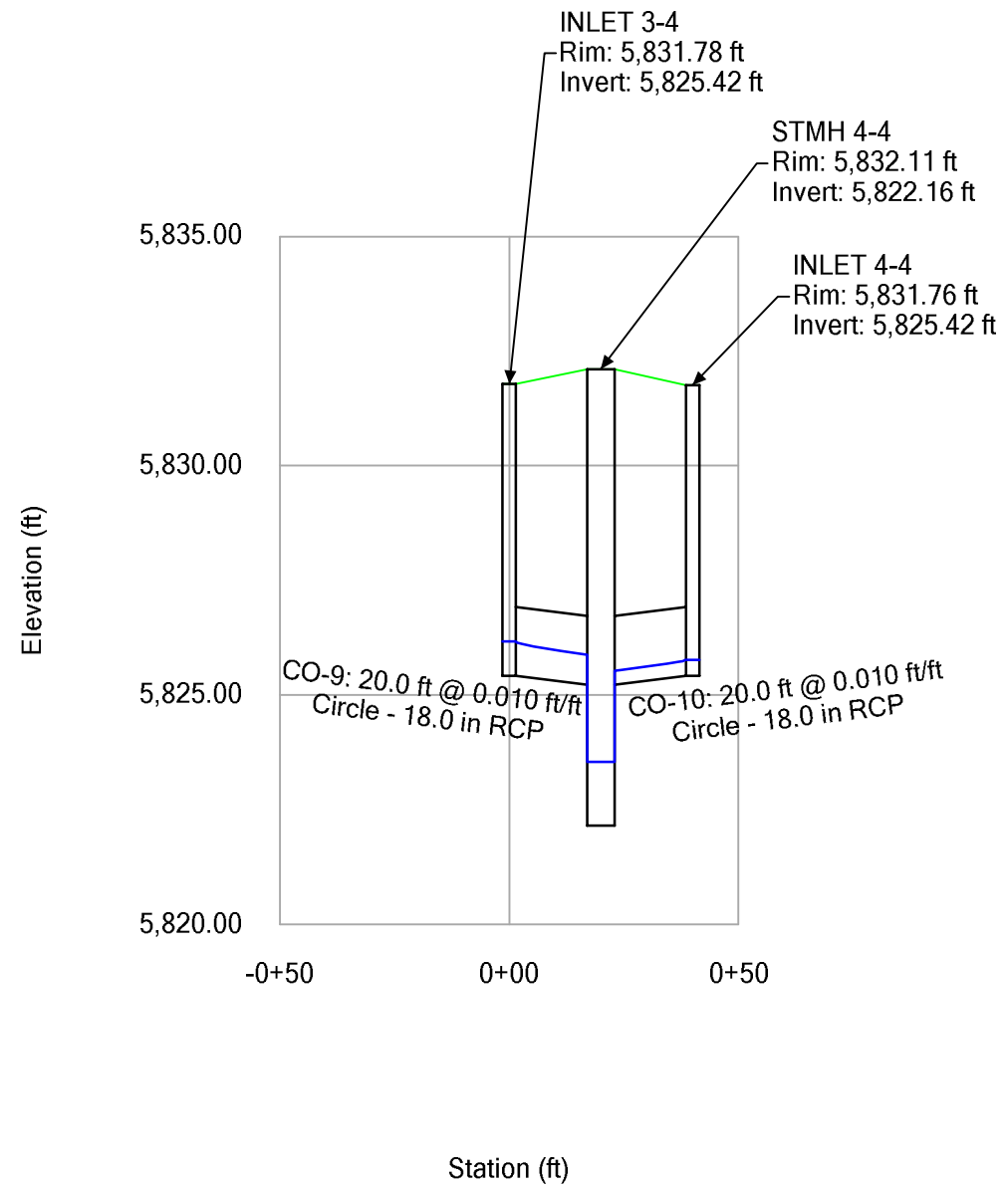

Profile Report
Engineering Profile - Profile - Storm Line 4A (Compark Village South StormCAD [5 year].stsw)

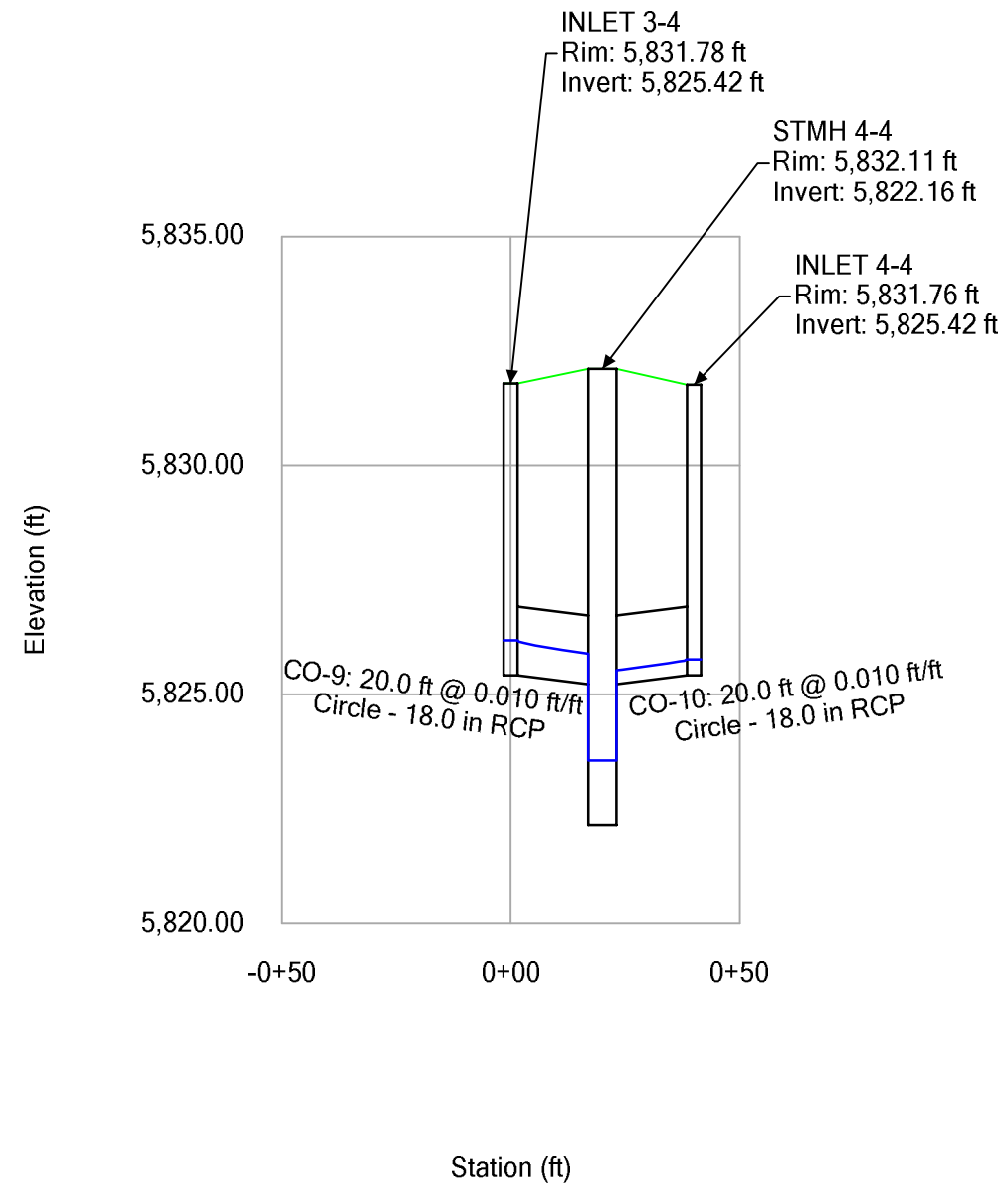

Profile Report
Engineering Profile - Profile - Storm Line 4A (Compark Village South StormCAD [100 year].stsw)

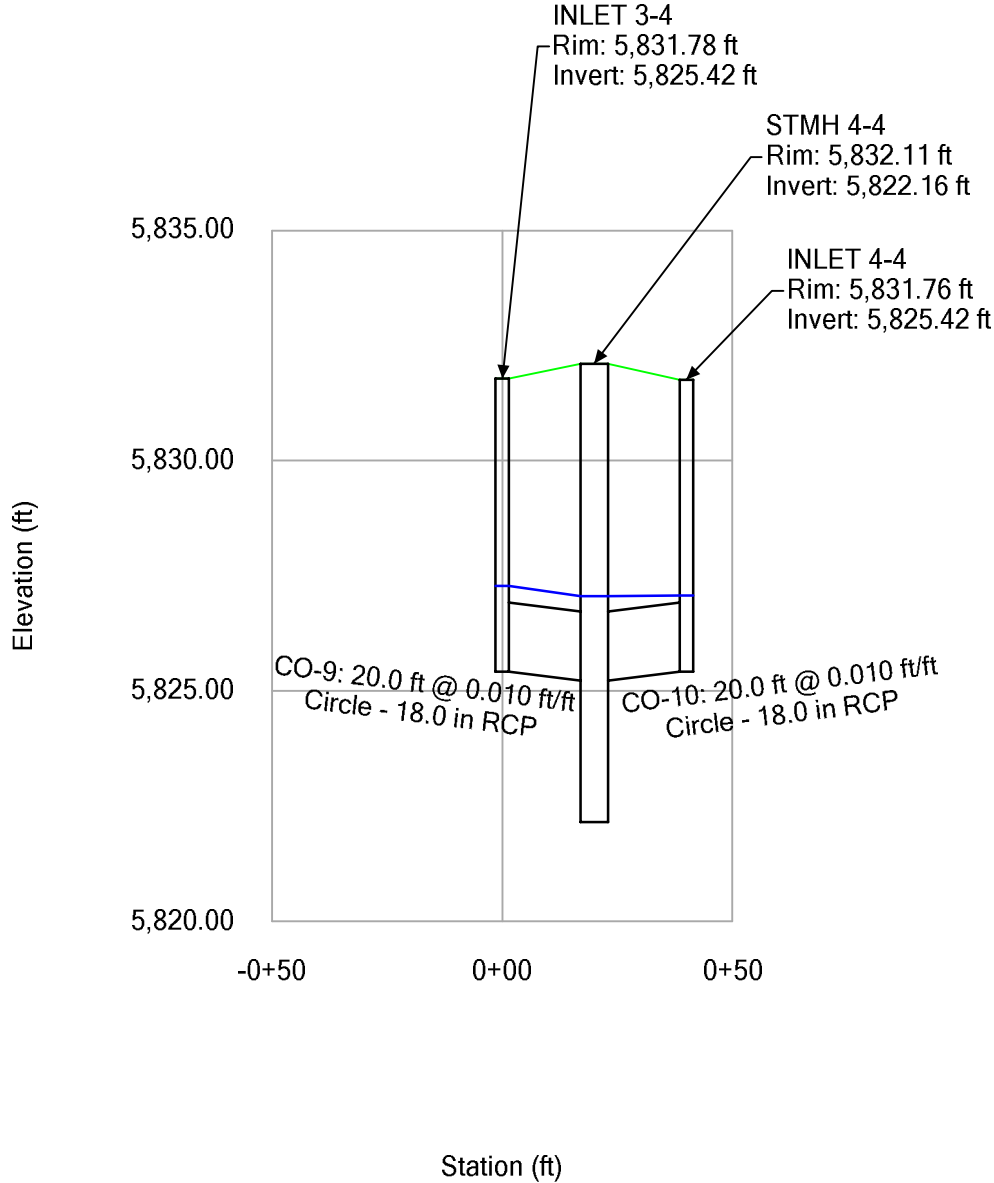

Profile Report
Engineering Profile - Profile - Storm Line 4B (Compark Village South StormCAD [2 year].stsw)

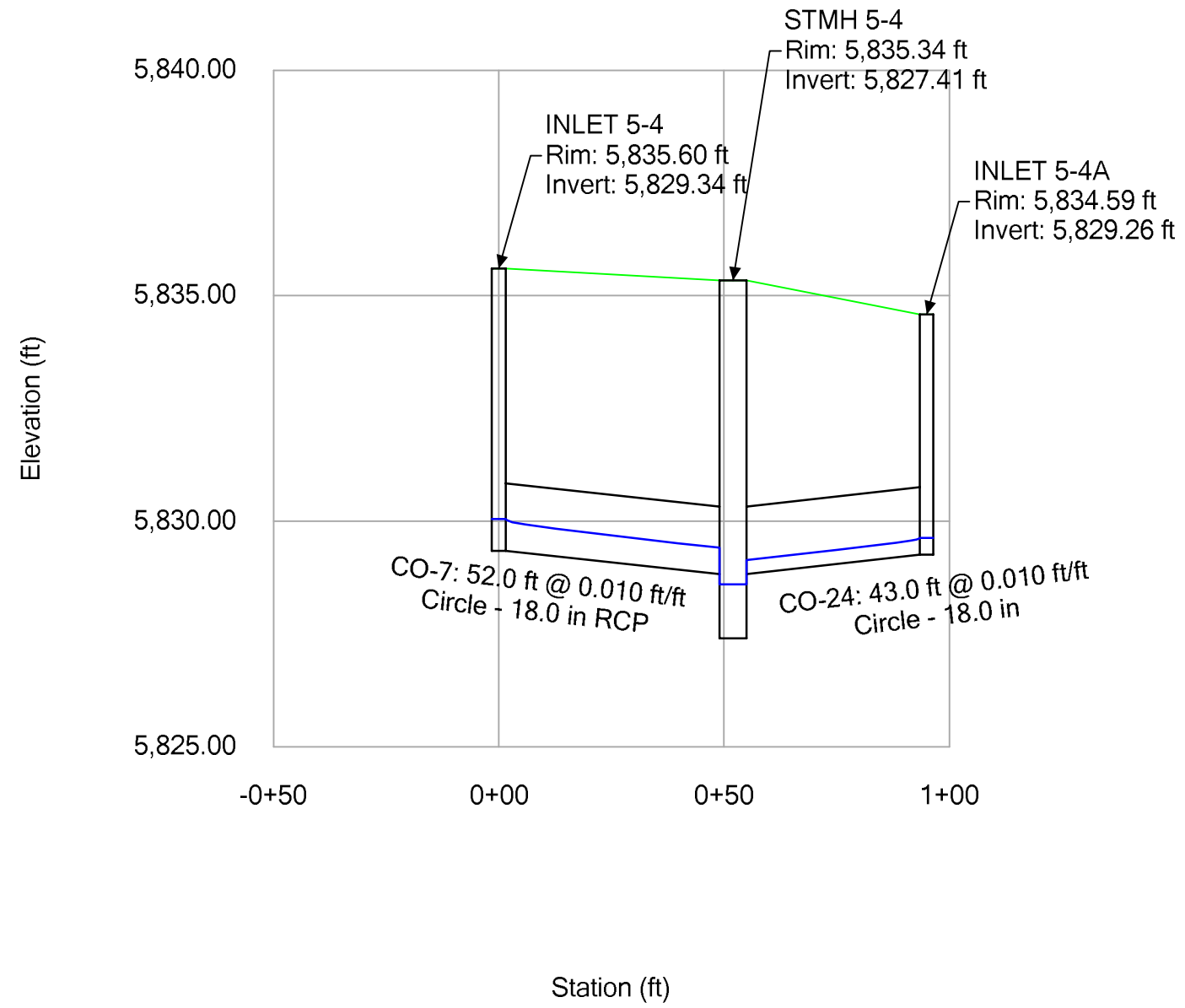

Profile Report
Engineering Profile - Profile - Storm Line 4B (Compark Village South StormCAD [5 year].stsw)

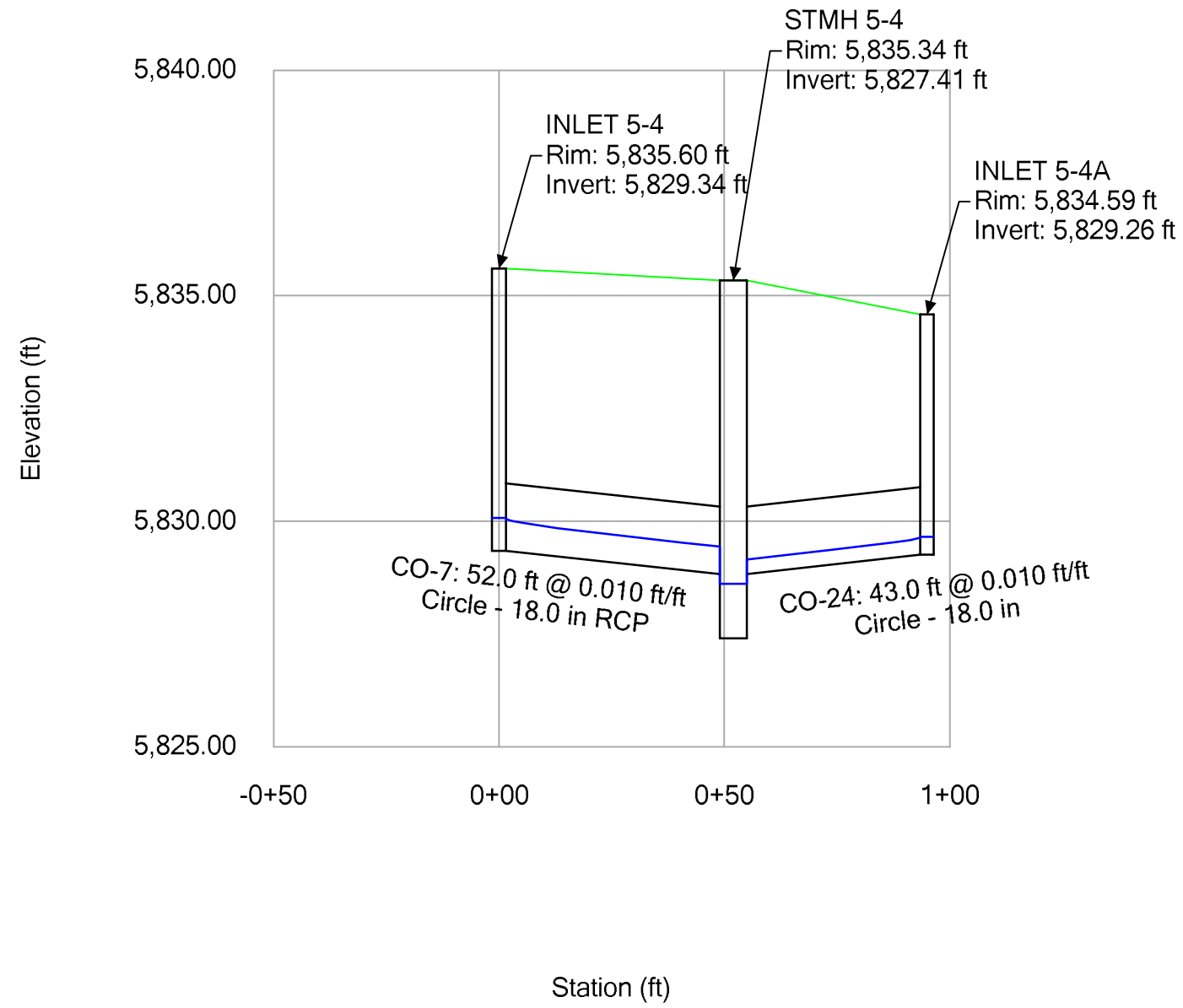

Profile Report
Engineering Profile - Profile - Storm Line 4B (Compark Village South StormCAD [100 year].stsw)

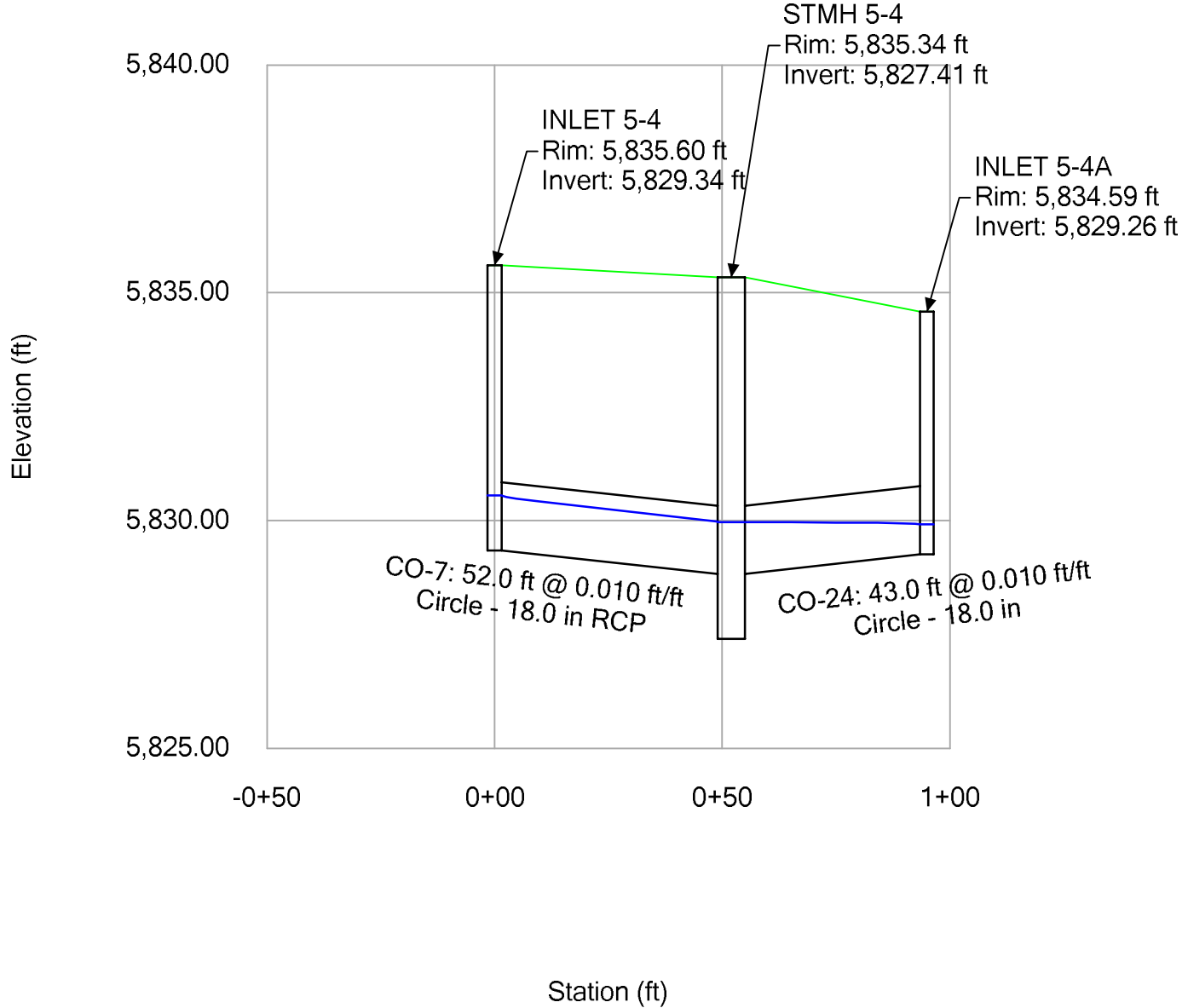

Profile Report

Engineering Profile - Profile - Storm Line 5 (Compark Village South StormCAD [2 year].stsw)

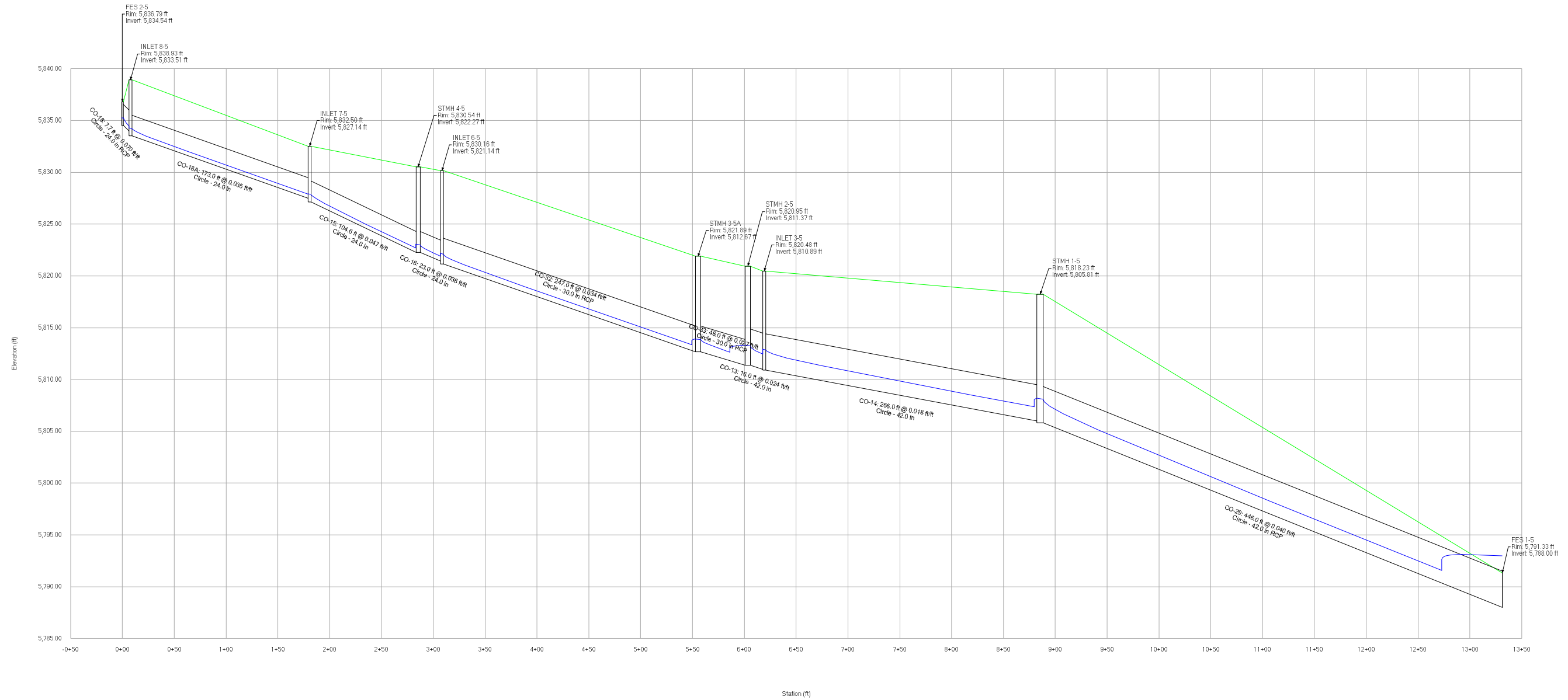

Profile Report

Engineering Profile - Profile - Storm Line 5 (Compark Village South StormCAD [5 year].stsw)

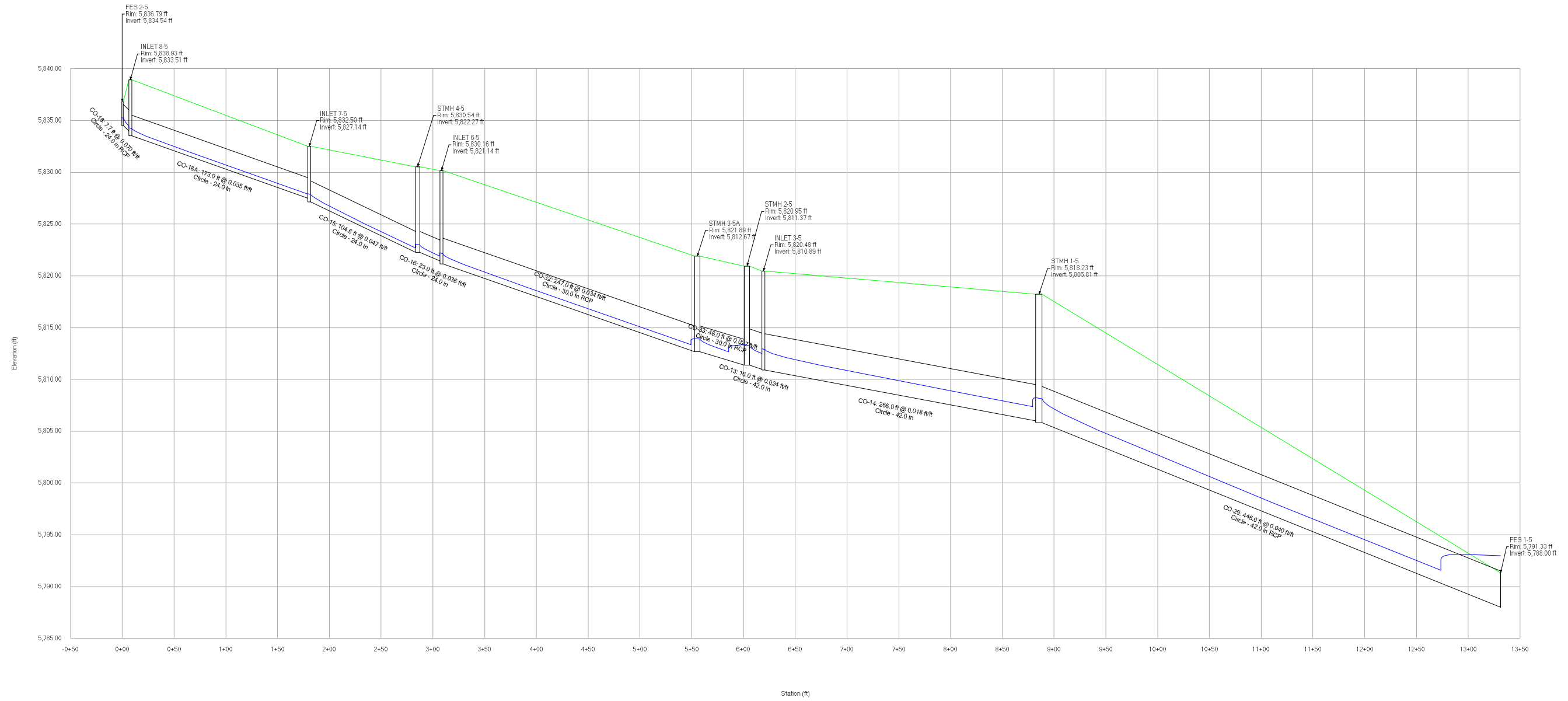

Profile Report

Engineering Profile - Profile - Storm Line 5 (Compark Village South StormCAD [100 year].stsw)

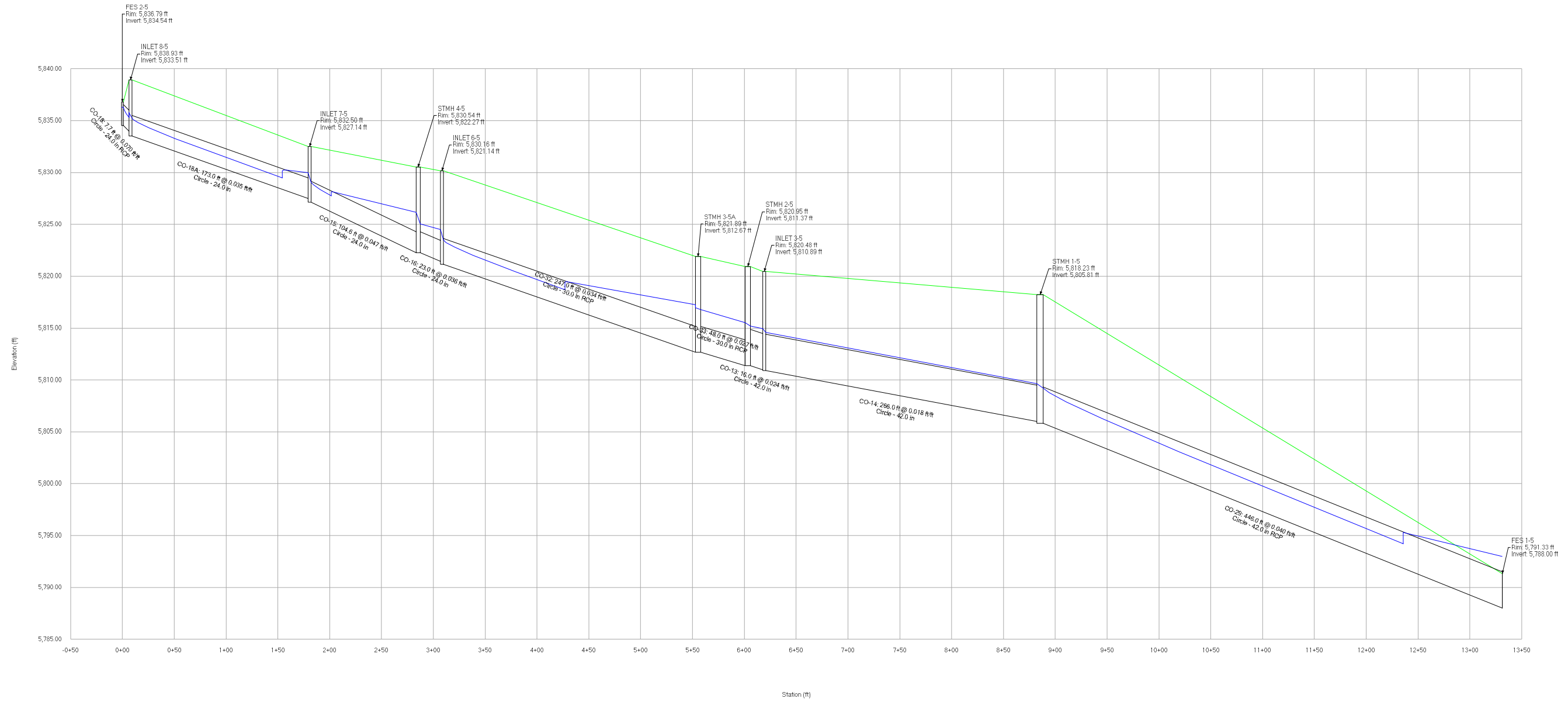

Profile Report
Engineering Profile - Profile - Storm Line 5B (Compark Village South StormCAD [2 year].stsw)

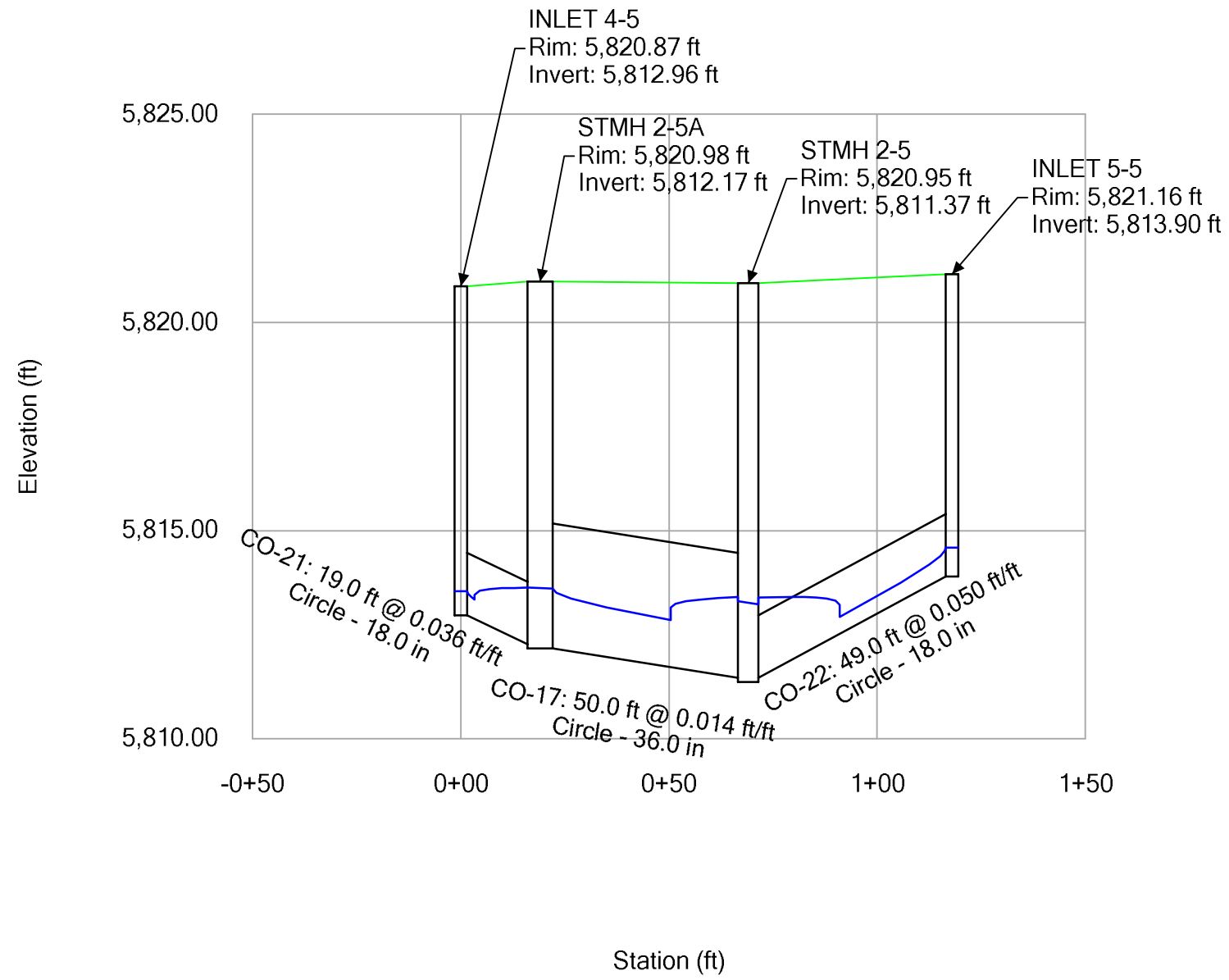

Profile Report
Engineering Profile - Profile - Storm Line 5B (Compark Village South StormCAD [5 year].stsw)

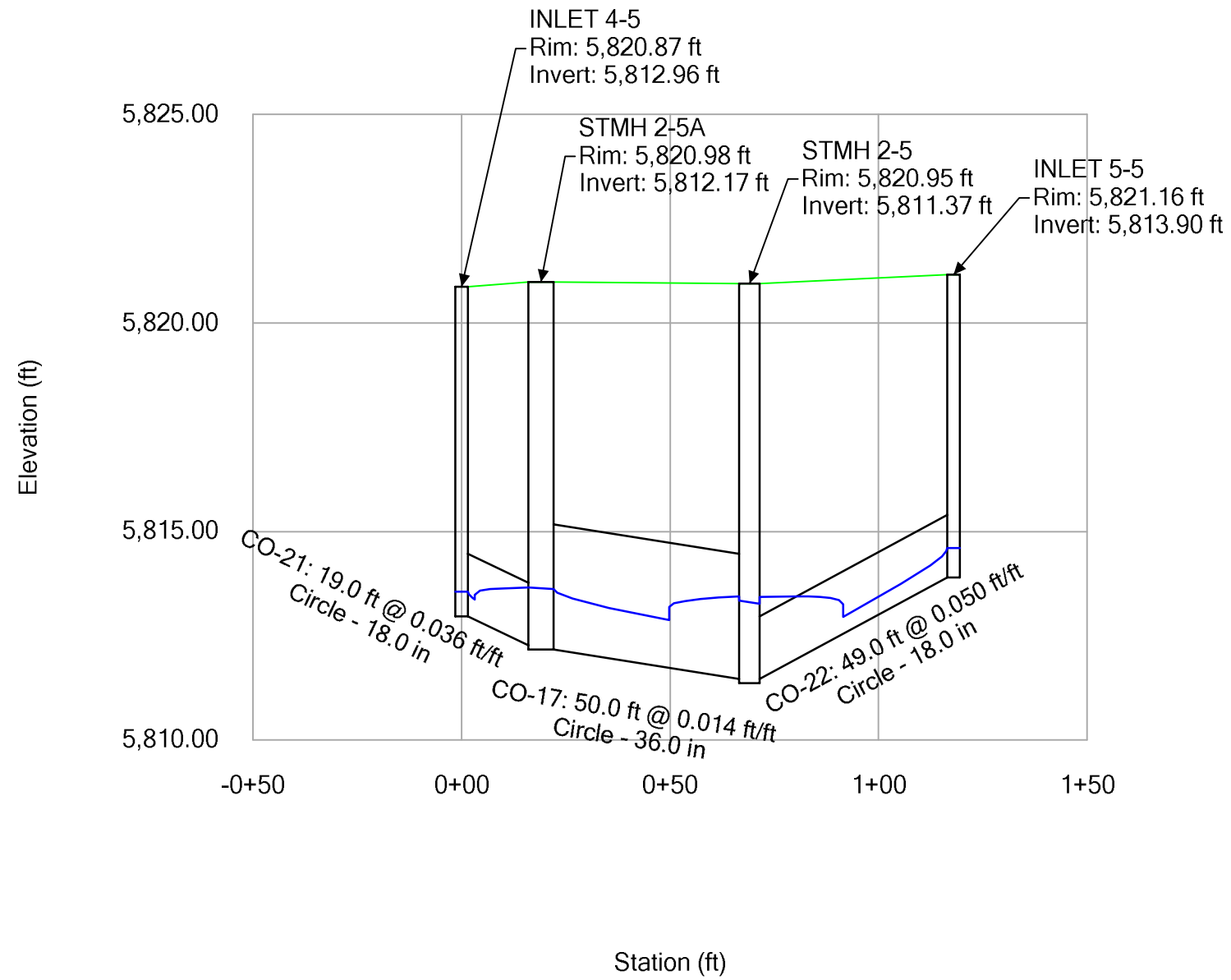

Profile Report
Engineering Profile - Profile - Storm Line 5B (Compark Village South StormCAD [100 year].stsw)

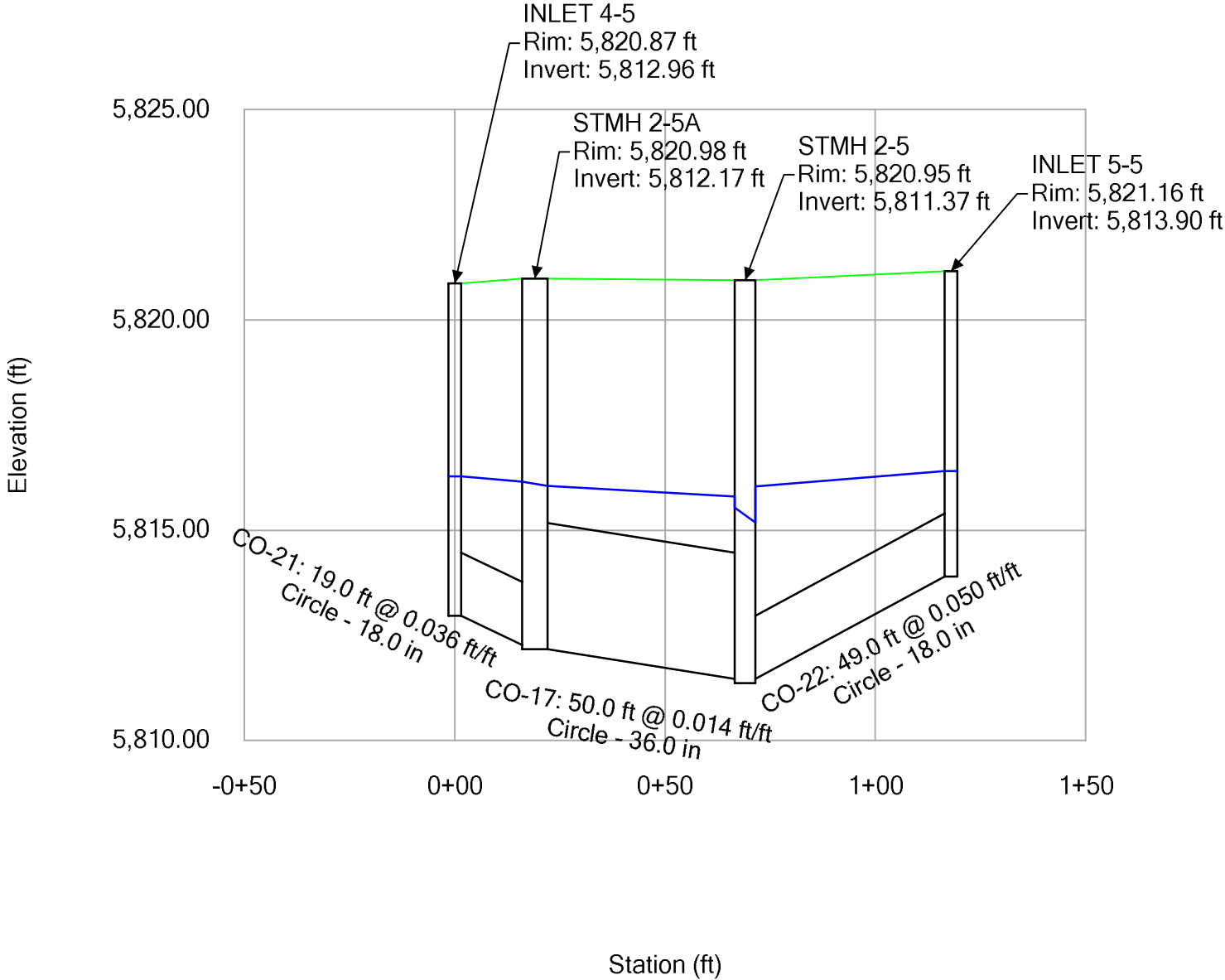

Profile Report

Engineering Profile - Profile - Storm Line 5C (Compark Village South StormCAD [2 year].stsw)

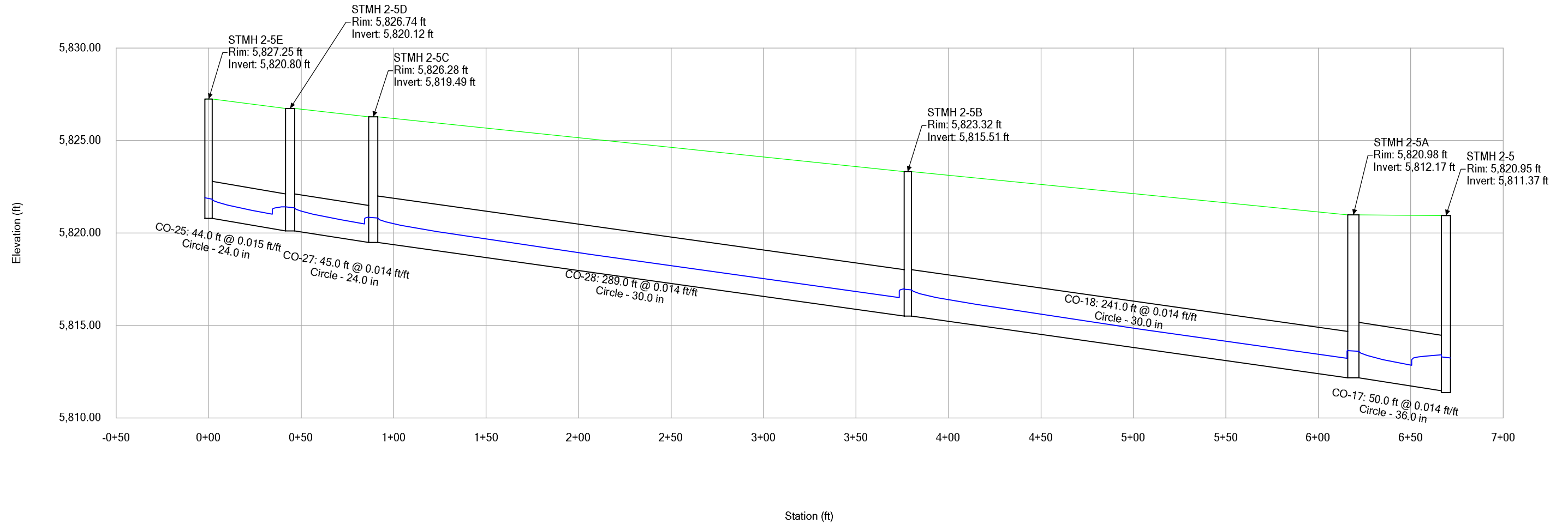

Profile Report

Engineering Profile - Profile - Storm Line 5C (Compark Village South StormCAD [5 year].stsw)

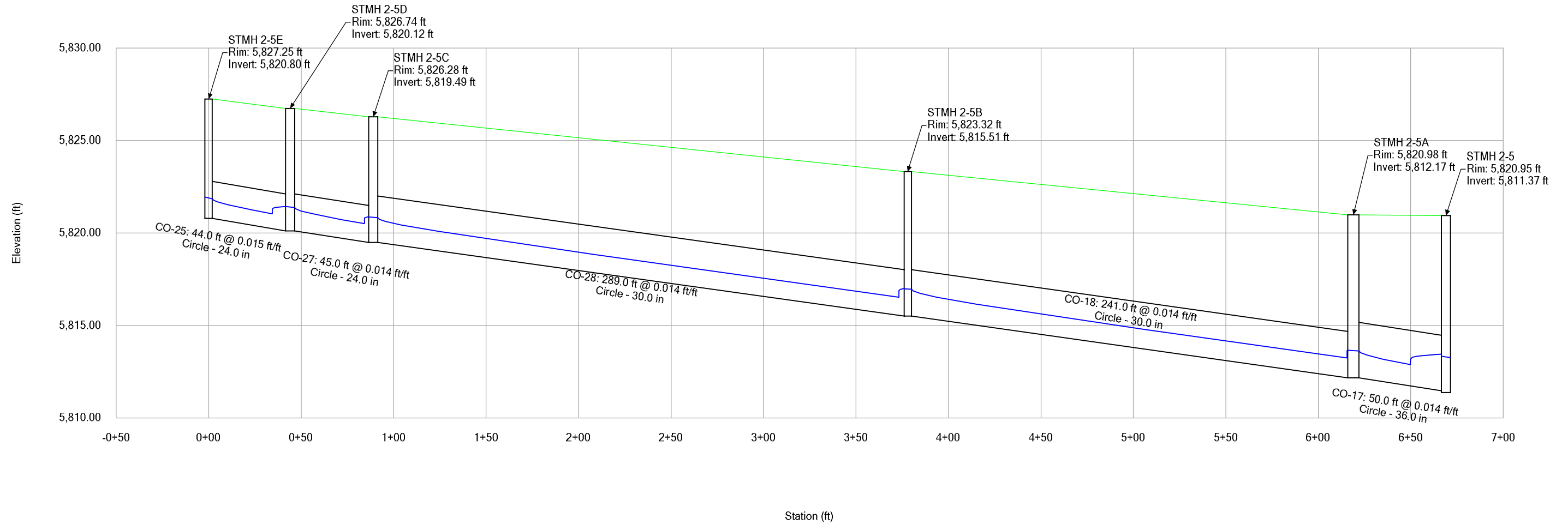

Profile Report

Engineering Profile - Profile - Storm Line 5C (Compark Village South StormCAD [100 year].stsw)

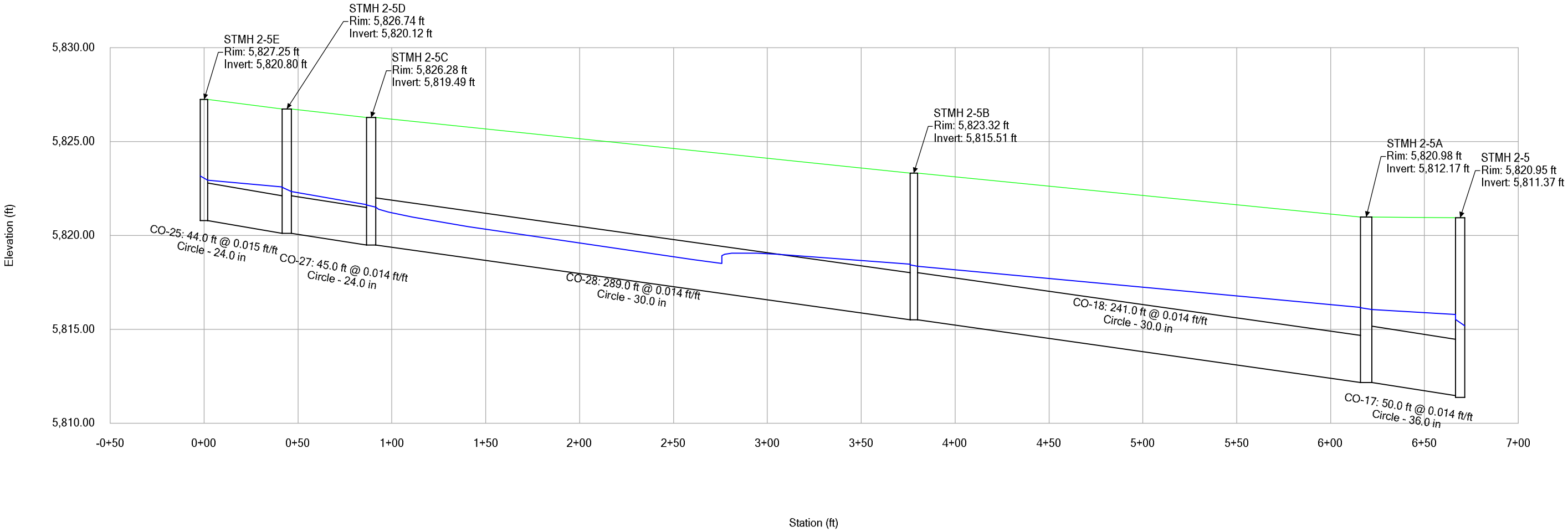

Profile Report
Engineering Profile - Profile - Storm Line 5D (Compark Village South StormCAD [2 year].stsw)

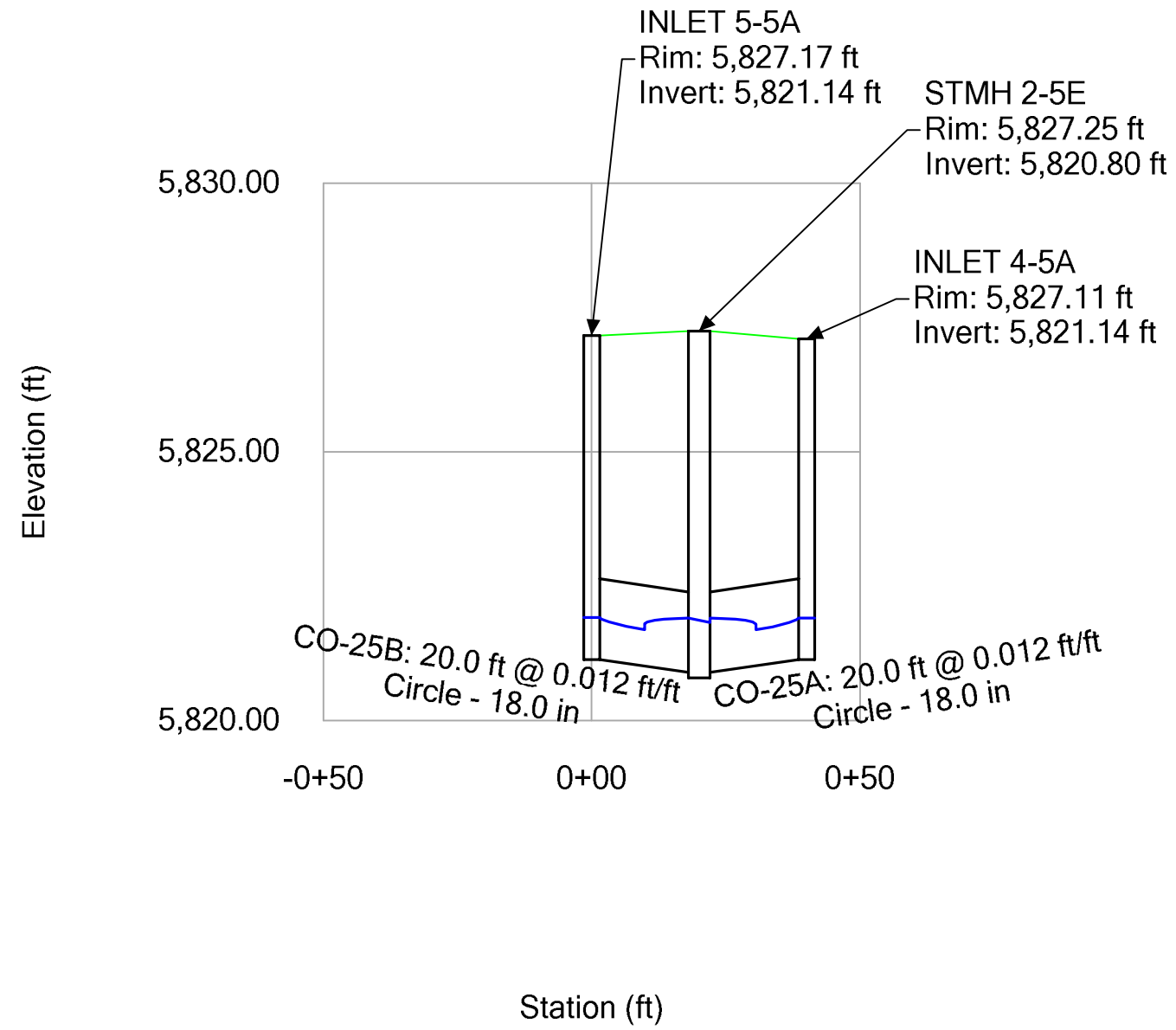

Profile Report
Engineering Profile - Profile - Storm Line 5D (Compark Village South StormCAD [5 year].stsw)

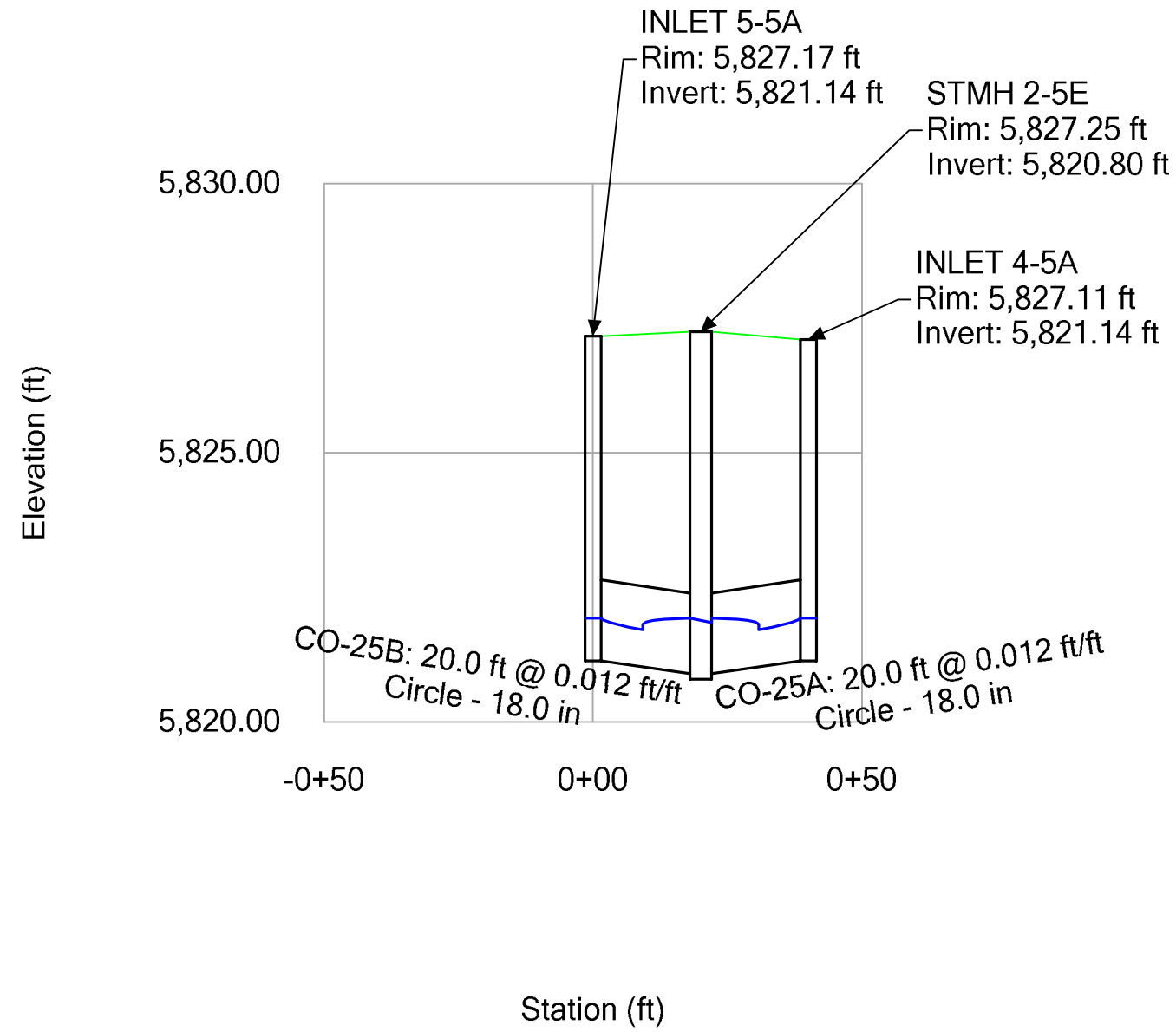

Profile Report
Engineering Profile - Profile - Storm Line 5D (Compark Village South StormCAD [100 year].stsw)

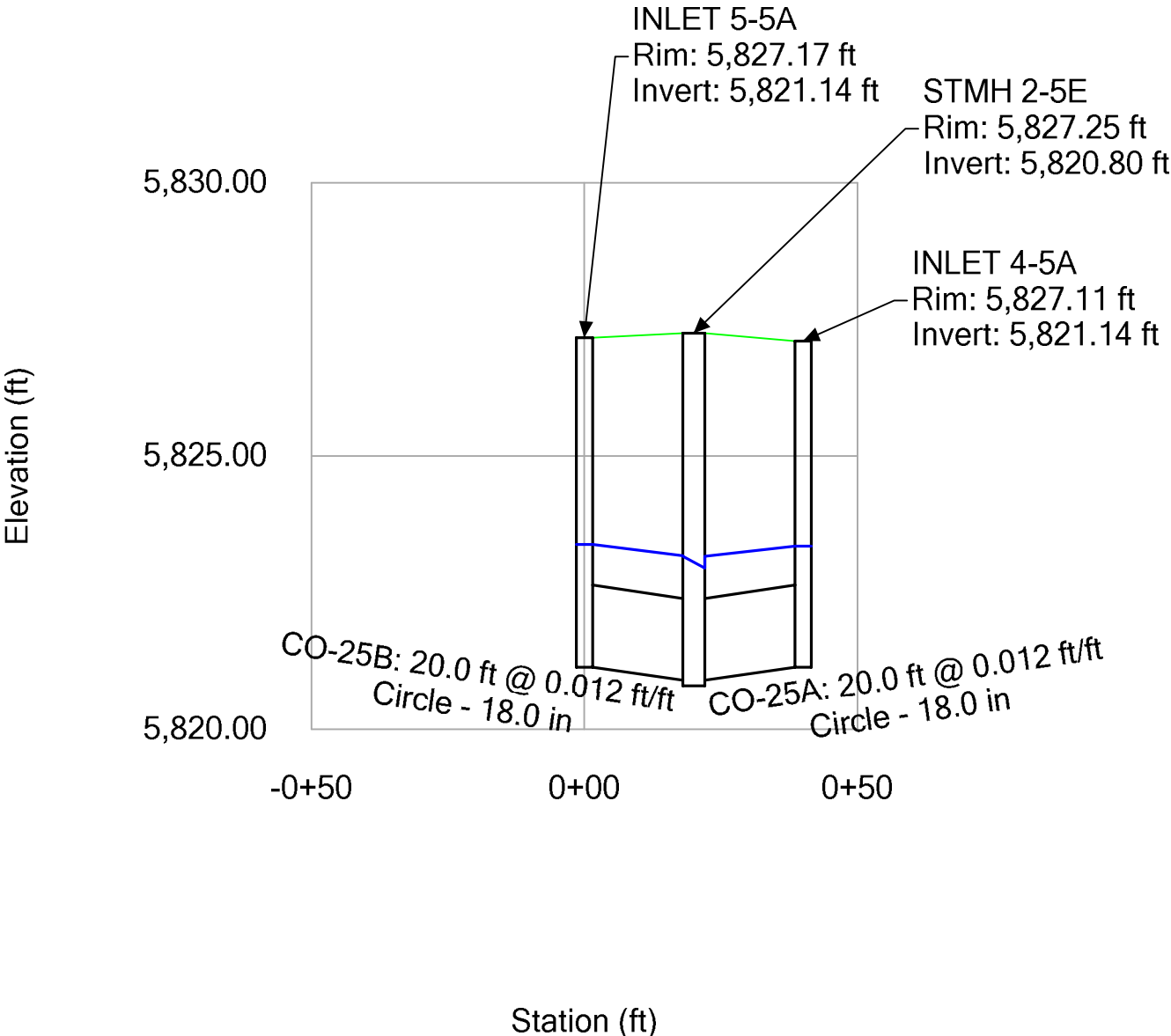

Profile Report
Engineering Profile - Profile - Storm Line 5E (Compark Village South StormCAD [2 year].stsw)

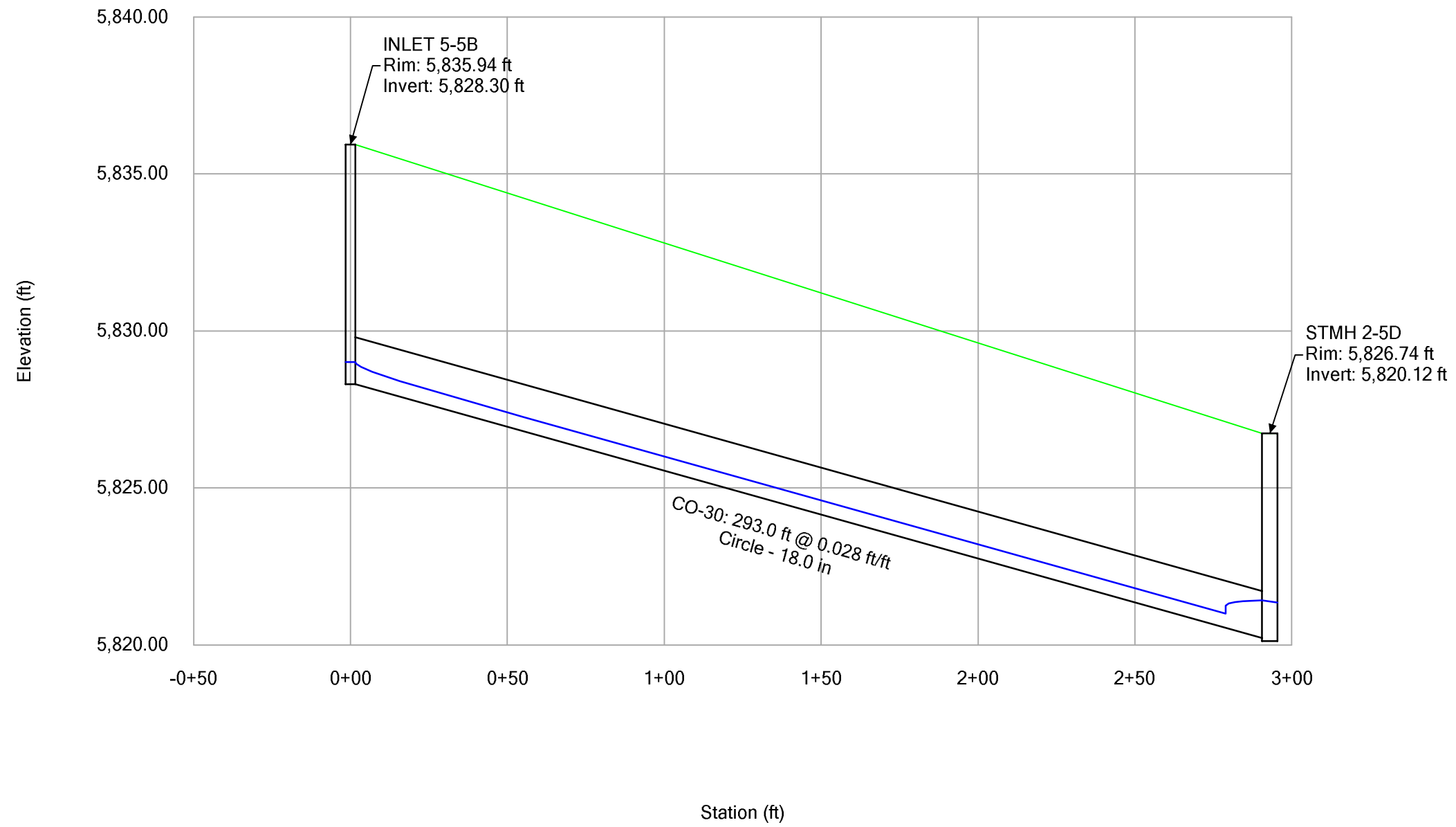

Profile Report
Engineering Profile - Profile - Storm Line 5E (Compark Village South StormCAD [5 year].stsw)

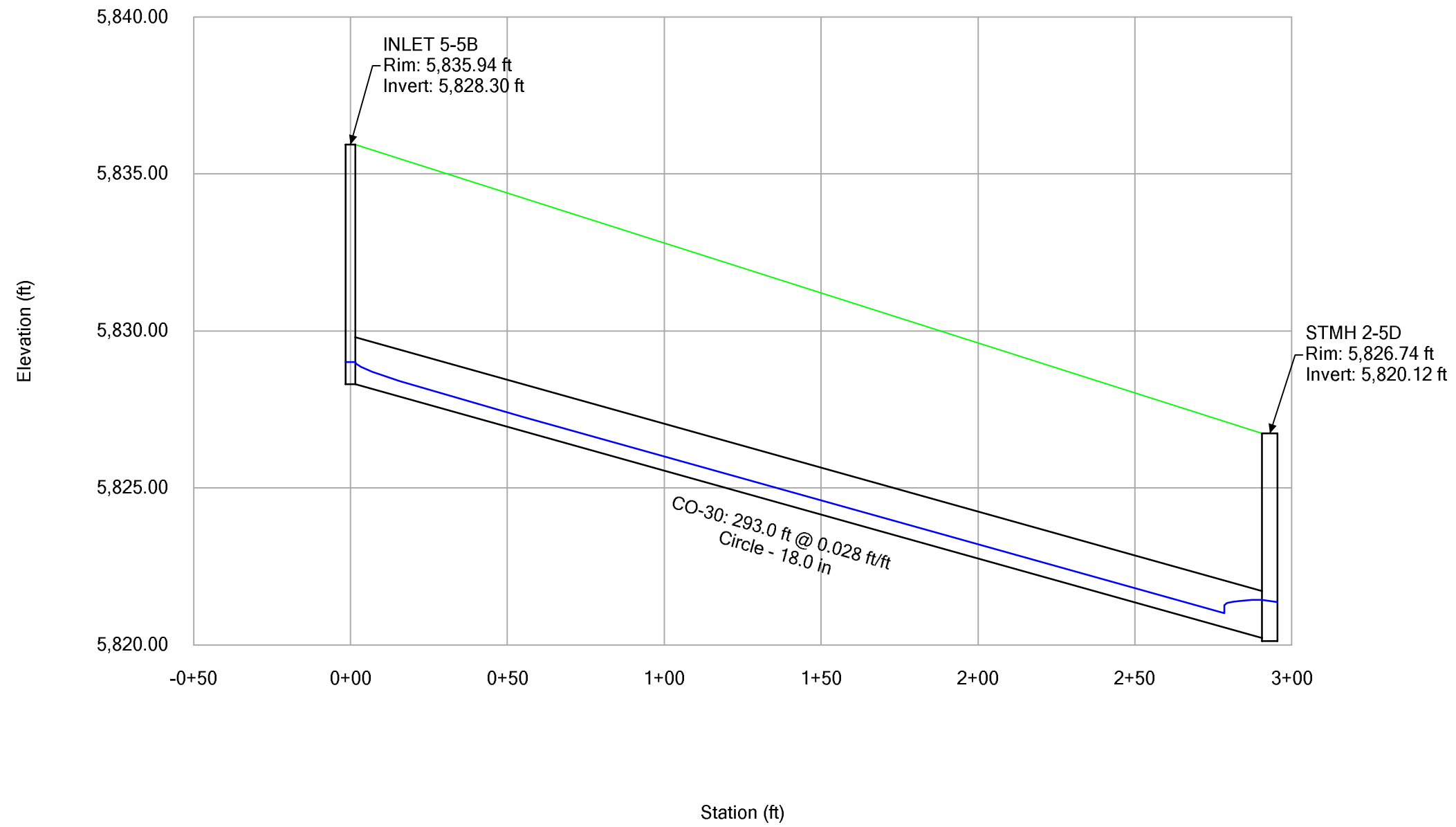

Profile Report
Engineering Profile - Profile - Storm Line 5E (Compark Village South StormCAD [100 year].stsw)

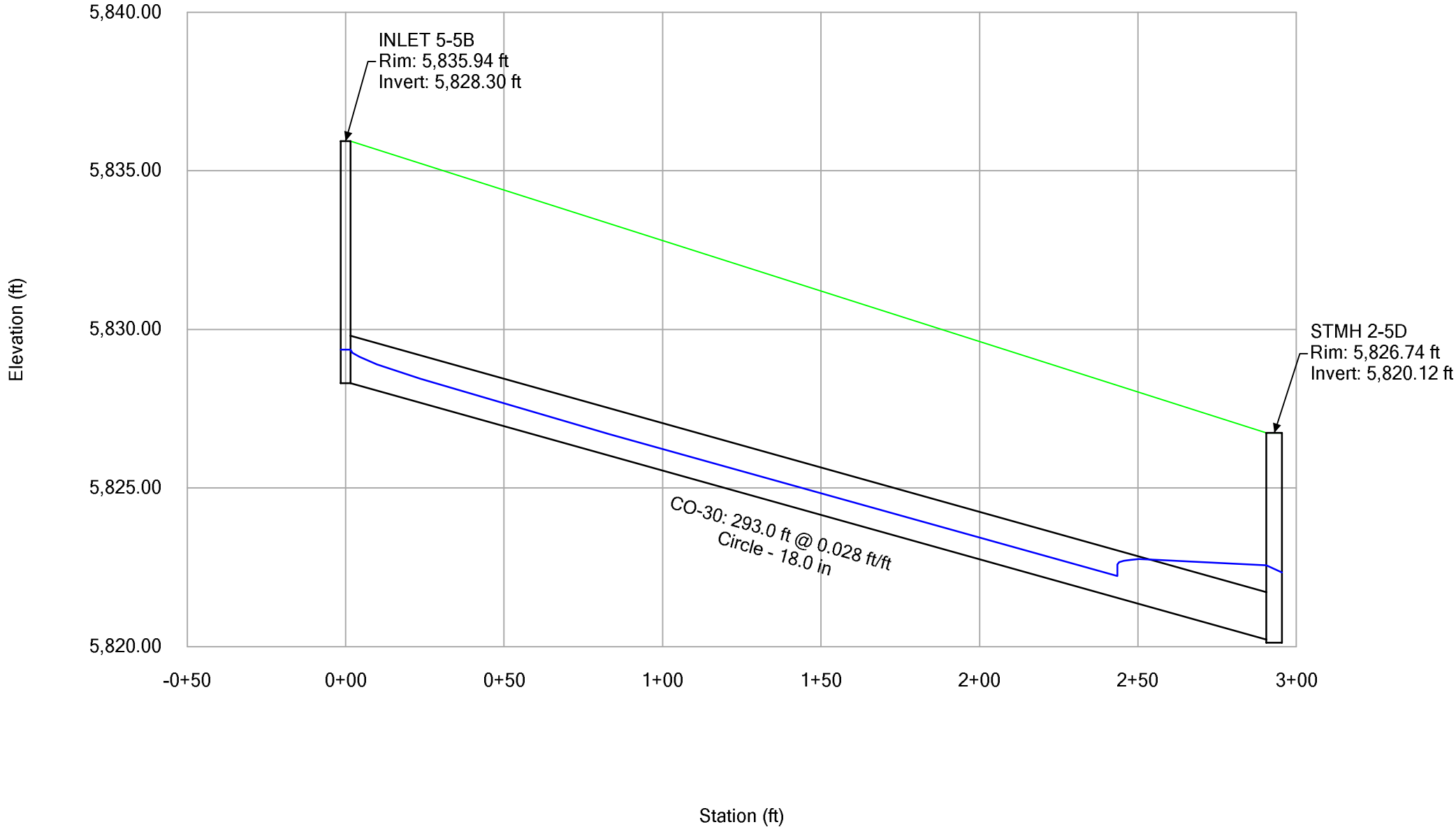

Profile Report
Engineering Profile - Profile - Storm Line 5F (Compark Village South StormCAD [2 year].stsw)

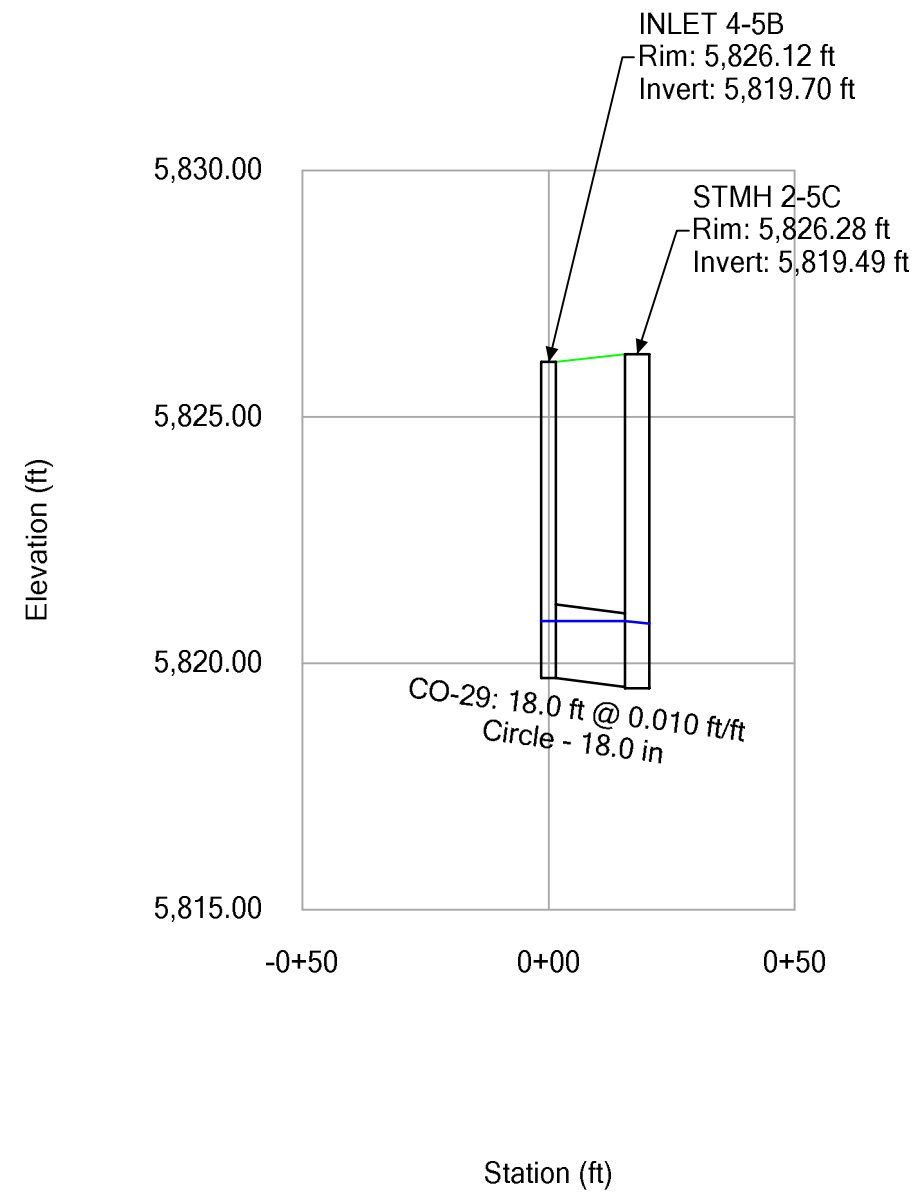

Profile Report
Engineering Profile - Profile - Storm Line 5F (Compark Village South StormCAD [5 year].stsw)

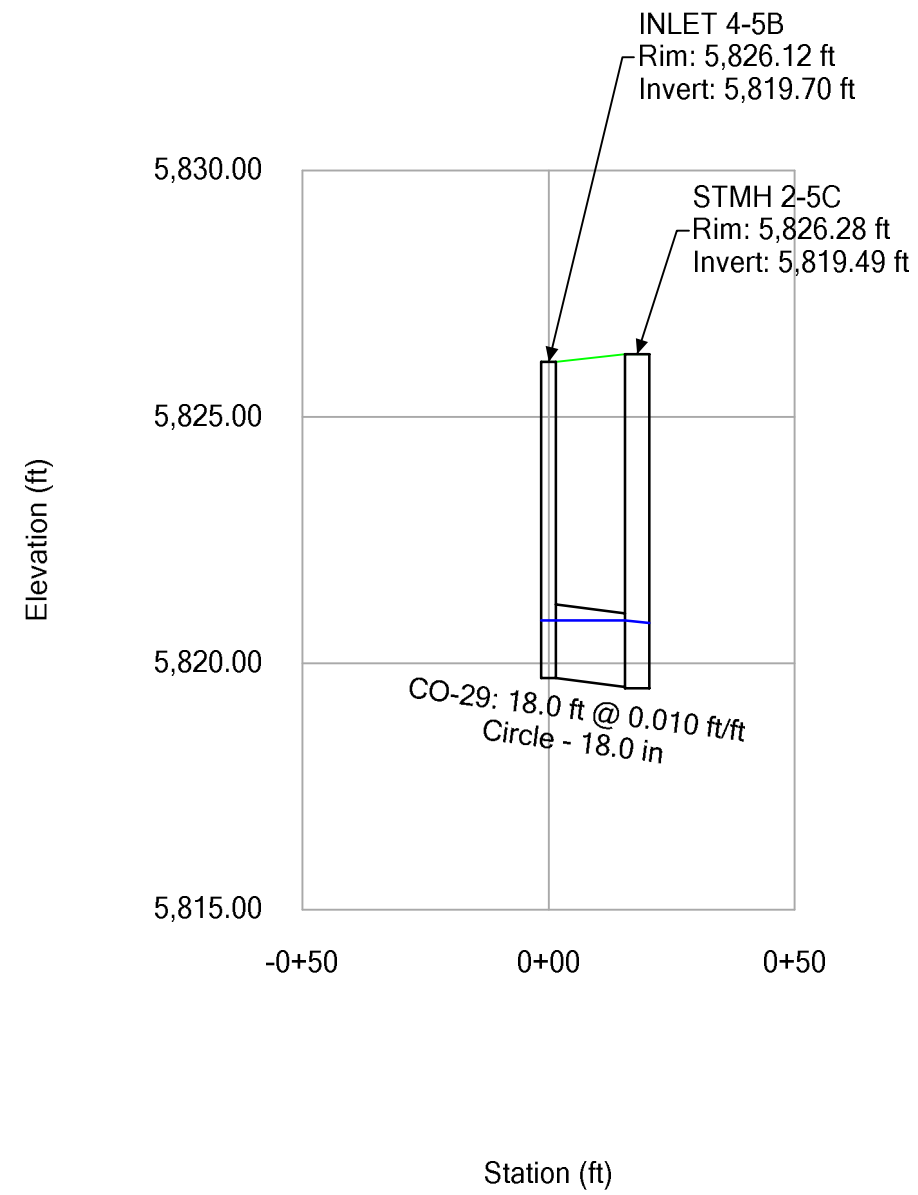

Profile Report
Engineering Profile - Profile - Storm Line 5F (Compark Village South StormCAD [100 year].stsw)

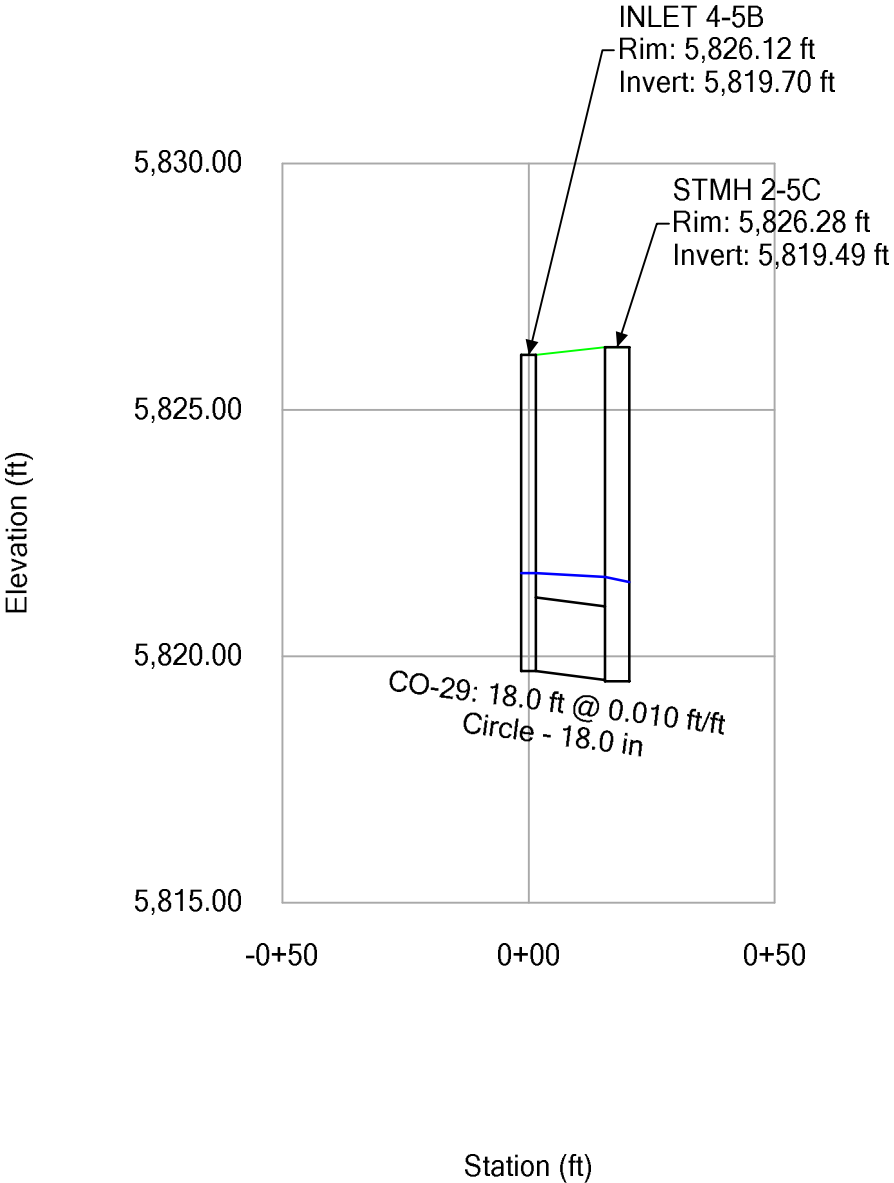

Profile Report
Engineering Profile - Profile - Storm Line 5G (Compark Village South StormCAD [2 year].stsw)

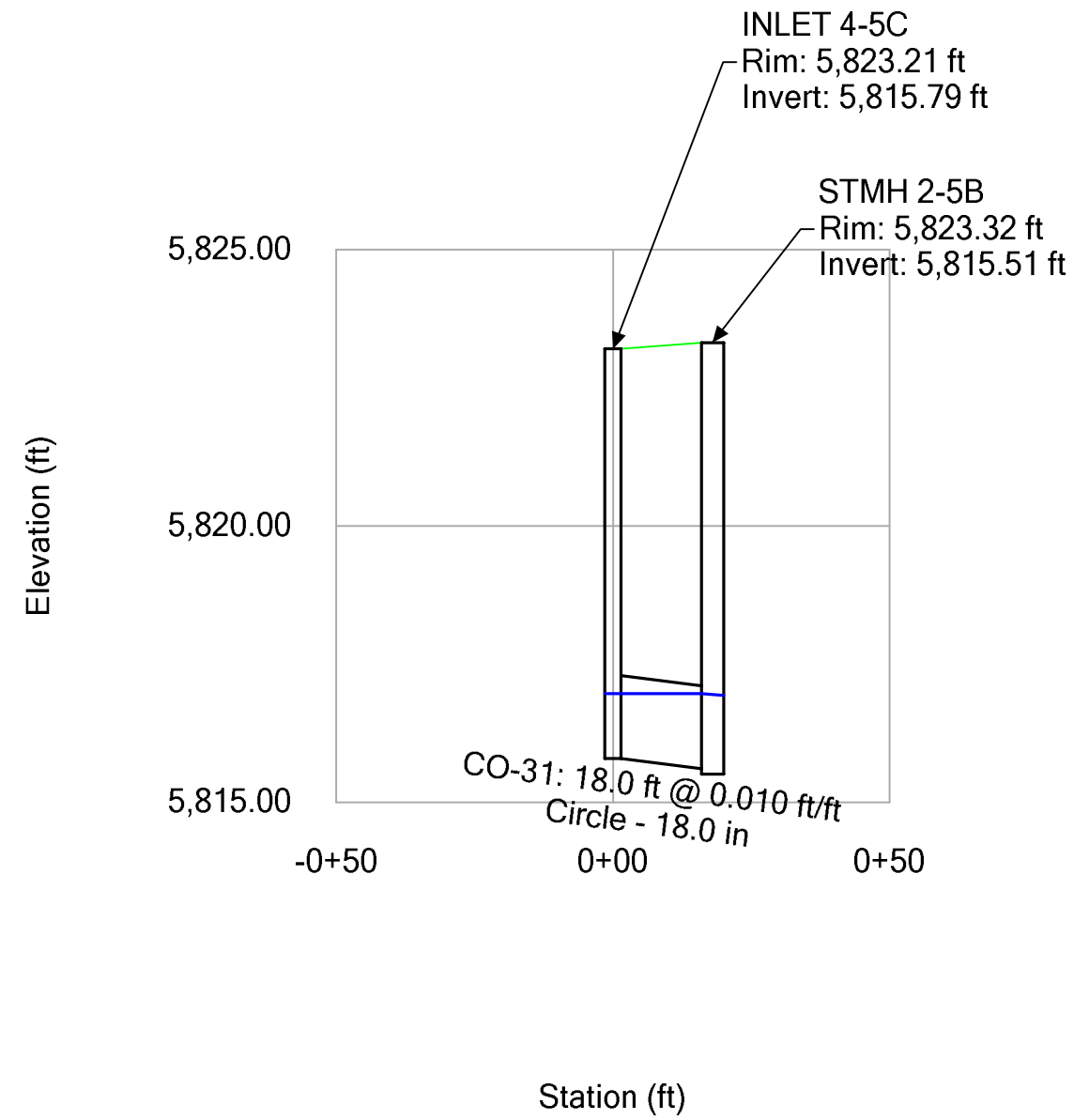

Profile Report
Engineering Profile - Profile - Storm Line 5G (Compark Village South StormCAD [5 year].stsw)

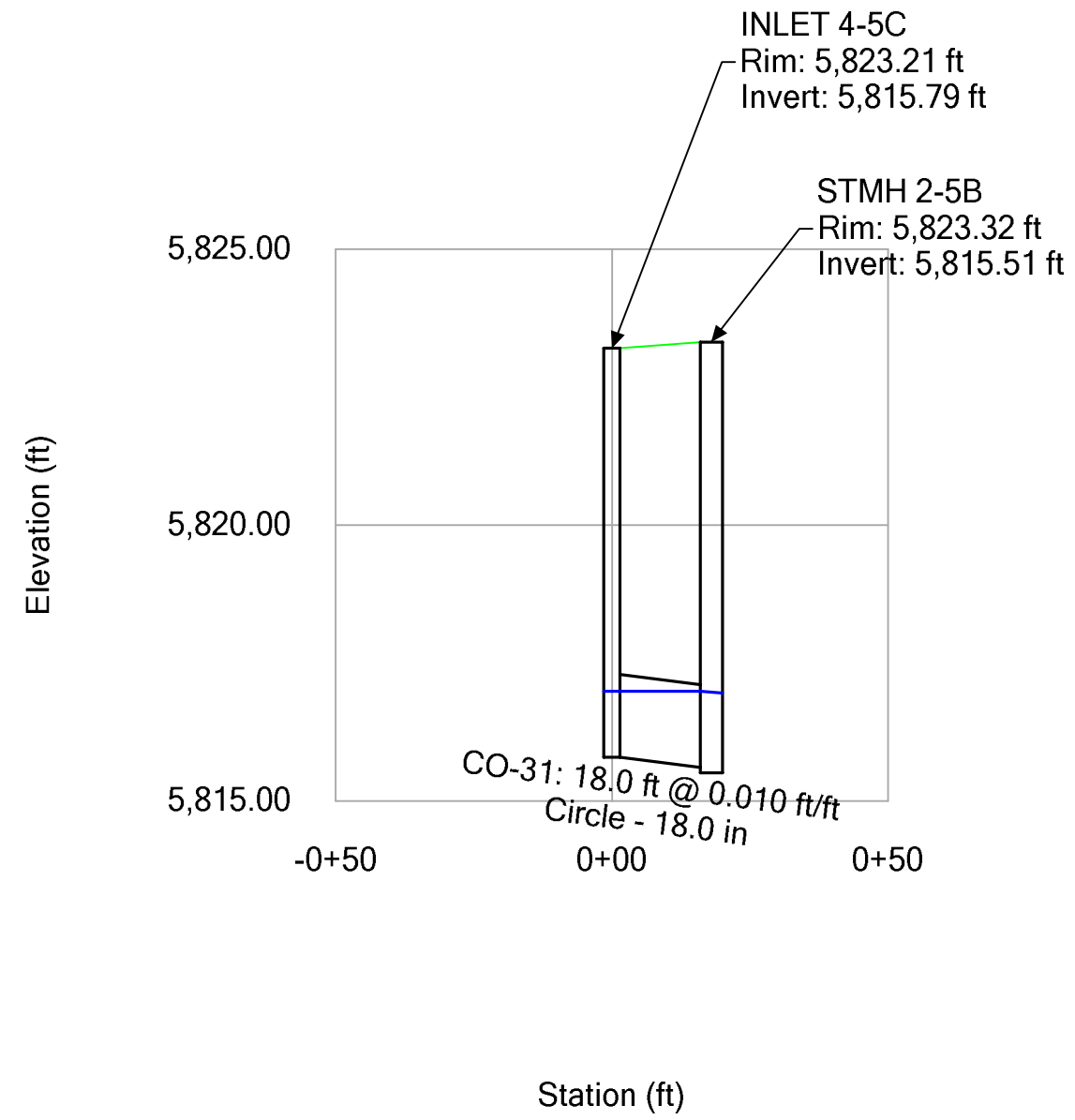

Profile Report
Engineering Profile - Profile - Storm Line 5G (Compark Village South StormCAD [100 year].stsw)

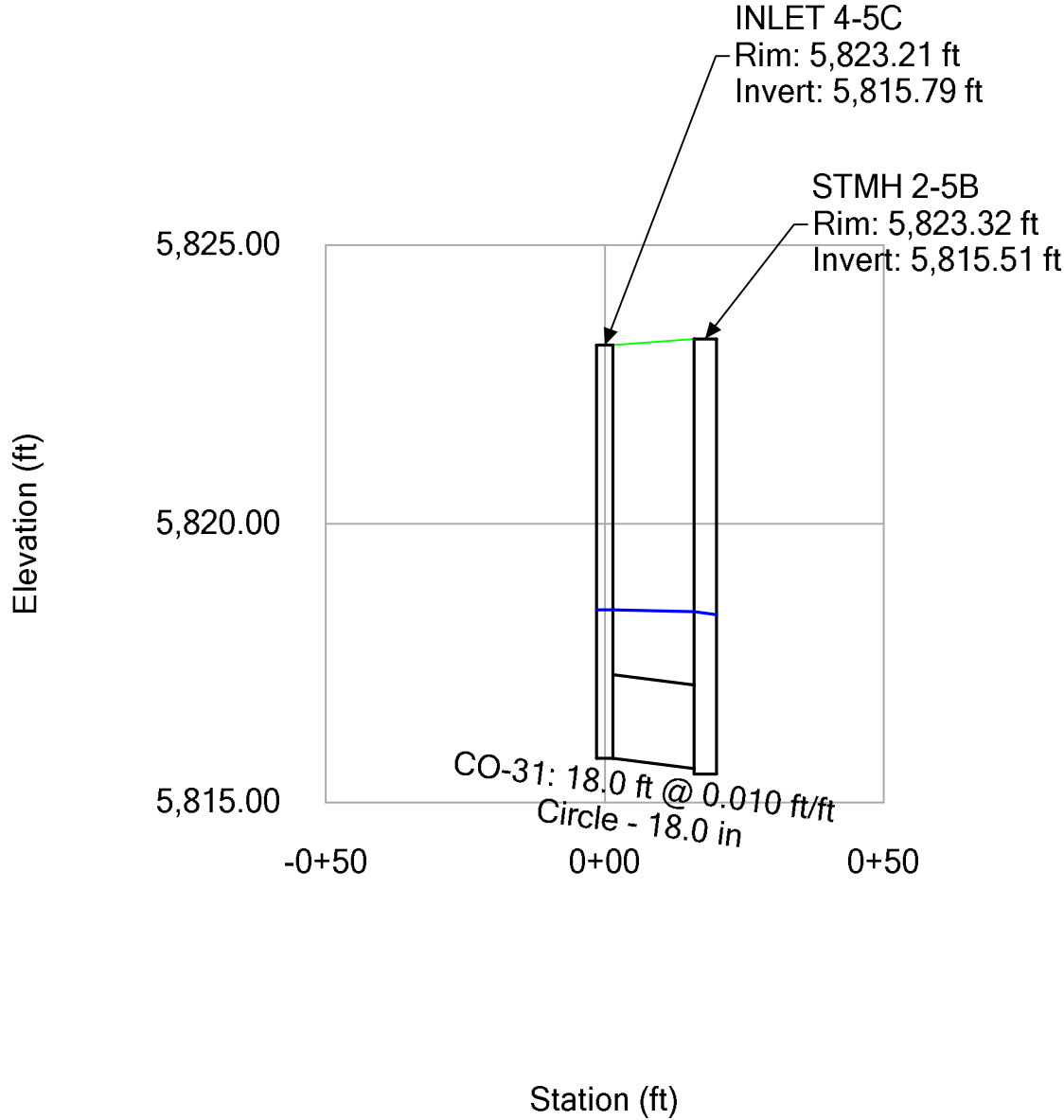

Profile Report
Engineering Profile - Profile - Storm Line 5H (Compark Village South StormCAD [2 year].stsw)

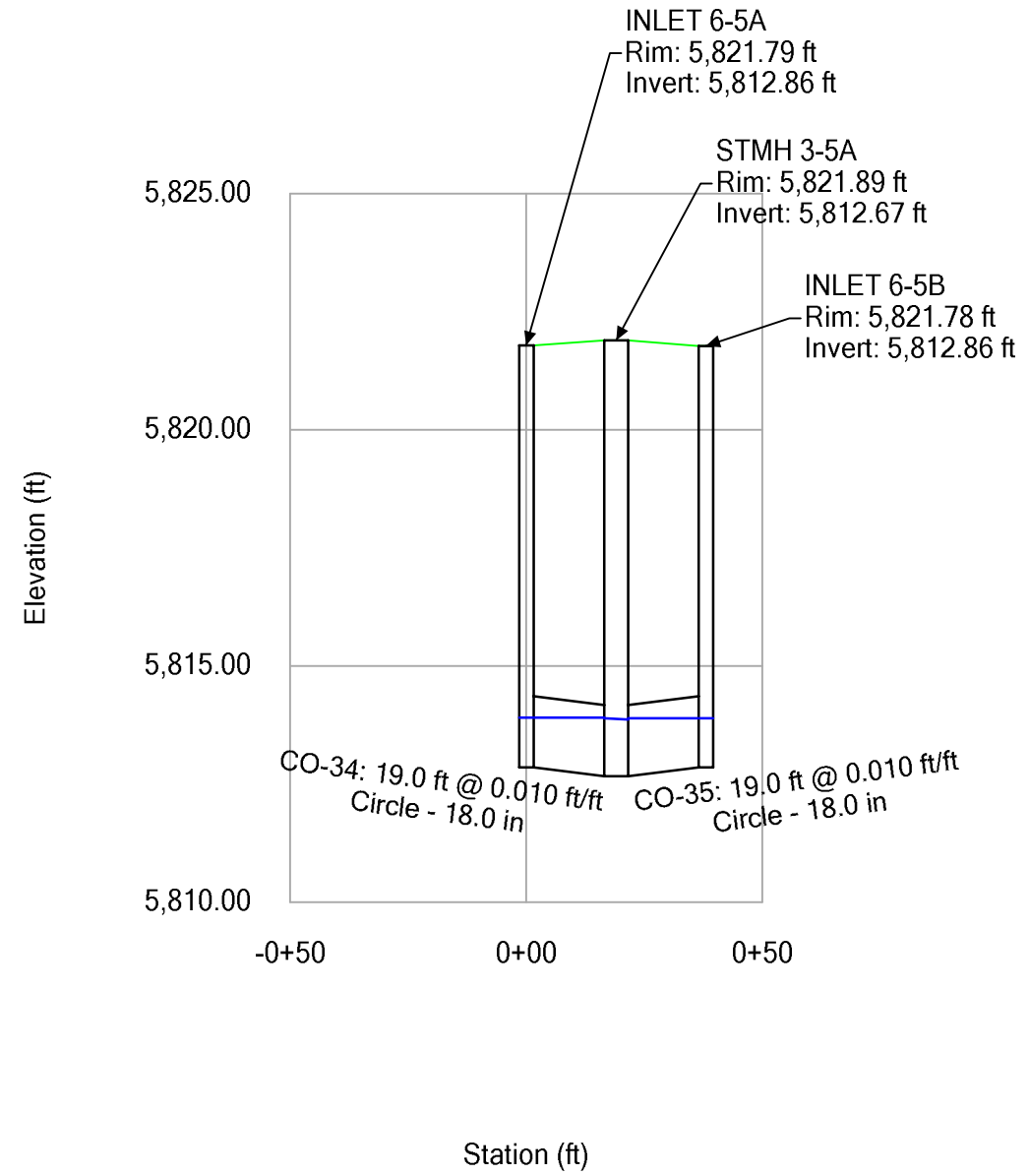

Profile Report
Engineering Profile - Profile - Storm Line 5H (Compark Village South StormCAD [5 year].stsw)

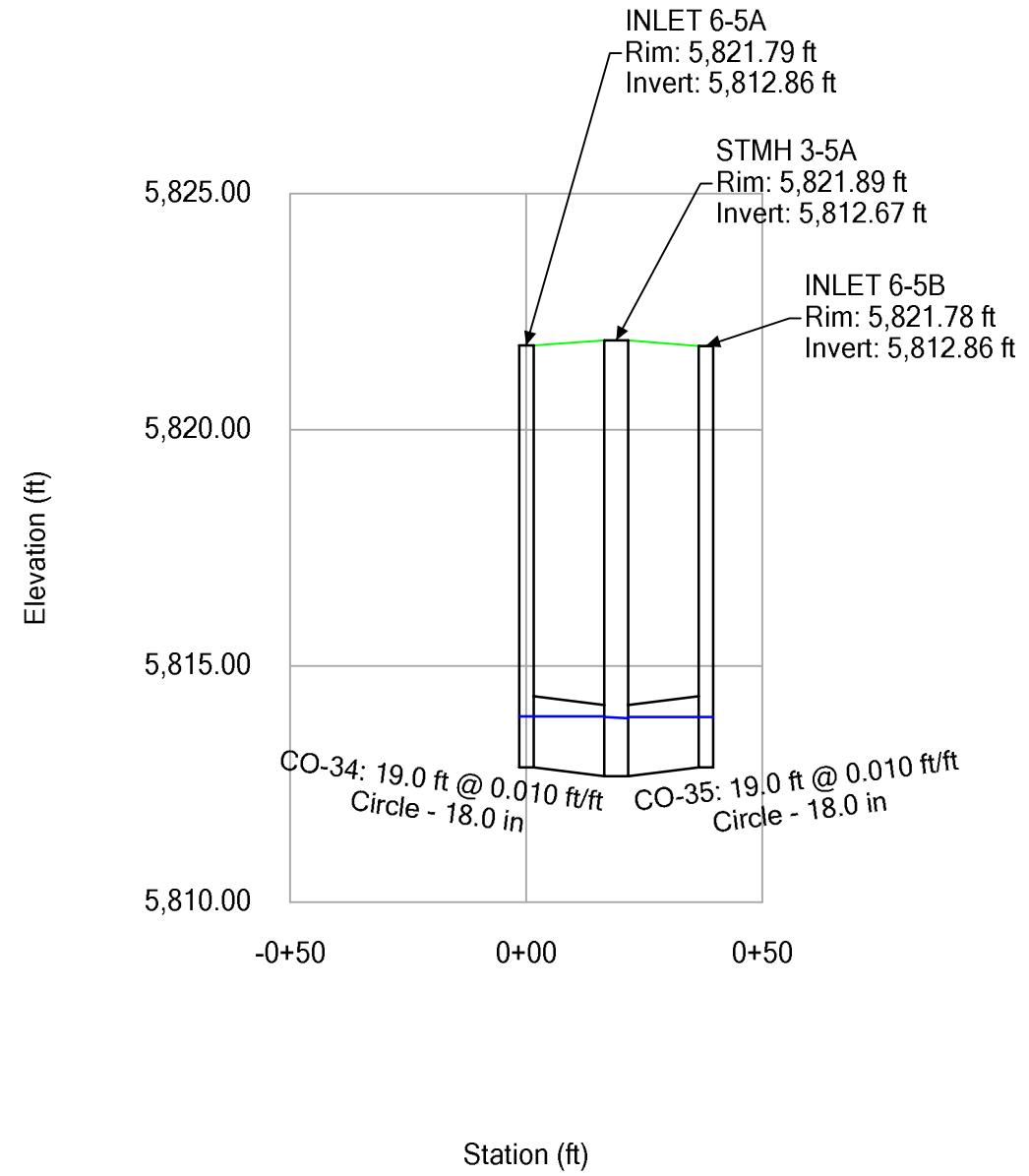

Profile Report
Engineering Profile - Profile - Storm Line 5H (Compark Village South StormCAD [100 year].stsw)

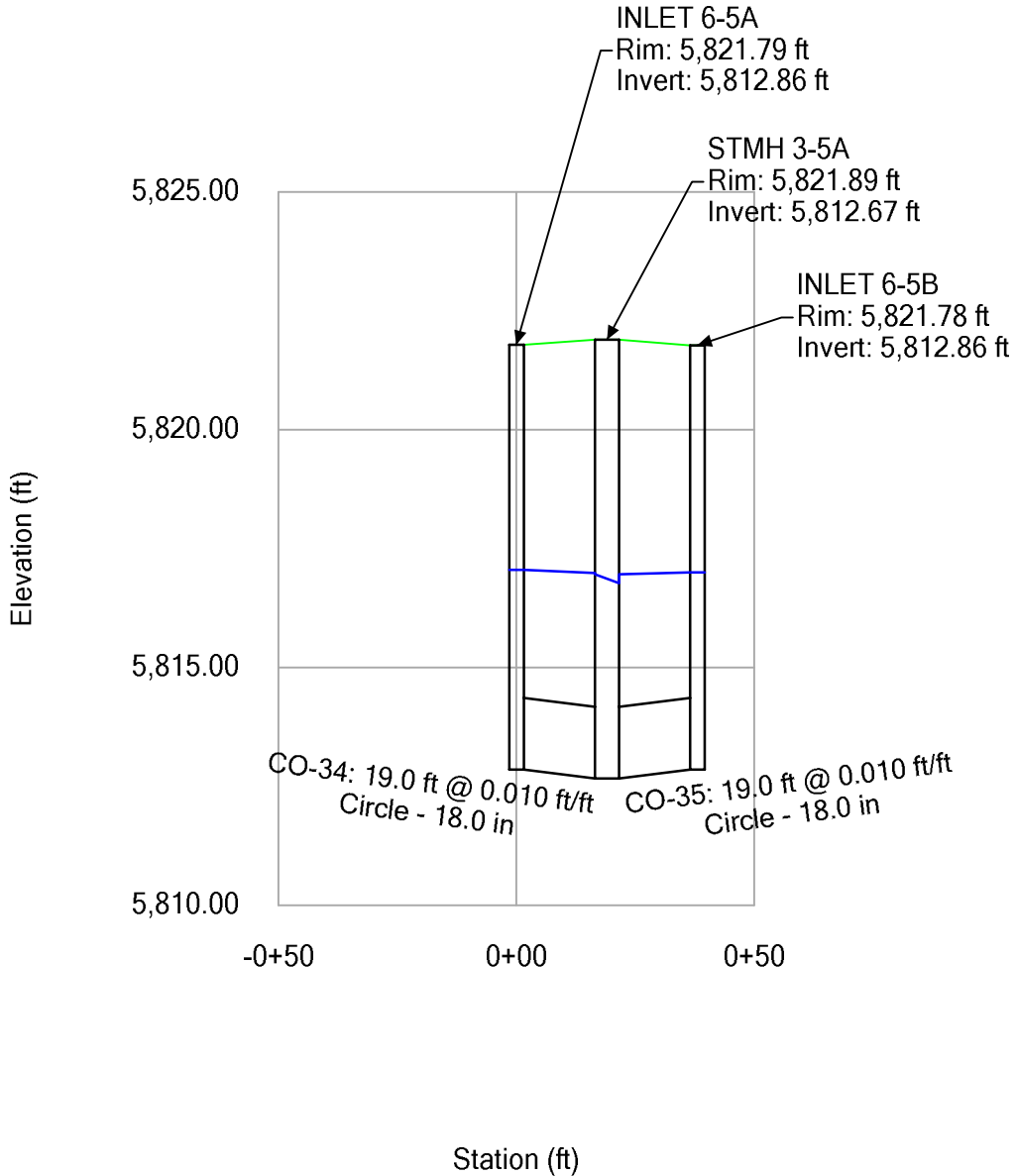

Profile Report
 Engineering Profile - Profile - Storm 9 (072020 Compark Village South StormCAD [2 year].stsw)

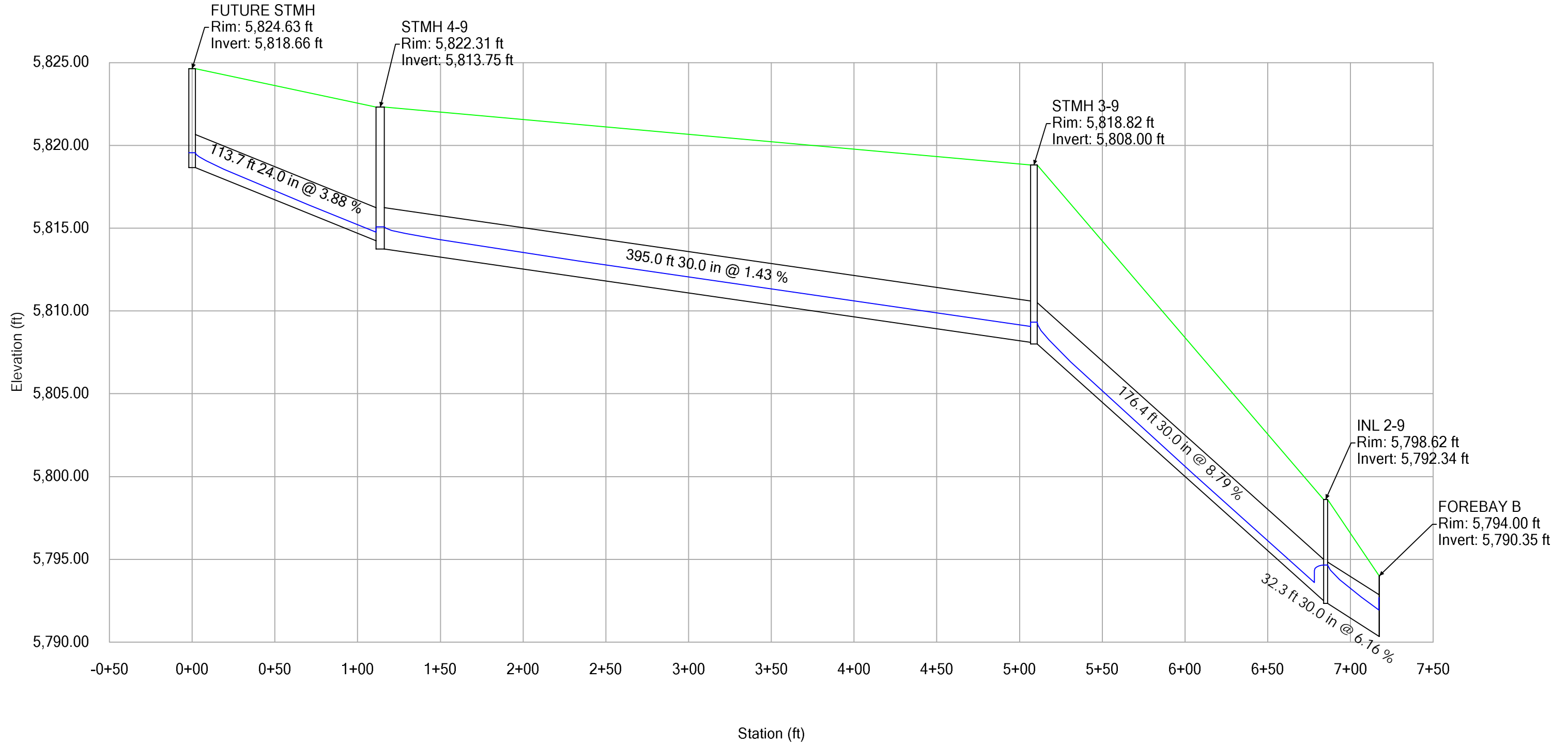

Profile Report

Engineering Profile - Profile - Storm Line 9 (072020 Compark Village South StormCAD [5 year].stsw)

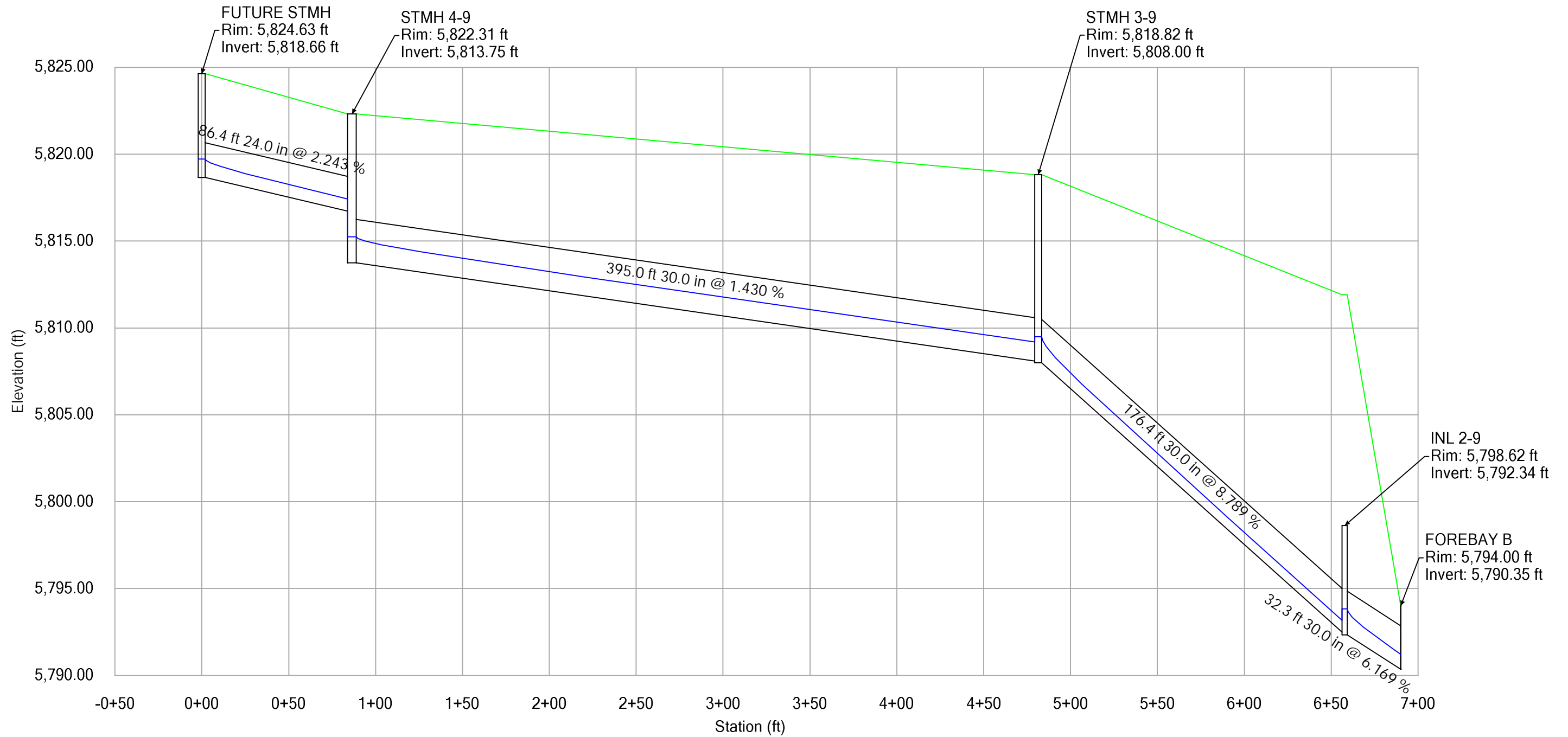

Profile Report

Engineering Profile - Profile - Storm Line 9 (072020 Compark Village South StormCAD [100 year].stsw)

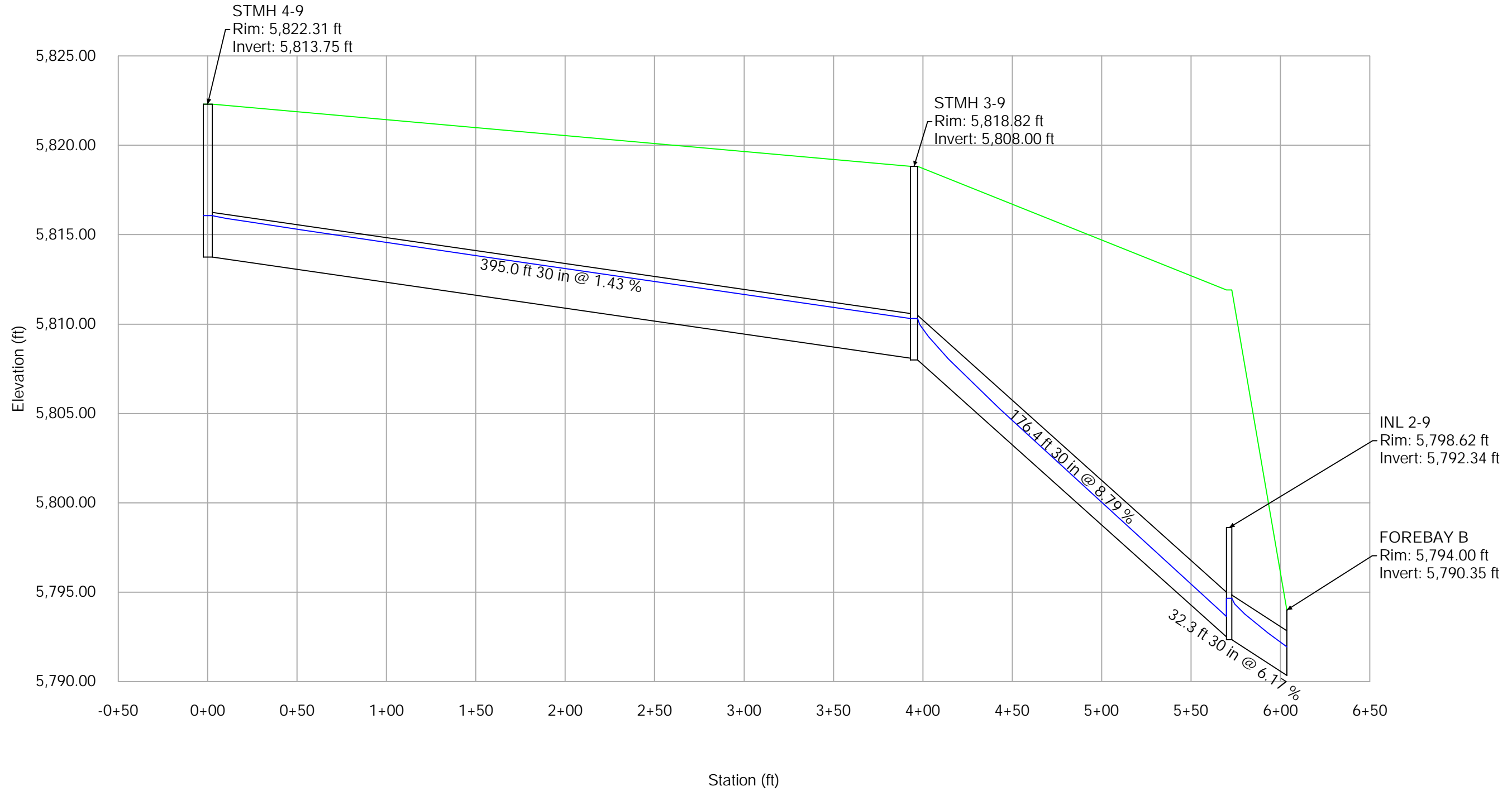

Profile Report

Engineering Profile - Profile - Storm 10 (072020 Compark Village South StormCAD [2 year].stsw)

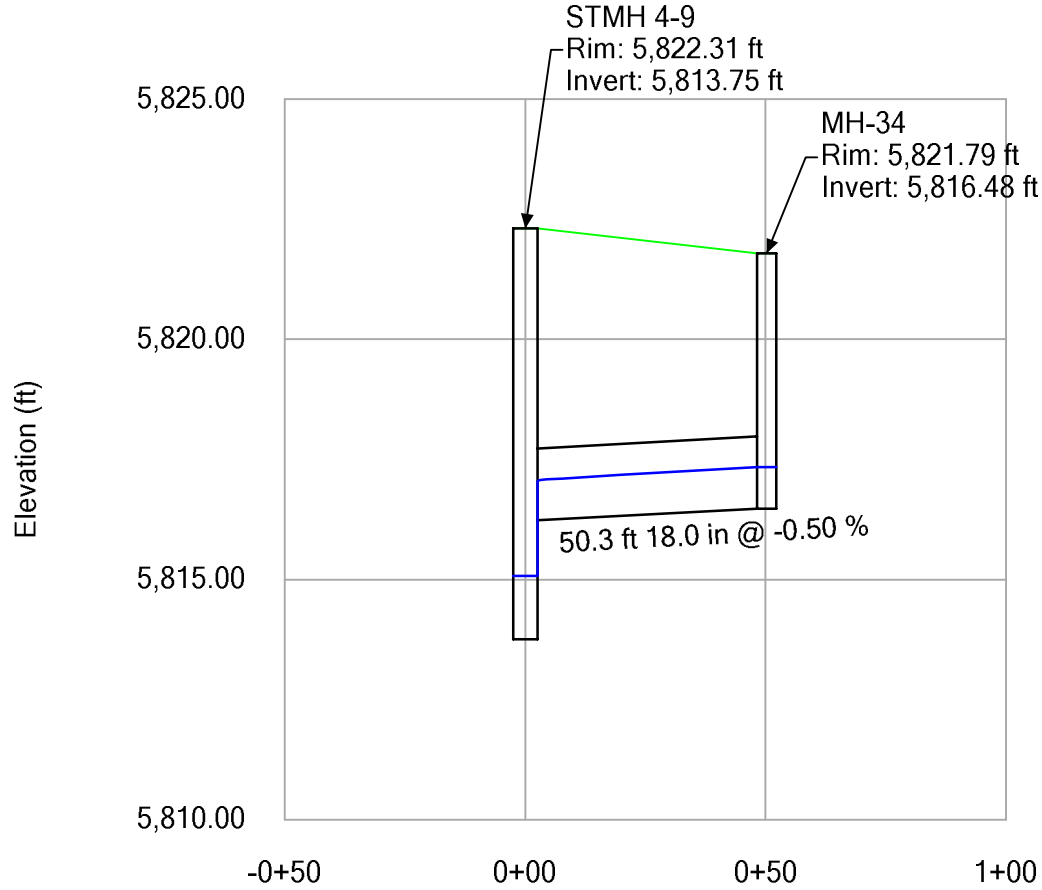

Profile Report

Engineering Profile - Profile -Storm Line 10 (072020 Compark Village South StormCAD [5 year].stsw)

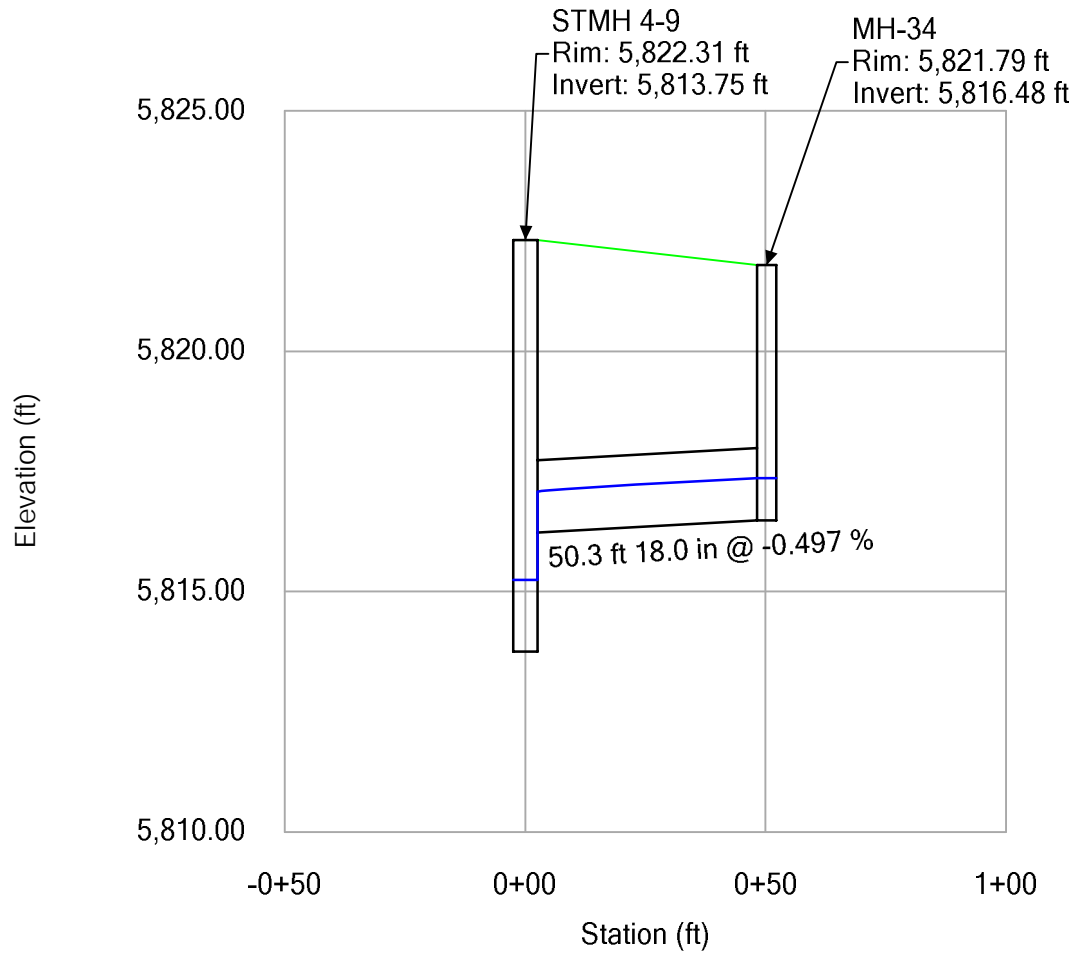

Profile Report

Engineering Profile - Profile - Storm Line 10 (072020 Compark Village South StormCAD [100 year].stsw)

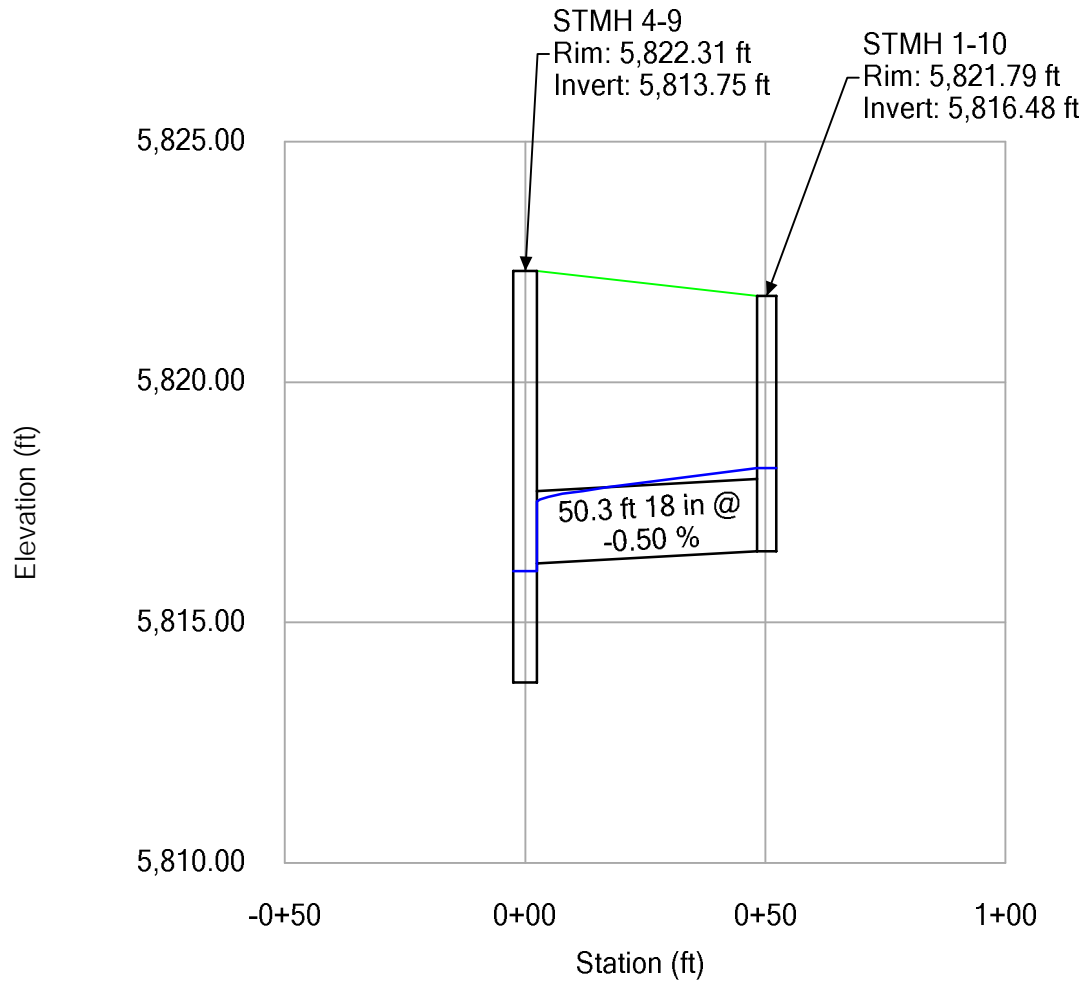

Profile Report

Engineering Profile - Profile - Storm 10A (072020 Compark Village South StormCAD [2 year].stsw)

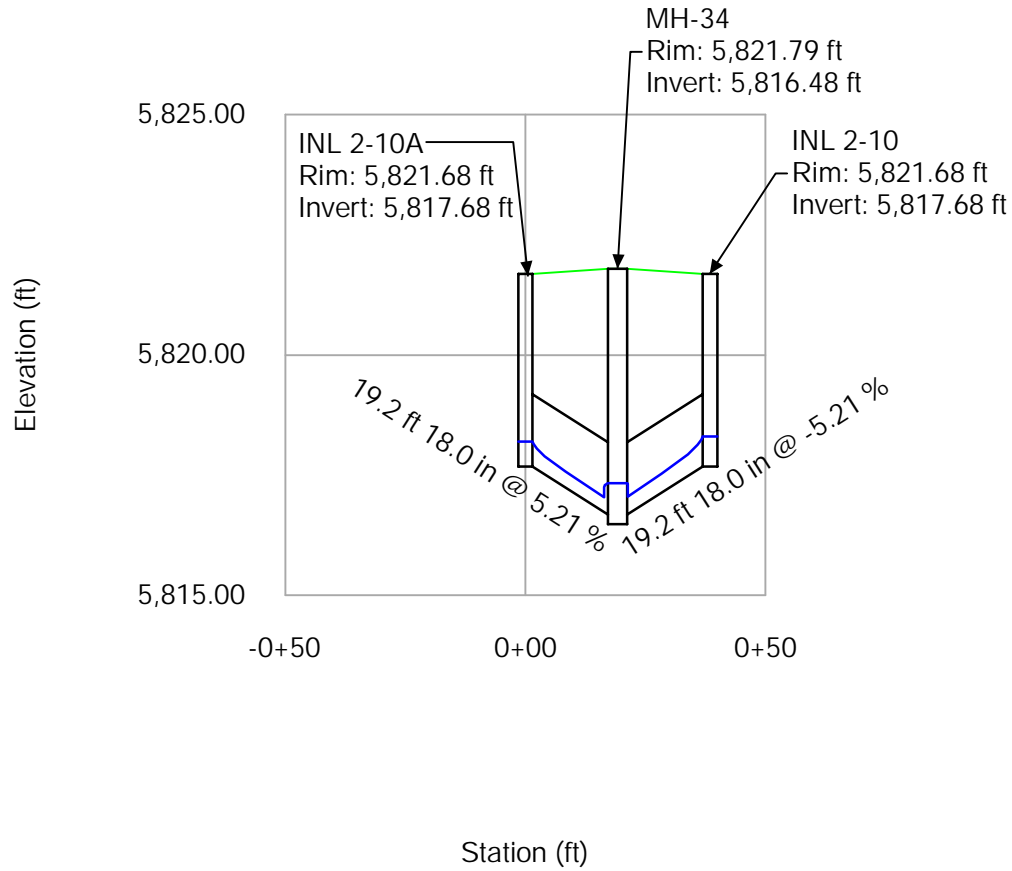

Profile Report

Engineering Profile - Profile - Storm Line 10A (072020 Compark Village South StormCAD [5 year].stsw)

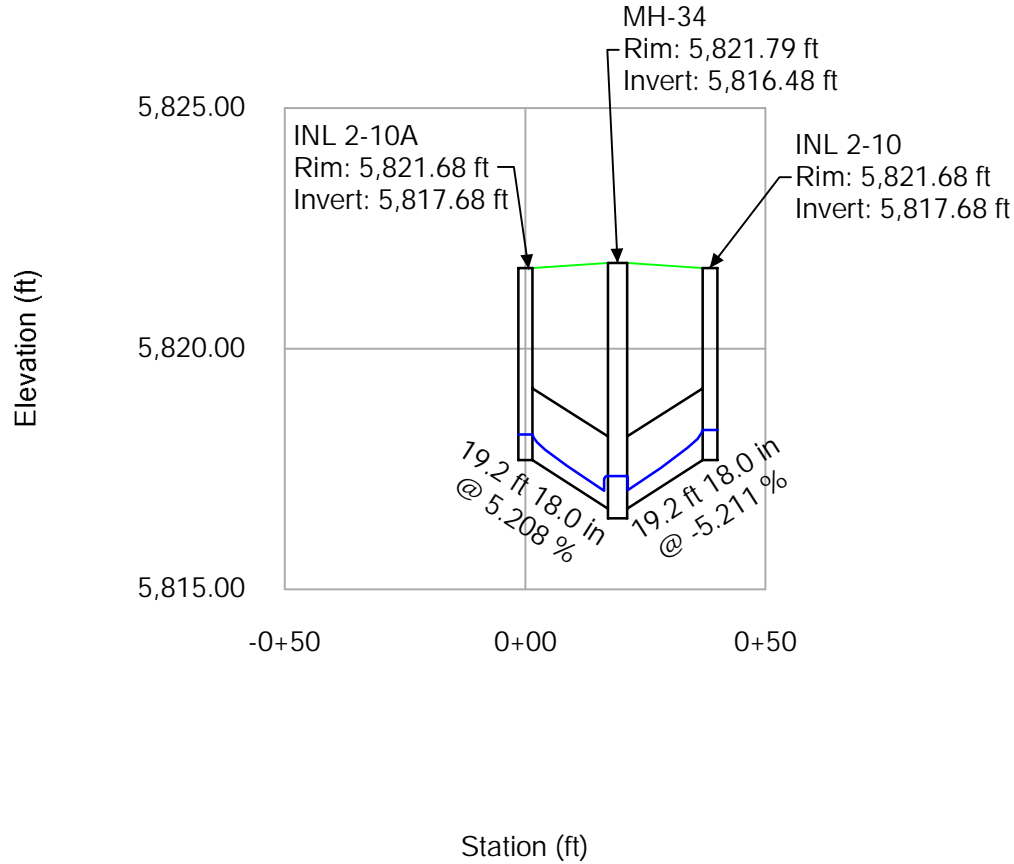

Profile Report

Engineering Profile - Profile - Storm Line 10A (072020 Compark Village South StormCAD [100 year].stsw)

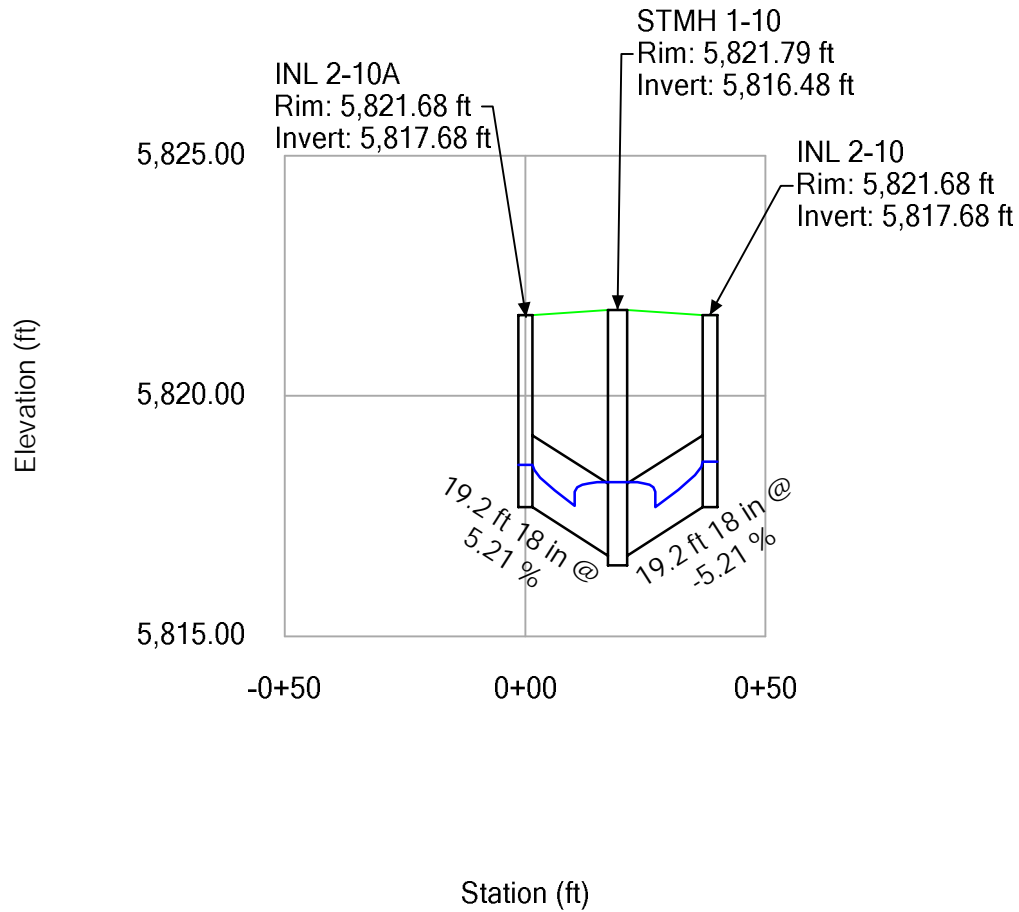

Profile Report

Engineering Profile - Profile - Storm 11 (072020 Compark Village South StormCAD [2 year].stsw)

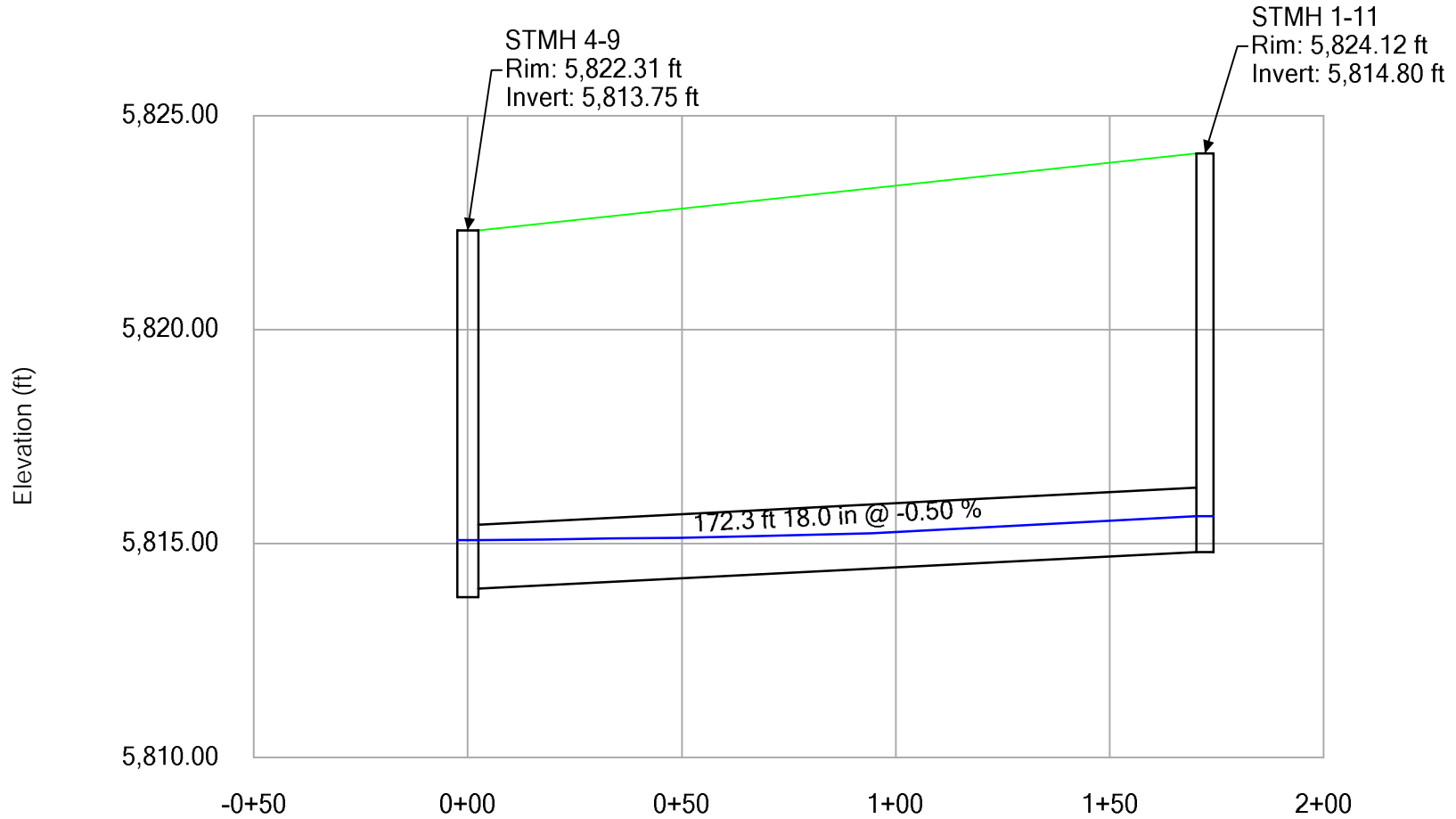

Profile Report

Engineering Profile - Profile - Storm Line 11 (072020 Compark Village South StormCAD [5 year].stsw)

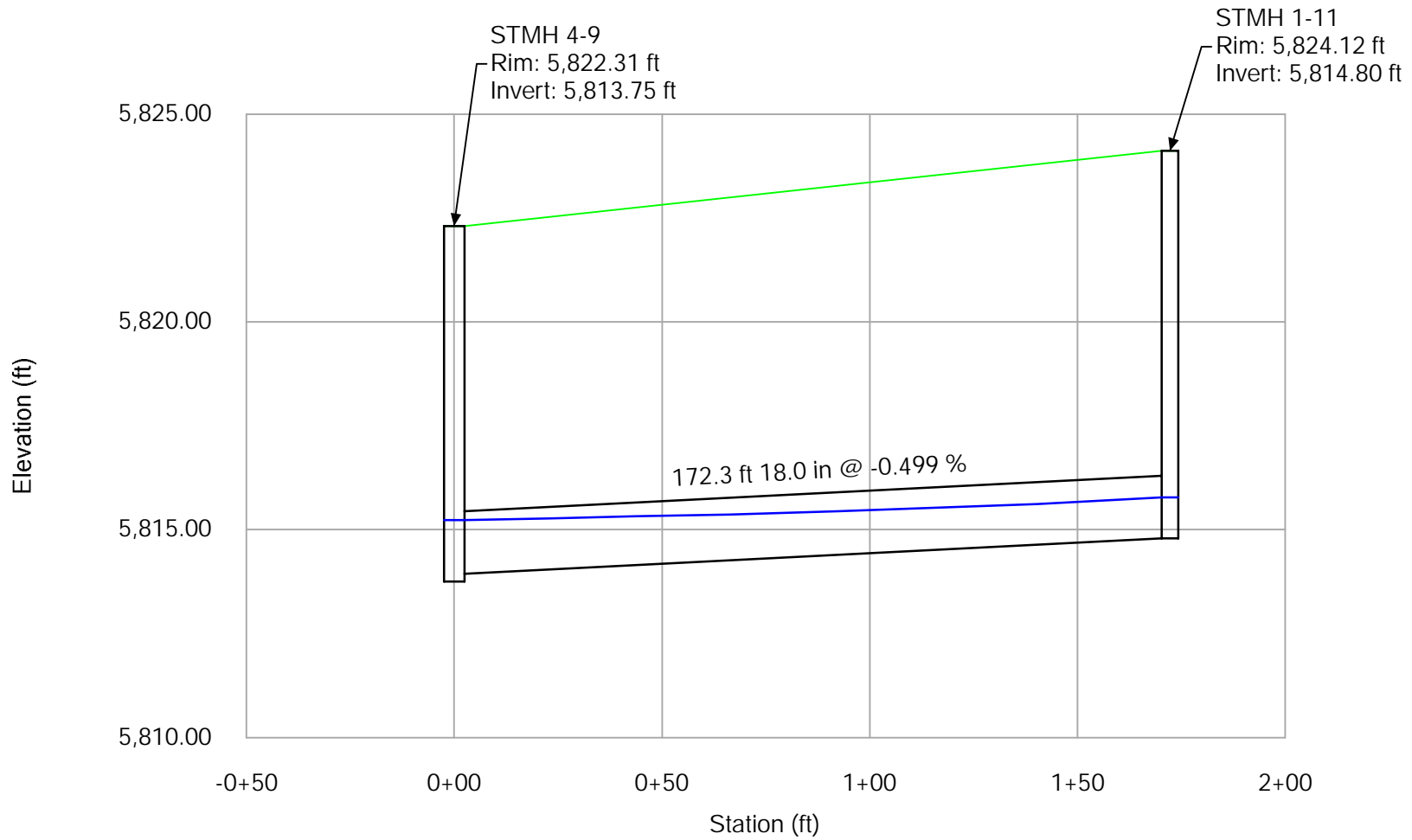

Profile Report

Engineering Profile - Profile - Storm Line 11 (072020 Compark Village South StormCAD [100 year].stsw)

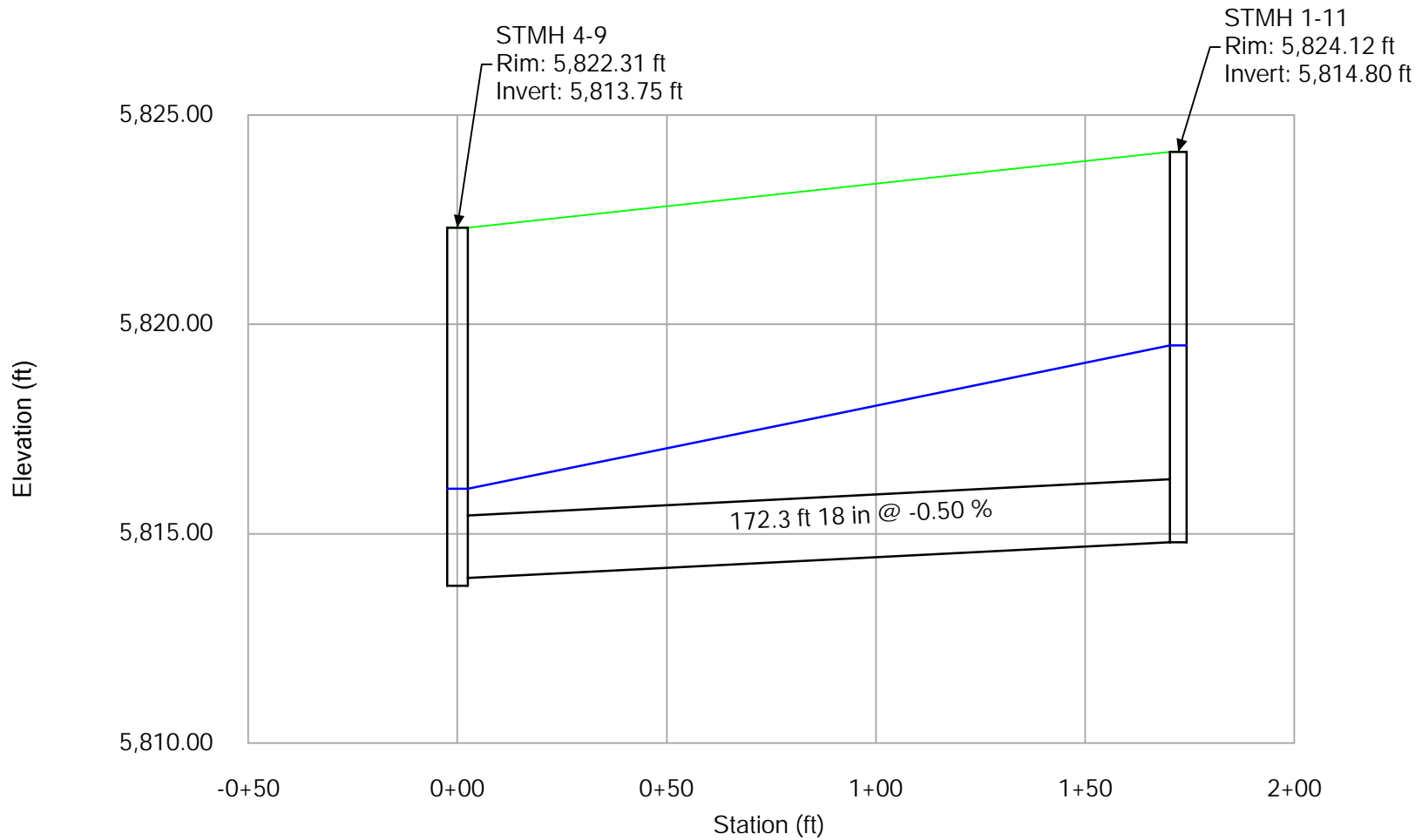

Profile Report

Engineering Profile - Profile - Storm 11A (072020 Compark Village South StormCAD [2 year].stsw)

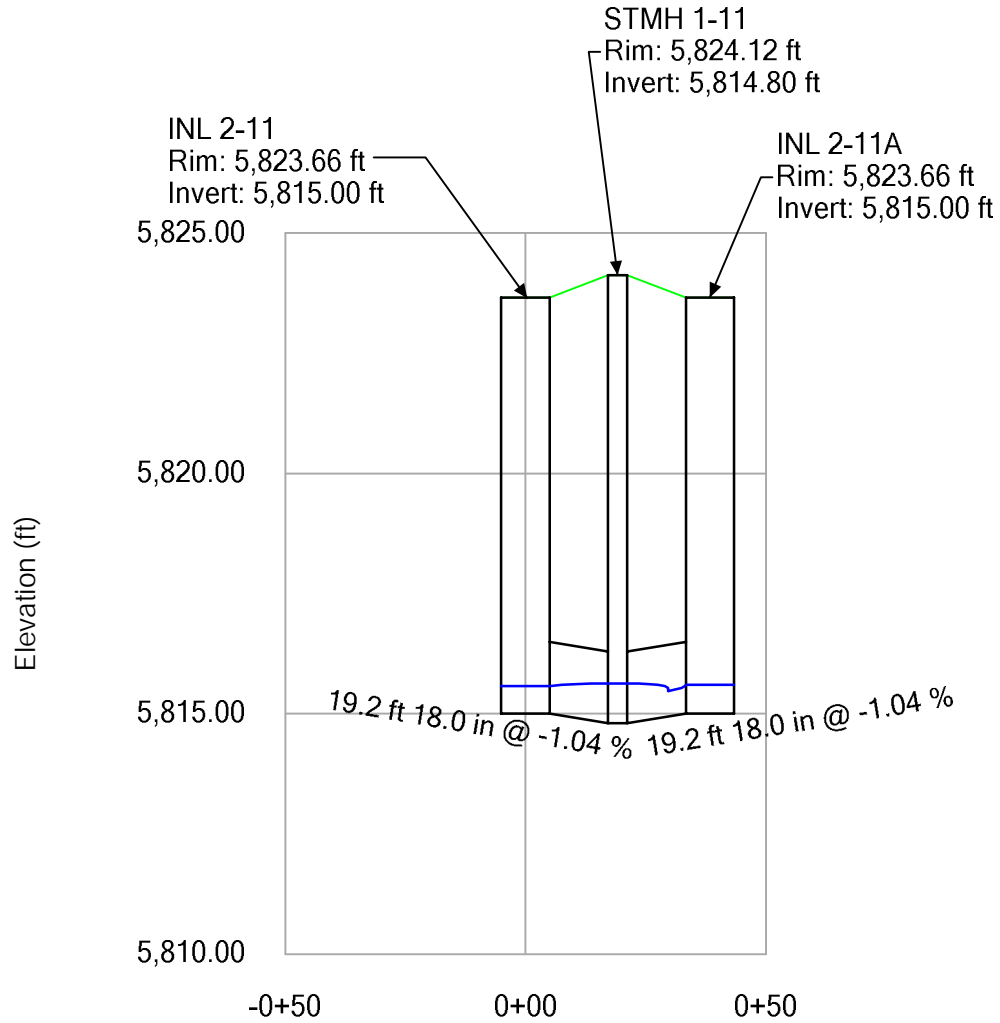

Profile Report

Engineering Profile - Profile - Storm Line 11A (072020 Compark Village South StormCAD [5 year].stsw)

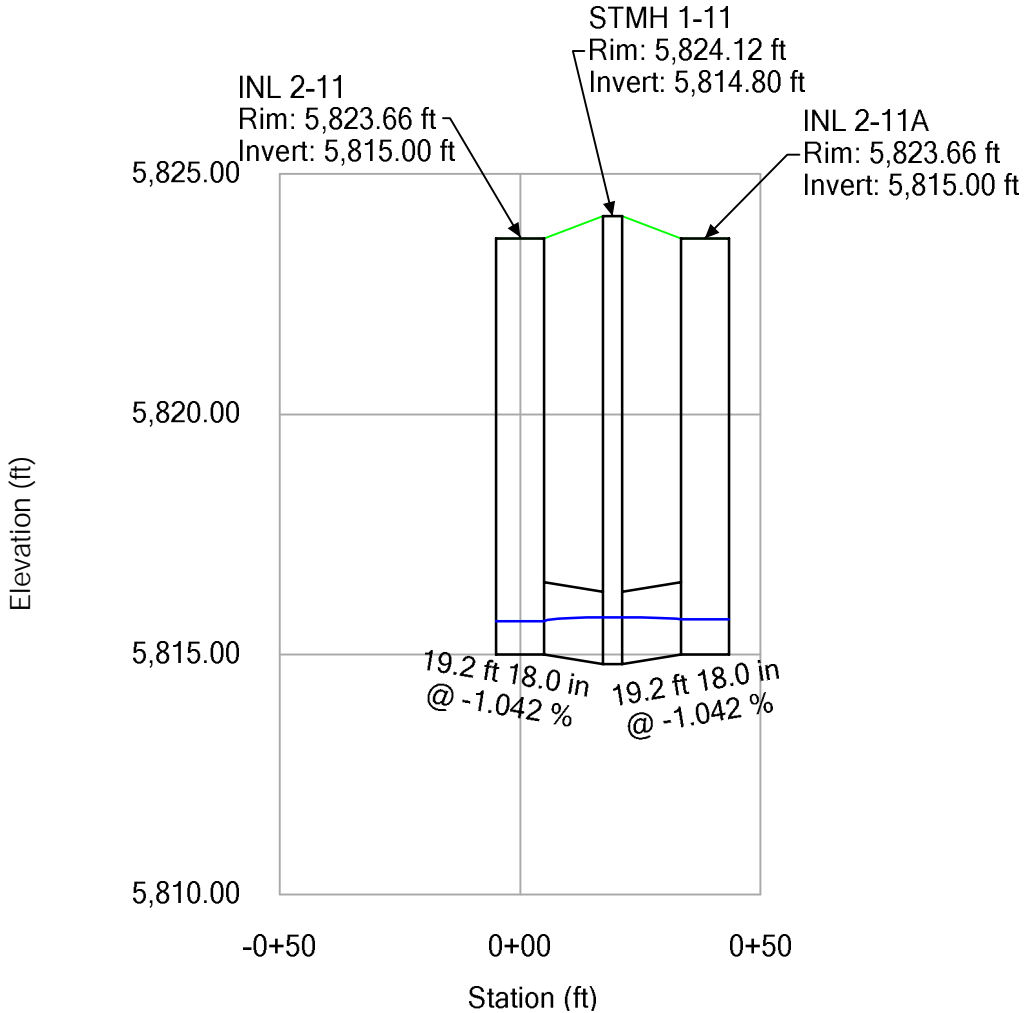

Profile Report

Engineering Profile - Profile -Storm Line 11A (072020 Compark Village South StormCAD [100 year].stsw)

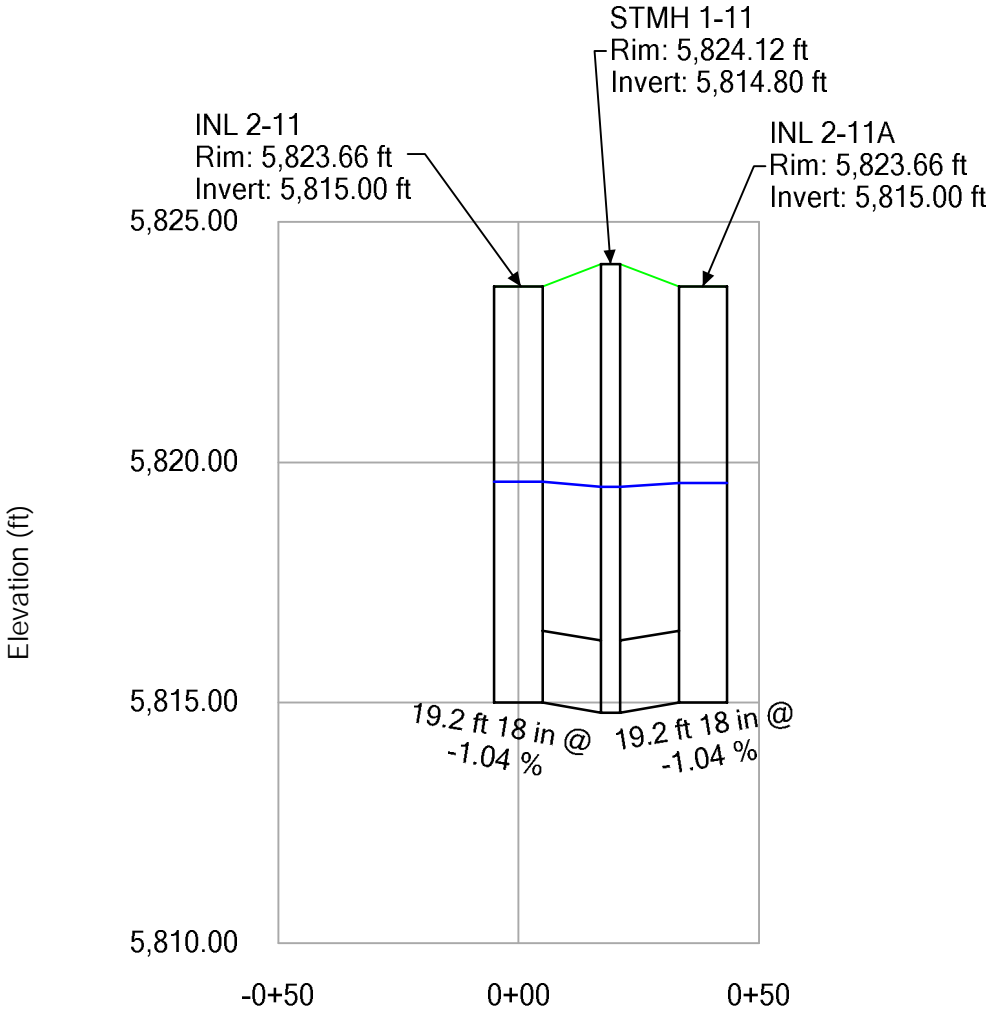

FlexTable: Conduit Table 2 YR STORM EVENT

Start Node	Invert (Start) (ft)	Stop Node	Invert (Stop) (ft)	Length (User Defined) (ft)	Slope (Calculated) (%)	Section Type	Diameter (in)	Manning's n	Flow (cfs)	Velocity (ft/s)	Hydraulic Grade Line (In) (ft)	Hydraulic Grade Line (Out) (ft)
STMH 6-4	5,834.91	INLET 6-4	5,832.53	120.0	1.98	Circle	36.0	0.013	8.50	8.25	5,835.83	5,833.14
INLET 6-4	5,832.33	STMH 5-4	5,827.71	278.0	1.66	Circle	36.0	0.013	9.60	8.03	5,833.31	5,828.39
FES 2-5	5,834.54	INLET 8-5	5,834.00	7.7	7.01	Circle	24.0	0.013	4.10	10.91	5,835.25	5,834.45
INLET 5-4	5,829.34	STMH 5-4	5,828.83	52.0	0.99	Circle	18.0	0.013	3.40	5.28	5,830.05	5,829.42
INLET 3-4	5,825.42	STMH 4-4	5,825.23	20.0	0.95	Circle	18.0	0.013	3.90	5.40	5,826.18	5,825.89
INLET 1-4	5,823.04	STMH 2-4	5,821.92	65.0	1.72	Circle	18.0	0.013	2.30	5.79	5,823.61	5,822.33
INLET 4-4	5,825.42	STMH 4-4	5,825.23	20.0	0.95	Circle	18.0	0.013	0.90	3.57	5,825.77	5,825.53
INLET 2-6	5,814.55	INLET 1-6	5,814.15	80.0	0.50	Circle	18.0	0.013	2.90	3.94	5,815.20	5,814.96
INLET 2-3	5,836.69	INLET 1-3	5,831.04	94.0	6.01	Circle	24.0	0.013	4.20	10.40	5,837.41	5,831.41
FES 2-4	5,842.00	STMH 6-4	5,835.11	221.0	3.12	Circle	36.0	0.013	8.50	9.68	5,842.92	5,835.66
STMH 5-4	5,827.41	STMH 4-4	5,822.96	163.0	2.73	Circle	36.0	0.013	14.00	10.69	5,828.60	5,823.68
INLET 4-5	5,812.96	STMH 2-5A	5,812.27	19.0	3.63	Circle	18.0	0.013	2.40	7.64	5,813.55	5,813.63
INLET 5-5	5,813.90	STMH 2-5	5,811.47	49.0	4.96	Circle	18.0	0.013	3.30	9.35	5,814.59	5,813.40
STMH 4-4	5,822.16	STMH 3-4	5,821.56	79.0	0.76	Circle	36.0	0.013	18.80	7.34	5,823.55	5,822.99
STMH 3-4	5,821.46	STMH 2-4	5,820.65	76.0	1.07	Circle	36.0	0.013	21.30	8.59	5,822.94	5,821.82
INLET 2-4	5,822.07	STMH 3-4	5,821.56	56.0	0.91	Circle	18.0	0.013	2.50	4.71	5,822.96	5,822.97
STMH 1-6	5,806.20	FES1-6	5,806.00	40.0	0.50	Circle	24.0	0.013	0.00	0.00	5,806.20	5,806.00
INLET 8-5	5,833.51	INLET 7-5	5,827.49	173.0	3.48	Circle	24.0	0.013	4.10	8.52	5,834.22	5,827.91
INLET 4-5A	5,821.14	STMH 2-5E	5,820.90	20.0	1.20	Circle	18.0	0.013	4.10	5.96	5,821.92	5,821.91
INLET 5-5A	5,821.14	STMH 2-5E	5,820.90	20.0	1.20	Circle	18.0	0.013	4.20	6.00	5,821.93	5,821.91
STMH 2-5	5,811.37	INLET 3-5	5,810.99	16.0	2.38	Circle	42.0	0.013	36.10	13.13	5,813.23	5,812.45
INLET 7-5	5,827.14	STMH 4-5	5,822.27	104.6	4.66	Circle	24.0	0.013	4.30	9.57	5,827.87	5,823.07
STMH 4-5	5,822.27	INLET 6-5	5,821.44	23.0	3.61	Circle	24.0	0.013	4.30	8.75	5,823.00	5,822.20
STMH 2-5A	5,812.17	STMH 2-5	5,811.47	50.0	1.40	Circle	36.0	0.013	20.00	9.32	5,813.60	5,813.41
STMH 2-5B	5,815.51	STMH 2-5A	5,812.17	241.0	1.39	Circle	30.0	0.013	17.60	9.06	5,816.93	5,813.65
STMH 1-4	5,818.23	FES 1-4	5,818.00	46.0	0.50	Circle	36.0	0.013	0.00	0.00	5,818.23	5,818.00
INLET 1-3	5,829.94	STMH 1-3	5,829.37	18.4	3.10	Circle	24.0	0.013	8.90	10.21	5,831.00	5,830.87
STMH 1-3	5,829.37	O-1	5,829.00	12.0	3.08	Circle	24.0	0.013	8.90	10.19	5,830.85	5,830.90
INLET 5-4A	5,829.26	STMH 5-4	5,828.83	43.0	1.00	Circle	18.0	0.013	1.00	3.75	5,829.63	5,829.14
STMH 2-5E	5,820.80	STMH 2-5D	5,820.12	44.0	1.55	Circle	24.0	0.013	8.30	7.79	5,821.83	5,821.42
STMH 2-5D	5,820.12	STMH 2-5C	5,819.49	45.0	1.40	Circle	24.0	0.013	11.80	8.25	5,821.35	5,820.86
STMH 2-5C	5,819.49	STMH 2-5B	5,815.51	289.0	1.38	Circle	30.0	0.013	15.20	8.69	5,820.81	5,816.97
INLET 4-5B	5,819.70	STMH 2-5C	5,819.52	18.0	1.00	Circle	18.0	0.013	3.40	5.30	5,820.85	5,820.85
INLET 5-5B	5,828.30	STMH 2-5D	5,820.22	293.0	2.76	Circle	18.0	0.013	3.50	7.71	5,829.01	5,821.43
INLET 4-5C	5,815.79	STMH 2-5B	5,815.61	18.0	1.00	Circle	18.0	0.013	2.40	4.82	5,816.96	5,816.96
INLET 6-5	5,821.14	STMH 3-5A	5,812.67	247.0	3.43	Circle	30.0	0.013	8.20	10.12	5,822.09	5,813.92
STMH 3-5A	5,812.67	STMH 2-5	5,811.37	48.0	2.71	Circle	30.0	0.013	12.80	10.58	5,813.87	5,813.31
INLET 6-5A	5,812.86	STMH 3-5A	5,812.67	19.0	1.00	Circle	18.0	0.013	2.60	4.93	5,813.90	5,813.91
INLET 6-5B	5,812.86	STMH 3-5A	5,812.67	19.0	1.00	Circle	18.0	0.013	2.00	4.58	5,813.90	5,813.90
INLET 1-6	5,814.05	DIVERSION - STMH 8-12	5,813.06	16.0	6.19	Circle	24.0	0.013	5.80	11.56	5,814.90	5,813.57
STMH 1-12	5,820.16	STMH 2-12	5,819.90	52.0	0.50	Circle	30.0	0.013	23.60	6.58	5,822.55	5,822.40
STMH 2-12	5,819.80	STMH 3-12	5,818.95	168.0	0.51	Circle	30.0	0.013	23.60	6.62	5,821.51	5,820.65
STMH 3-12	5,818.85	STMH 4-12	5,817.87	196.0	0.50	Circle	30.0	0.013	23.60	6.58	5,820.56	5,819.57
STMH 4-12	5,817.77	STMH 5-12	5,816.76	202.0	0.50	Circle	30.0	0.013	23.60	6.58	5,819.48	5,818.41
STMH 5-12	5,816.66	STMH 6-12	5,808.94	286.0	2.70	Circle	30.0	0.013	23.60	12.51	5,818.31	5,811.37
STMH 7-12	5,812.68	STMH 6-12	5,812.33	70.0	0.50	Circle	18.0	0.013	5.80	4.65	5,813.68	5,813.26
INLET 2-5	5,808.00	STMH 10-12	5,807.36	27.0	2.37	Circle	24.0	0.013	7.90	8.97	5,809.29	5,809.36
STMH 10-12	5,807.36	INLET 1-5	5,808.34	67.9	-1.44	Circle	24.0	0.013	4.90	6.56	5,809.28	5,809.36

FlexTable: Conduit Table 5 YR STORM EVENT

Start Node	Invert (Start) (ft)	Stop Node	Invert (Stop) (ft)	Length (User Defined) (ft)	Slope (Calculated) (%)	Section Type	Diameter (in)	Manning's n	Flow (cfs)	Velocity (ft/s)	Hydraulic Grade Line (In) (ft)	Hydraulic Grade Line (Out) (ft)
STMH 6-4	5,834.91	INLET 6-4	5,832.53	120.0	1.983	Circle	36.0	0.013	8.50	8.25	5,835.83	5,833.14
INLET 6-4	5,832.33	STMH 5-4	5,827.71	278.0	1.662	Circle	36.0	0.013	9.60	8.03	5,833.31	5,828.39
FES 2-5	5,834.54	INLET 8-5	5,834.00	7.7	7.013	Circle	24.0	0.013	4.10	10.91	5,835.25	5,834.45
INLET 5-4	5,829.34	STMH 5-4	5,828.83	52.0	0.989	Circle	18.0	0.013	3.60	5.37	5,830.07	5,829.44
INLET 3-4	5,825.42	STMH 4-4	5,825.23	20.0	0.950	Circle	18.0	0.013	4.00	5.44	5,826.19	5,825.89
INLET 1-4	5,823.04	STMH 2-4	5,821.92	65.0	1.723	Circle	18.0	0.013	2.40	5.86	5,823.63	5,822.34
INLET 4-4	5,825.42	STMH 4-4	5,825.23	20.0	0.950	Circle	18.0	0.013	0.90	3.57	5,825.77	5,825.53
INLET 2-6	5,813.03	INLET 1-6	5,811.92	80.0	1.388	Circle	24.0	0.013	3.00	5.61	5,813.63	5,812.65
INLET 2-5	5,808.09	INLET 1-5	5,807.49	90.0	0.669	Circle	36.0	0.013	8.20	5.56	5,809.00	5,808.81
INLET 1-5	5,807.29	STMH 1-5	5,806.51	103.0	0.757	Circle	36.0	0.013	13.30	6.66	5,808.68	5,808.76
STMH 1-5	5,805.81	FES 1-5	5,793.00	446.0	2.872	Circle	42.0	0.013	55.71	15.85	5,808.15	5,794.38
INLET 2-3	5,840.56	INLET 1-3	5,831.04	94.0	10.128	Circle	24.0	0.013	4.50	12.77	5,841.31	5,831.38
FES 2-4	5,842.00	STMH 6-4	5,835.11	221.0	3.118	Circle	36.0	0.013	8.50	9.68	5,842.92	5,835.66
STMH 5-4	5,827.41	STMH 4-4	5,822.96	163.0	2.730	Circle	36.0	0.013	14.30	10.75	5,828.61	5,823.69
INLET 4-5	5,812.96	STMH 2-5A	5,812.27	19.0	3.632	Circle	18.0	0.013	2.50	7.73	5,813.56	5,813.65
INLET 5-5	5,813.90	STMH 2-5	5,811.47	49.0	4.959	Circle	18.0	0.013	3.40	9.43	5,814.60	5,813.44
STMH 4-4	5,822.16	STMH 3-4	5,821.56	79.0	0.759	Circle	36.0	0.013	19.20	7.38	5,823.56	5,823.01
STMH 3-4	5,821.46	STMH 2-4	5,820.65	76.0	1.066	Circle	36.0	0.013	21.80	8.64	5,822.96	5,822.19
INLET 2-4	5,822.07	STMH 3-4	5,821.56	56.0	0.911	Circle	18.0	0.013	2.60	4.76	5,822.98	5,822.99
INLET 1-6	5,811.72	STMH 1-6	5,810.35	133.0	1.030	Circle	24.0	0.013	6.00	6.15	5,812.59	5,811.05
STMH 1-6	5,810.25	FES1-6	5,810.00	50.0	0.500	Circle	24.0	0.013	6.00	4.73	5,811.12	5,810.85
INLET 8-5	5,833.51	INLET 7-5	5,827.49	173.0	3.480	Circle	24.0	0.013	4.10	8.52	5,834.22	5,827.91
INLET 4-5A	5,821.14	STMH 2-5E	5,820.90	20.0	1.200	Circle	18.0	0.013	4.30	6.04	5,821.94	5,821.93
INLET 5-5A	5,821.14	STMH 2-5E	5,820.90	20.0	1.200	Circle	18.0	0.013	4.30	6.04	5,821.94	5,821.93
STMH 2-5	5,811.37	INLET 3-5	5,810.99	16.0	2.375	Circle	42.0	0.013	37.30	13.25	5,813.27	5,812.96
INLET 3-5	5,810.89	STMH 1-5	5,806.01	266.0	1.835	Circle	42.0	0.013	41.40	12.42	5,812.89	5,808.25
INLET 7-5	5,827.14	STMH 4-5	5,822.27	104.6	4.656	Circle	24.0	0.013	4.30	9.57	5,827.87	5,823.07
STMH 4-5	5,822.27	INLET 6-5	5,821.44	23.0	3.609	Circle	24.0	0.013	4.30	8.75	5,823.00	5,822.22
STMH 2-5A	5,812.17	STMH 2-5	5,811.47	50.0	1.400	Circle	36.0	0.013	20.60	9.39	5,813.63	5,813.44
STMH 2-5B	5,815.51	STMH 2-5A	5,812.17	241.0	1.386	Circle	30.0	0.013	18.10	9.13	5,816.95	5,813.67
STMH 2-4	5,820.42	STMH 1-4	5,818.85	60.0	2.609	Circle	36.0	0.013	24.20	12.30	5,822.00	5,819.89
STMH 1-4	5,818.85	FES 1-4	5,818.00	33.0	2.576	Circle	36.0	0.013	24.20	12.24	5,820.44	5,820.00
INLET 1-3	5,829.94	STMH 1-3	5,829.37	18.4	3.098	Circle	24.0	0.013	10.00	10.55	5,831.07	5,830.85
STMH 1-3	5,829.37	O-1	5,829.00	12.0	3.083	Circle	24.0	0.013	10.00	10.53	5,830.83	5,830.90
INLET 5-4A	5,829.26	STMH 5-4	5,828.83	43.0	1.000	Circle	18.0	0.013	1.10	3.85	5,829.65	5,829.16
STMH 2-5E	5,820.80	STMH 2-5D	5,820.12	44.0	1.545	Circle	24.0	0.013	8.60	7.86	5,821.85	5,821.44
STMH 2-5D	5,820.12	STMH 2-5C	5,819.49	45.0	1.400	Circle	24.0	0.013	12.10	8.31	5,821.37	5,820.88
STMH 2-5C	5,819.49	STMH 2-5B	5,815.51	289.0	1.377	Circle	30.0	0.013	15.60	8.75	5,820.82	5,816.99
INLET 4-5B	5,819.70	STMH 2-5C	5,819.52	18.0	1.000	Circle	18.0	0.013	3.50	5.35	5,820.87	5,820.87
INLET 5-5B	5,828.30	STMH 2-5D	5,820.22	293.0	2.758	Circle	18.0	0.013	3.50	7.71	5,829.01	5,821.44
INLET 4-5C	5,815.79	STMH 2-5B	5,815.61	18.0	1.000	Circle	18.0	0.013	2.50	4.88	5,816.99	5,816.98
INLET 6-5	5,821.14	STMH 3-5A	5,812.67	247.0	3.429	Circle	30.0	0.013	8.50	10.23	5,822.11	5,813.94
STMH 3-5A	5,812.67	STMH 2-5	5,811.37	48.0	2.708	Circle	30.0	0.013	13.30	10.69	5,813.90	5,813.34
INLET 6-5A	5,812.86	STMH 3-5A	5,812.67	19.0	1.000	Circle	18.0	0.013	2.70	4.98	5,813.93	5,813.93
INLET 6-5B	5,812.86	STMH 3-5A	5,812.67	19.0	1.000	Circle	18.0	0.013	2.10	4.64	5,813.92	5,813.93
STMH 4-9	5,813.94	STMH 1-11	5,814.80	172.3	-0.499	Circle	18.0	0.013	5.60	4.61	5,815.77	5,815.24
INL 2-9	5,792.34	FOREBAY B	5,790.35	32.3	6.169	Circle	30.0	0.013	19.26	15.95	5,793.83	5,791.21
STMH 3-9	5,808.00	INL 2-9	5,792.50	176.4	8.789	Circle	30.0	0.013	19.26	18.10	5,809.49	5,793.17
INL-20	5,826.54	STMH-19	5,825.91	82.4	0.765	Circle	18.0	0.013	2.17	4.25	5,827.10	5,826.41

FlexTable: Conduit Table

Start Node	Invert (Start) (ft)	Stop Node	Invert (Stop) (ft)	Length (User Defined) (ft)	Slope (Calculated) (%)	Section Type	Diameter (in)	Manning's n	Flow (cfs)	Velocity (ft/s)	Hydraulic Grade Line (In) (ft)	Hydraulic Grade Line (Out) (ft)
STMH-19	5,825.71	STMH-18	5,825.05	131.3	0.500	Circle	18.0	0.013	2.17	3.65	5,826.26	5,825.61
STMH-18	5,824.85	INL-17	5,824.14	142.2	0.500	Circle	18.0	0.013	2.17	3.65	5,825.41	5,824.73
INL-17	5,823.94	FUTURE STMH	5,819.36	179.3	2.555	Circle	18.0	0.013	4.27	7.94	5,824.73	5,819.88
INL-16A	5,820.65	FUTURE STMH	5,819.36	11.2	11.494	Circle	18.0	0.013	4.59	13.87	5,821.47	5,819.81
FUTURE STMH	5,818.66	STMH 4-9	5,816.72	86.4	2.243	Circle	24.0	0.013	8.86	9.08	5,819.72	5,817.42
MH-34	5,816.68	INL 2-10	5,817.68	19.2	-5.211	Circle	18.0	0.013	2.80	9.08	5,818.31	5,817.36
INL 2-10A	5,817.68	MH-34	5,816.68	19.2	5.208	Circle	18.0	0.013	2.00	8.23	5,818.21	5,817.36
STMH 4-9	5,816.23	MH-34	5,816.48	50.3	-0.497	Circle	18.0	0.013	4.80	4.46	5,817.36	5,817.07
STMH 4-9	5,813.75	STMH 3-9	5,808.10	395.0	1.430	Circle	30.0	0.013	19.26	9.39	5,815.24	5,809.19
STMH 1-11	5,814.80	INL 2-11	5,815.00	19.2	-1.042	Circle	18.0	0.013	3.00	5.20	5,815.70	5,815.77
STMH 1-11	5,814.80	INL 2-11A	5,815.00	19.2	-1.042	Circle	18.0	0.013	2.60	5.00	5,815.73	5,815.77

FlexTable: Conduit Table 100 YR STORM EVENT

Start Node	Invert (Start) (ft)	Stop Node	Invert (Stop) (ft)	Length (User Defined) (ft)	Slope (Calculated) (%)	Section Type	Diameter (in)	Manning's n	Flow (cfs)	Velocity (ft/s)	Hydraulic Grade Line (In) (ft)	Hydraulic Grade Line (Out) (ft)
STMH 6-4	5,834.91	INLET 6-4	5,832.53	120.0	1.98	Circle	36	0.013	47.81	13.34	5,837.16	5,834.11
INLET 6-4	5,832.33	STMH 5-4	5,827.71	278.0	1.66	Circle	36	0.013	51.31	12.70	5,834.66	5,829.38
FES 2-5	5,834.54	INLET 8-5	5,834.00	7.7	7.01	Circle	24	0.013	24.64	18.14	5,836.29	5,835.76
INLET 5-4	5,829.34	STMH 5-4	5,828.83	52.0	0.99	Circle	18	0.013	9.80	6.72	5,830.55	5,829.98
INLET 3-4	5,825.42	STMH 4-4	5,825.23	20.0	0.95	Circle	18	0.013	11.20	6.34	5,828.21	5,827.98
INLET 1-4	5,823.04	DIVERSION - STMH 2-4	5,821.92	65.0	1.72	Circle	18	0.013	7.70	4.36	5,825.66	5,825.31
INLET 4-4	5,825.42	STMH 4-4	5,825.23	20.0	0.95	Circle	18	0.013	2.40	1.36	5,827.99	5,827.98
INLET 2-6	5,814.55	INLET 1-6	5,814.15	80.0	0.50	Circle	18	0.013	8.10	4.58	5,816.12	5,815.65
INLET 2-3	5,836.69	INLET 1-3	5,831.04	94.0	6.01	Circle	24	0.013	9.00	12.99	5,837.76	5,832.27
FES 2-4	5,842.00	STMH 6-4	5,835.11	221.0	3.12	Circle	36	0.013	47.81	15.79	5,844.25	5,837.57
STMH 5-4	5,827.41	STMH 4-4	5,822.96	163.0	2.73	Circle	36	0.013	63.33	16.13	5,829.97	5,827.98
INLET 4-5	5,812.96	STMH 2-5A	5,812.27	19.0	3.63	Circle	18	0.013	8.90	5.04	5,815.78	5,815.64
INLET 5-5	5,813.90	STMH 2-5	5,811.47	49.0	4.96	Circle	18	0.013	9.10	5.15	5,815.90	5,815.53
STMH 4-4	5,822.16	STMH 3-4	5,821.56	79.0	0.76	Circle	36	0.013	76.93	10.88	5,827.98	5,826.93
STMH 3-4	5,821.46	DIVERSION - STMH 2-4	5,820.65	76.0	1.07	Circle	36	0.013	84.93	12.02	5,826.54	5,825.31
INLET 2-4	5,822.07	STMH 3-4	5,821.56	56.0	0.91	Circle	18	0.013	8.00	4.53	5,827.03	5,826.71
INLET 8-5	5,833.51	INLET 7-5	5,827.49	173.0	3.48	Circle	24	0.013	24.64	13.95	5,835.26	5,830.99
INLET 4-5A	5,821.14	STMH 2-5E	5,820.90	20.0	1.20	Circle	18	0.013	10.20	5.77	5,823.36	5,823.17
INLET 5-5A	5,821.14	STMH 2-5E	5,820.90	20.0	1.20	Circle	18	0.013	10.62	6.01	5,823.38	5,823.18
STMH 2-5	5,811.37	INLET 3-5	5,810.99	16.0	2.38	Circle	42	0.013	123.06	17.88	5,814.71	5,814.57
INLET 7-5	5,827.14	STMH 4-5	5,822.27	104.6	4.66	Circle	24	0.013	34.84	11.09	5,829.88	5,827.40
STMH 4-5	5,822.27	INLET 6-5	5,821.44	23.0	3.61	Circle	24	0.013	34.84	11.09	5,826.05	5,825.51
STMH 2-5A	5,812.17	STMH 2-5	5,811.47	50.0	1.40	Circle	36	0.013	48.02	6.79	5,815.56	5,815.30
STMH 2-5B	5,815.51	STMH 2-5A	5,812.17	241.0	1.39	Circle	30	0.013	39.12	10.95	5,817.62	5,815.66
DIVERSION - STMH 2-4	5,820.42	STMH 1-4	5,818.85	72.0	2.17	Circle	36	0.013	69.03	15.06	5,823.06	5,820.88
STMH 1-4	5,818.23	FES 1-4	5,818.00	28.0	0.82	Circle	36	0.013	69.03	9.77	5,821.05	5,820.64
INLET 1-3	5,829.94	STMH 1-3	5,829.37	18.4	3.10	Circle	24	0.013	22.50	13.06	5,831.63	5,831.16
STMH 1-3	5,829.37	O-1	5,829.00	12.0	3.08	Circle	24	0.013	22.50	13.04	5,831.06	5,830.90
INLET 5-4A	5,829.26	STMH 5-4	5,828.83	43.0	1.00	Circle	18	0.013	2.22	4.71	5,829.92	5,829.97
STMH 2-5E	5,820.80	STMH 2-5D	5,820.12	44.0	1.55	Circle	24	0.013	20.82	6.63	5,822.95	5,822.58
STMH 2-5D	5,820.12	STMH 2-5C	5,819.49	45.0	1.40	Circle	24	0.013	28.32	9.01	5,822.34	5,821.64
STMH 2-5C	5,819.49	STMH 2-5B	5,815.51	289.0	1.38	Circle	30	0.013	35.22	10.71	5,821.51	5,817.73
INLET 4-5B	5,819.70	STMH 2-5C	5,819.52	18.0	1.00	Circle	18	0.013	6.90	3.90	5,821.69	5,821.62
INLET 5-5B	5,828.30	STMH 2-5D	5,820.22	293.0	2.76	Circle	18	0.013	7.50	9.49	5,829.36	5,822.56
INLET 4-5C	5,815.79	STMH 2-5B	5,815.61	18.0	1.00	Circle	18	0.013	3.90	2.21	5,817.71	5,817.68
INLET 6-5	5,821.14	STMH 3-5A	5,812.67	247.0	3.43	Circle	30	0.013	54.44	11.09	5,824.34	5,819.99
STMH 3-5A	5,812.67	STMH 2-5	5,811.37	48.0	2.71	Circle	30	0.013	65.94	13.43	5,816.29	5,815.04
INLET 6-5A	5,812.86	STMH 3-5A	5,812.67	19.0	1.00	Circle	18	0.013	6.20	3.51	5,820.05	5,819.99
INLET 6-5B	5,812.86	STMH 3-5A	5,812.67	19.0	1.00	Circle	18	0.013	5.30	3.00	5,820.04	5,819.99
DIVERSION - STMH 2-4	5,820.42	STMH 1-12	5,820.26	32.0	0.49	Circle	30	0.013	23.60	0.00	5,823.64	5,823.53
STMH 1-12	5,820.16	STMH 2-12	5,819.90	52.0	0.50	Circle	30	0.013	23.60	6.58	5,822.55	5,822.40
STMH 2-12	5,819.80	STMH 3-12	5,818.95	168.0	0.51	Circle	30	0.013	23.60	6.62	5,821.51	5,820.65
STMH 3-12	5,818.85	STMH 4-12	5,817.87	196.0	0.50	Circle	30	0.013	23.60	6.58	5,820.56	5,819.52
STMH 4-12	5,817.77	STMH 5-12	5,816.66	202.0	0.55	Circle	30	0.013	23.60	6.84	5,819.42	5,818.41
STMH 5-12	5,816.66	STMH 6-12	5,808.94	286.0	2.70	Circle	30	0.013	23.60	12.51	5,818.31	5,813.17
STMH 6-12	5,812.33	STMH 7-12	5,812.68	71.0	-0.49	Circle	18	0.013	5.80	4.62	5,813.68	5,813.26

FlexTable: Conduit Table

Start Node	Invert (Start) (ft)	Stop Node	Invert (Stop) (ft)	Length (User Defined) (ft)	Slope (Calculated) (%)	Section Type	Diameter (in)	Manning's n	Flow (cfs)	Velocity (ft/s)	Hydraulic Grade Line (In) (ft)	Hydraulic Grade Line (Out) (ft)
INLET 1-6	5,814.05	DIVERSION - STMH 8-12	5,813.06	16.0	6.19	Circle	24	0.013	15.40	15.27	5,815.46	5,813.98
STMH 6-12	5,808.84	STMH 9-12	5,807.59	249.0	0.50	Circle	42	0.013	29.40	3.06	5,812.98	5,812.77
INLET 2-5	5,808.45	STMH 10-12	5,806.11	24.0	9.75	Circle	24	0.013	23.50	7.48	5,812.90	5,812.64
STMH 10-12	5,806.11	INLET 1-5	5,808.34	66.0	-3.38	Circle	24	0.013	15.10	4.81	5,812.94	5,812.64
STMH 9-12	5,807.49	STMH 10-12	5,806.11	275.0	0.50	Circle	48	0.013	29.40	2.34	5,812.76	5,812.64
STMH 10-12	5,806.01	STMH 11-12	5,805.50	103.0	0.50	Circle	48	0.013	68.00	5.41	5,812.62	5,812.39
STMH 13-12	5,792.21	STMH 14-12	5,790.94	255.0	0.50	Circle	60	0.013	185.43	9.44	5,798.76	5,797.47
STMH 14-12	5,790.84	FES 1-5	5,790.21	126.0	0.50	Circle	60	0.013	185.43	9.44	5,797.29	5,796.65
STMH 12-12	5,795.80	STMH 13-12	5,792.31	233.0	1.50	Circle	60	0.013	185.43	16.85	5,799.70	5,798.94
DIVERSION - STMH 8-12	5,812.96	STMH 7-12	5,812.78	35.0	0.51	Circle	18	0.013	5.80	0.00	5,814.67	5,814.56
STMH 11-12	5,805.38	STMH 11A-12	5,802.37	117.0	2.57	Circle	60	0.013	204.96	21.17	5,809.46	5,806.46
STMH 11A-12	5,802.27	STMH 12-12	5,795.90	318.0	2.00	Circle	60	0.013	204.96	19.27	5,806.35	5,802.31
DIVERSION - STMH 8-12	5,812.96	STMH-8A	5,806.30	116.0	5.74	Circle	24	0.013	9.60	13.01	5,814.07	5,808.33
STMH-8A	5,806.20	FES1-6	5,806.00	40.0	0.50	Circle	24	0.013	9.60	3.06	5,808.33	5,808.26
INLET 3-5	5,810.89	MH-1-5A	5,808.93	105.5	1.86	Circle	48	0.013	136.96	16.85	5,814.37	5,813.25
MH-1-5A	5,808.93	STMH 11-12	5,805.47	95.1	3.64	Circle	48	0.013	136.96	10.90	5,813.25	5,812.39
OUTLET STRUCTURE	5,787.19	O-2	5,785.30	127.9	1.48	Circle	36	0.013	59.30	12.52	5,789.68	5,787.26
CB-12	5,792.34	FOREBAY B	5,790.35	32.3	6.16	Circle	30	0.013	33.00	6.72	5,796.88	5,796.67
STMH 4-9	5,813.75	STMH 3-9	5,808.10	395.0	1.43	Circle	30	0.013	51.90	11.29	5,816.07	5,810.31
STMH 4-9	5,816.23	STMH 1-10	5,816.48	50.3	-0.50	Circle	18	0.013	11.30	6.39	5,818.21	5,817.51
INL 2-10A	5,817.68	STMH 1-10	5,816.68	19.2	5.21	Circle	18	0.013	5.20	10.84	5,818.56	5,818.21
STMH 1-10	5,816.68	INL 2-10	5,817.68	19.2	-5.21	Circle	18	0.013	6.10	11.33	5,818.63	5,818.21
STMH-16	5,818.66	STMH 4-9	5,814.25	113.7	3.88	Circle	24	0.013	25.80	14.70	5,820.44	5,816.07
INL-16A	5,820.65	STMH-16	5,819.36	11.2	11.49	Circle	18	0.013	12.12	18.23	5,821.97	5,820.18
INL-17	5,823.94	STMH-16	5,819.36	179.3	2.55	Circle	18	0.013	13.68	10.59	5,825.31	5,820.39
STMH-18	5,824.85	INL-17	5,824.14	142.2	0.50	Circle	18	0.013	7.42	4.79	5,826.08	5,825.31
STMH-19	5,825.71	STMH-18	5,825.05	131.3	0.50	Circle	18	0.013	7.42	4.79	5,826.93	5,826.11
INL-20	5,826.54	STMH-19	5,825.91	82.4	0.76	Circle	18	0.013	7.42	5.78	5,827.60	5,826.93
STMH 3-9	5,808.00	INL 2-9	5,792.50	176.4	8.79	Circle	30	0.013	51.90	23.79	5,810.32	5,793.65
INL 2-9	5,792.34	FOREBAY B	5,790.35	32.3	6.17	Circle	30	0.013	51.90	20.84	5,794.66	5,791.94
STMH 4-9	5,813.94	STMH 1-11	5,814.80	172.3	-0.50	Circle	18	0.013	14.80	8.38	5,819.49	5,816.07
STMH 1-11	5,814.80	INL 2-11A	5,815.00	19.2	-1.04	Circle	18	0.013	7.00	3.96	5,819.58	5,819.49
STMH 1-11	5,814.80	INL 2-11	5,815.00	19.2	-1.04	Circle	18	0.013	7.80	4.41	5,819.60	5,819.49

Temporary Swale East of Residential Site - Upper

Project Description

Friction Method	Manning Formula
Solve For	Normal Depth

Input Data

Roughness Coefficient	0.035	
Channel Slope	0.01000	ft/ft
Left Side Slope	0.20	ft/ft (H:V)
Right Side Slope	0.20	ft/ft (H:V)
Bottom Width	4.00	ft
Discharge	9.80	ft ³ /s

Results

Normal Depth	0.79	ft
Flow Area	3.29	ft ²
Wetted Perimeter	5.62	ft
Hydraulic Radius	0.59	ft
Top Width	4.32	ft
Critical Depth	0.57	ft
Critical Slope	0.02837	ft/ft
Velocity	2.98	ft/s
Velocity Head	0.14	ft
Specific Energy	0.93	ft
Froude Number	0.60	
Flow Type	Subcritical	

GVF Input Data

Downstream Depth	0.00	ft
Length	0.00	ft
Number Of Steps	0	

GVF Output Data

Upstream Depth	0.00	ft
Profile Description		
Profile Headloss	0.00	ft
Downstream Velocity	Infinity	ft/s
Upstream Velocity	Infinity	ft/s
Normal Depth	0.79	ft
Critical Depth	0.57	ft
Channel Slope	0.01000	ft/ft

Temp Swale East of Street E - Top

GVF Output Data

Critical Slope 0.02837 ft/ft

Temporary Swale East of Residential Site - Lower

Project Description

Friction Method	Manning Formula
Solve For	Normal Depth

Input Data

Roughness Coefficient	0.050	
Channel Slope	0.10000	ft/ft
Left Side Slope	0.20	ft/ft (H:V)
Right Side Slope	0.20	ft/ft (H:V)
Bottom Width	4.00	ft
Discharge	9.80	ft ³ /s

Results

Normal Depth	0.48	ft
Flow Area	1.95	ft ²
Wetted Perimeter	4.97	ft
Hydraulic Radius	0.39	ft
Top Width	4.19	ft
Critical Depth	0.57	ft
Critical Slope	0.05791	ft/ft
Velocity	5.03	ft/s
Velocity Head	0.39	ft
Specific Energy	0.87	ft
Froude Number	1.30	
Flow Type	Supercritical	

GVF Input Data

Downstream Depth	0.00	ft
Length	0.00	ft
Number Of Steps	0	

GVF Output Data

Upstream Depth	0.00	ft
Profile Description		
Profile Headloss	0.00	ft
Downstream Velocity	Infinity	ft/s
Upstream Velocity	Infinity	ft/s
Normal Depth	0.48	ft
Critical Depth	0.57	ft
Channel Slope	0.10000	ft/ft

Temp Swale East of Street E - Bottom

GVF Output Data

Critical Slope 0.05791 ft/ft

TEMPORARY SWALE (EAST OF RESIDENTIAL SITE)

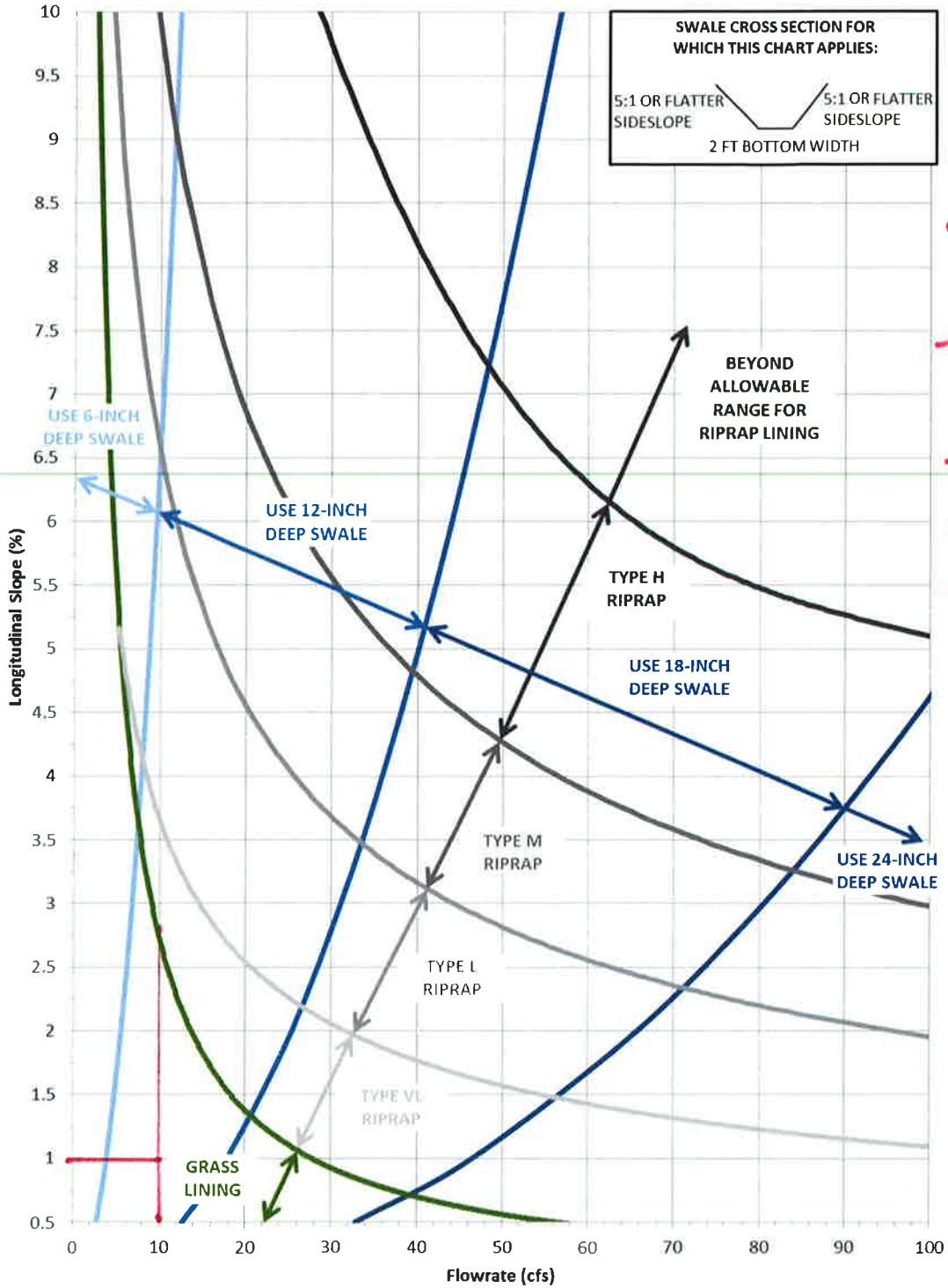

Upper
 $Q = 9.8 \text{ cfs}$
 $s = 1\%$
 -1' Deep to Match Lower
 -Grass lined
 -2' Bottom
 -5:1 Sides

Figure 8-22. Swale stability chart; 2- to 4-foot bottom width and side slopes between 5:1 and 10:1
 (Note: Riprap classifications refer to gradation for riprap used in soil riprap or void-filled riprap. See Figure 8-34 for gradations.) (Source: Muller Engineering Company)

TEMPORARY SWALE (EAST OF RESIDENTIAL SITE)

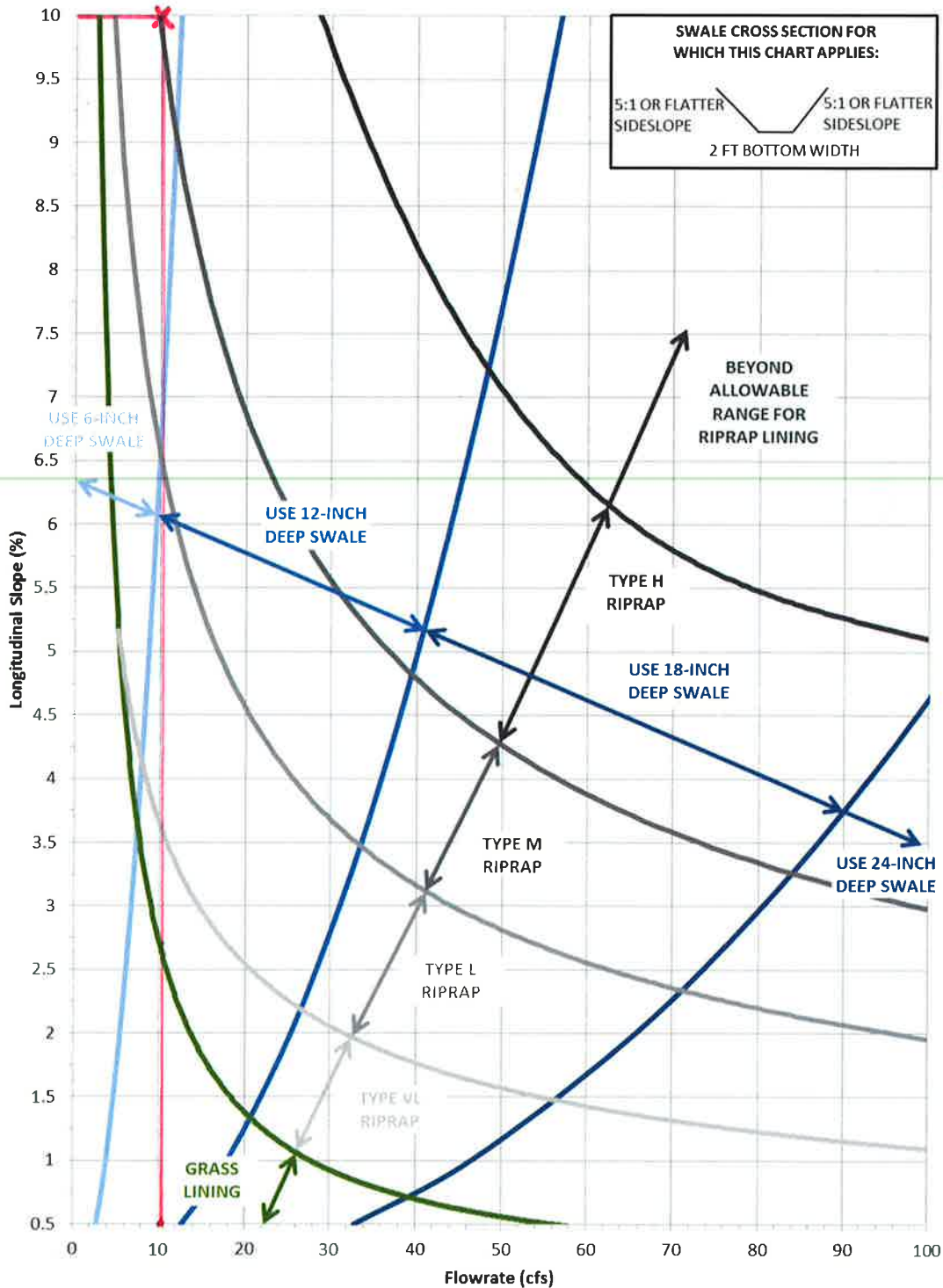
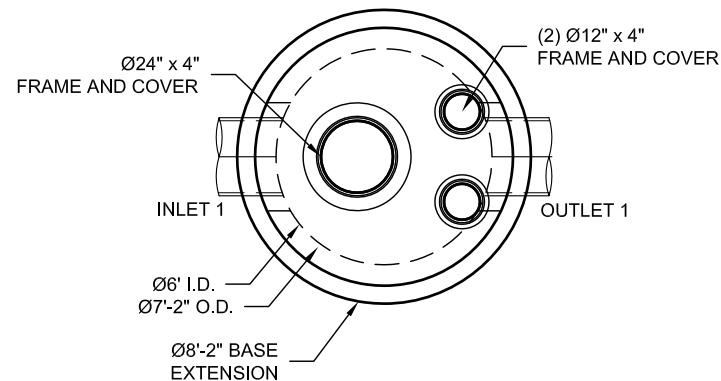
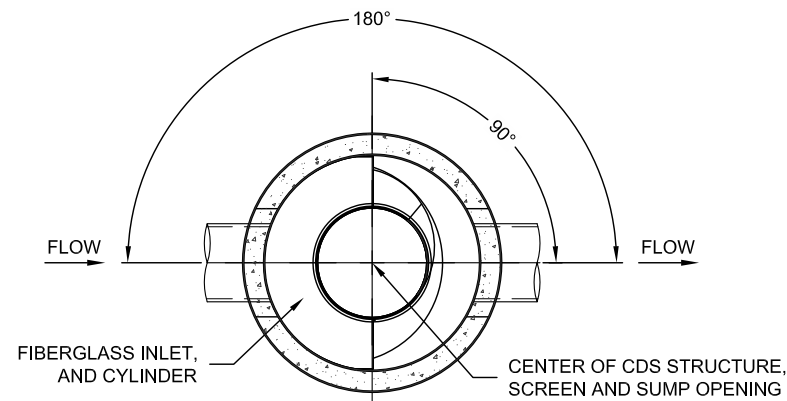

Figure 8-22. Swale stability chart; 2- to 4-foot bottom width and side slopes between 5:1 and 10:1
 (Note: Riprap classifications refer to gradation for riprap used in soil riprap or void-filled riprap. See Figure 8-34 for gradations.) (Source: Muller Engineering Company)

FOR REFERENCE ONLY. TO BE CONSTRUCTED AS PART OF FILING 1.



PLAN VIEW



SECTION A-A

● INTERNAL COMPONENTS TO BE INSTALLED BY CONTECH ON SITE

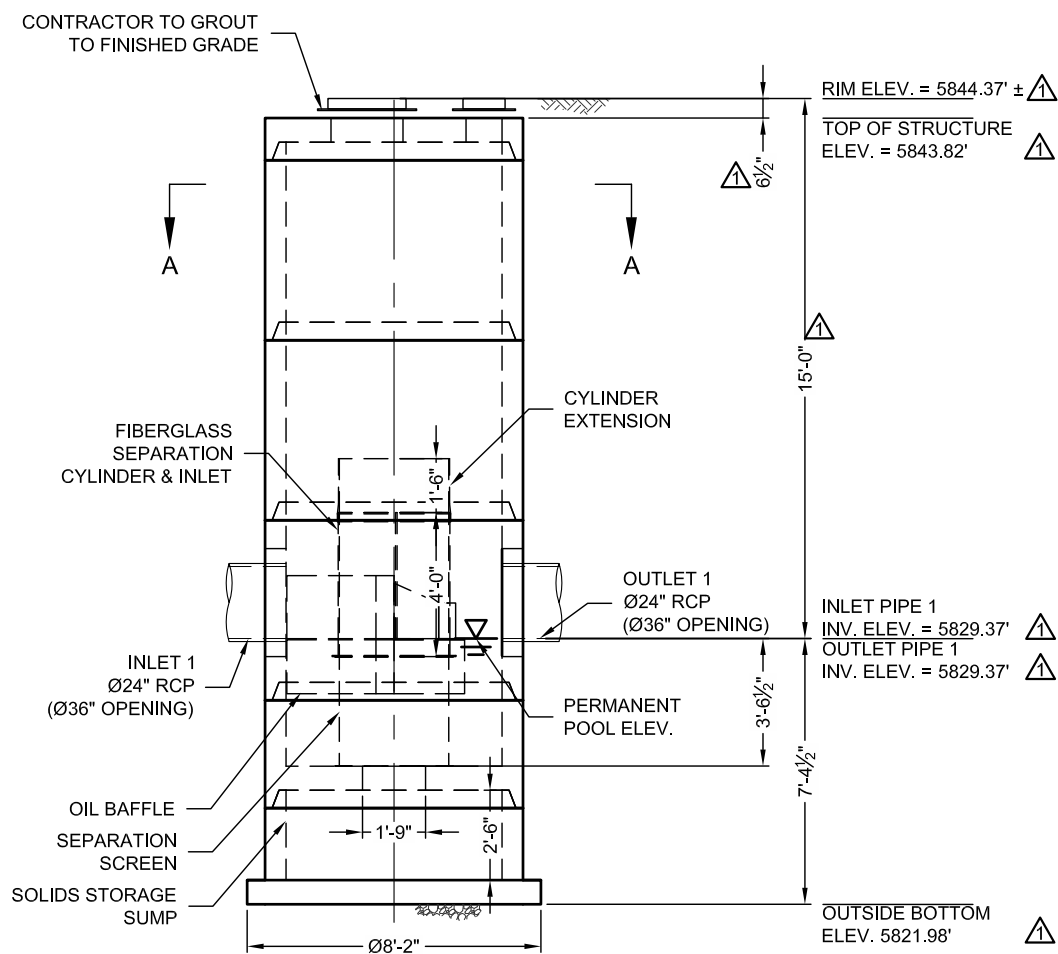

ELEVATION VIEW

MATERIAL LIST (PROVIDED BY CONTECH)

COUNT	DESCRIPTION	INSTALLED BY
1	FIBERGLASS INLET AND CYLINDER	CONTECH
1	2400 micron, 3' O.D. x 3.04' SEP. SCREEN	CONTECH
1	CYLINDER EXTENSION	CONTRACTOR
1	SEALANT FOR JOINTS (BY PRECASTER)	CONTRACTOR
1	Ø24" x 4" FRAME & COVER, E.J.#41600389, OR EQUIV.	CONTRACTOR
2	Ø12" x 4" FRAME & COVER, E.J.#41610201, OR EQUIV.	CONTRACTOR

SITE DESIGN DATA

WATER QUALITY FLOW RATE	0 CFS
PEAK FLOW RATE	29.2 CFS
RETURN PERIOD OF PEAK FLOW	100 YRS

GENERAL NOTES

- CONTECH TO PROVIDE ALL MATERIALS UNLESS NOTED OTHERWISE.
- FOR FABRICATION DRAWINGS WITH DETAILED STRUCTURE DIMENSIONS AND WEIGHT, PLEASE CONTACT YOUR CONTECH ENGINEERED SOLUTIONS LLC REPRESENTATIVE. www.ContechES.com
- CDS WATER QUALITY STRUCTURE SHALL BE IN ACCORDANCE WITH ALL DESIGN DATA AND INFORMATION CONTAINED IN THIS DRAWING. CONTRACTOR TO CONFIRM STRUCTURE MEETS REQUIREMENTS OF PROJECT.
- STRUCTURE SHALL MEET AASHTO HS-20 LOAD RATING, ASSUMING EARTH COVER OF 0' - 2', AND GROUNDWATER ELEVATION AT, OR BELOW, THE OUTLET PIPE INVERT ELEVATION. ENGINEER OF RECORD TO CONFIRM ACTUAL GROUNDWATER ELEVATION. CASTINGS SHALL MEET AASHTO M306 AND BE CAST WITH THE CONTECH LOGO.
- IF REQUIRED, PVC HYDRAULIC SHEAR PLATE IS PLACED ON SHELF AT BOTTOM OF SCREEN CYLINDER. REMOVE AND REPLACE AS NECESSARY DURING MAINTENANCE CLEANING.
- CDS STRUCTURE SHALL BE PRECAST CONCRETE CONFORMING TO ASTM C-478 AND AASHTO LOAD FACTOR DESIGN METHOD.

INSTALLATION NOTES

- ANY SUB-BASE, BACKFILL DEPTH, AND/OR ANTI-FLOTATION PROVISIONS ARE SITE-SPECIFIC DESIGN CONSIDERATIONS AND SHALL BE SPECIFIED BY ENGINEER OF RECORD.
- CONTRACTOR TO PROVIDE EQUIPMENT WITH SUFFICIENT LIFTING AND REACH CAPACITY TO LIFT AND SET THE CDS MANHOLE STRUCTURE.
- CONTRACTOR TO INSTALL JOINT SEALANT BETWEEN ALL STRUCTURE SECTIONS AND ASSEMBLE STRUCTURE.
- CONTRACTOR TO PROVIDE, INSTALL, AND GROUT INLET AND OUTLET PIPE(S). MATCH PIPE INVERTS WITH ELEVATIONS SHOWN. ALL PIPE CENTERLINES TO MATCH PIPE OPENING CENTERLINES.
- CONTRACTOR TO TAKE APPROPRIATE MEASURES TO ASSURE UNIT IS WATER TIGHT, HOLDING WATER TO FLOWLINE INVERT MINIMUM. IT IS SUGGESTED THAT ALL JOINTS BELOW PIPE INVERTS ARE GROUTED.

▲ **STRUCTURE WEIGHT**
 APPROXIMATE HEAVIEST PICK = 10000 LBS.
 STRUCTURE IS DELIVERED IN 6 PIECES

MAX FOOTPRINT = Ø8'-2"

CONTECH
CONTRACT
 DRAWING

The design and information shown on this drawing is the property of CONTECH ENGINEERED SOLUTIONS LLC. It is to be used only for the project and location specified. No part of this drawing, nor any part thereof, may be used, reproduced, or transmitted in any form or by any means, electronic, mechanical, photocopying, recording, or by any information storage and retrieval system, without the prior written consent of CONTECH. Failure to comply is done at the user's own risk and CONTECH expressly disclaims any liability or responsibility for such use. If discrepancies between the supplied information upon which the drawing is based and actual field conditions are encountered as the work progresses, the user is encouraged to immediately contact CONTECH for re-evaluation of the design. CONTECH immediately for re-evaluation of the design. CONTECH accepts no liability for designs based on missing, incomplete or inaccurate information supplied by others.

MARK	DATE	REVISION DESCRIPTION	BY
1	7/28/16	IN/OUTLET & RIM ELEVATIONS	KJW

CDS3030-6-C - 542946-10
COMPARK SOUTH
PARKER, CO
 for SYSTEM: STMH 1-3

CONTECH
 ENGINEERED SOLUTIONS LLC
www.ContechES.com
 2201 W. Royal Lane, Suite 200, Irving, TX 75083
 972-508-2000 972-508-2088 FAX

CDS
 THE PRODUCT MAY BE PROTECTED BY ONE OR MORE OF THE FOLLOWING PATENTS OR OTHER PATENT RIGHTS.

DATE:	07/15/16	SCALE:	3/16" = 1'-0"
DESIGNED:	JHR	DRAWN:	KJW
CHECKED:	XXX	APPROVED:	----
PROJECT No.:	542946	SEQUENCE No.:	10
SHEET:	1	OF	1

LPICO
 LAYOUT 1A
 3030-6-FGIS
 1026 / FI72886

FOR REFERENCE ONLY. TO BE CONSTRUCTED AS PART OF FILING 1.

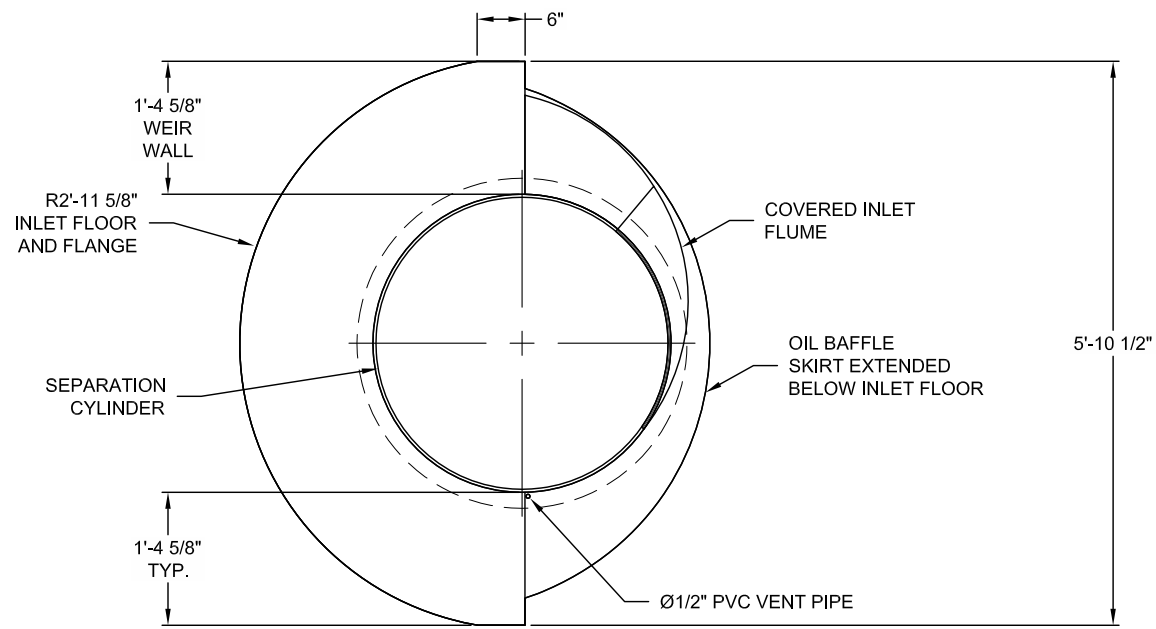

PLAN VIEW

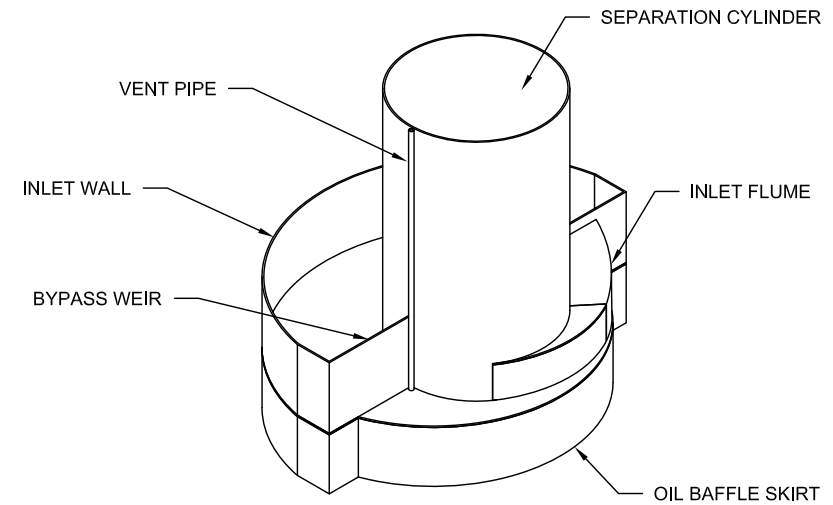

ASSEMBLY TOP VIEW
N.T.S.

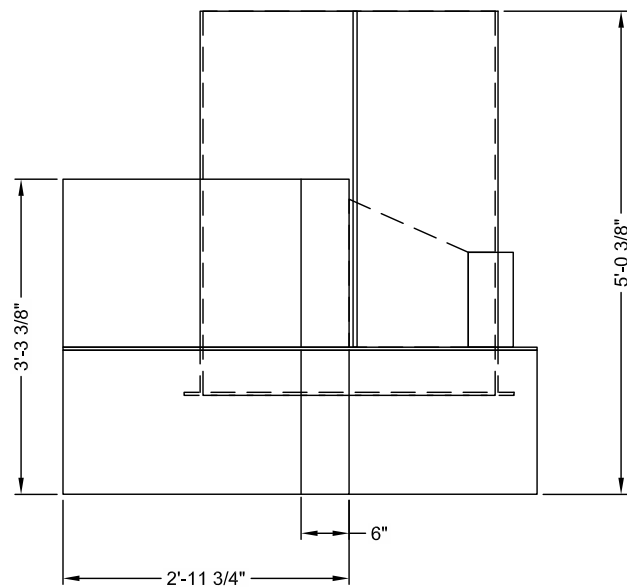

ELEVATION VIEW

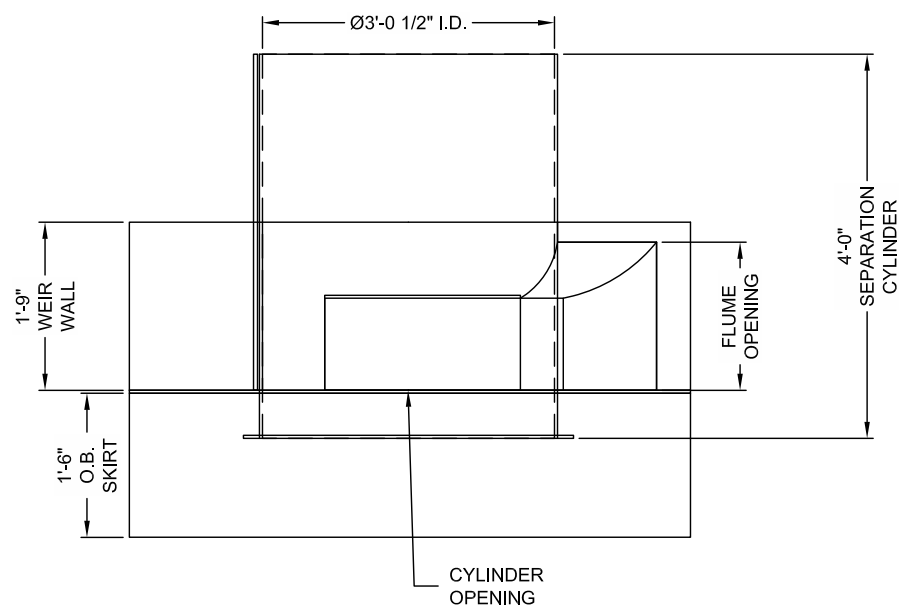

SIDE VIEW

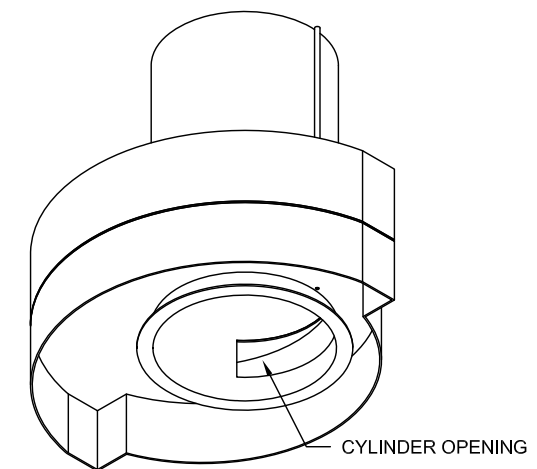

ASSEMBLY BOTTOM VIEW
N.T.S.

CONTECH
FABRICATION
DRAWING

The design and information shown on this drawing is the property of CONTECH Construction Products, Inc. or one of its affiliated companies ("CONTECH"). Neither this drawing, nor any part thereof, may be used, reproduced, or transmitted in any form or by any means, electronic or mechanical, including photocopying, recording, or by any information storage and retrieval system, without the prior written consent of CONTECH. Failure to comply is done at the user's own risk and CONTECH expressly disclaims any liability or responsibility for such use. If discrepancies between the supplied information upon which the drawing is based and actual field conditions are encountered as the work progresses, the user is encouraged to immediately notify CONTECH. CONTECH immediately for re-evaluation of the design. CONTECH accepts no liability for designs based on missing, incomplete or inaccurate information supplied by others.

MARK	DATE	REVISION DESCRIPTION	BY

CDS3030-6-C - 542946-10
COMPARK SOUTH
PARKER, CO
for SYSTEM: STMH 1-3

CONTECH
ENGINEERED SOLUTIONS LLC
www.contechES.com
2201 W. Royal Lane, Suite 200, Irving, TX 75063
972-500-2000 972-500-2089 FAX

CPS
THE PRODUCT MAY BE PROTECTED BY ONE OR MORE OF THE FOLLOWING PATENTS OR OTHER PATENT RIGHTS:

DATE: 07/15/16	SCALE: 1/2" = 1'-0"
DESIGNED: JHR	DRAWN: KJW
CHECKED: XXX	APPROVED: ----
PROJECT No.: 542946	SEQUENCE No.: 10

FOR REFERENCE ONLY. TO BE CONSTRUCTED AS PART OF FILING 1.

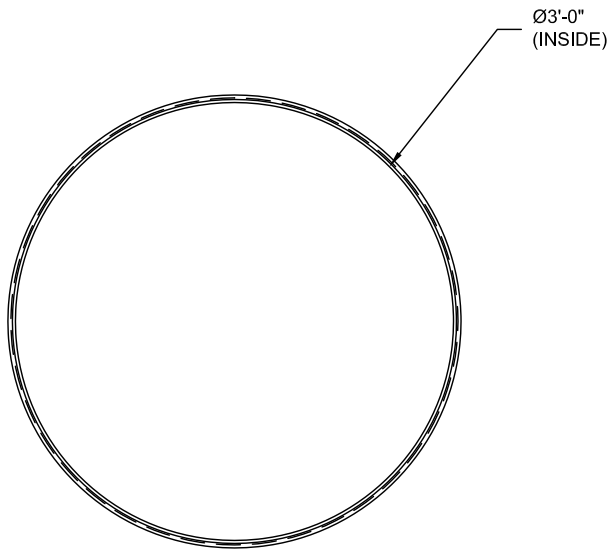

PLAN VIEW

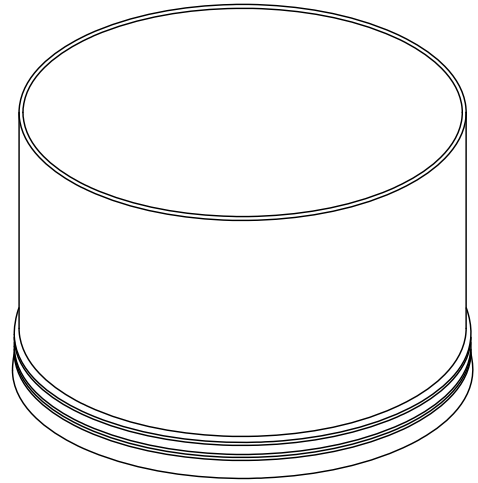

ISOMETRIC VIEW

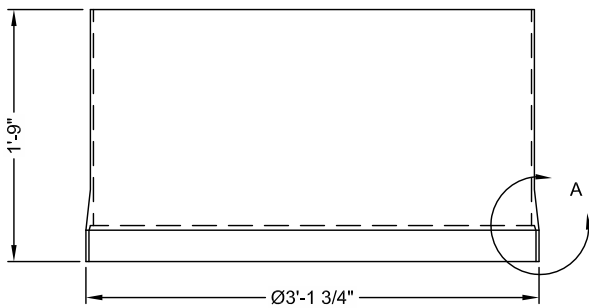

ELEVATION VIEW

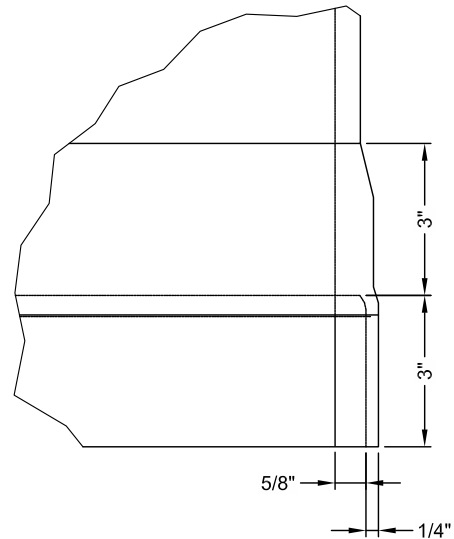

DETAIL A
SCALE 3/16



THIS PRODUCT MAY BE PROTECTED BY ONE OR MORE OF THE FOLLOWING U.S. PATENTS: 5,768,848; 6,641,720; 6,511,995; 6,581,783; RELATED FOREIGN PATENTS, OR OTHER PATENTS PENDING.

CONTECH
FABRICATION
DRAWING

CONTECH
ENGINEERED SOLUTIONS LLC
www.ContechES.com

2201 W. Royal Lane, Suite 260, Irving, TX 75063
972-590-2000 972-590-2039 FAX

CDS3030-6-C - 542946-10, CYLINDER EXTENSION DETAILS
COMPARK SOUTH
PARKER, CO
for SYSTEM: WQ UNIT #1

DATE:07/15/16	SCALE: 3/4" = 1'-0"	PROJECT No.: 542946	SEQ. No.: 10	DRAWN: KJW	CHECKED: XXX
---------------	---------------------	---------------------	--------------	------------	--------------

I:\MERLIN\PROJECT\ACTIVE\542946\542946-10-CDS\DRAWINGS\PRE-542946-10-CDS3030-6-C CONFAB.DWG 7/15/2016 10:19 AM

I:\COMMON\CAD\TREATMENT\22_CDS\44 FABRICATION\SCREENS (DERBY)\CDS\DWG\CDS SCREEN-FAB.DWG 7/21/2014 2:14 PM

FOR REFERENCE ONLY. TO BE CONSTRUCTED AS PART OF FILING 1.

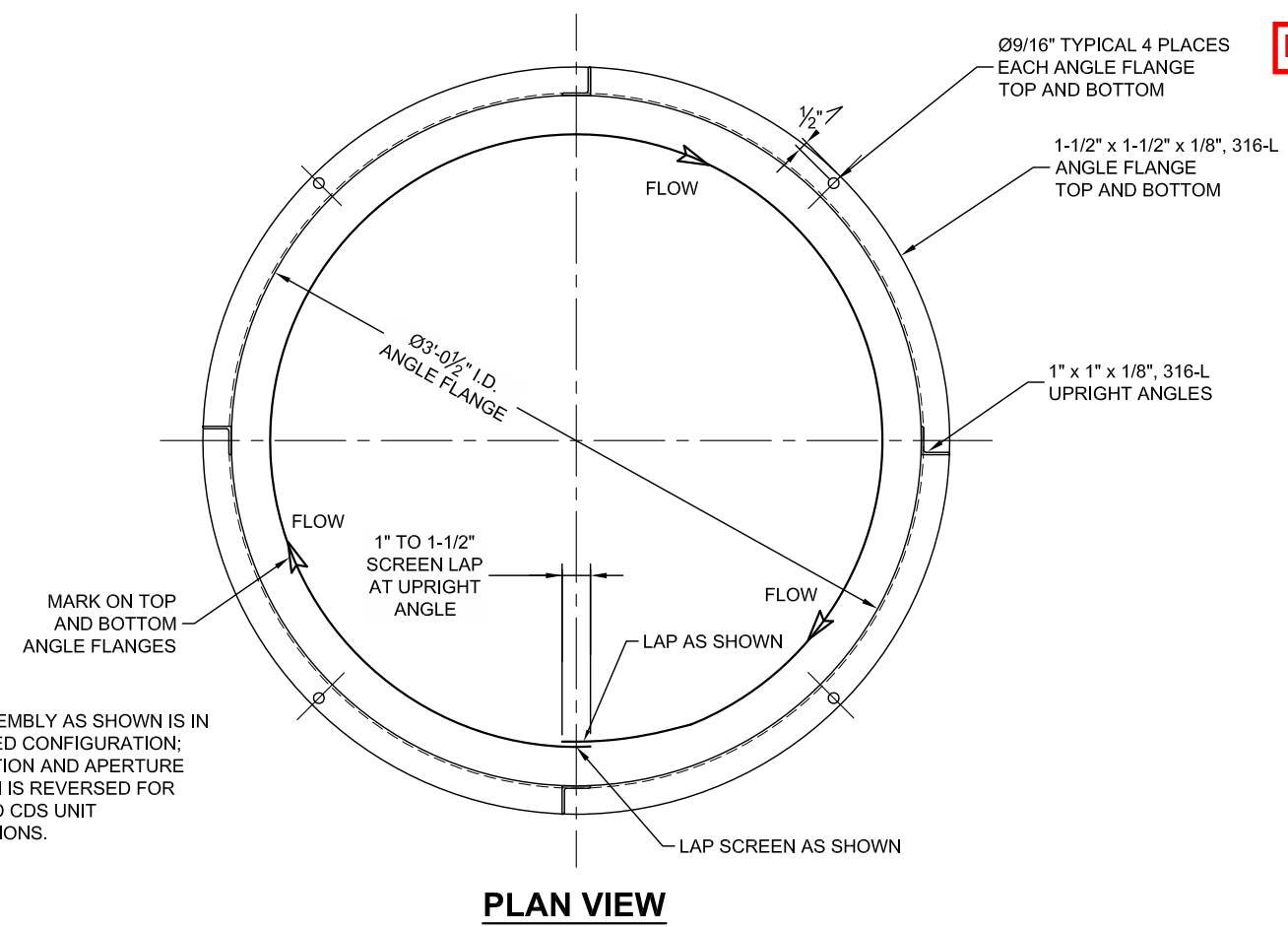

NOTE:
SCREEN ASSEMBLY AS SHOWN IS IN
RIGHT-HANDED CONFIGURATION;
FLOW DIRECTION AND APERTURE
ORIENTATION IS REVERSED FOR
LEFT-HANDED CDS UNIT
CONFIGURATIONS.

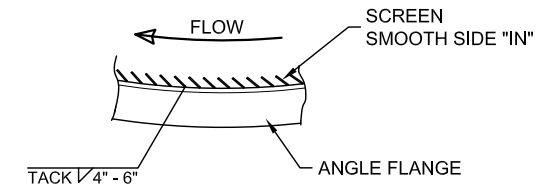

**SCREEN DETAIL
TOP VIEW**

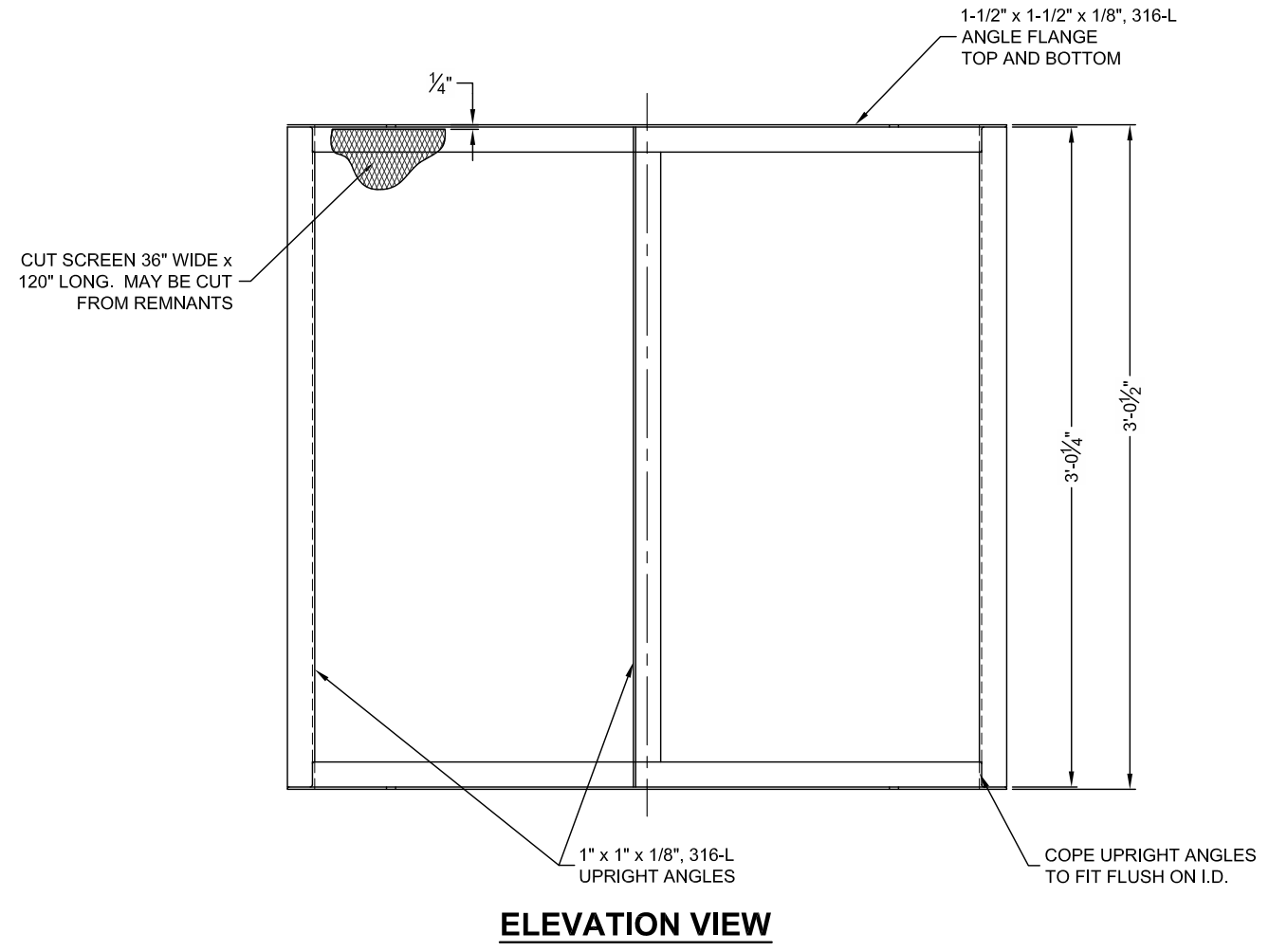

GENERAL NOTES:

1. ALL MATERIAL IS 316-L STAINLESS
2. SCREEN SHALL BE STAINLESS STEEL EXPANDED METAL CONFORMING TO ASTM 1267-01.
3. SCREEN APERTURE SIZE SHALL BE EITHER 4700 MICRON OR 2400 MICRON PER PROJECT ORDER.
4. TOP AND BOTTOM FLANGES MUST BE ROUND, FLAT, PARALLEL AND PLUM.
5. UPRIGHT ANGLES MUST BE PLUM AND SQUARE
6. STRAIGHTEN TOP AND BOTTOM FLANGES PRIOR TO ASSEMBLY OF FRAME.
7. FLATTEN ENDS OF SCREEN TO TOP AND BOTTOM ANGLE FLANGES PRIOR TO WELDING.
8. SCREEN IS TACK WELDED TO FRAME @ 4" CENTERS WITH SMOOTH SIDE ON INSIDE.
9. WIPE ANGLE FLANGES CLEAN AND PAINT:
 - CLOCKWISE END "GREEN" (RIGHT HAND FLOW).
 - COUNTER-CLOCKWISE END "RED" (LEFT HANDED FLOW).
10. FLANGE PAINTED GREEN ON TOP FOR RIGHT-HANDED CONFIGURATION.
11. FLANGE PAINTED RED ON TOP FOR LEFT-HANDED CONFIGURATION.
12. FABRICATOR TO SUPPLY THE FOLLOWING STAINLESS STEEL HARDWARE. SIZE AND QUANTITY OF ANCHORS AS INDICATED ON PROJECT ORDER.
 - FOR EACH 3/8" ANCHOR REQUIRED:
 - (1) 3/8" X 2-3/4" ANCHOR
 - (1) 3/8" NUT
 - (1) 3/8" LOCKWASHER
 - (1) 3/8" FLAT WASHER
 - FOR EACH 1/2" BOLT REQUIRED:
 - (1) 1/2" X 1-1/2" BOLT
 - (1) 1/2" NUT
 - (1) 1/2" LOCKWASHER
 - (2) 1/2" FLAT WASHERS

CDS3030
SCREEN ASSEMBLY DETAILS

CONTECH
ENGINEERED SOLUTIONS LLC
www.conteches.com
200 Enterprise Drive, Scarborough, ME 04074
877-507-8676 207-885-8830 207-885-8825 FAX

THIS PRODUCT HAS BEEN PROTECTED BY ONE OR MORE OF THE
FOLLOWING PATENTS: U.S. PATENT NO. 7,812,812; U.S. PATENT NO. 7,812,813; U.S. PATENT NO. 7,812,814; U.S. PATENT NO. 7,812,815; U.S. PATENT NO. 7,812,816; U.S. PATENT NO. 7,812,817; U.S. PATENT NO. 7,812,818; U.S. PATENT NO. 7,812,819; U.S. PATENT NO. 7,812,820; U.S. PATENT NO. 7,812,821; U.S. PATENT NO. 7,812,822; U.S. PATENT NO. 7,812,823; U.S. PATENT NO. 7,812,824; U.S. PATENT NO. 7,812,825; U.S. PATENT NO. 7,812,826; U.S. PATENT NO. 7,812,827; U.S. PATENT NO. 7,812,828; U.S. PATENT NO. 7,812,829; U.S. PATENT NO. 7,812,830; U.S. PATENT NO. 7,812,831; U.S. PATENT NO. 7,812,832; U.S. PATENT NO. 7,812,833; U.S. PATENT NO. 7,812,834; U.S. PATENT NO. 7,812,835; U.S. PATENT NO. 7,812,836; U.S. PATENT NO. 7,812,837; U.S. PATENT NO. 7,812,838; U.S. PATENT NO. 7,812,839; U.S. PATENT NO. 7,812,840; U.S. PATENT NO. 7,812,841; U.S. PATENT NO. 7,812,842; U.S. PATENT NO. 7,812,843; U.S. PATENT NO. 7,812,844; U.S. PATENT NO. 7,812,845; U.S. PATENT NO. 7,812,846; U.S. PATENT NO. 7,812,847; U.S. PATENT NO. 7,812,848; U.S. PATENT NO. 7,812,849; U.S. PATENT NO. 7,812,850; U.S. PATENT NO. 7,812,851; U.S. PATENT NO. 7,812,852; U.S. PATENT NO. 7,812,853; U.S. PATENT NO. 7,812,854; U.S. PATENT NO. 7,812,855; U.S. PATENT NO. 7,812,856; U.S. PATENT NO. 7,812,857; U.S. PATENT NO. 7,812,858; U.S. PATENT NO. 7,812,859; U.S. PATENT NO. 7,812,860; U.S. PATENT NO. 7,812,861; U.S. PATENT NO. 7,812,862; U.S. PATENT NO. 7,812,863; U.S. PATENT NO. 7,812,864; U.S. PATENT NO. 7,812,865; U.S. PATENT NO. 7,812,866; U.S. PATENT NO. 7,812,867; U.S. PATENT NO. 7,812,868; U.S. PATENT NO. 7,812,869; U.S. PATENT NO. 7,812,870; U.S. PATENT NO. 7,812,871; U.S. PATENT NO. 7,812,872; U.S. PATENT NO. 7,812,873; U.S. PATENT NO. 7,812,874; U.S. PATENT NO. 7,812,875; U.S. PATENT NO. 7,812,876; U.S. PATENT NO. 7,812,877; U.S. PATENT NO. 7,812,878; U.S. PATENT NO. 7,812,879; U.S. PATENT NO. 7,812,880; U.S. PATENT NO. 7,812,881; U.S. PATENT NO. 7,812,882; U.S. PATENT NO. 7,812,883; U.S. PATENT NO. 7,812,884; U.S. PATENT NO. 7,812,885; U.S. PATENT NO. 7,812,886; U.S. PATENT NO. 7,812,887; U.S. PATENT NO. 7,812,888; U.S. PATENT NO. 7,812,889; U.S. PATENT NO. 7,812,890; U.S. PATENT NO. 7,812,891; U.S. PATENT NO. 7,812,892; U.S. PATENT NO. 7,812,893; U.S. PATENT NO. 7,812,894; U.S. PATENT NO. 7,812,895; U.S. PATENT NO. 7,812,896; U.S. PATENT NO. 7,812,897; U.S. PATENT NO. 7,812,898; U.S. PATENT NO. 7,812,899; U.S. PATENT NO. 7,812,900; U.S. PATENT NO. 7,812,901; U.S. PATENT NO. 7,812,902; U.S. PATENT NO. 7,812,903; U.S. PATENT NO. 7,812,904; U.S. PATENT NO. 7,812,905; U.S. PATENT NO. 7,812,906; U.S. PATENT NO. 7,812,907; U.S. PATENT NO. 7,812,908; U.S. PATENT NO. 7,812,909; U.S. PATENT NO. 7,812,910; U.S. PATENT NO. 7,812,911; U.S. PATENT NO. 7,812,912; U.S. PATENT NO. 7,812,913; U.S. PATENT NO. 7,812,914; U.S. PATENT NO. 7,812,915; U.S. PATENT NO. 7,812,916; U.S. PATENT NO. 7,812,917; U.S. PATENT NO. 7,812,918; U.S. PATENT NO. 7,812,919; U.S. PATENT NO. 7,812,920; U.S. PATENT NO. 7,812,921; U.S. PATENT NO. 7,812,922; U.S. PATENT NO. 7,812,923; U.S. PATENT NO. 7,812,924; U.S. PATENT NO. 7,812,925; U.S. PATENT NO. 7,812,926; U.S. PATENT NO. 7,812,927; U.S. PATENT NO. 7,812,928; U.S. PATENT NO. 7,812,929; U.S. PATENT NO. 7,812,930; U.S. PATENT NO. 7,812,931; U.S. PATENT NO. 7,812,932; U.S. PATENT NO. 7,812,933; U.S. PATENT NO. 7,812,934; U.S. PATENT NO. 7,812,935; U.S. PATENT NO. 7,812,936; U.S. PATENT NO. 7,812,937; U.S. PATENT NO. 7,812,938; U.S. PATENT NO. 7,812,939; U.S. PATENT NO. 7,812,940; U.S. PATENT NO. 7,812,941; U.S. PATENT NO. 7,812,942; U.S. PATENT NO. 7,812,943; U.S. PATENT NO. 7,812,944; U.S. PATENT NO. 7,812,945; U.S. PATENT NO. 7,812,946; U.S. PATENT NO. 7,812,947; U.S. PATENT NO. 7,812,948; U.S. PATENT NO. 7,812,949; U.S. PATENT NO. 7,812,950; U.S. PATENT NO. 7,812,951; U.S. PATENT NO. 7,812,952; U.S. PATENT NO. 7,812,953; U.S. PATENT NO. 7,812,954; U.S. PATENT NO. 7,812,955; U.S. PATENT NO. 7,812,956; U.S. PATENT NO. 7,812,957; U.S. PATENT NO. 7,812,958; U.S. PATENT NO. 7,812,959; U.S. PATENT NO. 7,812,960; U.S. PATENT NO. 7,812,961; U.S. PATENT NO. 7,812,962; U.S. PATENT NO. 7,812,963; U.S. PATENT NO. 7,812,964; U.S. PATENT NO. 7,812,965; U.S. PATENT NO. 7,812,966; U.S. PATENT NO. 7,812,967; U.S. PATENT NO. 7,812,968; U.S. PATENT NO. 7,812,969; U.S. PATENT NO. 7,812,970; U.S. PATENT NO. 7,812,971; U.S. PATENT NO. 7,812,972; U.S. PATENT NO. 7,812,973; U.S. PATENT NO. 7,812,974; U.S. PATENT NO. 7,812,975; U.S. PATENT NO. 7,812,976; U.S. PATENT NO. 7,812,977; U.S. PATENT NO. 7,812,978; U.S. PATENT NO. 7,812,979; U.S. PATENT NO. 7,812,980; U.S. PATENT NO. 7,812,981; U.S. PATENT NO. 7,812,982; U.S. PATENT NO. 7,812,983; U.S. PATENT NO. 7,812,984; U.S. PATENT NO. 7,812,985; U.S. PATENT NO. 7,812,986; U.S. PATENT NO. 7,812,987; U.S. PATENT NO. 7,812,988; U.S. PATENT NO. 7,812,989; U.S. PATENT NO. 7,812,990; U.S. PATENT NO. 7,812,991; U.S. PATENT NO. 7,812,992; U.S. PATENT NO. 7,812,993; U.S. PATENT NO. 7,812,994; U.S. PATENT NO. 7,812,995; U.S. PATENT NO. 7,812,996; U.S. PATENT NO. 7,812,997; U.S. PATENT NO. 7,812,998; U.S. PATENT NO. 7,812,999; U.S. PATENT NO. 7,813,000.

DATE: 07/21/14	
DESIGNED: N/A	DRAWN: NDG
CHECKED: N/A	APPROVED: XXX
PROJECT NUMBER:	
SHEET: OF N/A	

FOR REFERENCE ONLY. TO BE CONSTRUCTED AS PART OF FILING 1.

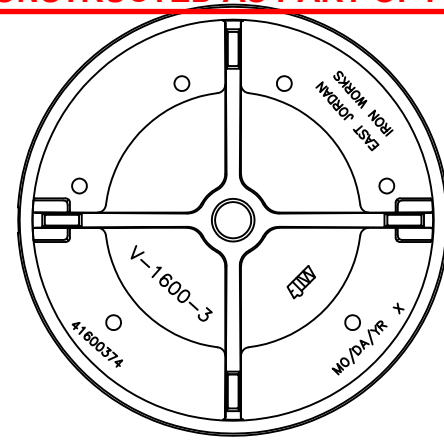
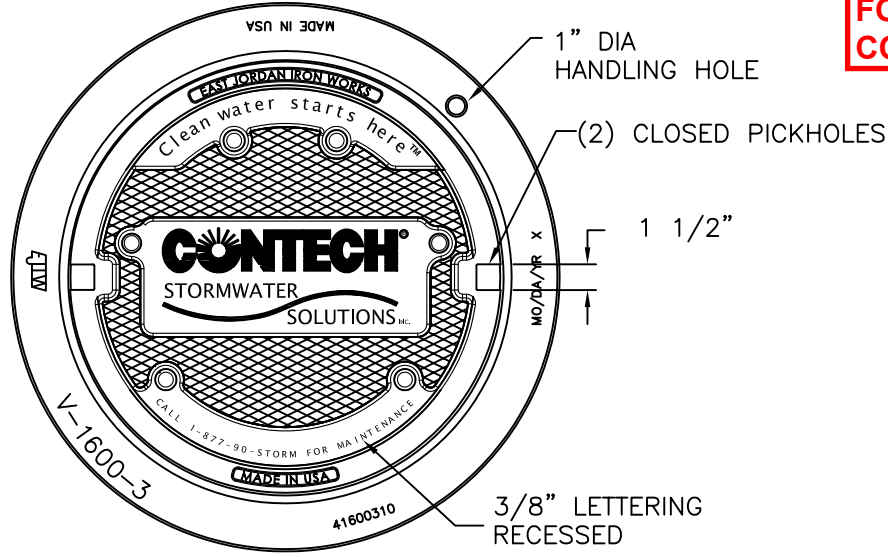

COVER BACK

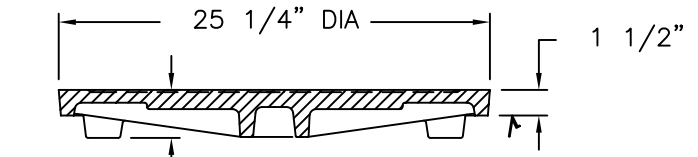

COVER SECTION

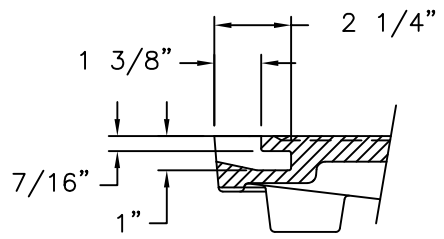

PICKHOLE DETAIL

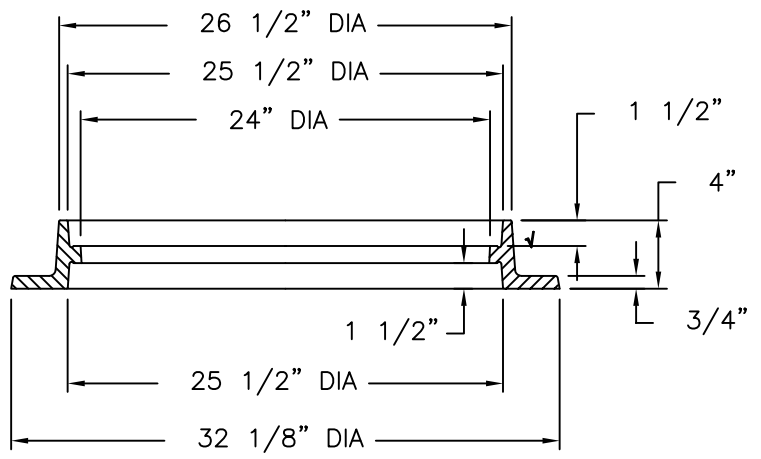

RING SECTION

EJIW EAST JORDAN
 IRON WORKS EST.1883

800-626-4653
 www.ejiw.com
 MADE IN USA

PRODUCT NUMBER

41600389

CATALOG NUMBER

V1600-3

REVERSIBLE RING & COVER ASSEMBLY

LOAD RATING

HEAVY DUTY HS-20

COATING

UNDIPPED

ESTIMATED WEIGHT

COVER: 135 LBS
 RING: 120 LBS
 UNIT: 255 LBS

MATERIAL SPECIFICATION

RING - GRAY IRON
 ASTM A48 CL35B
 COVER - GRAY IRON
 ASTM A48 CL35B

OPEN AREA

N/A

√DESIGNATES MACHINE SURFACE

DRAWN
 DEW

DATE
 05/02/08

LAST REVISED

DATE

REFERENCE INFORMATION

41600310
 41600374

CONFIDENTIAL: This drawing is the property of East Jordan Iron Works, Inc. and embodies confidential information, trade secret information, and/or know how that is the property of East Jordan Iron Works, Inc. © Copyright 2006 East Jordan Iron Works, Inc.

FOR REFERENCE ONLY. TO BE CONSTRUCTED AS PART OF FILING 1.

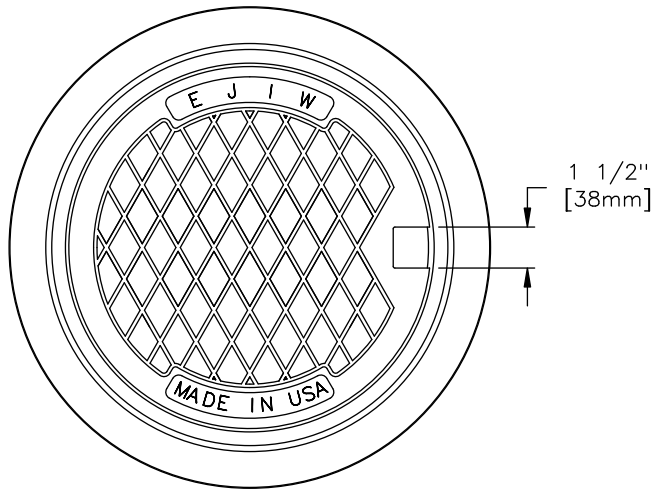

RING BOTTOM FLANGE

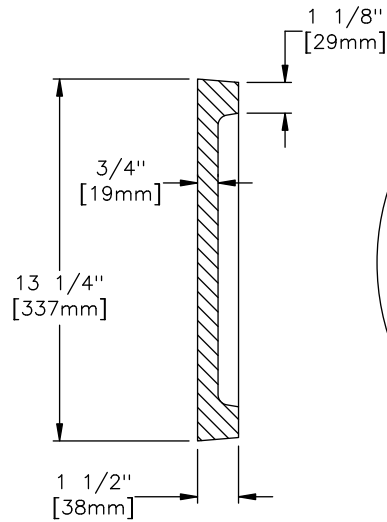

COVER SECTION

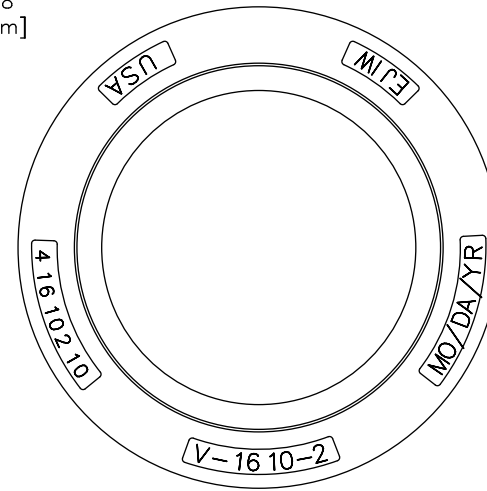

RING TOP FLANGE

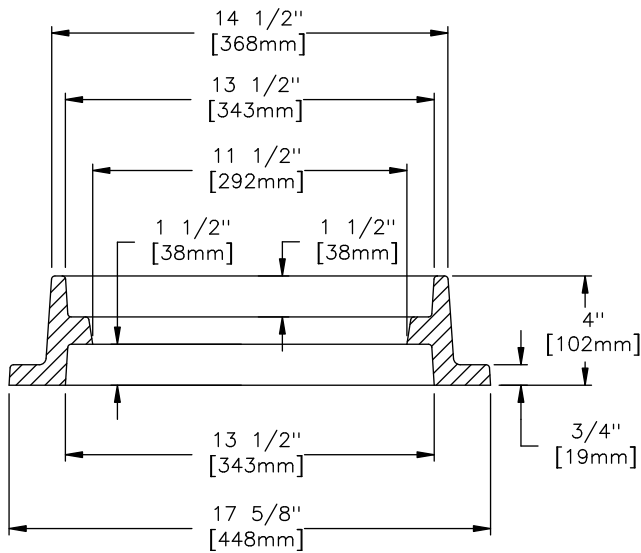

RING SECTION

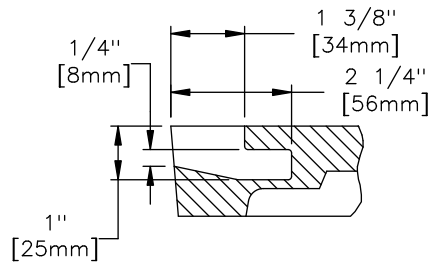

PICKHOLE DETAIL

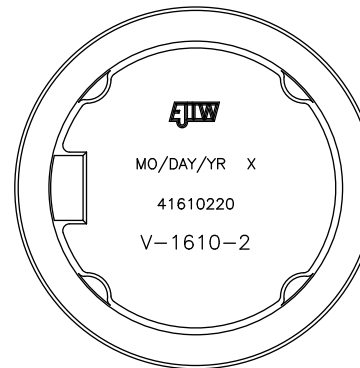

COVER BACK

NOTE:
RING IS REVERSIBLE AND CAN BE
INSTALLED AS A TOP FLANGE UNIT

**EAST JORDAN
IRON WORKS, INC.**

P.O. BOX 439
EAST JORDAN, MI. 49727
1-800-874-4100
FAX 231-536-4458

DRAWN DAL	DATE 06/12/03
APPROVED	DATE

ASSEMBLY

PRODUCT NO.

41610201

CATALOG NO.

V-1610-2

REF. SALES DRAWING
41610210
41610220

EST. WT.

COVER: 36 LBS 16kg
RING: 45 LBS 20kg
TOTAL: 81 LBS 37kg

OPEN AREA

N/A

MAT'L SPEC.

COVER - GRAY IRON
ASTM A48 CL35B
RING - GRAY IRON
ASTM A48 CL35B

LOAD RATING

HEAVY DUTY



**INLINE
HYDRAULIC CALCULATIONS**
COMPARK SOUTH
PARKER, CO
542946-10



DESIGN PARAMETERS

CDS Model No. =	CDS3030
Design Treatment Flow =	3.0 cfs
Peak Design Flow =	29.20 cfs
Peak Design Return Interval =	100 year
Rim Elevation @ US Structure	5843.08 ft

DETAILED CALCULATIONS

TREATMENT FLOW

Tailwater Condition at Outfall, EL₀

$$EL_0 = \underline{5,830.16} \text{ ft (invert plus depth of flow at D/S outlet)}$$

Exit Loss from DownStream Pipe, h₁

$$h_1 = k * [V^2 / (2*g)]$$

where,

$$k = \underline{1.00}$$

$$V = Q / A_F$$

$$= \underline{7.48} \text{ fps}$$

$$h_1 = \underline{0.87} \text{ ft}$$

$$EGL_1 = EL_0 + h_1$$

$$= \underline{5831.03} \text{ ft}$$

Head Loss Through Downstream Pipe, h₂

Friction Losses, h₂

$$h_2 = S_{EGL} * L$$

where,

$$L = \underline{12} \text{ ft}$$

$$S_{EGL} = [(Q * n) / (1.49 * A_F * R^{2/3})]^2$$

where,

Pipe Characteristics

$$\text{Dia.} = \underline{24} \text{ in}$$

$$S_{PIPE} = \underline{0.0310} \text{ ft/ft}$$

$$n = \underline{0.013}$$

Flow Characteristics

$$d_F = \underline{0.37} \text{ ft}$$

$$A_F = \underline{0.40} \text{ sf}$$

$$P_W = \underline{1.78} \text{ ft}$$

$$R = \underline{0.23} \text{ ft}$$

Head Loss Through Downstream Pipe, h_2 (cont.'d)

7/26/2016

$$S_{EGL} = \underline{0.03112} \text{ ft / ft}$$

$$h_2 = \underline{0.3734} \text{ ft}$$

$$\begin{aligned} EGL_2' &= EGL_1 + h_2 \\ &= \underline{5831.40} \text{ ft} \end{aligned}$$

Check Entrance Condition for Critical Depth Control

$$EL_{CDS \text{ Inv.}} = \underline{5830.16} \text{ ft}$$

$$d_c = \underline{0.61} \text{ ft}$$

$$\begin{aligned} EGL_C &= EL_{CDS \text{ Inv.}} + d_c + V_{dc}^2 / (2 * g) \\ &= \underline{5830.98} \text{ ft} \end{aligned}$$

Identify Controlling EGL

Flow enters pipe at critical depth, EGL_C controls.

$$EGL_2 = \underline{5830.98} \text{ ft}$$

Re-entry Loss into DownStream Pipe, h_3

$$h_3 = k * [V^2 / (2 * g)]$$

where,

$$k = \underline{0.20}$$

$$V = Q / A$$

$$= \underline{3.69} \text{ fps (area based on critical depth)}$$

$$h_3 = \underline{0.04} \text{ ft}$$

$$\begin{aligned} EGL_3' &= EGL_2 + h_3 \\ &= \underline{5831.03} \text{ ft} \end{aligned}$$

Oil Baffle Loss, h_4

$$h_4 = k * [V^2 / (2 * g)]$$

where,

$$k = \underline{1.00}$$

$$A_{\text{Baffle}} = \underline{6.49} \text{ sf}$$

$$V = Q / A_{\text{baffle}}$$

$$= \underline{0.46} \text{ fps}$$

$$h_4 = \underline{0.0033} \text{ ft}$$

$$\begin{aligned} EGL_4 &= EGL_3 + h_4 \\ &= \underline{5831.03} \text{ ft} \end{aligned}$$

Check Standard Weir Elevation

$$HL_{CDS} = \underline{0.67} \text{ ft}$$

$$\begin{aligned} EL_W' &= EGL_4 + HL_{CDS} \\ &= \underline{5831.70} \text{ ft} \end{aligned}$$

$$H_W' = EL_W' - EL_{CDS \text{ INV.}}$$

$$= \underline{1.54} \text{ ft, or } \underline{18.46} \text{ in}$$

$$\text{Std. Weir Height} = \underline{21} \text{ in}$$

Status **OK**

$$\text{Use } H_W = \underline{21} \text{ in, or } \underline{1.75} \text{ ft}$$

$$\begin{aligned} EL_W &= EL_{CDS \text{ INV.}} + H_W \\ &= \underline{5831.91} \text{ ft} \end{aligned}$$

PEAK CONVEYANCE FLOW

7/26/2016

Tailwater Condition at Outfall, EL_0

$$EL_0 = \underline{5,830.90} \text{ ft (tailwater condition per engineer, 100-yr)}$$

Exit Loss from DownStream Pipe, h_1

$$h_1 = k * [V^2 / (2*g)]$$

where,

$$k = \underline{1.00}$$
$$V = Q / A_F$$
$$= \underline{13.89} \text{ fps}$$

$$h_1 = \underline{2.99} \text{ ft}$$

$$EGL_1 = EL_0 + h_1$$
$$= \underline{5833.89} \text{ ft}$$

Head Loss Through Downstream Pipe, h_2

Friction Losses, h_2

$$h_2 = S_{EGL} * L$$

where,

$$L = \underline{12} \text{ ft}$$

$$S_{EGL} = [(Q * n) / (1.49 * A_F * R^{2/3})]^2$$

where,

Pipe Characteristics

$$\text{Dia.} = \underline{24} \text{ in}$$
$$S_{PIPE} = \underline{0.0310} \text{ ft/ft}$$
$$n = \underline{0.013}$$

Flow Characteristics

$$d_n = \underline{1.27} \text{ ft}$$
$$A_F = \underline{2.10} \text{ sf}$$
$$P_W = \underline{3.69} \text{ ft}$$
$$R = \underline{0.57} \text{ ft}$$

$$S_{EGL} = \underline{0.0310} \text{ ft / ft}$$

$$h_2 = \underline{0.37} \text{ ft}$$

$$EGL_2' = EGL_1 + h_2$$
$$= \underline{5834.27} \text{ ft}$$

Check Entrance Condition for Critical Depth Control

$$EL_{CDS \text{ Inv.}} = \underline{5830.16} \text{ ft}$$

$$d_c = \underline{1.91} \text{ ft}$$

$$EGL_C = EL_{CDS \text{ Inv.}} + d_c + V_{dc}^2 / (2*g)$$
$$= \underline{5833.46} \text{ ft}$$

Identify Controlling EGL

Flow enters pipe at critical depth, EGL_C controls.

$$EGL_2 = \underline{5833.46} \text{ ft}$$

Re-entry Loss into DownStream Pipe, h_3

7/26/2016

$$h_3 = k * [V^2 / (2*g)]$$

where,

$$k = \frac{0.20}{}$$

$$V = Q / A_F$$

$$= \frac{9.46}{} \text{ fps (area based on critical depth)}$$

$$h_3 = \frac{0.28}{} \text{ ft}$$

$$EGL_3 = EGL_2 + h_3$$

$$= \frac{5833.73}{} \text{ ft}$$

Oil Baffle Loss, h_4

$$h_4 = k * [V^2 / (2*g)]$$

where,

$$k = \frac{0.00}{} \text{ (Skirted-baffle model)}$$

$$A_{\text{Baffle}} = \frac{6.49}{} \text{ sf}$$

$$V = Q / A_{\text{Baffle}}$$

$$= \frac{4.50}{} \text{ fps}$$

$$h_4 = \frac{0.00}{} \text{ ft}$$

$$EGL_4 = EGL_3 + h_4$$

$$= \frac{5833.73}{} \text{ ft}$$

$$HGL_4 = EGL_4 - [V_P^2 / (2*g)]$$

$$= \frac{5832.35}{} \text{ ft}$$

Head over Diversion Weir, h_5

Elevation of Weir

$$EL_{\text{Weir}} = \frac{5831.91}{} \text{ ft (established above)}$$

Headloss for Free Discharge Condition

$$h_{5a} = [Q / (C * L)]^{2/3}$$

where,

$$C = \frac{3.1}{}$$

$$L = \frac{3.00}{} \text{ ft}$$

$$h_{5a} = \frac{2.14}{} \text{ ft}$$

$$EGL_{5a} = EL_{\text{Weir}} + h_{5a}$$

$$= \frac{5834.05}{} \text{ ft}$$

Headloss for Submerged Condition

$$d_{\text{Sub}} = \frac{0.44}{} \text{ ft (depth of submergence)}$$

$$h_{5b} = \frac{1.76}{} \text{ ft (separate submerged weir calc.)}$$

$$EGL_{5b} = EGL_4 + h_{5b}$$

$$= \frac{5835.50}{} \text{ ft}$$

Identify EGL U/S of Weir

The discharge condition is Submerged, therefore

$$EGL_5 = \frac{5835.50}{} \text{ ft}$$

Expansion Loss from U/S Pipe, h_6

7/26/2016

$$h_6 = k * [V^2 / (2 * g)]$$

where,

$$k = \underline{0.30}$$

$$V = Q / A_F$$

$$= \underline{9.30} \text{ fps}$$

$$h_6 = \underline{0.40} \text{ ft}$$

$$EGL_6 = EGL_5 + h_6$$

$$= \underline{5835.90} \text{ ft}$$

Head Loss Through Upstream Pipe, h_7 Friction Losses, h_7

$$h_7 = S_{EGL} * L$$

where,

$$L = \underline{18} \text{ ft}$$

$$S_{EGL} = [(Q * n) / (1.49 * A_F * R^{2/3})]^2$$

where,

Pipe Characteristics

$$\text{Dia.} = \underline{24} \text{ in}$$

$$S_{PIPE} = \underline{0.0310} \text{ ft/ft}$$

$$n = \underline{0.013}$$

Flow Characteristics

$$d_n = \underline{2.00} \text{ ft}$$

$$A_F = \underline{3.14} \text{ sf}$$

$$P_W = \underline{6.28} \text{ ft}$$

$$R = \underline{0.50} \text{ ft}$$

$$S_{EGL} = \underline{0.0166} \text{ ft / ft}$$

$$h_7 = \underline{0.30} \text{ ft}$$

$$EGL_7' = EGL_6 + h_7$$

$$= \underline{5836.20} \text{ ft}$$

Check Entrance Condition for Critical Depth Control

$$EL_{U/S \text{ Inv.}} = \underline{5830.72} \text{ ft}$$

$$d_c = \underline{1.91} \text{ ft}$$

$$EGL_C = EL_{CDS \text{ Inv.}} + d_c + V_{dc}^2 / (2 * g)$$

$$= \underline{5834.01} \text{ ft}$$

Identify Controlling EGL

Friction based EGL controls.

$$EGL_7 = \underline{5836.20} \text{ ft}$$

$$HGL_7 = EGL_7 - [V^2 / (2 * g)]$$

$$= \underline{5834.85} \text{ ft}$$

$$\text{Freeboard} = \underline{8.23} \text{ ft (at first upstream structure)}$$

APPENDIX D

Drainage Basin Map

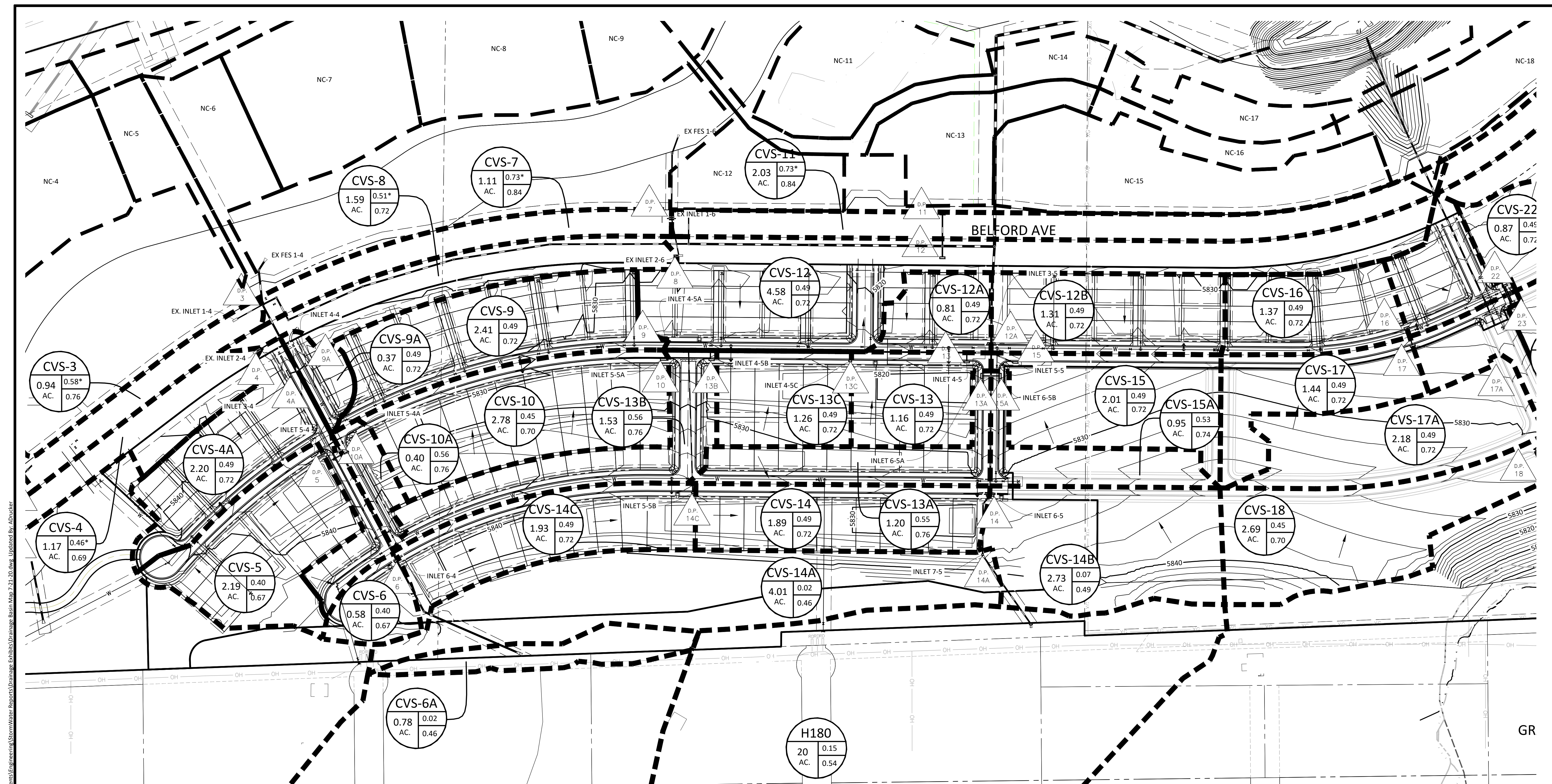

2 YEAR STORM

Basin ID	Drainage Point	Area (Ac)	Runoff Coefficient	Inlet	Storm Sewer	Remarks	
CVS-1 (Inlet 1-3)	1	3.85	0.58	4.7	4.7	0.0 8.9 3.1% 24	
CVS-2 (Inlet 2-3)	2	1.42	0.66	4.3	0.97	4.2	4.2 4.2 0.0 4.2 100% 24
CVS-3 (Inlet 1-4)	3	0.94	0.52	4.4	0.52	2.3	2.3 2.3 0.0 2.3 17% 18
CVS-4 (Inlet 2-4)	4	1.17	0.41	0.41	0.41	2.5	2.5 2.5 0.0 2.5 39% 18
CVS-5 (Inlet 3-4)	5	2.19	0.40	0.40	0.40	3.9	3.9 3.9 0.0 3.9 10% 18
CVS-6 (Inlet 4-4)	6	0.36	0.50	0.40	0.37	3.4	3.4 3.4 0.0 3.4 10% 18
CVS-7 (Inlet 1-6)	7	1.11	0.52	0.47	0.01	1.1	1.1 1.1 0.0 1.1 7% 36
CVS-8 (Inlet 2-6)	8	1.59	0.49	0.72	0.29	2.9	2.9 2.9 0.0 2.9 10% 24
CVS-9 (Inlet 3-6)	9	2.41	0.49	0.72	0.29	4.1	4.1 4.1 0.0 4.1 12% 18
CVS-10 (Inlet 4-6)	10	2.78	0.45	0.70	0.29	4.2	4.2 4.2 0.0 4.2 12% 18
CVS-11 (Inlet 5-6)	11	2.03	0.84	0.73	0.84	4.9	4.9 4.9 0.0 4.9 12% 36
CVS-12 (Inlet 1-5)	12	4.58	0.49	0.72	0.29	7.9	7.9 7.9 0.0 7.9 36% 36
CVS-13 (Inlet 2-5)	13	0.81	0.72	0.49	0.41	1.6	1.6 1.6 0.0 1.6 19% 42
CVS-14 (Inlet 3-5)	14	1.31	0.68	0.49	0.38	2.3	2.3 2.3 0.0 2.3 19% 42
CVS-15 (Inlet 4-5)	15	1.16	0.74	0.49	0.57	2.4	2.4 2.4 0.0 2.4 36% 18
CVS-16 (Inlet 5-5)	16	1.37	0.49	0.72	0.29	2.6	2.6 2.6 0.0 2.6 10% 18
CVS-17 (Inlet 6-5)	17	1.31	0.49	0.72	0.29	3.4	3.4 3.4 0.0 3.4 10% 18
CVS-18 (Inlet 7-5)	18	1.16	0.49	0.72	0.29	3.3	3.3 3.3 0.0 3.3 10% 18
CVS-19 (Inlet 8-5)	19	1.26	0.49	0.72	0.29	3.5	3.5 3.5 0.0 3.5 10% 18
CVS-20 (Inlet 9-5)	20	1.16	0.49	0.72	0.29	3.5	3.5 3.5 0.0 3.5 10% 18
CVS-21 (Inlet 10-5)	21	1.16	0.49	0.72	0.29	3.5	3.5 3.5 0.0 3.5 10% 18
CVS-22 (Inlet 11-5)	22	0.87	0.49	0.72	0.29	3.3	3.3 3.3 0.0 3.3 10% 18
CVS-23 (Inlet 12-5)	23	0.87	0.49	0.72	0.29	3.3	3.3 3.3 0.0 3.3 10% 18
CVS-24 (Inlet 13-5)	24	0.87	0.49	0.72	0.29	3.3	3.3 3.3 0.0 3.3 10% 18
CVS-25 (Inlet 14-5)	25	0.87	0.49	0.72	0.29	3.3	3.3 3.3 0.0 3.3 10% 18
CVS-26 (Inlet 15-5)	26	0.87	0.49	0.72	0.29	3.3	3.3 3.3 0.0 3.3 10% 18
CVS-27 (Inlet 16-5)	27	0.87	0.49	0.72	0.29	3.3	3.3 3.3 0.0 3.3 10% 18
CVS-28 (Inlet 17-5)	28	0.87	0.49	0.72	0.29	3.3	3.3 3.3 0.0 3.3 10% 18
CVS-29 (Inlet 18-5)	29	0.87	0.49	0.72	0.29	3.3	3.3 3.3 0.0 3.3 10% 18
CVS-30 (Inlet 19-5)	30	0.87	0.49	0.72	0.29	3.3	3.3 3.3 0.0 3.3 10% 18
CVS-31 (Inlet 20-5)	31	0.87	0.49	0.72	0.29	3.3	3.3 3.3 0.0 3.3 10% 18
CVS-32 (Inlet 21-5)	32	0.87	0.49	0.72	0.29	3.3	3.3 3.3 0.0 3.3 10% 18
CVS-33 (Inlet 22-5)	33	0.87	0.49	0.72	0.29	3.3	3.3 3.3 0.0 3.3 10% 18
CVS-34 (Inlet 23-5)	34	0.87	0.49	0.72	0.29	3.3	3.3 3.3 0.0 3.3 10% 18
CVS-35 (Inlet 24-5)	35	0.87	0.49	0.72	0.29	3.3	3.3 3.3 0.0 3.3 10% 18
CVS-36 (Inlet 25-5)	36	0.87	0.49	0.72	0.29	3.3	3.3 3.3 0.0 3.3 10% 18
CVS-37 (Inlet 26-5)	37	0.87	0.49	0.72	0.29	3.3	3.3 3.3 0.0 3.3 10% 18
CVS-38 (Inlet 27-5)	38	0.87	0.49	0.72	0.29	3.3	3.3 3.3 0.0 3.3 10% 18
CVS-39 (Inlet 28-5)	39	0.87	0.49	0.72	0.29	3.3	3.3 3.3 0.0 3.3 10% 18
CVS-40 (Inlet 29-5)	40	0.87	0.49	0.72	0.29	3.3	3.3 3.3 0.0 3.3 10% 18
CVS-41 (Inlet 30-5)	41	0.87	0.49	0.72	0.29	3.3	3.3 3.3 0.0 3.3 10% 18
CVS-42 (Inlet 31-5)	42	0.87	0.49	0.72	0.29	3.3	3.3 3.3 0.0 3.3 10% 18
CVS-43 (Inlet 32-5)	43	0.87	0.49	0.72	0.29	3.3	3.3 3.3 0.0 3.3 10% 18
CVS-44 (Inlet 33-5)	44	0.87	0.49	0.72	0.29	3.3	3.3 3.3 0.0 3.3 10% 18
CVS-45 (Inlet 34-5)	45	0.87	0.49	0.72	0.29	3.3	3.3 3.3 0.0 3.3 10% 18
CVS-46 (Inlet 35-5)	46	0.87	0.49	0.72	0.29	3.3	3.3 3.3 0.0 3.3 10% 18
CVS-47 (Inlet 36-5)	47	0.87	0.49	0.72	0.29	3.3	3.3 3.3 0.0 3.3 10% 18
CVS-48 (Inlet 37-5)	48	0.87	0.49	0.72	0.29	3.3	3.3 3.3 0.0 3.3 10% 18
CVS-49 (Inlet 38-5)	49	0.87	0.49	0.72	0.29	3.3	3.3 3.3 0.0 3.3 10% 18
CVS-50 (Inlet 39-5)	50	0.87	0.49	0.72	0.29	3.3	3.3 3.3 0.0 3.3 10% 18
CVS-51 (Inlet 40-5)	51	0.87	0.49	0.72	0.29	3.3	3.3 3.3 0.0 3.3 10% 18
CVS-52 (Inlet 41-5)	52	0.87	0.49	0.72	0.29	3.3	3.3 3.3 0.0 3.3 10% 18
CVS-53 (Inlet 42-5)	53	0.87	0.49	0.72	0.29	3.3	3.3 3.3 0.0 3.3 10% 18
CVS-54 (Inlet 43-5)	54	0.87	0.49	0.72	0.29	3.3	3.3 3.3 0.0 3.3 10% 18
CVS-55 (Inlet 44-5)	55	0.87	0.49	0.72	0.29	3.3	3.3 3.3 0.0 3.3 10% 18
CVS-56 (Inlet 45-5)	56	0.87	0.49	0.72	0.29	3.3	3.3 3.3 0.0 3.3 10% 18
CVS-57 (Inlet 46-5)	57	0.87	0.49	0.72	0.29	3.3	3.3 3.3 0.0 3.3 10% 18
CVS-58 (Inlet 47-5)	58	0.87	0.49	0.72	0.29	3.3	3.3 3.3 0.0 3.3 10% 18
CVS-59 (Inlet 48-5)	59	0.87	0.49	0.72	0.29	3.3	3.3 3.3 0.0 3.3 10% 18
CVS-60 (Inlet 49-5)	60	0.87	0.49	0.72	0.29	3.3	3.3 3.3 0.0 3.3 10% 18
CVS-61 (Inlet 50-5)	61	0.87	0.49	0.72	0.29	3.3	3.3 3.3 0.0 3.3 10% 18
CVS-62 (Inlet 51-5)	62	0.87	0.49	0.72	0.29	3.3	3.3 3.3 0.0 3.3 10% 18
CVS-63 (Inlet 52-5)	63	0.87	0.49	0.72	0.29	3.3	3.3 3.3 0.0 3.3 10% 18
CVS-64 (Inlet 53-5)	64	0.87	0.49	0.72	0.29	3.3	3.3 3.3 0.0 3.3 10% 18
CVS-65 (Inlet 54-5)	65	0.87	0.49	0.72	0.29	3.3	3.3 3.3 0.0 3.3 10% 18
CVS-66 (Inlet 55-5)	66	0.87	0.49	0.72	0.29	3.3	3.3 3.3 0.0 3.3 10% 18
CVS-67 (Inlet 56-5)	67	0.87	0.49	0.72	0.29	3.3	3.3 3.3 0.0 3.3 10% 18
CVS-68 (Inlet 57-5)	68	0.87	0.49	0.72	0.29	3.3	3.3 3.3 0.0 3.3 10% 18
CVS-69 (Inlet 58-5)	69	0.87	0.49	0.72	0.29	3.3	3.3 3.3 0.0 3.3 10% 18
CVS-70 (Inlet 59-5)	70	0.87	0.49	0.72	0.29	3.3	3.3 3.3 0.0 3.3 10% 18
CVS-71 (Inlet 60-5)	71	0.87	0.49	0.72	0.29	3.3	3.3 3.3 0.0 3.3 10% 18
CVS-72 (Inlet 61-5)	72	0.87	0.49	0.72	0.29	3.3	3.3 3.3 0.0 3.3 10% 18
CVS-73 (Inlet 62-5)	73	0.87	0.49	0.72	0.29	3.3	3.3 3.3 0.0 3.3 10% 18
CVS-74 (Inlet 63-5)	74	0.87	0.49	0.72	0.29	3.3	3.3 3.3 0.0 3.3 10% 18
CVS-75 (Inlet 64-5)	75	0.87	0.49	0.72	0.29	3.3	3.3 3.3 0.0 3.3 10% 18
CVS-76 (Inlet 65-5)	76	0.87	0.49	0.72	0.29	3.3	3.3 3.3 0.0 3.3 10% 18
CVS-77 (Inlet 66-5)	77	0.87	0.49	0.72	0.29	3.3	3.3 3.3 0.0 3.3 10% 18
CVS-78 (Inlet 67-5)	78	0.87	0.49	0.72	0.29	3.3	3.3 3.3 0.0 3.3 10% 18
CVS-79 (Inlet 68-5)	79	0.87	0.49	0.72	0.29	3.3	3.3 3.3 0.0 3.3 10% 18
CVS-80 (Inlet 69-5)	80	0.87	0.49	0.72	0.29	3.3	3.3 3.3 0.0 3.3 10% 18
CVS-81 (Inlet 70-5)	81	0.87	0.49	0.72	0.29	3.3	3.3 3.3 0.0 3.3 10% 18
CVS-82 (Inlet 71-5)	82	0.87	0.49	0.72	0.29	3.3	3.3 3.3 0.0 3.3 10% 18
CVS-83 (Inlet 72-5)	83	0.87	0.49	0.72	0.29	3.3	3.3 3.3 0.0 3.3 10% 18
CVS-84 (Inlet 73-5)	84	0.87	0.49	0.72	0.29	3.3	3.3 3.3 0.0 3.3 10% 18
CVS-85 (Inlet 74-5)	85	0.87	0.49	0.72	0.29	3.3	3.3 3.3 0.0 3.3 10% 18
CVS-86 (Inlet 75-5)	86	0.87	0.49	0.72	0.29	3.3	3.3 3.3 0.0 3.3 10% 18
CVS-87 (Inlet 76-5)	87	0.87	0.49	0.72	0.29	3.3	3.3 3.3 0.0 3.3 10% 18
CVS-88 (Inlet 77-5)	88	0.87	0.49	0.72	0.29	3.3	3.3 3.3 0.0 3.3 10% 18
CVS-89 (Inlet 78-5)	89	0.87	0.49	0.72	0.29	3.3	3.3 3.3 0.0 3.3 10% 18
CVS-90 (Inlet 79-5)	90	0.87	0.49	0.72	0.29	3.3	3.3 3.3 0.0 3.3 10% 18
CVS-91 (Inlet 80-5)	91	0.87	0.49	0.72	0.29	3.3	3.3 3.3 0.0 3.3 10% 18
CVS-92 (Inlet 81-5)	92	0.87	0.49	0.72	0.29	3.3	3.3 3.3 0.0 3.3 10% 18
CVS-93 (Inlet 82-5)	93	0.87	0.49	0.72	0.29	3.3	3.3 3.3 0.0 3.3 10% 18
CVS-94 (Inlet 83-5)	94	0.87	0.49	0.72	0.29	3.3	3.3 3.3 0.0 3.3 10% 18
CVS-95 (Inlet 84-5)	95	0.87	0.49	0.72	0.29	3.3	3.3 3.3 0.0 3.3 10% 18
CVS-96 (Inlet 85-5)	96	0.87	0.49	0.72	0.29	3.3	3.3 3.3 0.0 3.3 10% 18
CVS-97 (Inlet 86-5)	97	0.87	0.49	0.72	0.29	3.3	3.3 3.3 0.0 3.3 10% 18
CVS-98 (Inlet 87-5)	98	0.87	0.49	0.72	0.29	3.3	3.3 3.3 0.0 3.3 10% 18
CVS-99 (Inlet 88-5)	99	0.87	0.49	0.72	0.29	3.3	3.3 3.3 0.0 3.3 10% 18
CVS-100 (Inlet 89-5)	100	0.87	0.49	0.72	0.29	3.3	3.3 3.3 0.0 3.3 10% 18

5 YEAR STORM

Basin ID	Drainage Point	Area (Ac)	Runoff Coefficient	Inlet	Storm Sewer	Remarks		
CVS-1 (Inlet 1-3)	1	3.85	0.93	4.3	1.27	5.5	5.5 5.5 0.0 5.5 3.1% 24	
CVS-2 (Inlet 2-3)	2	1.42	0.66	0.72	4.3	4.5	4.5 4.5 0.0 4.5 100% 24	
CVS-3 (Inlet 1-4)	3	0.94	0.62	0.58	4.4	0.54	2.4	2.4 2.4 0.0 2.4 17% 18
CVS-4 (Inlet 2-4)	4	1.17	0.41	0.46	5.0	0.53	2.6	2.6 2.6 0.0 2.6 39% 18
CVS-5 (Inlet 3-4)	5	2.19	0.40	0.42	3.9	0.92	4.0	4.0 4.0 0.0 4.0 10% 18
CVS-6 (Inlet 4-4)	6	0.36	0.50	0.40	0.37	1.1	1.1	1.1 1.1 0.0 1.1 7% 36
CVS-7 (Inlet 1-6)	7	1.11	0.52	0.47	0.01	1.1	1.1	1.1 1.1 0.0 1.1 7% 36
CVS-8 (Inlet 2-6)	8	1.59	0.49	0.72	0.29	3.0	3.0	3.0 3.0 0.0 3.0 10% 24
CVS-9 (Inlet 3-6)	9	2.41	0.49	0.72	0.29	4.1	4.1	4.1 4.1 0.0 4.1 12% 18
CVS-10 (Inlet 4-6)	10	2.78	0.45	0.70	0.29	4.3	4.3	4.3 4.3 0.0 4.3 12% 18
CVS-11 (Inlet 5-6)	11	2.03	0.84	0.73	0.84	4.3	4.3	4.3 4.3 0.0 4.3 12% 36
CVS-12 (Inlet 1-5)	12	4.58	0.49	0.72	0.29	7.9	7.9	7.9 7.9 0.0 7.9 36% 36
CVS-13 (Inlet 2-5)	13	0.81	0.72	0.49	0.41	1.6	1.6	1.6 1.6 0.0 1.6 19% 42
CVS-14 (Inlet 3-5)	14	1.31	0.68	0.49	0.38	2.3	2.3	2.3 2.3 0.0 2.3 19% 42
CVS-15 (Inlet 4-5)	15	1.16	0.74	0.49	0.57	2.4	2.4	2.4 2.4 0.0 2.4 36% 18
CVS-16 (Inlet 5-5)	16	1.37	0.49	0.72	0.29	2.6	2.6	2.6 2.6 0.0 2.6 10% 18
CVS-17 (Inlet 6-5)	17	1.31	0.49	0.72	0.29	3.4	3.4	3.4 3.4 0.0 3.4 10% 18
CVS-18 (Inlet 7-5)	18	1.16	0.49	0.72	0.29	3.3	3.3	3.3 3.3 0.0 3.3 10% 18
CVS-19 (Inlet 8-5)	19	1.26						