

SUBMITTAL



Submittal number	97.0	Date	01/13/2020
Project	TRAILS AT CROWFOOT F1 & 9	6954 N. CROWFOOT VALLEY RD. PARKER, CO 80134	
Project number	201810		
Spec section			
Subsection		Status	Open
Current action	Submitted	Ball in court	
Topic	TCF F1 Park Sports Fields and Courts		

Submitter	MICHAEL TOMAS SNYDER
Reviewer	
Cc	

Date submitted	01/13/2020	Submission due date	01/13/2020
Released for review	01/13/2020	Review due date	01/20/2020
Date returned		Required on site date	
Date closed			

Notes
Please see the attached ELCI Transmittal # 5: Park Sports Fields



Letter of Transmittal

To: Mike Snyder
Kelley Trucking Inc
6201 McIntyre St
Golden, CO 80403
Ph: (303)279-4150

Transmittal #: 5
Date: 1/9/2020
Job: 01-10-19013 Trails at Crowfoot Park

Subject: Submittal

- WE ARE SENDING YOU**
- | | |
|--|--|
| <input checked="" type="checkbox"/> Attached | <input type="checkbox"/> Under separate cover via the following items: |
| <input type="checkbox"/> Shop drawings | <input type="checkbox"/> Prints |
| <input type="checkbox"/> Copy of letter | <input type="checkbox"/> Change order |
| | <input type="checkbox"/> Plans |
| | <input type="checkbox"/> Samples |
| | <input type="checkbox"/> Specifications |
| | <input checked="" type="checkbox"/> Submittal |

Document Type	Copies	Date	No.	Description
Submittal	1		Sports Fields-1 Rev	Park Sports Fields

THESE ARE TRANSMITTED as checked below:

- | | | |
|--|---|---|
| <input checked="" type="checkbox"/> For approval | <input type="checkbox"/> Approved as submitted | <input type="checkbox"/> Resubmit ___ copies for approval |
| <input type="checkbox"/> For your use | <input type="checkbox"/> Approved as noted | <input type="checkbox"/> Submit ___ copies for distribution |
| <input type="checkbox"/> As requested | <input type="checkbox"/> Returned for corrections | <input type="checkbox"/> Return ___ corrected prints |
| <input type="checkbox"/> For review and comment | <input type="checkbox"/> Other | |
| <input type="checkbox"/> FOR BIDS DUE | <input type="checkbox"/> PRINTS RETURNED AFTER LOAN TO US | |

Remarks:

Copy To: Con Cockrum (Kelley Trucking Inc), Tim LaPointe (Environmental Landworks Co), Kate LaPointe (Environmental Landworks Co)

From: Jordan Salisbury (Environmental Landworks Co)

Signature: _____



Submittal

Job: 01-10-19013
Trails at Crowfoot Park
6594 N Crowfoot Valley Rd
Parker, CO 80134

Spec Section No: Sports Fields

Submittal No: 1

Revision No: 0

Sent Date: 1/9/2020

Spec Section Title:

Submittal Title: Park Sports Fields

Contractor:

Environmental Landworks Company

Contractor's Stamp

Kelley Trucking Inc
Mike Snyder

Architect's Stamp

Engineer's Stamp



Site Furnishings Product Submittals

Project: Trails at Crowfoot Park

Contract Job #: 19-013

Submission #: 3

Date: 1/9/2019

DESCRIPTION	MANUFACTURER	SUPPLIER
PARK SECTION		
Hooded Baseball Backstop	Patterson Williams Athletics	Recreation Plus
Baseball: Home Plate, Pitchers Rubber, Bases	G&S Solutions	
Basketball Goals	Patterson Williams Athletics	Renner
Basketball Court and Striping		Renner
Pickleball Nets	Patterson Williams Athletics	Renner
Pickleball Courts and Striping		Renner
Tennis Nets	Patterson Williams Athletics	Renner
Tennis Courts and Striping		Renner

NOTE: WORK WILL NOT BE PERFORMED WITHOUT APPROVAL

Submittal Approval:

Date:

Permanent Hooded Backstop

MODEL #1230-00

FRONT HEIGHT: 17'-6" H; FRONT WIDTH: 34' WITH NO PLANKS (1475 LBS)

**FRAMES AVAILABLE
STANDARD AS:**

- GALVANIZED
- POWDER COATED

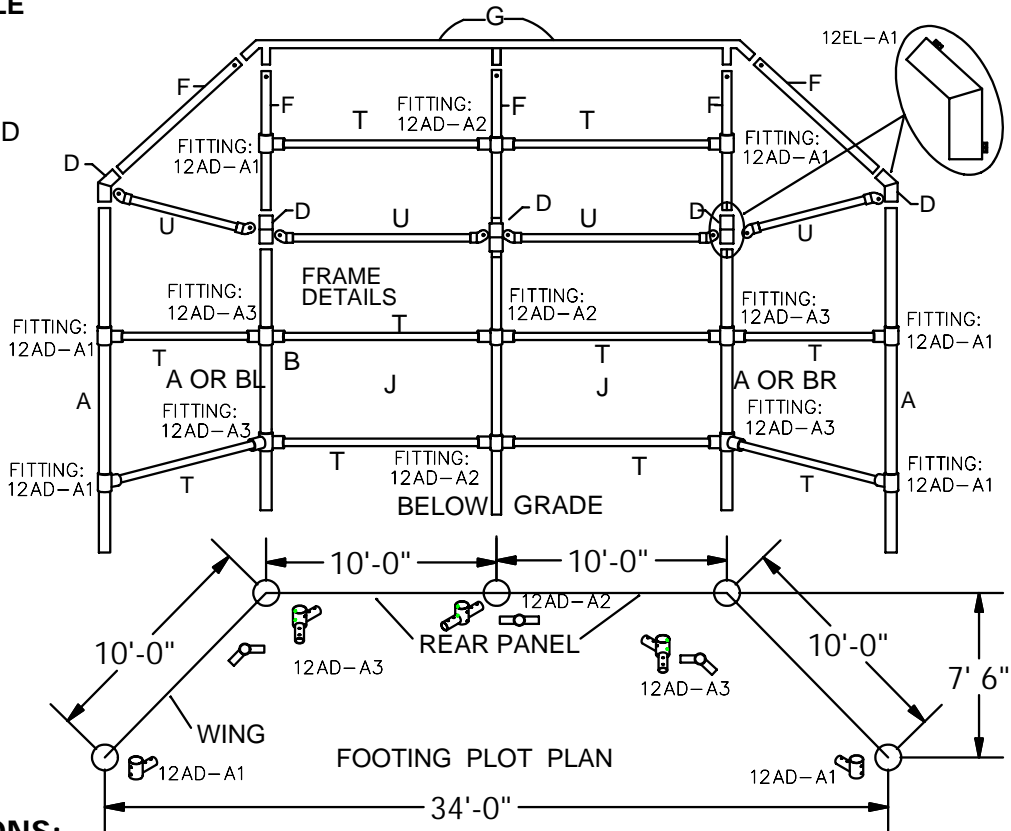

SPECIFICATIONS:

Posts: (A), (BL), (BR), and (F) are 2-3/8" O.D. galvanized steel.

Rails: (G) are 1-7/8" O.D. and (T) are 1-5/8" O.D. galvanized steel.

Elbow Fittings: Welded galvanized steel that fits 2-3/8" vertical and 2-3/8" hood supports.

Chain Link Fabric: 2" mesh galvanized after weaving: 9 ga on rear and side panels, 11 ga on hood.

Hardware: Tension bars and bands are galvanized steel. All fasteners are included.

Finish: All welds are treated with cold galvanizing compound. All fasteners are zinc plated for long rust-free service.

Warranty: 3 years

 <p>Patterson-Williams QUALITY ATHLETIC AND PARK EQUIPMENT SINCE 1919</p>	Date: 11-06-07	SPECIFICATION/INSTALLATION INSTRUCTIONS HOODED BASEBALL BACKSTOP
	Rev: SS91517	
	Drawn: AMC	MODEL NO.
	Sheet: 1 of 4	1230-00

GENERAL NOTES: Site must be level. Six 8" X 8" X 8" concrete blocks (half blocks) will be required in the bottom of holes to provide a means of post-height adjustment as well as to provide sufficient concrete footing below bottom of posts (See Page 3 & 4).

1. Determine location of backstop so the rear panel is perpendicular to a line running from 2nd base through home plate and so the wings are parallel with the sides of the diamond.
2. Dig holes according to footing plot plan and footing detail (See Page 3 & 4).
3. Center a half concrete block (8" X 8" X 8") in the bottom of each of the holes per footing detail. Adjust height so the top of the block is 30" below finished grade (See Page 3).
4. Start with an end post (Item A Page 4) and center the post in the hole so it rests on the block. Tops of posts for Model 1230 are to be 10' above finished grade. Adjust block height as necessary to achieve proper post height. Plumb and brace in position.
5. Repeat the same procedure for the adjacent corner post (Item A, BL Or BR).
6. Attach rail end caps to the horizontal rails (Item U). Insert 1-5/8" OD rails into rail end caps until fully seated. Drill through the end cap and the pipe with #25 drill bit provided. Hammer the #10 X 1/2" drive screws into holes until fully seated. Note: Keep rail end caps in line with each other.
7. Attach two horizontal rails (Item T) between the two posts, one at the finished grade level and one midway up the posts. Attach with brace bands and carriage bolts provided (See Attachment Detail).
8. Re-plumb posts and brace as necessary.
9. Set the adjacent center post (Item A Or C) in the hole on the concrete block and brace or hold in place.
10. Attach two horizontal rails (Item T) between the center post (Item A Or C) and the corner post (Item A or BL). Install as before; one at finished grade level and one midway up the post with brace bands and carriage bolts provided.
11. Re-plumb posts and brace as necessary.
12. Repeat the same procedure for each adjacent post until all of the five vertical posts are installed. Attach horizontal rails between posts as before. Make sure the posts are plumb. Pour concrete into footing holes and let the concrete set for three days before removal of bracing and completion of installation.
13. Slip the elbows for the upright posts (Item D) over the tops of the posts until seated. Using set screws, loosely tighten fitting in place.
14. Insert the five hood supports (Item F) into the elbows.
15. Align the hood supports by rotating the elbows. The hood supports on the corner and center posts (Items A Or BL, BR & C) should be rotated to face toward the infield and to be parallel to each other. The hood supports on the end posts (Item A) should be rotated so they are facing each other.
16. Slip the top horizontal rail (Item G) into the hood supports. Adjust the hood supports as necessary and make sure welded sleeves on top rail are fully seated.
17. Plumb frame and tighten all bolts.
18. Attach the shorter horizontal rails (Item T) at the top of the vertical posts between the elbow fittings with the 2-7/8" brace bands and carriage bolts provided (See Attachment Detail).
19. Install the horizontal rails (Item U) midway between the elbows and top rail. Tighten all bolts which secure all the horizontal rails.

Extremely Important

Dig footing holes according to layout & assemble post and rails with supplied pipe fittings. Do not pour concrete until entire frame is assembled.

 <p>Patterson-Williams ATHLETIC MFG. CO. QUALITY ATHLETIC AND PARK EQUIPMENT SINCE 1919</p>	Date: 11-06-07	SPECIFICATION/INSTALLATION INSTRUCTIONS	
	Rev: SS91517		HOODED BASEBALL BACKSTOP
	Drawn: AMC	MODEL NO.	1230-00
	Sheet: 2 of 4		

Mesh Installation: Separate the wire mesh as the heavier material (9 gauge) is to be used along the rear panel and the wings while the lighter material (11 gauge) is to be used on the hood. The mesh is cut to approximate size and shipped in rolls.

1. Cut four pieces of (9-gauge X 10 ft mesh) 10 ft long to be installed between the vertical posts of the rear panel and the wings. Attach each piece of mesh using one 10 ft tension bar on each side of the mesh along with tension bands and bolts provided. Use tension bands on 18 to 20 inch centers. The mesh must be tight, remove one or two strands as necessary to achieve proper tension (See Attachment Detail).
2. Secure the mesh to the top, center and bottom horizontal rails with tie wires every 12 inches (See Attachment Detail)
3. The mesh will overlap the top planks. Install the drilled tension bar in the mesh about 3" to 6" from the top edge of the highest plank. Pull tight and drill 5/16" diameter holes through the planks using the holes in the tension bar for drilling location. Secure with 5/16" x 2-1/2" carriage bolts, flat washers, lock washers and nuts. Note: This will keep the baseballs from falling behind planks.
4. Cut one piece of (11ga X 10 ft. mesh) 20 ft long. Attach the mesh to the rear panel using one tension bar on each end of the piece along with tension bands and hardware provided. Tension bands should be used on 18 to 20 inch centers. The mesh must be tight, remove strands as necessary to achieve proper tension.
5. Secure the mesh to the top, center and bottom horizontal rails of the hood supports with 7-inch tie wires every 12 inches (See Attachment Detail).
6. Cut a 10 ft long piece of 11ga mesh into a triangle to cover the remainder of the hooded area. Use the hood as a template.
7. Install two 10 ft. tension bars in each triangular mesh piece along the two edges where the wire ends are NOT twisted together (knuckled salvage edge). Attach the mesh in the corners of the hood so the edge of mesh without tension bar is along the horizontal rail. Use tension bands on 18 to 20 inch centers to secure to the hood supports (Item F). The mesh must be tight; remove one or two strands as necessary to achieve proper tension.
8. Pull the bottoms of each triangular mesh piece tight and secure with 7-inch lengths of tie wire every 8 inches to the horizontal rails.
9. Inspect for loose hardware and tighten as necessary. Also look for sharp wires and either cut or turn back into the fabric as necessary.
10. At every mating location (Elbows & Top Rail) drill through with 7/32" drill bit and hammer 1/4" x 1" drive screws into holes until seated.
11. Replace turf to cover exposed tops of footings (See Typical Footing Detail).

NOTE:

Footing: Footing sizes are based on average soil conditions. Loose and/or sandy soil is not average and footing sizes must be increased accordingly to meet local soil conditions.



 <p>Patterson-Williams ATHLETIC MFG. CO. QUALITY ATHLETIC AND PARK EQUIPMENT SINCE 1919</p>	Date: 11-06-07	SPECIFICATION/INSTALLATION INSTRUCTIONS HOODED BASEBALL BACKSTOP
	Rev: SS91517	
	Drawn: AMC	MODEL NO.
	Sheet: 3 of 4	1230-00

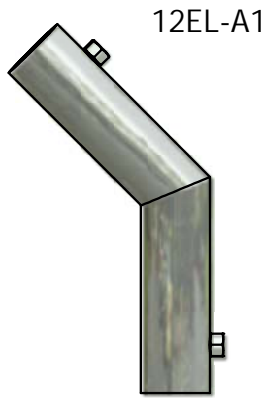

12AD-A3



12AD-A1

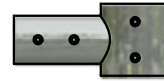

12AD-A2



ATTACHMENT
DETAIL

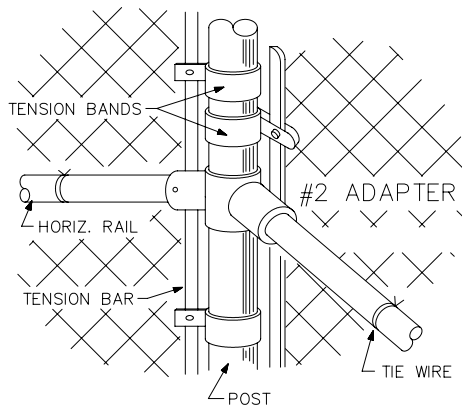

RECOMMENDED
FOOTING DETAIL

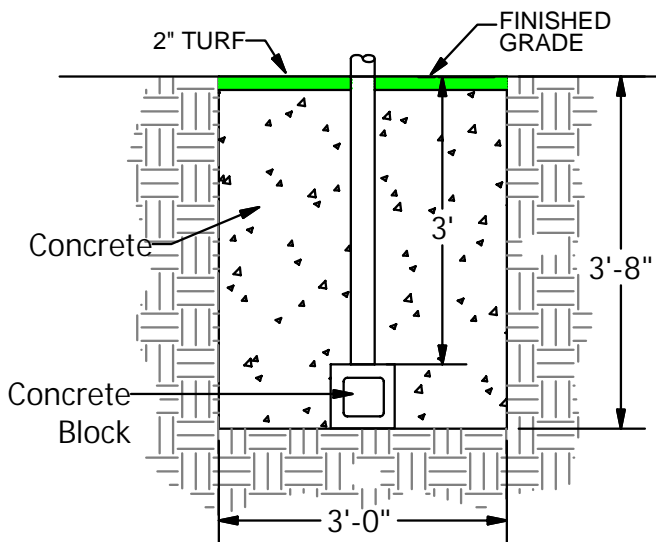

Description	Qty
Upright Post (A,B) 2-3/8" x 12' 6"	5
Hood Support (F) 2-3/8" x 9' 7"	5
Top Horiz. Rail Assembly 1-7/8" (G)	1
Horizontal Rails 1-5/8" x 9'7" (T)	10
Horizontal Rails 1-5/8" x 9'4" (U)	4
2" X 11 Gauge X 10' Wire Mesh (ft)	40
2" X 9 Gauge X 10' Wire Mesh (ft)	40
Tension Bar - 10'	14
Hardware Kit	1
INSTALLS	1
FITTING 12AD-A1 (2-7/8" O.D.)	6
FITTING 12AD-A2 (2-7/8" O.D.)	3
FITTING 12AD-A3 (2-7/8" O.D.)	4
ELBOW 12EL-A1 (2-7/8" O.D.)	5

HARDWARE KIT

Component Description	Qty
Tension Band (2-3/8")	90
Brace Band (2-7/8")	8
Brace Band (2-3/8")	20
Rail End (1-5/8")	8
5/16" x 1" Carriage Bolt	124
5/16"-18 Hex Nut	124
5/16"-18 Flat Washer	124
#10 X 1/2" Rd. Hd. Drive Screw	30
#25 drill bit	2
1/4" X 1" Rd. Hd. Drive Screw	40
7/32 Drill Bit	2
12 Gauge Tie Wire (lbs)	3
3/8"-16 x 3/8" Set Screws	60
5/8" x 3/4" Set Screws	10



Date: 11-06-07
 Rev: SS91517
 Drawn: AMC
 Sheet: 4 of 4

SPECIFICATION/INSTALLATION INSTRUCTIONS

HOODED BASEBALL BACKSTOP

MODEL NO.

1230-00



Pick Ticket

Fabrication To provide Fittings and Posts
Shipping to pull Mesh, Tension Bars, and Hardware Kit components



12AD-A3



12AD-A1

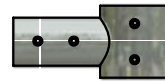

12AD-A2



HARDWARE KIT

Description	Qty
Upright Post (A,B) 2-3/8"x12' 6"	5
Hood Support (F) 2-3/8" x 9' 7"	5
Top Horiz. Rail Assembly 1-7/8" (G)	1
Horizontal Rails 1-5/8"x 9'7" (T)	10
Horizontal Rails 1-5/8"x 9'4" (U)	4
2" X 11 Gauge X 10' Wire Mesh (ft)	40
2" X 9 Gauge X 10' Wire Mesh (ft)	40
Tension Bar - 10'	14
Hardware Kit	1
INSTALLS	1
FITTING 12AD-A1 (2-7/8"O.D.)	6
FITTING 12AD-A2 (2-7/8"O.D.)	3
FITTING 12AD-A3 (2-7/8"O.D.)	4
ELBOW 12EL-A1 (2-7/8"O.D.)	5

Component Description	Qty
Tension Band (2-3/8")	90
Brace Band (2-7/8")	8
Brace Band (2-3/8")	20
Rail End (1-5/8")	8
5/16" x 1" Carriage Bolt	124
5/16"-18 Hex Nut	124
5/16"-18 Flat Washer	124
#10 X 1/2" Rd. Hd. Drive Screw	30
#25 drill bit	2
1/4" X 1" Rd. Hd. Drive Screw	40
7/32 Drill Bit	2
12 Gauge Tie Wire (lbs)	3
3/8"-16 x 3/8" Set Screws	60
5/8" x 3/4" Set Screws	10



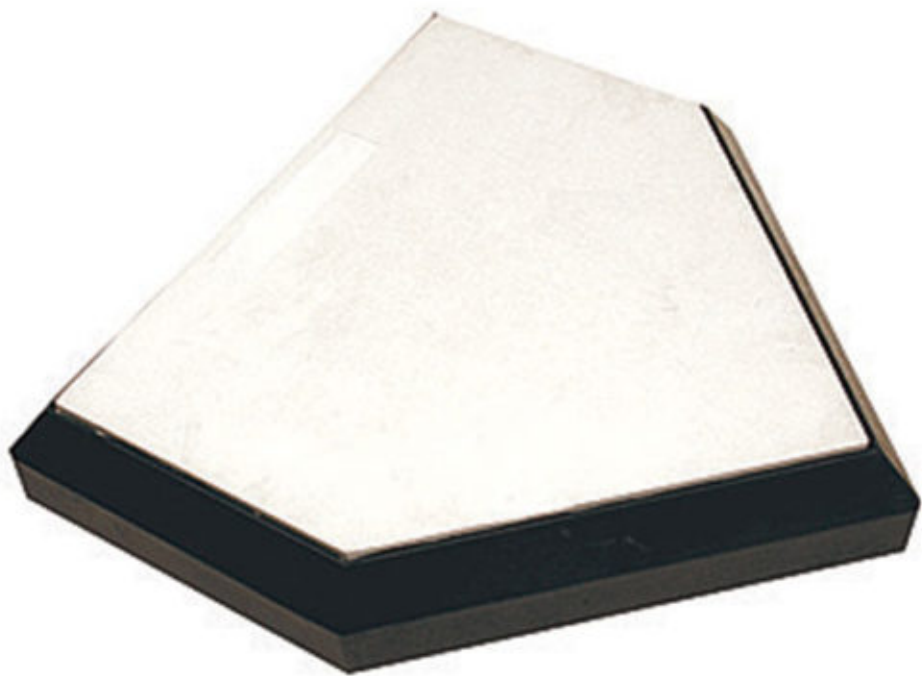

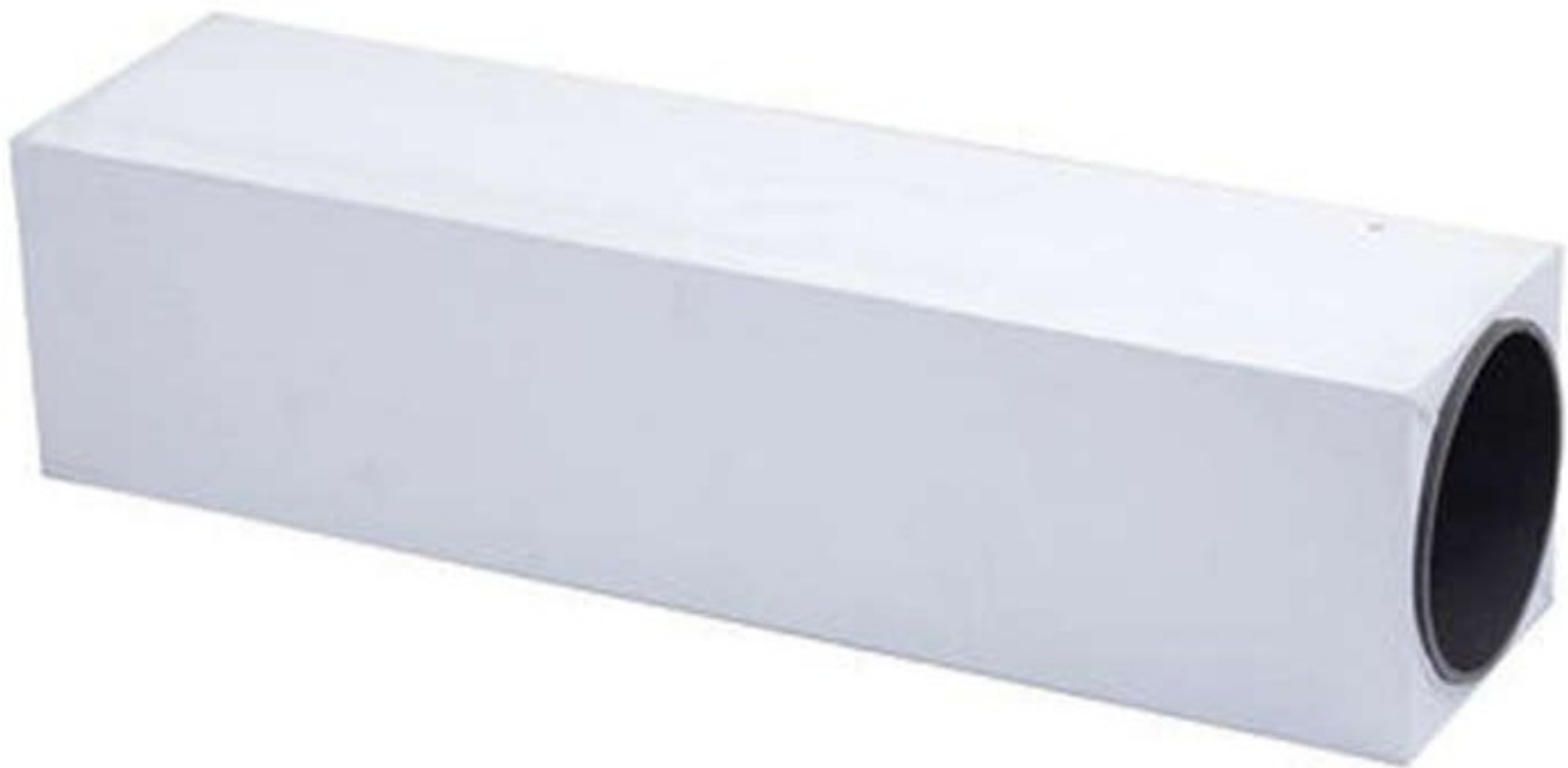





Poly-America **CONSTRUCTION SHEETING**

Poly-America's construction sheeting is made from polyethylene which provides for the optimum in economy and performance. Because of its good weatherability, chemical inertness and toughness, Poly-America's polyethylene sheeting has successfully been used for over 30 years in a wide variety of applications. Thickness ranges from as little as 0.3 mil (8 μ m) for paint drop cloths to 100 mil (2.5 mm) for use as landfill liners. Widths range up to 40 ft (12 m). If you have a special application or need more information on our products, contact your area sales representative.

Poly-America's standard sheeting will meet or exceed the following standard technical specifications:

CONSTRUCTION SHEETING

Commercial Item Description A-A-3174 Plastic Sheet, Polyolefin
Type 1
Class 1
Grade A or B
Finish 1

ASTM C171 Standard Specification for Sheet Materials Used for Curing Concrete

ASTM D2103 Specification for Polyethylene Film and Sheeting
Standard Classification 12230

Note: If requested, custom sheeting can be made to meet the following classifications:

12130 13130 13230 12330 13330

ASTM D4635 Standard Specification for Polyethylene Films Made from Low-Density Polyethylene for General Use and Packaging Applications

Type 1
 Class 2
 Surface 2
 Finish 1

ASTM D4397 Standard Specification for Polyethylene Sheeting for Construction, Industrial, and Agricultural Applications
 (see Table 1 for Impact Resistance and WVTR requirements)

TABLE 1

Thickness mils (µm)	Dart Impact ASTM D1709 g	WVTR ASTM E96 g/100 sq in-day	WVTR ASTM E96 perms	WVTR ASTM E96 metric perms
1(25)	40	1.4	.76	.50
2(51)	85	.7	.38	.25
3(76)	125	.47	.25	.17
4(102)	165	.35	.19	.12
5(127)	205	.28	.15	.10
6(152)	260	.23	.13	.084
7(178)	315	.2	.11	.070
8(203)	370	.18	.096	.063
9(229)	420	.16	.082	.054
10(254)	475	.14	.076	.050

NOTE: The above is for our standard sheeting products. Poly-America will produce custom sheeting products to meet other classifications or specifications. Contact Poly-America to see how we can help you with your needs.



LABORATORY TEST REPORT

627 Sheridan Boulevard • Lakewood, CO 80214
303.975.9959 • office@westest.net

PROJECT: Morrison Quarry
WesTest PROJECT NO.: 441515

CLIENT: Aggregate Industries
John Cheever
1705 S. Acoma Street
Denver, CO 80223

REVISED REPORT DATE: June 4, 2015
REPORT DATE: February 24, 2015
DATE SAMPLED: January 8, 2015
DATE RECEIVED: January 8, 2015
DATE TESTED: February 4-19, 2015
SAMPLED BY: Client

SOURCE: Morrison Quarry
SAMPLE DESCRIPTION: CDOT Class I Structural Fill

SAMPLE NO.: 6

GRADATION ANALYSIS - AASHTO T 11 & T 27

SIEVE SIZE	PERCENT PASSING	
	SAMPLE	SPECIFICATION
3/4"	100	100
#4	91	30 - 100
#50	37	10 - 60
#200	16.8	5 - 20

SPECIFIC GRAVITY - AASHTO T 84, ASTM C 128

BULK SPECIFIC GRAVITY	2.640
BULK SPECIFIC GRAVITY (SSD)	2.681
APPARENT SPECIFIC GRAVITY	2.752
ABSORPTION (%)	1.5

UNIT WEIGHT - ASTM C 29

METHOD OF COMPACTION	Rodding
UNIT WEIGHT (LB / FT ³)	105
VOID CONTENT (%)	36

PLASTICITY INDEX - AASHTO T 89, T 90

		SPECIFICATION
LIQUID LIMIT (%)	No Value	35 Max.
PLASTIC LIMIT (%)	No Value	
PLASTICITY INDEX	Non-Plastic	6 Max.

R - VALUE - AASHTO T 190

R - VALUE**	SPECIFICATION
79	

* Denotes deviation from specification
** Test performed by Ground Engineering

MOISTURE DENSITY RELATIONSHIP

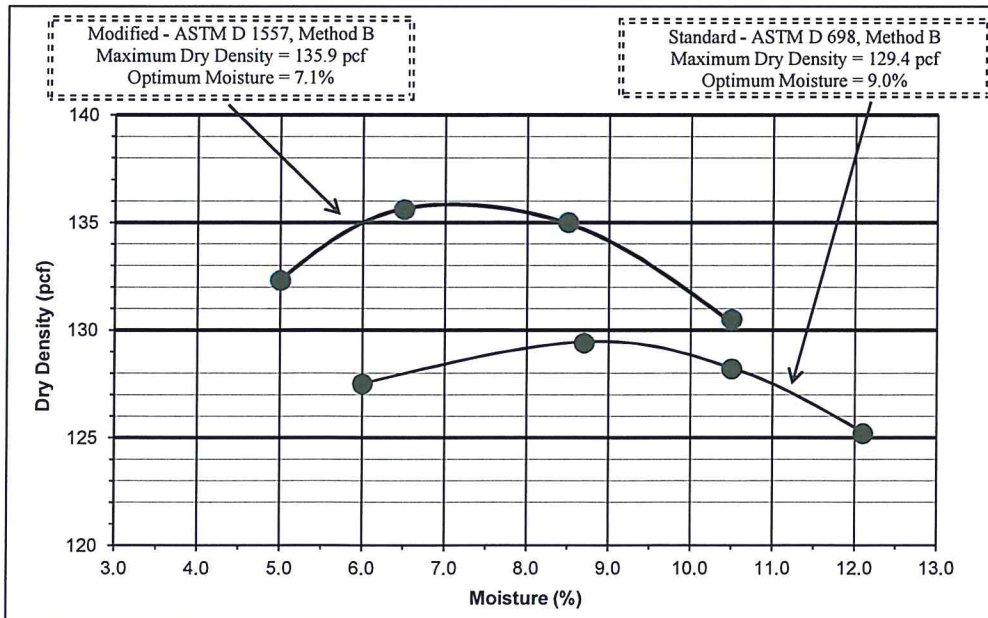

REVIEWED BY: _____

BASKETBALL BACKBOARD

MODEL #22 HEAVY DUTY CAST ALUMINUM POWDER COATED WHITE (50 LBS)

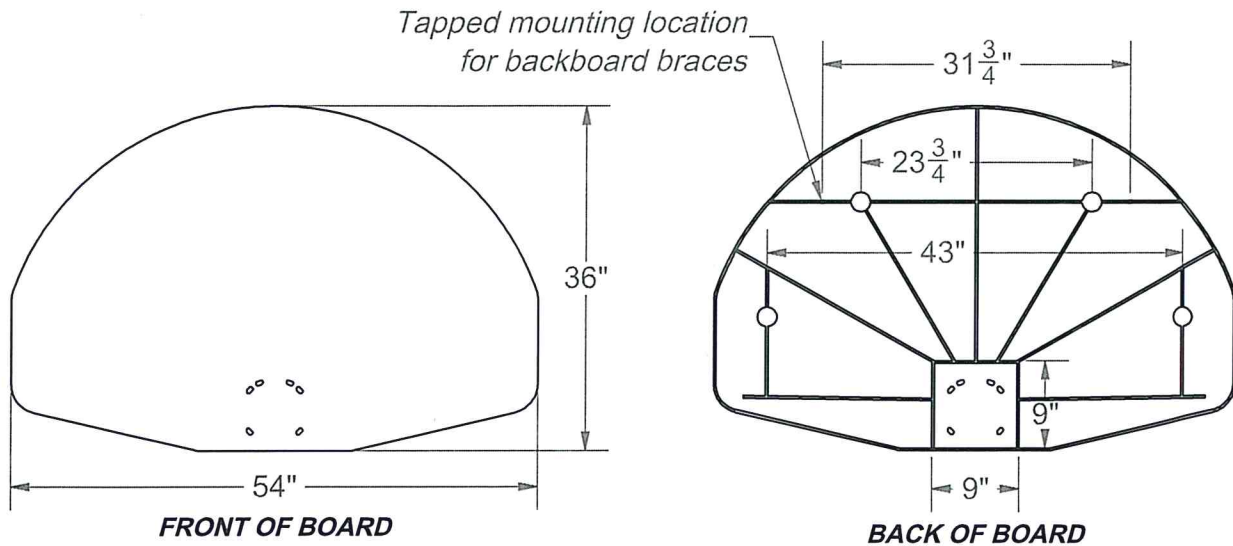

Instructions for installation of backboards to PW Athletic posts ONLY. For other manufacturer's posts and backboards, please consult installation instructions provided by that manufacturer.

MATERIALS:

Aluminum Backboard: #22 have one-piece permanent mold of 3/16" thick minimum cast aluminum alloy with 1-1/2" deep perimeter flange and reinforcing ribs. Tapped mounting holes and goal ring holes are also heavily reinforced. Edges are rounded and casting has a smooth finish. Finish is semi-gloss, powder coated white.

Warranty Period: Limited Lifetime Warranty

NOTE: Rim & Backboard to be mounted secure to sleeve adapter (GNP). Then attach sleeve to Post and secure with set screws and drive pin.

1. Align Rim with holes on Backboard & mounting plate and attach with 3/8" x 1-1/2" Hex Head bolt. Flat Washers and Nylock Nuts.
2. Attach Assembled Rim/Backboard/Sleeve to Gooseneck Post.
3. For **Adjustable Offset Goals**, attach Rim & Backboard with requested hardware to the adjustable offset. Use other half clamp and attach assembly to bottom of post. Once all hardware is snug enough, slide assembly up the post to the desired height.

CAUTION: Flat washers must be used behind plate when mounting backboard.

4. Adjust Rim/Top assembled unit to be square and tighten all bolts.

NOTE: Hardware comes separately with each item (i.e. rim, backboard, and post)

Component Description	Qty
3/8"-16 Lock Nut - Nylock	2
3/8" Flat Washer	4
3/8"-16 x 1-1/2" Flat Head Bolt	2
3/8"-16 x 3/4" Hex Bolt for Braces	2

FOR USE ON MODEL 1577:	Qty
3/8"-16 Lock Nut - Nylock	2
3/8" Flat Washer	4
3/8" - 16 x 3/4" Hex bolt for Braces	2
3/8"-16 x 2-1/2" Flat Head Bolts	2
3/4" Backboard Spacer	1



Date: 4/8/15
 Rev: SS81517
 Drawn: MT
 Sheet: 1 of 3

SPECIFICATION / INSTALLATION INSTRUCTIONS
 ALUMINUM "FAN" BASKETBALL BACKBOARD
 MODEL NO. **#22**

BASKETBALL BACKBOARD

MODEL #22 HEAVY DUTY CAST ALUMINUM POWDER COATED WHITE (50 LBS)

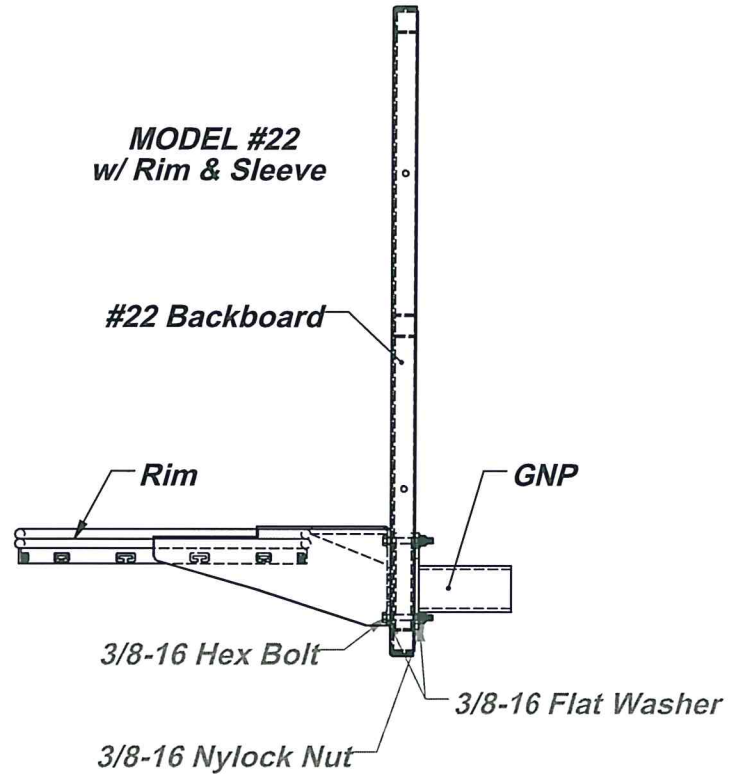
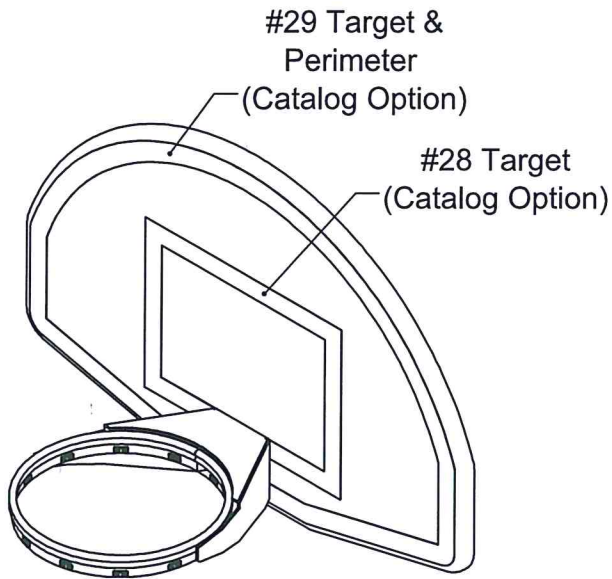

NOTE: Sleeves supplied with PW Gooseneck Post ONLY

Post Size	Sleeve Size
3.5"	3"
4.5"	4"
5.563"	5"
6.625"	6"

Universal Mounting Plate/ on 6" Sleeve

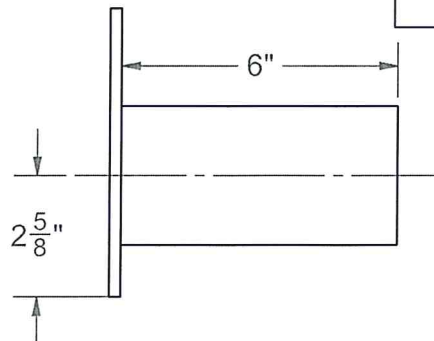
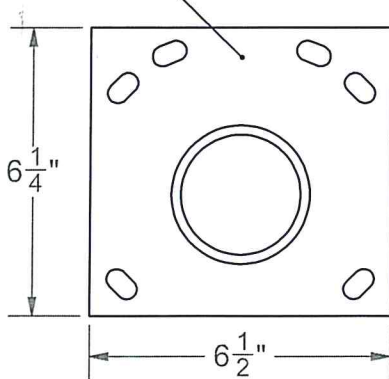

Date: 4/8/15
 Rev: SS81517
 Drawn: MT
 Sheet: 2 of 3

SPECIFICATION / INSTALLATION INSTRUCTIONS

ALUMINUM "FAN" BASKETBALL BACKBOARD

MODEL NO.

#22

BASKETBALL BACKBOARD

MODEL #22 HEAVY DUTY CAST ALUMINUM POWDER COATED WHITE (50 LBS)

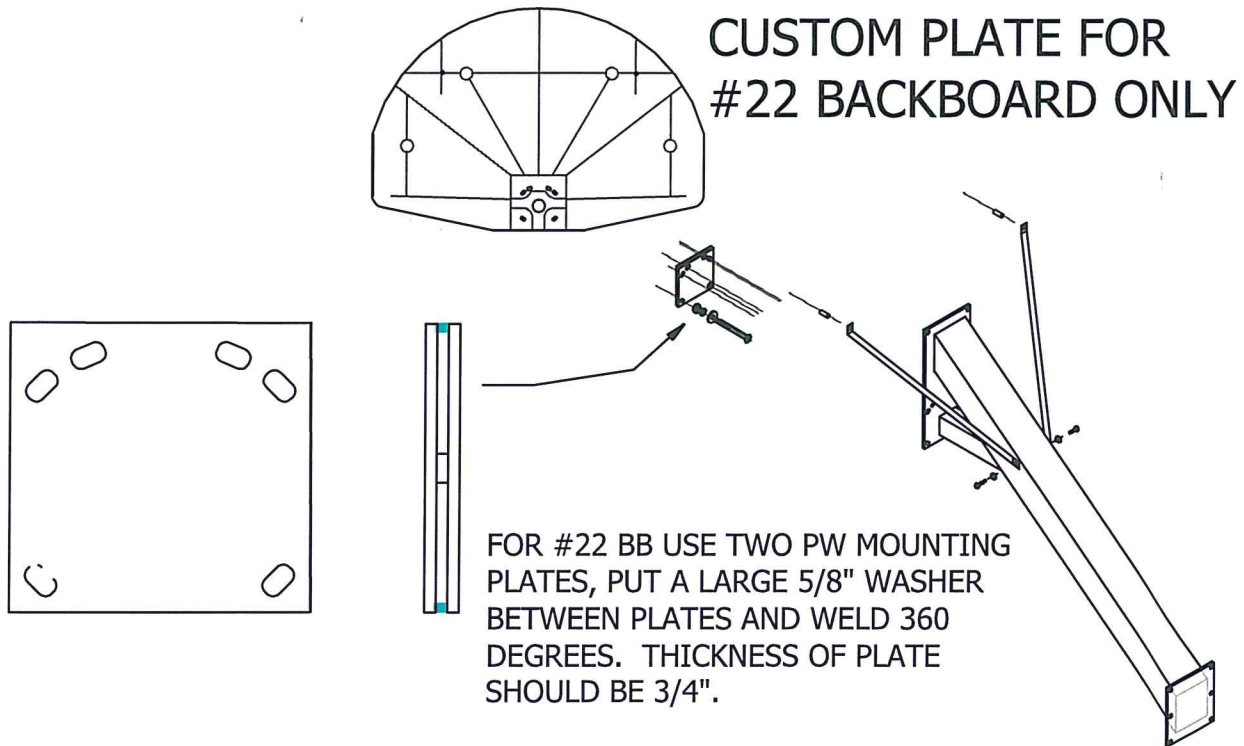

	Date: 4/8/15	SPECIFICATION / INSTALLATION INSTRUCTIONS
	Rev: SS81517	ALUMINUM "FAN" BASKETBALL BACKBOARD
	Drawn: MT	MODEL NO.
	Sheet: 3 of 3	#22

BASKETBALL GOAL RINGS & NETS

MODEL #39, 41, 44, 45 GOAL RINGS

MODEL #33, 34, 35, 36 NETS

Spec'd
Spec'd



HEAVY-DUTY
DOUBLE RIM

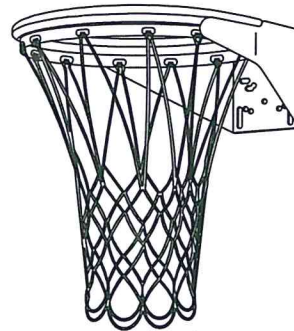

EXTRA HEAVY-DUTY
DOUBLE RIM

SPECIFICATIONS

GENERAL:

PW Athletic offers seven types of official size goal rings and a variety of nets to meet your specific requirements. See respective model numbers and descriptions below.

MATERIAL:

All materials are selected for strength, durability and the ability to withstand years of exposure.

	Date: 11-6-07	SPECIFICATION/INSTALLATION INSTRUCTIONS BASKETBALL GOAL RINGS & NETS
	Rev: SS81517	
	Drawn: AMC	MODEL NO.
	Sheet: 1 of 4	BB-GOAL RINGS & NETS

Heavy-duty double ring goal with chain net (model #44): Goal is official size 18" diameter of 5/8" round steel with an additional ring of 1/2" diameter round steel welded together. Bottom rim is formed to accommodate S-hooks to hold net. A 3/16" thick x 6-1/2" wide heavy-duty steel mounting plate is welded to the goal rings. The mount plate is drilled with a 6-hole universal mounting pattern. Goal is finished with an orange powder coated color. Goal ring is not designed for use with nylon or other fabric-type nets.

Heavy-duty double ring goal with super nylon net (model #45): Goal is fabricated with two 18" diameter steel rings 5/8" diameter are welded together, with 1/8" diameter steel formed with 12 pigtail style net hooks welded to the bottom of the ring. A 3/16" thick x 6-1/2" wide heavy-duty steel mounting plate is welded to the goal ring which is further reinforced with a 1/2" diameter round steel support welded between each side of ring and the angle bracket. The mounting plate is drilled with a 6-hole universal mounting pattern. Goal is finished with an orange powder coated color.

Extra Heavy-duty double ring goal (model #39): Goal is official size 18" diameter round steel rim welded together. A 3/16" thick steel mounting plate is welded to the goal ring and comes drilled with a 6-hole universal mounting pattern. The rim support is welded between bottom and top rim. Net lock design is for chain and/or nylon nets. Goal is finished with an orange powder coated color.

Breakaway heavy-duty double ring goal with super nylon net (model #41): Goal is official size 18" diameter of double 5/8" diameter round steel rims welded together. A 3/16" thick steel net support welded to a 3/16" steel box shaped mounting plate swivel mounted by 1/2" diameter pin to house dual spring mechanism. Net lock design is for chain and nylon nets. Goal is finished with an orange powder coated color.

Component Description	Qty
For Boards - 13, 14, 25, and 26	
3/8"-16 X 1-1/4" Hex Bolt	4
3/8"-16 Lock Nut - Nylock	4
3/8" Flat Washer	8
For Boards - 19, 22, 23 & 24	
3/8"-16 X 2" Hex Bolt	4
3/8"-16 Lock Nut - Nylock	4
3/8" Flat Washer	8
For Boards - 18 & 20	
3/8"-16 X 2 1/2" Hex Bolt	4
3/8"-16 Lock Nut - Nylock	4
3/8" Flat Washer	8
For Boards - 10	
3/8"-16 X 3" Hex Bolt	4
3/8"-16 Lock Nut - Nylock	4
3/8" Flat Washer	8
For Boards - 27	
3/8"-16 X 3-1/2" Hex Bolt	4
3/8"-16 Lock Nut - Nylock	4
3/8" Flat Washer	8
NOTE: FOR RIM #31 & 38 WITH STD CHAIN NET ADD S-HOOKS	12



Date:	11-6-07
Rev:	SS81517
Drawn:	AMC
Sheet:	2 of 4

SPECIFICATION/INSTALLATION INSTRUCTIONS
BASKETBALL GOAL RINGS & NETS
MODEL NO.
BB-GOAL RINGS & NETS

Replacement Chain Net, model #33: Zinc plated steel chain net with S-hooks to secure all goals.

Replacement Super Nylon Net, model #34: Extra heavy braided nylon net to reduce net whip.

Replacement Super Chain Net, model #35: Zinc plated steel chain net with all loops welded closed to prevent snagging or opening.

Note: For net attachment see following page.

Goal Warranty Period: Limited Lifetime

For #33 & #35 chain nets slip s-hooks through holes on the goal rings (Models #37, #38, #44 & #31) and fully close.

For #34 Super Nylon Net on goal ring Models #39 & #41 twist loop on net. From the inside of the rim, slip the twisted loop through the punched net tie-off hole to the outside of the rim. Wrap twisted loop around goal ring and back through punched net tie-off ring. Secure around neck of the punched tie-off hole and pull tight.

For #34 Super Nylon Net on goal ring Model #45 slip the net loop through from the inside through the welded net tie-off wire and hook onto middle of tie-off wire and pull tight.

Model#	Description	Net Type	Wt#
39	Extra Heavy-Duty Double Rim	Super Nylon	28 lbs.
41	Breakaway Extra Heavy-Duty Double Rim	Super Nylon	29 lbs.
44	Heavy-Duty Double Rim	Super Chain	19 lbs.
45	Heavy-Duty Double Rim	Super Nylon	18 lbs.

For installation of goal rings to PW Athletic backboards and posts ONLY. For other manufacturer's posts and backboards please consult installation instructions provided by that manufacturer.

Caution: Flat washers must be used behind plate when mounting backboard.

Align mounting holes in goal ring mounting plate with the corresponding holes in the backboard and gooseneck adaptor mount using installation hardware (bolts). Install lock nuts and tighten enough to hold board and goal ring in position.

Plumb backboard true vertical (shim if necessary) and goal ring level. Tighten all hardware securely. Install net. If the goal ring is equipped with chain net, make sure all S-hooks are fully closed

	Date: 11-6-07	SPECIFICATION/INSTALLATION INSTRUCTIONS BASKETBALL GOAL RINGS & NETS
	Rev: SS81517	
	Drawn: AMC	MODEL NO.
	Sheet: 3 of 4	BB-GOAL RINGS & NETS

NETTING OPTIONS

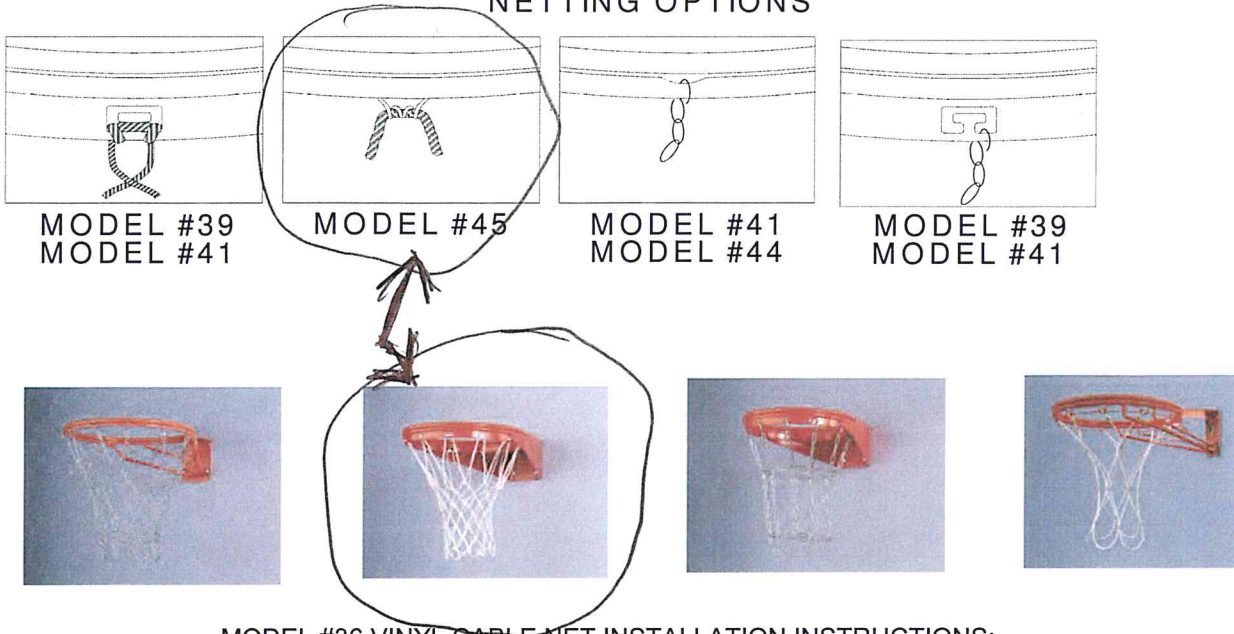

MODEL #36 VINYL CABLE NET INSTALLATION INSTRUCTIONS:

1) Starting at the back of the rim, thread the orange rimlock cable through one side of a net connector (Fig. 1a), then through the eyelet of the net (Fig. 1b) & finally through the other end of the net connector (Fig. 1c). Pull the cable firmly forcing the net eyelet up into the middle of the net connector (Fig. 1d). Leave approximately 4" of cable behind this first net connector to allow for connection with the other end of the cable at the end of the threading process. Repeat the threading process through the remaining q1 connection points on the rim, pulling all slack from the cable as you go. (Note: The net eyelet must be centered in the net connector to prevent sideways movement of the net around the rim)

2) When all of the eyelets are threaded, the two ends of the rimlock cable must be secured together. Ensure that there is no slack in the cable at any point. Thread the two cable ends into opposing sides of the supplied aluminum sleeve (Fig. 2a). Using a large pair of pliers, crimp the sleeve flat at both ends against the rimlock cable (Fig. 2b). This must be crimped well to prevent the cable from slipping.

3) Due to it's unique construction, it is very important to stretch the net in the middle and bottom sections to prevent the ball from sticking (Fig. 3a & 3b). Grab opposing sides and pull hard. Repeat this stretching technique all the way around the middle and bottom of net. Cold weather may require re-stretching.

THESE STYLE OF RIMS USE THE FOLLOWING METHOD:

The orange rimlock cable will travel around the outside of the rim and weave in and back out of each rim connector. Feed the cable from the outside of the rim in, threading it through one net eyelet. (Leave 4" of cable tail from your starting point) Continue threading the cable back from the inside to the outside of the rim using the same connector. Pull tight all slack in the cable as you go. This will force the net eyelet close to the given rim connector. Repeat for all 11 remaining connections and terminate the cable with the supplied sleeve as in step above.

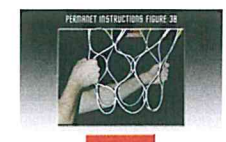
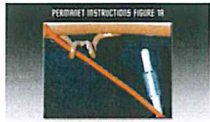
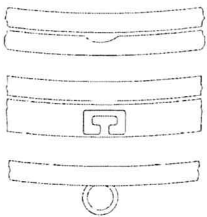

Date:	11-6-07
Rev:	SS81517
Drawn:	AMC
Sheet:	4 of 4

SPECIFICATION/INSTALLATION INSTRUCTIONS

BASKETBALL GOAL RINGS & NETS

MODEL NO.

BB-GOAL RINGS & NETS

SINGLE BASKETBALL POST

MODEL #1523 4-1/2" O.D. WITH 4' OFFSET (185 LBS)

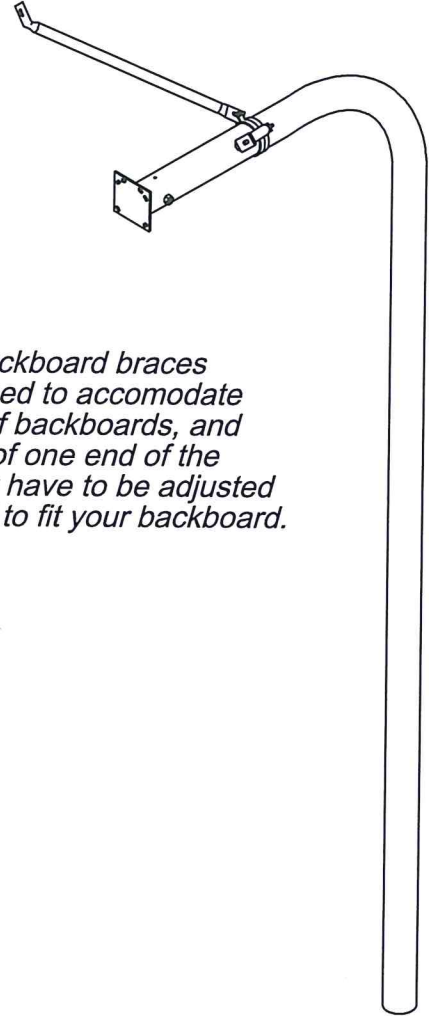
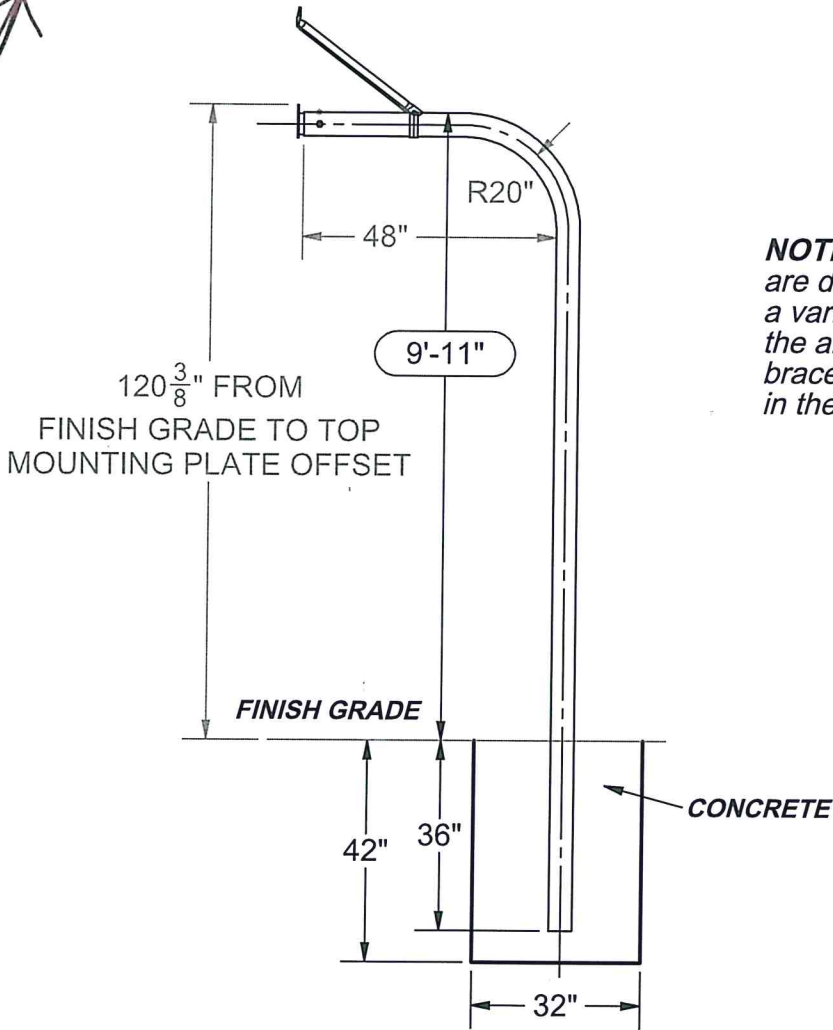
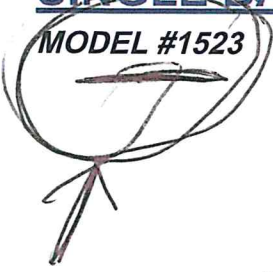

NOTE: Backboard braces are designed to accommodate a variety of backboards, and the angle of one end of the brace may have to be adjusted in the field to fit your backboard.

SPECIFICATIONS:

Material: Support post is a single length of 4-1/2" O.D. galvanized steel formed to provide a graceful 4 ft offset. Backboard mount is a 6-1/4" x 6-1/2" steel plate welded to the sleeve adapter then mounted to support post with set screw & drive pin.

A pair of diagonal braces, 1-3/8" O.D. galvanized steel, is mounted between the backboard and the post. Braces bolt to the backboard and are secured to the post with a pair of steel clamps formed to fit the post diameter.

All welds are either treated with cold-galvanizing compound or prepared for powder coating, depending on finish selected. All hardware is zinc-plated for long rust-free service.

 <p>ATHLETIC MFG. CO.</p>	Date: 3/19/2007	SPECIFICATION / INSTALLATION INSTRUCTIONS
	Rev: SS81817	<i>SINGLE POST GOOSENECK</i>
	Drawn: MT	MODEL NO.
	Sheet: 1 of 2	1523

PERMANENT FOOTING DETAIL

NOTE: Footing sizes are based on average soil conditions. Loose and/or sandy soil is not average and footing sizes must be increased accordingly to meet soil conditions and local building codes and specifications. Post depth is approximate, and should be adjusted to ensure that the top of the Gooseneck offset post is 9'-11" above finish grade.

INSTALLATION INSTRUCTIONS:

1. Dig a hole in desired location per footing chart dimensions. Set the bottom of the post in center of the hole and shim from below or fill such that the top of the Gooseneck Post on the offset is (9' 11") above finish grade. Plumb post true vertical and brace. NOTE: Top of rim will be at 10' when installed.

NOTE: Verify that the backboard mounting plate is perpendicular to the surface by using a level (vertical) before pouring concrete.

2. Pour concrete and allow the concrete to set for 3 days before removal of bracing and completion of installation. Cover footings with turf or court materials.
3. Attach diagonal braces with the brace bands and carriage bolts provided. Slip both brace bands onto post and attach with carriage bolts.
4. *Refer to backboard installation instructions to complete backboard & GNP Adapter installation.*
5. Slide brace bands and braces toward the back of the backboard until the opposite end of the diagonal brace aligns with attachment angles or nuts. NOTE: Attach the diagonal braces either to welded nuts or attachment angles, depending on backboard.
6. Tighten all bolts.
7. Once everything is tightened drill 1/4" Drive Pin holes in the GNP Adapter through the Gooseneck holes on top & bottom of offset end with the undersized (7/32" Drill Bit).

Packing Slip	Qty
4-1/2" O.D. Gooseneck Post 4' Offset	1
4" GNP Adapter	1
35" Diag. Brace	1
36" Diag. Brace	1
4-1/2" O.D. Brace Band	2
Hardware Kit	Qty
5/16"-18 x 1-1/4" Carriage Bolt	2
5/16"-18 Nylock Nut	2
5/8" Set Screw	1
1/4" SS Drive Pin	2
5/16" Hex Key Wrench	1

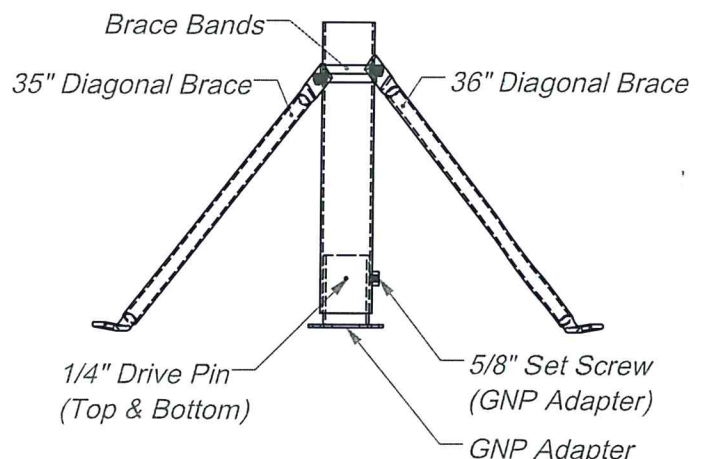

	Date: 4/9/16	SPECIFICATION / INSTALLATION INSTRUCTIONS
	Rev: SS81817	
	Drawn: MT	<i>SINGLE POST GOOSENECK</i>
	Sheet: 2 of 2	MODEL NO. 1523



Concrete Mix Design: A4566

Description: 4,000 PSI Air Entrained, 15% Class C Fly Ash, General Exterior

MM Lab No.: A4566

CONCRETE MIX PROPORTIONS:

	ASTM	Varies	Cubic Yard	Units	
Cement	C-150		479	lbs	
Fly Ash	C-618		85	lbs	
Sand	C-33		1325	lbs	
#57/67 Agg.	C-33		1820	lbs	
AEA	C-260	0 to 8 oz/cy	3.6	oz	
MRWR	C-494	0 to 8 oz/cwt	33.8	oz	
Hyd Stab.	C-494	0 to 9 oz/cwt	0.0	oz	
Water	C-94		265.0	lbs	31.81 Gal.

The above weights are based upon aggregates being in the saturated, surface dry condition. Batch plant corrections must be made for aggregates that vary from these moisture conditions. ** AEA adjustments at plant and on site may be required to achieve proper air entrainment. Air adjustments may be made with either liquid or Fritz air entrainment. Mix proportions may be adjusted in accordance with ACI 301 sections 3.8, 3.11 and 17.2.

PHYSICAL PROPERTIES OF MIX:

TARGET:

Slump	3.00-5.00"
Air Content	4.5-7.5%
Unit Weight	147.2
Water/Cement Ratio	0.47 Max
Yield	27.0

COMPRESSIVE STRENGTH (psi):

(From available field data.)

7 Day

4100

28 Day

5360

STRENGTH PERFORMANCE REPORT

Mix Design: A4566
 Batch Date Range: 24 Aug 2018 to 21 Nov 2018

Specified Strength: 4000 psi
 Required Strength: 4640 psi

	Air	Slump/Flow	3 Day	7 Day	28 Day	56 Day
Count:	30	30		29	30	
Lot Average:	6.3	4.78		4100	5360	
Minimum Value:	4.0	3.00		3310	4550	
Maximum Value:	8.0	8.25		5140	6280	
Standard Deviation:	1.0	1.26		485	480	

Sample		Air	Slump/Flow	3 Day	7 Day	28 Day	56 Day
Ticket #	Date Sampled	%	(in)	(psi)	(psi)	(psi)	(psi)
21062621	24 Aug 2018	5.0	3.25		4520	5620	
37176684	29 Aug 2018	5.0	5.00		3950	5280	
45083017	30 Aug 2018	5.0	5.00		3800	5400	
46340784	30 Aug 2018	7.0	4.75		4000	5240	
21062944	31 Aug 2018	5.4	4.25		4290	5720	
35065083	31 Aug 2018	7.6	5.25		4740	6280	
45083116	04 Sep 2018	6.7	4.00		4070	5610	
21063098	07 Sep 2018	6.8	4.50		4620	5960	
47073139	10 Sep 2018	6.0	6.00		3320	5280	
43209352	14 Sep 2018	6.4	4.25		4390	5900	
45083557	17 Sep 2018	5.9	4.50		4650	4800	
45083677	20 Sep 2018	5.1	3.00		3780	4890	
21064002	25 Sep 2018	7.5	7.00		3850	4820	
45083862	25 Sep 2018	6.0	4.00		3730	4700	
46048165	25 Sep 2018	7.0	5.25			5240	
22045430	26 Sep 2018	8.0	7.00		3310	4780	
20093578	27 Sep 2018	5.4	3.25		4730	5980	
43211316	29 Sep 2018	6.2	5.00		3940	5010	
45084204	02 Oct 2018	6.9	3.00		4350	5810	
45084284	04 Oct 2018	7.2	4.00		3610	4860	
20094072	05 Oct 2018	6.5	4.00		3620	4900	
45084490	12 Oct 2018	7.0	4.00		3540	4550	
20094499	16 Oct 2018	6.9	7.00		3440	5560	
43213239	18 Oct 2018	5.0	4.00		4350	6020	
43213529	22 Oct 2018	7.2	5.00		3820	5630	
21066196	06 Nov 2018	6.7	4.50		4560	5540	
21066365	08 Nov 2018	7.0	5.50		4120	5040	
20095996	10 Nov 2018	7.2	5.00		3860	4720	
20096471	21 Nov 2018	4.5	3.75		5140	5610	
46049532	21 Nov 2018	4.0	8.25		4800	5920	

Fence Fittings

ASTM F 626-08, Federal specification RR-F-191, AASHTO M-181

1. PRODUCT NAME

Fence Fittings, Chain Link

2. MANUFACTURER

Merchants Metals

Corporate Headquarters:

900 Ashwood Parkway, Suite 600

Atlanta, GA 30338

Phone: (866) 888-5611

Merchants Metals Service Centers are located throughout the United States.

3. PRODUCT DESCRIPTION

Basic Use:

Fence fittings include those items that are routinely used in conjunction with metallic coated chain link fabric and framework to complete a chain link fence installation.

Composition and Materials:

Fence fittings for chain link fence may be manufactured from steel or aluminum alloy. Steel items are galvanized after fabrication.

Standards:

- ASTM A641/A641M Specification for Zinc-Coated (Galvanized) Carbon Steel Wire
- ASTM A809 Specification for Aluminum-Coated (Aluminized) Carbon Steel Wire
- ASTM A817 Specification for Metallic-Coated Steel Wire for Chain-Link Fence Fabric and Marcellled Tension Wire
- ASTM B26/B26M Specification for Aluminum-Alloy Sand Castings
- ASTM B85 Specification for Aluminum-Alloy Die Castings
- ASTM B108 Specification for Aluminum-Alloy Permanent Mold Castings
- ASTM B117 Practice for Operating Salt Spray (Fog) Apparatus
- ASTM B209 Specification for Aluminum and Aluminum-Alloy Sheet and Plate
- ASTM B209M Specification for Aluminum and Aluminum-Alloy Sheet and Plate (Metric)
- ASTM B211 Specification for Aluminum and Aluminum-Alloy Rolled or Cold Finished Bar, Rod, and Wire
- ASTM B211M Specification for Aluminum and Aluminum-Alloy Rolled or Cold-Finished Bar, Rod, and Wire (Metric)
- ASTM B221 Specification for Aluminum and Aluminum-Alloy Extruded Bars, Rods, Wire, Profiles, and Tubes
- ASTM B221M Specification for Aluminum and Aluminum-Alloy Extruded Bars, Rods, Wire, Profiles, and Tubes (Metric)
- ASTM B429/B429M Specification for Aluminum-Alloy Extruded Structural Pipe and Tube

ASTM F552 Terminology Relating to Chain Link Fencing

ASTM F626 Standard Specification for Fence Fittings

ASTM F668 Specification for Polyvinyl Chloride (PVC), Polyolefin and Other Polymer-Coated Steel Chain Link Fence Fabric

ASTM A817 Specification for Metallic-Coated Steel Wire for Chain-Link Fence Fabric and Marcellled Tension Wire

ASTM F934 Specification for Colors for Polymer-Coated Chain Link Fence Materials

Federal specification RR-F-191 American Association of State Highway Transportation Officials M-181 Chain Link Fence

4. TECHNICAL DATA

General:

The manufacturer, if requested, will supply samples and certification that all materials comply with the appropriate specifications.

Post and Line Caps:

Post and line caps are fabricated from pressed steel or cast iron and hot-dip galvanized with a minimum of 1.2oz/ft² (366 g/m²) of zinc coating of surface area, or from aluminum alloy 380.0 conforming to die cast Specification ASTM B85, or sand cast or permanent mold alloy 356.0 or 713.0 conforming to Specification ASTM B26/B26M or ASTM B108.

Rail and Brace Ends:

Rail and brace ends are fabricated from pressed steel or cast iron and galvanized with a minimum of 1.2 oz/ft² (366 g/m²) of zinc, or aluminum alloy 6063-T6 (ASTM B221 or B429). The thickness is 0.051 in. (1.3 mm) of steel or 0.062 in. (1.8 mm), of aluminum alloy, minimum length is 6 in. (152 mm).

Top Rail Sleeves:

Top rail sleeves shall be fabricated from pressed steel or round steel tubing and hot-dip galvanized with a minimum of 1.2oz /ft² (366 g/m²) of zinc coating surface area, or from aluminum alloy 6063-T6 (see Specification B221, B221m or Specification B429/B429M). Rail sleeve material shall be a minimum of 0.051 in. (1.3 mm) in thickness if steel, or a minimum of 0.062 in. (1.8mm) in thickness if aluminum alloy, and a minimum of 6 in. (152.4 mm) in length.

Tie Wires and Hog Rings:

Tie Wire used to tie fabric to frame work and Hog rings for attaching fabric to tension. Fabricated from steel wire galvanized minimum zinc coating 1.2oz/ft² (366 g/m²) 9 gauge (0.148) (3.76 mm) steel wire - lighter gauge steel wire may be used on lighter gauge mesh, see ASTM F626.

Tension and Brace Bands:

Tension and brace bands are fabricated from pressed steel or cast iron and galvanized with a minimum of 1.2 oz/ft² (366 g/m²) of zinc, or aluminum alloy 6063-T5, 6063-T6, or 8176-H19 (ASTM B211 or B221). Tension bands have a minimum material thickness of 14 ga. (0.074 in. (1.88 mm) and a minimum width of ¾ in. (19 mm). Brace bands have a minimum material thickness of 12 ga. (0.105 in. 2.66 mm) and a minimum width of ¾ in. (19 mm).

Tension bars:

Steel tension bars are fabricated from merchant quality steel and galvanized, minimum zinc coating weight 1.2oz/ft² (366 g/m²). Steel tension bars used to connect 1-3/4 in. (44 mm) and 2 in. (50 mm) mesh fabric to end, gate and corner posts are a minimum 3/16 in. (4.8 mm) by 5/8 in. (16 mm) for fabric heights to 5 ft. (1,520 mm) and 3/16 in. (16 mm) by 3/4 in. (19 mm) for fabric heights over 5 ft. (1,520 mm). Tension bars used to connect 1 in. mesh fabric to end; gate and corner posts are a minimum 1/4 in. (6 mm) by 3/8 in. (10 mm). The minimum length of a tension bar is 2 in. (50 mm) less than the full height of the chain link fabric.

Truss Rod and Tightener:

Steel truss rods shall be fabricated from 3/8 in. (9.5mm) merchant quality rod and it and all related devices shall be hot-dip galvanized after threading with a minimum of 1.2oz/ft² (366 g/m²) of zinc coating and shall withstand 2000lb (900 kg) of tension.

Barbed Wire Arms:

Barbed wire arms shall be fabricated from pressed steel or cast iron, and hot-dip galvanized with a minimum 1.2 oz/ft² (366 g/m²) of zinc coating. Barbed wire arms are available as various types.

Tension Wire:

Tension wire per ASTM A817 Specification for Metallic-Coated Steel Wire for Chain-Link Fence Fabric and Marcellled Tension Wire, shall be 7 gauge (0.177 + 0.005 in. (4.50 + 0.13 mm) is either zinc or aluminum coated:

Type I - Aluminum-coated (aluminized), minimum average coating weight 0.40oz/ft² (122 g/m²).

Type II - Zinc-coated (galvanized), Class 4, minimum average coating weight 1.2oz/ft² (366 g/m²).

Minimum breaking strength is 1,950 lbf [8,670 N].



Merchants Metals[®]

the first name in fence solutions

Revised: April 2014

Fence Fittings

ASTM F 626, Federal specification RR-F-191, AASHTO M-181

COLOR COATING OF FITTINGS:

Fittings may be color coated with a polymer to match the fabric, when so specified. Standard colors are as contained in ASTM F934. Painted fittings are not acceptable. The exterior surface of the fittings shall be polymer coated with a minimum 0.006-in (0.152-mm), maximum 0.015-in (0.381-mm) thickness when so specified. Ferrous fittings shall be hot-dip galvanized prior to application of color coating

5. AVAILABILITY AND COST

Availability:

Chain link fittings are available for shipment throughout the United States and worldwide.

Cost:

Costs may vary with specific project requirements. Costs may be obtained through all Merchants Metals Service Centers.

6. MAINTENANCE

Periodic inspection is recommended but no routine maintenance is required.

7. TECHNICAL SERVICES

Specifications, drawings, and other technical services are available through the Merchants Metals Technical Sales Department or your local Merchants Metals Service Center.

Technical Services:

Phone: (888) 260-1600 (toll free)

Fax: (888) 261-3600 (toll free)

E-Mail: Tech-Info@merchantsmetals.com

Website: www.merchantsmetals.com

Representative Illustrations of Common Chain Link Fence Fittings (not to scale)

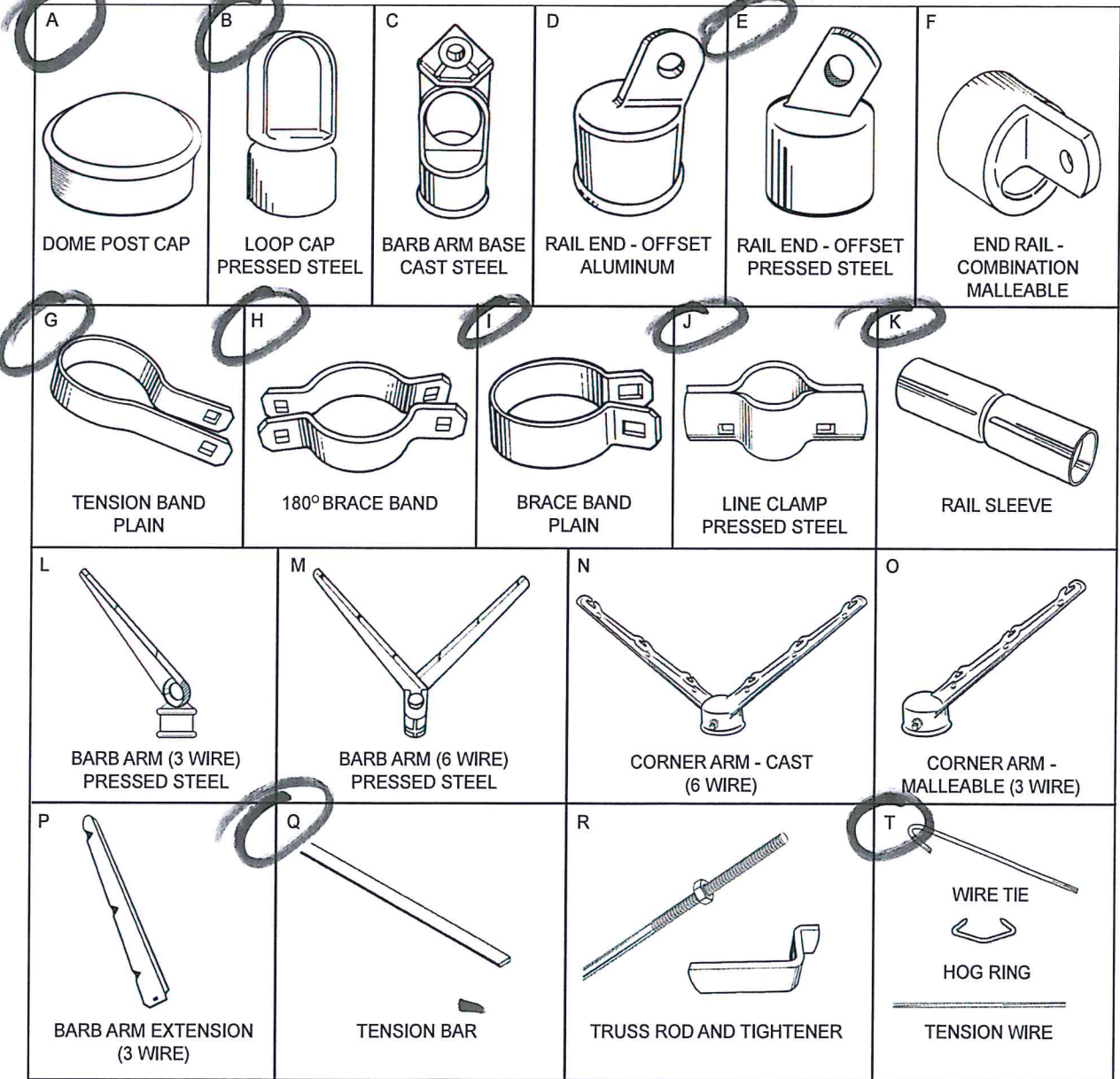

Technical Sales Department:
Telephone: (888) 260-1600 Fax: (888) 261-3600
E-mail: Tech-Info@merchantsmetals.com
Website: www.merchantsmetals.com

High-security, Security and Industrial Fence Framework

Schedule 40 per ASTM F1083, WT-40 per ASTM F1043

Applications— Prisons, military and secure government facilities, highways, bridge fencing, utility and water treatment plants, schools, public play and ball fields, border fence, chemical plants, sea ports, airports, framework and supports for solar panels— basically unlimited applications.

Schedule 40 per ASTM F1083

Wheatland F1083 is the original specified fence framework used for commercial, industrial and high-security applications. Wheatland is the leading supplier of ASTM F1083 full-weight Schedule 40 domestic fence framework. Wheatland manufactures all F1083 grades; Regular Grade 30,000 psi, High Strength 50,000 psi and Schedule 80. When the specification requires Schedule 40 pipe, Wheatland's F1083 is the clear choice. Our ISO 9001 certified CW facility produces the finest Schedule 40 products in the world and is supported by over 130 years of experience delivering prompt, knowledgeable and personalized service.

- Meets or exceeds the requirements of ASTM F1083
- Meets or exceeds the requirements of ASTM F1043, Group 1A
- Full-weight Schedule 40 wall thickness
- Pure zinc hot-dip galvanized 1.8 oz./ft² outside, and 1.8 oz./ft² inside (2.0 oz./ft² available)
- Conversion coating inside and outside for additional protection
- The only Schedule 40 pipe coated with virtually lead-free galvanizing
- Most extensive size range of any fence framework product, 1 $\frac{3}{8}$ "-8 $\frac{3}{8}$ " OD

Certification

Wheatland Tube will certify that all Wheatland F1083 fence pipe is manufactured in the USA and is in compliance with applicable local, state and federal specifications. "WHEATLAND USA ASTM F1083" is proudly displayed on each length of F1083 pipe.

Specifying Agencies

- American Association of State Highway and Transportation Officials (AASHTO) M181—Grade 1
- Federal specifications RR-F-191/2E and RR-F-191/3E
- U.S. Army Corps of Engineers UFGS-32 31 13
- Department of the Navy
- Department of Transportation
- Federal Aviation Administration AC 150/5370-10 Item 162
- U.S. Department of Justice—Federal Bureau of Prisons
- ASTM Specification F1043, Group 1A, Standard Specification for Strength and Protective Coatings
- American Institute of Architects (AIA) MasterSpec®
- ASTM Specification F1083

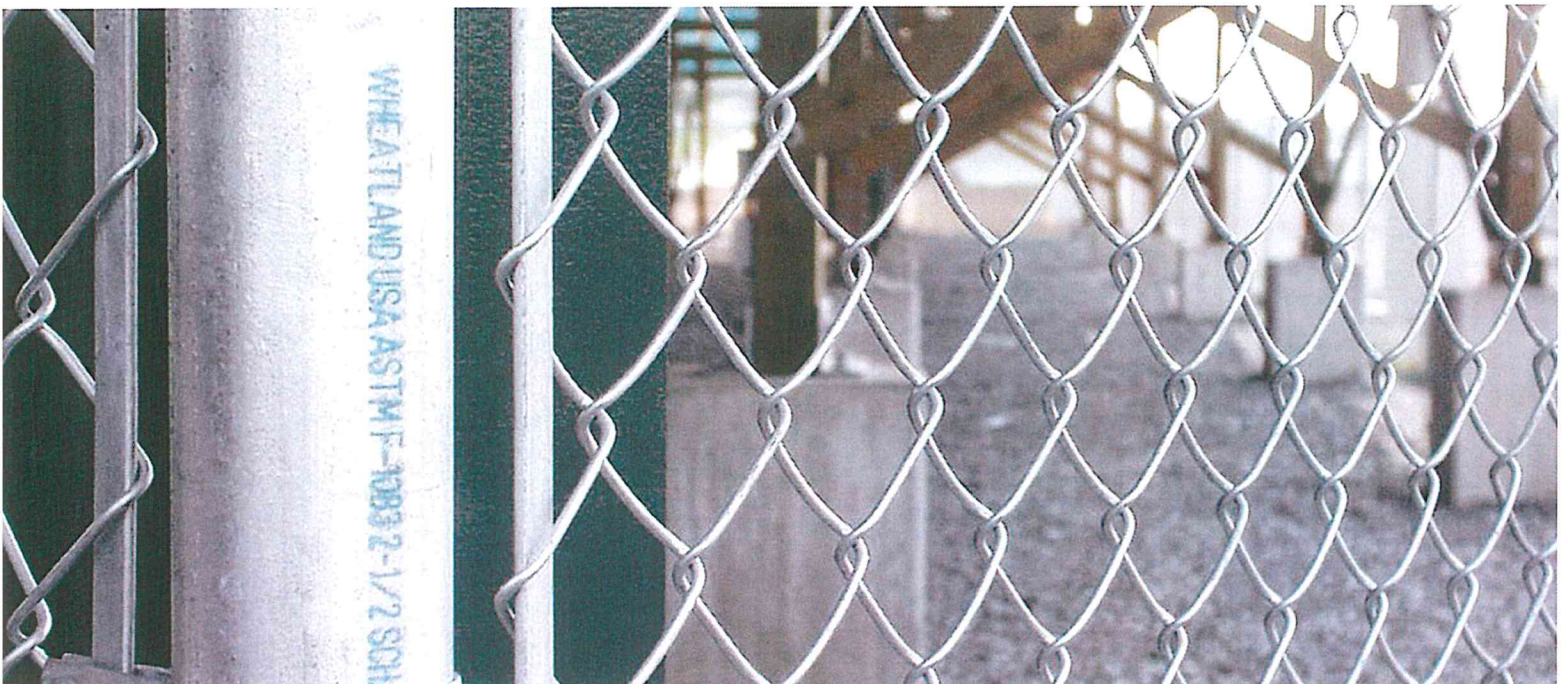

WT-40 per ASTM F1043, Group 1C

Wheatland Tube will certify that all Wheatland WT-40 pipe is manufactured in the USA and is in compliance with applicable local, state and federal specifications. "WT-40 MADE IN USA" is proudly displayed on each length of WT-40 pipe.

High-strength Spec Fence Framework

The strength and corrosion characteristics of Wheatland WT-40 fence pipe have been tested, documented and certified by independent testing agencies to ensure complete compliance with ASTM F1043, Group 1C, and AASHTO M181. Wheatland WT-40 fence framework meets or exceeds the most demanding specifications and codes imposed by private, independent and government agencies.

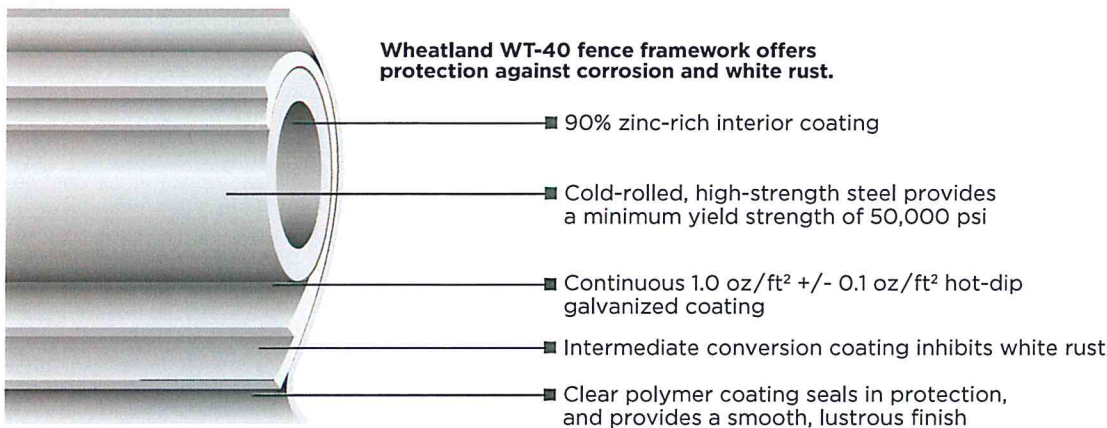

Materials

- 1. Steel**— Steel strip used in the manufacture of Wheatland WT-40 fence pipe shall conform to ASTM A1011 and will meet or exceed all performance criteria set forth in this standard specification.
- 2. Zinc**— Zinc used in Wheatland WT-40 fence pipe shall conform to ASTM B6. Galvanizing shall be continuous hot-dipped on OD.
- 3. Conversion Coating**— An intermediate conversion coating shall be applied in-line over the continuous hot-dip galvanizing coating to inhibit white rust and enhance corrosion resistance.
- 4. Clear Polymer Coating**— A clear polymer coating shall be applied over the intermediate conversion coating. This polymer coating provides a smooth, lustrous protective finish.
- 5. Heat-set Internal Coating**— A heat-set zinc-rich ID coating shall have a minimum zinc loading of 90%.

Weight of Coatings

- 1. Zinc**— Weight of zinc shall be 1.0 oz./ft.² +/- 0.1 oz./ft.² and shall be determined by the method described in ASTM A90.
- 2. Intermediate Coating**— Intermediate conversion coatings shall be 30 micrograms/in.² +/- 10 micrograms/in.² and shall be determined by a strip and weigh method utilizing an atomic absorption spectrophotometer or X-ray fluorescence spectrograph.
- 3. Polymer Coating**— Thickness of the clear polymer coating shall be 0.5 mils +/- 0.2 mils and shall be determined by measurement with a suitable magnetic or eddy current coating thickness tester.

Strength Characteristics

- 1. Load Strength**— The strength of line, end, corner and pull posts shall be determined by the use of 4' or 6' cantilevered bend test. The top rail shall be determined by a 10' free-supported beam test.
- 2. Bending Moment**— Pipe strength may be determined via the alternative method of calculating bending moment. (See table.) Conformance can be demonstrated by measuring the yield strength multiplied by the section modulus. The yield strength shall be determined according to the methods described in ASTM E8. For materials under this specification, the 0.2 offset method shall be used in determining yield strength.



Corrosion Resistance

1. Salt Spray

a. *Exterior Surface*—The exterior clear polymer coating shall have a demonstrated ability to resist 1,000 hours or more of exposure to salt fog with a maximum of 5% red rust. Tests shall be conducted in accordance with ASTM B117.

b. *Interior Surface*—The interior zinc-rich surface coating shall withstand no less than 650 hours of exposure to salt fog with a maximum of 5% red rust. Tests shall be conducted in accordance with ASTM B117.

2. Humidity—The exterior clear polymer coating of Wheatland WT-40 fence pipe shall resist 500 hours of exposure to 100% relative humidity without signs of blistering or peeling. Tests shall be performed in accordance with ASTM D4585 (D2247).

3. Weatherometer—The clear polymer coating of Wheatland WT-40 fence pipe shall resist failure for no less than 500 hours at a black panel temperature of no less than 145° F. Tests shall be performed in accordance with ASTM G155 Xenon Type BH apparatus (formerly G26) or ASTM G153 Carbon Arc Type HH apparatus (formerly G23).

Specifying Agencies

- American Association of State Highway and Transportation Officials (AASHTO) M181—Grade 2
- Federal specifications RR-F-191/2E and RR-F-191/3E
- U.S. Army Corps of Engineers UFGS-32 31 13
- Department of the Navy
- Federal Highway Administration
- Federal Aviation Administration AC 150/5370-10 Item 162
- U.S. Department of Justice—Federal Bureau of Prisons
- ASTM Specification F1043, Group IC, Standard Specification for Strength and Protective Coatings on Steel Industrial Chain Link Fence Framework
- American Institute of Architects (AIA) MasterSpec

WT-40 Dimensions and Strength Characteristics

FENCE INDUSTRY	DECIMAL OD EQUIVALENT		PIPE WALL THICKNESS		WEIGHT		SECTION MODULUS		X	MIN. YIELD STRENGTH		=	MAX. BENDING MOMENT	CALCULATED LOAD (LBS.)		
	OD	in.	(mm)	in.	(mm)	lb./ft.	(kg/m)	in. ³		(mm ³)	psi		(MPa)	lb./in.	10' Free Supported	Cantilever
														4'	6'	
→ 1½"	1.660	42.16	0.111	2.82	1.84	2.74	0.1962	4.98	x	50000	345	=	9810	327	204	136
1½"	1.900	48.26	0.120	3.05	2.28	3.39	0.2810	7.14	x	50000	345	=	14050	468	293	195
2½"	2.375	60.33	0.130	3.30	3.12	4.64	0.4881	12.40	x	50000	345	=	24405	814	508	339
→ 2½"	2.875	73.03	0.160	4.06	4.64	6.91	0.8778	22.30	x	50000	345	=	43890	1463	914	610
3½"	3.500	88.90	0.160	4.06	5.71	8.50	1.3408	34.06	x	50000	345	=	67042	2235	1397	931
4"	4.000	101.60	0.160	4.06	6.56	9.76	1.7820	45.26	x	50000	345	=	89098	2970	1856	1237

6½" and 8½" full-weight Schedule 40 per ASTM F1083 is available for terminal post applications.

Specifications, illustrated material and descriptions are accurate as known at time of publication and are subject to change without notice.

ASK FOR GAW EVERY TIME

GAW Chain Link Fabric provides exceptional security and protection in commercial, industrial, institutional, recreational and residential fencing applications. GAW also provides the best protection against corrosion in even the most severe coastal industrial environments. Hot dip zinc galvanizing is a simple process with over 200 years of proven effectiveness in millions of applications worldwide.

There are other zinc galvanizing processes and other metallic coatings, but none surpass GAW in durability and protection. It's a premium product providing superior corrosion and rust-resistance that doesn't cost a premium price.

THE IMPORTANCE OF GAW

GAW fabric is the only chain link fabric that's coated after weaving, ensuring that all surfaces of the base metal are protected. With GAW coatings, you have complete protection against rust and corrosion and an additional after coating treatment is applied to prevent white rust and early deterioration.

With any pre-coated wire, the weaving process leaves the twist and knuckle tips bare from trimming. Cut ends may be dipped in other materials, but they are no substitute for the thorough zinc coating protection of the GAW process.

THE DURABILITY OF GAW

Fabric galvanized after weaving is manufactured to the demanding requirements of ASTM specification A 392, which offers two classes of coating: Class 1 which has 1.2 ounces (366 g/m²) of zinc coating per sq. ft., and Class 2 which has 2.0 ounces (610 g/m²) of zinc coating per sq. ft. The effective service life of a fabric is directly related to the coating thickness – the thicker the coating, the longer the life. A Class 2 GAW coating is unsurpassed among metallic chain link fence coatings in providing long-term barrier and cathodic protection. That's a value you can measure.

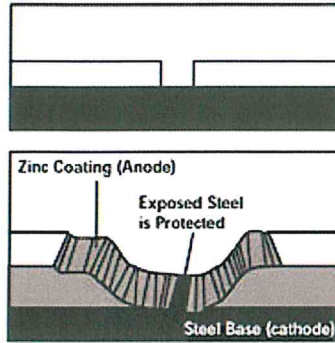

This is what happens to a scratch on galvanized steel. The zinc coating sacrifices itself slowly by galvanic action to protect the base steel. This sacrificial action continues as long as any zinc remains in the immediate area.

THE "SELF-HEALING" OF GAW

All zinc coatings have "self healing," or cathodic properties which protect exposed core metal. Even after years of wear, the remaining zinc stays alive. Of all metals used for protective coating of steel, zinc is the most electrochemically active in all environments, from mild rural to harsh marine and heavy industrial.

In other words, zinc provides a far superior coating in both barrier and cathodic protection... and GAW fabric provides the best of both.



THE FINISH OF GAW

Committed to their product, GAW producers assure you of chain link fabric with a complete coating. A continuous vertical dip and retrieval process removes excess zinc and keeps joints from welding.

THE VALUE OF GAW

When specifying chain link fabric, insist on GAW produced in accordance with ASTM A 392. If you're looking for durability and rust-prevention, there's no better chain link fencing than GAW. Fewer long-term maintenance problems mean lower long-term costs and greater life cycle savings. Pound for pound, GAW fabric is by far your best value.

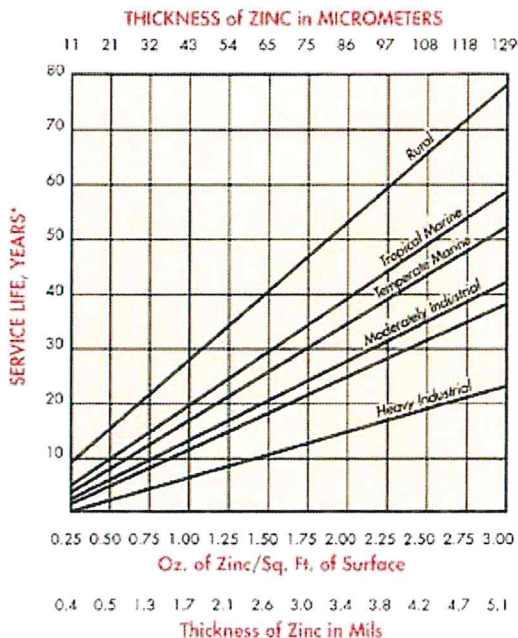

*Service life is defined as the time to 5% rusting of the steel surface.

Chart used with permission of the American Galvanizers Association.

GAW BENEFITS

1. Zinc-based process offers the most active cathodic protection
2. Heavier and more thorough coating with no flaking and bare trim ends
3. Additional protective coating to prevent white rust
4. All components of GAW fence systems are zinc coated
5. Consistently meets ASTM specifications
6. Established manufacturers produce consistent quality
7. Proven technology for 200 years
8. 15 Year Warranty
9. Lower long-term costs
10. Fewer long-term maintenance problems

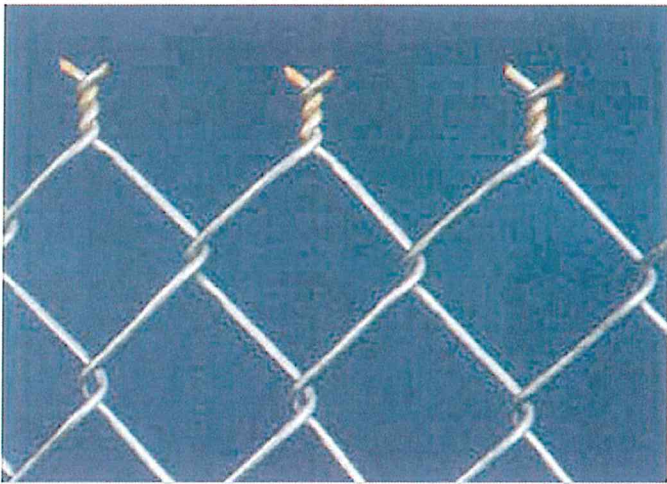

Pre-coated fabric with uncoated tips. With pre-coated fabric, some manufacturers coat the bare ends, but many don't. No one coats the ends with the same material that protects the rest of the fabric.



GAW fabric. The GAW process guarantees that cut ends will be coated with the same quality material and protection as the rest of the fabric. The pre-coated process provides no such guarantee.

GAW CHAIN LINK FENCING, A POPULAR CHOICE OF LANDSCAPE ARCHITECTS.

GAW Chain Link Fencing is resistant to defacement and offers total visibility. But when combined with landscaping, chain link provides an attractive visual barrier while maintaining security.



SECTION 02831 (GAW) Galvanized After Weaving (GAW) Fabric Specifications

PART 1 GENERAL

1.01 SECTION INCLUDES

A. Galvanized after weaving (GAW) coated chain link fencing and accessories.

1.02 SUBMITTALS

- A. Changes in specifications may not be made after the published date of bid. All submittals of substitutions must be approved before bid date.
- B. Shop drawings of fences and gates with all dimensions, details, and finishes. Drawings must include post foundations.
- C. Product data: Manufacturer's catalog indicating materials and a letter certifying that all conditions of the specifications have been met.

PART 2 PRODUCTS

2.01 MANUFACTURER

- A. Products from other qualified manufacturers who have five years or more experience manufacturing galvanized after weaving (GAW) chain link fencing will be considered by the architect as equal if they meet all specifications for design, size, gauge of metal parts and fabrication.
- B. Chain link fences and gates must be obtained from a single source.

2.02 CHAIN LINK FENCE FABRIC (See chart for fabric selections.)

A. Wire: ASTM A 392 Standard Specification for Zinc Coated Steel Chain Link Fence Fabric.

Choose one: 1.2 oz/ft² (366 g/m²) Class 1
or 2.0 oz/ft² (610 g/m²) Class 2

B. Chain link fence fabric shall be made of steel wire helically wound and interwoven in such a manner as to provide a continuous mesh without knots or lies except in the form of knuckling or twisting the ends of the wire to form the desired selvage of the fabric. Fabric height of _____ feet (_____ mm), mesh size of _____ inches (_____ mm), and a wire diameter of _____ inches (_____ mm). The wire breakload or strength to be _____ lbf (_____ N).

C. Selvage of fabric (specify knuckled or twisted) _____ top; _____ bottom.

PART 3 EXECUTION

3.01 EXAMINATION

- A. Verify areas to receive fencing are completed to final grades and elevations.
- B. Property lines and legal boundaries of work to be clearly established by the general contractor or property owner.

3.02 CHAIN LINK FENCE INSTALLATION

A. Install chain link fence in accordance with ASTM F 567.

GAW Chain Link Fence Fabric

Recommended Usage	Mesh Sizes Available	Gauge Coated Wire	Nominal Diameter Coated Wire	Height of Fence Fabric In Inches (mm)										Minimum Breaking Strength lbf (N)*
				36	42	48	60	72	84	96	108	120	144	
Industrial / Commercial	2" (50 mm)	6	0.192" (4.88 mm)	36	42	48	60	72	84	96	108	120	144	2170" (9650)
		9	0.148" (3.76 mm)	36	42	48	60	72	84	96	108	120	144	1290" (5740)
Industrial / Security	1" (25 mm)	9	0.148" (3.76 mm)	36	42	48	60	72	84	96	108	120	144	1290" (5740)
Tennis Court	1 1/4" (44 mm)	9	0.148" (3.76 mm)	36	42	48	60	72	84	96	108	120	144	1290" (5740)
		11	0.120" (3.05 mm)	36	42	48	60	72	84	96	108	120	144	850" (3780)
Security	1" (25 mm)	11	0.120" (3.05 mm)	36	42	48	60	72	84	96	108	120	144	850" (3780)
	3/4" (19 mm)			36	42	48	60	72	84	96	108	120	144	850" (3780)
	5/8" (16 mm)			36	42	48	60	72	84	96	108	120	144	850" (3780)
	1/2" (13 mm)			36	42	48	60	72	84	96	108	120	144	850" (3780)
	3/8" (10 mm)			36	42	48	60	72	84	96	108	120	144	850" (3780)
	3/8" (10 mm)	14	0.080" (2.03 mm)	36	42	48	60	72	84	96	108	120	144	n/a

Sizes printed in red meet ASTM A 392
*Meets ASTM A 817



866.888.5611
www.merchantsmetals.com

An Oldcastle Company



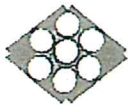

SUMIDEN WIRE
 PRODUCTS CORPORATION

Prestressed Concrete Strand Division

EAST: 710 MARSHALL STUART DR • DICKSON, TN 37055 • (866) 491-5020
 TEXAS: 1800 HIGHWAY 146 • DAYTON, TX 77535 • (866) 811-1120
 WEST: 1412 EL PINAL DR • STOCKTON, CA 95205 • (866) 246-3758

MILL CERTIFICATE OF INSPECTION

Order Number: SLPC191066-1

Page No : 1 OF 1

B/L No: SIPC192826

Issue Date : 08/08/2019

Commodity: Steel Strand, Uncoated Seven Wire for Prestressed Concrete

Size & Grade: 1/2" x 270 KSI

Specification: ASTM A416 - Latest 1/2" - Low Relaxation

Customer Name: BUILDERS POST TENSION INC

Customer P.O.: 13006-K

Destination: BUILDER - TEXAS

State Job No:

No	Pack #	Heat #	B.S.	Elong.	Y.P.	Area	REPRESENTATIVE	REPRESENTATIVE
							E-Modulus	CURVE#
			Min:41,300	3.5	37,170			
			(LB)	(%)	(LB)	(IN ²)	(MPSI)	
*1	T101463-4	T0206463	43,633	7.4	39,265	0.1521	28.8	101197R
*2	T101464-2	T0206064	43,646	6.7	40,205	0.1509	28.8	101197R
*3	T101473-1	T0208706	44,348	6.8	40,739	0.1527	28.8	101197R
*4	T101488-1	T1311293	44,729	7.7	39,967	0.1539	28.8	100780R
*5	T101488-2	T1311293	44,729	7.7	39,967	0.1539	28.8	100780R
*6	T101488-9	T1311293	44,729	7.7	39,967	0.1539	28.8	100780R
*7	T101491-9	T1311292	44,453	7.9	39,928	0.1549	28.8	100780R

We hereby certify that:

* We have accurately carried out the inspection of COMMODITY and met the requirements in accordance with the applicable SPECIFICATION, both listed above.

* The material described above will bond to concrete of a normal strength and consistency in conformance with the prediction equations for transfer and development length given in the ACI/AASHTO specifications.

* The individual below has the authority to make this certificate legally binding for SWPC.

Quality Assurance Section

Load - Elongation Curve

For Uncoated Seven Wire Steel Strand for Prestressed Concrete

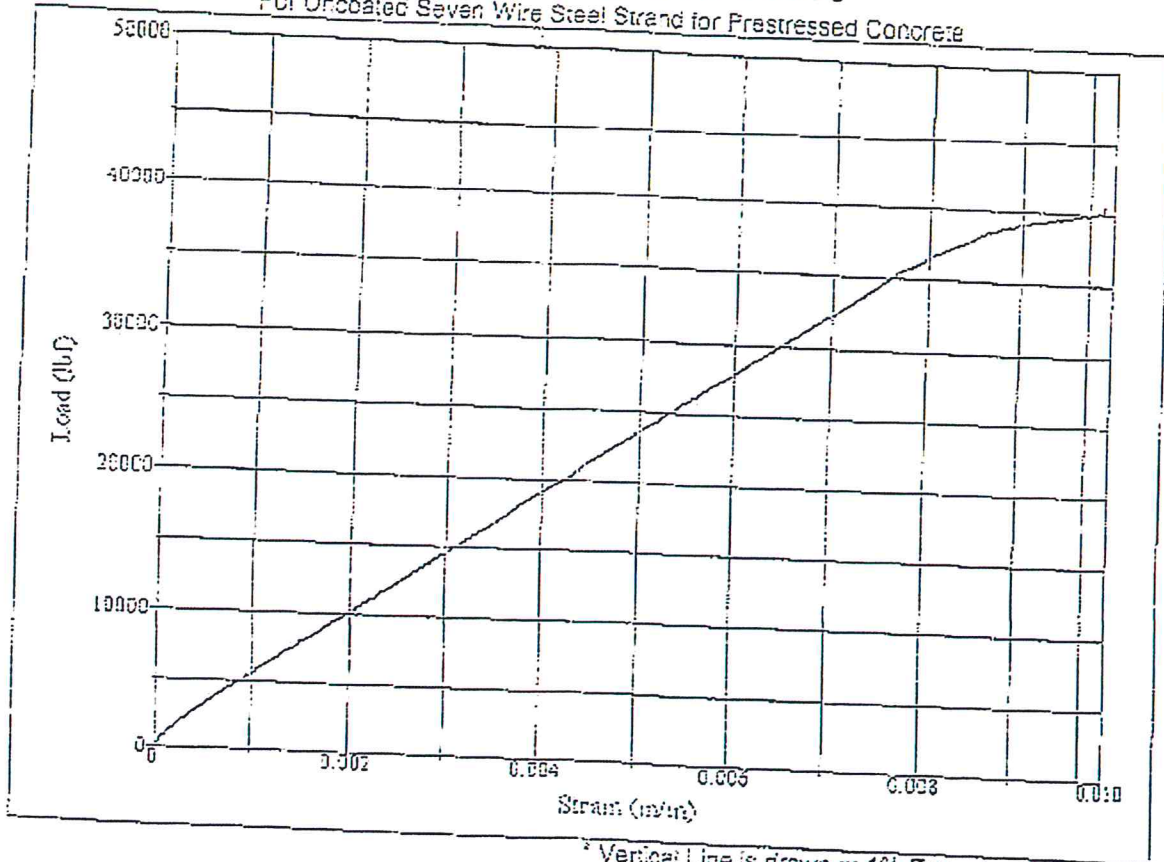

* Vertical Line is drawn at 1% Extension Under Load
 * Tested to ASTM A1061 Standards

Curve Number	T100780R
Size	1/2"
Grade	270K
Nominal Area	0.1520 in ²
Modulus	28.8 Msi

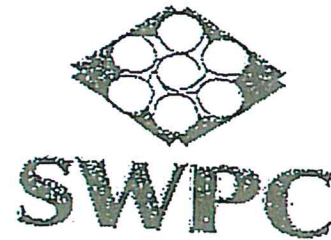

C. V. H.

Approval

Curve T100780R



BAMBERGER POLYMERS INC.
12600 N. FEATHERWOOD DR.
SUITE 300
HOUSTON, TX 77034
Tel: 281-481-9100
Fax: 281-484-6222

BPT DFW
Eastvale

BUILDERS POSTENTION
2220 MONEDA ST.
HALTOM CITY, TX 76117

8/07/19

Attn: ANGEL

Re: Material Certification

Customer PO #: 3148
Quantity: 44,092 LB
Bamberger Order #: 4136958
Arrival Date: 8/09/19
Product: BAPOLENE HDPE 2035
Lot #: B21003452

We look forward to your continued business. If you need further assistance, please do not hesitate to call.

Bamberger Polymers

Andrew L Fredericks

This document cannot be copied or reproduced, except in full, without the written approval of Bamberger Polymers, Inc. This document contains information that may be confidential and is intended only for the use of the addressee. Use of this information by anyone else is strictly prohibited. Except as stated in this document, no representations are made as to the physical properties or quality of the product. Neither Bamberger Polymers, Inc. nor any of its affiliates assume any liability whatsoever for the use of the information or the use of the product mentioned herein. Final determination of the suitability of any information or product for the use contemplated, the manner of use, environmental protection, regulatory compliance, and the health and safety of its employees is the sole responsibility of the user. Nothing herein waived or modifies any of the Seller's terms and conditions of sale, which govern this shipment.

Certificate of Quality

Date: 07/29/2019 **REVISED**

BEKAERT CORPORATION Van Buren , Arkansas

1881 BEKAERT DRIVE
 VAN BUREN, AR 72956
 TEL(479)474-5211 FAX(479)474-9075
 TELEFAX 537439

Customer	: BUILDER'S POST TENSION, INC	Our Order No	: 4212438731 / 000020
Final Customer	: Builders Post-Tension	Product No	: 0.5 LOW RELAX ASTM A416 GRADE 270
Customer Order No	: 2970	QTY	: 48000.000 FT
Customer Part No.	:	MFG SMP No	: PCU1027XZBAC12000
Customer Specification	: ASTM A416/A416-17		

Heat#	%C	%Mn	%P	%S	%Si
602407	0.82	0.70	0.010	0.016	0.23
OT0003352	0.81	0.63	0.010	0.007	0.24

Tag#	Heat#	Strand Diameter	Breaking Strength	Lay Length	Load @ 1% Elongation	Elongation	Elastic Modulus (MSI)
		"	lbf	"	lbf	%	
		0.4940	41300	6.00	37170	3.50	28.0
		0.5260		8.00		20.00	29.0
46159050	602407 OT0003352	0.5010	43818	7.01	40213	6.90	29.0
46159052	602407 OT0003352	0.5010	43818	7.01	40213	6.90	29.0
46159064	602407 OT0003352	0.5010	43818	7.01	40213	6.90	29.0
46159087	602407 OT0003352	0.5010	43818	7.01	40213	6.90	29.0

Material was melted and made in the U.S.A.

The undersigned certifies that the results are actual results and conform to the standards as contained in the records of this Corporation.

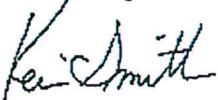

Kevin Smith
 Technical Quality Manager

Haltom City TX
7-30-19
41,960 lbs.

Martin Lubricants
6902 Palestine Street
Houston, TX 77020

Certificate of Quality Assurance

Customer: Builders PT
PO # 3114
Product Information: Post Tension Grease
Batch Information: M-374437
Quantity/Pkg.: Bulk
Date of Shipment: 07/29/2019
Destination: Haltom City, TX

Tests	Requirements	Results
Penetration, Worked	265-295	271
Drop Point, °C	148 min.	151
Color	Amber	Amber
Texture	Smooth	Smooth
Odor	Marketable	Mild
MOV cSt @ 40°C	139.9-153.8	149.5
Fatty Matter, Wt %	Report	8.1
Water, Wt %	0.1 max.	0.008
Raw Materials Recycle Content	Report	0

This product meets or exceeds the specification issued by the Post Tensioning Institute for corrosion preventive coatings.



Adtec Colorant Corporation

514 N. Great Southwest Pkwy. Arlington, TX 76011
Phone: 817-633-3004. Fax: 817-633-3099



Date: April 22, 2019 REV. 7-26-19

Certificate of Compliance

Code Number: 1AC9-31984UV

Lot Number: 66375

Color: Blue-UV

Let Down Ratio: 1/100 for HDPE

Blue, 1AC9-31984UV, has been formulated with UV stabilizers. These are necessary for a performance requirement of 90 days. The product must be used at its prescribed Let down ratio.

Sincerely,

Michael Bowes
Technical Manager
Adtec Colorant Corporation

This certificate does not predict performance in any application or system. We recommend the customer perform their own control tests to insure acceptable performance for their application.

13092-1



Date & Time Emailed: 07/25/2019 1:41 AM

Sent To: General Technologies Inc

SUBJECT: Production Material Certification (Ductile Iron)

Customer Part # & Rev. Level: 201751 A		
Description: SM1-05 Anchor .5	MTI Part Number:	201751
Product Cast Date: 07/25/2019	19206	DGY

This is to certify that for the period the subject castings were in production, our process was in control and producing ductile iron in conformance to:

Specification#: A536G80C

Grade: A536 80-55-06 BHN187

Typical Chemistry	Typical Mechanical	BHN Range	
Carbon (C): 3.810	Ultimate PSI: 106,000	191 - 206	
Silicon (Si): 2.560	Yield PSI: 58,000		
Manganese (Mn): 0.458	Elongation %: 10.5%	Radioscopy <input type="checkbox"/> Acceptable	
Sulfur (S): 0.010	Matrix Structure		
Phosphorus (P): 0.012	Nodularity %: 98		
Magnesium (Mg): 0.048	Pearlite %: 78		
Copper (Cu): 0.352	Carbide %: 0		

* This data parameter is not a requirement of the material specifications of this job.

Sincerely,

Mr. David Kesse
Metallurgist



704 W Simonds Road
 Dallas, Texas 75159
 P - 972.287.2390
 F - 972-287-4469

Quality Certification

PRECISION-HAYES INTERNATIONAL certifies that the products referenced herein comply with the specifications of the Post-Tensioning Institute.

S.O. #: 37959 Date: 7/11/2019 Quantity: 15,600
 PO #: 3077
 PHI Part No.: H008270 Desc: F500SL21.2 SLOCK 1/2 X 1.2 2PC
 Legacy Part No.: 501405

Heat Treat Lot # (s):
1908603
1917026
1917030
1917028
1916913

Base Material Certification #: Y129492

PHI Heat Treat Specification: **ES01-001**

Heat Treat	Hardness: HRA	Case Depth	Core Hardness
Minimum:	79	0.015"	
Compliance:	Yes	Yes	

PHI Quality Assurance:

Heat Treat	Hardness: HRA	Inspected Qty
Minimum:	79	Sample size meets or exceeds PTI and ACI
Compliance:	Yes	Yes

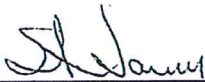

 PSL Quality Authorized Signature

7/11/2019

 Date

PRECISION-HAYES INTERNATIONAL maintains physical documentation of the above properties. PRECISION-HAYES INTERNATIONAL recommends that SURE-LOCK® components be used only in combination with other SURE-LOCK® anchorage products. Modification to the product or use with products other than PRECISION-HAYES INTERNATIONAL brand may void warranty.

The products referenced herein comply with the specifications of ICC-AC 303 as listed in ICC-ESR-2381 .

Customer inquiries, contact Sales and Marketing at 972-287-2390

MADE IN THE USA

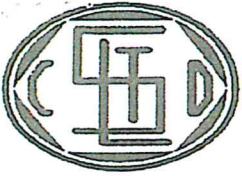

ST. LOUIS GOLD DRAWN
 PRODUCER OF GOLD FINISHED STEEL BARS

PRODUCT CERTIFICATION

WORK ORDER
034291

LOT NUMBER
Y129492

SALES ORDER / RLS
023138 / 002

CERT ID / REV
00084518 / 01

SOLD TO

Precision Sure-Lock
704 West Simonds
Seagoville, TX 75159
USA

CUSTOMER P.O. 36788	CUSTOMER PART H006287	QUANTITY 15,726 Lbs	Bundle 4	LADING NO 00031158	SHIPMENT DATE 05/21/2019
-------------------------------	---------------------------------	-------------------------------	--------------------	------------------------------	------------------------------------

SPECIFICATION **DRD1000012L14PSL-1**
 Size Min/Max: **0.9980/1.0000"**
 Shape: **Round**
 Form: **Dead Length**
 Grade: **12L14**
 Length Min/Max: **144.000/146.000"**
 Paint Color: **WHITE - BOTH ENDS**

CERTIFICATION REQUIREMENTS

- 1. Material produced to ASTM A-108 or applicable customer requirements.**
- 2. Physical result tested in accordance with ASTM A-370.**
- 3. Chemistry result as supplied by hot rolled mill.**

Chemical

C %	Mn %	P %	S %	Si %	Cu %	Ni %	Mo %	Cr %	Cb %	V %
0.07	1.12	0.045	0.308	0.016	0.043	0.027	0.002	0.029	0	0.004
Al %	Nppm	Pb %	Sn %	B %	NCMC					
0.0012	57	0.272	0.003	0	.10					

Mechanical

<u>TEST</u>	<u>UNITS</u>	<u>Result</u>
Tensile Strength (PSI)	PSI	77600

Mill Source

<u>TEST</u>	<u>RESULT</u>
Mill Source	GLOBAL STEEL
Country of Origin	Spain

I certify that the above figures are a true and correct copy of those contained in the records of this company.

Douglas® Pickleball



PICKLEBALL Premier™ RD Posts

Uses 54" l posts (36" above ground)
 Green (Item # 63070)
 Black (Item # 63071)
 The Premier™ 3" OD round (RD) posts are constructed of heavy-duty 11-gauge steel. Posts are internally wound and feature a self-locking gear mechanism. Gears are constructed of plated steel and the small gear is case hardened. Gear housings and caps are made of cast aluminum alloy. Gear function is 30:1 to ensure a smooth, easy operation. Posts are finished in forest green or black baked-on polyester powder coat finish to resist rust and increase durability. Integrated welded steel lacing rods are included for a professional net installation. Gear plate cover and removable handle are chrome plated.

3"

3" Corresponding Ground Sleeves:
 24" Steel Ground Sleeve (GS-24) (Item # 63424)

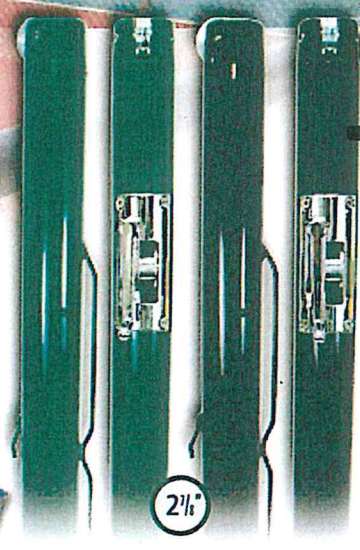

PICKLEBALL Premier™ XS Posts

Uses 54" l posts (36" above ground)
 Green (Item # 63074)
 Black (Item # 63075)
 The Cadillac of tennis posts is available for pickleball court construction measuring 54" in length to sit 36" above ground. These 2-7/8" OD round posts are constructed of 8-gauge steel. Posts are internally wound and feature a jam-free cable tensioning hardware system. Plated steel gear housings and caps are made of die-cast zinc. Gear function is 30:1 to ensure a smooth, easy operation. Posts feature Allied's® superior Flo-coat® galvanization process and are then finished in forest green or black baked-on polyester powder coat to resist rust and increase durability. Integrated welded steel lacing rods are included for a professional net plate cover and removable handle are chrome plated.

2 7/8"

2 7/8" OD Corresponding Ground Sleeves:
 24" PVC (GS-24PVC) (Item # 63164)
 24" Aluminum (GS-24RD) (Item # 63171)

Featuring Allied's® Flo-coat® Process

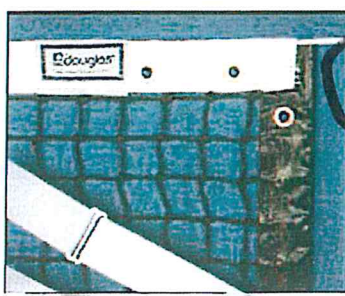
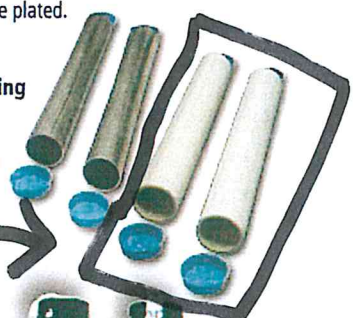

PICKLEBALL Nets

Uses standard 36" h nets, 22' long 36" h x 21'9" l (JTN-30) (Item # 20105) Optional shorter height 30" h x 21'9" l (PN-30) (Item # 20103)
 These Douglas® nets meet the USAPA and USTA's requirements for official Pickleball net sizes. Netting is 1-3/4 square mesh braided 3.0mm polyethylene, unsurpassed for durability and weather resistance. Headbands are made of vinyl coated polyester and have been lock-sewn with four rows of #32 white polyester thread. Vinyl bottom tape and side pockets are polyester based and won't shrink, mildew or rot when exposed to the elements. Bottom and side tapes are double lock-stitched with black polyester thread.

Adjustable Center Straps
 Perfect for adjusting the center of the net to 34" high.

Classic ACS (Item # 20603)
 Made from heavy-duty 2" polyester white web. Features a non-slip reverse nickel plated web slide with double ended snap.

Deluxe ACS (Item # 20600)
 Made from heavy-duty 2" polyester white web. Features a non-slip nickel plated reverse web slide and swivel bolt loop snap.

Center Pipe Anchor
 (Item # 63428)
 9" long aluminum pipe tie down anchor with pin for use with center strap.

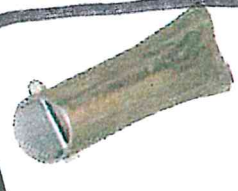

PICKLEBALL E-Z 36 Post

Uses 54" l posts (36" above ground)
 Green (Item # 63072)
 Black (Item # 63073)
 With quality looks and performance these posts are an E-Z choice. Posts are sized for pickleball court construction measuring 54" in length to sit 36" above ground. These external wind 2-7/8" OD round posts are constructed of durable 8-gauge steel. E-Z Posts feature Allied's® superior Flo-coat® galvanization process and are then finished in forest green or black baked-on polyester powder coat to resist rust and increase durability. The enhanced aluminum E-Z Reel components increase the strength and stability of the reel mechanism. When combined with the smooth action of the die-cast zinc top cap the E-Z tennis post delivers a more solid and consistent quick-winding and quick-release performance than you would expect with this style of post. Reel handle is removable with a quick-release pin to prevent unwanted tampering.

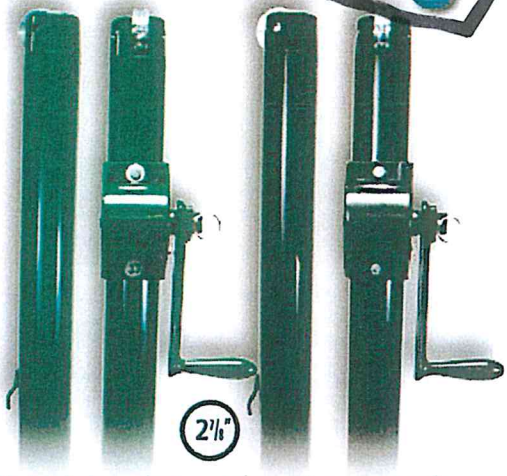

2 7/8"

December 22, 2017

Re: Renner Sports Surfaces – Ownership of Designs and Drawings

To All Interested Parties:

The designs and drawings of L.E.R., Inc. d/b/a Renner Sports Surfaces (“Renner”), including, without limitation, those of its affiliated and related entities, are subject to protection by U.S. copyright laws. Specifically, Renner is proud of its post-tensioned concrete system and committed to the protection thereof.

Renner’s post-tensioned concrete designs and drawings, including, but not limited to, the use, reproduction and distribution thereof, is strictly prohibited without Renner’s express written consent. Renner will consider legal action to protect its rights under applicable copyright laws and other applicable laws for any infringing activity.

Please feel free to contact any member of the Renner team if you have any questions.

Regards,



Tim Prochko
Senior Legal Counsel
Tarkett Sports
tim.prochko@tarkettsports.com



**THE BALL IS
IN YOUR COURT**

THE TARKETT SPORTS FAMILY - LEADERS IN SPORTS SURFACING



Oregon Office
503-691-2484

Utah Office
801-269-9991

Denver Office
800-738-8106

rennersports.com

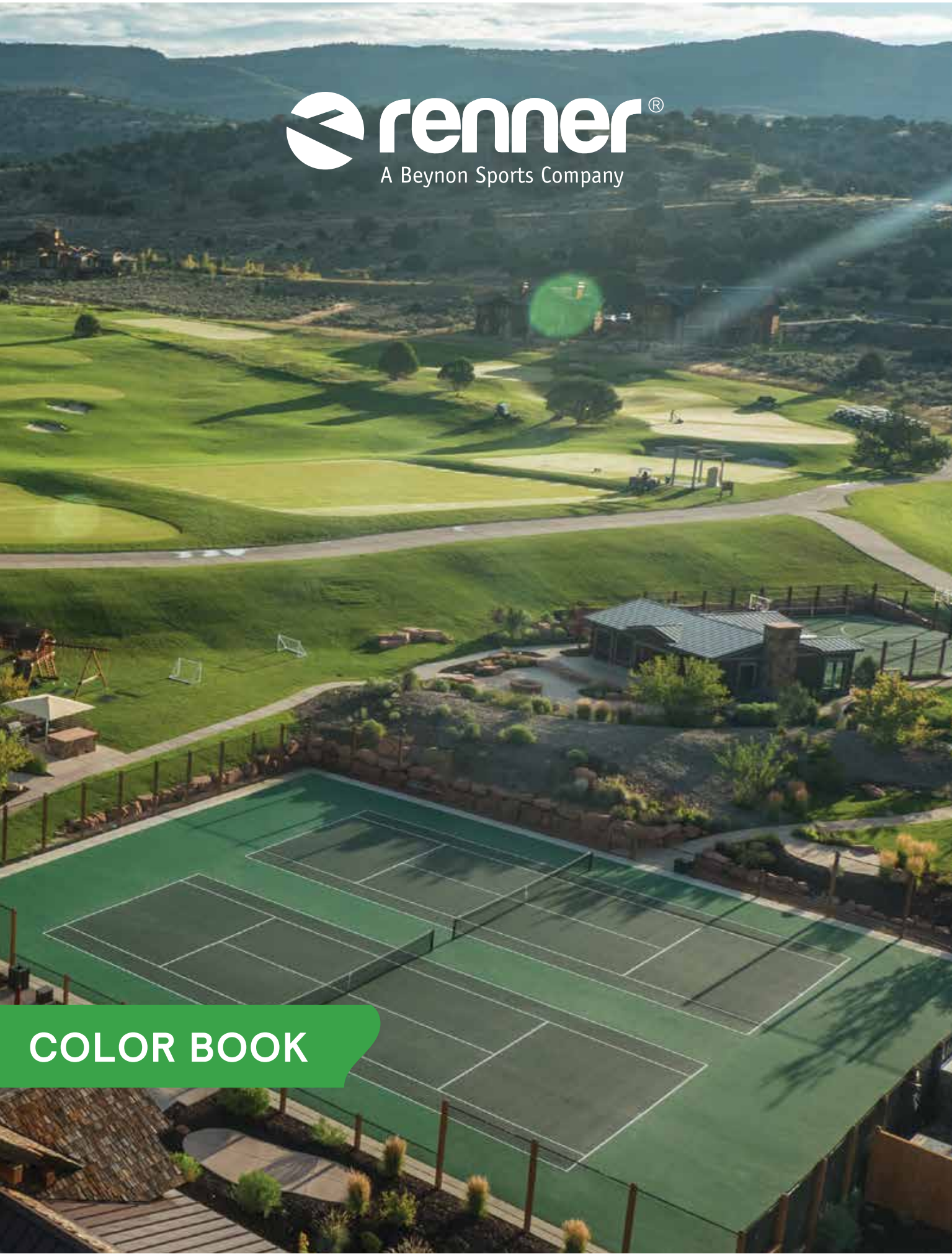

 **renner**[®]
A Beynon Sports Company

COLOR BOOK

TRUST THE RENNER DIFFERENCE

ITF Tested and proven, Renner acrylic coatings offer elite performance, durability and color retention. The systems are designed to withstand harsh weather and provide superior playing characteristics and ball bounce.

For over 20 years, Renner has been a leader in manufacturing high-performance tennis court coatings. Our surfaces are found at some of the most prestigious venues across North America, and we're committed to elevating performance and keeping athletes safe through innovative surfaces designed for competition and daily training.

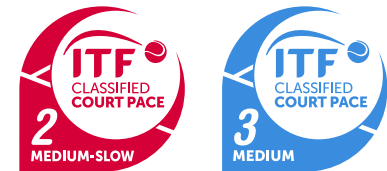

ITF CLASSIFIED

Renner acrylic coatings offer a variety of textures and are ITF Classified Court Pace 2 (Medium Slow) and 3 (Medium).



QUALITY MATERIAL

Our coating systems are comprised of premier quality 100% acrylic resins and pigments showcasing leading durability and resistance to deterioration from harmful UV exposure.



PROVEN DURABILITY

Proven in a variety of environments, Renner coatings have long been recognized as one of the leading tennis court systems in North America. Trusted by community, club, park, collegiate, and residential clients, Renner coatings have a track record to prove it.



ENVIRONMENTALLY-FRIENDLY

Designed to be green, our systems are manufactured with environmentally-friendly materials for use on asphalt or concrete substrates. Renner coatings contain no lead, mercury or asbestos.

POPULAR COURT DESIGNS

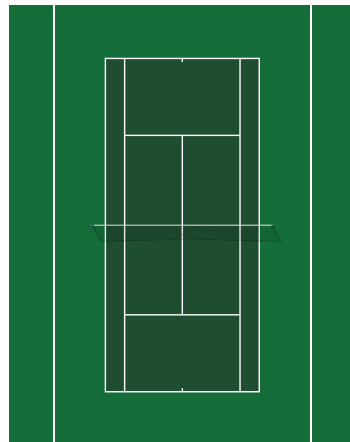

Dark Green - Light Green

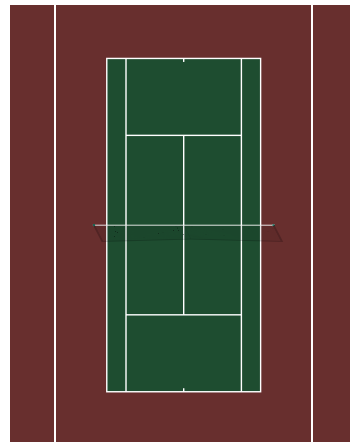

Dark Green - Maroon

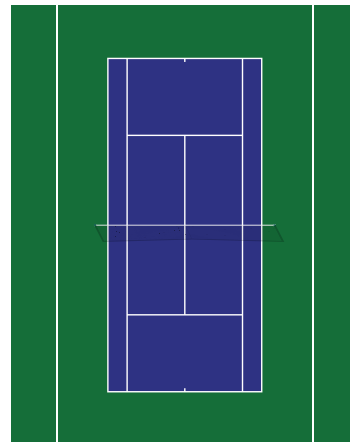

Dark Blue - Light Green

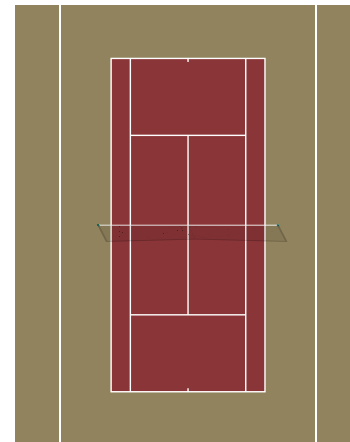

Brick Red - Khaki



Images used for illustrative purposes only and are not accurate representations of the actual products. As such, size, colors and materials may vary.



DARK GREEN



LIGHT GREEN



BRICK RED



MAROON



DARK BLUE



MEDIUM BLUE



KHAKI



GREY



THE ULTIMATE
SURFACE EXPERIENCE

PRODUCT DESCRIPTION & TECHNICAL SPECIFICATIONS FOR RSS CONCRETE PRIMER

PRODUCT DESCRIPTION:

RENNER SPORTS SURFACES CONCRETE PRIMER is a high solids 100% acrylic material designed to promote adhesion of RENNER SPORTS SURFACES ACRYLIC SYSTEMS to uncoated concrete. Provided in a concentrate solution, simply add water and mix. Apply with a rubber bladed squeegee or push broom. Do not leave excess pools of primer in low areas of court.

RENNER SPORTS SURFACES CONCRETE PRIMER formulations contain NO VINYL ACRYLICS, NO ETHYLENE GLYCOLS, NO ASPHALTIC EMULSIONS, NO ASBESTOS and NO MERCURY.

TECHNICAL SPECIFICATIONS FOR RENNER SPORTS SURFACES CONCRETE PRIMER

- Coverage:** Approximately 300 square feet per gallon of diluted material. Coverage may vary due to concentrate porosity, method of application, and temperature.
- Drying:** Dries in approximately one hour, based on 70 degree F and 50% humidity. Allow 24 hours to cure before applying RENNER SPORTS SURFACES SURFACING SYSTEMS.
- Dilution:** Mix one part CONCRETE PRIMER to two parts cool, clean water
- Packaging:** 55 gallon containers



THE ULTIMATE
SURFACE EXPERIENCE

PRODUCT DESCRIPTION & TECHNICAL SPECIFICATIONS FOR RSS PATCH BINDER

PRODUCT DESCRIPTION:

RENNER SPORTS SURFACES TEXTURED PATCH BINDER is a Polymeric concrete modifier developed for the purpose of patching low areas (bird baths) and filling cracks on concrete and asphalt Tennis Courts. When RENNER SPORTS SURFACES PATCH BINDER is mixed with Portland cement and sand, it increases the strength of the cement patch and promotes adhesion to both existing surfaces and the RENNER SPORTS SURFACING SYSTEM. RENNER SPORTS SURFACES PATCH BINDER may also be used as concentrate slurry to be applied over unsurfaced concrete pavements. All patched or slurried areas should be etched with an acid solution and washed clean.

RENNER SPORTS SURFACES PATCH BINDER formulations contain NO VINYL ACRYLICS, NO ETHYLENE GLYCOLS, NO ASPHALTIC EMULSIONS, NO ASBESTOS and NO MERCURY.

TECHNICAL SPECIFICATIONS FOR RENNER SPORTS SURFACES PATCH BINDER

% Solids: 47%

Dilution for Patch Binder: Mix 100 pounds of Silica Sand with two gallons of (sifted) Portland cement. Add undiluted RENNER SPORTS SURFACES PATCH BINDER until desired consistency is achieved. Before patching bird bath areas, prime the areas with one part RENNER SPORTS SURFACES PATCH BINDER and two parts water. Larger sand may be used in deeper patches, but smaller sand (the size used in the color coating) should be used near the top of patch.

Dilution of Slurry Coat: Mix 200 pounds of Silica Sand with one bag of Portland cement. Add ½ gallons of RENNER SPORTS SURFACES PATCH BINDER and 5 gallons of water. MIX WELL! Should be applied in cool temperatures or court should be misted with water. Coverage of this mix is approximately 1600 to 1800 square feet.

Packaging: One, Five and Fifty-Five gallon containers



THE ULTIMATE
SURFACE EXPERIENCE

PRODUCT DESCRIPTION & TECHNICAL SPECIFICATIONS FOR RSS TEXTURED LINE PAINT

PRODUCT DESCRIPTION:

RENNER SPORTS SURFACES TEXTURED LINE PAINT is formulated 100% Acrylic Resins and the highest quality white pigments available. RENNER SPORTS SURFACES TEXTURED LINE PAINT provides super white brightness and excellent hiding. Texture is added to provide the same speed and true ball bounce experienced throughout the rest of the RENNER SPORTS SURFACE SYSTEM.

RENNER SPORTS SURFACES TEXTURED LINE PAINT formulations contain NO VINYL ACRYLICS, NO ETHYLENE GLYCOLS, NO ASPHALTIC EMULSIONS, NO ASBESTOS and NO MERCURY. RENNER SPORTS SURFACES TEXTURED LINE PAINT contains over three and one half (3 ½) pounds of Titanium Dioxide per gallon.

TECHNICAL SPECIFICATIONS FOR RENNER SPORTS SURFACES TEXTURED LINE PAINT

<u>PIGMENTS:</u>		<u>38%</u>
Titanium Dioxide Pigments	28%	
Silica & Extenders	10%	
<u>VEHICLE:</u>		<u>62%</u>
Acrylic Emulsion	23%	
Minor Additives	2%	
Volatiles (Including Water)	37%	
<u>TOTAL:</u>		<u>100%</u>

Weight by gallon:	12.5 pounds
% Solids by weight:	60%
% Acrylic:	25%
Rate of Application:	One gallon per court, used undiluted
Packaging:	One and Five gallon containers
Colors:	White



THE ULTIMATE
SURFACE EXPERIENCE

PRODUCT DESCRIPTION & TECHNICAL SPECIFICATIONS FOR RSS ACRYLIC RESURFACER

PRODUCT DESCRIPTION:

RENNER SPORTS SURFACES ACRYLIC RESURFACER concentrate is a high solids 100% acrylic material designed for asphalt and concrete pavements. RENNER SPORTS SURFACES ACRYLIC RESURFACER is to be mixed with silica sand and water at the job site. It may be used to correct minor bird baths, fill voids and blemishes in pavement, and to re-establish consistent texture prior to applying RENNER SPORTS SURFACES COLOR COATING SYSTEMS.

RENNER SPORTS SURFACES ACRYLIC RESURFACER formulations contain NO VINYL ACRYLICS, NO ETHYLENE GLYCOLS, NO ASPHALTIC EMULSIONS, NO ASBESTOS and NO MERCURY.

TECHNICAL SPECIFICATIONS FOR RENNER SPORTS SURFACES ACRYLIC RESURFACER

<u>PIGMENTS:</u>		<u>27.23%</u>
Black Iron Oxide	4%	
Silica & Extenders	23.23%	
<u>VEHICLE:</u>		<u>72.77%</u>
Acrylic Emulsion	37%	
Minor Additives	1.2%	
Volatiles (Including Water)	34.57%	
<u>TOTAL:</u>		<u>100%</u>

Weight by gallon:	12.5 pounds
% Solids by weight:	63%
% Acrylic:	37%
Rate of Application:	.04 - .06 undiluted gallons per square yard
Mixing:	18 gallons Acrylic Resurfacer, 12 gallons of water and 150-200lbs of Silica Sand
Packaging:	Fifty-Five gallon containers
Colors:	Black



THE ULTIMATE
SURFACE EXPERIENCE

PRODUCT DESCRIPTION & TECHNICAL SPECIFICATIONS FOR RSS ACRYLIC COLOR CONCENTRATE

PRODUCT DESCRIPTION:

RENNER SPORTS SURFACES COLOR CONCENTRATE is the highly pigmented, 100% acrylic color coating system designed specifically for asphalt and concrete surfaces. RENNER SPORTS SURFACES COLOR CONCENTRATE may be used for textured coats and topcoats. For textured coats simply dilute color concentrate with water and silica sand. The speed of play and ball bounce can easily be adjusted by varying the size and amount of silica sand to the concentrate. To provide a protective, in-depth color topcoat, simply add water to the color concentrate.

RENNER SPORTS SURFACES COLOR CONCENTRATE formulations contain NO VINYL ACRYLICS, NO ETHYLENE GLYCOLS, NO ASPHALTIC EMULSIONS, NO ASBESTOS and NO MERCURY.

<u>PIGMENTS:</u>		<u>23.64%</u>
Vary by color		
<u>VEHICLE:</u>		<u>76.36%</u>
Acrylic Emulsion	28.51%	
Minor Additives	1.9%	
Volatiles (Including Water)	45.95%	
<u>TOTAL:</u>		<u>100%</u>

Weight by gallon:	10 pounds
% Solids by weight:	44%
% Acrylic:	25.9%
Rate of Application:	.03 - .06 gallons per square yard
Dilution:	A. Texture coats- 2 part concentrate, 1 part water, 1 part sand B. Topcoat- Equal parts concentrate and water
Packaging:	One, Five and Fifty-Five gallon containers
Colors:	Dark Green, Light Green, Khaki, Dark Blue, Medium Blue, Brick, Grey and Maroon

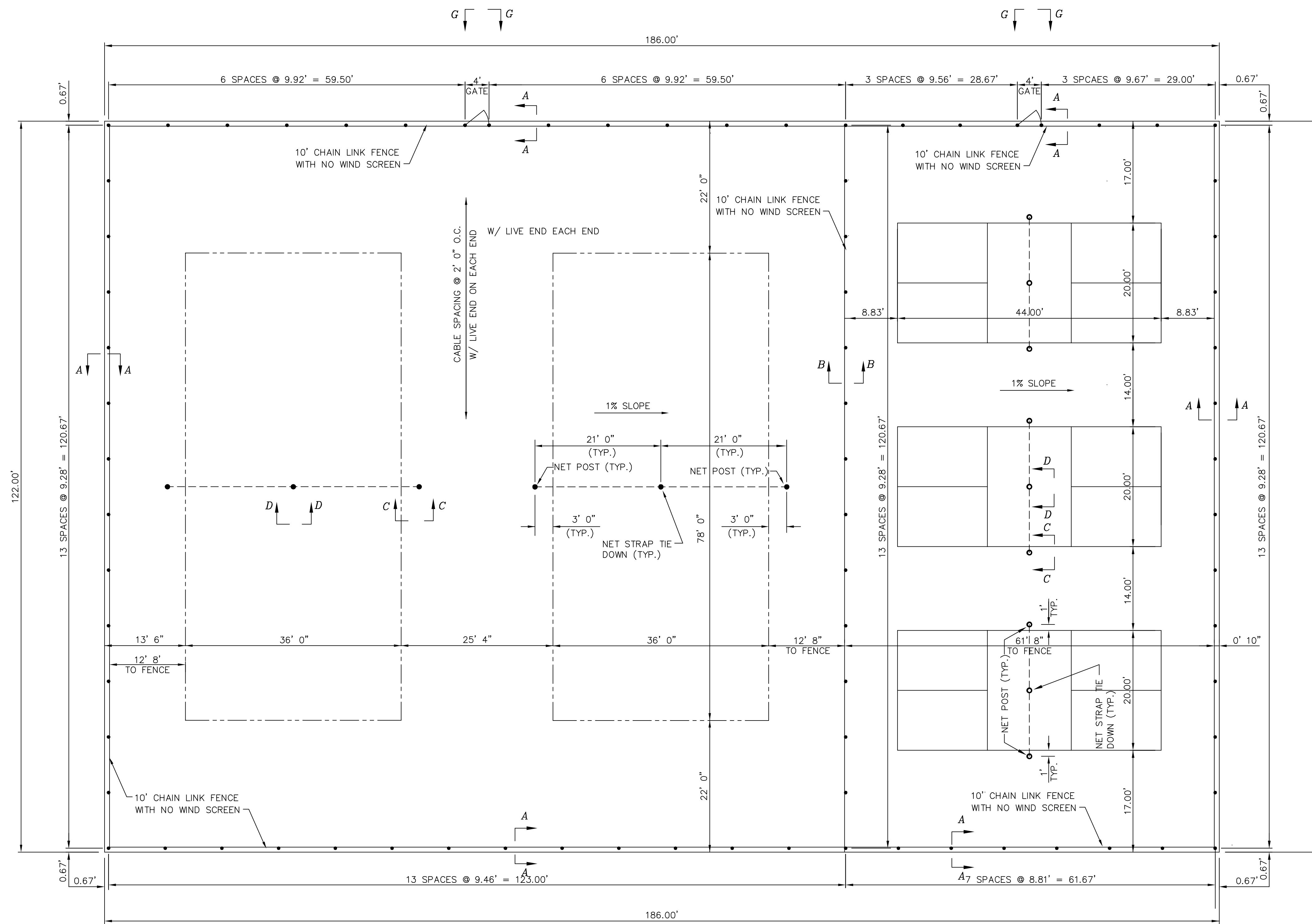

3 TENNIS COURTS & 3 PICKLEBALL COURTS PLAN

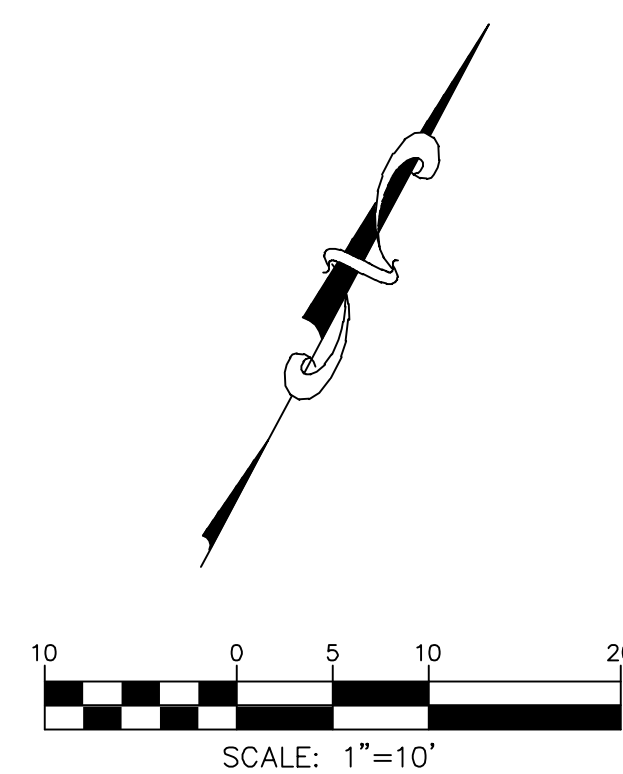

NOTES:

1. ALL CONCRETE WILL BE A MINIMUM OF 4000 PSI STRENGTH AT 28 DAYS, NON FIBERMESH.
2. ADEQUATE DRAINAGE AWAY FROM THE SLAB IS REQUIRED. A MINIMUM OF 6 INCH DROP IN THE FIRST 5 FEET AWAY FROM THE SLAB ON ALL SIDES.
3. DESIGN IS BASED ON PTI'S DESIGN REQUIREMENTS FOR POST-TENSIONED SPORTS COURTS, 2006.
4. THE 2 7/8" FENCE POSTS ARE NOT DESIGNED FOR WIND SCREEN LOADING

REVISIONS	DATE

PROJECT: TRAILS @ CROWFOOT TENNIS, PICKLE BALL & BASKETBALL COURTS
 PARKER, COLORADO
 DRAWING: TENNIS, PICKLEBALL & BASKETBALL LAYOUT PLAN
 CLIENT: RENNER SPORTS
 DESIGNED BY: K.W.S.
 DRAWN BY: K.W.S.
 CHECKED BY: K.W.S.
 HORIZ. 1"=10'
 SCALE: VERT. N/A
 DATE: 12/13/2019

KWS
 ENGINEERING & DEVELOPMENT CONSULTANTS
 PHONE: (303) 832-1377
 FAX: (303) 832-1569
 1580 LINCOLN STREET SUITE 770
 DENVER, CO 80203

SHEET NUMBER
 1
 PROJECT No. 2019-19
 SHT 1 OF 3 SHTS

TENNIS-

Douglas® Premier™ XS

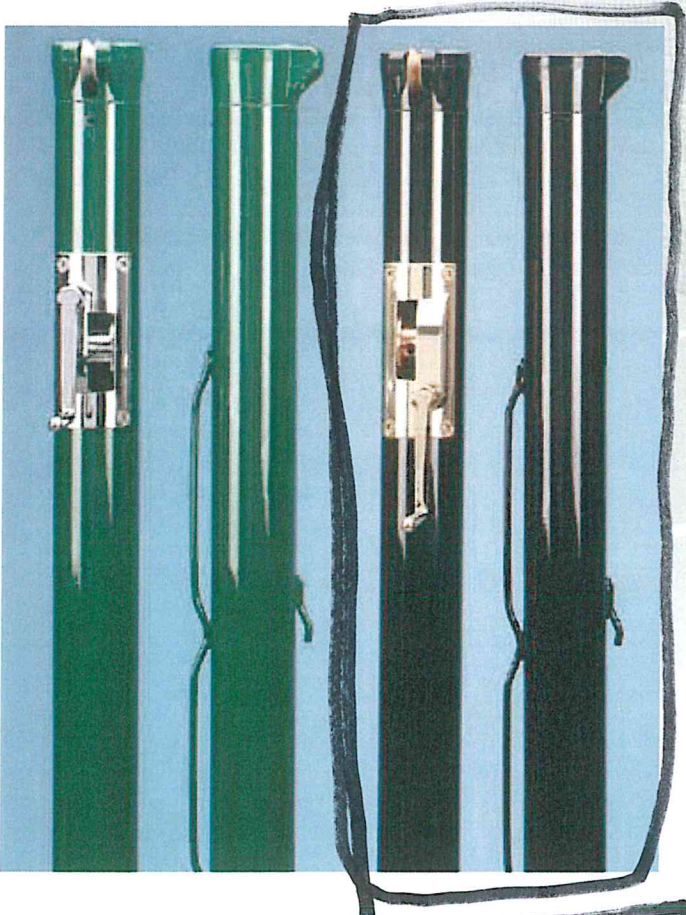

Premier XS Features:

- 2-7/8" OD round 8-gauge steel
- Complete with welded lacing rods
- Die-cast zinc caps and gear housings
- Available in forest green, black or open tournament blue
- Baked on polyester powder coat finish
- Jam-free cable tensioning hardware system with superior hardened gears and case
- Easy-to-operate post with a 30:1 self locking gear ratio
- Gears are available in three superior materials: stainless steel, plated steel or brass
- Flush mounted removable handle
- Hardware is available in optional chrome or brass finish
- Optional Ground Sleeves sold separately



Gears are available in three superior materials:

- Stainless Steel
- Plated Steel
- Brass

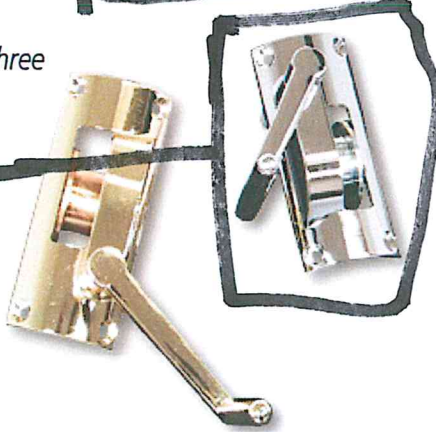

Choose from three colors:
Green, Black & Open
Tournament Blue

Featuring Allied's®
Flo-coat® Process:

A Superior
Galvanization
Process



Premier XS Post Options

Plated Gears: Green (Item # 63032)
Black (Item # 63034)
Open Tournament Blue (Item # 63033)

Brass Gears: Green (Item # 63032BR)
Black (Item # 63034BR)

Stainless Steel Gears: Green (Item # 63032SS)
Black (Item # 63034SS)

Corresponding Ground Sleeves:

24" PVC Ground Sleeve (GS-24PVC) (Item # 63164)
24" Aluminum Ground Sleeve (GS-24RD) (Item # 63171)

Douglas® Tennis Nets

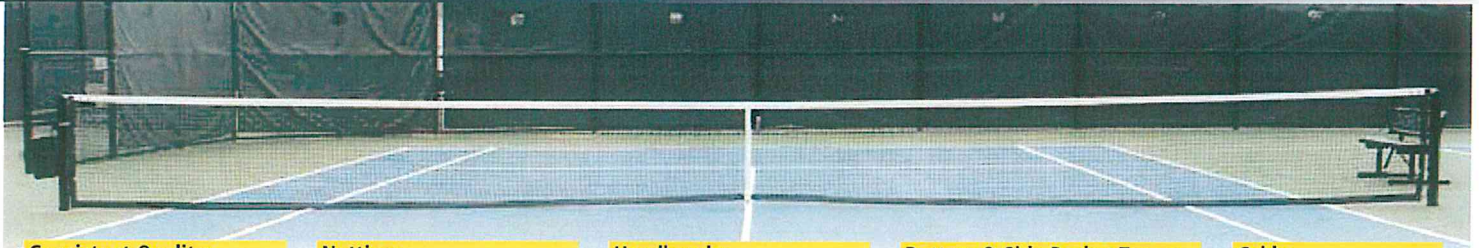

Consistent Quality:

With Douglas® tennis nets, you get consistent, long-lasting performance. All Douglas® tennis nets meet USTA requirements for official size -42' x 3'6". In addition, Douglas® nets carry a pro-rata warranty guaranteeing superior durability and longer net life. See for yourself why Douglas® nets are the brand of choice.

Netting:

Netting is 1-3/4" square mesh braided solid core polyethylene unsurpassed for durability and weather resistance. Championship nets are made from 3.5mm with 325# break strength, Tournament and Recreation nets are made from 3.0mm with 285# break strength.

Headbands:

Headbands are constructed using heavy-duty vinyl coated polyester or durable polyester webbing material that withstands the elements and won't shrink, rot or mold. Headbands are sewn to the netting with four rows of 32# white polyester thread -the heaviest in the industry.

Bottom & Side Pocket Tapes:

Bottom and side pocket tapes are made of heavy-duty vinyl coated polyester and won't shrink, mildew or rot when exposed to the elements. Fiberglass dowels in the side pockets keep the net taut and attractive. Heavy duty brass grommets and lacing cord lets you pull the net snugly up to each post.

Cable:

All Douglas® tennis nets come complete with a vinyl coated, 5/32" galvanized steel cable with break strength of 2300#. Both ends have double-swaged loops.



TN-45

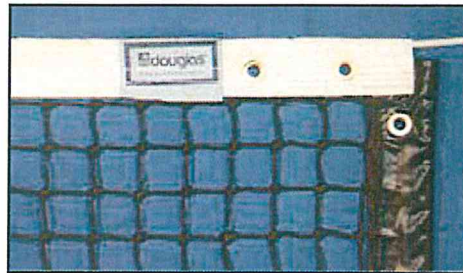

TN-36T



TN-30DH

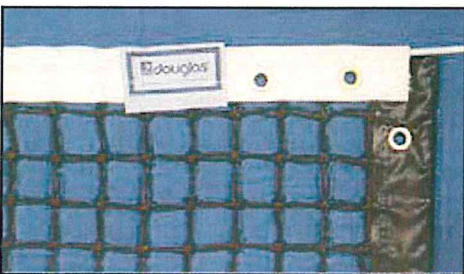

TN-28DM

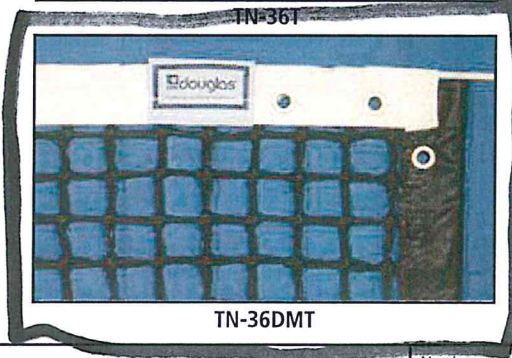

TN-36DMT

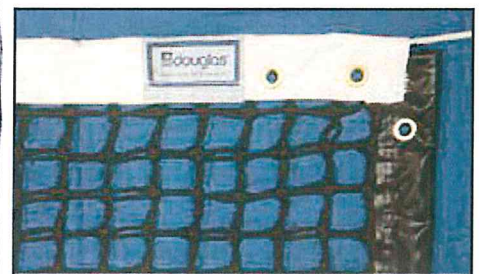

TN-30DM

Item #	Net	Headband		Netting			Warranty
		Material	Weight	Size	Break Strength	Top 6 Rows Double Mesh	
Professional Nets							
20045	TN-45	Double thick 100% polyester	48 oz	3.5 mm	325 lb.	No	5 Year Warranty
20045	TN-40 (not pictured)	Vinyl Coated Polyester, 2-ply	65 oz (20 oz./sq. yd.)	3.5 mm	325 lb.	No	5 Year Warranty
Championship Nets							
30036T	TN-36T -tapered	Vinyl Coated Polyester, 2-ply	65 oz. (20 oz./sq. yd.)	3.5 mm	325 lb.	No	5 Year Warranty
30038TD	TN-36DMT -tapered	Vinyl Coated Polyester, 2-ply	65 oz. (20 oz./sq. yd.)	3.5 mm	325 lb.	Yes	5 Year Warranty
Tournament Nets							
30029	TN-30	Vinyl Coated Polyester	32 oz./sq. yd.	3.0 mm	285 lb.	No	4 Year Warranty
30030	TN-30DM -tapered	Vinyl Coated Polyester, 2-ply	65 oz. (20 oz./sq. yd.)	3.0 mm	285 lb.	Yes	4 Year Warranty
30060	TN-28DM	Durable Polyester Web	N/A	3.0 mm	285 lb.	Yes	4 Year Warranty



Douglas® Tennis Net Accessories

Bottom Taper Option

(Item # 20062)

Most Douglas® tennis nets can be bottom fit by tapering the net bottom from 42" at the ends to 36" at center. This reduces the amount the net rubs on the court surface prolonging the life of the net.

Specialty Nets

Feature vinyl coated polyester headbands with 3.0 polyethylene netting. 4 Year warranty.

Singles Tennis Nets: 3'6" x 33'

Paddle Tennis Nets: 32" x 21'10"

Platform Tennis Nets: 3' x 23'

QuickStart Tennis Nets: 3' x 21'9"

Pickleball Tennis Nets: 3' x 21'9"



Adjustable Center Straps

All Douglas® Center Straps feature 2" polyester webbing with a water repellent finish that reduces staining and fading. The snaps and slides are nickel plated for rust resistance, making them an excellent choice for both outdoor and indoor use. Douglas center straps are adjustable to 3' with any anchoring system.

Procam ACS (Item # 20625)

2" cam buckle, with swivel loop bolt snap

Velcro ACS (Item # 30602)

Velcro adjustment, with swivel loop bolt snap

Classic ACS (Item # 30603)

Non-slip reverse web slide with double ended snap

Basic ACS (Item # 30600)

Non-slip reverse web slide with swivel loop bolt snap

Deluxe ACS (Item # 20600)

Non-slip reverse web slide with swivel loop bolt snap

Center Pipe Anchor (Item # 63428)

1.9" OD Galvanized Steel



Replacement Snaps

Loop Snap (Item # 10601)

2" replacement loop snap

Double Snap (Item # 10604)

Double ended bolt replacement snap



Replacement Headbands

Polyester (HB-42) (Item # 30042)

Heavy-duty polyester web lacing eyelets on 6" centers, includes lacing cord.



Vinyl (HB-42V) (Item # 30040)

Heavy-duty 28 oz vinyl coated polyester. Eyelets spaced on 6" centers. Includes lacing cord.



Lacing Cord

TNLC (Item # 10338)

Tennis net lacing cord; 2 pieces of 4 mm white polyester braided cord 4' long and 2 pieces 3 mm braided polyethylene 15' long.

Cord 3mm (Item # 10337)

500' spool of 3 mm braided polyethylene



Replacement Cable

(RVC-47) (Item # 20647)

47' galvanized steel cable. 5/32" vinyl coated to 1/4" looped each end.



Singles Stick

(Item # 34753)

Deluxe all aluminum with cap and foot

