



LETTER OF TRANSMITTAL

PIPELINE CONTRACTORS

8600 Verbena St.
Commerce City, CO 80022
Office 303-289-4355
Fax 303-289-4353

ISSUED TO:

Owner ATTN: Owner Representative

DATE:

REGARDING:

TRANSMITTAL NO.:

Project JBS Job No 0210

We are issuing you under separate cover the following (via):

- Blue Prints
- Submittals
- Change Order
- Request for Information
- Copy of a letter
- Shop Drawings

-
-
-

#	Copies	Item Dated	Item #	Description
	1-Electronic		A-005	Sanitary Manholes

- For your bid
- For Approval
- As Requested
- Returned for Correction
- For Review and Comment
- For Pricing

-
-
-

Prints are loaned to you and are to be returned to us by: Date: _____

Bids are due on or before: Date: _____

COMMENTS

CC:

Amie Parent
 Amie Parent
 JBS Pipeline Contractors



Project Name: Trails at Crowfoot F2 (DR HORTON)

Location: Parker, CO

Contractor: JBS Pipeline Contractors

Date: 07/31/2019

Submitted by: Chris Hoganson

Phone: 303-867-6714

All product, materials, and design information provided by Forterra Precast Concepts, LLC is privileged and proprietary to Forterra Precast Concepts, LLC. In consideration of receiving said information the recipient thereof agrees that it and its employees, agents and consultants who may be made privy to said information shall be directed to hold and shall hold said information in the strictest confidence and shall treat it as privileged and proprietary to Forterra Precast Concepts, LLC. Access to said information shall be restricted to those who are required by their duties to be privy to such information.



CONCRETE MANHOLE PRODUCT CERTIFICATION

We hereby certify that the following precast concrete products are manufactured in accordance with the below referenced standard specifications and meet or exceed the minimum physical requirements established by these standards and the project specifications, most recent version.

- Precast manholes shall conform to ASTM C478 “Standard Specification for Precast Reinforced Concrete Manhole Sections”
- Steel reinforcing shall conform to ASTM C478. Rebar shall conform to ASTM A615 “Deformed and Plain Carbon-Steel Bars for Concrete Reinforcement” and Welded Wire Reinforcement shall conform to ASTM A1064 “Carbon-Steel Wire and Welded Wire Reinforcement, Plain and Deformed, for Concrete”
- Concrete shall conform to ASTM C478 and cement shall conform to ASTM C150 “Standard Specification for Portland Cement”
- Joints shall use rubber gaskets to conform to ASTM C443 “Joints for Concrete Pipe and Manholes, using Rubber Gaskets” or flexible joint sealant to conform to ASTM C990 “Joints for Concrete Pipe, Manholes, and Precast Box Sections, using Preformed Flexible Joints Sealants”
- Resilient Connectors (if applicable) shall conform to ASTM C923 “Resilient Connectors between Reinforced Concrete Manhole Structures, Pipe, and Laterals”
- Steps (if applicable) shall conform to ASTM C478.
- See attached product sheets and details for additional information.

All product, materials, and design information provided by Forterra Precast Concepts, LLC is privileged and proprietary to Forterra Precast Concepts, LLC. In consideration of receiving said information the recipient thereof agrees that it and its employees, agents and consultants who may be made privy to said information shall be directed to hold and shall hold said information in the strictest confidence and shall treat it as privileged and proprietary to Forterra Precast Concepts, LLC. Access to said information shall be restricted to those who are required by their duties to be privy to such information.

Ø48" ID MANHOLE COMPONENTS

CONCENTRIC

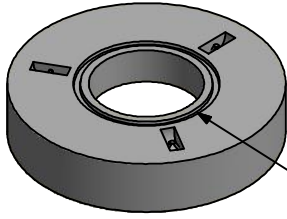

FLAT SLAB TOPS

HEIGHT	ACCESS	WEIGHT	BOTTOM JOINT
12-1/4"	24"	1650 LBS	BELL
12-1/4"	30"	1500 LBS	BELL
8"	24"	1500 LBS	BUTT
8"	30"	1350 LBS	BUTT

ECCENTRIC

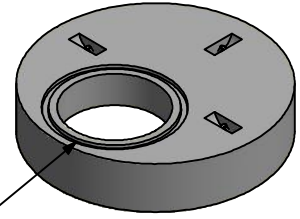

*INTERLOCK MATES WITH GRADE RINGS

CONCENTRIC



CONES

HEIGHT	ACCESS	WEIGHT	OPENING
24"	24"	1900 LBS	ECCENTRIC
30"	24"	2400 LBS	ECCENTRIC
30"	24"	2400 LBS	CONCENTRIC
36"	24"	2800 LBS	ECCENTRIC

ECCENTRIC

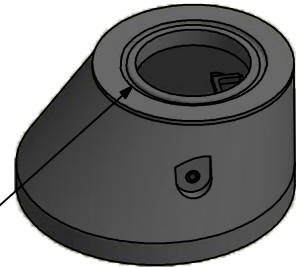

*INTERLOCK MATES WITH GRADE RINGS

JOINT DETAIL

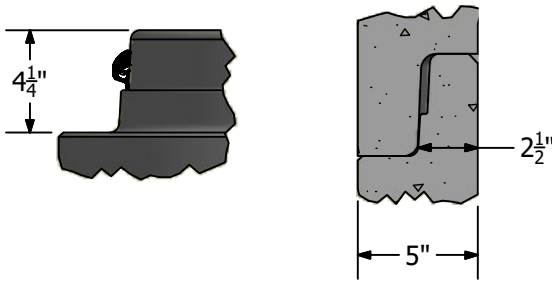

RISERS

HEIGHT	WEIGHT
Ø48" X 12"	1000 LBS
Ø48" X 24"	1900 LBS
Ø48" X 36"	2750 LBS
Ø48" X 48"	3600 LBS

BASES

- AVAILABLE WITH MONOLITHIC CAST INVERT CHANNEL
- CUSTOM INVERT CHANNELS AVAILABLE
- CUSTOM HOLE SIZES AVAILABLE
- BASE HEIGHTS AVAILABLE: 24" - 54"
- SANITARY BASES WITH INVERTS ADD ABOUT 2000 LBS

STANDARD BASE SIZES

HEIGHT	BLANK BASE NO INVERT NO HOLES
24"	6200 LBS
27"	6550 LBS
30"	6950 LBS
33"	7300 LBS
36"	7650 LBS
39"	8050 LBS
41"	8300 LBS
44"	8650 LBS
45"	8750 LBS
47"	9000 LBS
48"	9150 LBS
50"	9400 LBS
51"	9500 LBS
54"	9900 LBS



NOTES:

- MANHOLE COMPONENTS MEET ASTM C478 SPECIFICATIONS
- MANHOLE COMPONENTS SUITABLE FOR HS-20 LOADING
- JOINTS MEET ASTM C443
- FLEXIBLE CONNECTORS MEET ASTM C923
- ALL WEIGHTS ARE APPROXIMATE
- CAST IRON RING & COVER AND GRADE RINGS AVAILABLE



9405 ALTON COURT
HENDERSON, CO 80640
303-853-8053

GRADE RING COMPONENTS

INTERLOCKING



24" ID GRADE RINGS

HEIGHT	WEIGHT
2"	80 LBS
3"	120 LBS
4"	160 LBS
6"	240 LBS

- AVAILABLE WITH OR WITHOUT LOCKING GROOVE

FLAT JOINT



INTERLOCKING



30" ID GRADE RINGS

HEIGHT	WEIGHT
2"	95 LBS
3"	140 LBS
4"	190 LBS
6"	285 LBS

- AVAILABLE WITH OR WITHOUT LOCKING GROOVE

FLAT JOINT



INTERLOCKING



36" ID GRADE RINGS

HEIGHT	WEIGHT
2"	110 LBS
3"	165 LBS
4"	220 LBS
6"	335 LBS
12"	670 LBS

- AVAILABLE WITH OR WITHOUT LOCKING GROOVE

FLAT JOINT

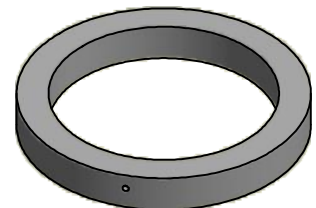

INTERLOCKING DETAIL

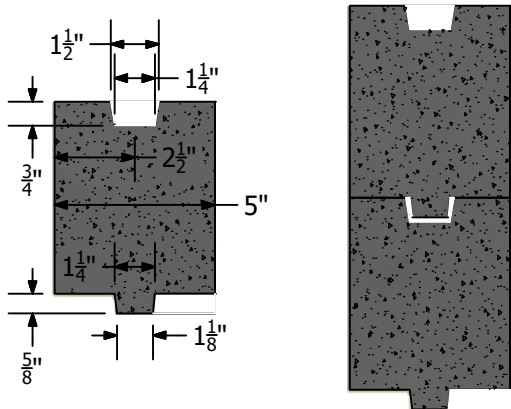

SEALING OPTIONS

1. BUTYL SEALANT
2. TROWELABLE BUTYL SEALANT
3. MORTAR
4. NO SEALANT APPLIED



NOTES:

- GRADE RINGS MEET ASTM C478
- ALL WEIGHTS ARE APPROXIMATE
- ALL GRADE RINGS HAVE 5" WALL THICKNESS
- GRADE RINGS MATE WITH OTHER GRADE RINGS, CONES, AND FLAT SLAB TOPS



9405 ALTON COURT
 HENDERSON, CO 80640
 303-853-8053



TSS Series

Tylox® SuperSeal™ Pre-lubricated Profile Gaskets for Single Offset Joints on Concrete Manhole

*Say good-bye to the lube bucket and brush.
Say hello to fast, clean, simple installation.*

The unique design of the Tylox® SuperSeal™ manhole gasket is bringing a cost-saving revolution to the field of concrete manhole gasketing and installation.

- **Requires no field lubrication.** The Tylox® SuperSeal™ gasket has a layer of silicone lubricant installed on the inner surface of the tube during the manufacturing process; saving you time and money on the job-site.
- **Elimination of unsafe installation practices.** Since the Tylox® SuperSeal™ manhole gasket requires no lubrication, the unsafe practice of standing beneath a suspended riser section in order to lubricate the bell I.D. is no longer required.
- **Self-Contained Lubricant.** Sealed within the tube, the lubricant is impervious to mud, dirt and debris. If you drop it in the trench, simply wipe the gasket surface clean and you're ready to install. No special handling is required.
- **No equalization required.** Due to the reduced gasket stretch requirement of the unique lamelle/rolling-tube design, the Tylox® SuperSeal™ gasket requires no equalization after installation. A quick and easy installation means you save even more time and money.
- **No gasket "roll" or "twist".** Another benefit of the unique lamelle/rolling-tube design is the drastic reduction in insertion forces, virtually eliminating the gasket "roll" and "twist" associated with o-ring and standard profile gaskets.
- **Self-Centering.** The manhole bell is self-centered on the spigot due to the forces generated as the tube rolls into the annular space during the homing process.



Tylox® SuperSeal™ gaskets are available for all common combinations of annular and total annular spaces, and can be manufactured to suit any manhole size.

Tylox® SuperSeal™ manhole gaskets are available in a variety of rubber compounds, to meet or exceed the material requirements of ASTM C443, ASTM C1619, California Greenbook, and CSA A-257.3.

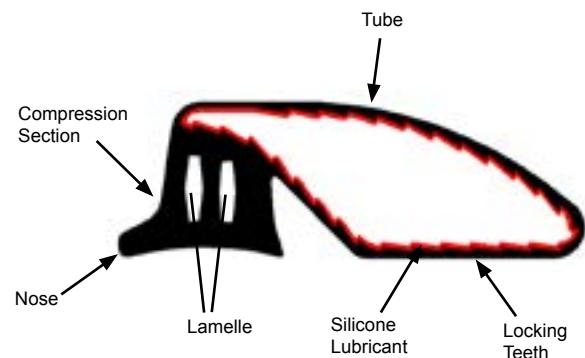

**Making Infrastructure Watertight Today
for a Greener, Sustainable Tomorrow**

Available Models					
Model	Body Height	Body Width	Total Width	To Suit *	
				Total	Small
165	0.682	0.791	1.780	0.446	0.146
166**	0.680	0.780	1.615	0.446	0.094
170	0.682	0.808	1.290	0.446	0.126
175	0.697	0.833	1.398	0.446	0.146
176**	0.735	0.825	1.520	0.446	0.094
200L	0.885	1.049	2.549	0.500	0.175
225	0.914	1.085	2.787	0.525	0.175
226**	0.850	1.048	2.318	0.525	0.094

* For informational purposes only. Consult your Hamilton Kent representative for sizing to suit your specific joint details.
** These models do not have locking teeth.

Materials and Identification

Tylox® SuperSeal™ manhole gaskets are manufactured from a variety of synthetic rubber compounds to meet the material requirements of ASTM C443 and C1619, and CSA A257.3. The applicable specification(s) and useage mode for a particular gasket are identified by a colored stripe around the periphery of the gasket:

Standard

ASTM C443, C1619 Class C and CSA A257.3 White Stripe
California Greenbook Green Stripe

Oil-Resistant

ASTM C443, C1619 Class D and CSA A257.3 - Nitrile rubber Orange Stripe
ASTM C443, C1619 Class D and CSA A257.3 - Neoprene rubber Yellow Stripe

The above listing covers the standard, North American, specifications. Gaskets materials are available to meet many other specifications. Please consult your Hamilton Kent representative regarding materials to meet your particular specifications.

Pressure Rating

Tylox® SuperSeal™ gaskets are suitable for use in systems with up to 13 psig (30 ft Head) pressure requirements.

Higher head pressures have been obtained with certain

joint designs. Please consult your local Hamilton Kent Representative for gasket selection to meet your specific requirements.

Installation

1. Ensure that bell and spigot are free from cracks, chips, or other defects.
2. Brush loose dirt, debris and foreign material from the inside surface of the bell, the spigot and the gasket.
3. Stretch gasket around the spigot, with the nose against the step, and the tube laying flat against the spigot.
4. Do not lubricate the gasket or joint as this could adversely affect the performance of the gasket and the joint.
5. Align the spigot with the bell, ensuring that the gasket is in contact with the bell around the complete periphery, then allow the manhole section to home under its own weight.

The homing process will cause the lubricated tube to roll over the compression section, allowing the manhole section to slide downward.

Once fully homed, the compression section seals the total annular space and the rolling tube comes to rest within the small annular space, acting as a cushion against side loads.

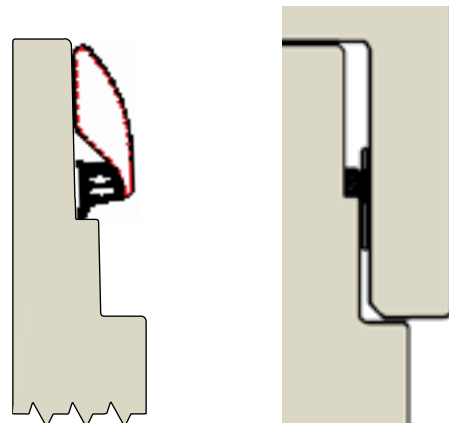

TEL: (800) 268 8479

FAX: (888) 674 6960

WEB: www.hamiltonkent.com

E-MAIL: sales@hamiltonkent.com

Lit_TSS_Manhole_English_R7

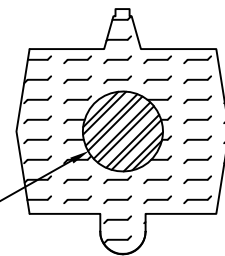
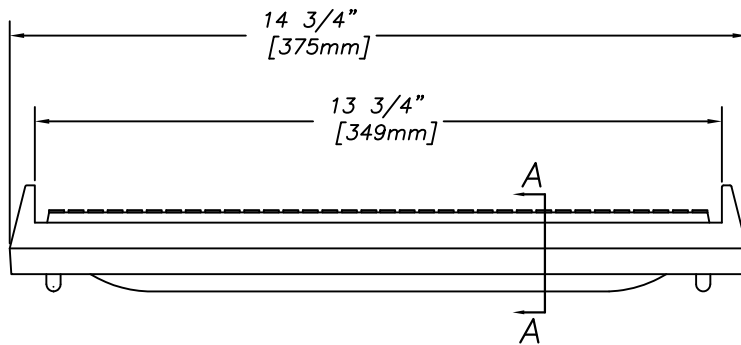
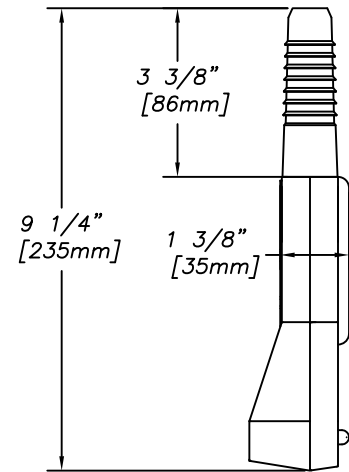
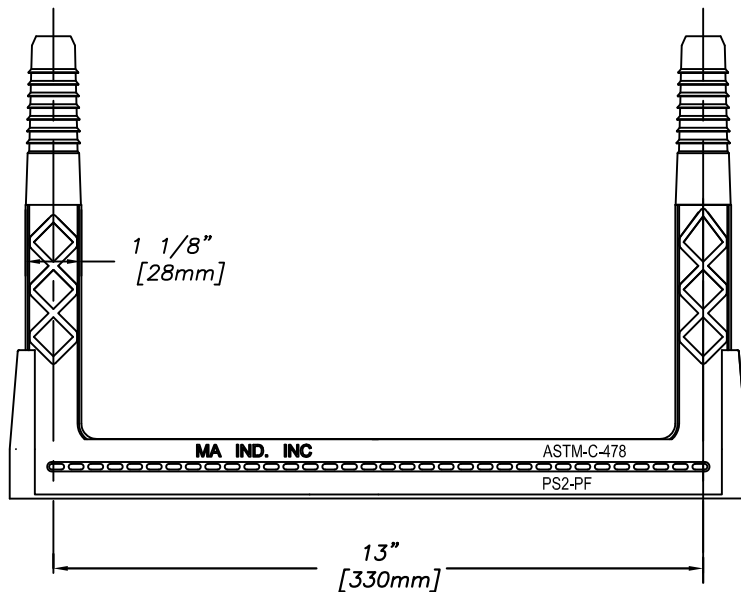

Copolymer Polypropylene Plastic

13mm
1/2" **GRADE 60 STEEL REINFORCEMENT**

SECTION-A

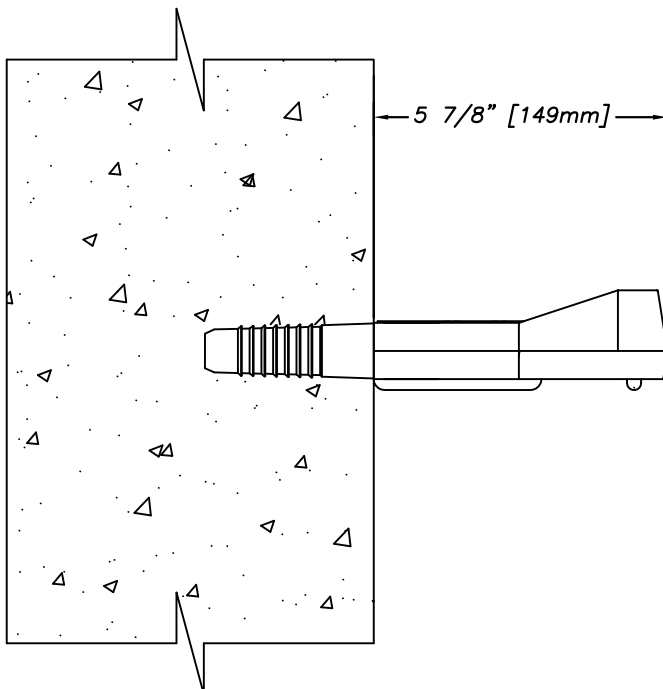

**MEETS: ASTM C-478
ASTM D-4101
ASTM A-615
AASHTO M-199**

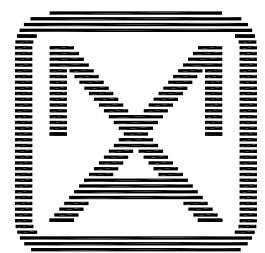

M . A . I N D U S T R I E S , I N C .

2420Z2 Frame

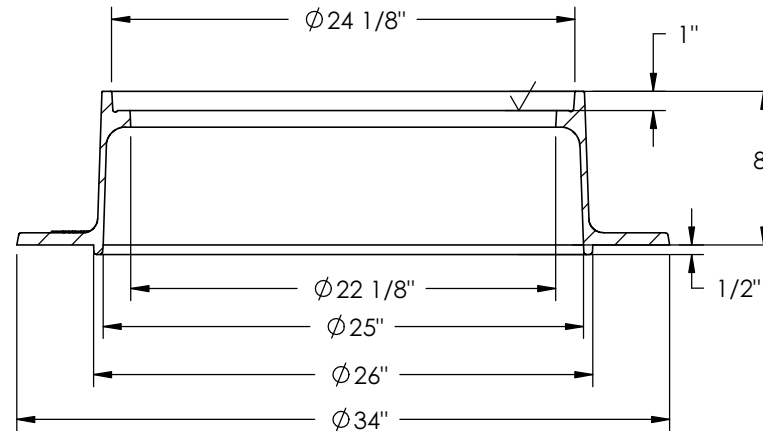
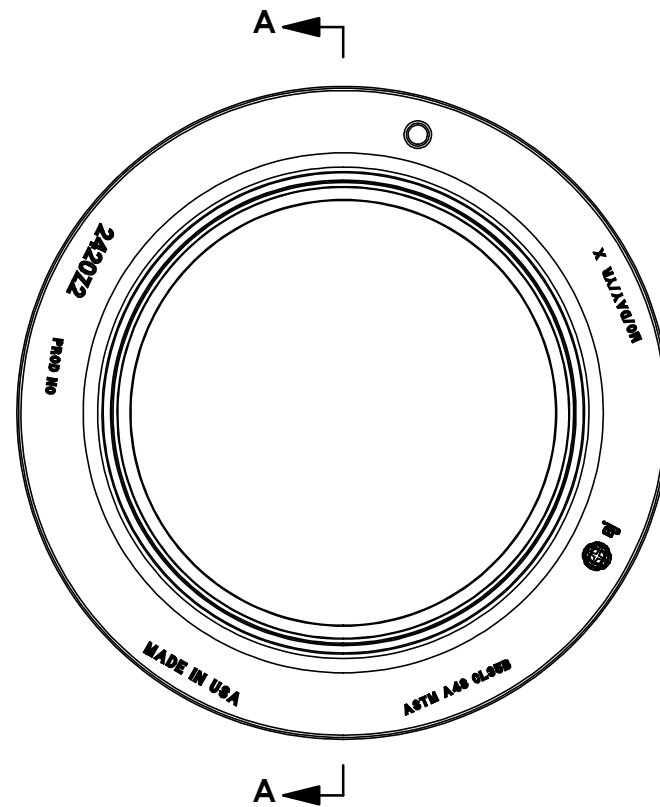

SECTION A-A
SCALE 1 : 10

Product Number

00242013

Design Features

- Materials
Gray Iron (CL35B)
- Design Load
Heavy Duty
- Open Area
n/a
- Coating
Undipped
- √ Designates Machined Surface

Certification

- ASTM A48
-
-
- Country of Origin: USA

Drawing Revision

09/09/2008 Designer: DEW
10/29/2014 Revised By: DJH

Disclaimer

Weights (lbs/kg), dimensions (inches/mm) and drawings provided for your guidance. We reserve the right to modify specifications without prior notice.

CONFIDENTIAL: This drawing is the property of EJ Group, Inc. and embodies confidential information, registered marks, patents, trade secret information, and/or know how that is the property of EJ Group, Inc. Copyright © 2012 EJ Group, Inc. All rights reserved.

Contact

800 626 4653
ejco.com

ConSeal™ CS-102

Butyl Rubber Sealant



Butyl Rubber Sealant for All Precast Concrete Structures - Meets ASTM C-990

Applications

For concrete joints in: Manholes, Concrete Pipe, Vaults, Box Culverts, Septic Tanks, and Vertical Panel Structures. **Not intended for use in expansion joints or joints that move.**

Sealing Properties

- Provides permanently flexible watertight joints.
- Low to high temperature workability: 30°F to 120°F (-1°C to +48°C)
- Rugged service temperature: -30°F to +200°F (-34°C to +93°C)
- Excellent chemical and mechanical adhesion to clean dry surfaces.
- Greater cohesive and adhesive strengths.
- Sealed joints will not shrink, harden or oxidize upon aging.
- Controlled flow resistance for application ease.
- No priming normally necessary. When confronted with difficult installation conditions, such as wet concrete or temperatures below 40°F (4°C), priming the concrete will improve the bonding action. Consult Concrete Sealants for the proper primer to meet your application.

Hydrostatic Strength

ConSeal CS-102 meets the hydrostatic performance requirement as set forth in ASTM C-990 section 10.1 (Performance requirement: 10psi for 10 minutes in straight alignment – in plant, quality control test for joint materials.)

Specifications

ConSeal CS-102 meets or exceeds all of the requirements of Federal Specification SS-S-210 (210-A), AASHTO M-198B, and ASTM C-990-91.

Physical Properties

Description

Description	Spec	Required	CS-102
Color			Black
Specific Gravity, 77°F	ASTM D71	1.15-1.50	1.25
Ductility, 77°F	ASTM D113	5.0 min.	10
Penetration, cone 77°F (25°C), 150 gm, 5 sec.	ASTM D217	50-100 mm	55-60 mm
Penetration, cone 32°F (0°C), 150 gm, 5 sec.	ASTM D217	40 mm min.	40-65 mm
Flash Point, C.O.C., °F	ASTM D92	350°F min.	450°F
Fire Point, C.O.C., °F	ASTM D92	375°F min.	475°F

Don't Just Seal It, ConSeal It!

© 2013 Concrete Sealants, Inc.

Concrete Sealants, Inc. 9325 State Route 201 ■ Tipp City, OH 45371 ■ P.O. Box 176 ■ New Carlisle, OH 45344
P. 937.845.8776 **F.** 937.845.3587 **Toll Free** 800.332.7325 ■ www.conseal.com



ConSeal™ CS-102

Butyl Rubber Sealant



Butyl Rubber Sealant for All Precast Concrete Structures - Meets ASTM C-990

Chemical Composition

Description

	Spec	Required	CS-102
Hydrocarbon plastic content % by weight	ASTM D297	50% min.	51%
Inert mineral filler % by weight	AASHTO T111	30% min.	35%
Volatile Mater % by weight	ASTM D6	2% max.	1.2%
Non-extractable, carbon-based material			12.8%
Recycled Content, % by weight			
Post Consumer:			8.41%
Post Industrial:			10.85%

Immersion Testing

30-Day Immersion Testing: No visible deterioration when tested in 5% Caustic Potash, 5% Hydrochloric Acid, 5% Sulfuric Acid, and 5% saturated Hydrogen Sulfide.

One Year Immersion Testing: No visible deterioration when tested in 5% Formaldehyde, 5% Formic Acid, 5% Sulfuric Acid, 5% Hydrochloric Acid, 5% Sodium Hydroxide, 5% Hydrogen Sulfide, and 5% Potassium Hydroxide.

Limited Warranty

This information is presented in good faith, but we cannot anticipate all conditions under which this information and our products, or the products of other manufactures in combination with our products, may be used. We accept no responsibility for results obtained by the application of this information or the safety and suitability of our products, either alone or in combination with other products. Users are advised to make their own tests to determine the safety and suitability of each such product or product combinations for their own purposes. It is the **users' responsibility** to satisfy himself as to the suitability and completeness of such information for this own particular use. We sell this product without warranty, and buyers and users assume all responsibility and liability for loss or damage arising from the handling and use of this product, whether used alone or in combination with other products.

Don't Just Seal It, ConSeal It!

© 2013 Concrete Sealants, Inc.

Concrete Sealants, Inc. 9325 State Route 201 ■ Tipp City, OH 45371 ■ P.O. Box 176 ■ New Carlisle, OH 45344
P. 937.845.8776 **F.** 937.845.3587 **Toll Free** 800.332.7325 ■ www.conseal.com



SANITARY

2400A Cover

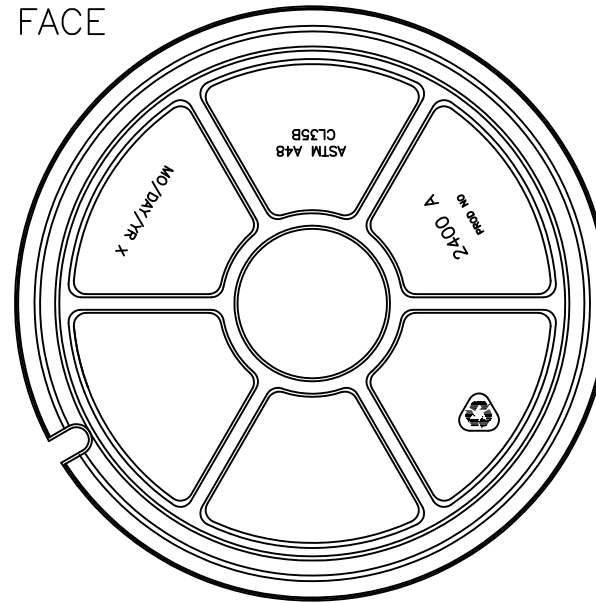
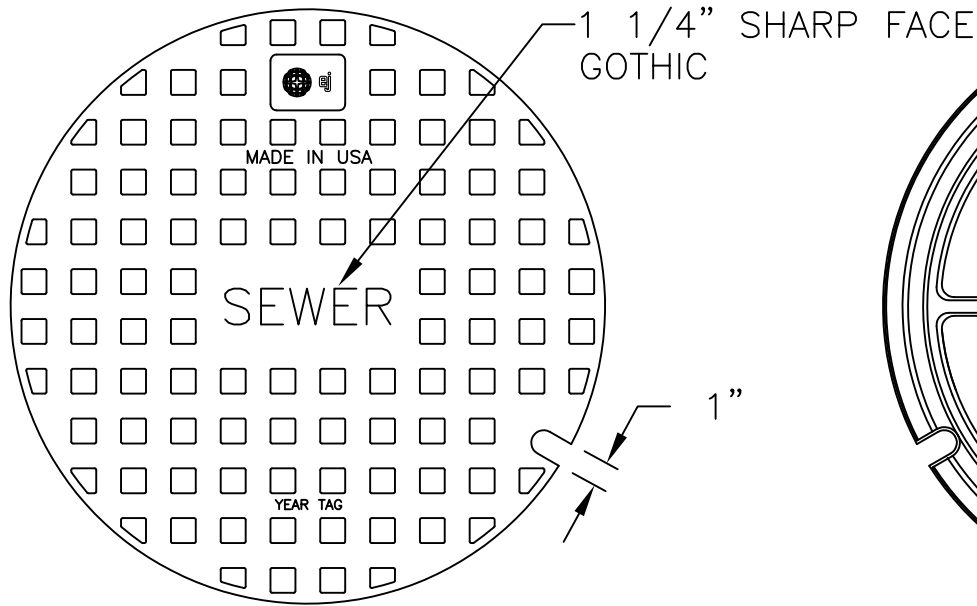

COVER BACK

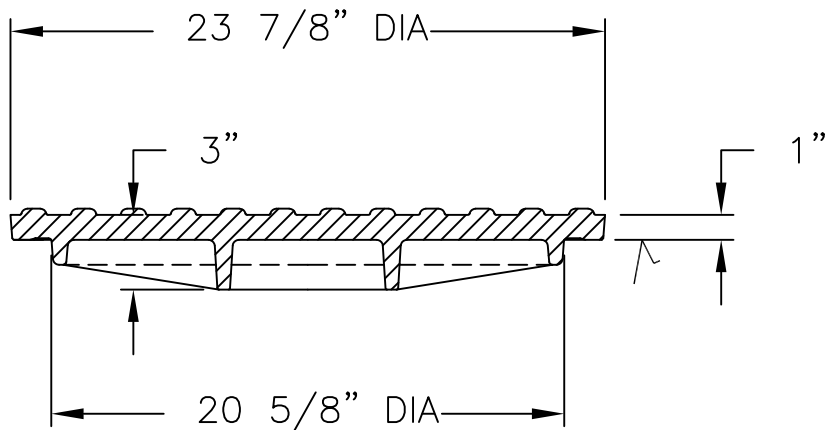

SECTION

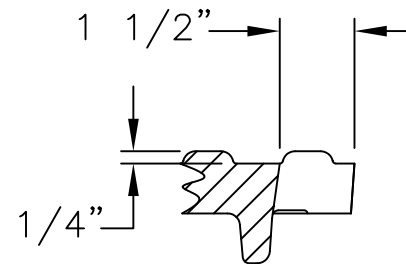

PICKSLOT DETAIL

Product Number

00240023

Design Features

- Materials
Gray Iron (CL35B)
- Design Load
Heavy Duty
- Open Area
n/a
- Coating
Undipped
- ✓ Designates Machined Surface

Certification

- ASTM A48
-
-
- Country of Origin: USA

Drawing Revision

3/10/2001 Designer: JJJ
6/10/2013 Revised By: DAE

Disclaimer

Weights (lbs./kg) dimensions (inches/mm) and drawings provided for your guidance. We reserve the right to modify specifications without prior notice.

CONFIDENTIAL: This drawing is the property of EJ GROUP, Inc., and embodies confidential information, registered marks, patents, trade secret information, and/or know how that is the property of EJ GROUP, Inc. Copyright © 2012 EJ GROUP, Inc. All rights reserved.

Contact

800 626 4653
ejco.com



9455 Boston Ct.
 Henderson, CO 80640
 Phone: (303) 853-8053
 Fax:
 www.ForterraBP.com

Contractor: JBS Pipeline Contractors, CO
Project: Trails at Crowfoot F2 (DR HORTON)
Location: CO Parker
Order Nbr: 9419134MH1
Remarks: ASTM C478

Sanitary Sewer
48" (I.D.) Manhole
SA TC-SSMH-6
 Date: 07/31/2019 Revised: 07/31/2019
 Plant: 155 Henderson Precast
 Coordinator: Chris Hoganson

Design Build Height	
Top of Casting	+ 6043.63
Outlet Invert	- 6029.34
Wall Thk/Inv Adj	+ .14
Design Height	= 14.43
Casting/Adj Ring	- .88
Manhole Hgt	= 13.56

Stack Build Height	
Casting	+ .71
Adjusting Ring	+ .17
Cone	+ 2.50
Riser	+ 11.00
Base Thickness	+ .00
Outside Height	= 14.38

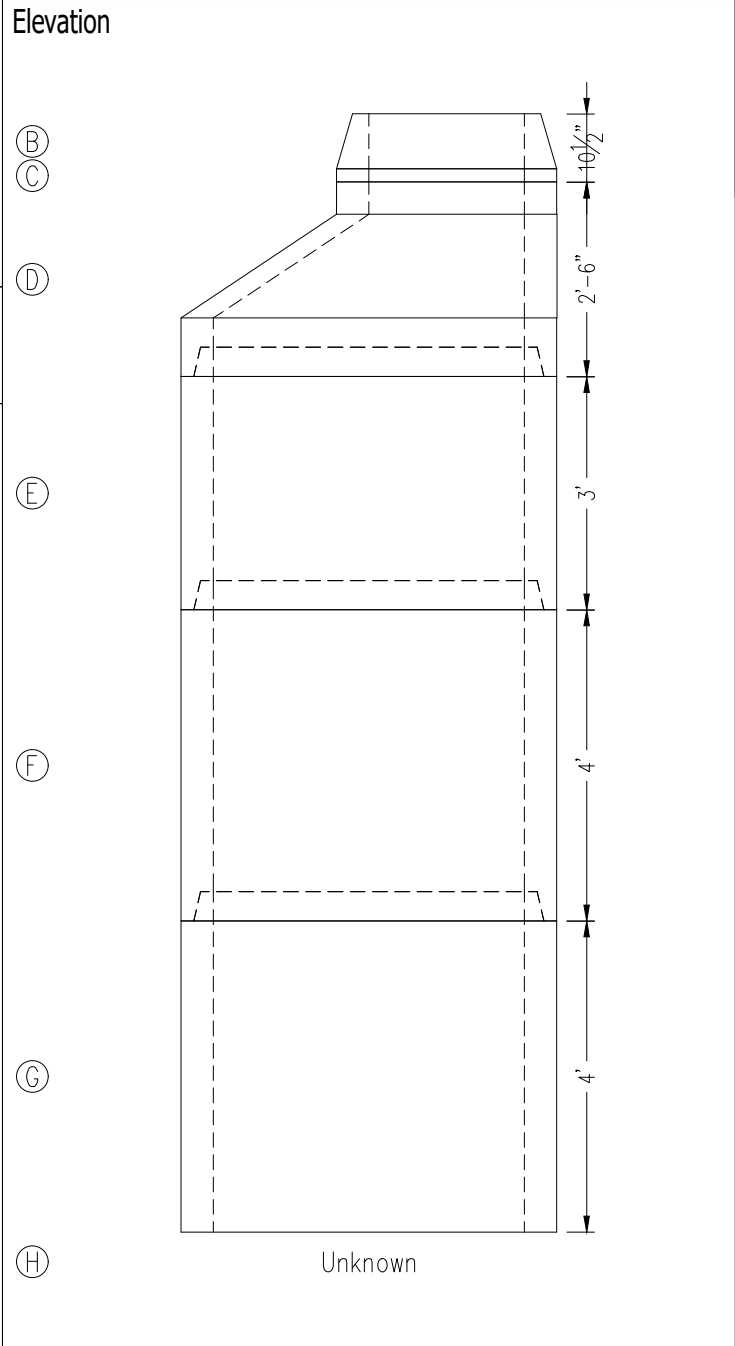

Opening Schedule								(HF=Hole Former, D0=Dig Out)	
ID	Pipe Size	Invert	Pipe Up	Opening/ O.D.	Connector	Top of Hole Up	C-Line Hole Up	Btm of Hole Up	

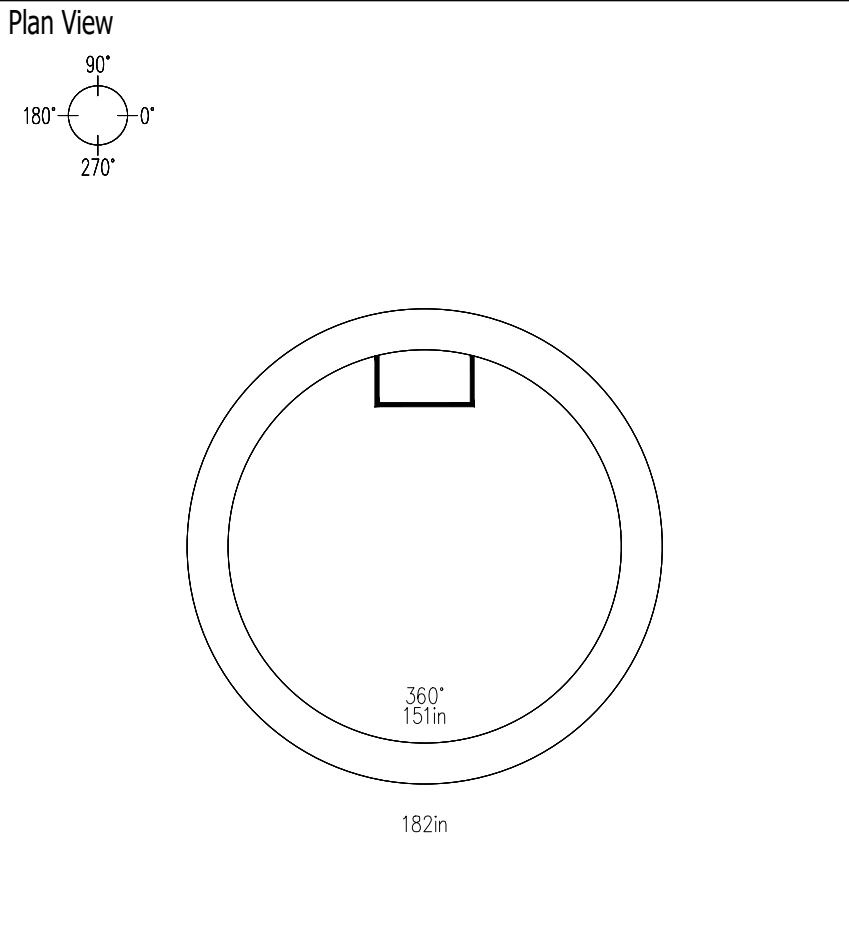

Notes
 PIPE INVERT ELEVATION = TOP OF CAST IN PLACE BASE (4" ABOVE TOP OF OD OF HIGHEST PIPE).
 VAC TEST REQ'D

Steps: 12" On Center 90°

Item List					
ID	Description	Product No	Hgt	Qty	Weight
A	EJ 2400A Cover Sewer Knobby	9000100000660	.00	1	148
B	EJ 2420Z2 Ring 8"	9000100000713	.71	1	149
C	24x2 Interlock Adjusting Ring	909010024020A	.17	1	80
D	48x2.5 24 Ecc Cone PHS S	204809V2100000025	2.50	1	2,370
E	48x3.0 BBL PHS S	204801V0100000030	3.00	1	2,610
F	48x4.0 BBL PHS S	204801V0100000040	4.00	1	3,480
G	48x4.0 BBL FB PHS S	204801V5100000040	4.00	1	3,480
H	Unknown		.00	1	0
Total Weight (lbs)					12,317

Misc. Items	
Description	Qty
Gasket PHS 48 inch SSMH	3
Joint Seal CS102 1X14.5	1

Production Use	
Mfg. Date:	
Ship Date:	
Frame/Ring:	
Grate/Cover:	
PREPOUR:	
POSTPOUR:	



9455 Boston Ct.
Henderson, CO 80640
Phone: (303) 853-8053
Fax:
www.ForterraBP.com

Contractor: JBS Pipeline Contractors, CO
Project: Trails at Crowfoot F2 (DR HORTON)
Location: CO Parker
Order Nbr: 9419134MH1
Remarks: ASTM C478

Sanitary Sewer
48" (I.D.) Manhole
SA TC-SSMH-5
Date: 07/31/2019 Revised: 07/31/2019
Plant: 155 Henderson Precast
Coordinator: Chris Hoganson

Design Build Height	
Top of Casting	+ 6046.53
Outlet Invert	- 6027.96
Wall Thk/Inv Adj	+ .14
Design Height	= 18.71
Casting/Adj Ring	- 1.21
Manhole Hgt	= 17.50

Stack Build Height	
Casting	+ .71
Adjusting Ring	+ .50
Cone	+ 2.50
Cover Slab	+ 1.00
Riser	+ 14.00
Base Thickness	+ .00
Outside Height	= 18.71

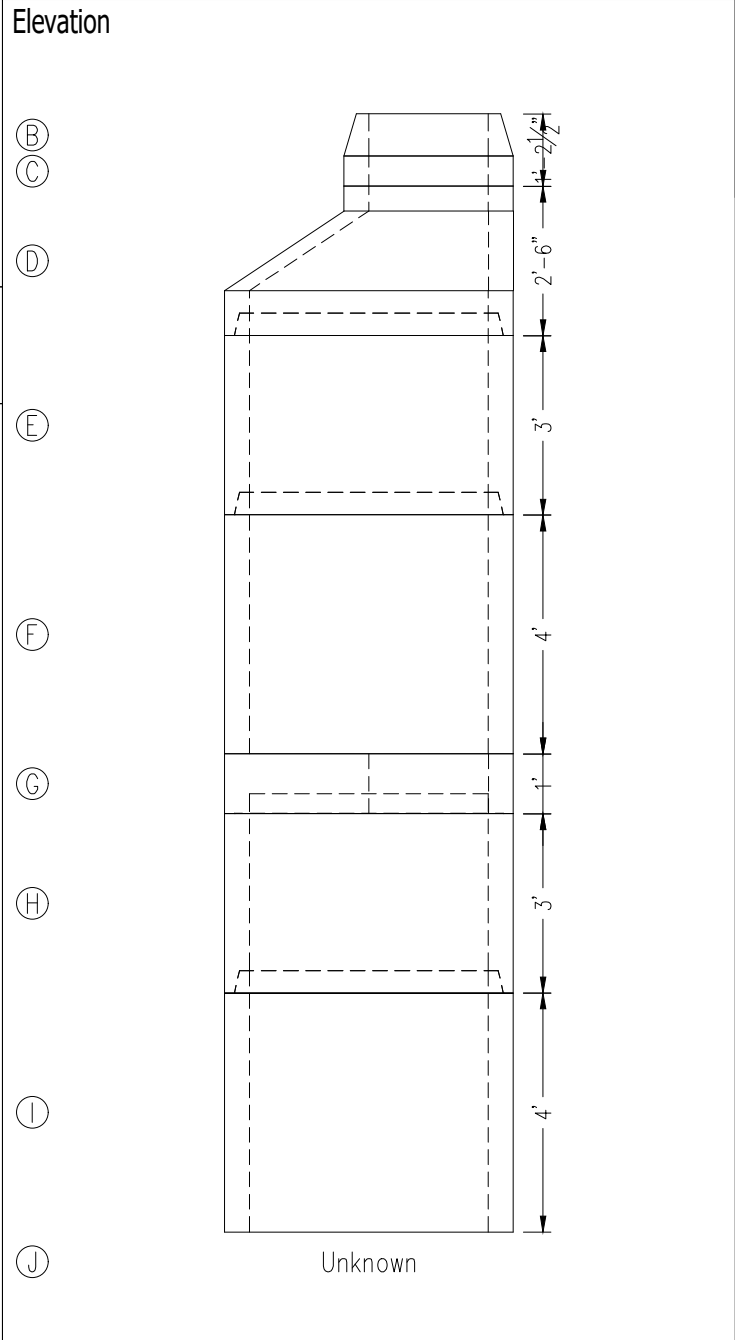

Opening Schedule (HF=Hole Former, D0=Dig Out)								
ID	Pipe Size	Invert	Pipe Up	Opening/ O.D.	Connector	Top of Hole Up	C-Line Hole Up	Btm of Hole Up

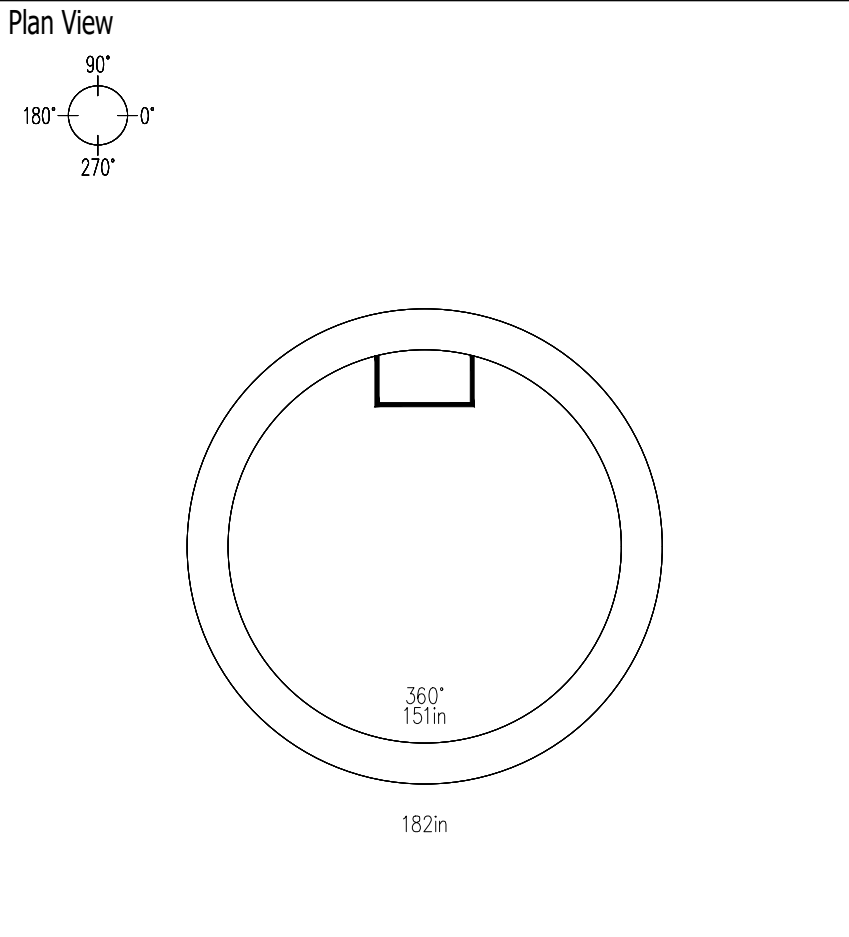

Notes
PIPE INVERT ELEVATION = TOP OF CAST IN PLACE BASE (4" ABOVE TOP OF OD OF HIGHEST PIPE).
VAC TEST REQ'D

Steps: 12" On Center 90°

ID	Description	Product No	Hgt	Qty	Weight
A	EJ 2400A Cover Sewer Knobby	9000100000660	.00	1	148
B	EJ 2420Z2 Ring 8"	9000100000713	.71	1	149
C	24x6 Interlock Adjusting Ring	909010024060A	.50	1	240
D	48x2.5 24 Ecc Cone PHS S	204809V2100000025	2.50	1	2,370
E	48x3.0 BBL PHS S	204801V0100000030	3.00	1	2,610
F	48x4.0 BBL FB PHS S	204801V5100000040	4.00	1	3,480
G	48x8 Cvr 24H Ecc PHS	2204808_V0210	1.00	1	1,521
H	48x3.0 BBL PHS S	204801V0100000030	3.00	1	2,610
I	48x4.0 BBL FB PHS S	204801V5100000040	4.00	1	3,480
J	Unknown		.00	1	0
Total Weight (lbs)					16,608

Misc. Items	
Description	Qty
Gasket PHS 48 inch SSMH	5
Joint Seal CS102 1X14.5	2

Production Use	
Mfg. Date:	
Ship Date:	
Frame/Ring:	
Grate/Cover:	
PREPOUR:	
POSTPOUR:	

Design Build Height	
Top of Casting	+ 6035.87
Outlet Invert	- 6023.59
Wall Thk/Inv Adj	+ .14
Design Height	= 12.42
Casting/Adj Ring	- .88
Manhole Hgt	= 11.54

Stack Build Height	
Casting	+ .71
Adjusting Ring	+ .17
Cone	+ 2.50
Riser	+ 9.00
Base Thickness	+ .00
Outside Height	= 12.38

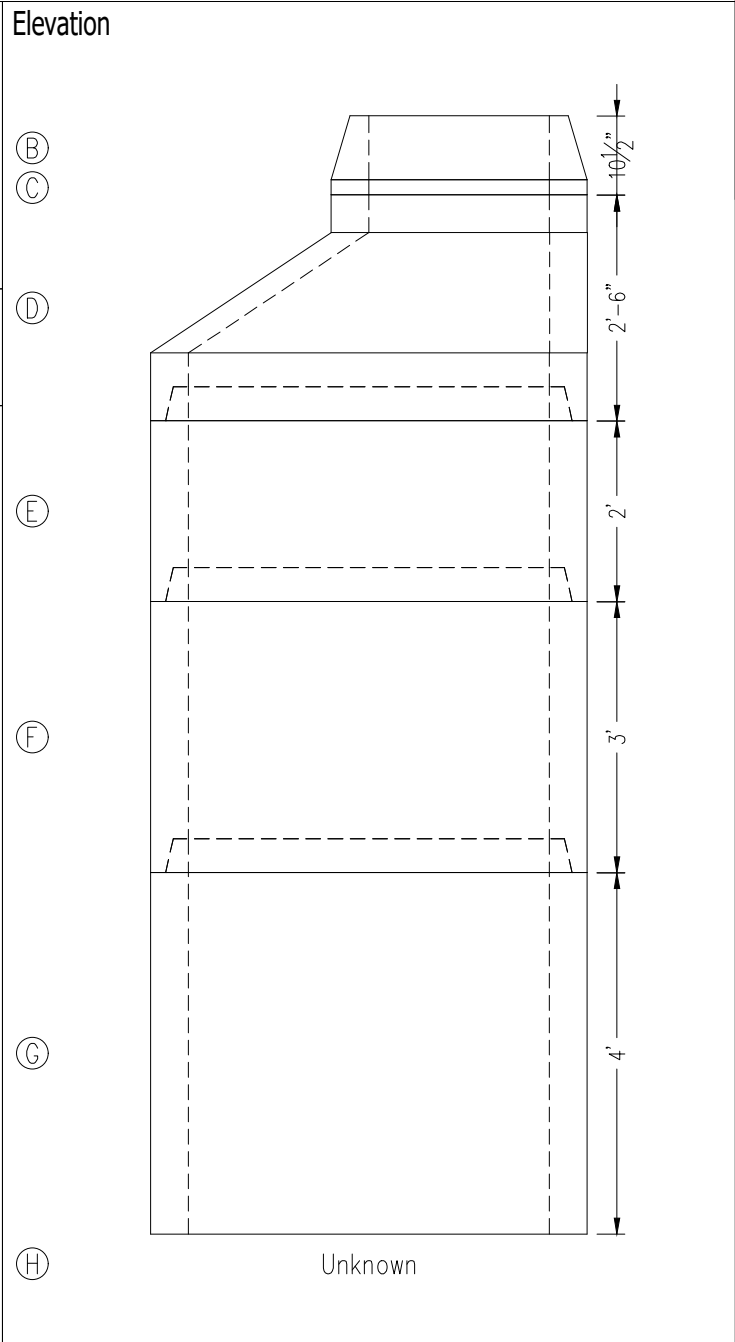

Opening Schedule								
ID	Pipe Size	Invert	Pipe Up	Opening/ O.D.	Connector	Top of Hole Up	C-Line Hole Up	Btm of Hole Up
(HF=Hole Former, DO=Dig Out)								

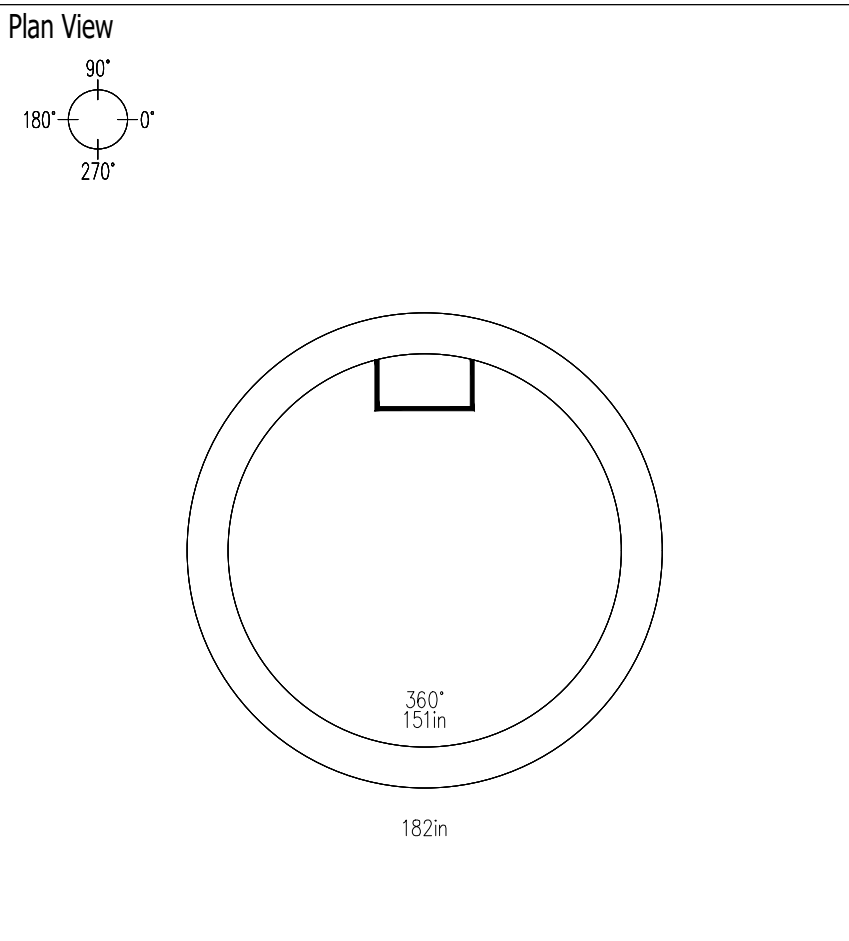

Notes
PIPE INVERT ELEVATION = TOP OF CAST IN PLACE BASE (4" ABOVE TOP OF OD OF HIGHEST PIPE).
VAC TEST REQ'D

Steps: 12" On Center 90°

ID	Description	Product No	Hgt	Qty	Weight
A	EJ 2400A Cover Sewer Knobby	9000100000660	.00	1	148
B	EJ 2420Z2 Ring 8"	9000100000713	.71	1	149
C	24x2 Interlock Adjusting Ring	909010024020A	.17	1	80
D	48x2.5 24 Ecc Cone PHS S	204809V2100000025	2.50	1	2,370
E	48x2.0 BBL PHS S	204801V0100000020	2.00	1	1,740
F	48x3.0 BBL PHS S	204801V0100000030	3.00	1	2,610
G	48x4.0 BBL FB PHS S	204801V5100000040	4.00	1	3,480
H	Unknown		.00	1	0
Total Weight (lbs)					10,577

Misc. Items	
Description	Qty
Gasket PHS 48 inch SSMH	3
Joint Seal CS102 1X14.5	1

Production Use	
Mfg. Date:	
Ship Date:	
Frame/Ring:	
Grate/Cover:	
PREPOUR:	
POSTPOUR:	



9455 Boston Ct.
Henderson, CO 80640
Phone: (303) 853-8053
Fax:
www.ForterraBP.com

Contractor: JBS Pipeline Contractors, CO
Project: Trails at Crowfoot F2 (DR HORTON)
Location: CO Parker
Order Nbr: 9419134MH1
Remarks: ASTM C478

Sanitary Sewer
48" (I.D.) Manhole
SA TC- SSMH-28
Date: 07/31/2019
Plant: 155 Henderson Precast
Coordinator: Chris Hoganson

Design Build Height		Stack Build Height	
Top of Casting	+ 6040.44	Casting	+ .71
Outlet Invert	- 6029.44	Adjusting Ring	+ .42
Wall Thk/Inv Adj	+ .14	Cone	+ 3.00
Design Height	= 11.14	Riser	+ 7.00
Casting/Adj Ring	- 1.13	Base Thickness	+ .00
Manhole Hgt	= 10.02	Outside Height	= 11.13

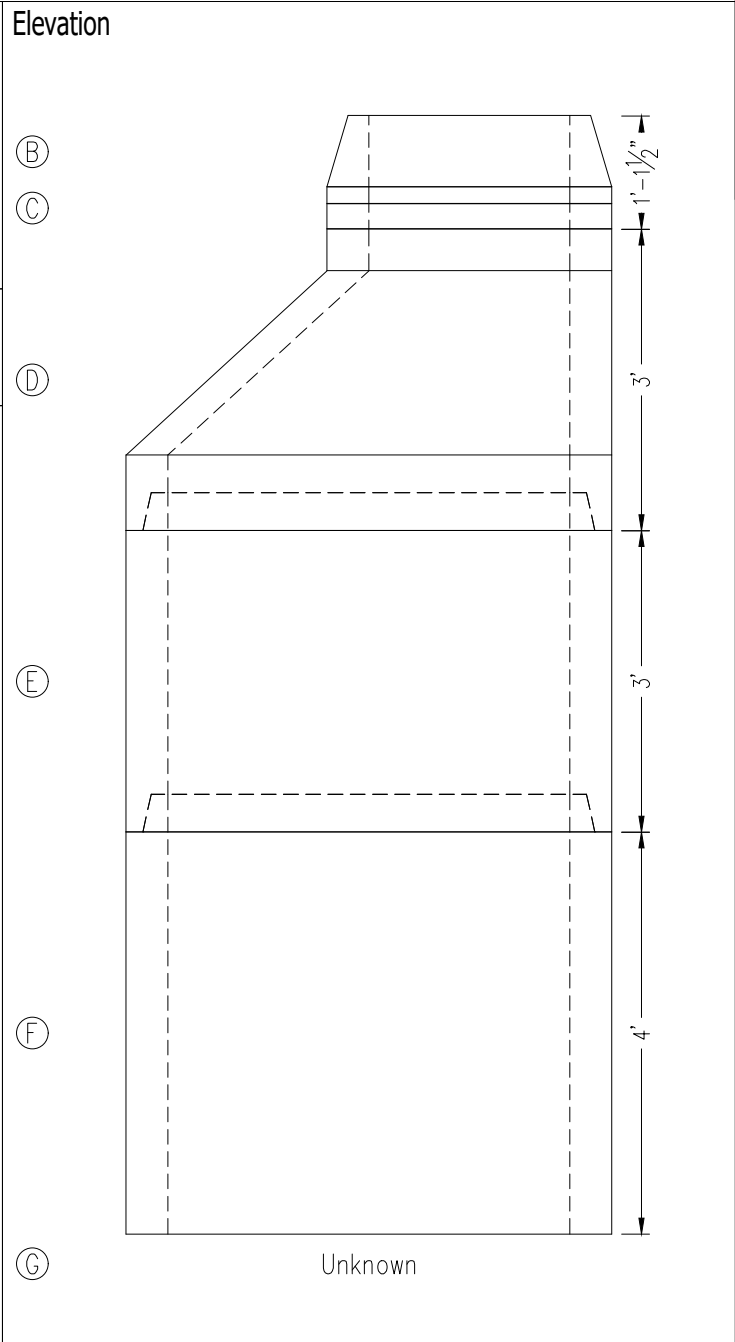

Opening Schedule (HF=Hole Former, DO=Dig Out)

ID	Pipe Size	Invert	Pipe Up	Opening/ O.D.	Connector	Top of Hole Up	C-Line Hole Up	Btm of Hole Up

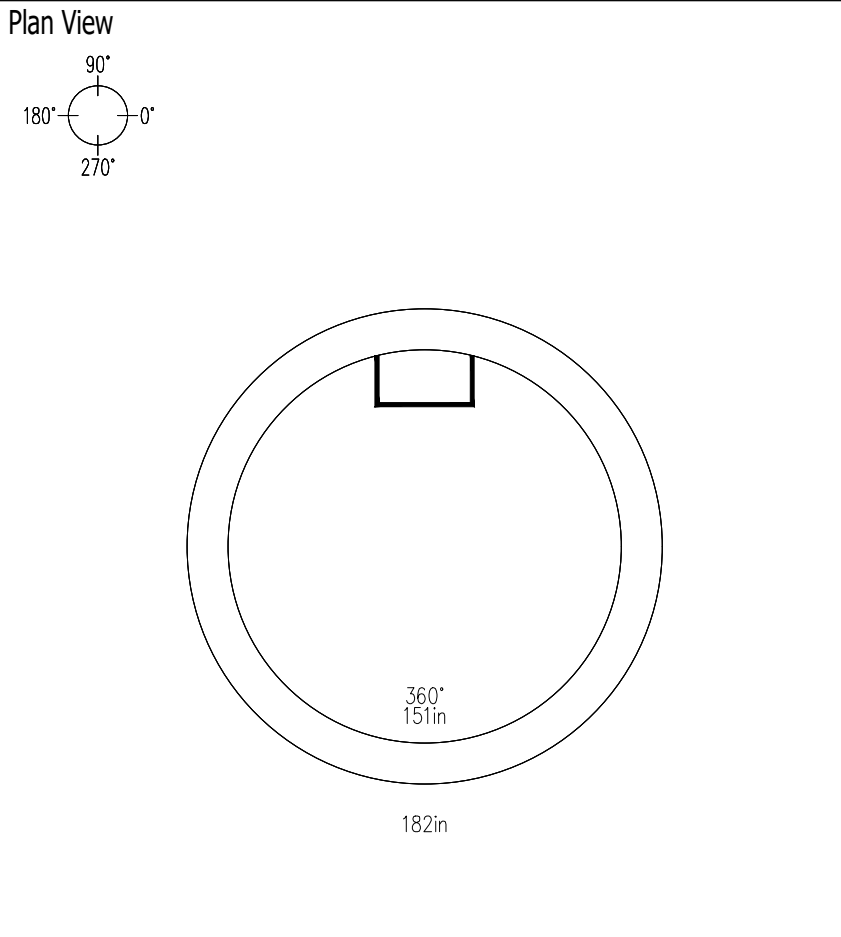

Notes
PIPE INVERT ELEVATION = TOP OF CAST IN PLACE BASE (4" ABOVE TOP OF OD OF HIGHEST PIPE).
VAC TEST REQ'D

Steps: 12" On Center 90°

ID	Description	Product No	Hgt	Qty	Weight
A	EJ 2400A Cover Sewer Knobby	9000100000660	.00	1	148
B	EJ 2420Z2 Ring 8"	9000100000713	.71	1	149
C	24x2 Interlock Adjusting Ring	909010024020A	.17	1	80
C	24x3 Interlock Adjusting Ring	909010024030A	.25	1	120
D	48x3.0 24 Ecc Cone PHS S	204809V2100000030	3.00	1	2,900
E	48x3.0 BBL PHS S	204801V0100000030	3.00	1	2,610
F	48x4.0 BBL FB PHS S	204801V5100000040	4.00	1	3,480
G	Unknown		.00	1	0
Total Weight (lbs)					9,487

Misc. Items	
Description	Qty
Gasket PHS 48 inch SSMH	2
Joint Seal CS102 1X14.5	1

Production Use	
Mfg. Date:	
Ship Date:	
Frame/Ring:	
Grate/Cover:	
PREPOUR:	
POSTPOUR:	



9455 Boston Ct.
Henderson, CO 80640
Phone: (303) 853-8053
Fax:
www.ForterraBP.com

Contractor: JBS Pipeline Contractors, CO
Project: Trails at Crowfoot F2 (DR HORTON)
Location: CO Parker
Order Nbr: 9419134MH1
Remarks: ASTM C478

Sanitary Sewer
48" (I.D.) Manhole
SA TC-SSMH-44
Date: 07/31/2019
Plant: 155 Henderson Precast
Coordinator: Chris Hoganson

Design Build Height	
Top of Casting	+ 6045.56
Outlet Invert	- 6034.56
Wall Thk/Inv Adj	+ .14
Design Height	= 11.14
Casting/Adj Ring	- 1.13
Manhole Hgt	= 10.02

Stack Build Height	
Casting	+ .71
Adjusting Ring	+ .42
Cone	+ 3.00
Riser	+ 7.00
Base Thickness	+ .00
Outside Height	= 11.13

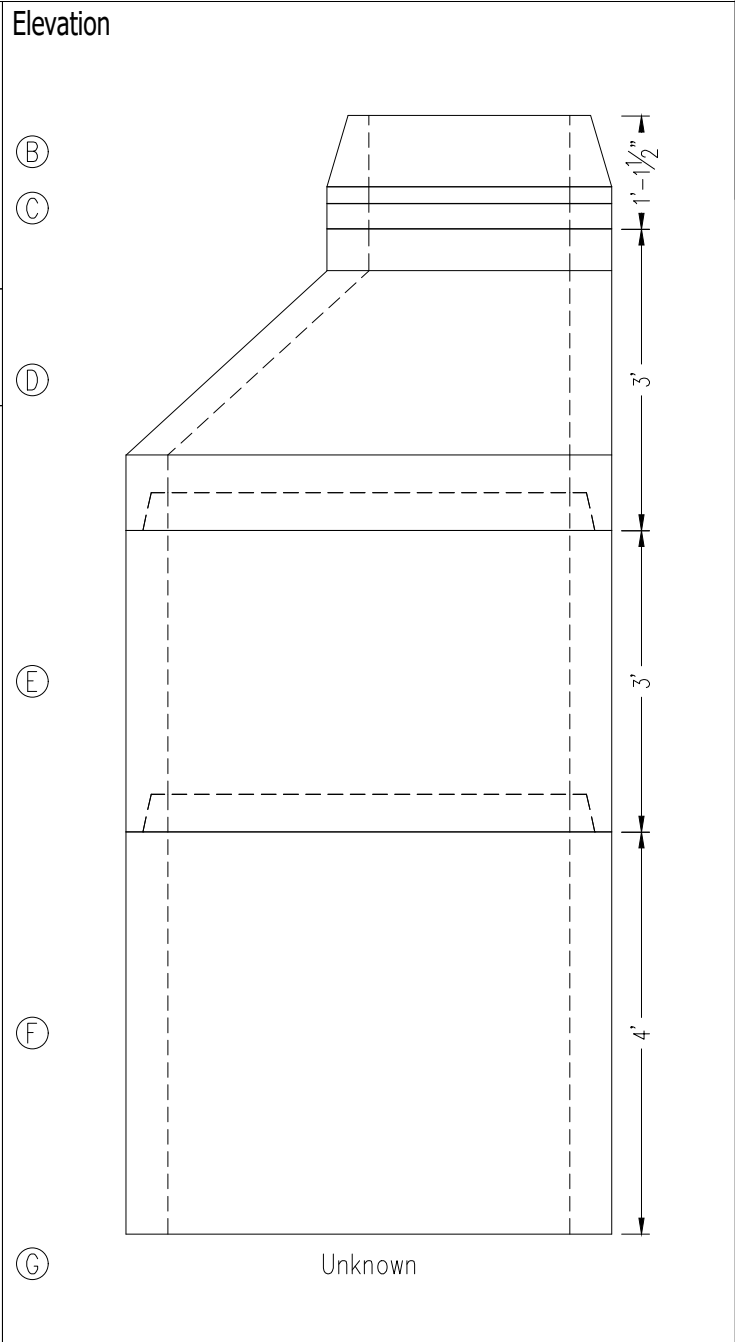

Opening Schedule								(HF=Hole Former, DO=Dig Out)
ID	Pipe Size	Invert	Pipe Up	Opening/ O.D.	Connector	Top of Hole Up	C-Line Hole Up	Btm of Hole Up

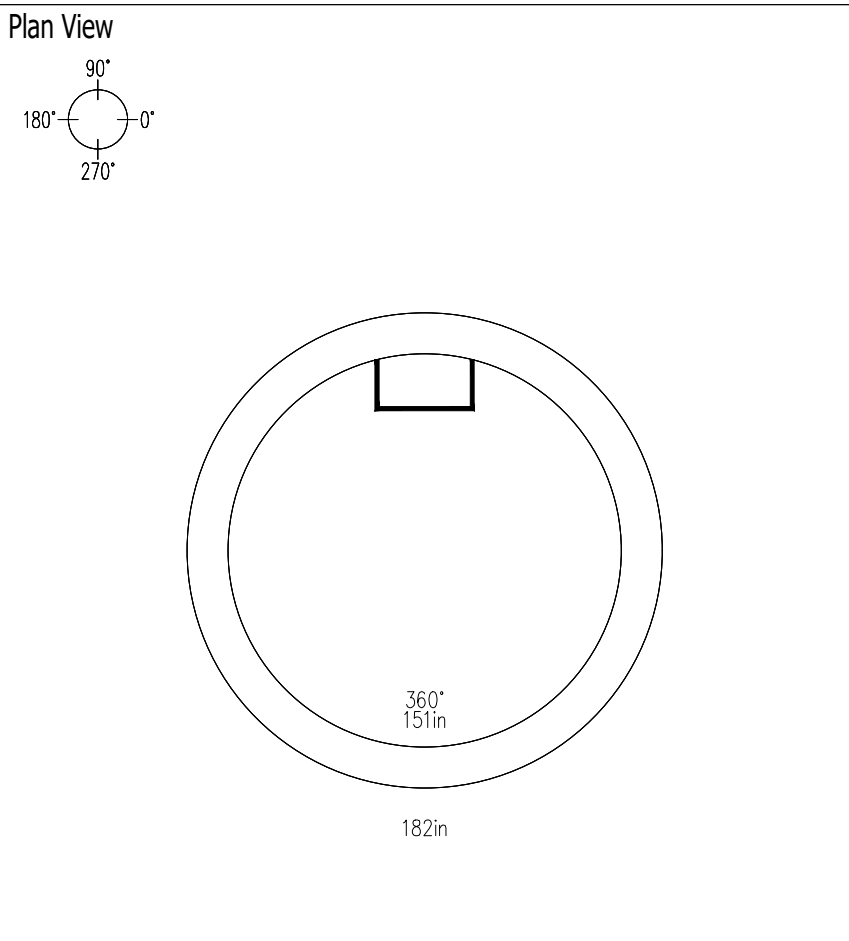

Notes
PIPE INVERT ELEVATION = TOP OF CAST IN PLACE BASE (4" ABOVE TOP OF OD OF HIGHEST PIPE).
VAC TEST REQ'D

Steps: 12" On Center 90°

ID	Description	Product No	Hgt	Qty	Weight
A	EJ 2400A Cover Sewer Knobby	9000100000660	.00	1	148
B	EJ 2420Z2 Ring 8"	9000100000713	.71	1	149
C	24x2 Interlock Adjusting Ring	909010024020A	.17	1	80
C	24x3 Interlock Adjusting Ring	909010024030A	.25	1	120
D	48x3.0 24 Ecc Cone PHS S	204809V2100000030	3.00	1	2,900
E	48x3.0 BBL PHS S	204801V0100000030	3.00	1	2,610
F	48x4.0 BBL FB PHS S	204801V5100000040	4.00	1	3,480
G	Unknown		.00	1	0
Total Weight (lbs)					9,487

Misc. Items	Qty
Description	
Gasket PHS 48 inch SSMH	2
Joint Seal CS102 1X14.5	1

Production Use	
Mfg. Date:	
Ship Date:	
Frame/Ring:	
Grate/Cover:	
PREPOUR:	
POSTPOUR:	

Design Build Height			Stack Build Height		
Top of Casting	+	6055.43	Casting	+	.71
Outlet Invert	-	6044.43	Adjusting Ring	+	.42
Wall Thk/Inv Adj	+	.14	Cone	+	3.00
Design Height	=	11.14	Riser	+	7.00
Casting/Adj Ring	-	1.13	Base Thickness	+	.00
Manhole Hgt	=	10.02	Outside Height	=	11.13

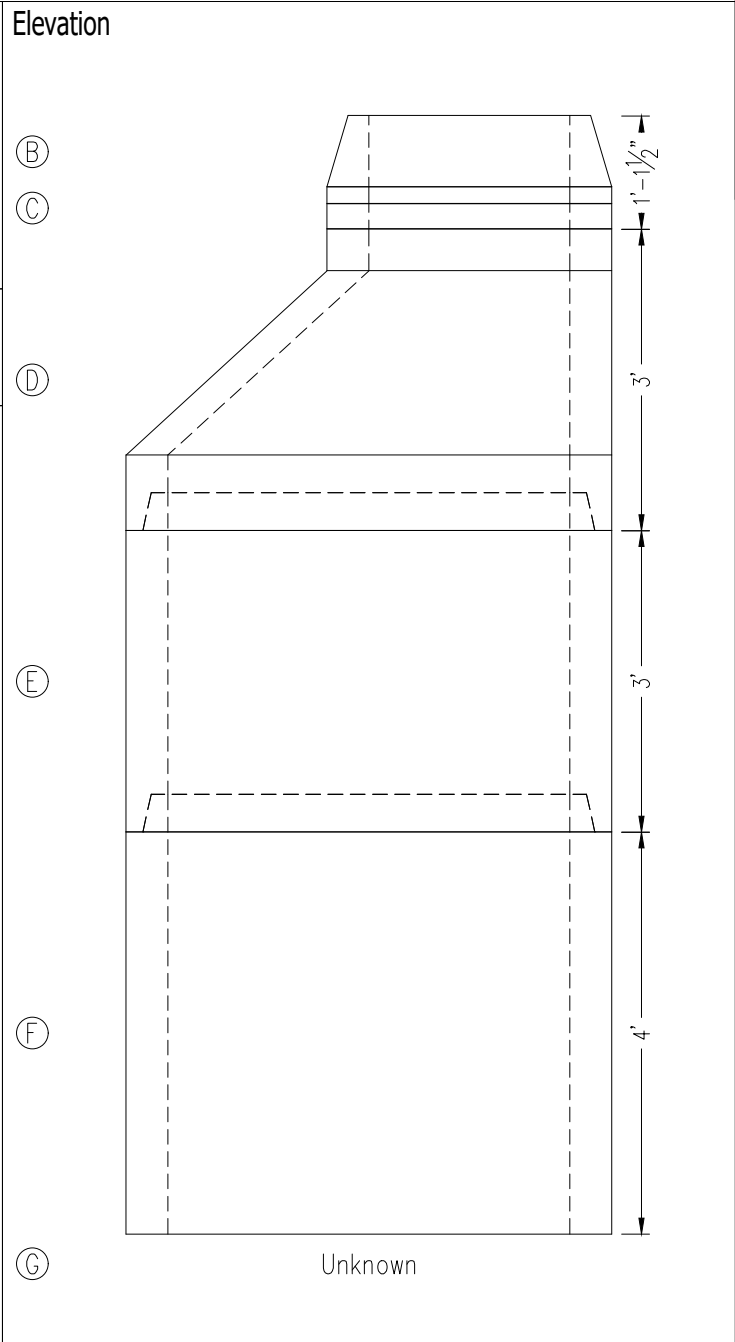

Opening Schedule (HF=Hole Former, DO=Dig Out)

ID	Pipe Size	Invert	Pipe Up	Opening/ O.D.	Connector	Top of Hole Up	C-Line Hole Up	Btm of Hole Up

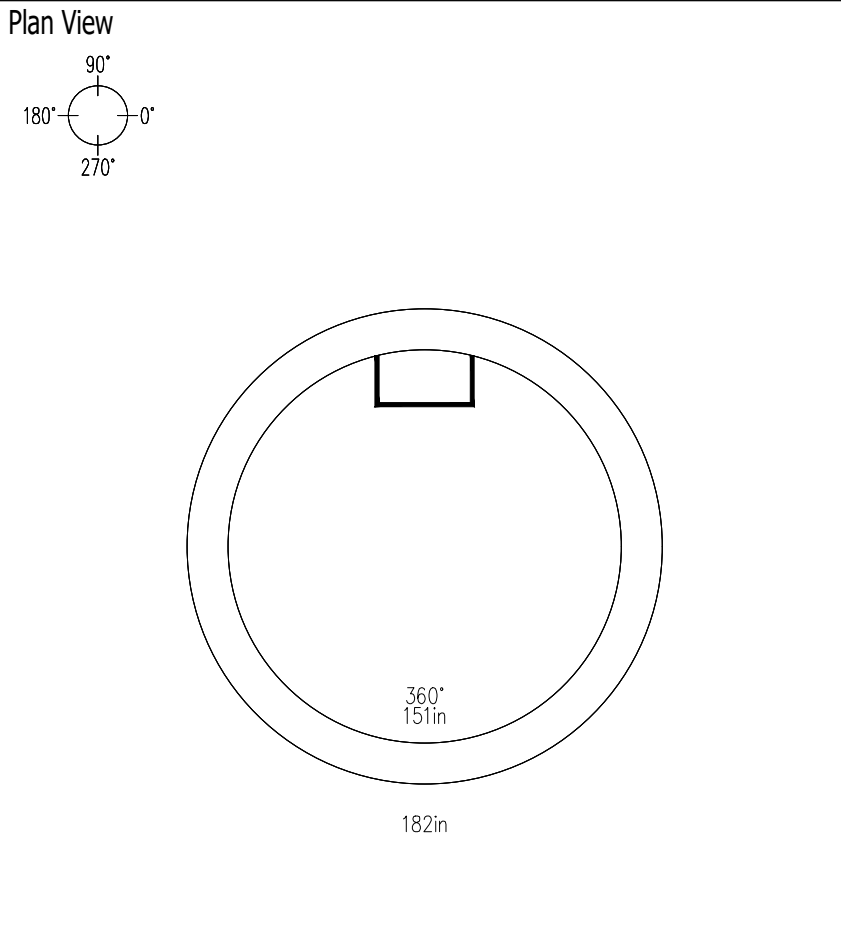

Notes
 PIPE INVERT ELEVATION = TOP OF CAST IN PLACE BASE (4" ABOVE TOP OF OD OF HIGHEST PIPE).
 VAC TEST REQ'D

Steps: 12" On Center 90°

ID	Description	Product No	Hgt	Qty	Weight
A	EJ 2400A Cover Sewer Knobby	9000100000660	.00	1	148
B	EJ 2420Z2 Ring 8"	9000100000713	.71	1	149
C	24x2 Interlock Adjusting Ring	909010024020A	.17	1	80
C	24x3 Interlock Adjusting Ring	909010024030A	.25	1	120
D	48x3.0 24 Ecc Cone PHS S	204809V2100000030	3.00	1	2,900
E	48x3.0 BBL PHS S	204801V0100000030	3.00	1	2,610
F	48x4.0 BBL FB PHS S	204801V5100000040	4.00	1	3,480
G	Unknown		.00	1	0
Total Weight (lbs)					9,487

Misc. Items	Qty	Production Use
Description		Mfg. Date:
Gasket PHS 48 inch SSMH	2	Ship Date:
Joint Seal CS102 1X14.5	1	Frame/Ring:
		Grate/Cover:
		PREPOUR:
		POSTPOUR:



9455 Boston Ct.
 Henderson, CO 80640
 Phone: (303) 853-8053
 Fax:
 www.ForterraBP.com

Contractor: JBS Pipeline Contractors, CO
Project: Trails at Crowfoot F2 (DR HORTON)
Location: CO Parker
Order Nbr: 9419134MH1
Remarks: ASTM C478

Sanitary Sewer
48" (I.D.) Manhole
SA TC-SSMH-45
 Date: 07/31/2019
 Plant: 155 Henderson Precast
 Coordinator: Chris Hoganson

Design Build Height			Stack Build Height		
Top of Casting	+	6067.55	Casting	+	.71
Outlet Invert	-	6056.55	Adjusting Ring	+	.42
Wall Thk/Inv Adj	+	.14	Cone	+	3.00
Design Height	=	11.14	Riser	+	7.00
Casting/Adj Ring	-	1.13	Base Thickness	+	.00
Manhole Hgt	=	10.02	Outside Height	=	11.13

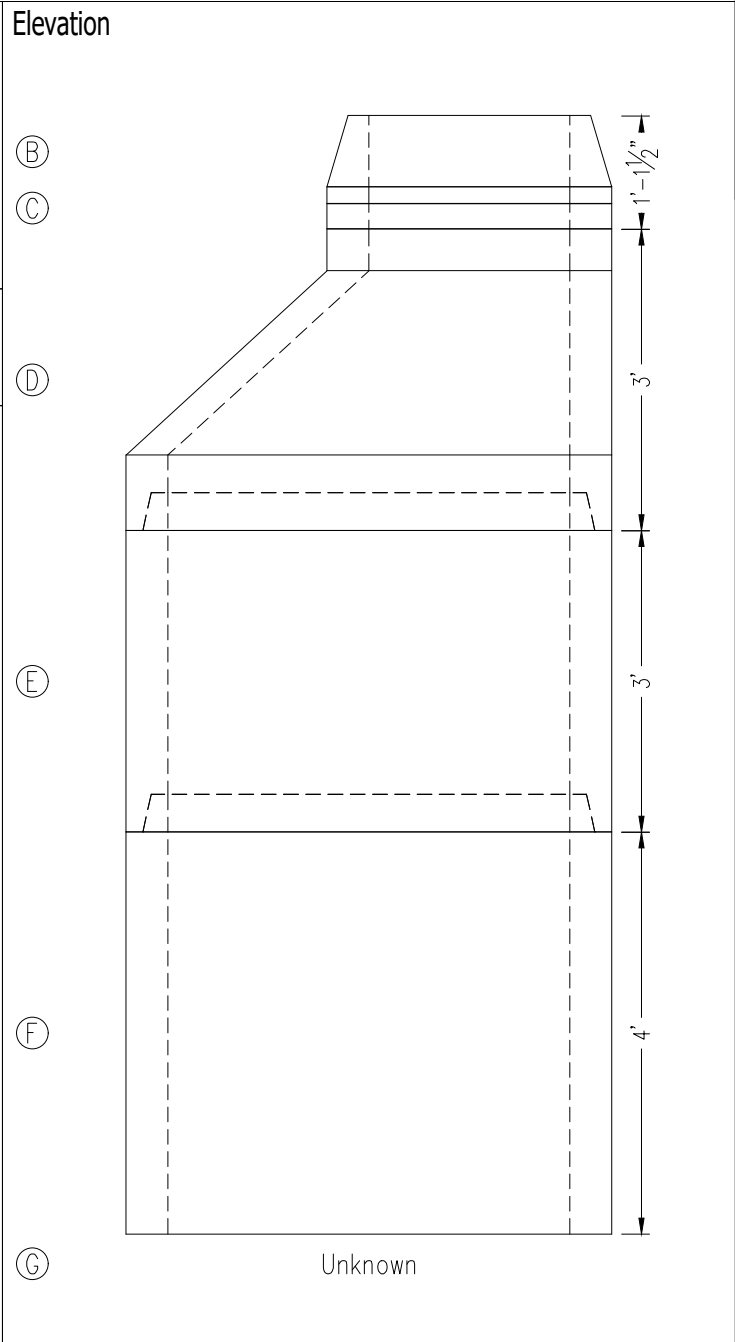

Opening Schedule (HF=Hole Former, DO=Dig Out)

ID	Pipe Size	Invert	Pipe Up	Opening/ O.D.	Connector	Top of Hole Up	C-Line Hole Up	Btm of Hole Up

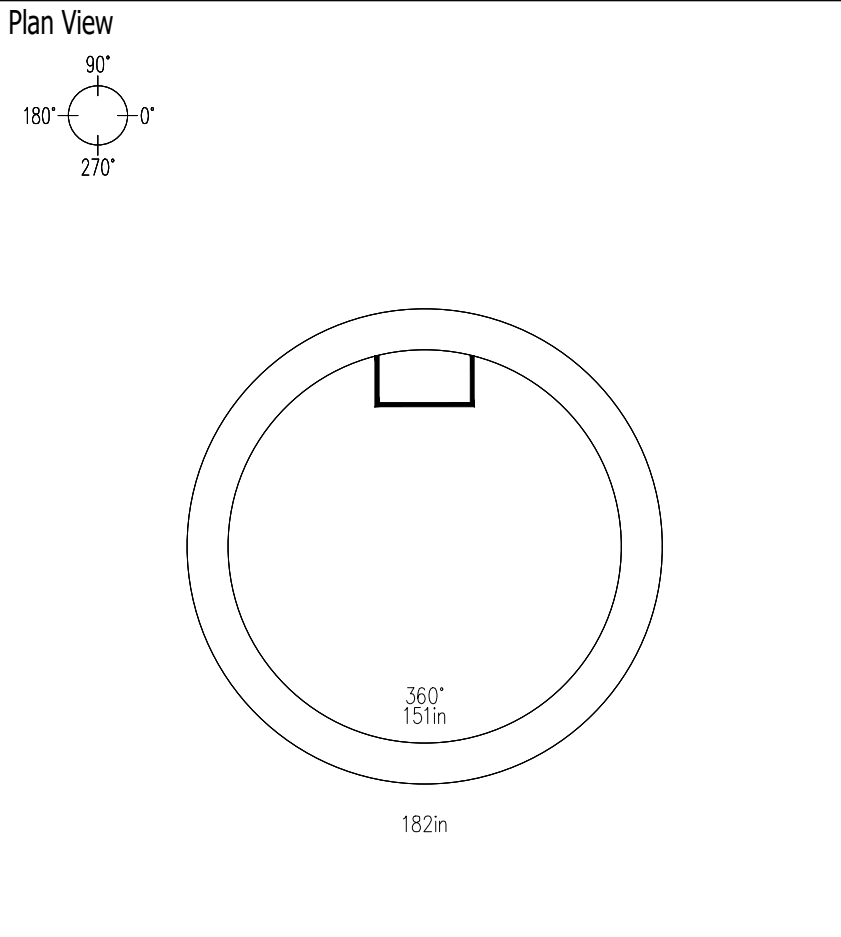

Notes
 PIPE INVERT ELEVATION = TOP OF CAST IN PLACE BASE (4" ABOVE TOP OF OD OF HIGHEST PIPE).
 VAC TEST REQ'D

Steps: 12" On Center 90°

ID	Description	Product No	Hgt	Qty	Weight
A	EJ 2400A Cover Sewer Knobby	9000100000660	.00	1	148
B	EJ 2420Z2 Ring 8"	9000100000713	.71	1	149
C	24x2 Interlock Adjusting Ring	909010024020A	.17	1	80
C	24x3 Interlock Adjusting Ring	909010024030A	.25	1	120
D	48x3.0 24 Ecc Cone PHS S	204809V2100000030	3.00	1	2,900
E	48x3.0 BBL PHS S	204801V0100000030	3.00	1	2,610
F	48x4.0 BBL FB PHS S	204801V5100000040	4.00	1	3,480
G	Unknown		.00	1	0
Total Weight (lbs)					9,487

Misc. Items	
Description	Qty
Gasket PHS 48 inch SSMH	2
Joint Seal CS102 1X14.5	1

Production Use	
Mfg. Date:	
Ship Date:	
Frame/Ring:	
Grate/Cover:	
PREPOUR:	
POSTPOUR:	



9455 Boston Ct.
Henderson, CO 80640
Phone: (303) 853-8053
Fax:
www.ForterraBP.com

Contractor: JBS Pipeline Contractors, CO
Project: Trails at Crowfoot F2 (DR HORTON)
Location: CO Parker
Order Nbr: 9419134MH1
Remarks: ASTM C478

Sanitary Sewer
48" (I.D.) Manhole
SA TC-SSMH-30
Date: 07/31/2019
Plant: 155 Henderson Precast
Coordinator: Chris Hoganson

Design Build Height			Stack Build Height		
Top of Casting	+	6072.50	Casting	+	.71
Outlet Invert	-	6061.50	Adjusting Ring	+	.42
Wall Thk/Inv Adj	+	.14	Cone	+	3.00
Design Height	=	11.14	Riser	+	7.00
Casting/Adj Ring	-	1.13	Base Thickness	+	.00
Manhole Hgt	=	10.02	Outside Height	=	11.13

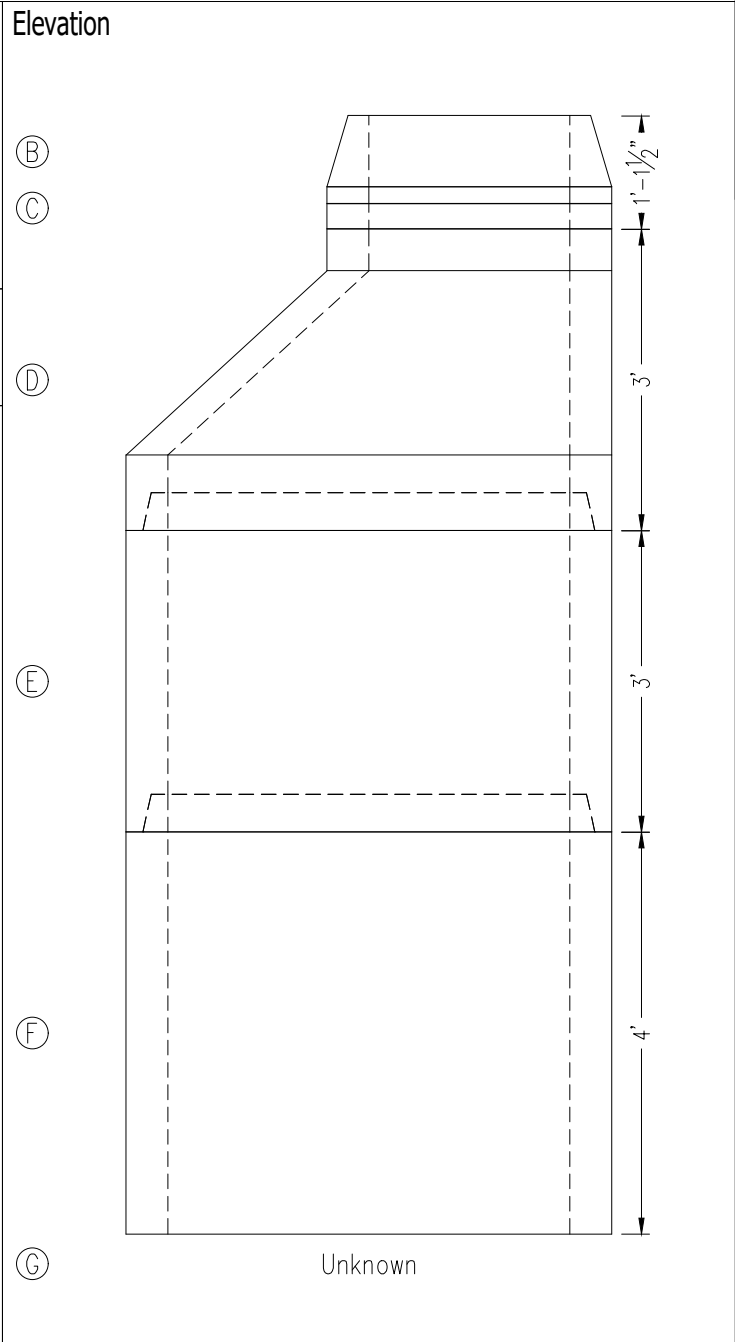

Opening Schedule (HF=Hole Former, DO=Dig Out)

ID	Pipe Size	Invert	Pipe Up	Opening/ O.D.	Connector	Top of Hole Up	C-Line Hole Up	Btm of Hole Up

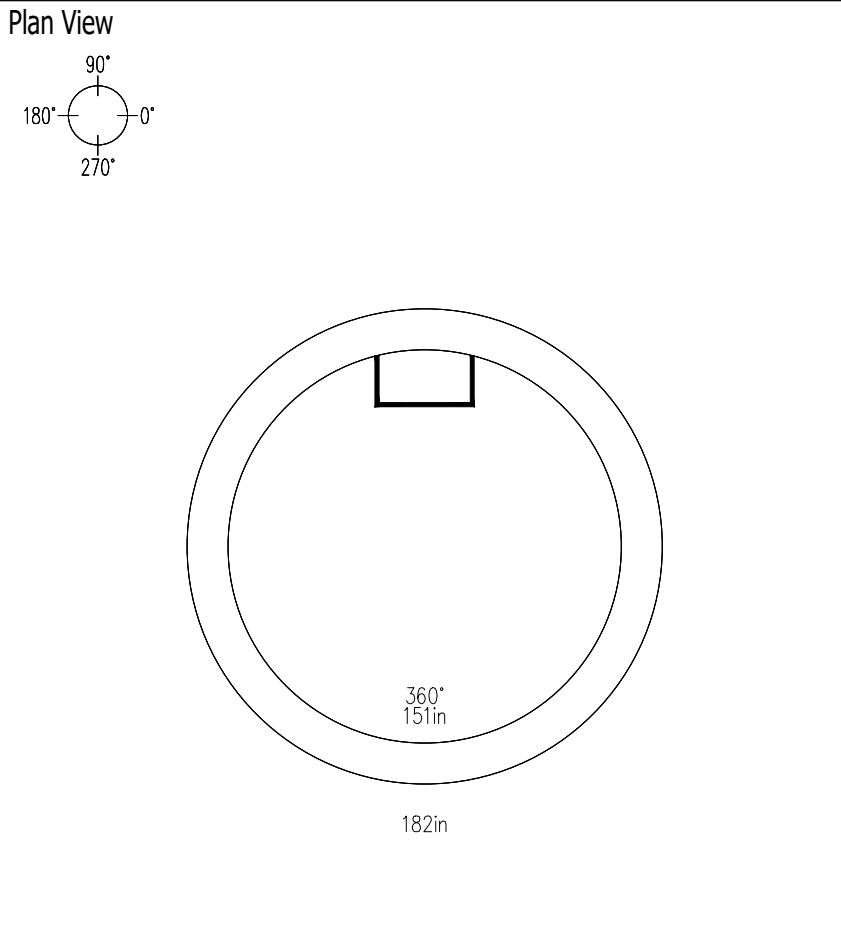

Notes
PIPE INVERT ELEVATION = TOP OF CAST IN PLACE BASE (4" ABOVE TOP OF OD OF HIGHEST PIPE).
VAC TEST REQ'D

Steps: 12" On Center 90°

ID	Description	Product No	Hgt	Qty	Weight
A	EJ 2400A Cover Sewer Knobby	9000100000660	.00	1	148
B	EJ 2420Z2 Ring 8"	9000100000713	.71	1	149
C	24x2 Interlock Adjusting Ring	909010024020A	.17	1	80
C	24x3 Interlock Adjusting Ring	909010024030A	.25	1	120
D	48x3.0 24 Ecc Cone PHS S	204809V2100000030	3.00	1	2,900
E	48x3.0 BBL PHS S	204801V0100000030	3.00	1	2,610
F	48x4.0 BBL FB PHS S	204801V5100000040	4.00	1	3,480
G	Unknown		.00	1	0
Total Weight (lbs)					9,487

Misc. Items	
Description	Qty
Gasket PHS 48 inch SSMH	2
Joint Seal CS102 1X14.5	1

Production Use	
Mfg. Date:	
Ship Date:	
Frame/Ring:	
Grate/Cover:	
PREPOUR:	
POSTPOUR:	



9455 Boston Ct.
 Henderson, CO 80640
 Phone: (303) 853-8053
 Fax:
 www.ForterraBP.com

Contractor: JBS Pipeline Contractors, CO
Project: Trails at Crowfoot F2 (DR HORTON)
Location: CO Parker
Order Nbr: 9419134MH1
Remarks: ASTM C478

Sanitary Sewer
48" (I.D.) Manhole
SA TC-SSMH-31

Date: 07/31/2019
 Plant: 155 Henderson Precast
 Coordinator: Chris Hoganson

Design Build Height		
Top of Casting	+	6076.42
Outlet Invert	-	6065.50
Wall Thk/Inv Adj	+	.14
Design Height	=	11.06
Casting/Adj Ring	-	1.04
Manhole Hgt	=	10.02

Stack Build Height		
Casting	+	.71
Adjusting Ring	+	.33
Cone	+	3.00
Riser	+	7.00
Base Thickness	+	.00
Outside Height	=	11.04

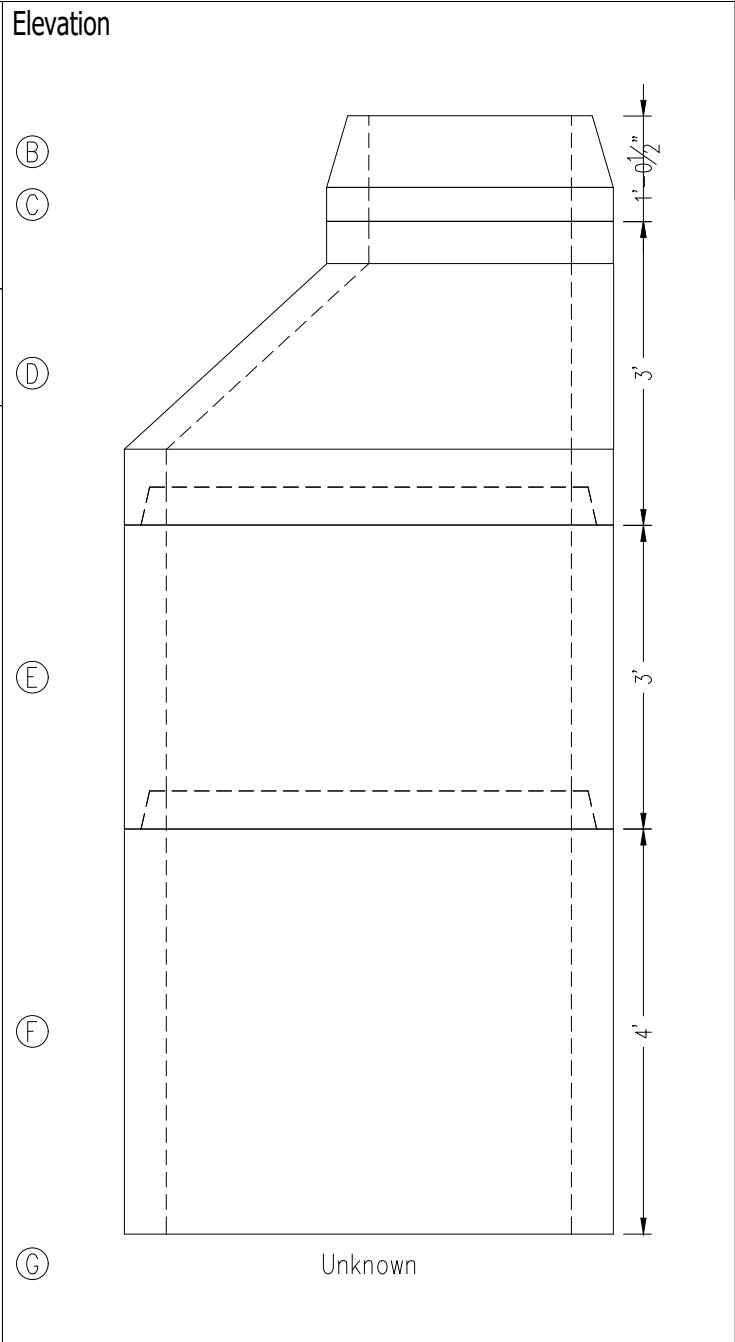

Opening Schedule								(HF=Hole Former, DO=Dig Out)			
ID	Pipe Size	Invert	Invert Up	Pipe O.D.	Opening/Connector	Top of Hole Up	C-Line Hole Up	Btm of Hole Up			

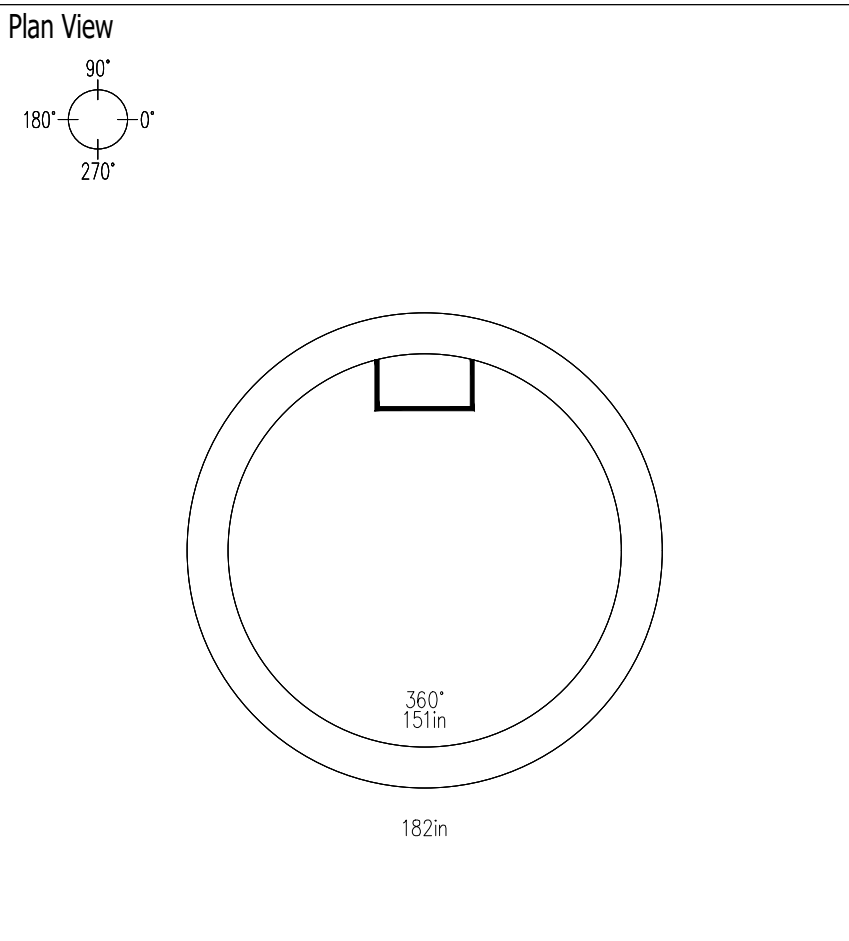

Notes
 PIPE INVERT ELEVATION = TOP OF CAST IN PLACE BASE (4" ABOVE TOP OF OD OF HIGHEST PIPE).
 VAC TEST REQ'D

Steps: 12" On Center 90°

Item List					
ID	Description	Product No	Hgt	Qty	Weight
A	EJ 2400A Cover Sewer Knobby	9000100000660	.00	1	148
B	EJ 2420Z2 Ring 8"	9000100000713	.71	1	149
C	24x4 Interlock Adjusting Ring	909010024040A	.33	1	160
D	48x3.0 24 Ecc Cone PHS S	204809V2100000030	3.00	1	2,900
E	48x3.0 BBL PHS S	204801V0100000030	3.00	1	2,610
F	48x4.0 BBL FB PHS S	204801V5100000040	4.00	1	3,480
G	Unknown		.00	1	0
Total Weight (lbs)					9,447

Misc. Items	
Description	Qty
Gasket PHS 48 inch SSMH	2
Joint Seal CS102 1X14.5	1

Production Use	
Mfg. Date:	
Ship Date:	
Frame/Ring:	
Grate/Cover:	
PREPOUR:	
POSTPOUR:	



9455 Boston Ct.
 Henderson, CO 80640
 Phone: (303) 853-8053
 Fax:
 www.ForterraBP.com

Contractor: JBS Pipeline Contractors, CO
Project: Trails at Crowfoot F2 (DR HORTON)
Location: CO Parker
Order Nbr: 9419134MH1
Remarks: ASTM C478

Sanitary Sewer
48" (I.D.) Manhole
SA TC-SSMH-32
 Date: 07/31/2019
 Plant: 155 Henderson Precast
 Coordinator: Chris Hoganson

Design Build Height			Stack Build Height		
Top of Casting	+	6048.79	Casting	+	.71
Outlet Invert	-	6037.90	Adjusting Ring	+	.33
Wall Thk/Inv Adj	+	.14	Cone	+	3.00
Design Height	=	11.03	Riser	+	7.00
Casting/Adj Ring	-	1.04	Base Thickness	+	.00
Manhole Hgt	=	9.99	Outside Height	=	11.04

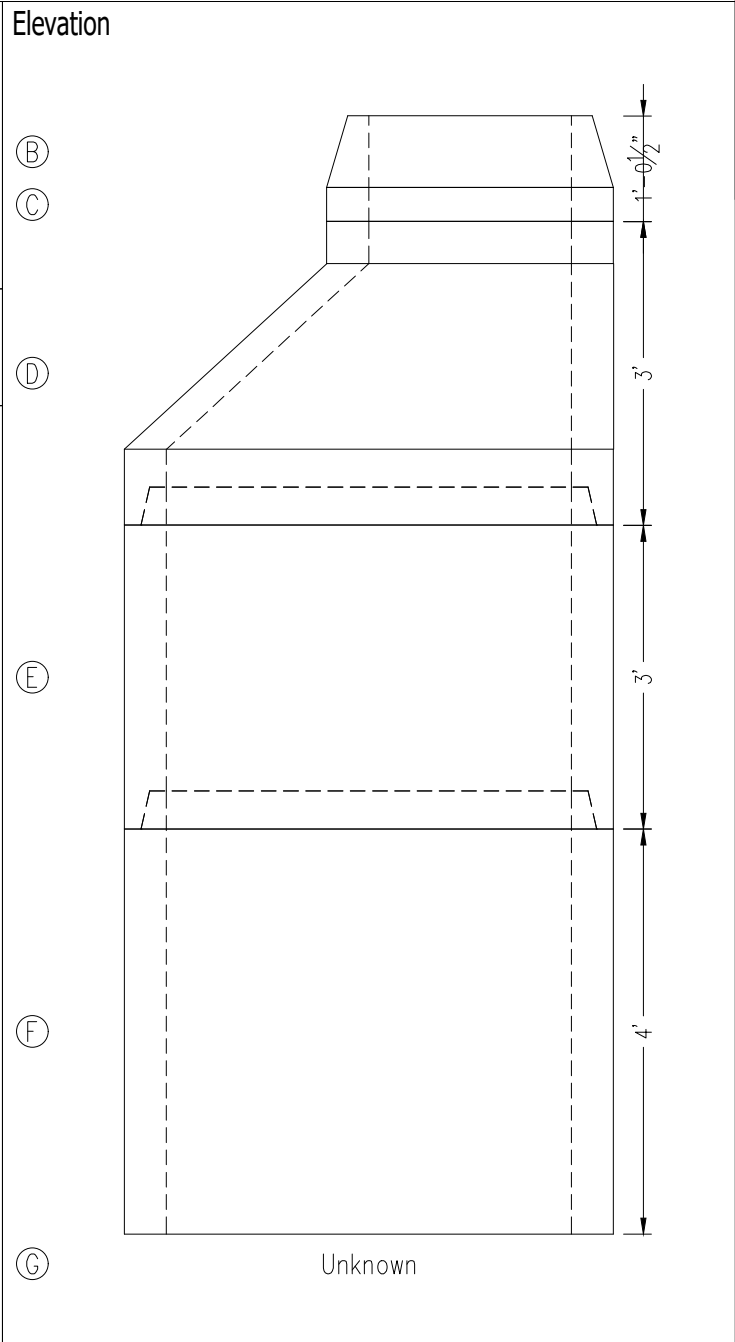

Opening Schedule (HF=Hole Former, DO=Dig Out)

ID	Pipe Size	Invert	Pipe Up	Opening/ O.D.	Connector	Top of Hole Up	C-Line Hole Up	Btm of Hole Up

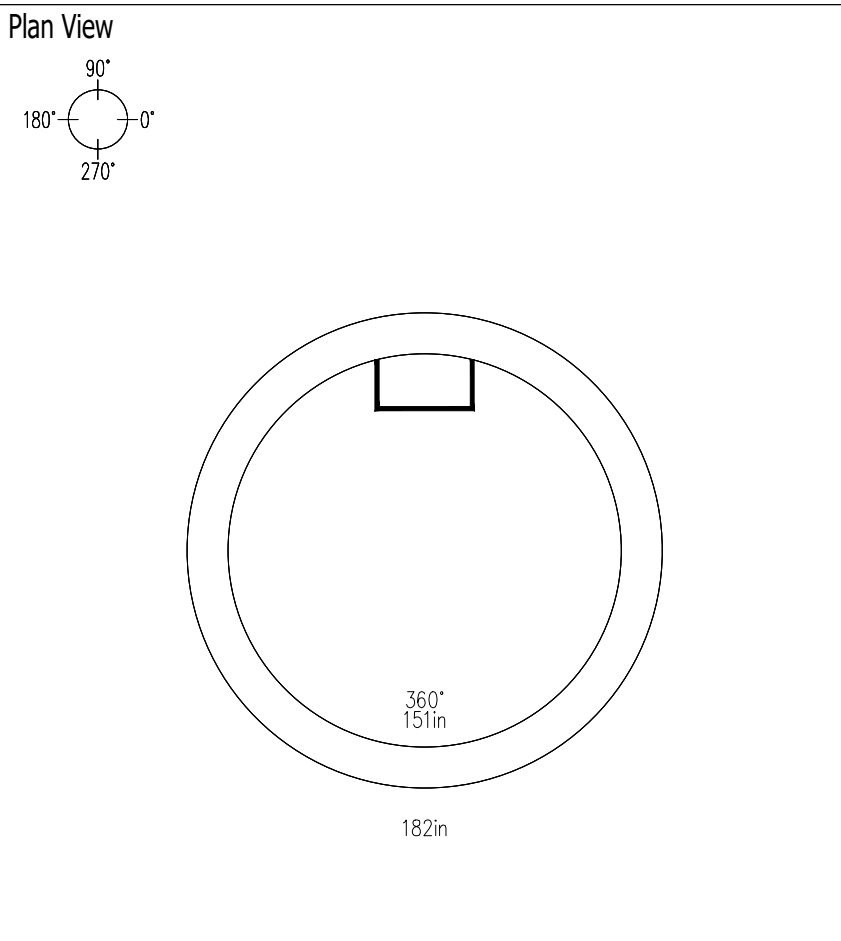

Notes
 PIPE INVERT ELEVATION = TOP OF CAST IN PLACE BASE (4" ABOVE TOP OF OD OF HIGHEST PIPE).
 VAC TEST REQ'D

Steps: 12" On Center 90°

ID	Description	Product No	Hgt	Qty	Weight
A	EJ 2400A Cover Sewer Knobby	9000100000660	.00	1	148
B	EJ 2420Z2 Ring 8"	9000100000713	.71	1	149
C	24x4 Interlock Adjusting Ring	909010024040A	.33	1	160
D	48x3.0 24 Ecc Cone PHS S	204809V2100000030	3.00	1	2,900
E	48x3.0 BBL PHS S	204801V0100000030	3.00	1	2,610
F	48x4.0 BBL FB PHS S	204801V5100000040	4.00	1	3,480
G	Unknown		.00	1	0
Total Weight (lbs)					9,447

Misc. Items	
Description	Qty
Gasket PHS 48 inch SSMH	2
Joint Seal CS102 1X14.5	1

Production Use	
Mfg. Date:	
Ship Date:	
Frame/Ring:	
Grate/Cover:	
PREPOUR:	
POSTPOUR:	



9455 Boston Ct.
 Henderson, CO 80640
 Phone: (303) 853-8053
 Fax:
 www.ForterraBP.com

Contractor: JBS Pipeline Contractors, CO
Project: Trails at Crowfoot F2 (DR HORTON)
Location: CO Parker
Order Nbr: 9419134MH1
Remarks: ASTM C478

Sanitary Sewer
48" (I.D.) Manhole
SA TC-SSMH-46
 Date: 07/31/2019
 Plant: 155 Henderson Precast
 Coordinator: Chris Hoganson

Design Build Height		
Top of Casting	+	6052.59
Outlet Invert	-	6041.68
Wall Thk/Inv Adj	+	.14
Design Height	=	11.05
Casting/Adj Ring	-	1.04
Manhole Hgt	=	10.01

Stack Build Height		
Casting	+	.71
Adjusting Ring	+	.33
Cone	+	2.00
Riser	+	8.00
Base Thickness	+	.00
Outside Height	=	11.04

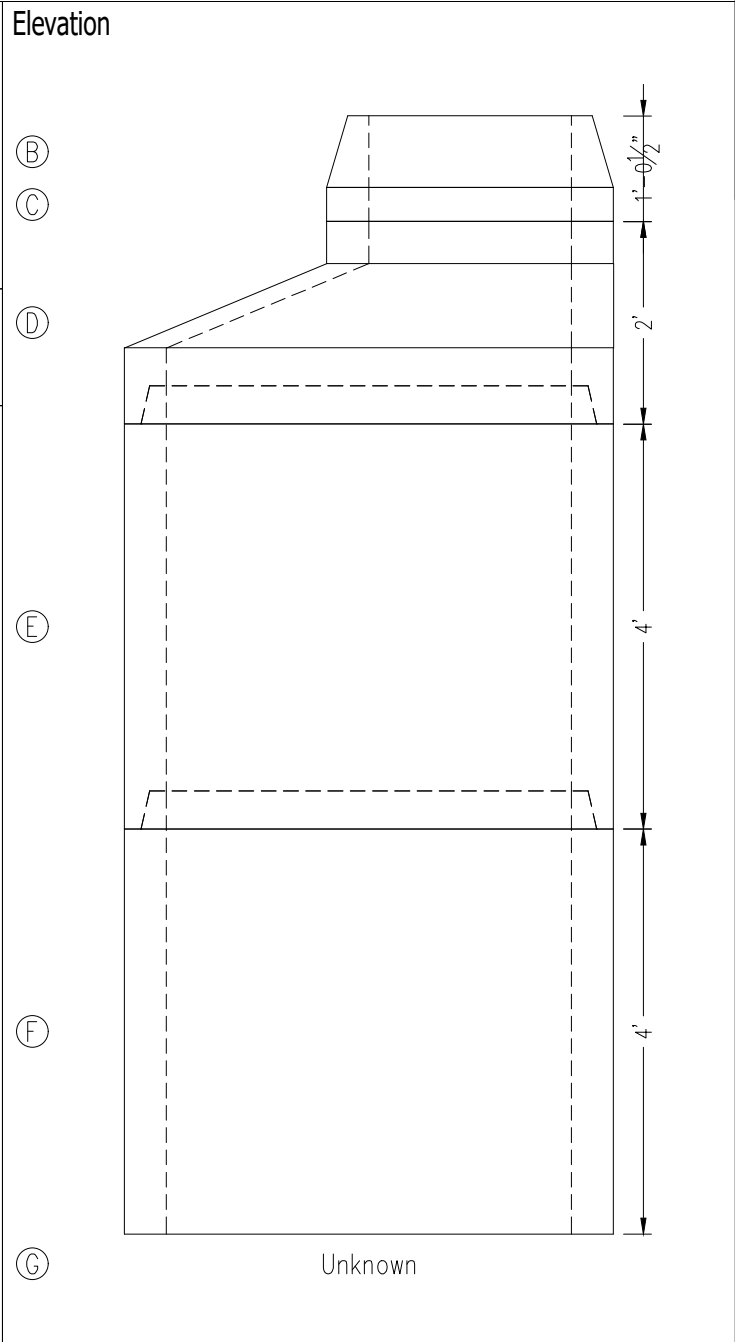

Opening Schedule								(HF=Hole Former, DO=Dig Out)			
ID	Pipe Size	Invert	Invert Up	Pipe O.D.	Opening/ Connector	Top of Hole Up	C-Line Hole Up	Btm of Hole Up			

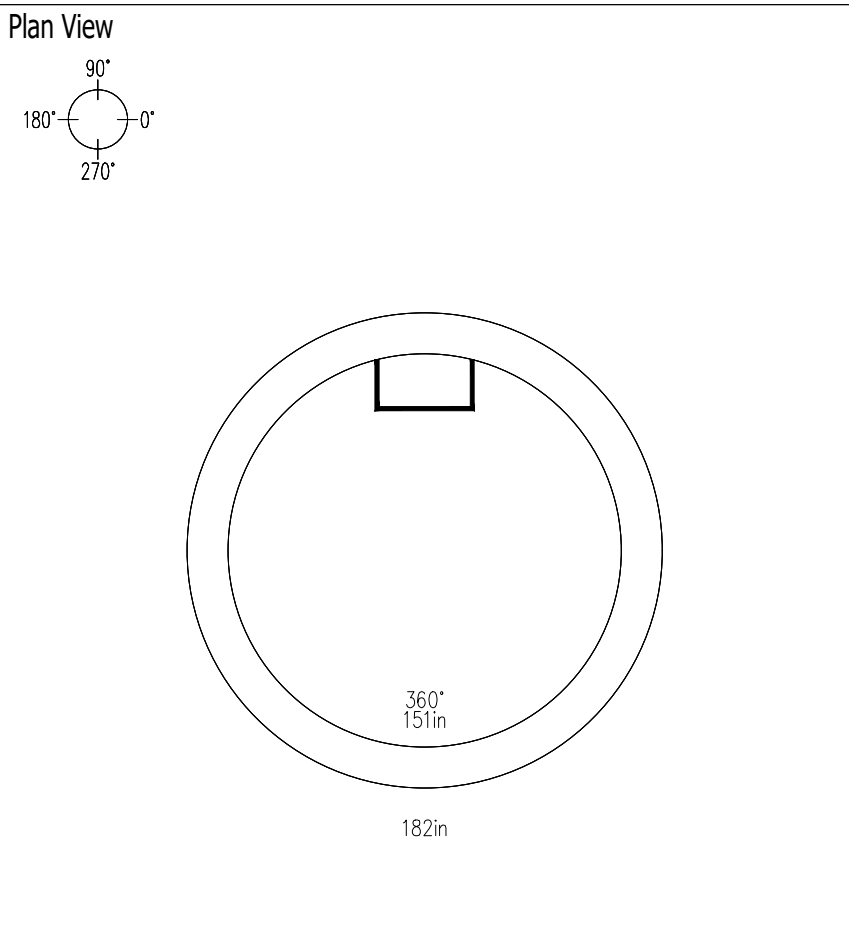

Steps: 12" On Center 90°

Notes
 PIPE INVERT ELEVATION = TOP OF CAST IN PLACE BASE (4" ABOVE TOP OF OD OF HIGHEST PIPE).
 VAC TEST REQ'D

Item List					
ID	Description	Product No	Hgt	Qty	Weight
A	EJ 2400A Cover Sewer Knobby	9000100000660	.00	1	148
B	EJ 2420Z2 Ring 8"	9000100000713	.71	1	149
C	24x4 Interlock Adjusting Ring	909010024040A	.33	1	160
D	48x2.0 24 Ecc Cone PHS S	204809V2100000020	2.00	1	1,650
E	48x4.0 BBL PHS S	204801V0100000040	4.00	1	3,480
F	48x4.0 BBL FB PHS S	204801V5100000040	4.00	1	3,480
G	Unknown		.00	1	0
Total Weight (lbs)					9,067

Misc. Items		Production Use	
Description	Qty	Mfg. Date:	
Gasket PHS 48 inch SSMH	2	Ship Date:	
Joint Seal CS102 1X14.5	1	Frame/Ring:	
		Grate/Cover:	
		PREPOUR:	
		POSTPOUR:	

Design Build Height			Stack Build Height		
Top of Casting	+	6055.86	Casting	+	.71
Outlet Invert	-	6044.93	Adjusting Ring	+	.33
Wall Thk/Inv Adj	+	.14	Cone	+	2.00
Design Height	=	11.07	Riser	+	8.00
Casting/Adj Ring	-	1.04	Base Thickness	+	.00
Manhole Hgt	=	10.03	Outside Height	=	11.04

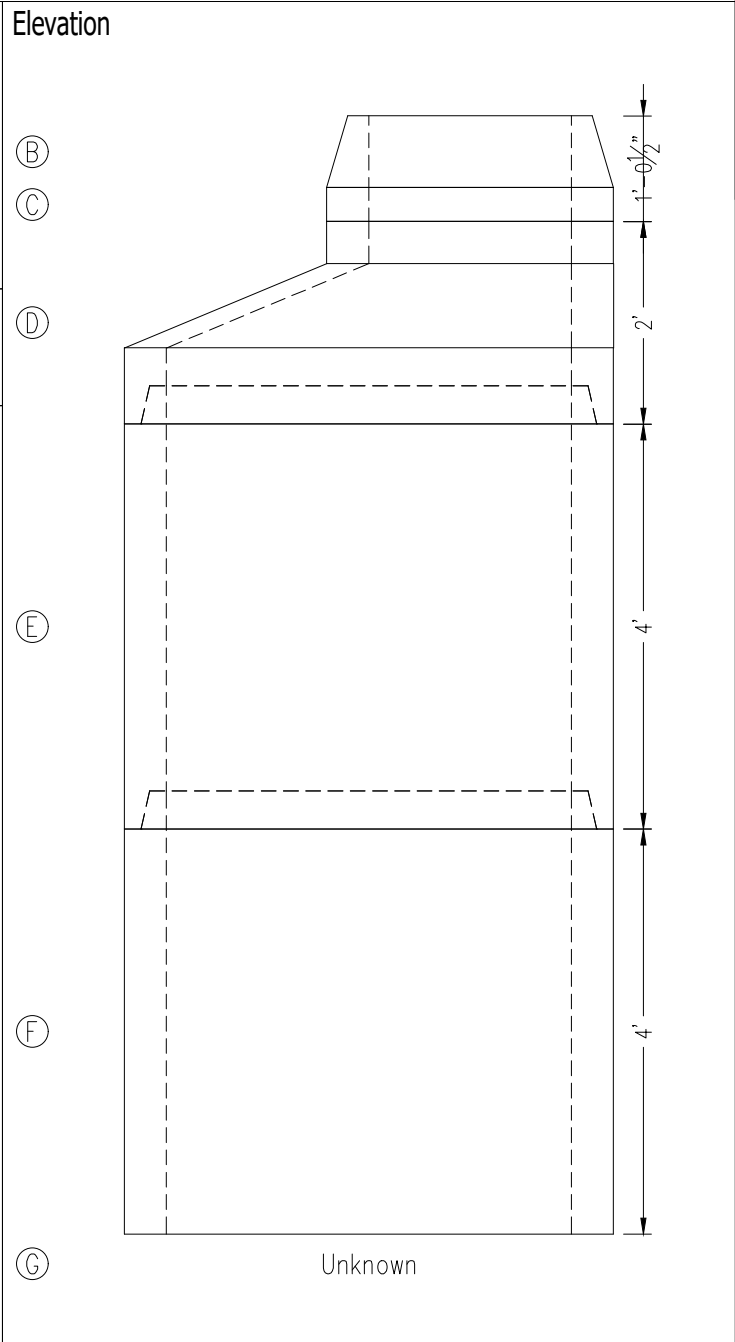

Opening Schedule (HF=Hole Former, DO=Dig Out)

ID	Pipe Size	Invert	Invert Up	Pipe O.D.	Opening/Connector	Top of Hole Up	C-Line Hole Up	Btm of Hole Up

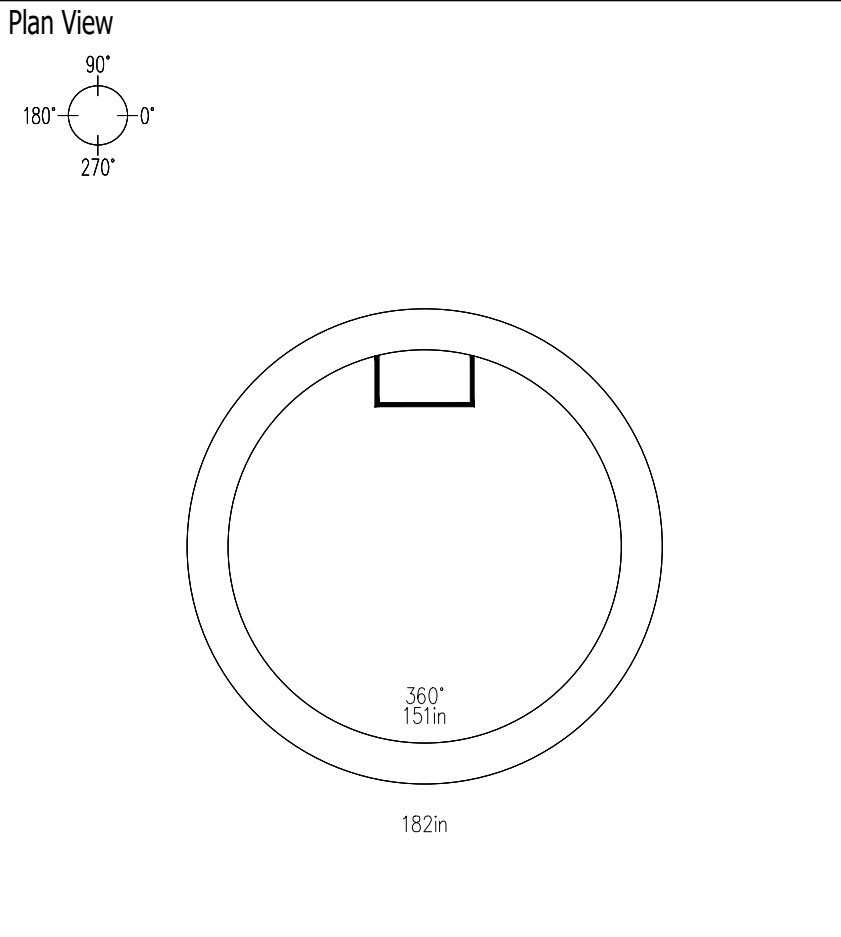

Notes
PIPE INVERT ELEVATION = TOP OF CAST IN PLACE BASE (4" ABOVE TOP OF OD OF HIGHEST PIPE).
VAC TEST REQ'D

Steps: 12" On Center 90°

ID	Description	Product No	Hgt	Qty	Weight
A	EJ 2400A Cover Sewer Knobby	9000100000660	.00	1	148
B	EJ 2420Z2 Ring 8"	9000100000713	.71	1	149
C	24x4 Interlock Adjusting Ring	909010024040A	.33	1	160
D	48x2.0 24 Ecc Cone PHS S	204809V2100000020	2.00	1	1,650
E	48x4.0 BBL PHS S	204801V0100000040	4.00	1	3,480
F	48x4.0 BBL FB PHS S	204801V5100000040	4.00	1	3,480
G	Unknown		.00	1	0
Total Weight (lbs)					9,067

Misc. Items	
Description	Qty
Gasket PHS 48 inch SSMH	2
Joint Seal CS102 1X14.5	1

Production Use	
Mfg. Date:	
Ship Date:	
Frame/Ring:	
Grate/Cover:	
PREPOUR:	
POSTPOUR:	

Design Build Height		
Top of Casting	+	6059.39
Outlet Invert	-	6048.44
Wall Thk/Inv Adj	+	.14
Design Height	=	11.09
Casting/Adj Ring	-	1.04
Manhole Hgt	=	10.05

Stack Build Height		
Casting	+	.71
Adjusting Ring	+	.33
Cone	+	2.00
Riser	+	8.00
Base Thickness	+	.00
Outside Height	=	11.04

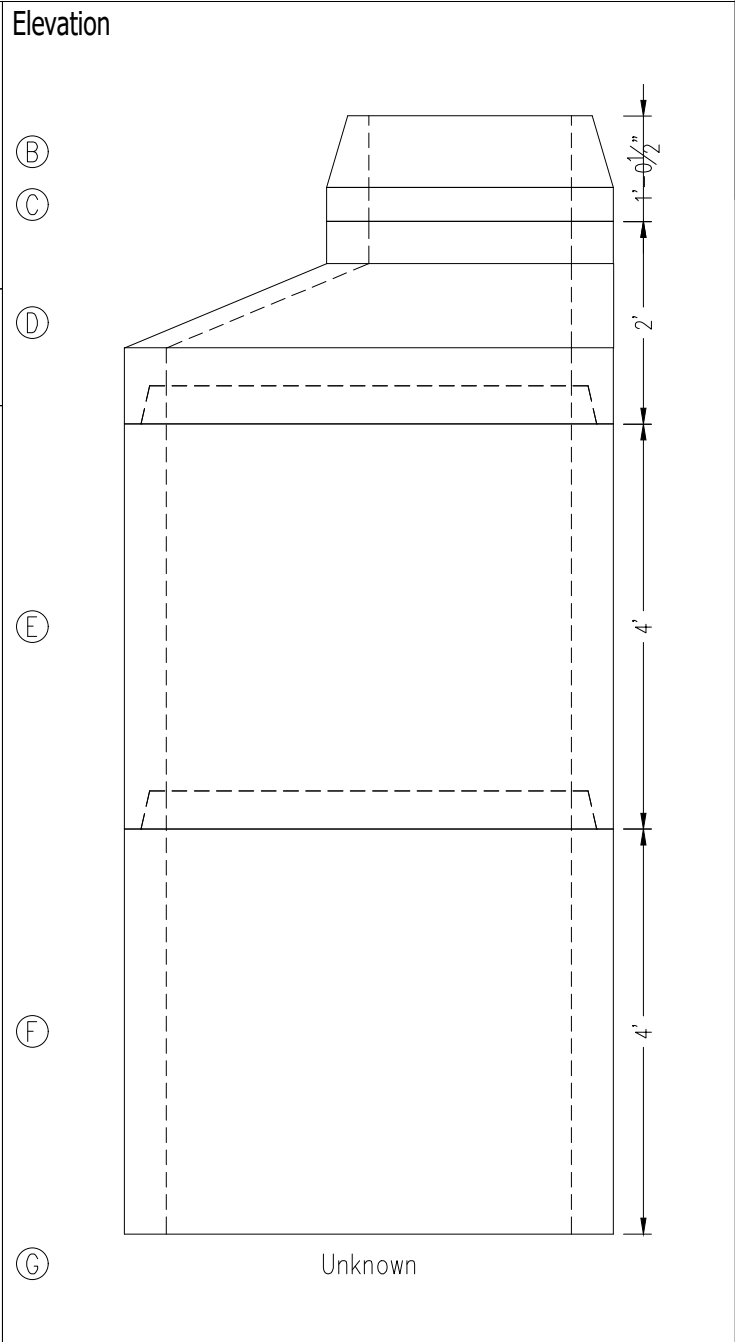

Opening Schedule								(HF=Hole Former, DO=Dig Out)			
ID	Pipe Size	Invert	Invert Up	Pipe O.D.	Opening/Connector	Top of Hole Up	C-Line Hole Up	Btm of Hole Up			

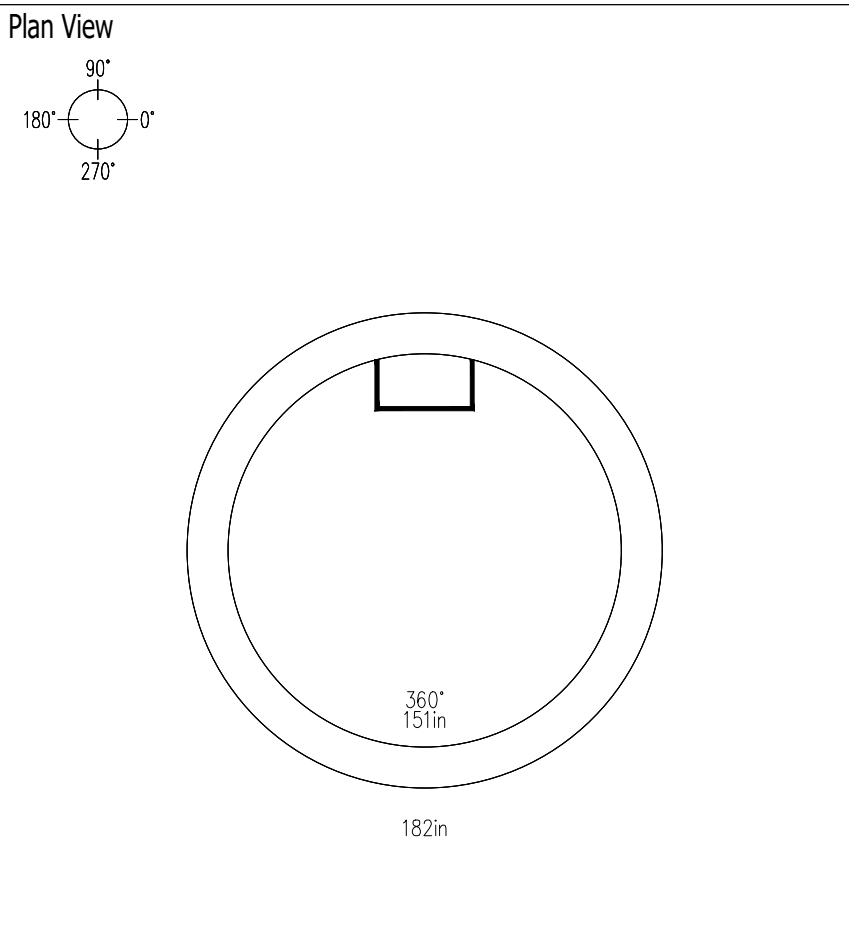

Notes
PIPE INVERT ELEVATION = TOP OF CAST IN PLACE BASE (4" ABOVE TOP OF OD OF HIGHEST PIPE).
VAC TEST REQ'D

Steps: 12" On Center 90°

Item List					
ID	Description	Product No	Hgt	Qty	Weight
A	EJ 2400A Cover Sewer Knobby	9000100000660	.00	1	148
B	EJ 2420Z2 Ring 8"	9000100000713	.71	1	149
C	24x4 Interlock Adjusting Ring	909010024040A	.33	1	160
D	48x2.0 24 Ecc Cone PHS S	204809V2100000020	2.00	1	1,650
E	48x4.0 BBL PHS S	204801V0100000040	4.00	1	3,480
F	48x4.0 BBL FB PHS S	204801V5100000040	4.00	1	3,480
G	Unknown		.00	1	0
Total Weight (lbs)					9,067

Misc. Items	
Description	Qty
Gasket PHS 48 inch SSMH	2
Joint Seal CS102 1X14.5	1

Production Use	
Mfg. Date:	
Ship Date:	
Frame/Ring:	
Grate/Cover:	
PREPOUR:	
POSTPOUR:	

Design Build Height			Stack Build Height		
Top of Casting	+	6076.68	Casting	+	.71
Outlet Invert	-	6065.22	Adjusting Ring	+	.33
Wall Thk/Inv Adj	+	.14	Cone	+	2.50
Design Height	=	11.60	Riser	+	8.00
Casting/Adj Ring	-	1.04	Base Thickness	+	.00
Manhole Hgt	=	10.56	Outside Height	=	11.54

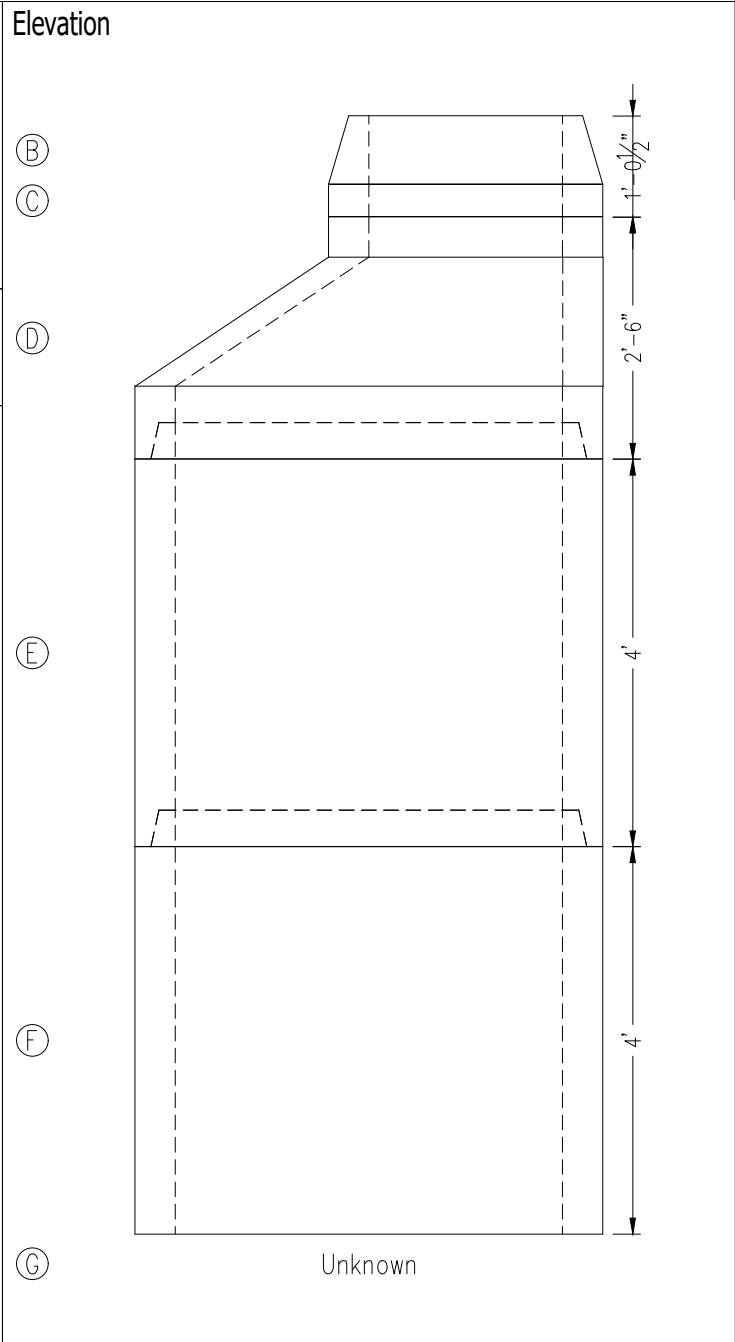

Opening Schedule (HF=Hole Former, DO=Dig Out)

ID	Pipe Size	Invert	Pipe Up	Opening/ O.D.	Connector	Top of Hole Up	C-Line Hole Up	Btm of Hole Up

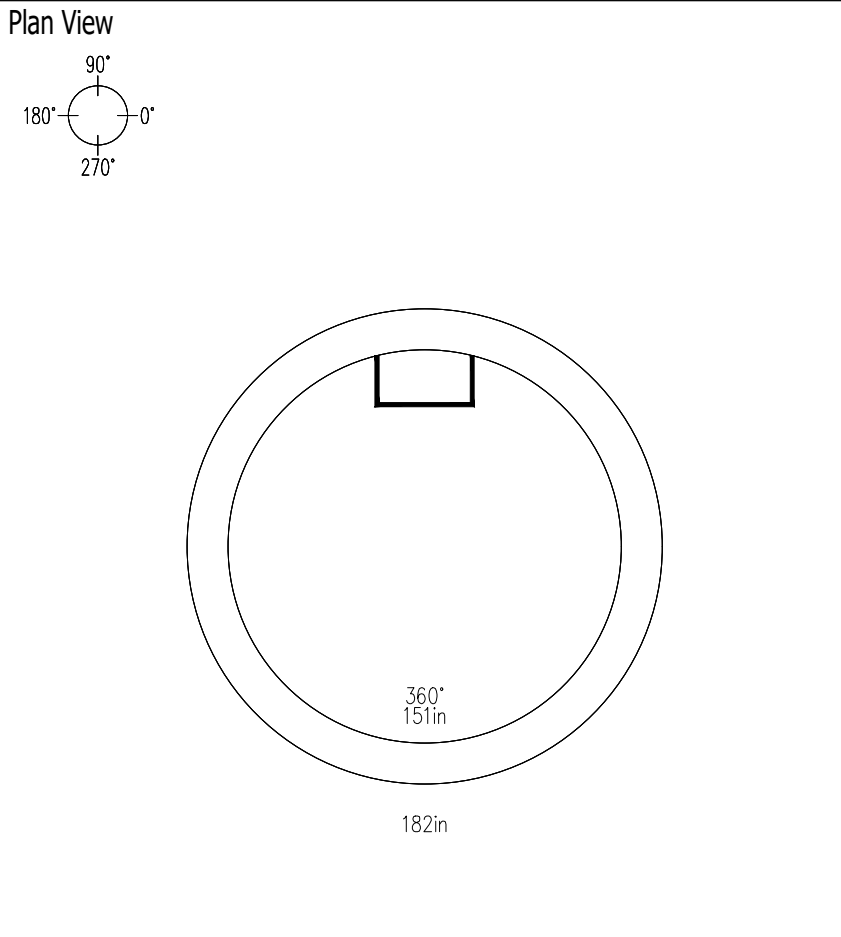

Steps: 12" On Center 90°

Notes
PIPE INVERT ELEVATION = TOP OF CAST IN PLACE BASE (4" ABOVE TOP OF OD OF HIGHEST PIPE).
VAC TEST REQ'D

ID	Description	Product No	Hgt	Qty	Weight
A	EJ 2400A Cover Sewer Knobby	9000100000660	.00	1	148
B	EJ 2420Z2 Ring 8"	9000100000713	.71	1	149
C	24x4 Interlock Adjusting Ring	909010024040A	.33	1	160
D	48x2.5 24 Ecc Cone PHS S	204809V2100000025	2.50	1	2,370
E	48x4.0 BBL PHS S	204801V0100000040	4.00	1	3,480
F	48x4.0 BBL FB PHS S	204801V5100000040	4.00	1	3,480
G	Unknown		.00	1	0
Total Weight (lbs)					9,787

Misc. Items	
Description	Qty
Gasket PHS 48 inch SSMH	2
Joint Seal CS102 1X14.5	1

Production Use	
Mfg. Date:	
Ship Date:	
Frame/Ring:	
Grate/Cover:	
PREPOUR:	
POSTPOUR:	



9455 Boston Ct.
 Henderson, CO 80640
 Phone: (303) 853-8053
 Fax:
 www.ForterraBP.com

Contractor: JBS Pipeline Contractors, CO
Project: Trails at Crowfoot F2 (DR HORTON)
Location: CO Parker
Order Nbr: 9419134MH1
Remarks: ASTM C478

Sanitary Sewer
48" (I.D.) Manhole
SA TC-SSMH-38

Date: 07/31/2019
 Plant: 155 Henderson Precast
 Coordinator: Chris Hoganson

Design Build Height		
Top of Casting	+	6096.48
Outlet Invert	-	6085.58
Wall Thk/Inv Adj	+	.14
Design Height	=	11.04
Casting/Adj Ring	-	1.04
Manhole Hgt	=	10.00

Stack Build Height		
Casting	+	.71
Adjusting Ring	+	.33
Cone	+	2.00
Riser	+	8.00
Base Thickness	+	.00
Outside Height	=	11.04

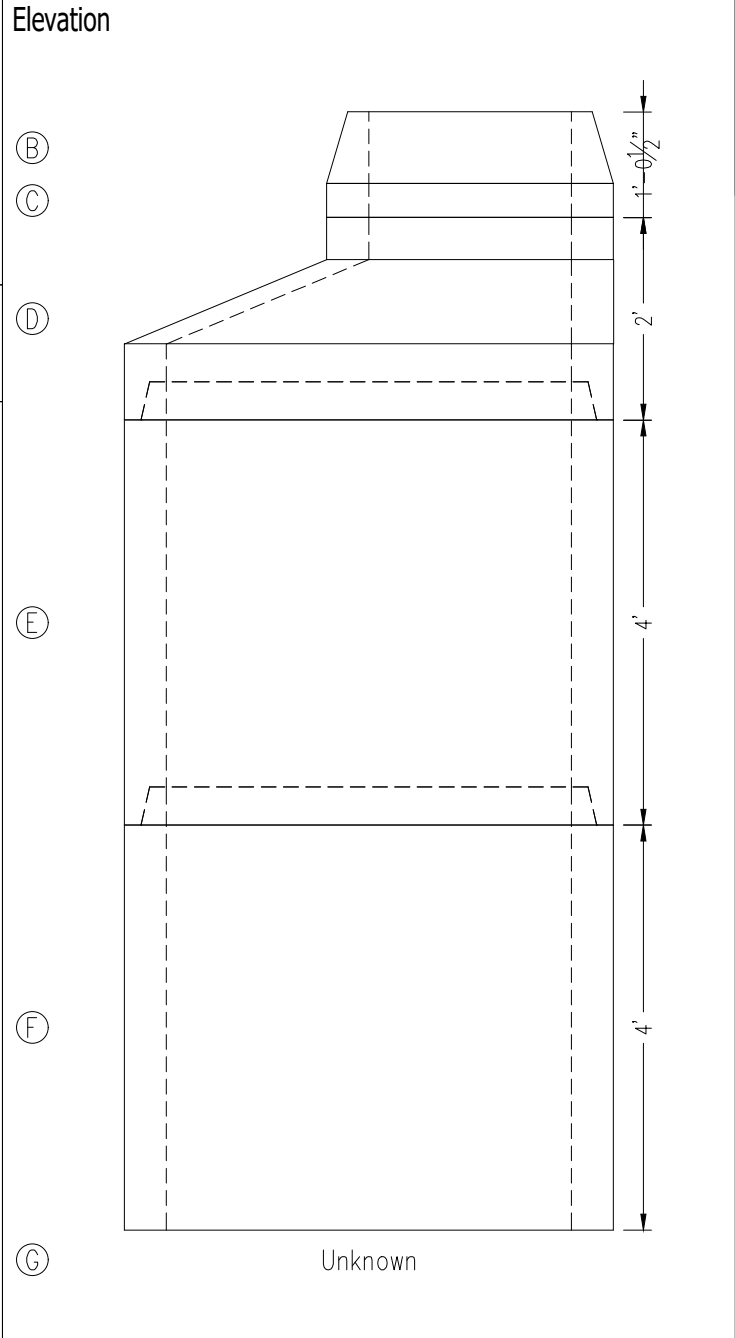

Opening Schedule								(HF=Hole Former, DO=Dig Out)			
ID	Pipe Size	Invert	Invert Up	Pipe O.D.	Opening/Connector	Top of Hole Up	C-Line Hole Up	Btm of Hole Up			

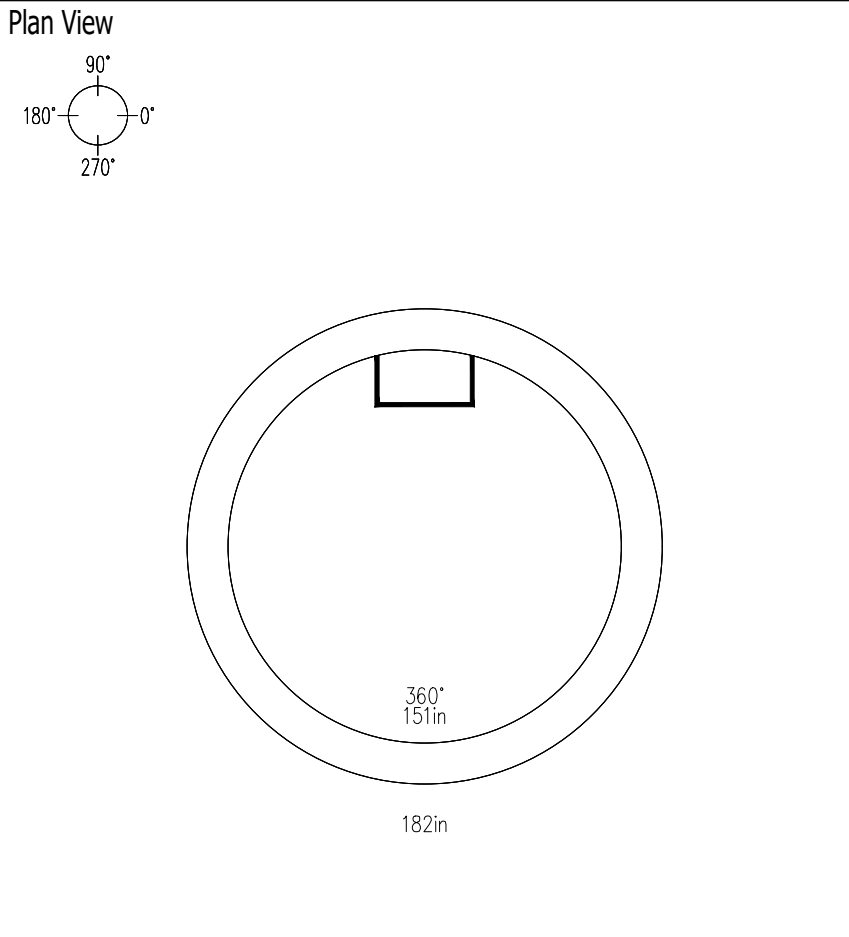

Notes
 PIPE INVERT ELEVATION = TOP OF CAST IN PLACE BASE (4" ABOVE TOP OF OD OF HIGHEST PIPE).
 VAC TEST REQ'D

Steps: 12" On Center 90°

Item List					
ID	Description	Product No	Hgt	Qty	Weight
A	EJ 2400A Cover Sewer Knobby	9000100000660	.00	1	148
B	EJ 2420Z2 Ring 8"	9000100000713	.71	1	149
C	24x4 Interlock Adjusting Ring	909010024040A	.33	1	160
D	48x2.0 24 Ecc Cone PHS S	204809V2100000020	2.00	1	1,650
E	48x4.0 BBL PHS S	204801V0100000040	4.00	1	3,480
F	48x4.0 BBL FB PHS S	204801V5100000040	4.00	1	3,480
G	Unknown		.00	1	0
Total Weight (lbs)					9,067

Misc. Items	
Description	Qty
Gasket PHS 48 inch SSMH	2
Joint Seal CS102 1X14.5	1

Production Use	
Mfg. Date:	
Ship Date:	
Frame/Ring:	
Grate/Cover:	
PREPOUR:	
POSTPOUR:	

Design Build Height			Stack Build Height		
Top of Casting	+	6045.98	Casting	+	.71
Outlet Invert	-	6034.48	Adjusting Ring	+	.42
Wall Thk/Inv Adj	+	.14	Cone	+	2.50
Design Height	=	11.64	Riser	+	8.00
Casting/Adj Ring	-	1.13	Base Thickness	+	.00
Manhole Hgt	=	10.52	Outside Height	=	11.63

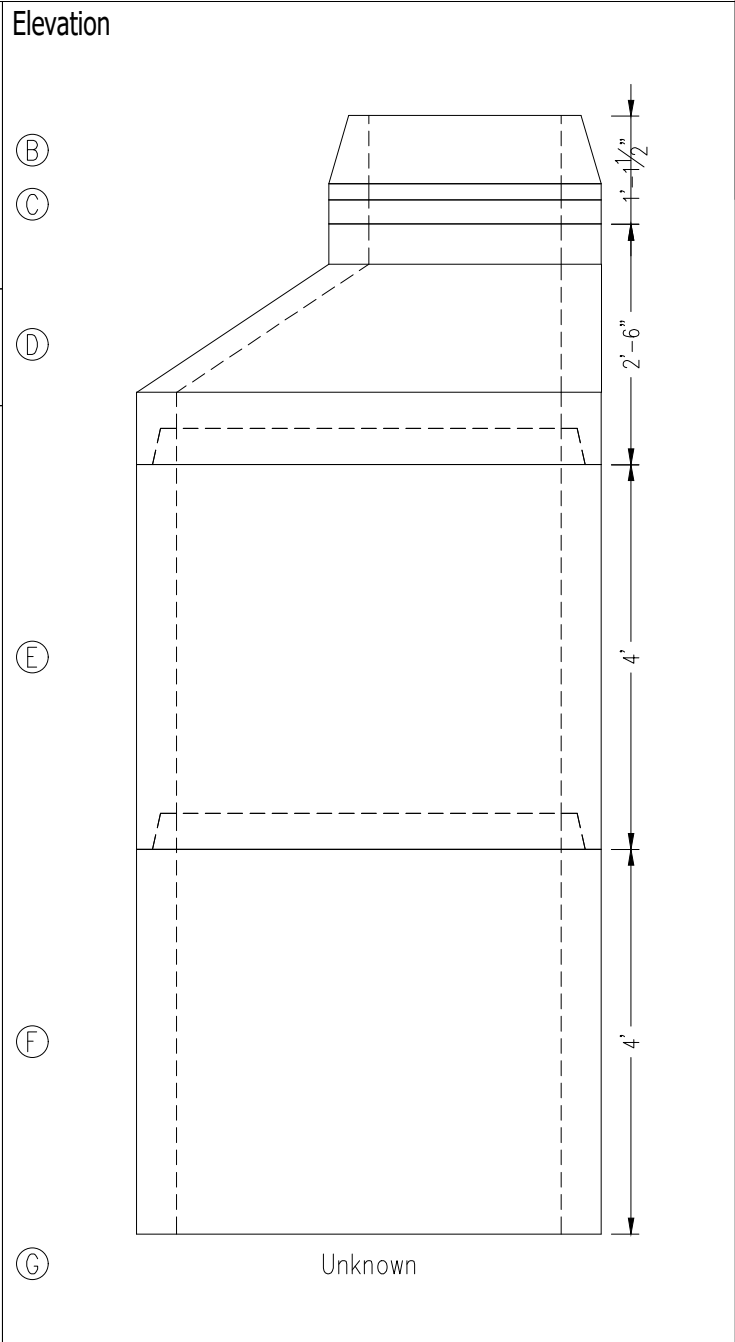

Opening Schedule (HF=Hole Former, DO=Dig Out)

ID	Pipe Size	Invert	Pipe Up	Opening/ O.D.	Connector	Top of Hole Up	C-Line Hole Up	Btm of Hole Up

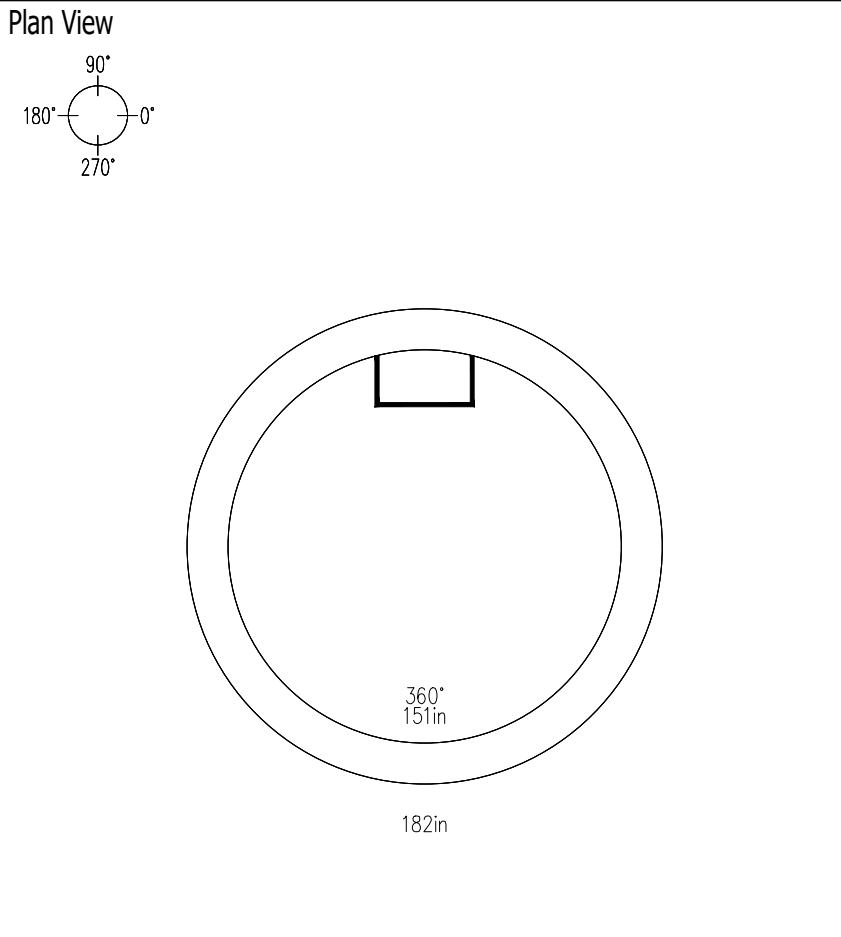

Notes
PIPE INVERT ELEVATION = TOP OF CAST IN PLACE BASE (4" ABOVE TOP OF OD OF HIGHEST PIPE).
VAC TEST REQ'D

Steps: 12" On Center 90°

ID	Description	Product No	Hgt	Qty	Weight
A	EJ 2400A Cover Sewer Knobby	9000100000660	.00	1	148
B	EJ 2420Z2 Ring 8"	9000100000713	.71	1	149
C	24x2 Interlock Adjusting Ring	909010024020A	.17	1	80
C	24x3 Interlock Adjusting Ring	909010024030A	.25	1	120
D	48x2.5 24 Ecc Cone PHS S	204809V2100000025	2.50	1	2,370
E	48x4.0 BBL PHS S	204801V0100000040	4.00	1	3,480
F	48x4.0 BBL FB PHS S	204801V5100000040	4.00	1	3,480
G	Unknown		.00	1	0
Total Weight (lbs)					9,827

Misc. Items	
Description	Qty
Gasket PHS 48 inch SSMH	2
Joint Seal CS102 1X14.5	1

Production Use	
Mfg. Date:	
Ship Date:	
Frame/Ring:	
Grate/Cover:	
PREPOUR:	
POSTPOUR:	



9455 Boston Ct.
 Henderson, CO 80640
 Phone: (303) 853-8053
 Fax:
 www.ForterraBP.com

Contractor: JBS Pipeline Contractors, CO
Project: Trails at Crowfoot F2 (DR HORTON)
Location: CO Parker
Order Nbr: 9419134MH1
Remarks: ASTM C478

Sanitary Sewer
48" (I.D.) Manhole
SA TC-SSMH-48
 Date: 07/31/2019
 Plant: 155 Henderson Precast
 Coordinator: Chris Hoganson

Design Build Height			Stack Build Height		
Top of Casting	+	6047.62	Casting	+	.71
Outlet Invert	-	6036.38	Adjusting Ring	+	.17
Wall Thk/Inv Adj	+	.14	Cone	+	2.50
Design Height	=	11.38	Riser	+	8.00
Casting/Adj Ring	-	.88	Base Thickness	+	.00
Manhole Hgt	=	10.50	Outside Height	=	11.38

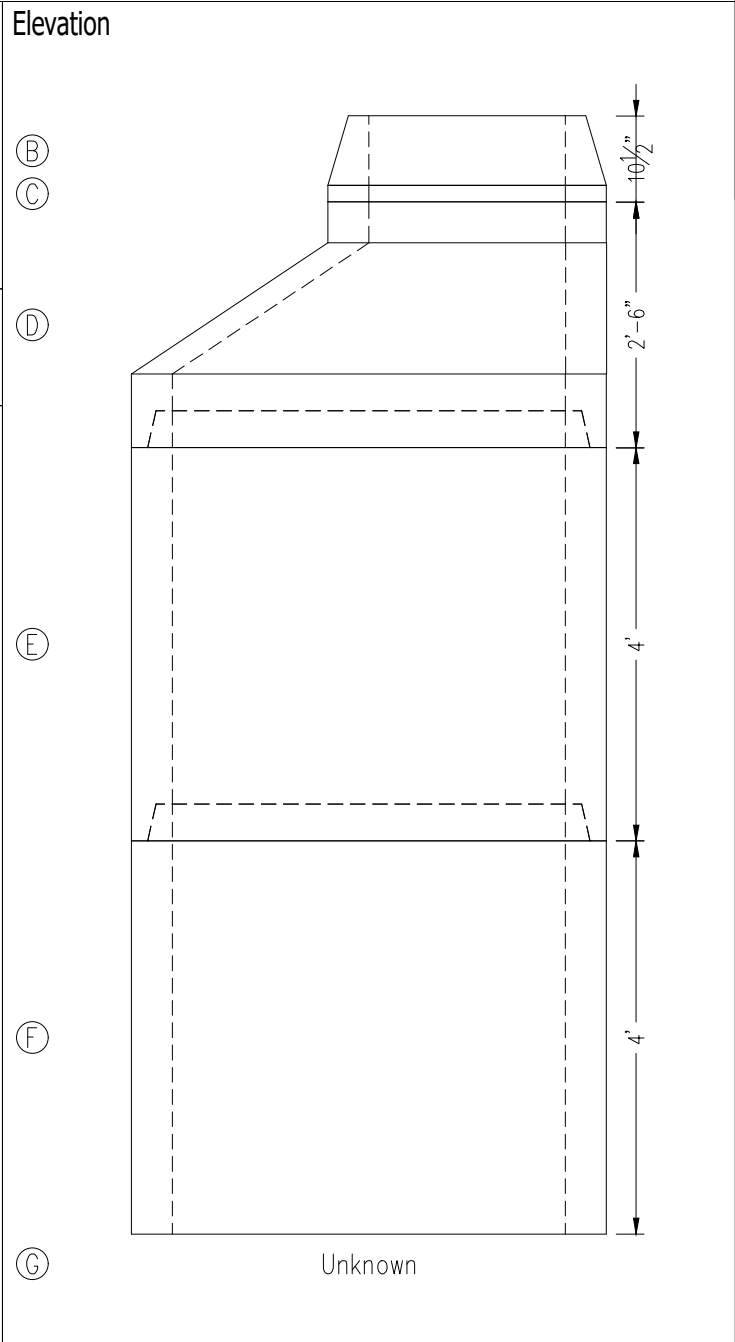

Opening Schedule (HF=Hole Former, DO=Dig Out)

ID	Pipe Size	Invert	Pipe Up	Opening/ O.D.	Connector	Top of Hole Up	C-Line Hole Up	Btm of Hole Up

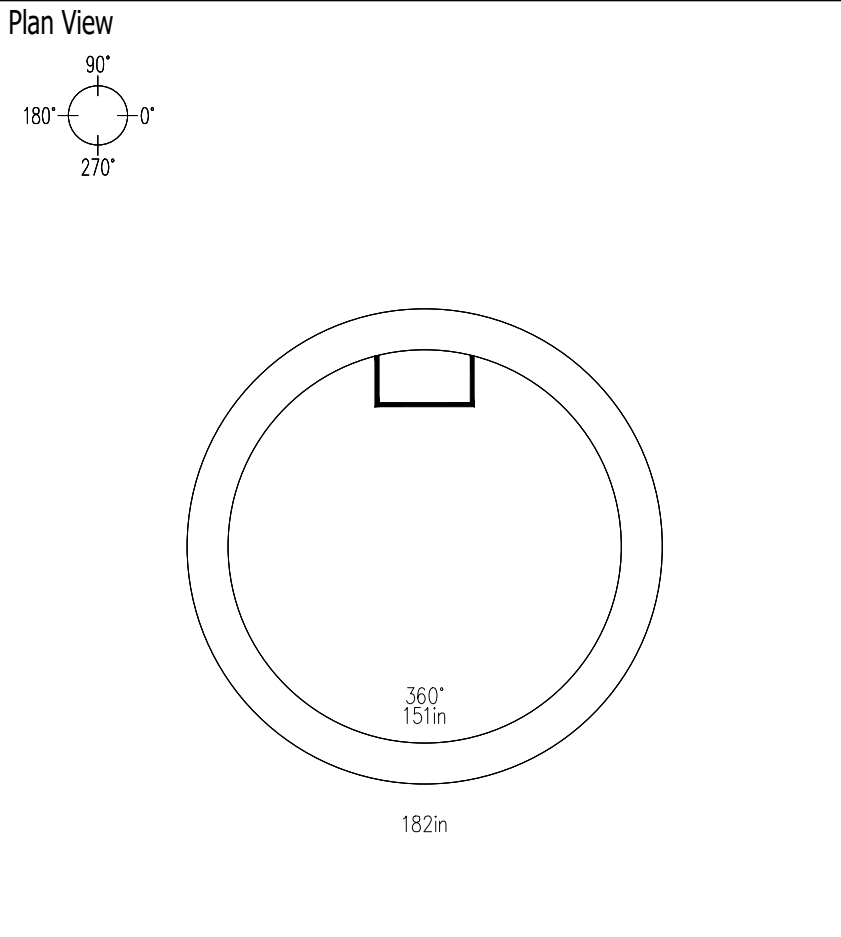

Notes
 PIPE INVERT ELEVATION = TOP OF CAST IN PLACE BASE (4" ABOVE TOP OF OD OF HIGHEST PIPE).
 VAC TEST REQ'D

Steps: 12" On Center 90°

ID	Description	Product No	Hgt	Qty	Weight
A	EJ 2400A Cover Sewer Knobby	9000100000660	.00	1	148
B	EJ 2420Z2 Ring 8"	9000100000713	.71	1	149
C	24x2 Interlock Adjusting Ring	909010024020A	.17	1	80
D	48x2.5 24 Ecc Cone PHS S	204809V2100000025	2.50	1	2,370
E	48x4.0 BBL PHS S	204801V0100000040	4.00	1	3,480
F	48x4.0 BBL FB PHS S	204801V5100000040	4.00	1	3,480
G	Unknown		.00	1	0
Total Weight (lbs)					9,707

Misc. Items	Qty	Production Use
Description		Mfg. Date:
Gasket PHS 48 inch SSMH	2	Ship Date:
Joint Seal CS102 1X14.5	1	Frame/Ring:
		Grate/Cover:
		PREPOUR:
		POSTPOUR:



9455 Boston Ct.
 Henderson, CO 80640
 Phone: (303) 853-8053
 Fax:
 www.ForterraBP.com

Contractor: JBS Pipeline Contractors, CO
Project: Trails at Crowfoot F2 (DR HORTON)
Location: CO Parker
Order Nbr: 9419134MH1
Remarks: ASTM C478

Sanitary Sewer
48" (I.D.) Manhole
SA TC-SSMH-50
 Date: 07/31/2019
 Plant: 155 Henderson Precast
 Coordinator: Chris Hoganson

Design Build Height	
Top of Casting	+ 6048.31
Outlet Invert	- 6037.30
Wall Thk/Inv Adj	+ .14
Design Height	= 11.15
Casting/Adj Ring	- 1.13
Manhole Hgt	= 10.03

Stack Build Height	
Casting	+ .71
Adjusting Ring	+ .42
Cone	+ 2.00
Riser	+ 8.00
Base Thickness	+ .00
Outside Height	= 11.13

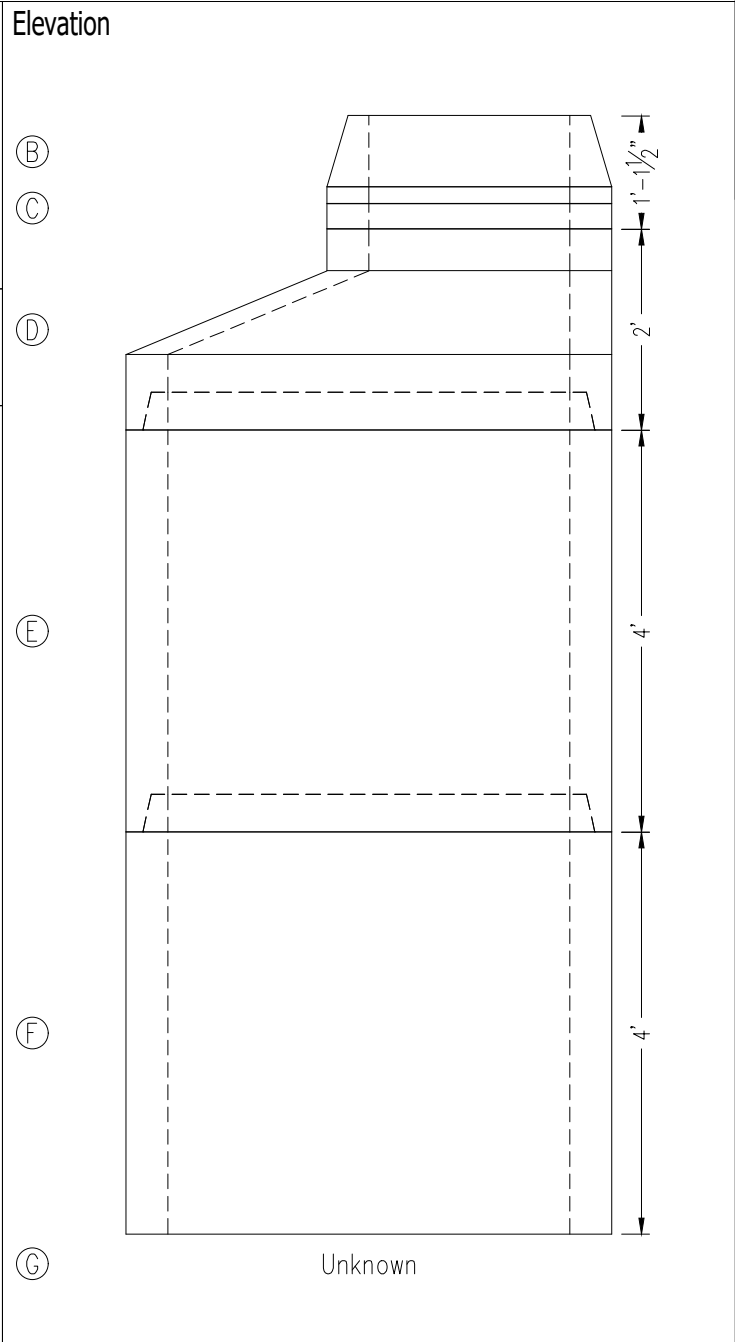

Opening Schedule								(HF=Hole Former, DO=Dig Out)
ID	Pipe Size	Invert	Pipe Up	Opening/ O.D.	Connector	Top of Hole Up	C-Line Hole Up	Btm of Hole Up

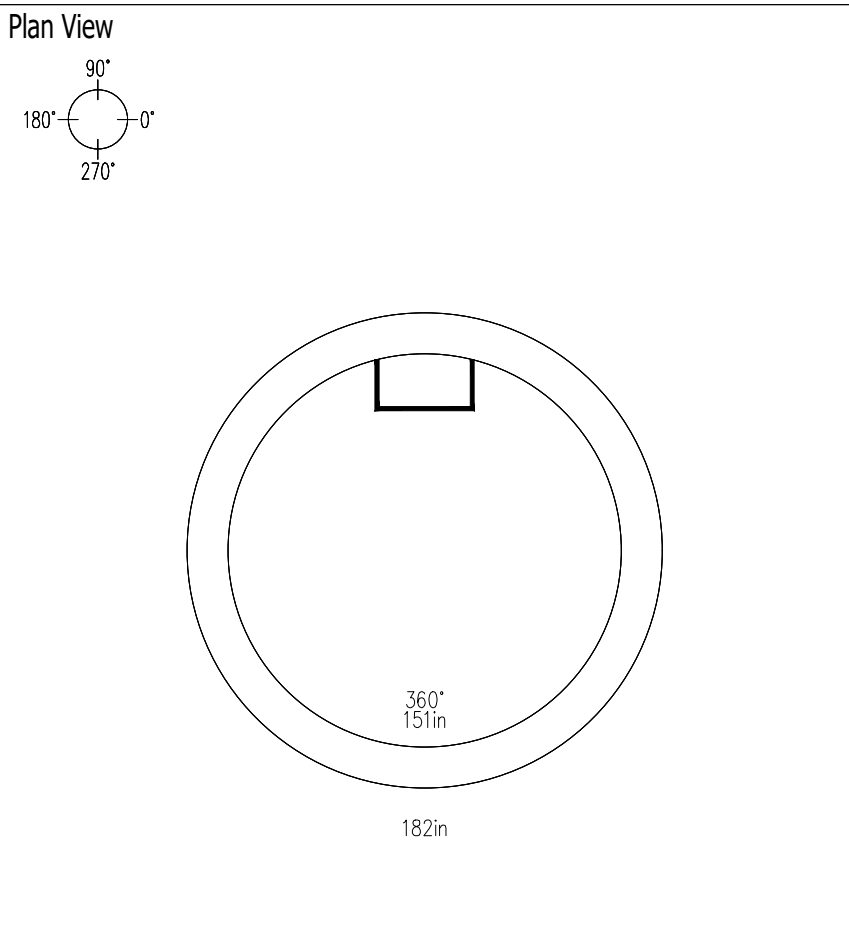

Notes
 PIPE INVERT ELEVATION = TOP OF CAST IN PLACE BASE (4" ABOVE TOP OF OD OF HIGHEST PIPE).
 VAC TEST REQ'D

Steps: 12" On Center 90°

ID	Description	Product No	Hgt	Qty	Weight
A	EJ 2400A Cover Sewer Knobby	9000100000660	.00	1	148
B	EJ 2420Z2 Ring 8"	9000100000713	.71	1	149
C	24x2 Interlock Adjusting Ring	909010024020A	.17	1	80
C	24x3 Interlock Adjusting Ring	909010024030A	.25	1	120
D	48x2.0 24 Ecc Cone PHS S	204809V2100000020	2.00	1	1,650
E	48x4.0 BBL PHS S	204801V0100000040	4.00	1	3,480
F	48x4.0 BBL FB PHS S	204801V5100000040	4.00	1	3,480
G	Unknown		.00	1	0
Total Weight (lbs)					9,107

Misc. Items	
Description	Qty
Gasket PHS 48 inch SSMH	2
Joint Seal CS102 1X14.5	1

Production Use	
Mfg. Date:	
Ship Date:	
Frame/Ring:	
Grate/Cover:	
PREPOUR:	
POSTPOUR:	



9455 Boston Ct.
Henderson, CO 80640
Phone: (303) 853-8053
Fax:
www.ForterraBP.com

Contractor: JBS Pipeline Contractors, CO
Project: Trails at Crowfoot F2 (DR HORTON)
Location: CO Parker
Order Nbr: 9419134MH1
Remarks: ASTM C478

Sanitary Sewer
48" (I.D.) Manhole
SA TC-SSMH-51

Date: 07/31/2019
Plant: 155 Henderson Precast
Coordinator: Chris Hoganson

Design Build Height	
Top of Casting	+ 6049.03
Outlet Invert	- 6037.95
Wall Thk/Inv Adj	+ .14
Design Height	= 11.22
Casting/Adj Ring	- .71
Manhole Hgt	= 10.51

Stack Build Height	
Casting	+ .71
Cone	+ 2.50
Riser	+ 8.00
Base Thickness	+ .00
Outside Height	= 11.21

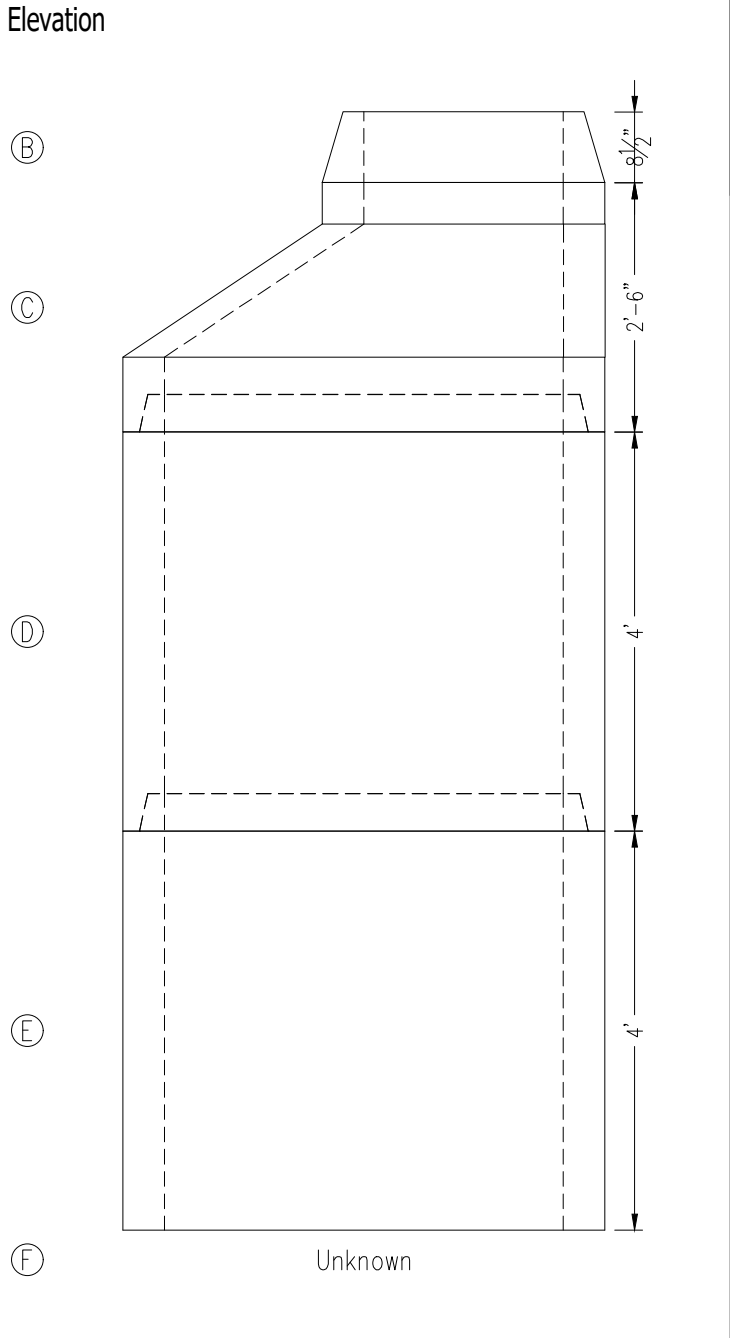

Opening Schedule								(HF=Hole Former, DO=Dig Out)
ID	Pipe Size	Invert	Pipe Up	Opening/ O.D.	Connector	Top of Hole Up	C-Line Hole Up	Btm of Hole Up

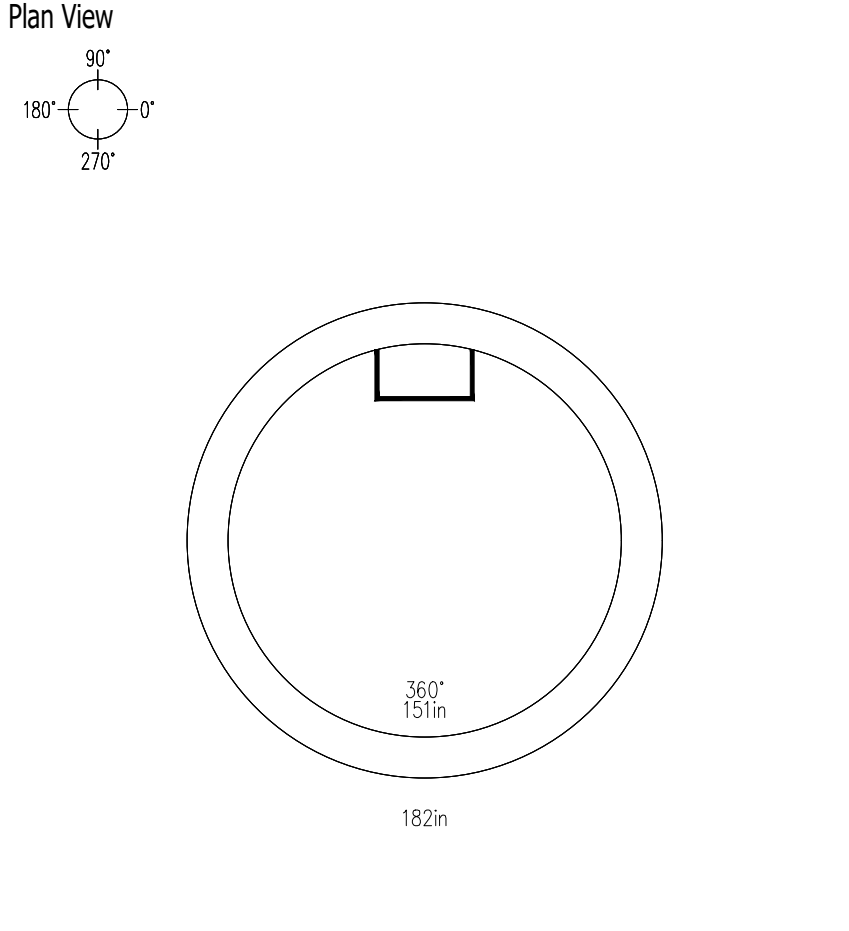

Steps: 12" On Center 90°

Notes
PIPE INVERT ELEVATION = TOP OF CAST IN PLACE BASE (4" ABOVE TOP OF OD OF HIGHEST PIPE).
VAC TEST REQ'D

Item List					
ID	Description	Product No	Hgt	Qty	Weight
A	EJ 2400A Cover Sewer Knobby	9000100000660	.00	1	148
B	EJ 2420Z2 Ring 8"	9000100000713	.71	1	149
C	48x2.5 24 Ecc Cone PHS S	204809V2100000025	2.50	1	2,370
D	48x4.0 BBL PHS S	204801V0100000040	4.00	1	3,480
E	48x4.0 BBL FB PHS S	204801V5100000040	4.00	1	3,480
F	Unknown		.00	1	0
Total Weight (lbs)					9,627

Misc. Items	
Description	Qty
Gasket PHS 48 inch SSMH	2
Joint Seal CS102 1X14.5	1

Production Use	
Mfg. Date:	
Ship Date:	
Frame/Ring:	
Grate/Cover:	
PREPOUR:	
POSTPOUR:	

Design Build Height	
Top of Casting	+ 6051.60
Outlet Invert	- 6040.14
Wall Thk/Inv Adj	+ .14
Design Height	= 11.60
Casting/Adj Ring	- 1.04
Manhole Hgt	= 10.56

Stack Build Height	
Casting	+ .71
Adjusting Ring	+ .33
Cone	+ 2.50
Riser	+ 8.00
Base Thickness	+ .00
Outside Height	= 11.54

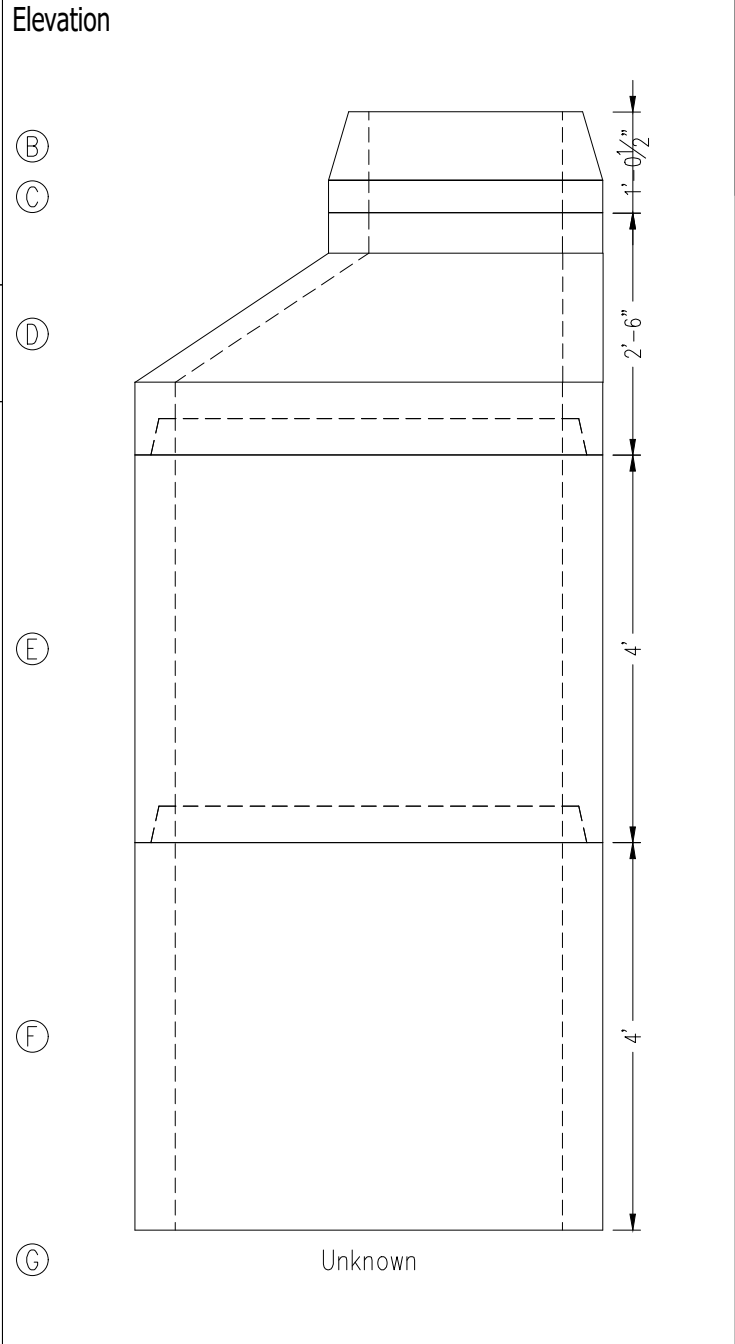

Opening Schedule								(HF=Hole Former, DO=Dig Out)	
ID	Pipe Size	Invert	Invert Up	Pipe O.D.	Opening/ Connector	Top of Hole Up	C-Line Hole Up	Btm of Hole Up	

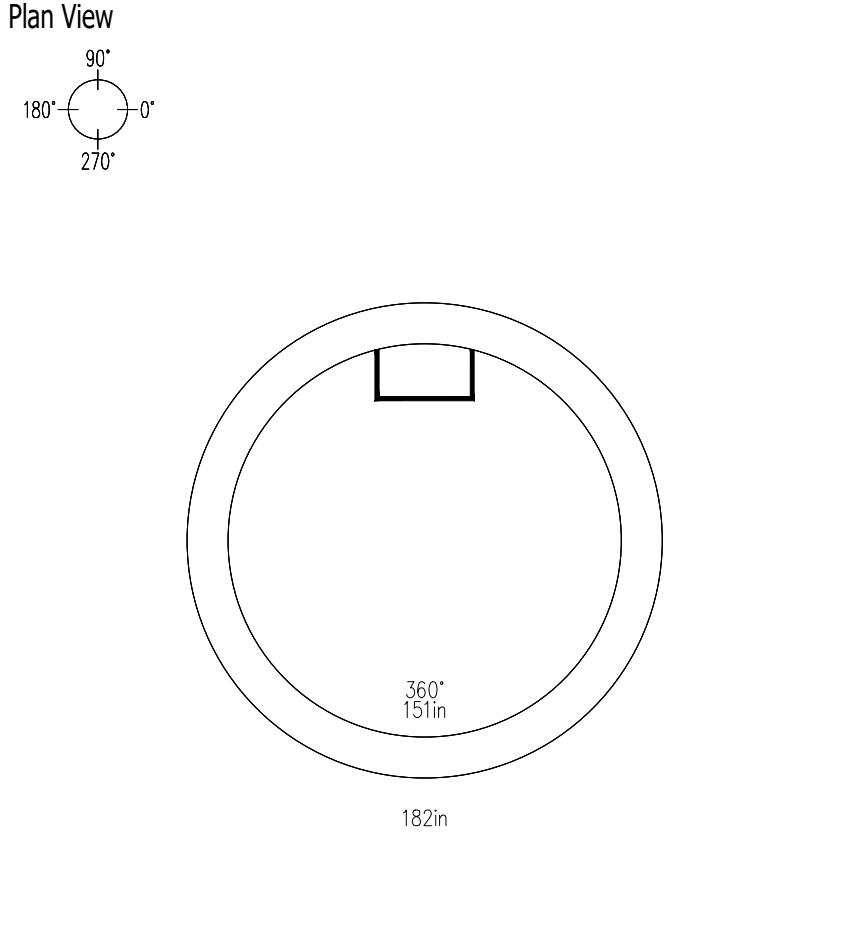

Notes
PIPE INVERT ELEVATION = TOP OF CAST IN PLACE BASE (4" ABOVE TOP OF OD OF HIGHEST PIPE).
VAC TEST REQ'D

Steps: 12" On Center 90°

Item List					
ID	Description	Product No	Hgt	Qty	Weight
A	EJ 2400A Cover Sewer Knobby	9000100000660	.00	1	148
B	EJ 2420Z2 Ring 8"	9000100000713	.71	1	149
C	24x4 Interlock Adjusting Ring	909010024040A	.33	1	160
D	48x2.5 24 Ecc Cone PHS S	204809V2100000025	2.50	1	2,370
E	48x4.0 BBL PHS S	204801V0100000040	4.00	1	3,480
F	48x4.0 BBL FB PHS S	204801V5100000040	4.00	1	3,480
G	Unknown		.00	1	0
Total Weight (lbs)					9,787

Misc. Items	
Description	Qty
Gasket PHS 48 inch SSMH	2
Joint Seal CS102 1X14.5	1

Production Use	
Mfg. Date:	
Ship Date:	
Frame/Ring:	
Grate/Cover:	
PREPOUR:	
POSTPOUR:	

Design Build Height			Stack Build Height		
Top of Casting	+	6071.82	Casting	+	.71
Outlet Invert	-	6060.82	Adjusting Ring	+	.42
Wall Thk/Inv Adj	+	.14	Cone	+	2.00
Design Height	=	11.14	Riser	+	8.00
Casting/Adj Ring	-	1.13	Base Thickness	+	.00
Manhole Hgt	=	10.02	Outside Height	=	11.13

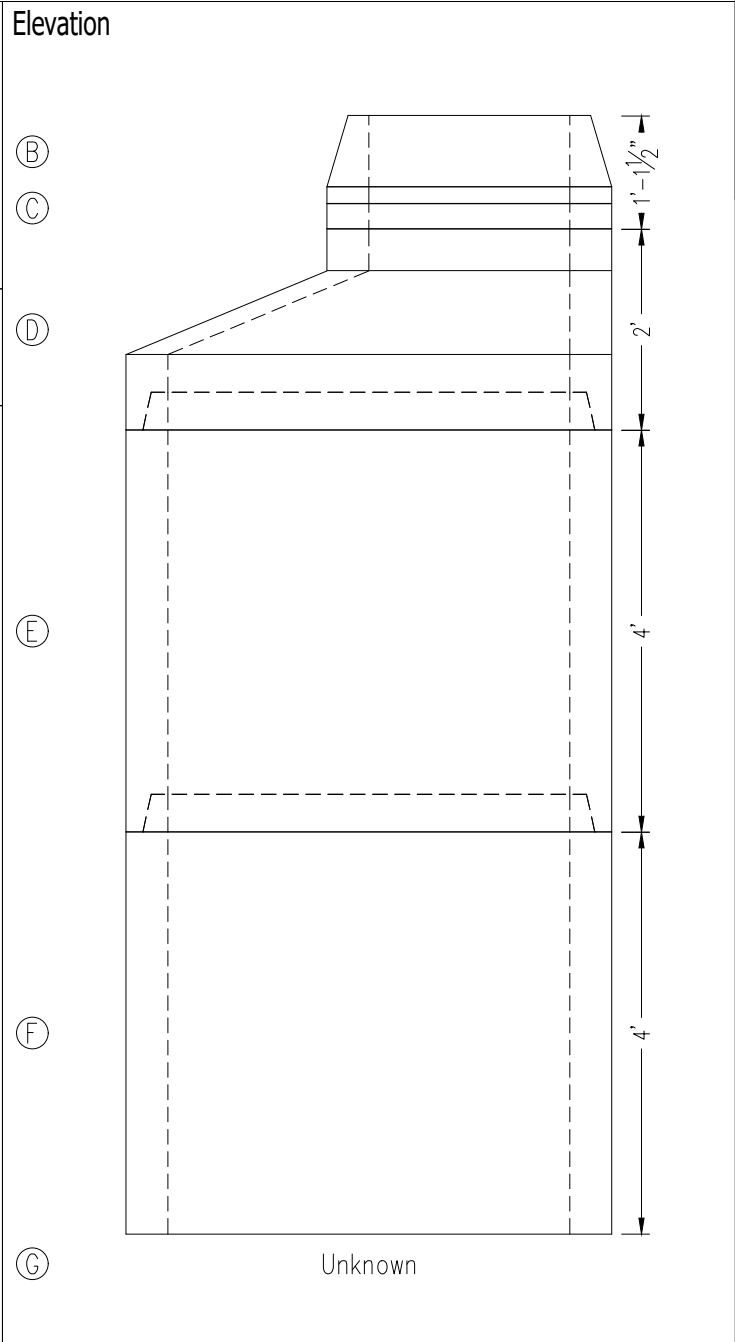

Opening Schedule (HF=Hole Former, DO=Dig Out)

ID	Pipe Size	Invert	Pipe Up	Opening/ O.D.	Connector	Top of Hole Up	C-Line Hole Up	Btm of Hole Up

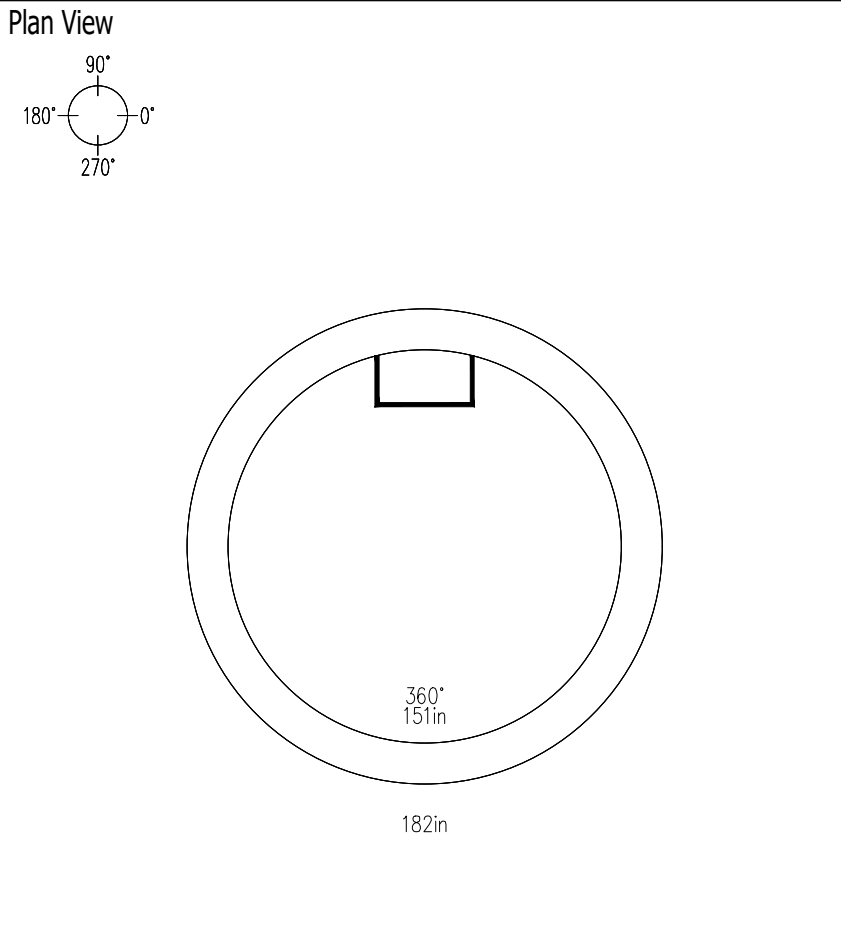

Notes
PIPE INVERT ELEVATION = TOP OF CAST IN PLACE BASE (4" ABOVE TOP OF OD OF HIGHEST PIPE).
VAC TEST REQ'D

Steps: 12" On Center 90°

ID	Description	Product No	Hgt	Qty	Weight
A	EJ 2400A Cover Sewer Knobby	9000100000660	.00	1	148
B	EJ 2420Z2 Ring 8"	9000100000713	.71	1	149
C	24x2 Interlock Adjusting Ring	909010024020A	.17	1	80
C	24x3 Interlock Adjusting Ring	909010024030A	.25	1	120
D	48x2.0 24 Ecc Cone PHS S	204809V2100000020	2.00	1	1,650
E	48x4.0 BBL PHS S	204801V0100000040	4.00	1	3,480
F	48x4.0 BBL FB PHS S	204801V5100000040	4.00	1	3,480
G	Unknown		.00	1	0
Total Weight (lbs)					9,107

Misc. Items	
Description	Qty
Gasket PHS 48 inch SSMH	2
Joint Seal CS102 1X14.5	1

Production Use	
Mfg. Date:	
Ship Date:	
Frame/Ring:	
Grate/Cover:	
PREPOUR:	
POSTPOUR:	



9455 Boston Ct.
Henderson, CO 80640
Phone: (303) 853-8053
Fax:
www.ForterraBP.com

Contractor: JBS Pipeline Contractors, CO
Project: Trails at Crowfoot F2 (DR HORTON)
Location: CO Parker
Order Nbr: 9419134MH1
Remarks: ASTM C478

Sanitary Sewer
48" (I.D.) Manhole
SA TC-SSMH-54
Date: 07/31/2019
Plant: 155 Henderson Precast
Coordinator: Chris Hoganson

Design Build Height	
Top of Casting	+ 6091.62
Outlet Invert	- 6080.61
Wall Thk/Inv Adj	+ .14
Design Height	= 11.15
Casting/Adj Ring	- 1.13
Manhole Hgt	= 10.03

Stack Build Height	
Casting	+ .71
Adjusting Ring	+ .42
Cone	+ 2.00
Riser	+ 8.00
Base Thickness	+ .00
Outside Height	= 11.13

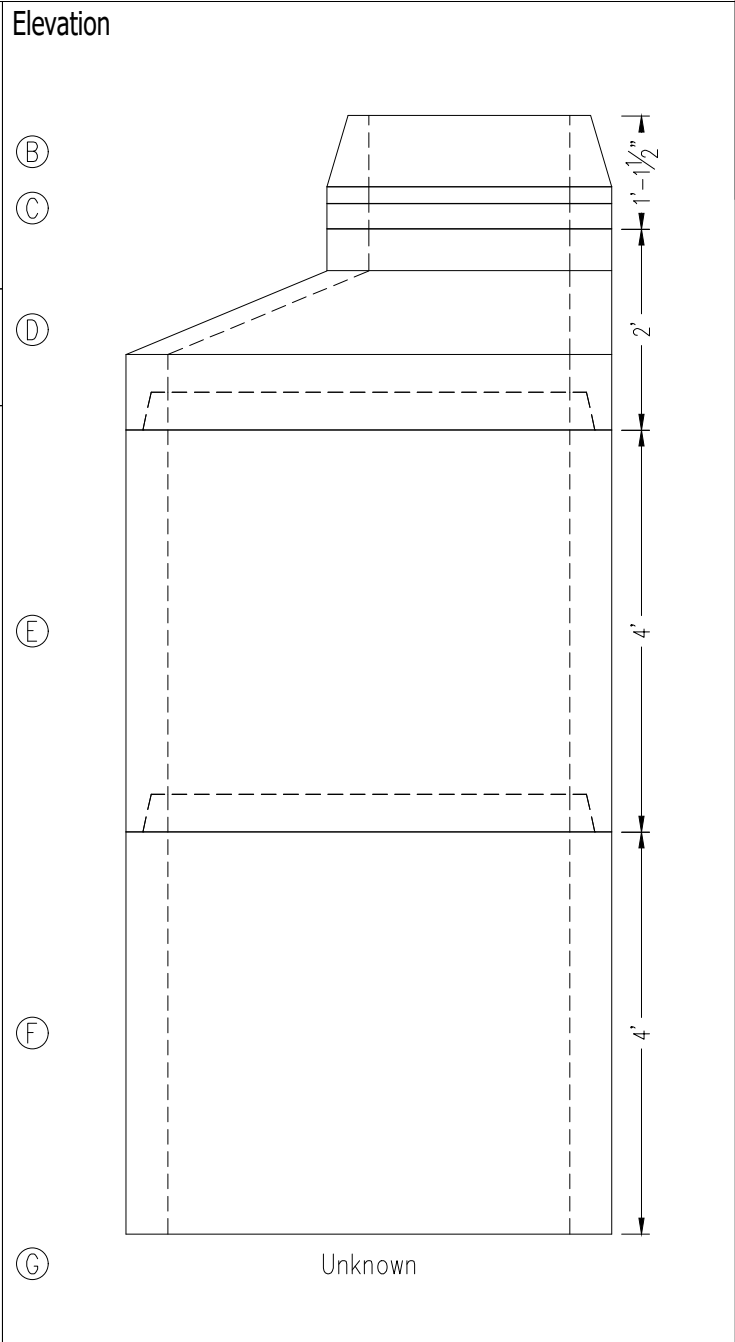

Opening Schedule								(HF=Hole Former, DO=Dig Out)
ID	Pipe Size	Invert	Pipe Up	Opening/ O.D.	Connector	Top of Hole Up	C-Line Hole Up	Btm of Hole Up

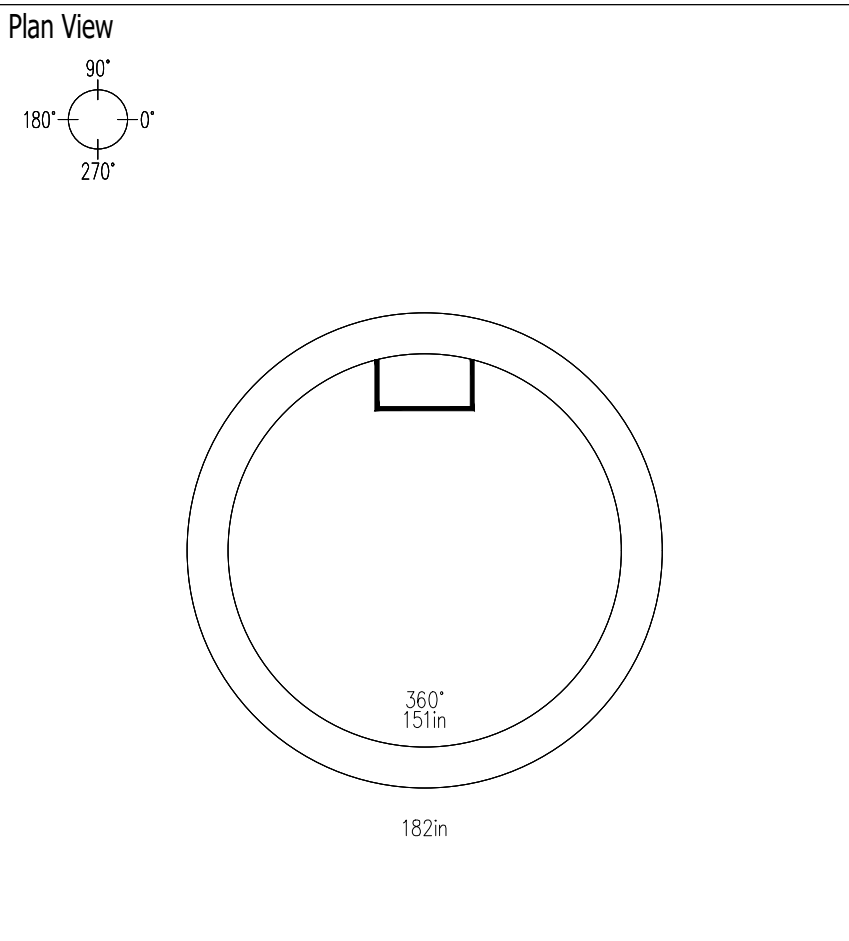

Notes
PIPE INVERT ELEVATION = TOP OF CAST IN PLACE BASE (4" ABOVE TOP OF OD OF HIGHEST PIPE).
VAC TEST REQ'D

Steps: 12" On Center 90°

ID	Description	Product No	Hgt	Qty	Weight
A	EJ 2400A Cover Sewer Knobby	9000100000660	.00	1	148
B	EJ 2420Z2 Ring 8"	9000100000713	.71	1	149
C	24x2 Interlock Adjusting Ring	909010024020A	.17	1	80
C	24x3 Interlock Adjusting Ring	909010024030A	.25	1	120
D	48x2.0 24 Ecc Cone PHS S	204809V2100000020	2.00	1	1,650
E	48x4.0 BBL PHS S	204801V0100000040	4.00	1	3,480
F	48x4.0 BBL FB PHS S	204801V5100000040	4.00	1	3,480
G	Unknown		.00	1	0
Total Weight (lbs)					9,107

Misc. Items	Qty
Description	
Gasket PHS 48 inch SSMH	2
Joint Seal CS102 1X14.5	1

Production Use	
Mfg. Date:	
Ship Date:	
Frame/Ring:	
Grate/Cover:	
PREPOUR:	
POSTPOUR:	



9455 Boston Ct.
Henderson, CO 80640
Phone: (303) 853-8053
Fax:
www.ForterraBP.com

Contractor: JBS Pipeline Contractors, CO
Project: Trails at Crowfoot F2 (DR HORTON)
Location: CO Parker
Order Nbr: 9419134MH1
Remarks: ASTM C478

Sanitary Sewer
48" (I.D.) Manhole
SA TC-SSMH-61
Date: 07/31/2019
Plant: 155 Henderson Precast
Coordinator: Chris Hoganson

Design Build Height			Stack Build Height		
Top of Casting	+	6095.29	Casting	+	.71
Outlet Invert	-	6083.30	Adjusting Ring	+	.42
Wall Thk/Inv Adj	+	.14	Cone	+	3.00
Design Height	=	12.13	Riser	+	8.00
Casting/Adj Ring	-	1.13	Base Thickness	+	.00
Manhole Hgt	=	11.00	Outside Height	=	12.13

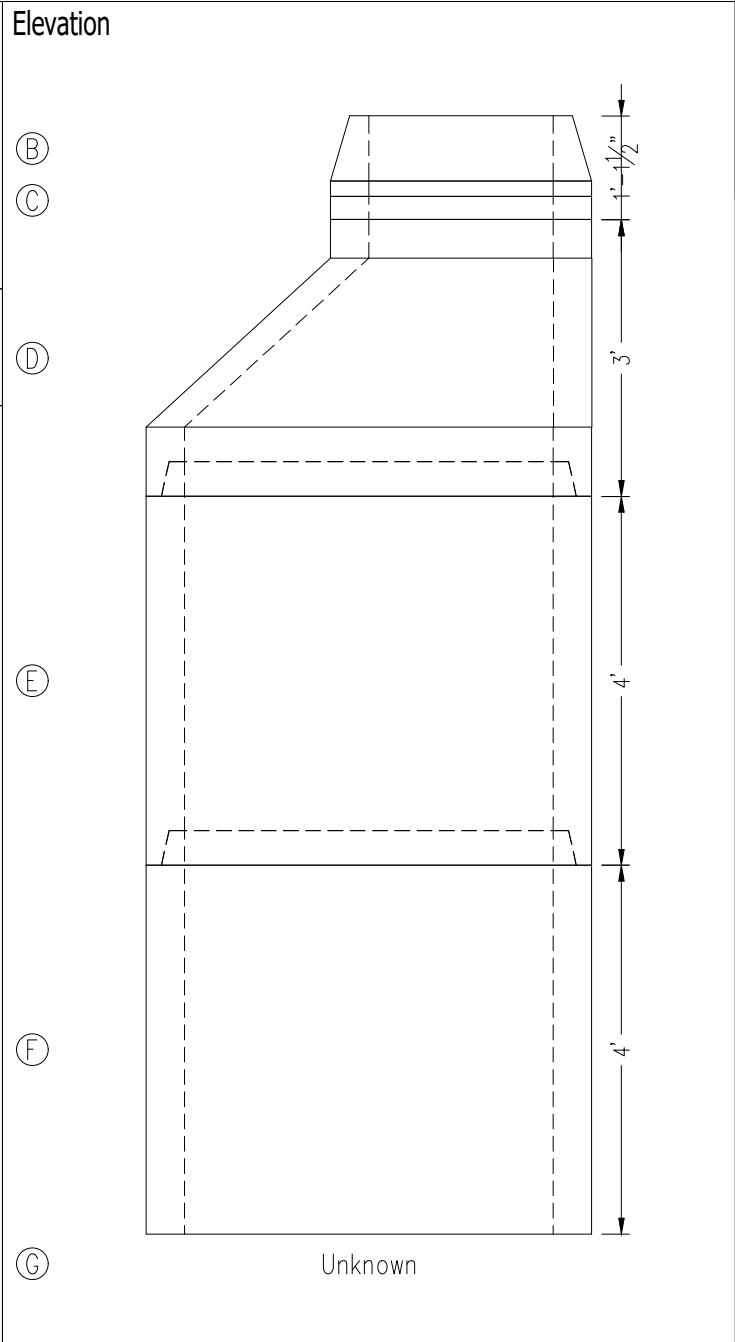

Opening Schedule (HF=Hole Former, DO=Dig Out)

ID	Pipe Size	Invert	Invert Up	Pipe O.D.	Opening/Connector	Top of Hole Up	C-Line Hole Up	Btm of Hole Up

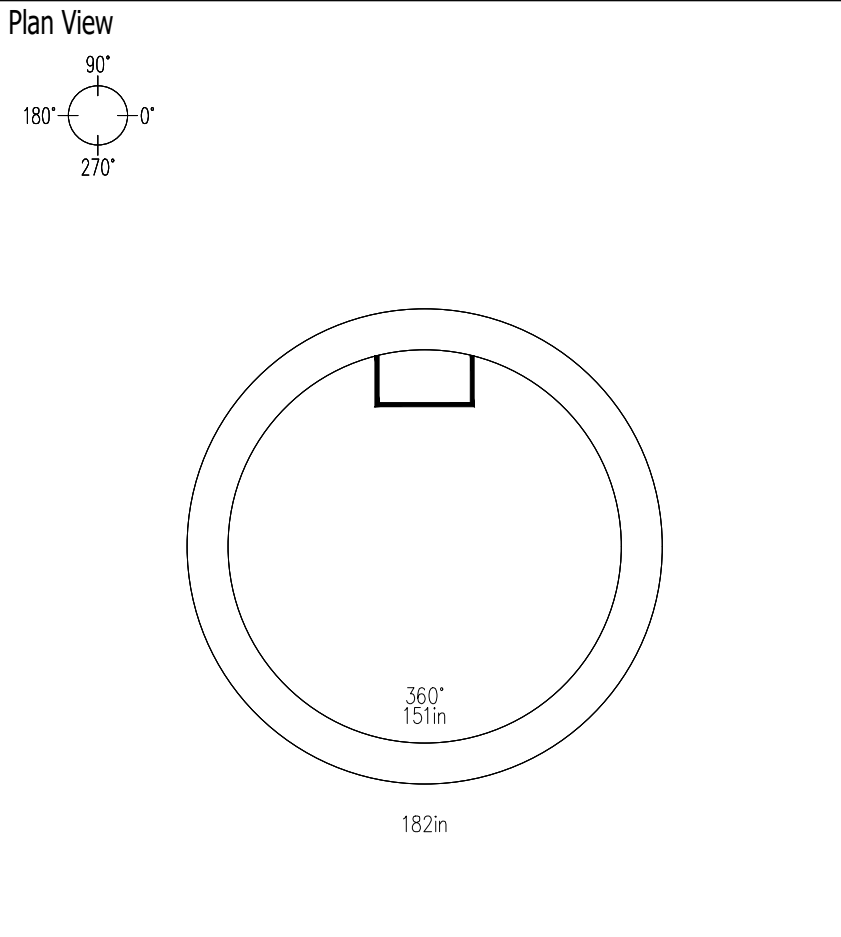

Notes
PIPE INVERT ELEVATION = TOP OF CAST IN PLACE BASE (4" ABOVE TOP OF OD OF HIGHEST PIPE).
VAC TEST REQ'D

Steps: 12" On Center 90°

ID	Description	Product No	Hgt	Qty	Weight
A	EJ 2400A Cover Sewer Knobby	9000100000660	.00	1	148
B	EJ 2420Z2 Ring 8"	9000100000713	.71	1	149
C	24x2 Interlock Adjusting Ring	909010024020A	.17	1	80
C	24x3 Interlock Adjusting Ring	909010024030A	.25	1	120
D	48x3.0 24 Ecc Cone PHS S	204809V2100000030	3.00	1	2,900
E	48x4.0 BBL PHS S	204801V0100000040	4.00	1	3,480
F	48x4.0 BBL FB PHS S	204801V5100000040	4.00	1	3,480
G	Unknown		.00	1	0
Total Weight (lbs)					10,357

Misc. Items	
Description	Qty
Gasket PHS 48 inch SSMH	2
Joint Seal CS102 1X14.5	1

Production Use	
Mfg. Date:	
Ship Date:	
Frame/Ring:	
Grate/Cover:	
PREPOUR:	
POSTPOUR:	



9455 Boston Ct.
Henderson, CO 80640
Phone: (303) 853-8053
Fax:
www.ForterraBP.com

Contractor: JBS Pipeline Contractors, CO
Project: Trails at Crowfoot F2 (DR HORTON)
Location: CO Parker
Order Nbr: 9419134MH1
Remarks: ASTM C478

Sanitary Sewer
48" (I.D.) Manhole
SA TC-SSMH-62

Date: 07/31/2019
Plant: 155 Henderson Precast
Coordinator: Chris Hoganson

Design Build Height	
Top of Casting	+ 6099.26
Outlet Invert	- 6088.07
Wall Thk/Inv Adj	+ .14
Design Height	= 11.33
Casting/Adj Ring	- .71
Manhole Hgt	= 10.62

Stack Build Height	
Casting	+ .71
Cone	+ 2.50
Riser	+ 8.00
Base Thickness	+ .00
Outside Height	= 11.21

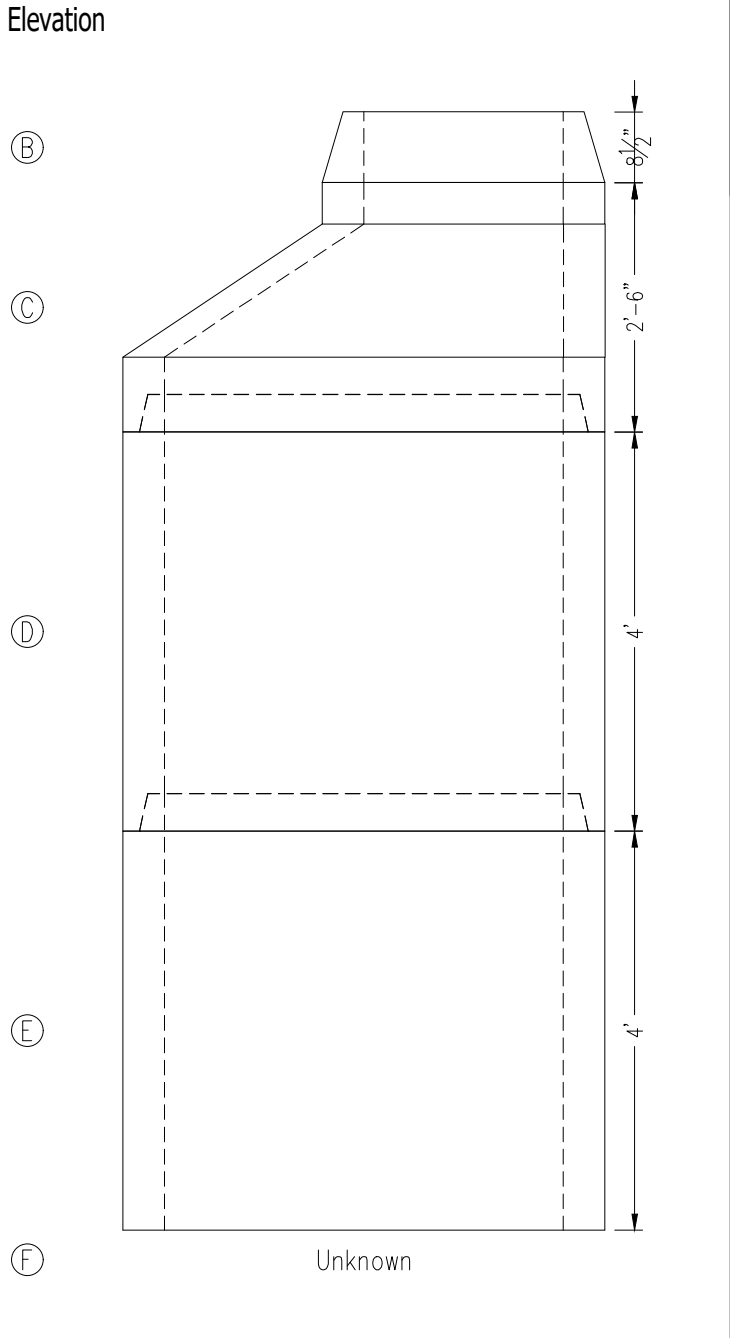

Opening Schedule								(HF=Hole Former, DO=Dig Out)
ID	Pipe Size	Invert	Invert Up	Pipe O.D.	Opening/Connector	Top of Hole Up	C-Line Hole Up	Btm of Hole Up

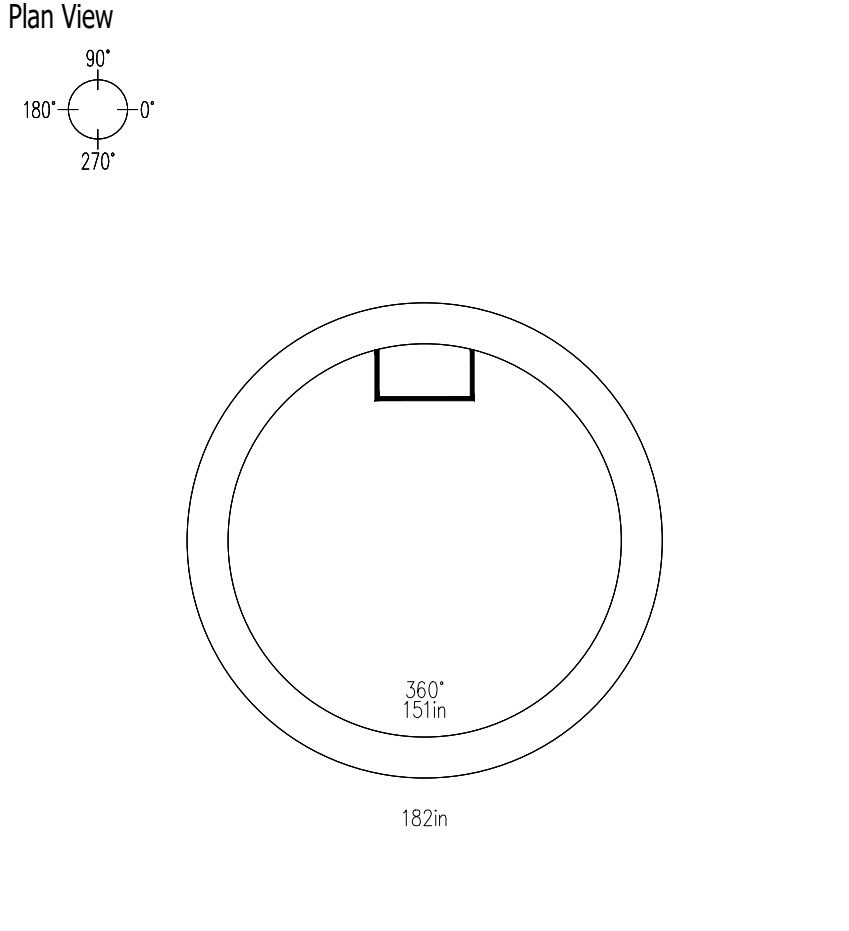

Notes
PIPE INVERT ELEVATION = TOP OF CAST IN PLACE BASE (4" ABOVE TOP OF OD OF HIGHEST PIPE).
VAC TEST REQ'D

Steps: 12" On Center 90°

Item List					
ID	Description	Product No	Hgt	Qty	Weight
A	EJ 2400A Cover Sewer Knobby	9000100000660	.00	1	148
B	EJ 2420Z2 Ring 8"	9000100000713	.71	1	149
C	48x2.5 24 Ecc Cone PHS S	204809V2100000025	2.50	1	2,370
D	48x4.0 BBL PHS S	204801V0100000040	4.00	1	3,480
E	48x4.0 BBL FB PHS S	204801V5100000040	4.00	1	3,480
F	Unknown		.00	1	0
Total Weight (lbs)					9,627

Misc. Items	
Description	Qty
Gasket PHS 48 inch SSMH	2
Joint Seal CS102 1X14.5	1

Production Use	
Mfg. Date:	
Ship Date:	
Frame/Ring:	
Grate/Cover:	
PREPOUR:	
POSTPOUR:	