

# PARKER & PINE RETAIL PINE LANE AND S. PARKER ROAD LANDSCAPE AND IRRIGATION CONSTRUCTION DOCUMENTS

LOT 1 BLOCK 3 PARKER AUTO PLAZA FILING NO.1  
A PART OF THE SOUTHEAST QUARTER OF SECTION 9 AND A PART OF THE  
NORTHEAST QUARTER OF SECTION 16 TOWNSHIP 6 SOUTH, RANGE 66 WEST OF THE  
6TH P.M. TOWN OF PARKER, COUNTY OF DOUGLAS, STATE OF COLORADO

**CONTACTS:**

**DEVELOPER:**  
EISENBERG COMPANY, INC.  
2710 E. CAMELBACK ROAD, SUITE 210  
PHOENIX, AZ 85016  
TEL: (602) 468-6100  
CONTACT: RYAN AMATO

**ENGINEER:**  
KIMLEY-HORN AND ASSOCIATES, INC.  
4582 SOUTH ULSTER STREET, SUITE 1500  
DENVER, CO 80237  
TEL: (303) 228-2318  
CONTACT: DAN SKEEHAN

**LANDSCAPE ARCHITECT:**  
KIMLEY-HORN AND ASSOCIATES, INC.  
4582 SOUTH ULSTER STREET, SUITE 1500  
DENVER, CO 80237  
TEL: (303) 228-2319  
CONTACT: CHRIS HEPLER

**TELEPHONE:**  
CENTURYLINK  
1801 CALIFORNIA STREET, SUITE 240  
DENVER, CO 80202  
CONTACT: IZZY MILLER  
EMAIL: IZZY.MILLER@CENTURYLINK.COM

**GAS SERVICE:**  
XCEL ENERGY  
1800 LARIMER STREET  
DENVER, CO 80202  
CONTACT: RON JOHNSON  
EMAIL: RON.H.JOHNSON@XCELENERGY.COM

**TOWN OF PARKER:**  
TOWN OF PARKER  
20120 EAST MAINSTREET  
PARKER, CO 80138-7334  
TEL: (303) 805-3331  
CONTACT: CAROLYN PARKINSON

**ELECTRICAL SERVICE:**  
IREA  
5496 US HWY 85  
SEDALIA, CO 80135  
TEL: (303) 688-7431  
CONTACT: AMANDA STEINER

**ARCHITECT:**  
NAOS DESIGN GROUP, LLC  
4949 SOUTH SYRACUSE ST. SUITE 460  
DENVER, CO 80237  
TEL: 303-759-5777  
CONTACT: JORDAN BONICELLI

**SURVEYOR:**  
ENGINEERING SERVICE COMPANY  
1300 SOUTH POTOMAC ST. SUITE 126  
AURORA, CO 80012  
TEL: 303-337-1393  
CONTACT: CHARLES BECKSTROM, PLS

**TELEVISION:**  
COMCAST  
1601 MILE HIGH STADIUM CIRCLE  
DENVER, CO 80204  
CONTACT: DEAN FLENTHROP  
EMAIL: DEAN\_FLENTHROP@CABLE.COMCAST.COM

**WATER/SANITARY SEWER:**  
PARKER WATER AND SANITATION DISTRICT  
18100 E. WOODMAN ROAD  
PARKER, CO 80134  
TEL: 303-841-4627  
CONTACT: DRAYTON SANDERSON

**FIRE DEPARTMENT:**  
SOUTH METRO FIRE RESCUE AUTHORITY  
9195 E. MINERAL AVE.  
CENTENNIAL, CO 80112  
TEL: (720) 989-2244  
CONTACT: CHIP KERKHOVE

**TOWN OF PARKER PLAN REVIEW:**  
20120 E. MAINSTREET  
PARKER, CO 80138  
TEL: (303) 805-3169  
CONTACT: RANDY CAPRA



**VICINITY MAP**  
1" = 2,000'

Sheet Number	Sheet Title
L1.0	COVER SHEET
L1.1	LANDSCAPE PLAN
L1.2	LANDSCAPE PLAN
L1.3	LANDSCAPE PLAN
L1.4	LANDSCAPE PLAN
L1.5	LANDSCAPE NOTES AND SCHEDULE
L1.6	LANDSCAPE DETAILS
IR1.1	IRRIGATION PLAN
IR1.2	IRRIGATION PLAN
IR1.3	IRRIGATION PLAN
IR1.4	IRRIGATION PLAN
IR1.5	IRRIGATION DETAILS
IR1.6	IRRIGATION DETAILS

**LEGAL DESCRIPTION**

PARKER AUTO PLAZA FILING NO. 1 - LOT 1, BLOCK 3 COUNTY OF DOUGLAS, STATE OF COLORADO.

**BENCHMARK**

DOUGLAS CONTROL MONUMENT #1.095035, A 3 1/4" ALUMINUM CAP.

ELEVATION = 5906.34 FEET (NAVD 1988), AS PUBLISHED BY DOUGLAS COUNTY.

**BASIS OF BEARINGS**

BEARINGS SHOWN HEREON ARE BASED UPON THE WEST LINE OF THE SW 1/4 OF SECTION 10, TOWNSHIP 6 SOUTH, RANGE 66 WEST, OF THE 6TH PRINCIPAL MERIDIAN BEARING S00°17'51"W AS REFERENCED ON THE PLAT OF PARKER AUTO PLAZA FILING NO.1 AND BOUND BY THE MONUMENTS SHOWN HEREON.

EXHIBIT F

Parker Water & Sanitation District (PWS D)  
Landscape/Irrigation Worksheet

Project Name: PARKER AND PINE updated 9/24/07

Landscape/Irrigation Tap address (physical location of tap) PARKER AND PINE

Landscape Area	High Water TURF (6,000sf = 1 SFE)	Low Water Native Grass and Spray Shrubs & Perennials (10,000sf = 1 SFE)	Drip Irrigated area (20,000sf = 1 SFE)	Sub-Total of Non-Irrigated area (calculated) Areas	PWS D one SFE per 6000	SFE Requirement (Sub-Total Calculation divided by 6000 = requirement)	
	Area #1	16,675 sf x 1 = 16,675	0 sf x .6 = 0	18,075 sf x .3 = 5,422	445,600 sf x 0 = 0	22,097 sf	6,000

Worksheet Completed by: Chris Hepler      Owner/Developer: Eisenberg Company  
 Company: Kimley-Horn      Attn: Ryan Amato  
 Address: 4582 S Ulster St. Suite 1500, Denver 80237      Billing Address: 2710 E Camelback Rd. Suite 210, Phoenix, AZ 85016  
 Phone #: 303-228-2300      Phone #: 602-468-6100

**ET Controller (with Rain Sensor)**

Manufacturer: <u>Hunter</u>	Tap Size Requirements: 0 - 1 SFE's requires a 3/4-inch tap 1.1 - 2.0 SFE's requires a 1-inch tap 2.1 - 4.0 SFE's requires a 1 1/2-inch tap 4.1 - 8.0 SFE's requires a 2-inch tap 8.1 - 16.0 SFE's requires a 3-inch tap
Model number: <u>IC-3600-PED-SS</u>	

NO.	REVISION	BY	DATE	APPR

**Kimley»Horn**  
2019 KIMLEY-HORN AND ASSOCIATES, INC.  
4582 South Ulster Street, Suite 1500  
Denver, Colorado 80237 (303) 228-2300

DESIGNED BY: DLS  
DRAWN BY: ECZ  
CHECKED BY: DLS  
DATE: 11/14/19

**PARKER & PINE  
PARKER, CO  
CONSTRUCTION DOCUMENTS  
COVER SHEET**

**PRELIMINARY**  
FOR REVIEW ONLY  
NOT FOR  
CONSTRUCTION  
**Kimley»Horn**  
Kimley-Horn and Associates, Inc.

PROJECT NO.  
096502001  
DRAWING NAME  
096502001R-CV  
**L1.0**



k:\den\_civil\096502001 - mixed use parker rd\CADD\plansheets\096502001R-CV.dwg Hepler, Christopher 10/8/2019 10:57 AM









**GENERAL LANDSCAPE SPECIFICATIONS**

- A. SCOPE OF WORK**
1. THE WORK CONSISTS OF: FURNISHING ALL LABOR, MATERIALS, EQUIPMENT, TOOLS, TRANSPORTATION, AND ANY OTHER APPURTENANCES NECESSARY FOR THE COMPLETION OF THIS PROJECT AS SHOWN ON THE DRAWINGS AND AS SPECIFIED HEREIN.
  2. WORK SHALL INCLUDE MAINTENANCE AND WATERING OF ALL CONTRACT PLANTING AREAS UNTIL CERTIFICATION OF ACCEPTANCE BY THE OWNER.
- B. PROTECTION OF EXISTING STRUCTURES**
1. ALL EXISTING BUILDINGS, WALKS, WALLS, PAVING, PIPING, OTHER SITE CONSTRUCTION ITEMS, AND PLANTING ALREADY COMPLETED OR ESTABLISHED AND DESIGNATED TO REMAIN SHALL BE PROTECTED FROM DAMAGE BY THE CONTRACTOR UNLESS OTHERWISE SPECIFIED. ALL DAMAGE RESULTING FROM NEGLIGENCE SHALL BE REPAIRED OR REPLACED TO THE SATISFACTION OF THE OWNER, AT NO COST TO THE OWNER.
  2. THE CONTRACTOR SHALL BE RESPONSIBLE FOR MAINTAINING ALL NECESSARY BEST MANAGEMENT PRACTICES (BMP) DEVICES ACCORDING TO ALL REGULATORY AGENCY'S STANDARDS THROUGH THE DURATION OF ALL CONSTRUCTION ACTIVITIES.
  3. THE CONTRACTOR SHALL BE RESPONSIBLE FOR ANY MAINTENANCE OF TRAFFIC (MOT) THAT MAY BE REQUIRED FOR THE PROJECT.
  4. THE CONTRACTOR SHALL BE RESPONSIBLE FOR LOCATING ALL UTILITIES, WHETHER PUBLIC OR PRIVATE, PRIOR TO EXCAVATION. THE OWNER AND DESIGN PROFESSIONAL SHALL NOT BE RESPONSIBLE FOR THE ACCURACY AND COMPLETENESS OF ANY SUCH INFORMATION OR DATA. THE CONTRACTOR SHALL HAVE FULL RESPONSIBILITY FOR REVIEWING AND CHECKING ALL SUCH INFORMATION AND DATA, LOCATING ALL UNDERGROUND FACILITIES DURING CONSTRUCTION, THE SAFETY AND PROTECTION THEREOF, REPAIRING ANY DAMAGE THERETO RESULTING FROM THE WORK. THE COST OF ALL WILL BE CONSIDERED AS HAVING BEEN INCLUDED IN THE CONTRACT PRICE. THE CONTRACTOR SHALL NOTIFY ANY AFFECTED UTILITY COMPANIES OR AGENCIES IN WRITING AT LEAST 48 HOURS PRIOR TO BEGINNING CONSTRUCTION.
- C. PROTECTION OF EXISTING PLANT MATERIALS**
1. THE CONTRACTOR SHALL BE RESPONSIBLE FOR ALL UNAUTHORIZED CUTTING OR DAMAGE TO TREES AND SHRUBS EXISTING OR OTHERWISE, CAUSED BY CARELESS EQUIPMENT OPERATION, MATERIAL STOCKPILING, ETC., THIS SHALL INCLUDE COMPACTION BY DRIVING OR PARKING INSIDE THE DRIP-LINE AND SPILLING OIL, GASOLINE, OR OTHER DEleterious MATERIALS WITHIN THE DRIP-LINE. NO MATERIALS SHALL BE BURNED ON SITE. EXISTING TREES KILLED OR DAMAGED SO THAT THEY ARE MISSHAPEN AND/OR UNSIGHTLY SHALL BE REPLACED AT THE COST TO THE CONTRACTOR OF FOUR HUNDRED DOLLARS (\$400) PER CALIPER INCH ON AN ESCALATING SCALE WHICH ADDS AN ADDITIONAL TWENTY (20) PERCENT PER INCH OVER FOUR (4) INCHES CALIPER AS FIXED AND AGREED. DAMAGE TO TREES SHALL BE MEASURED SIX (6) INCHES ABOVE GROUND LEVEL FOR TREES UP TO AND INCLUDING FOUR (4) INCHES IN CALIPER AND TWELVE (12) INCHES ABOVE GROUND LEVEL FOR TREES OVER FOUR (4) INCHES IN CALIPER.
  2. SEE TREE MITIGATION PLAN AND NOTES, IF APPLICABLE.
- D. MATERIALS**
1. GENERAL  
MATERIAL SAMPLES BELOW SHALL BE SUBMITTED FOR APPROVAL, ON SITE OR AS DETERMINED BY THE OWNER. UPON APPROVAL, DELIVERY OF MATERIALS MAY COMMENCE.  

MATERIAL	SAMPLE SIZE
MULCH	ONE (1) CUBIC FOOT
TOPSOIL MIX	ONE (1) CUBIC FOOT
PLANTS	ONE (1) OF EACH VARIETY (OR TAGGED IN NURSERY)
  2. PLANT MATERIALS  
    - a. PLANT SPECIES AND SIZE SHALL CONFORM TO THOSE INDICATED ON THE DRAWINGS. ALL PLANT MATERIAL SHALL MEET OR EXCEED CURRENT AMERICAN STANDARD FOR NURSERY STOCK ANSI Z60.1 AND THE COLORADO NURSERY ACT AND ACCOMPANYING RULES AND REGULATIONS. ALL PLANTS SHALL BE HEALTHY, VIGOROUS, SOUND, WELL-BRANCHED, AND FREE OF DISEASE AND INSECTS, INSECT EGGS AND LARVAE AND SHALL HAVE ADEQUATE ROOT SYSTEMS.
    - b. TREES FOR PLANTING IN ROWS SHALL BE UNIFORM IN SIZE AND SHAPE. ALL MATERIALS SHALL BE SUBJECT TO APPROVAL BY THE OWNER. WHERE ANY REQUIREMENTS ARE OMITTED FROM THE PLANT LIST, THE PLANTS FURNISHED SHALL BE NORMAL FOR THE VARIETY.
    - c. PLANTS SHALL BE PRUNED PRIOR TO DELIVERY ONLY WITH APPROVAL FROM PROJECT LANDSCAPE ARCHITECT.
    - d. NO SUBSTITUTIONS SHALL BE MADE WITHOUT WRITTEN PERMISSION FROM THE PROJECT LANDSCAPE ARCHITECT.
    - e. THE HEIGHT AND/OR WIDTH OF TREES SHALL BE MEASURED FROM THE GROUND OR ACROSS THE NORMAL SPREAD OF BRANCHES WITH THE PLANTS IN THEIR NORMAL POSITION. THIS MEASUREMENT SHALL NOT INCLUDE THE IMMEDIATE TERMINAL GROWTH. PLANTS LARGER IN SIZE THAN THOSE SPECIFIED IN THE PLANT LIST MAY BE USED IF APPROVED BY THE OWNER. IF THE USE OF LARGER PLANTS IS APPROVED, THE BALL OF EARTH OR SPREAD OF ROOTS SHALL BE INCREASED IN PROPORTION TO THE SIZE OF THE PLANT.
    - f. PLANTS SHALL BE SUBJECT TO INSPECTION AND APPROVAL AT THE PLACE OF GROWTH, OR UPON DELIVERY TO THE SITE, AS DETERMINED BY THE OWNER, FOR QUALITY, SIZE, AND VARIETY. SUCH APPROVAL SHALL NOT IMPAIR THE RIGHT OF INSPECTION AND REJECTION AT THE SITE DURING PROGRESS OF THE WORK OR AFTER COMPLETION FOR SIZE AND CONDITION OF ROOT BALLS OR ROOTS, LATENT DEFECTS OR INJURIES. REJECTED PLANTS SHALL BE REMOVED IMMEDIATELY FROM THE SITE. NOTICE REQUESTING INSPECTION SHALL BE SUBMITTED IN WRITING BY THE CONTRACTOR AT LEAST ONE (1) WEEK PRIOR TO ANTICIPATED DATE.
- E. SOIL MIXTURE**
1. CONTRACTOR SHALL TEST EXISTING SOIL AND AMEND AS NECESSARY IN ACCORDANCE WITH THE GUIDELINES BELOW:
  2. SOIL MIXTURE SHALL CONSIST OF TWO PARTS OF TOPSOIL AND ONE PART SAND, AS DESCRIBED BELOW. CONTRACTOR TO SUBMIT SAMPLES AND PH TESTING RESULTS OF SOIL MIXTURE FOR OWNER'S REPRESENTATIVE APPROVAL PRIOR TO PLANT INSTALLATION OPERATIONS COMMENCE.  
    - a. TOPSOIL FOR USE IN PREPARING SOIL MIXTURE FOR BACKFILLING PLANT OPENINGS SHALL BE FERTILE, FRIABLE, AND OF A LOAMY CHARACTER; REASONABLY FREE OF SUBSOIL, CLAY LUMPS, BRUSH WEEDS AND OTHER LITTER; FREE OF ROOTS, STUMPS, STONES LARGER THAN 2" IN ANY DIRECTION, AND OTHER EXTRANEIOUS OR TOXIC MATERIALS HARMFUL TO PLANT GROWTH. IT SHALL CONTAIN THREE (3) TO FIVE (5) PERCENT DECOMPOSED ORGANIC MATTER AND HAVE A PH BETWEEN 5.5 AND 7.5. SUBMIT SOIL SAMPLE AND PH TESTING RESULTS FOR APPROVAL.
    - b. SAND SHALL BE COARSE, CLEAN, WELL-DRAINING, NATIVE SAND.
  3. TREES SHALL BE PLANTED IN THE EXISTING NATIVE SOIL ON SITE, UNLESS DETERMINED TO BE UNSUITABLE - AT WHICH POINT THE CONTRACTOR SHALL CONTACT THE PROJECT LANDSCAPE ARCHITECT TO DISCUSS ALTERNATE RECOMMENDATION PRIOR TO PLANTING.
- F. WATER**
1. WATER NECESSARY FOR PLANTING AND MAINTENANCE SHALL BE OF SATISFACTORY QUALITY TO SUSTAIN ADEQUATE PLANT GROWTH AND SHALL NOT CONTAIN HARMFUL, NATURAL OR MAN-MADE ELEMENTS DETRIMENTAL TO PLANTS. WATER MEETING THE ABOVE STANDARD SHALL BE OBTAINED ON THE SITE FROM THE OWNER, IF AVAILABLE, AND THE CONTRACTOR SHALL BE RESPONSIBLE TO MAKE ARRANGEMENTS FOR ITS USE BY HIS TANKS, HOSES, SPRINKLERS, ETC.... IF SUCH WATER IS NOT AVAILABLE AT THE SITE, THE CONTRACTOR SHALL PROVIDE SATISFACTORY WATER FROM SOURCES OFF THE SITE AT NO ADDITIONAL COST TO THE OWNER.  
 \* WATERING/IRRIGATION RESTRICTIONS MAY APPLY - REFER TO PROPERTY'S JURISDICTIONAL AUTHORITY.
- G. FERTILIZER**
1. CONTRACTOR SHALL PROVIDE FERTILIZER APPLICATION SCHEDULE TO OWNER, AS APPLICABLE TO SOIL TYPE, PLANT INSTALLATION TYPE, AND SITE'S PROPOSED USE. SUGGESTED FERTILIZER TYPES SHALL BE ORGANIC OR OTHERWISE NATURALLY-DERIVED.  
 \* FERTILIZER RESTRICTIONS MAY APPLY - REFER TO PROPERTY'S JURISDICTIONAL AUTHORITY.
- H. MULCH**
1. MULCH MATERIAL SHALL BE MOISTENED AT THE TIME OF APPLICATION TO PREVENT WIND DISPLACEMENT, AND APPLIED AT A DEPTH OF THREE (3) INCHES CLEAR MULCH FROM EACH PLANTS CROWN (BASE) OR AS SHOWN IN PLANTING DETAILS. MULCH SHALL BE DOUBLE SHREDDED HARDWOOD MULCH. DYED MULCH IS NOT ACCEPTABLE. SUBMIT SAMPLES TO PROJECT LANDSCAPE ARCHITECT FOR APPROVAL.
  2. MULCH SHALL BE PROVIDED OVER THE ENTIRE AREA OF EACH SHRUB BED, GROUND COVER, VINE BED, AND TREE RING (Ø MINIMUM) PLANTED UNDER THIS CONTRACT, AS WELL AS FOR ANY EXISTING LANDSCAPE AREAS AS SHOWN ON PLANS.
- I. DIGGING AND HANDLING**
1. ALL TREES SPECIFIED SHALL BE BALLED AND BURLAPPED (B&B) UNLESS OTHERWISE APPROVED BY PROJECT LANDSCAPE ARCHITECT.
  2. PROTECT ROOTS OR ROOT BALLS OF PLANTS AT ALL TIMES FROM SUN, DRYING WINDS, WATER AND FREEZING, AS NECESSARY UNTIL PLANTING. PLANT MATERIALS SHALL BE ADEQUATELY PACKED TO PREVENT DAMAGE DURING TRANSPORT. TREES TRANSPORTED MORE THAN TEN (10) MILES OR WHICH ARE NOT PLANTED WITHIN THREE (3) DAYS OF DELIVERY TO THE SITE SHALL BE SPRAYED WITH AN ANTITRANSPIRANT PRODUCT ("WILTFRUP" OR EQUAL) TO MINIMIZE TRANSPIRATIONAL WATER LOSS.

3. B&B AND FIELD GROWN (FG) PLANTS SHALL BE DUG WITH FIRM, NATURAL BALLS OF SOIL OF SUFFICIENT SIZE TO ENCOMPASS THE FIBROUS AND FEEDING ROOTS OF THE PLANTS. NO PLANTS MOVED WITH A ROOT BALL SHALL BE PLANTED IF THE BALL IS CRACKED OR BROKEN. PLANTS SHALL NOT BE HANDLED BY STEMS.
- J. CONTAINER GROWN STOCK**
1. ALL CONTAINER GROWN MATERIAL SHALL BE HEALTHY, VIGOROUS, WELL-ROOTED PLANTS ESTABLISHED IN THE CONTAINER IN WHICH THEY ARE SOLD. THE PLANTS SHALL HAVE TOPS WHICH ARE OF GOOD QUALITY AND ARE IN A HEALTHY GROWING CONDITION.
  2. AN ESTABLISHED CONTAINER GROWN PLANT SHALL BE TRANSPLANTED INTO A CONTAINER AND GROWN IN THAT CONTAINER SUFFICIENTLY LONG ENOUGH FOR THE NEW FIBROUS ROOTS TO HAVE DEVELOPED SO THAT THE ROOT MASS WILL RETAIN ITS SHAPE AND HOLD TOGETHER WHEN REMOVED FROM THE CONTAINER. CONTAINER GROWN STOCK SHALL NOT BE HANDLED BY THEIR STEMS.
  3. ROOT BOUND PLANTS ARE NOT ACCEPTABLE AND WILL BE REJECTED.
- K. MATERIALS LIST**
1. QUANTITIES NECESSARY TO COMPLETE THE WORK ON THE DRAWINGS SHALL BE FURNISHED BY THE CONTRACTOR. QUANTITY ESTIMATES HAVE BEEN MADE CAREFULLY, BUT THE LANDSCAPE ARCHITECT OR OWNER ASSUMES NO LIABILITY FOR OMISSIONS OR ERRORS. SHOULD A DISCREPANCY OCCUR BETWEEN THE PLANS AND THE PLANT LIST QUANTITY, THE PLANS SHALL GOVERN. ALL DIMENSIONS AND/OR SIZES SPECIFIED SHALL BE THE MINIMUM ACCEPTABLE SIZE.
- L. FINE GRADING**
1. FINE GRADING UNDER THIS CONTRACT SHALL CONSIST OF FINAL FINISHED GRADING OF LAWN AND PLANTING AREAS THAT HAVE BEEN DISTURBED DURING CONSTRUCTION.
  2. THE CONTRACTOR SHALL FINE GRADE THE LAWN AND PLANTING AREAS TO BRING THE ROUGH GRADE UP TO FINAL FINISHED GRADE ALLOWING FOR THICKNESS OF SOD AND/OR MULCH DEPTH.
  3. ALL PLANTING AREAS SHALL BE GRADED AND MAINTAINED FOR POSITIVE DRAINAGE TO SURFACE/SUBSURFACE STORM DRAIN SYSTEMS. AREAS ADJACENT TO BUILDINGS SHALL SLOPE AWAY FROM THE BUILDINGS. REFER TO CIVIL ENGINEER'S PLANS FOR FINAL GRADES, IF APPLICABLE.
- M. PLANTING PROCEDURES**
1. THE CONTRACTOR SHALL CLEAN WORK AND SURROUNDING AREAS OF ALL RUBBISH OR OBJECTIONABLE MATTER DAILY. ALL MORTAR, CEMENT, BUILDING MATERIALS, AND TOXIC MATERIAL SHALL BE COMPLETELY REMOVED FROM PLANTING AREAS. THESE MATERIALS SHALL NOT BE MIXED WITH THE SOIL. SHOULD THE CONTRACTOR FIND SUCH SOIL CONDITIONS IN PLANTING AREAS WHICH WILL ADVERSELY AFFECT THE PLANT GROWTH, THE CONTRACTOR SHALL IMMEDIATELY CALL IT TO THE ATTENTION OF THE OWNER'S REPRESENTATIVE. FAILURE TO DO SO BEFORE PLANTING SHALL MAKE THE CORRECTIVE MEASURES THE RESPONSIBILITY OF THE CONTRACTOR.
  2. VERIFY LOCATIONS OF ALL UTILITIES, CONDUITS, SUPPLY LINES AND CABLES, INCLUDING BUT NOT LIMITED TO: ELECTRIC, GAS (LINES AND TANKS), WATER, SANITARY SEWER, STORMWATER SYSTEMS, CABLE, AND TELEPHONE. PROPERLY MAINTAIN AND PROTECT EXISTING UTILITIES. CALL COLORADO (811) TO LOCATE UTILITIES AT LEAST 48 HOURS PRIOR TO CONSTRUCTION.
  3. CONTRACTOR IS RESPONSIBLE TO REMOVE ALL EXISTING AND IMPORTED LIMEROCK AND LIMEROCK SUB-BASE FROM ALL PLANTING AREAS TO A MINIMUM DEPTH OF 36" OR TO NATIVE SOIL. CONTRACTOR IS RESPONSIBLE TO BACKFILL THESE PLANTING AREAS TO ROUGH FINISHED GRADE WITH CLEAN TOPSOIL FROM AN ON-SITE SOURCE OR AN IMPORTED SOURCE. IF LIMEROCK OR OTHER ADVERSE CONDITIONS OCCUR IN PLANTED AREAS AFTER 36" DEEP EXCAVATION BY THE CONTRACTOR, AND POSITIVE DRAINAGE CAN NOT BE ACHIEVED, CONTRACTOR SHALL UTILIZE POOR DRAINAGE CONDITION PLANTING DETAIL.
  4. FURNISH NURSERY'S CERTIFICATE OF COMPLIANCE WITH ALL REQUIREMENTS AS SPECIFIED HEREIN. INSPECT AND SELECT PLANT MATERIALS BEFORE PLANTS ARE DUG AT NURSERY OR GROWING SITE.
  5. COMPLY WITH APPLICABLE FEDERAL, STATE, COUNTY, AND LOCAL REGULATIONS GOVERNING LANDSCAPE MATERIALS AND WORK UPON ARRIVAL AT THE SITE. PLANTS SHALL BE THOROUGHLY WATERED AND PROPERLY MAINTAINED UNTIL PLANTED. PLANTS STORED ONSITE SHALL NOT REMAIN UNPLANTED OR APPROPRIATELY HEALED IN FOR A PERIOD EXCEEDING TWENTY-FOUR (24) HOURS. AT ALL TIMES WORKMANLIKE METHODS CUSTOMARY IN ACCEPTED HORTICULTURAL PRACTICES AS USED IN THE TRADE SHALL BE EXERCISED.
  6. WORK SHALL BE COORDINATED WITH OTHER TRADES TO PREVENT CONFLICTS. COORDINATE PLANTING WITH IRRIGATION WORK TO ASSURE AVAILABILITY OF WATER AND PROPER LOCATION OF IRRIGATION APPURTENANCES AND PLANTS.
  7. PRIOR TO EXCAVATION OF TREE OPENINGS, AN AREA EQUAL TO TWO TIMES THE DIAMETER OF THE ROOT BALL SHALL BE ROTO-TILLED TO A DEPTH EQUAL TO THE DEPTH OF THE ROOT BALL.
  8. EXCAVATION OF TREE OPENINGS SHALL BE PERFORMED USING EXTREME CARE TO AVOID DAMAGE TO SURFACE AND SUBSURFACE ELEMENTS SUCH AS UTILITIES OR HARDSCAPE ELEMENTS, FOOTERS AND PREPARED SUB-BASES.
  9. IN CONTINUOUS SHRUB AND GROUND COVER BEDS, THE ROTO-TILLED PERIMETER SHOULD EXTEND TO A DISTANCE OF ONE FOOT BEYOND THE DIAMETER OF A SINGLE ROOT BALL. THE BED SHALL BE TILLED TO A DEPTH EQUAL TO THE ROOT BALL DEPTH PLUS 6".
  10. TREE OPENINGS FOR WELL DRAINED SOILS SHALL BE DUG SO THAT THE BOTTOM OF THE ROOT BALL WILL REST ON UNDISTURBED SOIL AND THE TOP OF THE ROOT BALL WILL BE FLUSH WITH FINISH GRADE. IN POORLY DRAINED SOILS THE TREE OPENING SHALL BE DUG SO THAT THE ROOT BALL RESTS ON UNDISTURBED SOIL AND THE TOP OF THE ROOT BALL IS 1" ABOVE FINISH GRADE. PLANT PIT WALLS SHALL BE SCARIFIED PRIOR TO PLANT INSTALLATION.
  11. TAKE ALL NECESSARY PRECAUTIONS TO AVOID DAMAGE TO BUILDINGS AND BUILDING STRUCTURES WHILE INSTALLING TREES.
  12. SOIL MIXTURE SHALL BE AS SPECIFIED IN SECTION 'E'.
  13. TREES AND SHRUBS SHALL BE SET STRAIGHT AT AN ELEVATION THAT, AFTER SETTLEMENT, THE PLANT CROWN WILL STAND ONE (1) TO TWO (2) INCHES ABOVE GRADE. EACH PLANT SHALL BE SET IN THE CENTER OF THE PIT. SOIL MIXTURE SHALL BE BACK FILLED, THOROUGHLY TAMPED AROUND THE BALL, AND SETTLED BY WATER (AFTER TAMPING).
  14. AMEND PINE AND OAK PLANT OPENINGS WITH ECTOMYCORRHIZAL SOIL APPLICATION PER MANUFACTURER'S RECOMMENDATION. ALL OTHER PLANT OPENINGS SHALL BE AMENDED WITH ENDOMYCORRHIZAL SOIL APPLICATION PER MANUFACTURER'S RECOMMENDATION. PROVIDE PRODUCT INFORMATION SUBMITTAL PRIOR TO INOCULATION.
  15. FILL HOLE WITH SOIL MIXTURE, MAKING CERTAIN ALL SOIL IS SATURATED. TO DO THIS, FILL HOLE WITH WATER AND ALLOW TO SOAK MINIMUM TWENTY (20) MINUTES, STIRRING IF NECESSARY TO GET SOIL THOROUGHLY WET. PACK LIGHTLY WITH FEET, ADD MORE WET SOIL MIXTURE. DO NOT COVER TOP OF BALL WITH SOIL MIXTURE.
  16. ALL BURLAP, ROPE, WIRES, BASKETS, ETC., SHALL BE REMOVED FROM THE SIDES AND TOPS OF BALLS, BUT NO BURLAP SHALL BE PULLED FROM UNDERNEATH.
  17. TREES SHALL BE PRUNED, IN ACCORDANCE WITH ANSI A-300, TO PRESERVE THE NATURAL CHARACTER OF THE PLANT. ALL SOFT WOOD OR SUCKER GROWTH AND ALL BROKEN OR BADLY DAMAGED BRANCHES SHALL BE REMOVED WITH A CLEAN CUT. ALL PRUNING TO BE PERFORMED BY CERTIFIED ARBORIST.
  18. SHRUBS AND GROUND COVER PLANTS SHALL BE EVENLY SPACED IN ACCORDANCE WITH THE DRAWINGS AND AS INDICATED ON THE PLANT LIST. MATERIALS INSTALLED SHALL MEET MINIMUM SPECIMEN REQUIREMENTS OR QUANTITIES SHOWN ON PLANS, WHICHEVER IS GREATER. CULTIVATE ALL PLANTING AREAS TO A MINIMUM DEPTH OF 6". REMOVE AND DISPOSE ALL DEBRIS. MIX TOP 4" THE PLANTING SOIL MIXTURE AS SPECIFIED IN SECTION E. THOROUGHLY WATER ALL PLANTS AFTER INSTALLATION.
  19. TREE GUYING AND BRACING SHALL BE INSTALLED BY THE CONTRACTOR IN ACCORDANCE WITH THE PLANS TO INSURE STABILITY AND MAINTAIN TREES IN AN UPRIGHT POSITION. IF THE CONTRACTOR AND OWNER DECIDE TO WAIVE THE TREE GUYING AND BRACING, THE OWNER SHALL NOTIFY THE PROJECT LANDSCAPE ARCHITECT IN WRITING AND AGREE TO INDEMNIFY AND HOLD HARMLESS THE PROJECT LANDSCAPE ARCHITECT IN THE EVENT UNSUPPORTED TREES PLANTED UNDER THIS CONTRACT FALL AND DAMAGE PERSON OR PROPERTY.
  20. ALL PLANT BEDS SHALL BE KEPT FREE OF NOXIOUS WEEDS UNTIL FINAL ACCEPTANCE OF WORK. IF DIRECTED BY THE OWNER, "ROUND-UP" SHALL BE APPLIED FOR WEED CONTROL BY QUALIFIED PERSONNEL TO ALL PLANTING AREAS IN SPOT APPLICATIONS PER MANUFACTURER'S RECOMMENDATIONS. PRIOR TO FINAL INSPECTION, TREAT ALL PLANTING BEDS WITH AN APPROVED PRE-EMERGENT HERBICIDE AT AN APPLICATION RATE RECOMMENDED BY THE MANUFACTURER. (AS ALLOWED BY JURISDICTIONAL AUTHORITY)
- N. LAWN SODDING**
1. THE WORK CONSISTS OF LAWN BED PREPARATION, SOIL PREPARATION, AND SODDING COMPLETE, IN STRICT ACCORDANCE WITH THE SPECIFICATIONS AND THE APPLICABLE DRAWINGS TO PRODUCE A TURF GRASS LAWN ACCEPTABLE TO THE OWNER.
  2. ALL AREAS THAT ARE TO BE SODDED SHALL BE CLEARED OF ANY ROUGH GRASS, WEEDS, AND DEBRIS BY MEANS OF A SOD CUTTER TO A DEPTH OF THREE (3) INCHES, AND THE GROUND BROUGHT TO AN EVEN GRADE. THE ENTIRE SURFACE SHALL BE ROLLED WITH A ROLLER WEIGHING NOT MORE THAN ONE-HUNDRED (100) POUNDS PER FOOT OF WIDTH. DURING THE ROLLING, ALL DEPRESSIONS CAUSED BY SETTLEMENT SHALL BE FILLED WITH ADDITIONAL SOIL, AND THE SURFACE SHALL BE REGRADED AND ROLLED UNTIL PRESENTING A SMOOTH AND EVEN FINISH TO THE REQUIRED GRADE.
  3. PREPARE LOOSE BED FOUR (4) INCHES DEEP. HAND RAKE UNTIL ALL BUMPS AND DEPRESSIONS ARE REMOVED. WET PREPARED AREA THOROUGHLY.
  4. SODDING  
    - a. THE CONTRACTOR SHALL SOD ALL AREAS THAT ARE NOT PAVED OR PLANTED AS DESIGNATED ON THE DRAWINGS WITHIN THE CONTRACT LIMITS, UNLESS SPECIFICALLY NOTED OTHERWISE.
    - b. SOD PANELS SHALL BE LAID TIGHTLY TOGETHER SO AS TO MAKE A SOLID SODDED LAWN AREA. SOD SHALL BE LAID

- UNIFORMLY AGAINST THE EDGES OF ALL CURBS AND OTHER HARDSCAPE ELEMENTS. PAVED AND PLANTED AREAS ADJACENT TO BUILDINGS. A 24 INCH STONE MULCH STRIP SHALL BE PROVIDED IMMEDIATELY FOLLOWING SOD LAYING. THE LAWN AREAS SHALL BE ROLLED WITH A LAWN ROLLER CUSTOMARILY USED FOR SUCH PURPOSES, AND THEN THOROUGHLY IRRIGATED. IF, IN THE OPINION OF THE OWNER, TOP-DRESSING IS NECESSARY AFTER ROLLING TO FILL THE VOIDS BETWEEN THE SOD PANELS AND TO EVEN OUT INCONSISTENCIES IN THE SOD, CLEAN SAND, AS APPROVED BY THE OWNER'S REPRESENTATIVE, SHALL BE UNIFORMLY SPREAD OVER THE ENTIRE SURFACE OF THE SOD AND THOROUGHLY WATERED IN. FERTILIZE INSTALLED SOD AS ALLOWED BY PROPERTY'S JURISDICTIONAL AUTHORITY.
5. DURING DELIVERY, PRIOR TO, AND DURING THE PLANTING OF THE LAWN AREAS, THE SOD PANELS SHALL AT ALL TIMES BE PROTECTED FROM EXCESSIVE DRYING AND UNNECESSARY EXPOSURE OF THE ROOTS TO THE SUN. ALL SOD SHALL BE STACKED SO AS NOT TO BE DAMAGED BY SWEATING OR EXCESSIVE HEAT AND MOISTURE.
- 6. LAWN MAINTENANCE**
- a. WITHIN THE CONTRACT LIMITS, THE CONTRACTOR SHALL PRODUCE A DENSE, WELL ESTABLISHED LAWN. THE CONTRACTOR SHALL BE RESPONSIBLE FOR THE REPAIR AND RE-SODDING OF ALL ERODED, SUNKEN OR BARE SPOTS (LARGER THAN 12"x12") UNTIL CERTIFICATION OF ACCEPTANCE BY THE OWNER'S REPRESENTATIVE. REPAIRED SODDING SHALL BE ACCOMPLISHED AS IN THE ORIGINAL WORK, INCLUDING REGRAIDING IF NECESSARY.
  - b. CONTRACTOR SHALL BE RESPONSIBLE FOR ESTABLISHING AND MAINTAINING SOD/LAWN UNTIL ACCEPTANCE BY THE OWNER'S REPRESENTATIVE. PRIOR TO AND UPON ACCEPTANCE, CONTRACTOR TO PROVIDE WATERING/IRRIGATION SCHEDULE TO OWNER. OBSERVE ALL APPLICABLE WATERING RESTRICTIONS AS SET FORTH BY THE PROPERTY'S JURISDICTIONAL AUTHORITY.
- O. CLEANUP**
1. UPON COMPLETION OF ALL PLANTING WORK AND BEFORE FINAL ACCEPTANCE, THE CONTRACTOR SHALL REMOVE ALL MATERIAL, EQUIPMENT, AND DEBRIS RESULTING FROM CONTRACTORS WORK. ALL PAVED AREAS SHALL BE CLEANED AND THE SITE LEFT IN A NEAT AND ACCEPTABLE CONDITION AS APPROVED BY THE OWNER'S REPRESENTATIVE.
- P. PLANT MATERIAL MAINTENANCE**
1. ALL PLANTS AND PLANTING INCLUDED UNDER THIS CONTRACT SHALL BE MAINTAINED BY WATERING, CULTIVATING, SPRAYING, PRUNING, AND ALL OTHER OPERATIONS (SUCH AS RE-STAKING OR REPAIRING GUY SUPPORTS) NECESSARY TO INSURE A HEALTHY PLANT CONDITION BY THE CONTRACTOR UNTIL CERTIFICATION OF ACCEPTANCE BY THE OWNER'S REPRESENTATIVE.
- Q. FINAL INSPECTION AND ACCEPTANCE OF WORK**
1. FINAL INSPECTION AT THE END OF THE WARRANTY PERIOD SHALL BE ON PLANTING, CONSTRUCTION AND ALL OTHER INCIDENTAL WORK PERTAINING TO THIS CONTRACT. ANY REPLACEMENT AT THIS TIME SHALL BE SUBJECT TO THE SAME ONE (1) YEAR WARRANTY (OR AS SPECIFIED BY THE LANDSCAPE ARCHITECT OR OWNER IN WRITING) BEGINNING WITH THE TIME OF REPLACEMENT AND ENDING WITH THE SAME INSPECTION AND ACCEPTANCE HEREIN DESCRIBED.
- R. WARRANTY**
1. THE LIFE AND SATISFACTORY CONDITION OF ALL PLANT MATERIAL INSTALLED (INCLUDING SOD) BY THE LANDSCAPE CONTRACTOR SHALL BE WARRANTED BY THE CONTRACTOR FOR A MINIMUM OF ONE (1) CALENDAR YEAR COMMENCING AT THE TIME OF CERTIFICATION OF ACCEPTANCE BY THE OWNER'S REPRESENTATIVE.
  2. ANY PLANT NOT FOUND IN A HEALTHY GROWING CONDITION AT THE END OF THE WARRANTY PERIOD SHALL BE REMOVED FROM THE SITE AND REPLACED AS SOON AS WEATHER CONDITIONS PERMIT. ALL REPLACEMENTS SHALL BE PLANTS OF THE SAME KIND AND SIZE AS SPECIFIED IN THE PLANT LIST. THEY SHALL BE FURNISHED PLANTED AND MULCHED AS SPECIFIED AT NO ADDITIONAL COST TO THE OWNER.
  3. IN THE EVENT THE OWNER DOES NOT CONTRACT WITH THE CONTRACTOR FOR LANDSCAPE AND IRRIGATION MAINTENANCE, THE CONTRACTOR SHOULD VISIT THE PROJECT SITE PERIODICALLY DURING THE ONE (1) YEAR WARRANTY PERIOD TO EVALUATE MAINTENANCE PROCEDURES BEING PERFORMED BY THE OWNER. CONTRACTOR SHALL NOTIFY THE OWNER IN WRITING OF MAINTENANCE PROCEDURES OR CONDITIONS WHICH THREATEN VIGOROUS AND HEALTHY PLANT GROWTH.

**PLANT SCHEDULE**

TREES	CODE	QTY	BOTANICAL NAME	COMMON NAME	CONT	CAL
	GP	23	GINKGO BILOBA 'PRINCETON SENTRY'	PRINCETON SENTRY GINKGO	B & B	2" CAL MN
	PA3	25	PYRUS CALLERYANA 'ARISTOCRAT' TM	ARISTOCRAT FLOWERING PEAR	B & B	2" CAL MN
	QR	9	QUERCUS ROBUR	ENGLISH OAK	B & B	2" CAL MN
	TG	43	TILIA CORDATA 'GREENSPIRE'	GREENSPIRE LITTLELEAF LINDEN	B & B	2" CAL MN
	UA	20	ULMUS X 'ACCOLADE'	ACCOLADE ELM	B & B	2" CAL MN

GROUND COVERS	CODE	QTY	BOTANICAL NAME	COMMON NAME	CONT	SIZE	SPACING
	KB	36,218 SF	KEN-TEX BLUEGRASS	KEN-TEX BLUEGRASS	SOD		
	SM2	670,177 SF	TOWN OF PARKER SEED MIX 3	TOWN OF PARKER SEED MIX 3	SEED		

L:\dev\cs\ill\096502001 - final\l15 - Parker - rd\096502001.lxd - Header - Chis - 10/16/10 10:47 AM  
 THIS DOCUMENT IS THE PROPERTY OF KIMLEY-HORN AND ASSOCIATES, INC. IT IS TO BE USED ONLY FOR THE PROJECT AND SITE SPECIFICALLY IDENTIFIED HEREIN. ALL INFORMATION CONTAINED HEREIN IS UNCLASSIFIED AND NOT FOR DISTRIBUTION OUTSIDE THE PROJECT AND SITE SPECIFICALLY IDENTIFIED HEREIN. ANY INSTRUMENT OF SERVICE OR AGREEMENT FOR SERVICE SHALL BE SUBJECT TO THE TERMS AND CONDITIONS OF SUCH INSTRUMENT. THE DOCUMENT, TOGETHER WITH THE CONCEPTS AND DESIGN PRESENTED HEREIN, SHALL BE WITHOUT LIABILITY TO KIMLEY-HORN AND ASSOCIATES, INC.

NO.	REVISION	BY	DATE

**Kimley»Horn**  
 2019 KIMLEY-HORN AND ASSOCIATES, INC.  
 4582 South Ulster Street, Suite 1500  
 Denver, Colorado 80237 (303) 228-2300

DESIGNED BY: NBB  
 DRAWN BY: NBB  
 CHECKED BY: CPH  
 DATE: 11/14/19

**PARKER & PINE**  
 PARKER, CO  
 CONSTRUCTION DOCUMENTS  
 LANDSCAPE NOTES AND SCHEDULE

**PRELIMINARY**  
 FOR REVIEW ONLY  
 NOT FOR  
 CONSTRUCTION  
**Kimley»Horn**  
 Kimley-Horn and Associates, Inc.  
 PROJECT NO.  
 096502001  
 DRAWING NAME  
 096502001LA  
**L1.5**

I:\den\civil\096502001 - mixed use parker\096502001A.dwg H:\den\civil\096502001 - mixed use parker\096502001A.dwg  
 10/19/2018 10:57 AM  
 THE INFORMATION CONTAINED HEREIN IS THE PROPERTY OF KIMLEY-HORN AND ASSOCIATES, INC. IT IS TO BE USED ONLY FOR THE PROJECT AND SITE SPECIFICALLY IDENTIFIED HEREIN. ANY REUSE OR MODIFICATION OF THIS INFORMATION WITHOUT THE WRITTEN AUTHORIZATION AND ADAPTATION BY KIMLEY-HORN AND ASSOCIATES, INC. SHALL BE WITHOUT LIABILITY TO KIMLEY-HORN AND ASSOCIATES, INC.

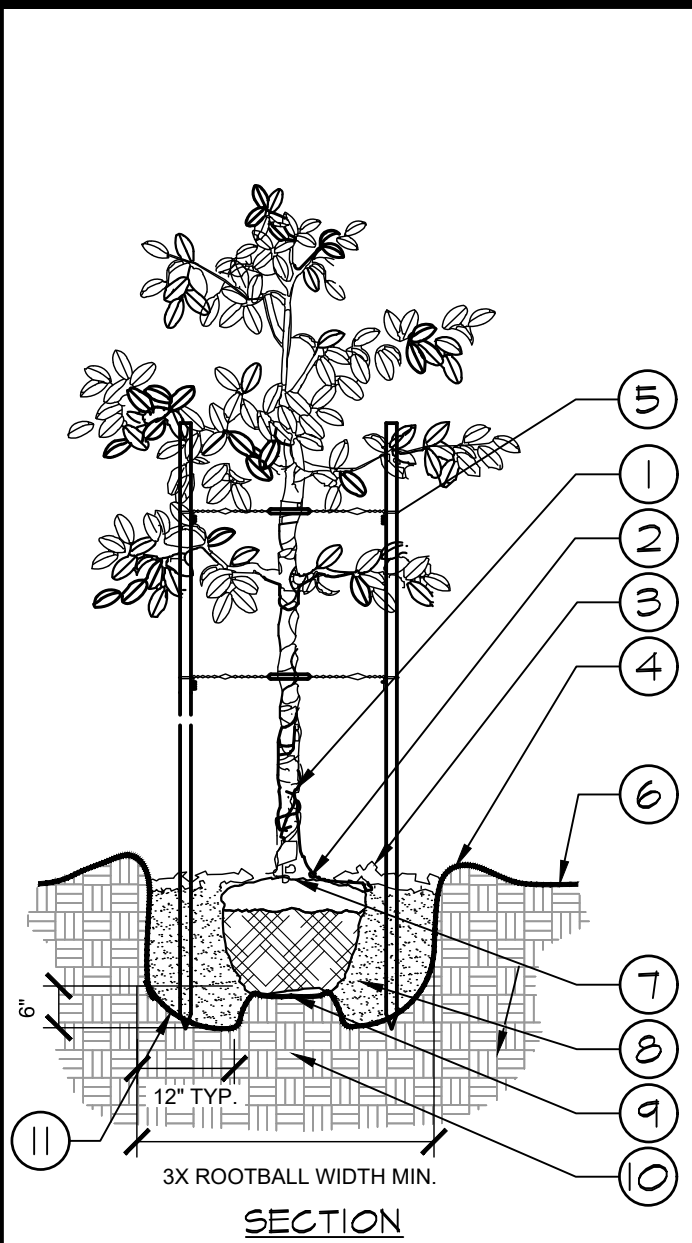

- 1 TRUNK/ROOT BALL TO BE CENTERED AND PLUMB/LEVEL IN PLANTING PIT.
  - 2 6" DIA. CLEAR OF MULCH AT TRUNK FLARE.
  - 3 3" MINIMUM MULCH AS SPECIFIED, WHERE TREES ARE PLACED IN SOIL. MULCH RING FOR TREES SHALL BE 6" DIAMETER (MIN.) OR AS DIRECTED BY OWNER'S REPRESENTATIVE.
  - 4 4" HIGH BERM, FIRMLY COMPACTED.
  - 5 8" x 2" TREATED LODGE POLE PINE TREE STAKES, TWO (2) PER TREE, AVOID PENETRATING ROOT BALL. 14 GAUGE, ANNEALED STEEL GUY WIRE, STAPLE ENDS TO INSIDE OF TREE STAKE. ADJUST TENSION BY TURNING WIRE PAIRS FROM THE MIDDLE.
  - 6 FINISHED GRADE. (SEE GRADING PLAN)
  - 7 TOP OF ROOTBALL MIN. 1" ABOVE FINISHED GRADE.
  - 8 PREPARED PLANTING SOIL AS SPECIFIED.
  - 9 TOP OF ROOTBALL SHALL BE 1" ABOVE FINISHED GRADE. ROOTBALLS GREATER THAN 24" DIAMETER SHALL BE PLACED ON MOUND OF UNDISTURBED SOIL TO PREVENT SETTLING. ROOTBALLS SMALLER THAN 24" IN DIAMETER MAY SIT ON COMPACTED EARTH.
  - 10 UNDISTURBED NATIVE SOIL.
  - 11 SCARIFY BOTTOM AND SIDES OF PLANTING PIT.
- NOTES:
- A. FINAL TREE STAKING DETAILS AND PLACEMENT TO BE APPROVED BY OWNER.
  - B. REMOVE BURLAP, WIRE AND STRAPS (ANYTHING THAT COULD GIRDLING TREE OR RESTRICT ROOT GROWTH) ON UPPER 1/3 OF ROOTBALL.
  - C. PRUNE ALL TREES IN ACCORDANCE WITH ANSI A-300.

1 TREE PLANTING  
SECTION / PLAN

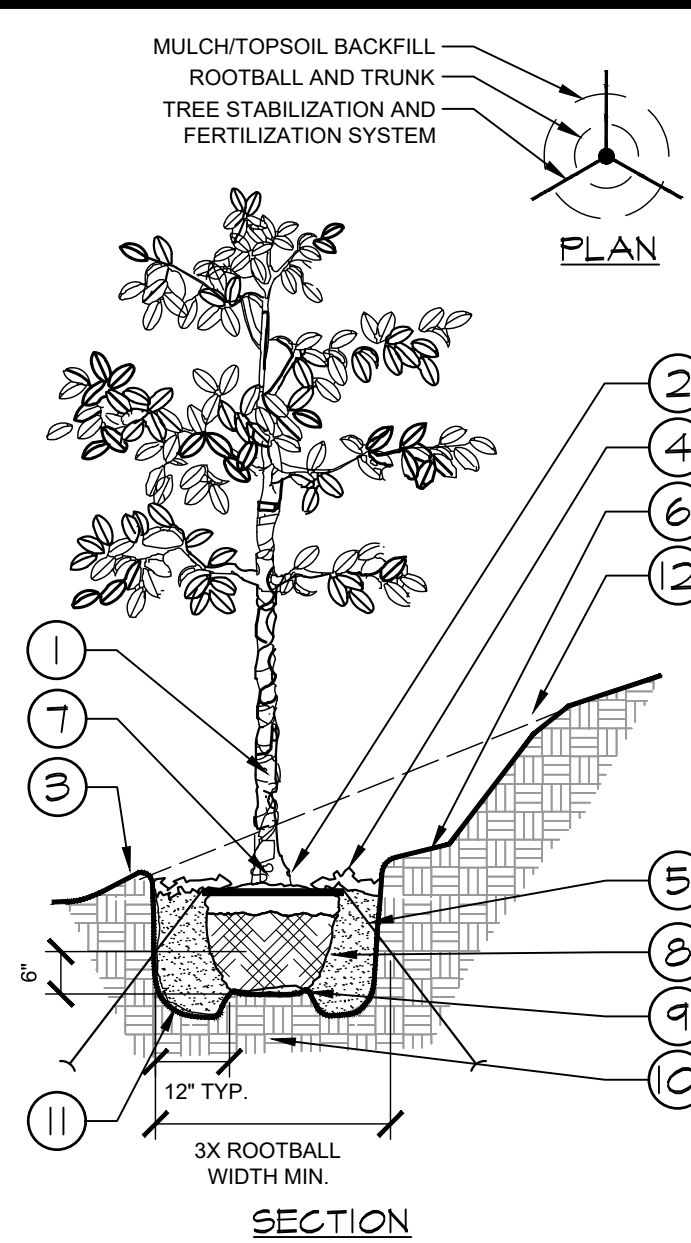

- 1 TRUNK/ROOT BALL TO BE CENTERED AND PLUMB/LEVEL IN PLANTING PIT.
  - 2 6" DIA. CLEAR OF MULCH AT TRUNK FLARE.
  - 3 4" HIGH BERM, FIRMLY COMPACTED.
  - 4 3" MINIMUM OF HARDWOOD BARK MULCH AS SPECIFIED, WHERE TREES ARE PLACED IN SOIL. MULCH RING FOR TREES SHALL BE 6" DIAMETER (MIN.) OR AS DIRECTED BY OWNER'S REPRESENTATIVE.
  - 5 TERRA TOGGLE EARTH ANCHOR SYSTEM INSTALLED PER MANUFACTURER'S RECOMMENDATIONS.
  - 6 4" MIN. OF TOPSOIL TO BRING TO FINISHED GRADE. (SEE GRADING PLAN)
  - 7 TOP OF ROOTBALL MIN. 1" ABOVE FINISHED GRADE.
  - 8 PREPARED PLANTING SOIL AS SPECIFIED.
  - 9 ROOTBALLS GREATER THAN 24" DIAMETER SHALL BE PLACED ON MOUND OF UNDISTURBED SOIL TO PREVENT SETTLING. ROOTBALLS SMALLER THAN 24" IN DIAMETER MAY SIT ON COMPACTED EARTH.
  - 10 UNDISTURBED NATIVE SOIL.
  - 11 SCARIFY BOTTOM AND SIDES OF PLANTING PIT.
  - 12 CUT BACK SLOPE TO PROVIDE A FLAT SURFACE FOR PLANTING.
- NOTES:
- A. FINAL TREE STAKING DETAILS AND PLACEMENT TO BE APPROVED BY OWNER.
  - B. REMOVE BURLAP, WIRE AND STRAPS (ANYTHING THAT COULD GIRDLING TREE OR RESTRICT ROOT GROWTH) ON UPPER 1/3 OF ROOTBALL.
  - C. PRUNE ALL TREES IN ACCORDANCE WITH ANSI A-300.

2 TREE PLANTING ON A SLOPE  
SECTION / PLAN

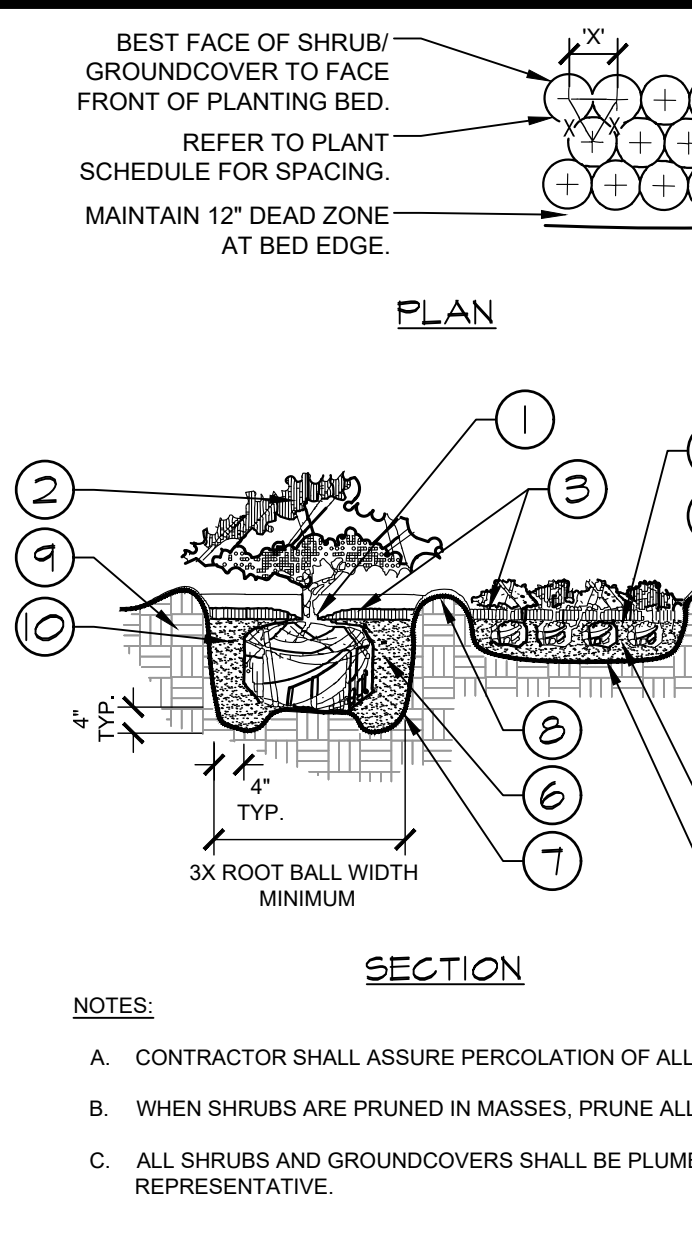

- 1 TOP OF SHRUB ROOTBALLS TO BE PLANTED 1" - 2" HIGH WITH SOIL MOUNDING UP TO THE TOP OF ROOTBALL.
  - 2 PRUNE ALL SHRUBS TO ACHIEVE A UNIFORM MASS/HEIGHT.
  - 3 3" MULCH LAYER AS SPECIFIED.
  - 4 EXCAVATE ENTIRE BED SPECIFIED FOR GROUNDCOVER BED.
  - 5 FINISHED GRADE (SEE GRADING PLAN).
  - 6 PREPARED PLANTING SOIL AS SPECIFIED. (SEE LANDSCAPE NOTES) NOTE: WHEN GROUND-COVERS AND SHRUBS USED IN MASSES, ENTIRE BED TO BE AMENDED WITH PLANTING SOIL MIX AS SPECIFIED.
  - 7 SCARIFY OF PLANTING PIT SIDES AND BOTTOM.
  - 8 4" HIGH BERM FIRMLY COMPACTED.
  - 9 UNDISTURBED NATIVE SOIL.
  - 10 FERTILIZER TABLETS (MAX 3" DEEP)
- NOTES:
- A. CONTRACTOR SHALL ASSURE PERCOLATION OF ALL PLANTING PITS PRIOR TO INSTALLATION.
  - B. WHEN SHRUBS ARE PRUNED IN MASSES, PRUNE ALL SHRUBS TO ACHIEVE UNIFORM MASS / HEIGHT.
  - C. ALL SHRUBS AND GROUNDCOVERS SHALL BE PLUMB VERTICALLY, UNLESS OTHERWISE DIRECTED BY OWNERS REPRESENTATIVE.

3 SHRUB/GROUNDCOVER PLANTING  
SECTION / PLAN

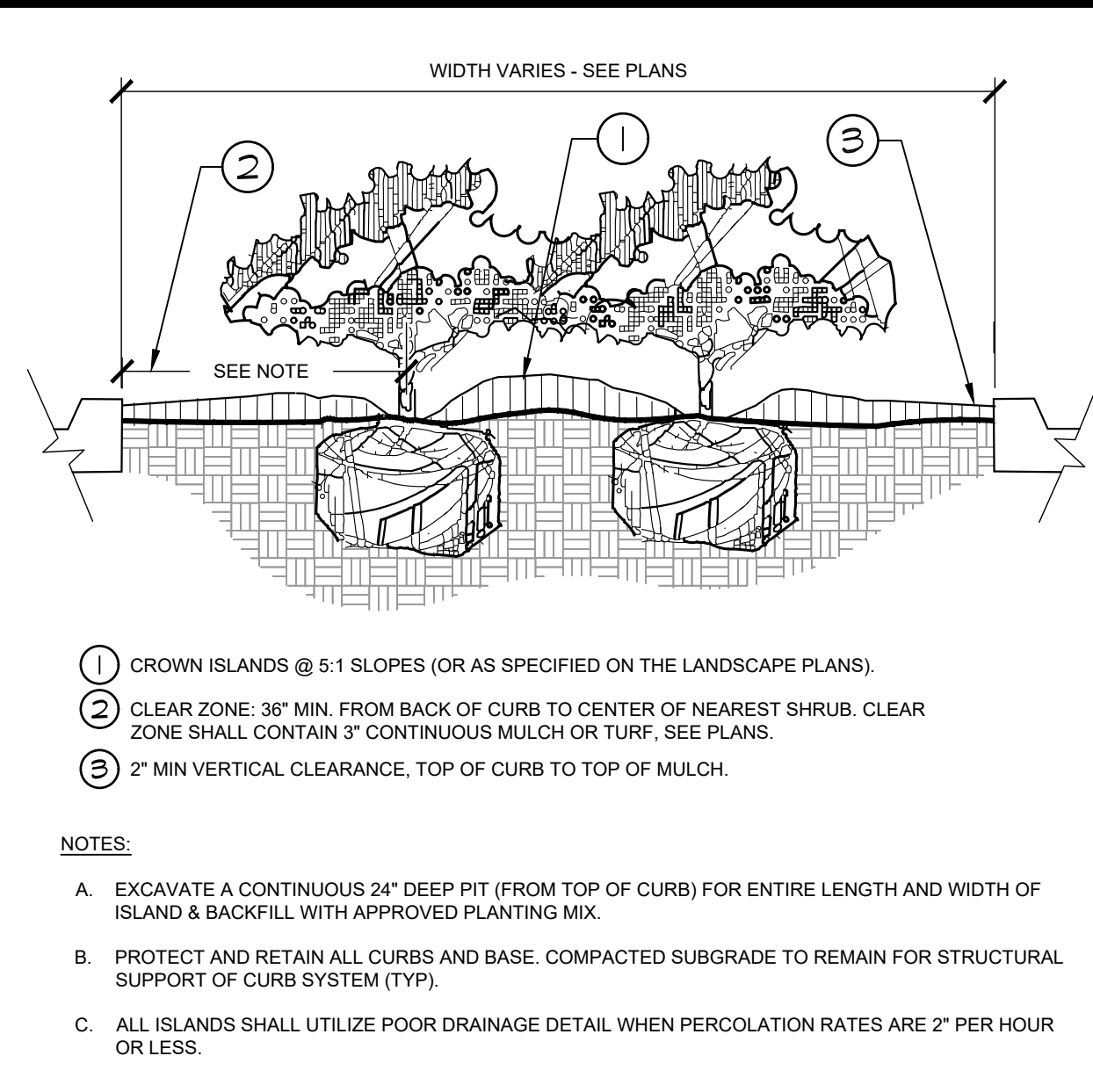

4 PLANTED PARKING LOT ISLANDS/MEDIANS  
SECTION

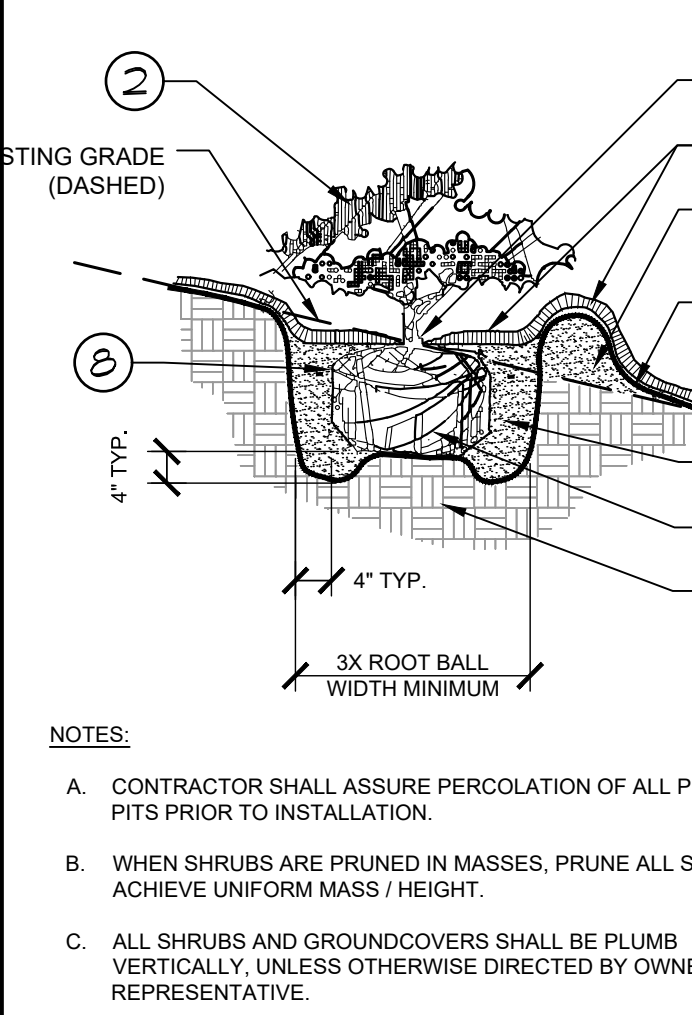

- 1 TOP OF SHRUB ROOTBALLS TO BE PLANTED 1" - 2" HIGH WITH SOIL MOUNDING UP TO THE TOP OF ROOTBALL.
  - 2 PRUNE SHRUBS AS DIRECTED BY OWNER'S REPRESENTATIVE.
  - 3 3" MINIMUM OF MULCH AS SPECIFIED, WHERE SHRUBS ARE PLACED IN MASSES, MULCH SHALL BE SPREAD IN A CONTINUOUS BED.
  - 4 SOIL BERM TO HOLD WATER. TOP OF PLANTING PIT BERM TO BE LEVEL ACROSS PIT. SLOPE DOWNHILL PORTION OF BERM AS REQUIRED TO MEET EXISTING GRADE. MULCH OVER EXPOSED TOPSOIL.
  - 5 FINISHED GRADE (SEE GRADING PLAN)
  - 6 PREPARED PLANTING SOIL AS SPECIFIED. (SEE LANDSCAPE NOTES).
  - 7 SCARIFY SIDES AND BOTTOM OF PLANTING PIT.
  - 8 FERTILIZER TABLETS (MAX 3" DEEP).
  - 9 UNDISTURBED NATIVE SOIL.
- NOTES:
- A. CONTRACTOR SHALL ASSURE PERCOLATION OF ALL PLANTING PITS PRIOR TO INSTALLATION.
  - B. WHEN SHRUBS ARE PRUNED IN MASSES, PRUNE ALL SHRUBS TO ACHIEVE UNIFORM MASS / HEIGHT.
  - C. ALL SHRUBS AND GROUNDCOVERS SHALL BE PLUMB VERTICALLY, UNLESS OTHERWISE DIRECTED BY OWNERS REPRESENTATIVE.

5 SHRUB/GROUNDCOVER PLANTING ON A SLOPE  
SECTION

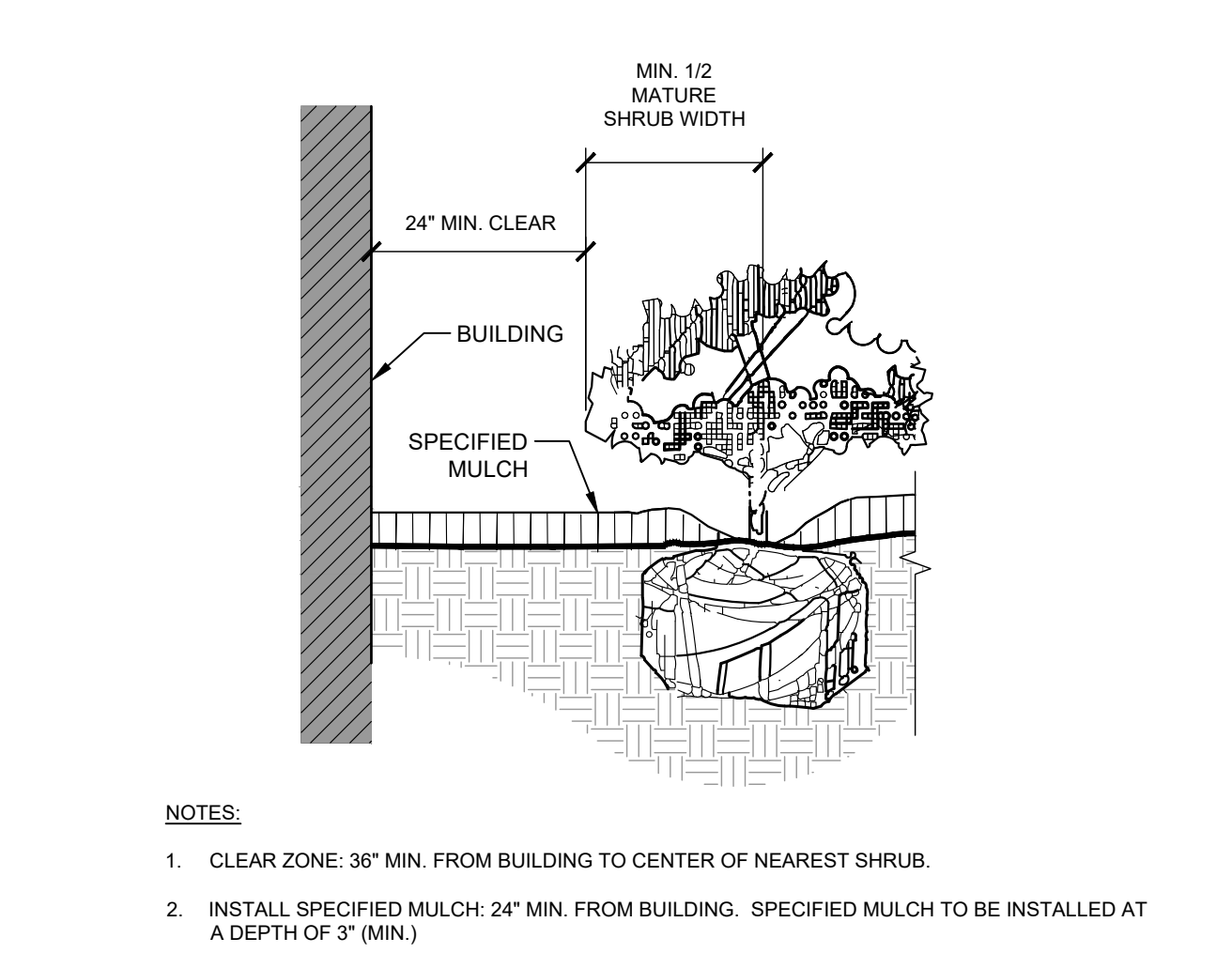

6 PLANTINGS ADJACENT TO BUILDINGS  
SECTION

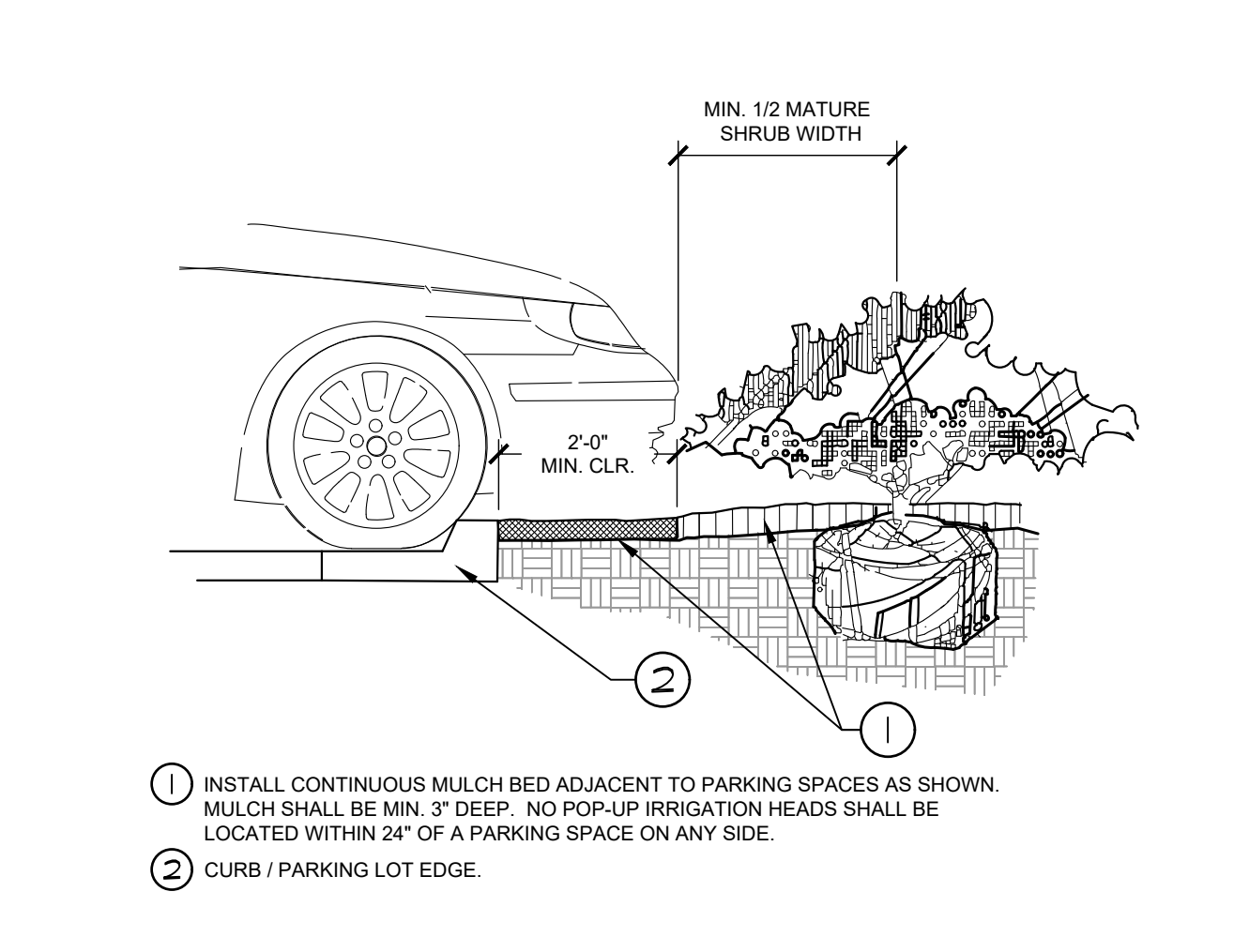

7 PARKING SPACE/CURB PLANTING  
SECTION

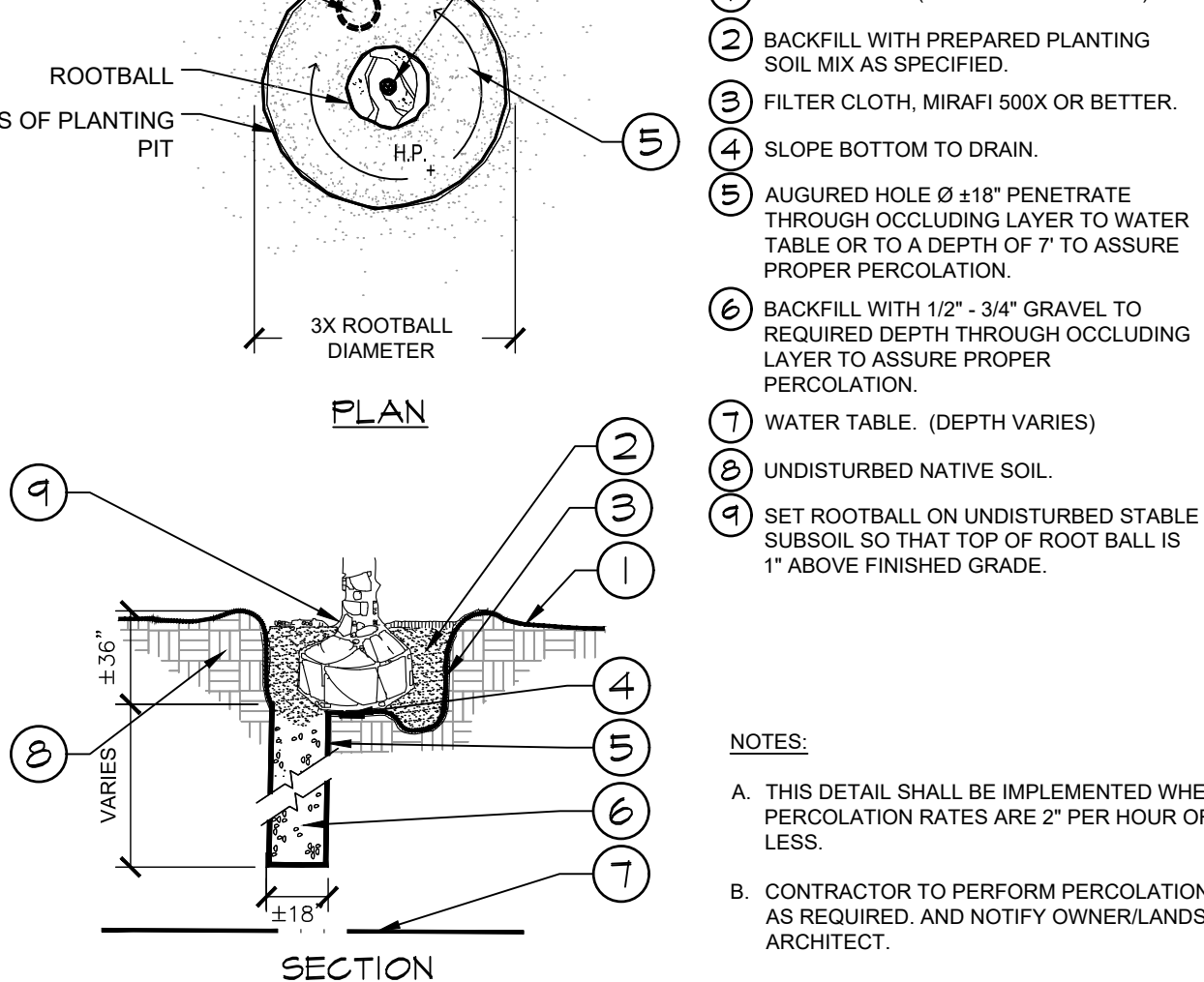

8 POOR DRAINAGE CONDITION  
SECTION / PLAN

NO.	REVISION	BY	DATE	APPROVED

**Kimley»Horn**  
 2019 KIMLEY-HORN AND ASSOCIATES, INC.  
 4582 South Ulster Street, Suite 1500  
 Denver, Colorado 80237 (303) 228-2300

DESIGNED BY: NBB  
 DRAWN BY: NBB  
 CHECKED BY: CPH  
 DATE: 11/14/19

**PARKER & PINE**  
 PARKER, CO  
 CONSTRUCTION DOCUMENTS  
 LANDSCAPE DETAILS

PRELIMINARY  
 FOR REVIEW ONLY  
 NOT FOR  
 CONSTRUCTION  
**Kimley»Horn**  
 Kimley-Horn and Associates, Inc.

PROJECT NO.  
 096502001  
 DRAWING NAME  
 096502001LA

L1.6

L:\\_den\_cj\096502001 - revised - Parker & Pine - CADD\sheet\096502001R.dwg Header: Christopher 10/8/2019 10:57 AM  
 THIS DOCUMENT, TOGETHER WITH THE CONCEPT AND DESIGN PRESENTED HEREIN, AS AN INSTRUMENT OF SERVICE IS INTENDED ONLY FOR THE SPECIFIC PURPOSE AND CLIENT FOR WHICH IT WAS PREPARED. REVIEW OF AND IMPROPER RELIANCE ON THIS DOCUMENT WITHOUT WRITTEN AUTHORIZATION AND ADAPTATION BY KIMLEY-HORN AND ASSOCIATES, INC. SHALL BE WITHOUT LIABILITY TO KIMLEY-HORN AND ASSOCIATES, INC.

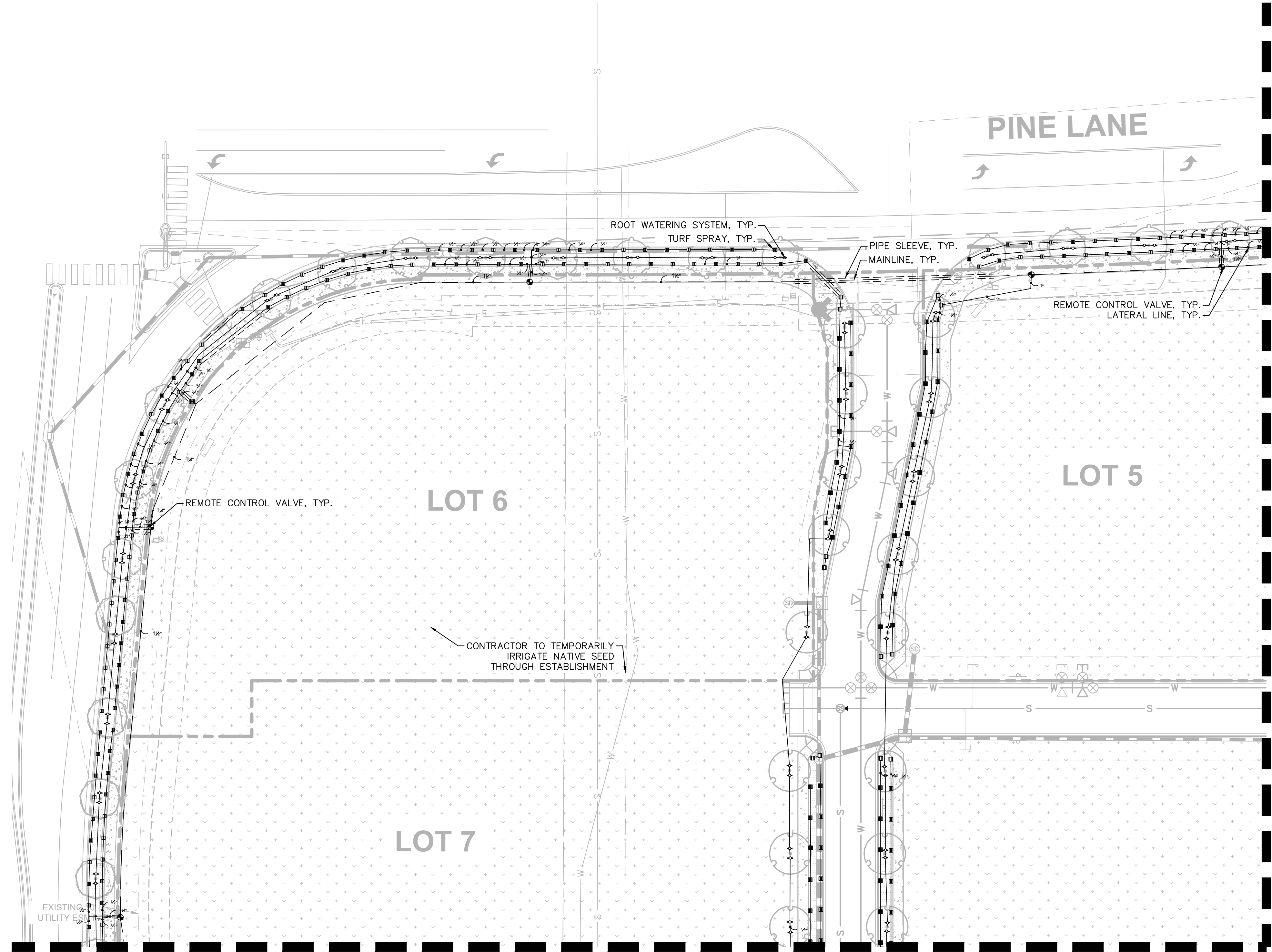

SEE SHEET L1.3 FOR CONTINUATION

SEE SHEET L1.2 FOR CONTINUATION

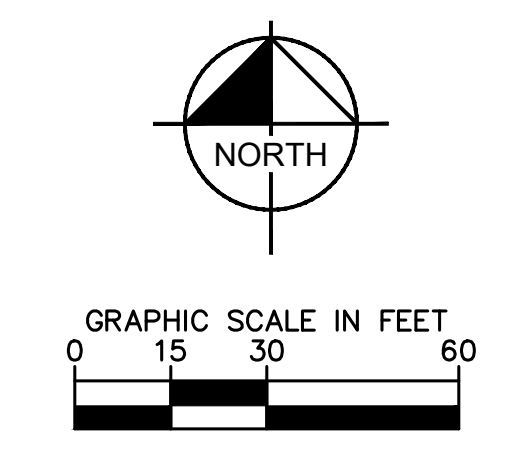

NO.	REVISION	BY	DATE	APPR

**Kimley»Horn**  
 2019 KIMLEY-HORN AND ASSOCIATES, INC.  
 4582 South Ulster Street, Suite 1500  
 Denver, Colorado 80237 (303) 228-2300

DESIGNED BY: DLS  
 DRAWN BY: ECZ  
 CHECKED BY: DLS  
 DATE: 11/14/19

**PARKER & PINE**  
 PARKER, CO  
 CONSTRUCTION DOCUMENTS  
 IRRIGATION PLAN

**PRELIMINARY**  
 FOR REVIEW ONLY  
 NOT FOR  
 CONSTRUCTION  
**Kimley»Horn**  
 Kimley-Horn and Associates, Inc.

PROJECT NO.  
 096502001  
 DRAWING NAME  
 096502001R

IR1.1

k:\gen\_civil\096502001\mixed use parker rd\CADD\plansheets\096502001R.dwg - Hepler, Christopher, 10/8/2019, 10:57 AM  
 2019 KIMLEY-HORN AND ASSOCIATES, INC. ALL RIGHTS RESERVED. THIS DOCUMENT IS UNCONTROLLED. ANY CHANGES TO THIS DOCUMENT SHALL BE WITHOUT LIABILITY TO KIMLEY-HORN AND ASSOCIATES, INC.

SEE SHEET IR1.1 FOR CONTINUATION

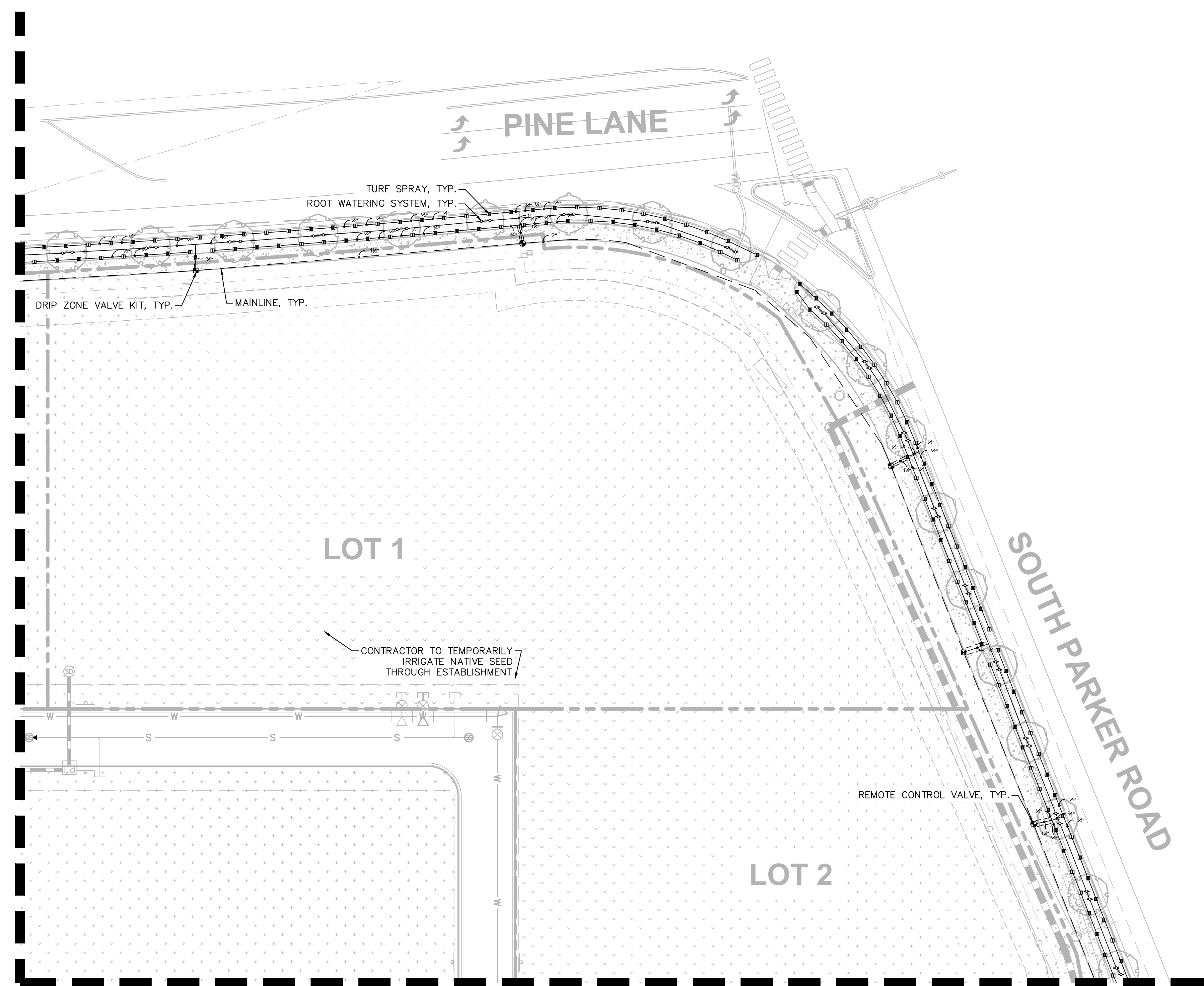

LOT 1

LOT 2

PINE LANE

SOUTH PARKER ROAD

TURF SPRAY, TYP.  
 ROOT WATERING SYSTEM, TYP.

DRIP ZONE VALVE KIT, TYP.  
 MAINLINE, TYP.

CONTRACTOR TO TEMPORARILY  
 IRRIGATE NATIVE SEED  
 THROUGH ESTABLISHMENT

REMOTE CONTROL VALVE, TYP.

SEE SHEET L1.4 FOR CONTINUATION

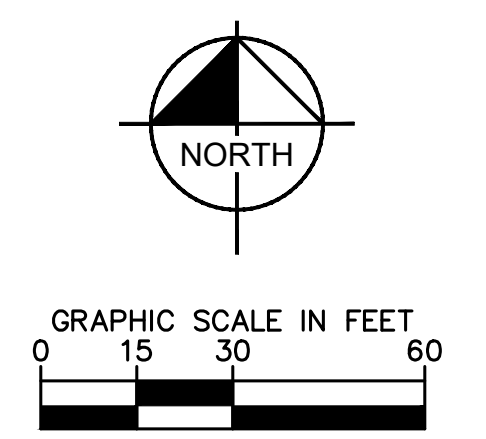

NO.	REVISION	BY	DATE	APPR.

**Kimley»Horn**  
 2019 KIMLEY-HORN AND ASSOCIATES, INC.  
 4562 South Ulster Street, Suite 1500  
 Denver, Colorado 80237 (303) 728-2300

DESIGNED BY: DLS  
 DRAWN BY: ECZ  
 CHECKED BY: DLS  
 DATE: 11/14/19

PARKER & PINE  
 PARKER, CO  
 CONSTRUCTION DOCUMENTS  
 IRRIGATION PLAN

PRELIMINARY  
 FOR REVIEW ONLY  
 NOT FOR  
 CONSTRUCTION  
**Kimley»Horn**  
 Kimley-Horn and Associates, Inc.

PROJECT NO.  
 096502001

DRAWING NAME  
 096502001R

IR1.2







