

Town of Parker

Parker and Pine Minor Development

Filing No. 1

Parker & Pine Retail
Final Drainage Report

MARCH 2020 | VERSION 1

Prepared By:

Kimley»»Horn

4582 South Ulster Street, Suite 1500

Denver, CO 80237

CERTIFICATION

ENGINEERS STATEMENT

This report for the final design of Parker & Pine Retail Development was prepared by me or under my direct supervision in accordance with the provisions of the Town of Parker Storm Drainage and Environmental Criteria Manual. I understand that the Town of Parker and its designated town authority do not and will not assume liability for drainage facilities designed by others.



Signature

Daniel L. Skeehan, P.E.

Colorado P.E. License No. 46391



03/11/2020

Seal and Date

TABLE OF CONTENTS

CERTIFICATION 1
ENGINEERS STATEMENT 1

VICINITY MAP..... 3

GENERAL LOCATION AND DESCRIPTION..... 3
LOCATION..... 4
DESCRIPTION OF PROPERTY 4
DESCRIPTION OF PROJECT..... 4

DRAINAGE BASINS AND SUB-BASINS..... 4
MAJOR DRAINAGE BASIN DESCRIPTION 5

DRAINAGE DESIGN CRITERIA 5
REGULATIONS 5
DEVELOPMENT DESIGN CRITERIA REFERENCE AND CONSTRAINTS 5
HYDROLOGIC CRITERIA..... 6
HYDRAULIC CRITERIA..... 6

DRAINAGE FACILITY DESIGN..... 6
GENERAL CONCEPT 6
SUB-BASIN DESCRIPTION 7
DETAINED SUB-BASINS 9
 Sub-Basins 1.1 – 18 9
UNDETAINED SUB-BASINS..... 10
 Sub-Basins 19, 20..... 10
PARKER AUTO PLAZA FINAL DRAINAGE REPORT COMPLIANCE 11
FLOODPLAIN DEVELOPMENT PERMIT 11

ENVIRONMENTAL PROTECTION CRITERIA 11
GENERAL..... 11
CONSTRUCTION BMP PLAN..... 11
PERMANENT BMP PLAN 11

CONCLUSIONS 12
COMPLIANCE WITH STANDARDS 12
DRAINAGE CONCEPT 12
SEDIMENT AND EROSION CONTROL CONCEPT 12

REFERENCES..... 13

APPENDIX..... 14

VICINITY MAP

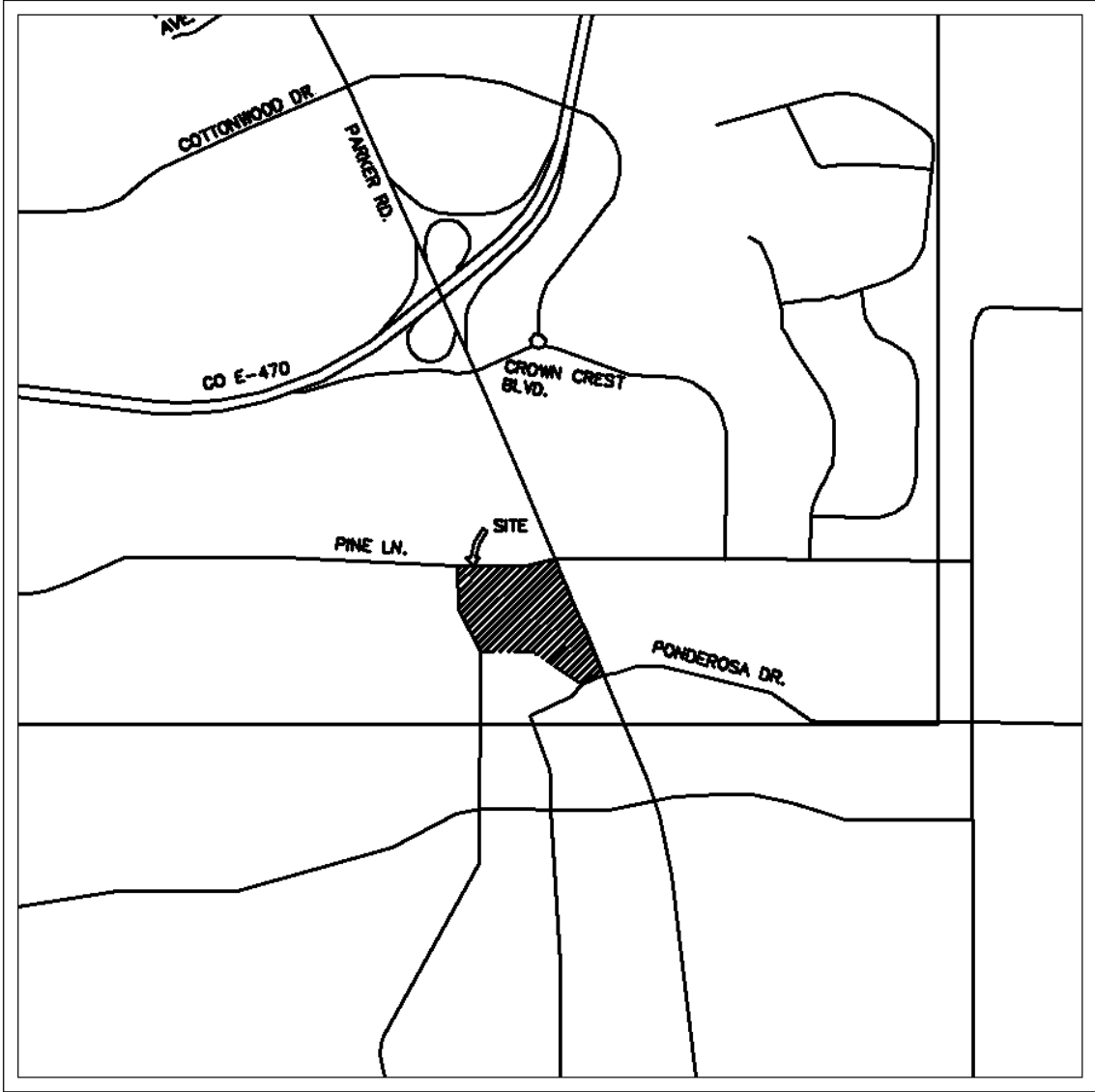

VICINITY MAP
1"=2,000'

GENERAL LOCATION AND DESCRIPTION

The purpose of this report is to outline the drainage plan for the Parker & Pine Retail Development located between Twenty Mile Road and Parker Road, south of Pine Lane in the Town of Parker, County of Douglas, State of Colorado (herein the "Project").

LOCATION

The proposed Parker & Pine Retail Development lies within 1 parcel of land, located in the southeast quarter of Section 9 and a part of the northeast quarter of section 16 within Township 6 South, Range 66 West of the Sixth Principal Meridian, Town of Parker, County of Douglas, State of Colorado (see Vicinity Map). South Parker Road (State Highway No. 83) borders the project to the east, Pine Lane borders the project to the north, and Twenty Mile Road to the west. An existing detention pond and Baldwin Gulch abut the project to the south. The Site is currently vacant.

DESCRIPTION OF PROPERTY

The Project Site is 15.952 acres in size, a majority of which is currently native grass and overgrown vegetation. The project slopes from east to west from an elevation of ± 5820 feet on the east side to an elevation of ± 5783 feet on the west side at a slope of about 3.5%. There is a flat area in the southeast corner of the property at an elevation of ± 5811 feet that prevents a portion of the site from flowing west. This southeast corner of the site flows south, directly into Baldwin Gulch.

Soils onsite are generally USCS Type BrD, Lo, and Sa as verified by the soil survey included in Appendix A. There are 4 existing storm sewer inlets adjacent to the property. The proposed site conditions will convey stormwater to the existing detention pond via overland sheet flows and a proposed underground storm drain system. Currently, there are no storm inlets or detention facility improvements located on the site. The existing site conditions sheet flow to an existing off-site detention basin and ultimately discharge into Baldwin Gulch.

Water quality treatment is provided by means of an extended detention basin with a water quality outlet structure. The existing detention basin is located adjacent to Baldwin Gulch on the southwest side of the Site. The controlled WQCV, EURV, and 100-year release will outfall to Baldwin Gulch.

DESCRIPTION OF PROJECT

The Project involves the construction of interior streets, vacant lots with native seeding, and utility mains including storm sewer infrastructure intended to convey flows for the phased site development. Modifications to an existing stormwater pond south of the site to current code is also in the scope of the project.

DRAINAGE BASINS AND SUB-BASINS

The Project falls within the limits of the “Parker Auto Plaza Final Drainage Report” (FDR), prepared by Kiowa Engineering Corporation dated July 12, 2004 and included in Appendix F, as part of the Parker Auto Plaza development. The Project will ensure that the requirements of the FDR are met. For a detailed look at the requirements and how they are met, refer to the “Existing Parker Auto Plaza Storm Sewer Requirements” of this report.

The FDR provides design for the overall development of approximately 52.7 acres. The Project includes sub-basins 1A, 2A, 3A and 4A from the FDR which total to 13.95 acres. The drainage map from the Parker Auto Plaza FDR is included in Appendix F. Portions of sub-basins 1C and 5C from the FDR are also included in the Project site as part of detained sub-basins. The Project also captures offsite runoff from approximately 0.33 acres between the property line on the east

side of the Project and the existing sidewalk in the right of way along South Parker Road. Runoff from basins 1A-4A were planned to be conveyed to the detention basin (noted as sub-basin 5A in the FDR) via an underground storm sewer system that has not been implemented. Sub-basins 1C and 5C were planned to flow directly into Baldwin Gulch via grassed swales and a separate storm sewer system. The Project detains runoff from a total of 15.81 acres, which includes the entirety of FDR sub-basins 1A, 2A, 3A and 5A, a majority of FDR sub-basins 4A and 1C, and approximately a third of FDR sub-basin 5C.

MAJOR DRAINAGE BASIN DESCRIPTION

Baldwin Gulch is mapped as a Zone AE, which is defined by FEMA as 'Areas subject to inundation by the 1-percent-annual-chance flood event determined by detailed methods' The existing FEMA Flood Insurance Rate Map (FIRM) is number 08035C0067G, effective date March 16, 2016.

The current FIRM Panel shows no portion of the subject property to be located within the 100-year floodplain; however, Baldwin Gulch is designated as a major drainageway by UDFCD. There are no planned improvements to the existing Baldwin Gulch.

The FIRM panel referenced above is included in Appendix B1. The overall drainage basin is mostly developed. The proposed development is ultimately tributary to Cherry Creek. Drainage facilities are provided to allow drainage into the detention pond on the southwest corner of the Site and ultimately discharging into Baldwin Gulch. The proposed Site consists of twenty-two (22) on-site drainage basins. Twenty (20) drainage basins are conveyed to the detention pond via overland flow or by storm sewer. There are 0.34 acres of off-site runoff included within the twenty (20) on-site basins that drain onsite and are conveyed to the existing detention pond via storm sewer. More specifically, sub-basins 3.0, 5.0, 7.0, 8.0, and 15.0 all account for portions of the off-site runoff totaling to 0.34 acres. Two (2) of the twenty-two (22) onsite drainage basins (sub-basins 19.0 and 20.0) drain overland into Pine Lane and Twenty Mile Road, mimicking conditions which currently exist onsite. One (1) of the twenty-two (22) drainage basins (sub-basin 18.0) drains directly into Baldwin Gulch, mimicking conditions which currently exist onsite. The existing detention pond discharges into Baldwin Gulch.

DRAINAGE DESIGN CRITERIA

REGULATIONS

There are no deviations from the Town of Parker and UDFCD floodplain regulations.

COMPLIANCE WITH TOWN'S STREAM PRESERVATION STANDARDS

There are no existing stream buffers within the Project area. Baldwin Gulch is preserved with no drainage upgrades required to maintain compliance with Town of Parker and UDFCD regulations.

DEVELOPMENT DESIGN CRITERIA REFERENCE AND CONSTRAINTS

The FIRM panel cited in the Major Drainage Basin Description Section shows no portion of the

Site to be located within the 100-year floodplain. The proposed storm facilities are in compliance with the Town of Parker Storm Drainage and Environmental Criteria Manual (the "CRITERIA") and the Urban Storm Drainage Criteria Manual (the "MANUAL"). Site drainage is not significantly impacted by such constraints as utilities or existing development.

The proposed approach includes pipe flow into an existing detention pond. Additional detail regarding onsite drainage patterns is provided in the Drainage Facility Design Section.

HYDROLOGIC CRITERIA

The 5-year and 100-year design storm events were used in determining rainfall and runoff for the proposed drainage system per Table 2.3 of the CRITERIA. Table 5.1 of the CRITERIA is the source for rainfall data for the 5-year and 100-year design storm events. Design runoff was calculated using the Rational Method for developed conditions as established in the CRITERIA and MANUAL. Runoff coefficients for the proposed development were determined using Table RO-5 of the MANUAL by calculating weighted impervious values for each specific site basin. The detention storage requirement was calculated using the same method and formulae used by Kiowa Engineering Corporation in the Parker Auto Plaza FDR.

An existing orifice plate placed in the first bay of a drop box outlet (Figure 2 of the Parker Auto Plaza FDR, UDFCD, Typical WQCV Outlet Structure Profiles) controls the release rate for the 10-year event. An orifice plate mounted to the second bay wall of the detention basin outlet structure controls the 100-year release rate. The release of flow is limited to 3.6 cubic feet per second (cfs) in the 10-year event and 13.1 cfs in the 100-year event. Flows from this existing detention basin discharge directly into Baldwin Gulch, and limited modifications (replacing existing orifice plate) to the existing outlet structure are being proposed.

HYDRAULIC CRITERIA

The proposed drainage facilities are designed in accordance with the CRITERIA and MANUAL. Floodplain identification was determined using FIRM panels by FEMA and information provided in the CRITERIA.

Hydrologic and hydraulic calculations are summarized in Appendix D.

DRAINAGE FACILITY DESIGN

GENERAL CONCEPT

The Project consists of interior streets, vacant lots with native seeding, and utility mains including storm sewer infrastructure intended to convey flows for the phased site development.

The Project provides water quality treatment by means of an existing water quality outlet structure and detention through an existing surface detention pond for the entirety of the site. The detention pond outfalls to Baldwin Gulch. Improvements to the pond will consist of a proposed forebay, trickle channel, and access road.

The Site has been divided into twenty-two (22) sub-basins, sub-basins 1.1 through 20.0, which represent small sub-basins that are tributary to the adjacent right-of-way and Baldwin Gulch which mimics current site conditions. Ultimately the developed runoff is conveyed downstream to the existing detention pond. Further information regarding the basins and drainage patterns

can be found in Appendix C.

SUB-BASIN DESCRIPTION

Sub-basin 1.1 is 1.43 acres consisting of open lot with assumed imperviousness of 85%. Runoff will enter Storm Stub 1.1 and be conveyed to Pond 1 through a private underground storm sewer. The runoff coefficients for this sub-basin are 4.93 and 10.37 for the 5-year and 100-year storm, respectively. If Storm Stub 1.1 were to plug, the runoff for the basin would flow east onto sub-basin 9.0 and drain into inlet A04.

Sub-basin 1.2 is 1.97 acres consisting of open lot with assumed imperviousness of 85%. Runoff will enter inlet B01 and be conveyed to Pond 1 through a private underground storm sewer. The runoff coefficients for this sub-basin are 6.77 and 14.25 for the 5-year and 100-year storm, respectively. If inlet B01 were to plug, the runoff for the basin would flow south onto sub-basin 13.0 and drain into inlet B00.

Sub-basin 2.0 is 0.88 acres consisting of open lot with assumed imperviousness of 85%. Runoff will enter inlet C00.1 and be conveyed to Pond 1 through a private underground storm sewer. The runoff coefficients for this sub-basin are 3.00 and 6.33 for the 5-year and 100-year storm, respectively. If inlet C00.1 were to plug, the runoff for the basin would flow south onto sub-basin 10.0 and drain into inlet C00.

Sub-basin 3.0 is 1.97 acres consisting of open lot with assumed imperviousness of 85%. Runoff will enter inlet C01.1 and be conveyed to Pond 1 through a private underground storm sewer. The runoff coefficients for this sub-basin are 6.80 and 14.29 for the 5-year and 100-year storm, respectively. If inlet C01.1 were to plug, the runoff for the basin would flow south and drain onto sub-basin 11.0 and drain into inlet C01.

Sub-basin 4.1 is 1.14 acres consisting of open lot with assumed imperviousness of 85%. Runoff will enter inlet B02 and be conveyed to Pond 1 through a private underground storm sewer. The runoff coefficients for this sub-basin are 3.91 and 8.23 for the 5-year and 100-year storm, respectively. If inlet B02 were to plug, the runoff for the basin would flow south onto sub-basin 16.0 and drain into inlet A01.

Sub-basin 4.2 is 0.77 acres consisting of open lot with assumed imperviousness of 85%. Runoff will enter Storm Stub 4.2 and be conveyed to Pond 1 through a private underground storm sewer. The runoff coefficients for this sub-basin are 2.65 and 5.56 for the 5-year and 100-year storm, respectively. If inlet Storm Stub 4.2 were to plug, the runoff for the basin would flow south onto sub-basin 14.0 and drain into inlet B03.

Sub-basin 5.0 is 1.13 acres consisting of open lot with assumed imperviousness of 85%. Runoff will enter inlet B05.1 and be conveyed to Pond 1 through a private underground storm sewer. The runoff coefficients for this sub-basin are 3.89 and 8.18 for the 5-year and 100-year storm, respectively. If inlet B05.1 were to plug, the runoff for the basin would flow south onto sub-basin 15 and drain into inlet B05.

Sub-basin 6.0 is 2.22 acres consisting of open lot with assumed imperviousness of 85%. Runoff will enter via a connection to manhole D01 and be conveyed to Pond 1 through a private underground storm sewer. The runoff coefficients for this sub-basin are 7.62 and 16.06 for the 5-year and 100-year storm, respectively. If the connection to manhole D01 were to clog, the runoff for the basin would flow south directly into Baldwin Gulch.

Sub-basin 7.0 is 1.02 acres consisting of open lot with assumed imperviousness of 85%. Runoff will enter inlet B07.1 and be conveyed to Pond 1 through a private underground storm sewer. The runoff coefficients for this sub-basin are 3.48 and 7.35 for the 5-year and 100-year storm, respectively. If inlet B07.1 were to plug, the runoff for the basin would flow south onto sub-basin 17 and drain into inlet B08.

Sub-basin 8.0 is 1.94 acres consisting of open lot with assumed imperviousness of 85%. Runoff will enter inlet B08.1 and be conveyed to Pond 1 through a private underground storm sewer. The runoff coefficients for this sub-basin are 6.13 and 12.90 for the 5-year and 100-year storm, respectively. If inlet B08.1 were to plug, the runoff for the basin would flow west onto sub-basin 17 and drain into inlet B08.

Sub-basin 9.0 is 0.10 acres consisting of streets, curb, and gutter. Runoff will enter inlet A04 and be conveyed to Pond 1 through a private underground storm sewer. The runoff coefficients for this sub-basin are 0.42 and 0.81 for the 5-year and 100-year storm, respectively. If the inlet were to plug, the runoff for the basin would flow south onto sub-basin 12 and drain into inlet A02.

Sub-basin 10.0 is 0.16 acres consisting of streets, curb, and gutter. Runoff will enter inlet C00 and be conveyed to Pond 1 through a private underground storm sewer. The runoff coefficients for this sub-basin are 0.65 and 1.26 for the 5-year and 100-year storm, respectively. If inlet C00 were to plug, the runoff for the basin would flow west onto sub-basin 12 and drain into inlet A02.

Sub-basin 11.0 is 0.21 acres consisting of streets, curb, and gutter. Runoff will enter inlet C01 and be conveyed to Pond 1 through a private underground storm sewer. The runoff coefficients for this sub-basin are 0.86 and 1.66 for the 5-year and 100-year storm, respectively. If inlet C01 were to plug, the runoff for the basin would flow west onto sub-basin 10 and drain into inlet C00.

Sub-basin 12.0 is 0.14 acres consisting of streets, curb, and gutter. Runoff will enter inlet A02 and be conveyed to Pond 1 through a private underground storm sewer. The runoff coefficients for this sub-basin are 0.57 and 1.09 for the 5-year and 100-year storm, respectively. If inlet A02 were to plug, the runoff for the basin would flow south into sub-basin 16.0 and drain into inlet A01.

Sub-basin 13.0 is 0.08 acres consisting of streets, curb, and gutter. Runoff will enter inlet B00 and be conveyed to Pond 1 through a private underground storm sewer. The runoff coefficients for this sub-basin are 0.32 and 0.62 for the 5-year and 100-year storm, respectively. If inlet B00 were to plug, the runoff for the basin would flow south and west onto sub-basin 19, flowing offsite following its historic path.

Sub-basin 14.0 is 0.17 acres consisting of streets, curb, and gutter. Runoff will enter inlet B03 and be conveyed to Pond 1 through a private underground storm sewer. The runoff coefficients for this sub-basin are 0.67 and 1.30 for the 5-year and 100-year storm, respectively. If inlet B03 were to plug, the runoff for the basin would flow west onto sub-basin 16.0 and drain into inlet A01.

Sub-basin 15.0 is 0.18 acres consisting of streets, curb, and gutter. Runoff will enter inlet B05 and be conveyed to Pond 1 through a private underground storm sewer. The runoff coefficients for this sub-basin are 0.72 and 1.40 for the 5-year and 100-year storm, respectively. If inlet B05 were to plug, the runoff for the basin would flow west onto sub-basin 17 and drain into inlet B08.

Sub-basin 16.0 is 0.17 acres consisting of streets, curb, and gutter. Runoff will be conveyed to

inlet A01 and outfall into Pond 1 through future private underground storm sewer. The runoff coefficients for this sub-basin are 0.67 and 1.30 for the 5-year and 100-year storm, respectively. This sub-basin will sheet flow directly into Pond 1.

Sub-basin 17.0 is 0.11 acres consisting of streets, curb, and gutter. Runoff will enter inlet B08 and be conveyed to Pond 1 through a private underground storm sewer. The runoff coefficients for this sub-basin are 0.45 and 0.87 for the 5-year and 100-year storm, respectively.

Sub-basin 18.0 is 0.39 acres consisting of landscaping. Runoff will sheet flow to Baldwin Gulch, following its historic path. The runoff coefficients for this sub-basin are 1.59 and 3.09 for the 5-year and 100-year storm, respectively.

Sub-basin 19.0 is 0.11 acres consisting of streets, curb, and gutter. Runoff will flow onto Twenty Mile Road, following its historic path. The runoff coefficients for this sub-basin are 0.45 and 0.88 for the 5-year and 100-year storm, respectively.

Sub-basin 20.0 is 0.03 acres consisting of streets, curb, and gutter. Runoff will flow onto Pine Lane, following its historic path. The runoff coefficients for this sub-basin are 0.11 and 0.22 for the 5-year and 100-year storm, respectively.

Runoff from the proposed development will generally be collected by means of curb and gutter in the paved driveways and access roads within each delineated basin area. The runoff collected from each basin will be conveyed to the existing detention pond at the southwest corner of the Site. The controlled stormwater release from the detention and water quality structures will be conveyed through the existing outlet structure into Baldwin Gulch.

There are two (2) drainage basins (0.14 acres) of the Project Site that drain off-site, following their historic paths. Sub-basins 19.0 & 20.0 drain into the adjacent right-of way to the North and West. These drainage basins represent the landscape area between the perimeter buildings and the adjacent roadways (Twenty Mile Road to the west and Pine Lane to the north).

DETAINED SUB-BASINS

Sub-Basins 1.1 – 18.0

Sub-basins 1.1-18.0 are bound between Twenty Mile Road, Pine Lane and Baldwin Gulch. Some sub-basins being detained on-site include a total of 0.34 acres of off-site runoff. Sub-basins 3.0, 5.0, 7.0, 8.0, and 15.0 all account for portions of the off-site runoff being detained on-site. Each sub-basin contains a combination of paved areas, landscaping and streets. Overland flows will be directed to catch basins throughout the site. Curb inlets and grate inlets have been designed to accommodate the 100-yr storm. The landscaping areas overland flow to grate inlets or curb and gutter within each respective sub-basin. Runoff from the sub-basins is conveyed through an underground storm sewer system to the existing detention pond on the southwest corner of the site.

Refer to Table 1 for a summary of areas and post-development flows for the detained sub-basins.

Table 1. Runoff Summary for All Detained Sub-Basins

Runoff Summary			
BASIN ID	AREA	Q ₅	Q ₁₀₀
	Ac	CFS	CFS
1.1	1.43	4.93	10.37
1.2	1.97	6.77	14.25
2.0	0.88	3.00	6.33
3.0	1.97	6.80	14.29
4.1	1.14	3.91	8.23
4.2	0.77	2.65	5.56
5.0	1.13	3.89	8.18
6.0	2.22	7.62	16.06
7.0	1.02	3.48	7.35
8.0	1.94	6.13	12.90
9.0	0.10	0.42	0.81
10.0	0.16	0.65	1.26
11.0	0.21	0.86	1.66
12.0	0.14	0.57	1.09
13.0	0.08	0.32	0.62
14.0	0.17	0.67	1.30
15.0	0.18	0.72	1.40
16.0	0.17	0.67	1.30
17.0	0.11	0.45	0.87
18.0	0.39	1.59	3.09

UNDETAINED SUB-BASINS

Sub-Basins 19.0, and 20.0

Sub-basins 19.0, and 20.0 are a total of 0.14 acres in size and are not detained. These sub-basins follow their historic flows onto the public right of way and into Baldwin Gulch.

Table 2. Runoff Summary for Undetained Sub-Basins

Runoff Summary			
BASIN ID	AREA	Q ₅	Q ₁₀₀
	Ac	CFS	CFS
19.0	0.11	0.45	0.88
20.0	0.03	0.11	0.22

PARKER AUTO PLAZA FINAL DRAINAGE REPORT COMPLIANCE

The Parker Auto Plaza Final Drainage Report, dated July 12, 2004 was prepared as part of the Parker Auto Plaza Development by Kiowa Engineering Corporation.

The FDR extended detention basin is sized to store 15.45 acres of a proposed 95% impervious site. The Project extended detention basin will actually detain 15.81 acres of the proposed 85% impervious site.

The existing detention basin was sized based on a required 10-year and 100-year capacity of 2.06 ac-ft and 2.97 ac-ft, respectively. The Project site only requires 1.26 ac-ft and 2.13 ac-ft for the 10-year and 100-year capacities, respectively. The Project's required volumes were calculated to include WQCV capture volume. Based on this approach, the drainage design provided for the Project is in keeping with the Parker Auto Plaza FDR. Appendix D5 shows the calculations for the required 10-year and 100-year storage capacities for proposed development configuration.

FLOODPLAIN DEVELOPMENT PERMIT

A floodplain development permit from the Town of Parker is not required.

ENVIRONMENTAL PROTECTION CRITERIA

GENERAL

The Site is influenced by Baldwin Gulch. Baldwin Gulch is in the Town of Parker and Urban Drainage and Flood Control District jurisdictions. No impacts to threatened or endangered species are anticipated as a result of the Project, and the Project is understood to comply with the State and Federal environmental permitting regulations.

CONSTRUCTION BMP PLAN

Construction BMPs will be used throughout the redevelopment of the Site in order to comply with section 8.2 of the CRITERIA. Construction BMPs implemented onsite include temporary sediment basins, diversion ditches, silt fence and construction fence around the perimeter of the Site, vehicle tracking control, and a concrete washout area. The full list of construction BMPs to be implemented is shown on sheets C3.0- C3.11 of the Project's Civil Construction Documents.

PERMANENT BMP PLAN

The permanent plan to implement BMPs was designed in accordance with section 8.3 of the CRITERIA. For this Tier 3 redevelopment according to the CRITERIA, the primary permanent BMP that will be implemented is the existing detention pond for the Site drainage. The pond will satisfy the requirements for the permanent BMPs onsite.

CONCLUSIONS

COMPLIANCE WITH STANDARDS

The drainage design presented within this report conforms to the Town of Parker Storm Drainage and Environmental Criteria Manual. The major drainageway in the area, Baldwin Gulch, will not be adversely affected by the Project, and the Project meets Urban Drainage and Flood Control District requirements.

DRAINAGE CONCEPT

The drainage design discussed herein effectively controls the storm runoff from the Project by conveying developed runoff to the detention pond at the southwest portion of the Site. The proposed 10-year and 100-year volume requirements fall below the Parker Auto Plaza FDR's 10-year and 100-year volume requirements, to which the existing detention pond was designed. The existing outlet structure and release rates will not be modified as part of the proposed development. The released drainage from the pond is carried through a storm sewer and outfalls into Baldwin Gulch.

SEDIMENT AND EROSION CONTROL CONCEPT

The Construction BMP plans are designed to prevent erosion within the Site during and after construction. BMPs are in place to prevent erosion during construction including a temporary sediment basin, diversion ditch, silt fence around the perimeter of the Site, vehicle tracking control, and a concrete washout area. The forebay structure will prevent erosion at the bottom of the pond. Furthermore, the proposed concrete trickle channels within the pond will prevent erosion in the permanent condition.

REFERENCES

1. Town of Parker Storm Drainage and Environmental Criteria Manual, February 1996, Revised and Adopted February 2014.
2. Urban Drainage and Flood Control District Drainage Criteria Manual (UDFCDCM), Vol. 1, prepared by Wright-McLaughlin Engineers, June 2001, with latest revisions.
3. Flood Insurance Rate Map, Douglas County, Colorado and Incorporated Areas, Map Number 08035C0067G, Revised March 16, 2016, prepared by the Federal Emergency Management Agency (FEMA).
4. Parker Auto Plaza Final Drainage Report, July 12, 2004, prepared by Kiowa Engineering Corporation.

APPENDIX

APPENDIX A - HYDROLOGIC SOIL GROUP MAP

Hydrologic Soil Group—Castle Rock Area, Colorado
(Web Soil Survey)

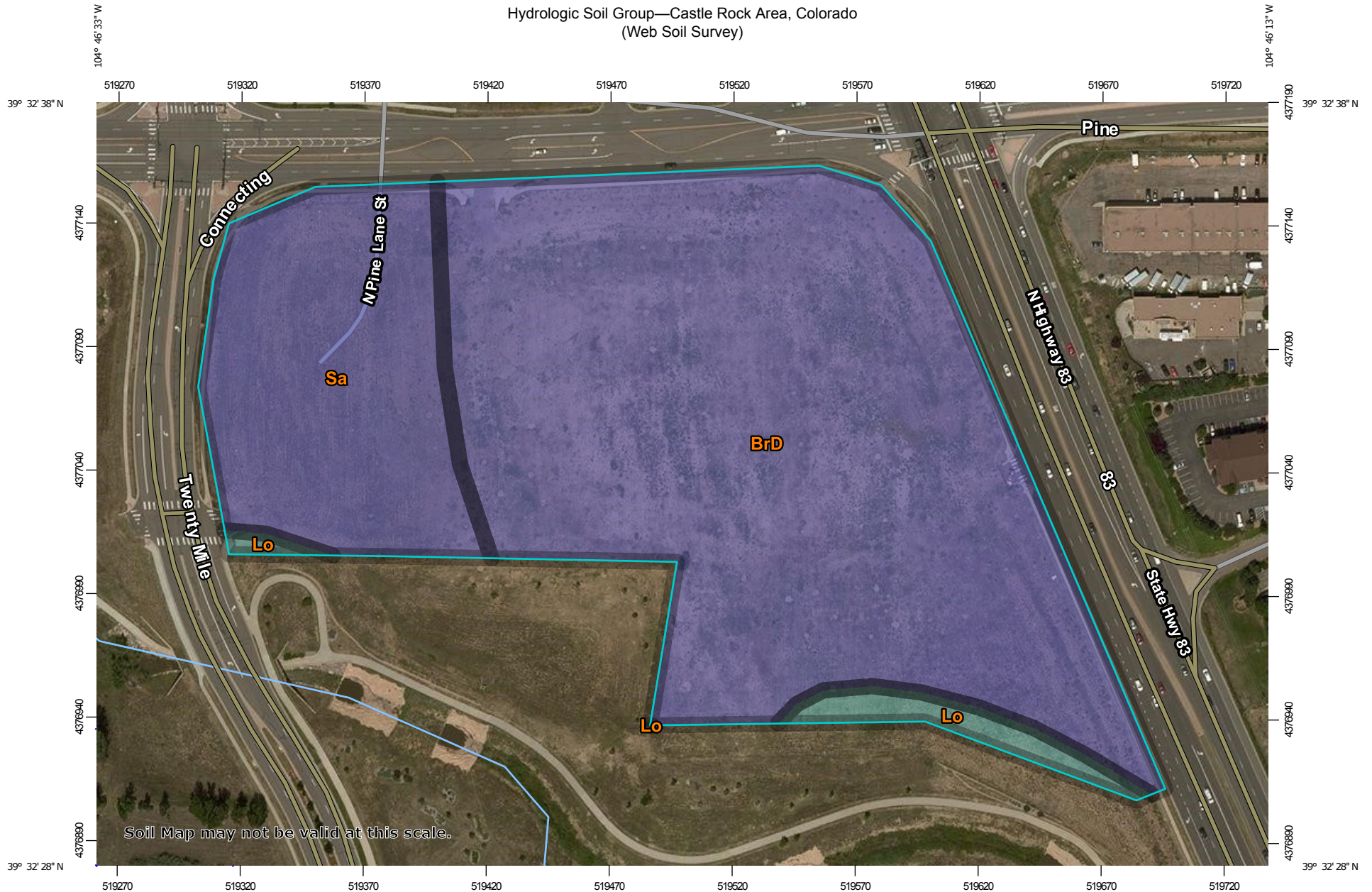

Map Scale: 1:2,180 if printed on A landscape (11" x 8.5") sheet.

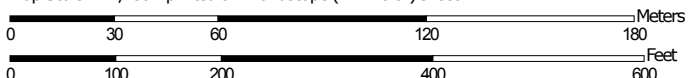

Map projection: Web Mercator Corner coordinates: WGS84 Edge tics: UTM Zone 13N WGS84



MAP LEGEND

Area of Interest (AOI)









 Area of Interest (AOI)

Soils

Soil Rating Polygons





 A
 A/D
 B
 B/D
 C
 C/D
 D
 Not rated or not available

Soil Rating Lines

 A
 A/D
 B
 B/D
 C
 C/D
 D
 Not rated or not available

Soil Rating Points





 A
 A/D
 B
 B/D

 C
 C/D
 D
 Not rated or not available

Water Features

 Streams and Canals

Transportation

 Rails
 Interstate Highways
 US Routes
 Major Roads
 Local Roads

Background

 Aerial Photography

MAP INFORMATION

The soil surveys that comprise your AOI were mapped at 1:20,000.

Warning: Soil Map may not be valid at this scale.

Enlargement of maps beyond the scale of mapping can cause misunderstanding of the detail of mapping and accuracy of soil line placement. The maps do not show the small areas of contrasting soils that could have been shown at a more detailed scale.

Please rely on the bar scale on each map sheet for map measurements.

Source of Map: Natural Resources Conservation Service
 Web Soil Survey URL:
 Coordinate System: Web Mercator (EPSG:3857)

Maps from the Web Soil Survey are based on the Web Mercator projection, which preserves direction and shape but distorts distance and area. A projection that preserves area, such as the Albers equal-area conic projection, should be used if more accurate calculations of distance or area are required.

This product is generated from the USDA-NRCS certified data as of the version date(s) listed below.

Soil Survey Area: Castle Rock Area, Colorado
 Survey Area Data: Version 9, Sep 22, 2016

Soil map units are labeled (as space allows) for map scales 1:50,000 or larger.

Date(s) aerial images were photographed: Jun 10, 2014—Aug 21, 2014

The orthophoto or other base map on which the soil lines were compiled and digitized probably differs from the background imagery displayed on these maps. As a result, some minor shifting of map unit boundaries may be evident.

Hydrologic Soil Group

Hydrologic Soil Group— Summary by Map Unit — Castle Rock Area, Colorado (CO622)				
Map unit symbol	Map unit name	Rating	Acres in AOI	Percent of AOI
BrD	Bresser sandy loam, cool, 5 to 9 percent slopes	B	11.2	73.8%
Lo	Loamy alluvial land	C	0.5	3.3%
Sa	Sampson loam	B	3.5	22.9%
Totals for Area of Interest			15.2	100.0%

Description

Hydrologic soil groups are based on estimates of runoff potential. Soils are assigned to one of four groups according to the rate of water infiltration when the soils are not protected by vegetation, are thoroughly wet, and receive precipitation from long-duration storms.

The soils in the United States are assigned to four groups (A, B, C, and D) and three dual classes (A/D, B/D, and C/D). The groups are defined as follows:

Group A. Soils having a high infiltration rate (low runoff potential) when thoroughly wet. These consist mainly of deep, well drained to excessively drained sands or gravelly sands. These soils have a high rate of water transmission.

Group B. Soils having a moderate infiltration rate when thoroughly wet. These consist chiefly of moderately deep or deep, moderately well drained or well drained soils that have moderately fine texture to moderately coarse texture. These soils have a moderate rate of water transmission.

Group C. Soils having a slow infiltration rate when thoroughly wet. These consist chiefly of soils having a layer that impedes the downward movement of water or soils of moderately fine texture or fine texture. These soils have a slow rate of water transmission.

Group D. Soils having a very slow infiltration rate (high runoff potential) when thoroughly wet. These consist chiefly of clays that have a high shrink-swell potential, soils that have a high water table, soils that have a claypan or clay layer at or near the surface, and soils that are shallow over nearly impervious material. These soils have a very slow rate of water transmission.

If a soil is assigned to a dual hydrologic group (A/D, B/D, or C/D), the first letter is for drained areas and the second is for undrained areas. Only the soils that in their natural condition are in group D are assigned to dual classes.

Rating Options

Aggregation Method: Dominant Condition

Component Percent Cutoff: None Specified

Tie-break Rule: Higher

APPENDIX B1 - FEMA FIRM PANEL

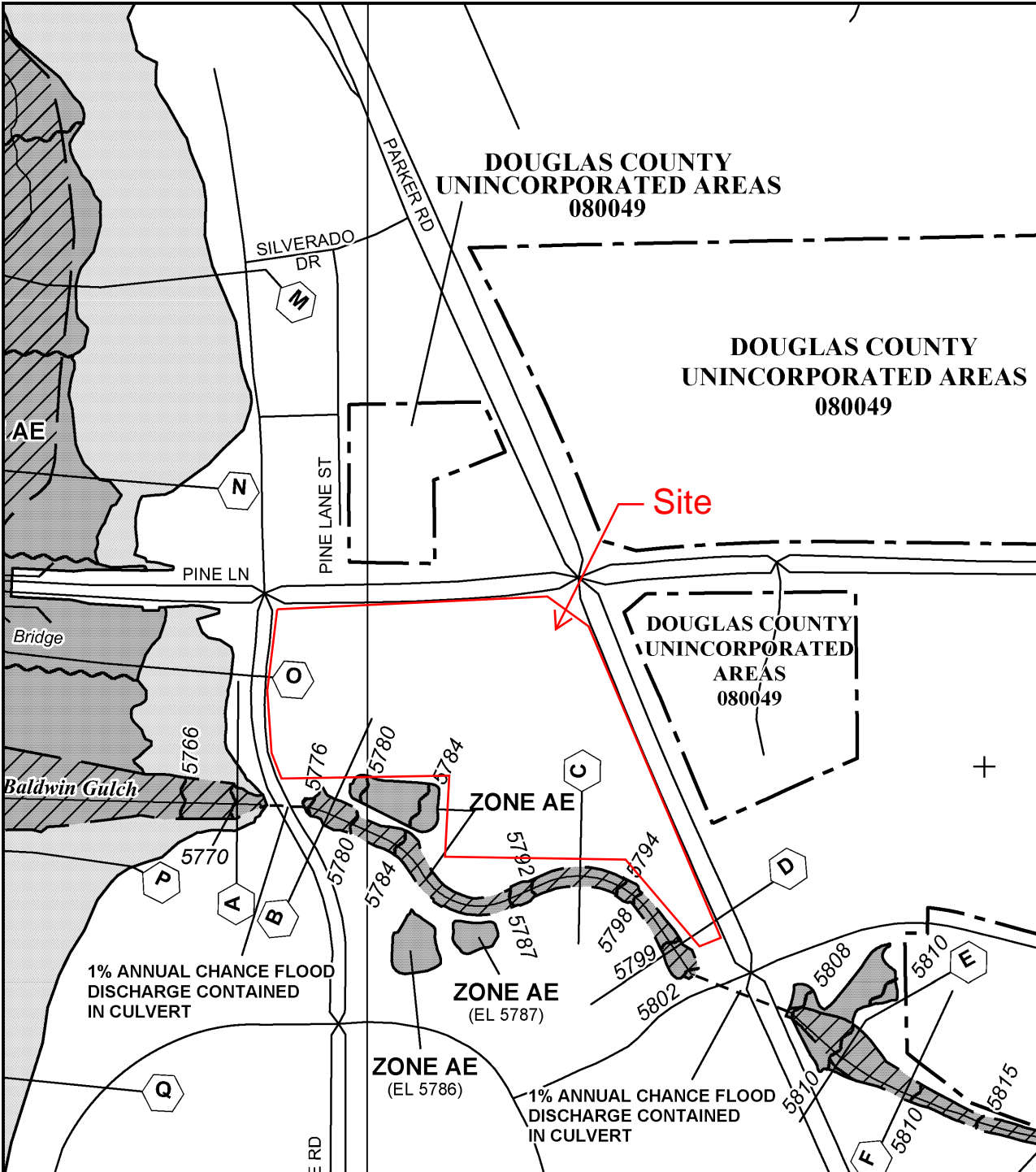

MAP SCALE 1" = 500'

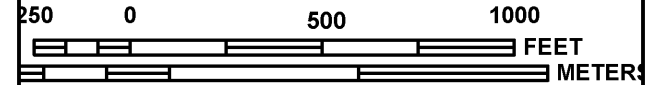

**DOUGLAS COUNTY
UNINCORPORATED AREAS
080049**

**DOUGLAS COUNTY
UNINCORPORATED AREAS
080049**

Site

**DOUGLAS COUNTY
UNINCORPORATED
AREAS
080049**

ZONE AE

**ZONE AE
(EL 5787)**

**ZONE AE
(EL 5786)**

**1% ANNUAL CHANCE FLOOD
DISCHARGE CONTAINED
IN CULVERT**

**1% ANNUAL CHANCE FLOOD
DISCHARGE CONTAINED
IN CULVERT**

NATIONAL FLOOD INSURANCE PROGRAM

PANEL 0067G

FIRM
FLOOD INSURANCE RATE MAP
**DOUGLAS COUNTY,
COLORADO**
AND INCORPORATED AREAS

PANEL 67 OF 495
(SEE MAP INDEX FOR FIRM PANEL LAYOUT)

CONTAINS:

COMMUNITY	NUMBER	PANEL	SUFFIX
DOUGLAS COUNTY	080049	0067	G
PARKER, TOWN OF	080310	0067	G

Notice to User: The **Map Number** shown below should be used when placing map orders; the **Community Number** shown above should be used on insurance applications for the subject community.



**MAP NUMBER
08035C0067G**
**MAP REVISED
MARCH 16, 2016**

Federal Emergency Management Agency

This is an official copy of a portion of the above referenced flood map. It was extracted using F-MIT On-Line. This map does not reflect changes or amendments which may have been made subsequent to the date on the title block. For the latest product information about National Flood Insurance Program flood maps check the FEMA Flood Map Store at www.msc.fema.gov

APPENDIX B2 – RAINFALL DATA

5. HYDROLOGIC CRITERIA

5.1 INTRODUCTION

This section presents the criteria and methodology for determining storm runoff design peaks and volumes to be used in the Town of Parker for preparation of storm drainage plans and facility design. In general, hydrologic analysis of the initial and major storm events for both the historic and fully developed site conditions is required. In addition to the hydrologic analysis for a site, a hydrologic analysis should be performed for all off site basins that impact the proposed site. The Town of Parker adopts procedures prescribed by the Urban Drainage and Flood Control District (UDFCD) for performing hydrologic analysis. These procedures may be found in the Rainfall and Runoff sections of the MANUAL. Standards and technical criteria found in the MANUAL should be followed except where superseded by specific requirements of this manual.

5.2 DESIGN RAINFALL

For any storm runoff technique, design rainfall must first be established. The design rainfall data to be used for the Town of Parker were obtained from NOAA Atlas 2, Precipitation– Frequency Atlas of the Western United States, Volume III– Colorado. The design storm events developed and utilized are the same as those used by UDFCD.

The one-hour point rainfall depths for different frequency events are shown in Table 5.1 herein. Rainfall intensity as a function of the one-hour point rainfall and the time of concentration can be approximated by the following equation which appears in the MANUAL as Equation RA-5.

$$I = (28.5P_1)/(10+t_c)^{0.786}$$

Where, I = rainfall intensity (in/hr)
 P_1 = one-hour point rainfall depth (in)
 t_c = time of concentration (min)

Graphical presentation of the equation is shown as the Time-Intensity-Frequency curves in Figure 5.1 herein. Rainfall intensity for use in the Rational Method may be taken from Figure 5.1 or calculated using the equation.

TABLE 5.1
ONE-HOUR POINT RAINFALL

Frequency of Design Event (yr)	One-hour Point Rainfall, P ₁ (in)
2	0.99
5	1.39
10	1.64
25	1.98
50	2.31
100	2.60

5.3 FLOOD HYDROLOGY OVERVIEW

Various methods exist to determine appropriate flood peaks or hydrographs for storm drainage planning and design. Methods for determining flood peaks or hydrographs are the Rational Method, the Colorado Urban Hydrograph Procedure (CUHP), and Urban Drainage Stormwater Management (UDSWM) model. The Town of Parker discourages the use of computer models other than CUHP and UDSWM since these programs are preferred, if not required, by UDFCD for studies involving major drainageways where UDFCD approval is sought or where maintenance eligibility is requested.

The three methods are briefly described in this section, and a discussion of their applicability to the Town of Parker is discussed. UDSWM is mostly used to combine and route the hydrographs generated using CUHP.

In general, the Rational Method is the most widely used and accepted technique for determining peak flows in urban areas for small basins. Within the constraints outlined in the MANUAL, use of the Rational Method provides a relatively simple but effective way to analyze storm runoff.

CUHP is somewhat more complicated than the Rational Method. It allows a manual computation of a runoff hydrograph which may be used for further hydraulic routing through channels and/or detention ponds. Historically, CUHP is best used in urban areas for which runoff coefficients have been derived. However, recent improvements by UDFCD include consideration for different soil types, thus CUHP is now more applicable to rural areas. The reader is referred to UDFCD for the latest version of CUHP.

UDSWM is a computer model that generates runoff hydrographs and routes and combines these hydrographs. UDSWM is a modified version of the Runoff Block of the Environmental Protection Agency's Storm Water Management Model (SWMM). It has been modified to be used in conjunction with CUHP. Table 5.2 herein provides guidance on selecting the appropriate method for a given project.

APPENDIX B3 - C-VALUES

Table 6-5. Runoff coefficients, *c*

Total or Effective % Impervious	NRCS Hydrologic Soil Group A						
	2-Year	5-Year	10-Year	25-Year	50-Year	100-Year	500-Year
2%	0.01	0.01	0.01	0.01	0.04	0.13	0.27
5%	0.02	0.02	0.02	0.03	0.07	0.15	0.29
10%	0.04	0.05	0.05	0.07	0.11	0.19	0.32
15%	0.07	0.08	0.08	0.1	0.15	0.23	0.35
20%	0.1	0.11	0.12	0.14	0.2	0.27	0.38
25%	0.14	0.15	0.16	0.19	0.24	0.3	0.42
30%	0.18	0.19	0.2	0.23	0.28	0.34	0.45
35%	0.21	0.23	0.24	0.27	0.32	0.38	0.48
40%	0.25	0.27	0.28	0.32	0.37	0.42	0.51
45%	0.3	0.31	0.33	0.36	0.41	0.46	0.54
50%	0.34	0.36	0.37	0.41	0.45	0.5	0.58
55%	0.39	0.4	0.42	0.45	0.49	0.54	0.61
60%	0.43	0.45	0.47	0.5	0.54	0.58	0.64
65%	0.48	0.5	0.51	0.54	0.58	0.62	0.67
70%	0.53	0.55	0.56	0.59	0.62	0.65	0.71
75%	0.58	0.6	0.61	0.64	0.66	0.69	0.74
80%	0.63	0.65	0.66	0.69	0.71	0.73	0.77
85%	0.68	0.7	0.71	0.74	0.75	0.77	0.8
90%	0.73	0.75	0.77	0.79	0.79	0.81	0.84
95%	0.79	0.81	0.82	0.83	0.84	0.85	0.87
100%	0.84	0.86	0.87	0.88	0.88	0.89	0.9
Total or Effective % Impervious	NRCS Hydrologic Soil Group B						
	2-Year	5-Year	10-Year	25-Year	50-Year	100-Year	500-Year
2%	0.01	0.01	0.07	0.26	0.34	0.44	0.54
5%	0.03	0.03	0.1	0.28	0.36	0.45	0.55
10%	0.06	0.07	0.14	0.31	0.38	0.47	0.57
15%	0.09	0.11	0.18	0.34	0.41	0.5	0.59
20%	0.13	0.15	0.22	0.38	0.44	0.52	0.61
25%	0.17	0.19	0.26	0.41	0.47	0.54	0.63
30%	0.2	0.23	0.3	0.44	0.49	0.57	0.65
35%	0.24	0.27	0.34	0.47	0.52	0.59	0.66
40%	0.29	0.32	0.38	0.5	0.55	0.61	0.68
45%	0.33	0.36	0.42	0.53	0.58	0.64	0.7
50%	0.37	0.4	0.46	0.56	0.61	0.66	0.72
55%	0.42	0.45	0.5	0.6	0.63	0.68	0.74
60%	0.46	0.49	0.54	0.63	0.66	0.71	0.76
65%	0.5	0.54	0.58	0.66	0.69	0.73	0.77
70%	0.55	0.58	0.62	0.69	0.72	0.75	0.79
75%	0.6	0.63	0.66	0.72	0.75	0.78	0.81
80%	0.64	0.67	0.7	0.75	0.77	0.8	0.83
85%	0.69	0.72	0.74	0.78	0.8	0.82	0.85
90%	0.74	0.76	0.78	0.81	0.83	0.84	0.87
95%	0.79	0.81	0.82	0.85	0.86	0.87	0.88
100%	0.84	0.86	0.86	0.88	0.89	0.89	0.9

NO.	REVISION	BY	DATE	APPR.

Kimley»Horn
 2020 KIMLEY-HORN AND ASSOCIATES, INC.
 4582 South Ulster Street, Suite 1500
 Denver, Colorado 80237 (303) 228-2300

DESIGNED BY: DLS
 DRAWN BY: ECZ
 CHECKED BY: DLS
 DATE: 03/11/20

PARKER & PINE MINOR DEVELOPMENT FILING NO. 1
 CONSTRUCTION DOCUMENTS
 PARKER, CO

PROJECT NO.
 096502001
 DRAWING NAME
 096502001ST_DET
 C6.3

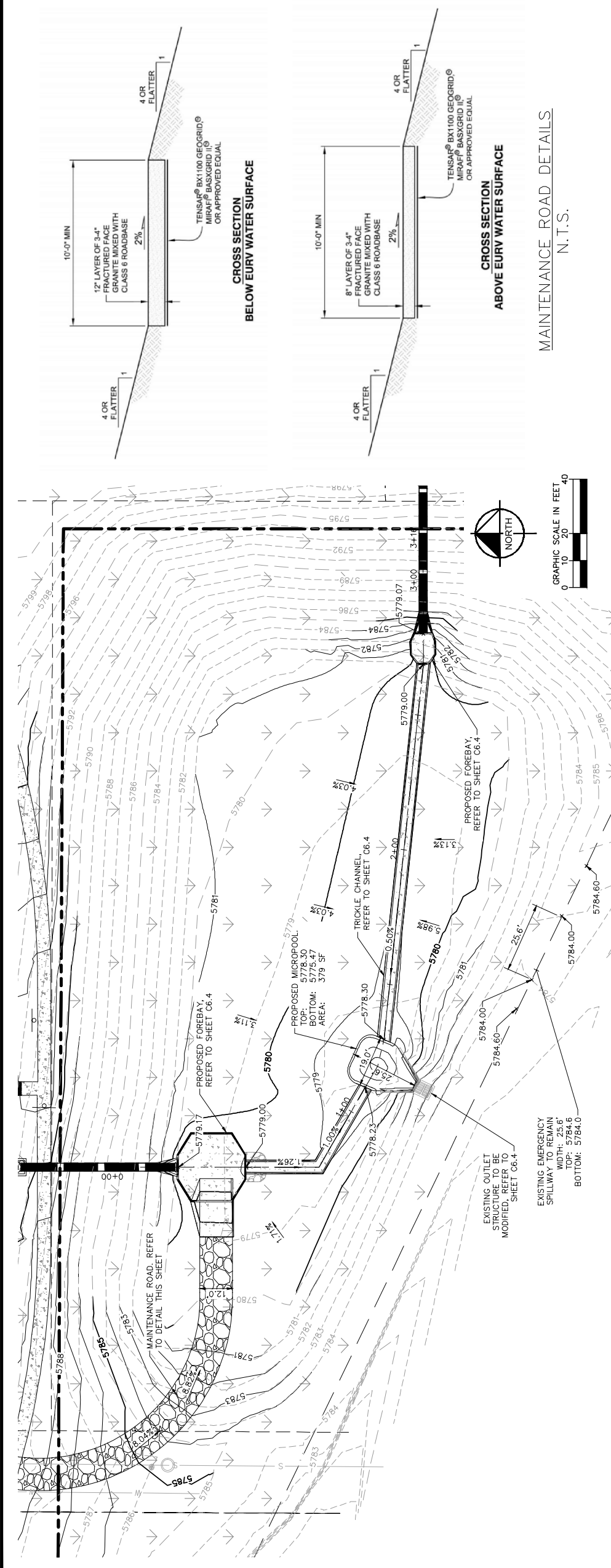

MAINTENANCE ROAD DETAILS
 N.T.S.

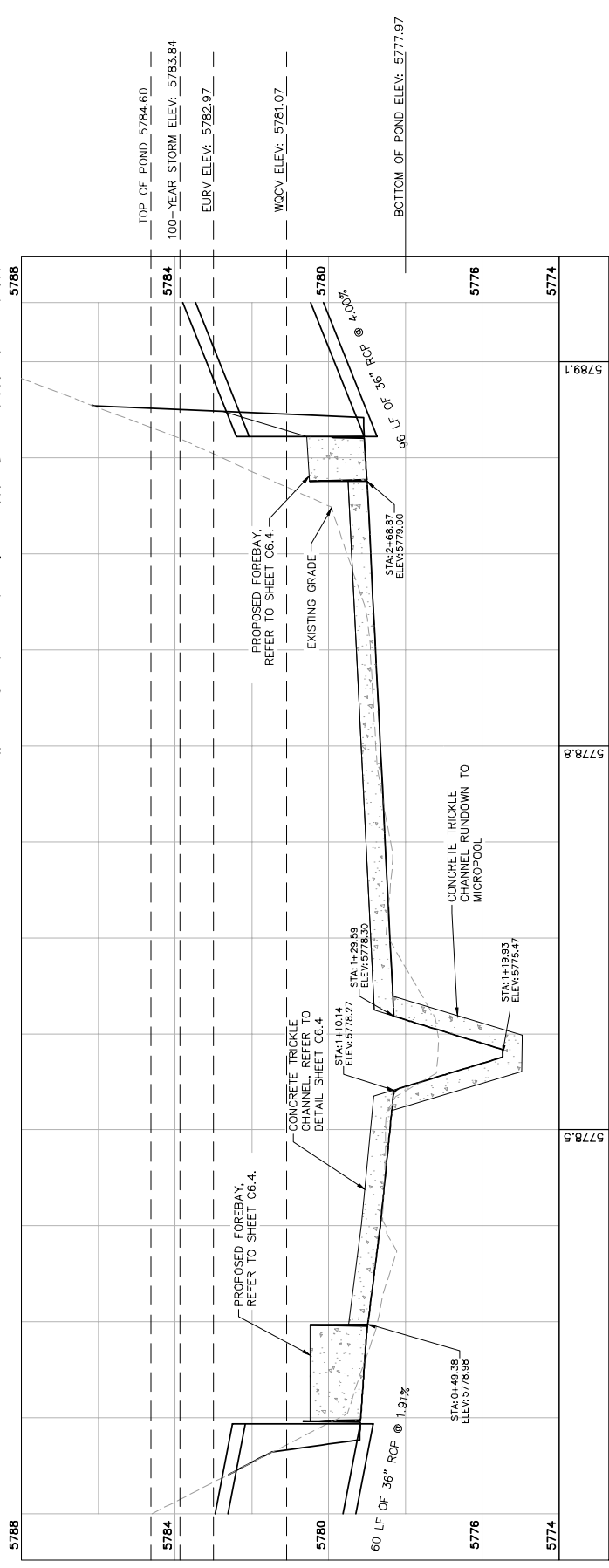
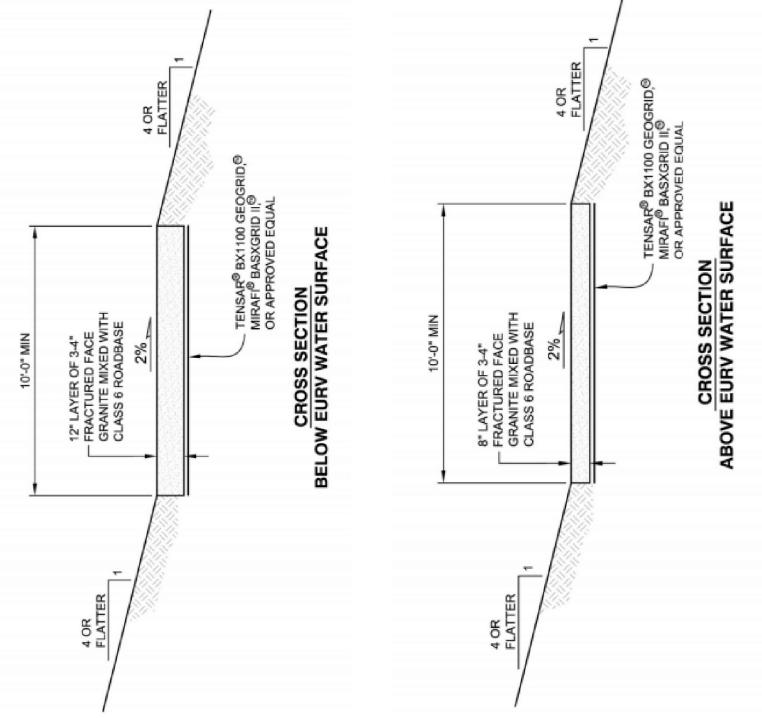

POND PROFILE
 HORIZONTAL SCALE: 1" = 20'
 VERTICAL SCALE: 1" = 2'

APPENDIX C - OVERALL DRAINAGE MAP

K:\DEN_Civil\096502001 - Mixed Use Parker Rd\CADD\PlanSheets\096502001DRM.dwg - Zentaris, Even 10/5/2019 10:57 AM
 THIS DOCUMENT, TOGETHER WITH THE CONCEPTS AND DESIGNS PRESENTED HEREIN, IS AN INSTRUMENT OF SERVICE AS DEFINED IN THE PROFESSIONAL ENGINEERING AND ARCHITECTURE ACT, AND SHALL BE WITHOUT LIABILITY TO KIMLEY-HORN AND ASSOCIATES, INC.

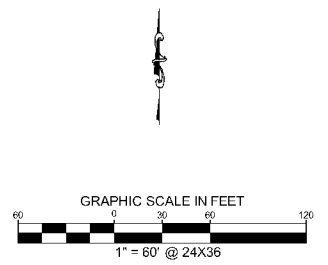
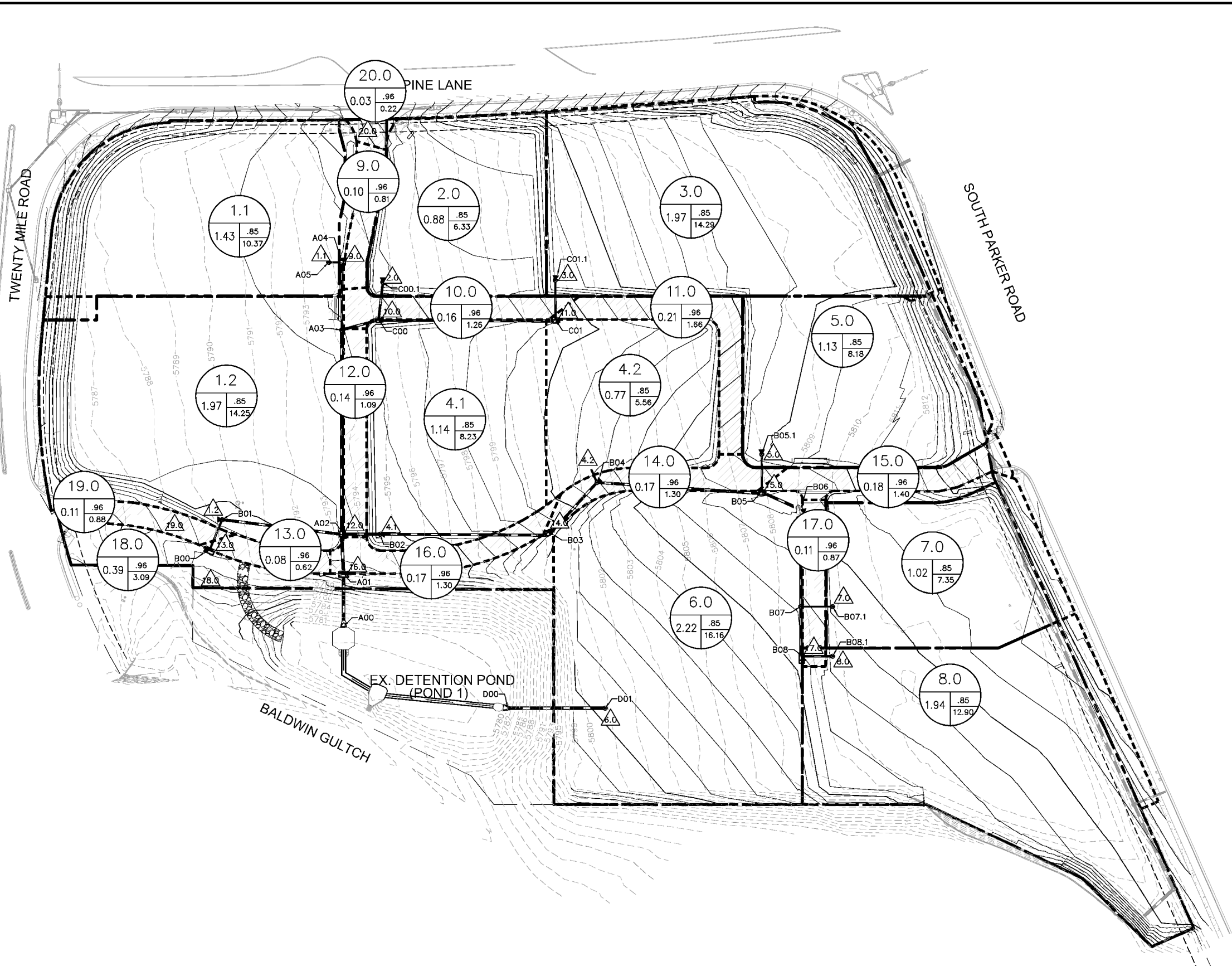

LEGEND

- | |
|-------|
| A |
| B C |
| D |

 A = BASIN DESIGNATION
- B = AREA (ACRES)
- C = BASIN IMPERVIOUSNESS
- D = 100YR DESIGN STORM RUNOFF (CFS)
- FLOW DIRECTION
- DRAINAGE BASIN BOUNDARY
- EXISTING PROPERTY LINE
- EXISTING CONTOUR
- PROPOSED CONTOUR
- EXISTING STORM SEWER
- PROPOSED STORM SEWER
- PROPOSED STORM INLET

NO.	REVISION	BY	DATE	APPR.

Kimley»Horn
 2019 KIMLEY-HORN AND ASSOCIATES, INC.
 1080 South U.S. Hwy. 1900
 Denver, Colorado 80237 (303) 728-3700

DESIGNED BY: DLS
 DRAWN BY: ECZ
 CHECKED BY: DLS
 DATE: 11/11/19

PARKER & PINE
 PARKER, CO
 CONSTRUCTION DOCUMENTS
PRELIMINARY DRAINAGE AREA MAP

PRELIMINARY
 FOR REVIEW ONLY
 NOT FOR
 CONSTRUCTION
Kimley»Horn
 Kimley-Horn and Associates, Inc.

PROJECT NO.
 096502001
 DRAWING NAME
 096502001DRM
DRAINAGE



APPENDIX D - RATIONAL METHOD CALCULATIONS, INLET CALCULATIONS

Rainfall Intensity

IDF - Intensity, Duration, Frequency Data

Time Intensity Frequency Tabulation

TIME	2 YR	5 YR	10 YR	100 YR
5	3.36	4.71	5.56	8.82
6	3.19	4.48	5.29	8.38
7	3.04	4.27	5.04	7.99
8	2.91	4.09	4.82	7.64
9	2.79	3.92	4.62	7.32
10	2.68	3.76	4.44	7.03
11	2.58	3.62	4.27	6.77
12	2.49	3.49	4.12	6.53
13	2.40	3.37	3.98	6.30
14	2.32	3.26	3.84	6.09
15	2.25	3.16	3.72	5.90
16	2.18	3.06	3.61	5.72
17	2.12	2.97	3.50	5.56
18	2.06	2.89	3.41	5.40
19	2.00	2.81	3.31	5.25
20	1.95	2.73	3.23	5.11
21	1.90	2.66	3.14	4.98
22	1.85	2.60	3.07	4.86
23	1.81	2.54	2.99	4.75
24	1.76	2.48	2.92	4.64
25	1.73	2.42	2.86	4.53
26	1.69	2.37	2.80	4.43
27	1.65	2.32	2.74	4.34
28	1.62	2.27	2.68	4.25
29	1.58	2.22	2.62	4.16
30	1.55	2.18	2.57	4.08
31	1.52	2.14	2.52	4.00
32	1.49	2.10	2.48	3.93
33	1.47	2.06	2.43	3.85
34	1.44	2.02	2.39	3.78
35	1.42	1.99	2.35	3.72
36	1.39	1.95	2.31	3.66
37	1.37	1.92	2.27	3.59
38	1.35	1.89	2.23	3.53
39	1.32	1.86	2.19	3.48
40	1.30	1.83	2.16	3.42
41	1.28	1.80	2.13	3.37
42	1.26	1.77	2.09	3.32
43	1.25	1.75	2.06	3.27
44	1.23	1.72	2.03	3.22
45	1.21	1.70	2.00	3.18
46	1.19	1.67	1.98	3.13
47	1.18	1.65	1.95	3.09
48	1.16	1.63	1.92	3.05
49	1.14	1.61	1.90	3.01
50	1.13	1.59	1.87	2.97
51	1.11	1.57	1.85	2.93
52	1.10	1.55	1.82	2.89
53	1.09	1.53	1.80	2.85
54	1.07	1.51	1.78	2.82
55	1.06	1.49	1.76	2.79
56	1.05	1.47	1.74	2.75
57	1.04	1.45	1.72	2.72
58	1.02	1.44	1.70	2.69
59	1.01	1.42	1.68	2.66
60	1.00	1.40	1.66	2.63

Note:
Intensity values utilized as published within the Town of Parker
Storm Drainage Criteria Manual, Table 5.1

Time Intensity Frequency Tabulation

TIME	2 YR	5 YR	10 YR	100 YR
5	3.36	4.71	5.56	8.82
6	3.19	4.48	5.29	8.38
7	3.04	4.27	5.04	7.99
8	2.91	4.09	4.82	7.64
9	2.79	3.92	4.62	7.32
10	2.68	3.76	4.44	7.03
11	2.58	3.62	4.27	6.77
12	2.49	3.49	4.12	6.53
13	2.40	3.37	3.98	6.30
14	2.32	3.26	3.84	6.09
15	2.25	3.16	3.72	5.90
16	2.18	3.06	3.61	5.72
17	2.12	2.97	3.50	5.56
18	2.06	2.89	3.41	5.40
19	2.00	2.81	3.31	5.25
20	1.95	2.73	3.23	5.11
21	1.90	2.66	3.14	4.98
22	1.85	2.60	3.07	4.86
23	1.81	2.54	2.99	4.75
24	1.76	2.48	2.92	4.64
25	1.73	2.42	2.86	4.53
26	1.69	2.37	2.80	4.43
27	1.65	2.32	2.74	4.34
28	1.62	2.27	2.68	4.25
29	1.58	2.22	2.62	4.16
30	1.55	2.18	2.57	4.08
31	1.52	2.14	2.52	4.00
32	1.49	2.10	2.48	3.93
33	1.47	2.06	2.43	3.85
34	1.44	2.02	2.39	3.78
35	1.42	1.99	2.35	3.72
36	1.39	1.95	2.31	3.66
37	1.37	1.92	2.27	3.59
38	1.35	1.89	2.23	3.53
39	1.32	1.86	2.19	3.48
40	1.30	1.83	2.16	3.42
41	1.28	1.80	2.13	3.37
42	1.26	1.77	2.09	3.32
43	1.25	1.75	2.06	3.27
44	1.23	1.72	2.03	3.22
45	1.21	1.70	2.00	3.18
46	1.19	1.67	1.98	3.13
47	1.18	1.65	1.95	3.09
48	1.16	1.63	1.92	3.05
49	1.14	1.61	1.90	3.01
50	1.13	1.59	1.87	2.97
51	1.11	1.57	1.85	2.93
52	1.10	1.55	1.82	2.89
53	1.09	1.53	1.80	2.85
54	1.07	1.51	1.78	2.82
55	1.06	1.49	1.76	2.79
56	1.05	1.47	1.74	2.75
57	1.04	1.45	1.72	2.72
58	1.02	1.44	1.70	2.69
59	1.01	1.42	1.68	2.66
60	1.00	1.40	1.66	2.63

BASIN IMPERVIOUSNESS AND RUNOFF COEFFICIENT

Landuse	I	C ₂	C ₅	C ₁₀	C ₁₀₀
Landscape	2%	0.01	0.01	0.07	0.44
Roof	90%	0.74	0.76	0.78	0.84
Streets/Drives and Walks	100%	0.84	0.86	0.86	0.89

All Basins

Basin Designation	A _{TOTAL} (AC)	A _{TOTAL} (SF)	A _{LANDSCAPE} (SF)	A _{ROOF} (SF)	A _{STREETS/DRIVES & WALKS} (SF)	I _{WEIGHTED}	C ₂	C ₅	C ₁₀₀	SIGN POI	INLET
1.1	1.43	62,381	9,500	0	52,881	85%	0.71	0.73	0.82		
1.2	1.97	85,635	13,000	0	72,635	85%	0.71	0.73	0.82		
2.0	0.88	38,143	6,000	0	32,143	85%	0.71	0.73	0.82		
3.0	1.97	85,881	13,000	0	72,881	85%	0.71	0.73	0.82		
4.1	1.14	49,452	7,500	0	41,952	85%	0.71	0.73	0.82		
4.2	0.77	33,396	5,000	0	28,396	85%	0.72	0.73	0.82		
5.0	1.13	49,201	7,500	0	41,701	85%	0.71	0.73	0.82		
6.0	2.22	96,743	15,000	0	81,743	85%	0.71	0.73	0.82		
7.0	1.02	44,356	7,000	0	37,356	85%	0.71	0.73	0.82		
8.0	1.94	84,345	13,000	0	71,345	85%	0.71	0.73	0.82		
9.0	0.10	4,470	0	0	4,470	100%	0.84	0.86	0.89		
10.0	0.16	6,975	0	0	6,975	100%	0.84	0.86	0.89		
11.0	0.21	9,219	0	0	9,219	100%	0.84	0.86	0.89		
12.0	0.14	6,073	0	0	6,073	100%	0.84	0.86	0.89		
13.0	0.08	3,465	0	0	3,465	100%	0.84	0.86	0.89		
14.0	0.17	7,207	0	0	7,207	100%	0.84	0.86	0.89		
15.0	0.18	7,746	0	0	7,746	100%	0.84	0.86	0.89		
16.0	0.17	7,231	0	0	7,231	100%	0.84	0.86	0.89		
17.0	0.11	4,854	0	0	4,854	100%	0.84	0.86	0.89		
18.0	0.39	17,130	0	0	17,130	100%	0.84	0.86	0.89		
19.0	0.11	4,871	0	0	4,871	100%	0.84	0.86	0.89		
20.0	0.03	1,228	0	0	1,228	100%	0.84	0.86	0.89		
	16.30	710,001	96,500	-	613,501	87%	0.73	0.74	0.83		

Detained Basins

Basin Designation	A _{TOTAL} (AC)	A _{TOTAL} (SF)	A _{LANDSCAPE} (SF)	A _{ROOF} (SF)	A _{DRIVES & WALKS} (SF)	I _{WEIGHTED}	C ₂	C ₅	C ₁₀₀
1	1.43	62,381	9,500	0	52,881	85%	0.71	0.73	0.82
2	1.97	85,635	13,000	0	72,635	85%	0.71	0.73	0.82
3	0.88	38,143	6,000	0	32,143	85%	0.71	0.73	0.82
4	1.97	85,881	13,000	0	72,881	85%	0.71	0.73	0.82
5	1.14	49,452	7,500	0	41,952	85%	0.71	0.73	0.82
6	0.77	33,396	5,000	0	28,396	85%	0.72	0.73	0.82
7	1.13	49,201	7,500	0	41,701	85%	0.71	0.73	0.82
8	2.22	96,743	15,000	0	81,743	85%	0.71	0.73	0.82
9	1.02	44,356	7,000	0	37,356	85%	0.71	0.73	0.82
10	1.94	84,345	13,000	0	71,345	85%	0.71	0.73	0.82
11	0.10	4,470	0	0	4,470	100%	0.84	0.86	0.89
12	0.16	6,975	0	0	6,975	100%	0.84	0.86	0.89
13	0.21	9,219	0	0	9,219	100%	0.84	0.86	0.89
14	0.14	6,073	0	0	6,073	100%	0.84	0.86	0.89
15	0.08	3,465	0	0	3,465	100%	0.84	0.86	0.89
16	0.17	7,207	0	0	7,207	100%	0.84	0.86	0.89
17	0.18	7,746	0	0	7,746	100%	0.84	0.86	0.89
18	0.39	17,130	0	0	17,130	100%	0.84	0.86	0.89
	15.88	691,818	96,500	-	595,318	86%	0.72	0.74	0.83

Undetained Basins

Basin Designation	A _{TOTAL} (AC)	A _{TOTAL} (SF)	A _{LANDSCAPE} (SF)	A _{ROOF} (SF)	A _{DRIVES & WALKS} (SF)	I _{WEIGHTED}	C ₂	C ₅	C ₁₀₀
19	0.11	4,871	0	0	4,871	100%	0.84	0.86	0.89
20	0.03	1,228	0	0	1,228	100%	0.84	0.86	0.89
	0.14	6,099	-	-	6,099	100%	0.84	0.86	0.89

Time of Concentration

DESIGN POINT	SUB-BASIN DATA						INITIAL / OVERLAND TIME T(i)			TRAVEL TIME T(t)					T(c) CHECK (URBANIZED BASINS)			FINAL T(c) (MIN)
	DRAIN BASIN	AREA SF	AREA AC	NRCS Soil Type	I %	C(5)	Length FT	Slope %	T(i) MIN	Length FT	Slope %	Coefficient	Velocity FPS	T(t) MIN	T(c) (MIN)	TOTAL LENGTH	L/180+10	
1.1	1.1	62,381	1.43	B	85%	0.73	45	2.0%	3.6	-	-	20	0.0	0.0	5.0	45	10.3	5.0
1.2	1.2	85,635	1.97	B	85%	0.73	41	21.0%	1.6	450	3.1%	15	2.6	2.8	5.0	491	12.7	5.0
2.0	2.0	38,143	0.88	B	85%	0.73	40	5.6%	2.4	60	3.3%	20	3.6	0.3	5.0	100	10.6	5.0
3.0	3.0	85,881	1.97	B	85%	0.73	69	4.3%	3.5	97	1.3%	20	2.2	0.7	5.0	166	10.9	5.0
4.1	4.1	49,452	1.14	B	85%	0.73	170	7.0%	4.6	50	2.7%	20	3.3	0.3	5.0	220	11.2	5.0
4.2	4.2	33,396	0.77	B	85%	0.73	93	9.2%	3.1	163	3.7%	20	3.8	0.7	5.0	256	11.4	5.0
5.0	5.0	49,201	1.13	B	85%	0.73	0	0.0%		230	1.0%	21	2.1	1.8	5.0	230	11.3	5.0
6.0	6.0	96,743	2.22	B	85%	0.73	50	2.0%	3.8	150	3.0%	20	3.5	0.7	5.0	200	11.1	5.0
7.0	7.0	44,356	1.02	B	85%	0.73	35	1.5%	3.5	105	2.0%	20	2.8	0.6	5.0	140	10.8	5.0
8.0	8.0	84,345	1.94	B	85%	0.73	100	1.0%	6.8	10	15.0%	20	7.7	0.0	6.8	110	10.6	6.8
9.0	9.0	4,470	0.10	B	100%	0.86	101	101.0%	0.9	11	115.0%	21	22.5	0.0	5.0	112	10.6	5.0
10.0	10.0	6,975	0.16	B	100%	0.86	75	5.0%	2.2	130	2.5%	20	3.2	0.7	5.0	205	11.1	5.0
11.0	11.0	9,219	0.21	B	100%	0.86	45	4.3%	1.8	500	3.6%	20	3.8	2.2	5.0	545	13.0	5.0
12.0	12.0	6,073	0.14	B	100%	0.86	100	1.0%	4.4	10	15.0%	20	7.7	0.0	5.0	110	10.6	5.0
13.0	13.0	3,465	0.08	B	100%	0.86	101	101.0%	0.9	11	115.0%	21	22.5	0.0	5.0	112	10.6	5.0
14.0	14.0	7,207	0.17	B	100%	0.86	63	2.0%	2.8	98	0.7%	20	1.7	1.0	5.0	161	10.9	5.0
15.0	15.0	7,746	0.18	B	100%	0.86	35	17.0%	1.0	72	1.2%	20	2.2	0.5	5.0	107	10.6	5.0
16.0	16.0	7,231	0.17	B	100%	0.86	90	15.0%	1.7	50	3.0%	20	3.5	0.2	5.0	140	10.8	5.0
17.0	17.0	4,854	0.11	B	100%	0.86	90	15.0%	1.7	51	3.0%	20	3.5	0.2	5.0	141	10.8	5.0
18.0	18.0	17,130	0.39	B	100%	0.86	90	15.0%	1.7	52	3.0%	20	3.5	0.3	5.0	142	10.8	5.0
19.0	19.0	4,871	0.11	B	100%	0.86	90	15.0%	1.7	53	3.0%	20	3.5	0.3	5.0	143	10.8	5.0
20.0	20.0	1,228	0.03	B	100%	0.86	90	15.0%	1.7	54	3.0%	20	3.5	0.3	5.0	144	10.8	5.0

Watercourse Coefficient

Forest & Meadow	2.5
Fallow or Cultivation	5.0
Short Grass Pasture & Lawns	7.0
Nearly Bare Ground	10.0
Grassed Waterway	15.0
Paved Area and Shallow Gutter	20.0

CIA Runoff Calculations

2-Year Design Storm Runoff Calculations

(Rational Method Procedure)

BASIN INFORMATION				DIRECT RUNOFF				TOTAL RUNOFF				REMARKS
DESIGN POINT	DRAIN BASIN	AREA Ac	RUNOFF COEFF	T(c) Min	C x A	I In/Hr	Q CFS	T(c) Min	SUM C x A	I In/Hr	Q CFS	
1	1.1	1.43	0.71	5.0	1.02	3.36	3.43	5.0	1.02	3.4	3.43	
1	1.2	1.97	0.71	5.0	1.40	3.36	4.71	5.0	2.4	3.4	8.14	
1	2.0	0.88	0.71	5.0	0.62	3.36	2.09	5.0	3.0	3.4	10.23	
1	3.0	1.97	0.71	5.0	1.41	3.36	4.73	5.0	4.5	3.4	14.96	
1	4.1	1.14	0.71	5.0	0.81	3.36	2.72	5.0	5.3	3.4	17.68	
1	4.2	0.77	0.72	5.0	0.549	3.36	1.84	5.0	5.8	3.4	19.53	
1	5.0	1.13	0.71	5.0	0.806	3.36	2.71	5.0	6.6	3.4	22.23	
1	6.0	2.22	0.71	5.0	1.580	3.36	5.30	5.0	8.2	3.4	27.54	
1	7.0	1.02	0.71	5.0	0.722	3.36	2.42	5.0	8.9	3.4	29.96	
1	8.0	1.94	0.71	6.8	1.379	3.09	4.26	5.0	10.3	3.4	34.59	
1	9.0	0.10	0.84	5.0	0.086	3.36	0.29	5.0	10.4	3.4	34.88	
1	10.0	0.16	0.84	5.0	0.135	3.36	0.45	5.0	10.5	3.4	35.33	
1	11.0	0.21	0.84	5.0	0.178	3.36	0.60	5.0	10.7	3.4	35.93	
1	12.0	0.14	0.84	5.0	0.117	3.36	0.39	5.0	10.8	3.4	36.32	
1	13.0	0.08	0.84	5.0	0.067	3.36	0.22	5.0	10.9	3.4	36.55	
1	14.0	0.17	0.84	5.0	0.139	3.36	0.47	5.0	11.0	3.4	37.01	
1	15.0	0.18	0.84	5.0	0.149	3.36	0.50	5.0	11.2	3.4	37.51	
1	16.0	0.17	0.84	5.0	0.139	3.36	0.47	5.0	11.3	3.4	37.98	
1	17.0	0.11	0.84	5.0	0.094	3.36	0.31	5.0	11.4	3.4	38.30	
1	18.0	0.39	0.84	5.0	0.330	3.36	1.11	5.0	11.7	3.4	39.41	
1	19.0	0.11	0.84	5.0	0.094	3.36	0.32	5.0	11.8	3.4	39.72	
1	20.0	0.03	0.84	5.0	0.024	3.36	0.08	5.0	11.9	3.4	39.80	

5-Year Design Storm Runoff Calculations
 (Rational Method Procedure)

BASIN INFORMATION				DIRECT RUNOFF				TOTAL RUNOFF				REMARKS
DESIGN POINT	DRAIN BASIN	AREA Ac	RUNOFF COEFF	T(c) Min	C x A	I In/Hr	Q CFS	T(c) Min	SUM C x A	I In/Hr	Q CFS	
1	1.1	1.43	0.73	5.0	1.05	4.71	4.93	5.0	1.05	4.7	4.93	
1	1.2	1.97	0.73	5.0	1.44	4.71	6.77	5.0	2.5	4.7	11.71	
1	2.0	0.88	0.73	5.0	0.64	4.71	3.00	5.0	3.1	4.7	14.71	
1	3.0	1.97	0.73	5.0	1.44	4.71	6.80	5.0	4.6	4.7	21.50	
1	4.1	1.14	0.73	5.0	0.83	4.71	3.91	5.0	5.4	4.7	25.42	
1	4.2	0.77	0.73	5.0	0.56	4.71	2.65	5.0	6.0	4.7	28.07	
1	5.0	1.13	0.73	5.0	0.83	4.71	3.89	5.0	6.8	4.7	31.96	
1	6.0	2.22	0.73	5.0	1.62	4.71	7.62	5.0	8.4	4.7	39.58	
1	7.0	1.02	0.73	5.0	0.74	4.71	3.48	5.0	9.1	4.7	43.06	
1	8.0	1.94	0.73	6.8	1.41	4.34	6.13	5.0	10.5	4.7	49.72	
1	9.0	0.10	0.86	5.0	0.09	4.71	0.42	5.0	10.6	4.7	50.14	
1	10.0	0.16	0.86	5.0	0.14	4.71	0.65	5.0	10.8	4.7	50.79	
1	11.0	0.21	0.86	5.0	0.18	4.71	0.86	5.0	11.0	4.7	51.64	
1	12.0	0.14	0.86	5.0	0.12	4.71	0.57	5.0	11.1	4.7	52.21	
1	13.0	0.08	0.86	5.0	0.07	4.71	0.32	5.0	11.1	4.7	52.53	
1	14.0	0.17	0.86	5.0	0.14	4.71	0.67	5.0	11.3	4.7	53.20	
1	15.0	0.18	0.86	5.0	0.15	4.71	0.72	5.0	11.4	4.7	53.92	
1	16.0	0.17	0.86	5.0	0.14	4.71	0.67	5.0	11.6	4.7	54.60	
1	17.0	0.11	0.86	5.0	0.10	4.71	0.45	5.0	11.7	4.7	55.05	
1	18.0	0.39	0.86	5.0	0.34	4.71	1.59	5.0	12.0	4.7	56.64	
1	19.0	0.11	0.86	5.0	0.10	4.71	0.45	5.0	12.1	4.7	57.10	
1	20.0	0.03	0.86	5.0	0.02	4.71	0.11	5.0	12.1	4.7	57.21	

100-Year Design Storm Runoff Calculations
(Rational Method Procedure)

BASIN INFORMATION				DIRECT RUNOFF				TOTAL RUNOFF				REMARKS
DESIGN POINT	DRAIN BASIN	AREA Ac	RUNOFF COEFF	T(c) Min	C x A	I In/Hr	Q CFS	T(c) Min	SUM C x A	I In/Hr	Q CFS	
1	1.1	1.43	0.82	5.0	1.18	8.82	10.37	5.0	1.18	8.8	10.37	
1	1.2	1.97	0.82	5.0	1.62	8.82	14.25	5.0	2.8	8.8	24.62	
1	2.0	0.88	0.82	5.0	0.72	8.82	6.33	5.0	3.5	8.8	30.95	
1	3.0	1.97	0.82	5.0	1.62	8.82	14.29	5.0	5.1	8.8	45.24	
1	4.1	1.14	0.82	5.0	0.93	8.82	8.23	5.0	6.1	8.8	53.46	
1	4.2	0.77	0.82	5.0	0.631	8.82	5.56	5.0	6.7	8.8	59.03	
1	5.0	1.13	0.82	5.0	0.928	8.82	8.18	5.0	7.6	8.8	67.21	
1	6.0	2.22	0.82	5.0	1.822	8.82	16.06	5.0	9.4	8.8	83.27	
1	7.0	1.02	0.82	5.0	0.834	8.82	7.35	5.0	10.3	8.8	90.63	
1	8.0	1.94	0.82	6.8	1.589	8.12	12.90	5.0	11.9	8.8	104.64	
1	9.0	0.10	0.89	5.0	0.091	8.82	0.81	5.0	12.0	8.8	105.44	
1	10.0	0.16	0.89	5.0	0.143	8.82	1.26	5.0	12.1	8.8	106.70	
1	11.0	0.21	0.89	5.0	0.188	8.82	1.66	5.0	12.3	8.8	108.36	
1	12.0	0.14	0.89	5.0	0.124	8.82	1.09	5.0	12.4	8.8	109.46	
1	13.0	0.08	0.89	5.0	0.071	8.82	0.62	5.0	12.5	8.8	110.08	
1	14.0	0.17	0.89	5.0	0.147	8.82	1.30	5.0	12.6	8.8	111.38	
1	15.0	0.18	0.89	5.0	0.158	8.82	1.40	5.0	12.8	8.8	112.78	
1	16.0	0.17	0.89	5.0	0.148	8.82	1.30	5.0	12.9	8.8	114.08	
1	17.0	0.11	0.89	5.0	0.099	8.82	0.87	5.0	13.0	8.8	114.95	
1	18.0	0.39	0.89	5.0	0.350	8.82	3.09	5.0	13.4	8.8	118.04	
1	19.0	0.11	0.89	5.0	0.100	8.82	0.88	5.0	13.5	8.8	118.92	
1	20.0	0.03	0.89	5.0	0.025	8.82	0.22	5.0	13.5	8.8	119.14	

DETENTION BASIN STAGE-STORAGE TABLE BUILDER

UD-Detention, Version 3.07 (February 2017)

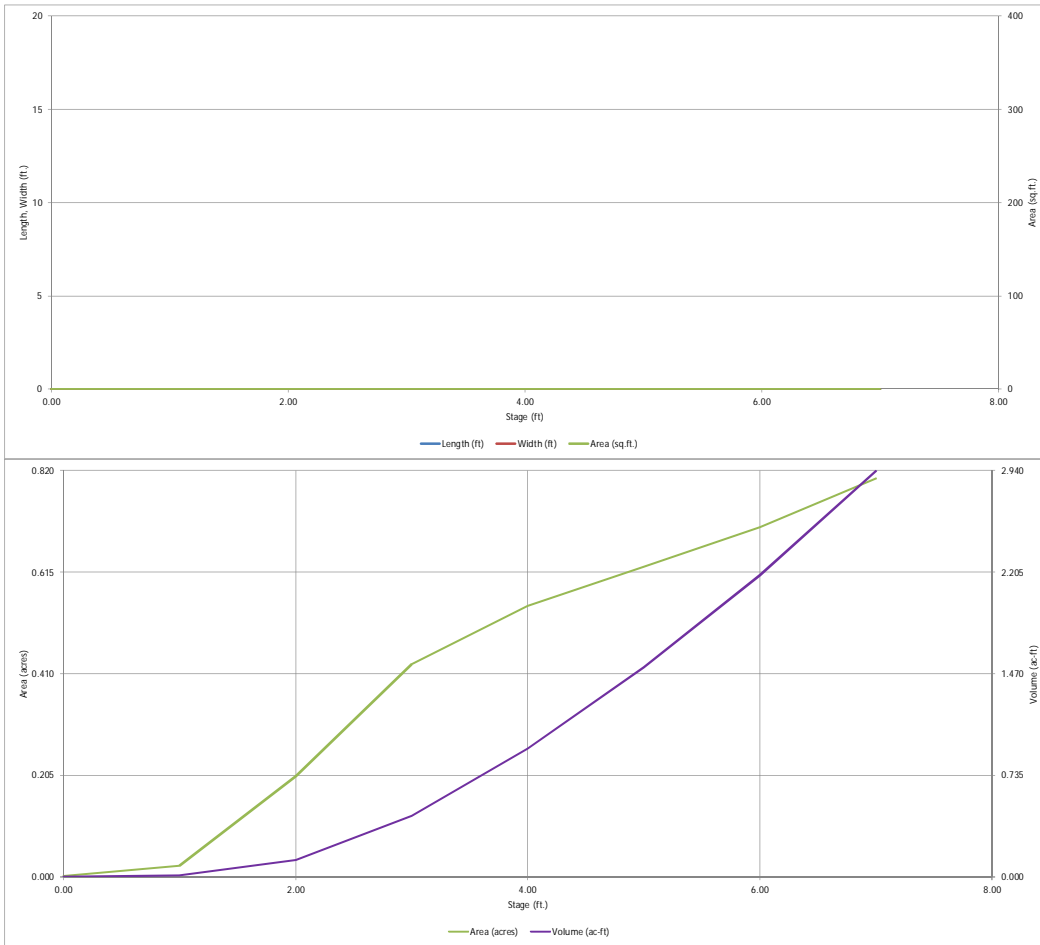

Detention Basin Outlet Structure Design

UD-Detention, Version 3.07 (February 2017)

Project: _____

Basin ID: _____

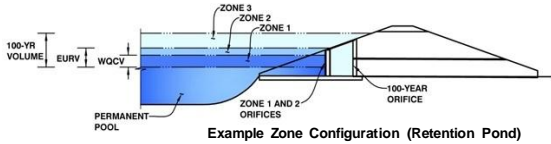

	Stage (ft)	Zone Volume (ac-ft)	Outlet Type
Zone 1 (WQCV)	3.10	0.481	Orifice Plate
Zone 2 (EURV)	5.00	1.031	Circular Orifice
Zone 3 (100-year)	5.87	0.575	Weir&Pipe (Rect.)
		2.087	Total

User Input: Orifice at Underdrain Outlet (typically used to drain WQCV in a Filtration BMP)

Underdrain Orifice Invert Depth = ft (distance below the filtration media surface)
 Underdrain Orifice Diameter = inches

Calculated Parameters for Underdrain

Underdrain Orifice Area = ft²
 Underdrain Orifice Centroid = feet

User Input: Orifice Plate with one or more orifices or Elliptical Slot Weir (typically used to drain WQCV and/or EURV in a sedimentation BMP)

Invert of Lowest Orifice = ft (relative to basin bottom at Stage = 0 ft)
 Depth at top of Zone using Orifice Plate = ft (relative to basin bottom at Stage = 0 ft)
 Orifice Plate: Orifice Vertical Spacing = inches
 Orifice Plate: Orifice Area per Row = sq. inches (diameter = 1-3/8 inches)

Calculated Parameters for Plate

WQ Orifice Area per Row = ft²
 Elliptical Half-Width = feet
 Elliptical Slot Centroid = feet
 Elliptical Slot Area = ft²

User Input: Stage and Total Area of Each Orifice Row (numbered from lowest to highest)

	Row 1 (required)	Row 2 (optional)	Row 3 (optional)	Row 4 (optional)	Row 5 (optional)	Row 6 (optional)	Row 7 (optional)	Row 8 (optional)
Stage of Orifice Centroid (ft)	0.00	1.03	2.07					
Orifice Area (sq. inches)	1.54	1.54	1.54					
	Row 9 (optional)	Row 10 (optional)	Row 11 (optional)	Row 12 (optional)	Row 13 (optional)	Row 14 (optional)	Row 15 (optional)	Row 16 (optional)
Stage of Orifice Centroid (ft)								
Orifice Area (sq. inches)								

User Input: Vertical Orifice (Circular or Rectangular)

Invert of Vertical Orifice = ft (relative to basin bottom at Stage = 0 ft)
 Depth at top of Zone using Vertical Orifice = ft (relative to basin bottom at Stage = 0 ft)
 Vertical Orifice Diameter = inches

Calculated Parameters for Vertical Orifice

Vertical Orifice Area = ft²
 Vertical Orifice Centroid = feet

User Input: Overflow Weir (Dropbox) and Grate (Flat or Sloped)

Overflow Weir Front Edge Height, Ho = ft (relative to basin bottom at Stage = 0 ft)
 Overflow Weir Front Edge Length = feet
 Overflow Weir Slope = H:V (enter zero for flat grate)
 Horiz. Length of Weir Sides = feet
 Overflow Grate Open Area % = % , grate open area/total area
 Debris Clogging % = %

Calculated Parameters for Overflow Weir

Height of Grate Upper Edge, H₁ = feet
 Over Flow Weir Slope Length = feet
 Grate Open Area / 100-yr Orifice Area = should be ≥ 4
 Overflow Grate Open Area w/o Debris = ft²
 Overflow Grate Open Area w/ Debris = ft²

User Input: Outlet Pipe w/ Flow Restriction Plate (Circular Orifice, Restrictor Plate, or Rectangular Orifice)

Depth to Invert of Outlet Pipe = ft (distance below basin bottom at Stage = 0 ft)
 Rectangular Orifice Width = inches
 Rectangular Orifice Height = inches

Calculated Parameters for Outlet Pipe w/ Flow Restriction Plate

Outlet Orifice Area = ft²
 Outlet Orifice Centroid = feet
 Half-Central Angle of Restrictor Plate on Pipe = radians

User Input: Emergency Spillway (Rectangular or Trapezoidal)

Spillway Invert Stage = ft (relative to basin bottom at Stage = 0 ft)
 Spillway Crest Length = feet
 Spillway End Slopes = H:V
 Freeboard above Max Water Surface = feet

Calculated Parameters for Spillway

Spillway Design Flow Depth = feet
 Stage at Top of Freeboard = feet
 Basin Area at Top of Freeboard = acres

Routed Hydrograph Results

	WQCV	EURV	2 Year	5 Year	10 Year	25 Year	50 Year	100 Year	500 Year
Design Storm Return Period									
One-Hour Rainfall Depth (in)	0.53	1.07	0.83	1.11	1.36	1.72	2.01	2.32	3.10
Calculated Runoff Volume (acre-ft)	0.481	1.512	0.898	1.244	1.602	2.128	2.497	2.964	4.084
OPTIONAL Override Runoff Volume (acre-ft)									
Inflow Hydrograph Volume (acre-ft)	0.480	1.511	0.898	1.243	1.601	2.127	2.497	2.963	4.084
Predevelopment Unit Peak Flow, q (cfs/acre)	0.00	0.00	0.01	0.02	0.18	0.65	0.93	1.28	2.02
Predevelopment Peak Q (cfs)	0.0	0.0	0.2	0.3	2.9	10.3	14.8	20.4	32.3
Peak Inflow Q (cfs)	8.9	27.5	16.5	22.7	29.2	38.6	45.2	53.5	73.4
Peak Outflow Q (cfs)	1.7	2.2	1.9	2.1	2.3	5.8	10.2	12.3	34.6
Ratio Peak Outflow to Predevelopment Q	N/A	N/A	N/A	7.6	0.8	0.6	0.7	0.6	1.1
Structure Controlling Flow	Vertical Orifice 1	Vertical Orifice 1	Vertical Orifice 1	Vertical Orifice 1	Vertical Orifice 1	Overflow Grate 1	Overflow Grate 1	Outlet Plate 1	Spillway
Max Velocity through Grate 1 (fps)	N/A	N/A	N/A	N/A	N/A	0.2	0.5	0.6	0.7
Max Velocity through Grate 2 (fps)	N/A	N/A	N/A	N/A	N/A	N/A	N/A	N/A	N/A
Time to Drain 97% of Inflow Volume (hours)	4	10	7	9	10	11	12	12	11
Time to Drain 99% of Inflow Volume (hours)	4	10	7	9	11	12	12	12	12
Maximum Ponding Depth (ft)	2.68	4.54	3.52	4.11	4.67	5.29	5.57	5.94	6.41
Area at Maximum Ponding Depth (acres)	0.36	0.59	0.49	0.55	0.60	0.65	0.67	0.70	0.75
Maximum Volume Stored (acre-ft)	0.316	1.230	0.675	0.984	1.313	1.693	1.885	2.138	2.478

Detention Basin Outlet Structure Design

UD-Detention, Version 3.07 (February 2017)

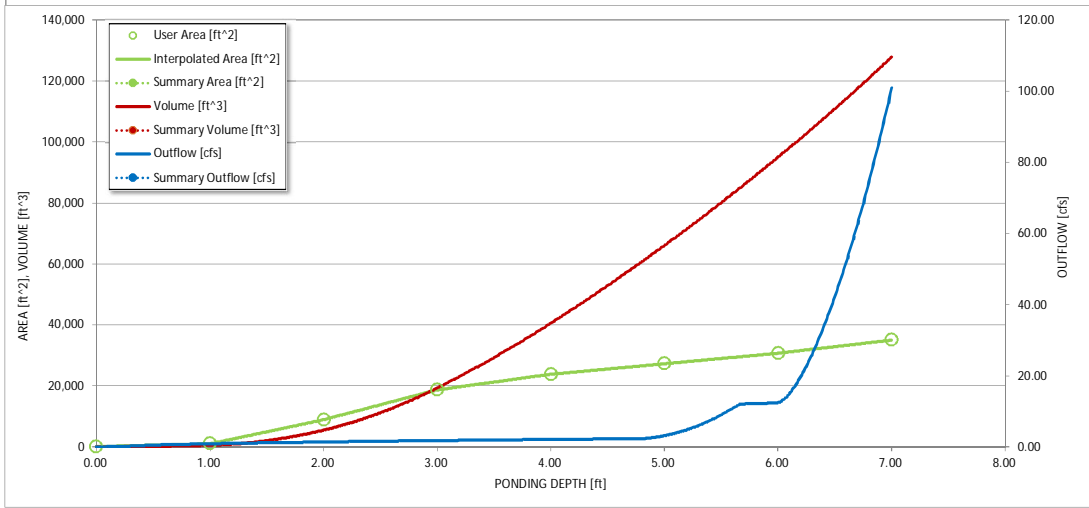
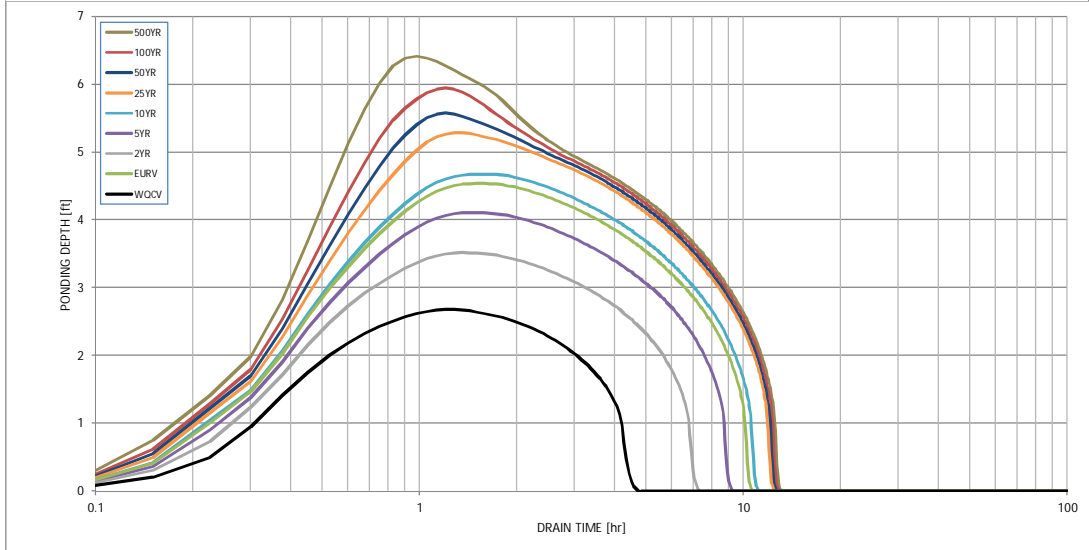
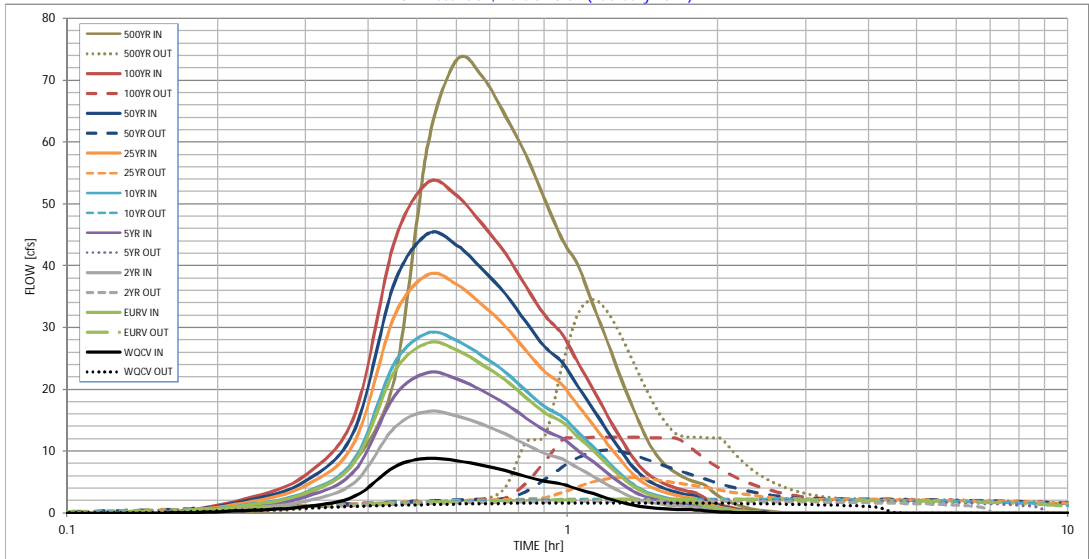

S-A-V-D Chart Axis Override	X-axis	Left Y-Axis	Right Y-Axis
minimum bound			
maximum bound			

ALLOWABLE CAPACITY FOR ONE-HALF OF STREET (Minor & Major Storm)

(Based on Regulated Criteria for Maximum Allowable Flow Depth and Spread)

Project: **Parker & Pine Retail**
 Inlet ID: **Inlet A04**

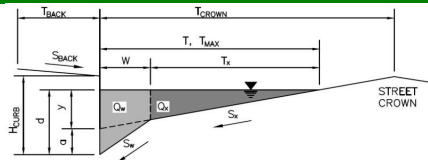

Gutter Geometry (Enter data in the blue cells)

Maximum Allowable Width for Spread Behind Curb
 Side Slope Behind Curb (leave blank for no conveyance credit behind curb)
 Manning's Roughness Behind Curb (typically between 0.012 and 0.020)

$T_{BACK} =$ ft
 $S_{BACK} =$ ft/ft
 $n_{BACK} =$

Height of Curb at Gutter Flow Line
 Distance from Curb Face to Street Crown
 Gutter Width

$H_{CURB} =$ inches
 $T_{CROWN} =$ ft
 $W =$ ft

Street Transverse Slope
 Gutter Cross Slope (typically 2 inches over 24 inches or 0.083 ft/ft)
 Street Longitudinal Slope - Enter 0 for sump condition
 Manning's Roughness for Street Section (typically between 0.012 and 0.020)

$S_X =$ ft/ft
 $S_W =$ ft/ft
 $S_0 =$ ft/ft
 $n_{STREET} =$

Max. Allowable Spread for Minor & Major Storm
 Max. Allowable Depth at Gutter Flowline for Minor & Major Storm
 Check boxes are not applicable in SUMP conditions

	Minor Storm	Major Storm	
$T_{MAX} =$	<input type="text" value="13.0"/>	<input type="text" value="13.0"/>	ft
$d_{MAX} =$	<input type="text" value="6.0"/>	<input type="text" value="6.0"/>	inches
	<input type="checkbox"/>	<input type="checkbox"/>	

MINOR STORM Allowable Capacity is based on Depth Criterion
MAJOR STORM Allowable Capacity is based on Depth Criterion

$Q_{allow} =$

Minor Storm	Major Storm	
<input type="text" value="SUMP"/>	<input type="text" value="SUMP"/>	cfs

INLET IN A SUMP OR SAG LOCATION

Version 4.05 Released March 2017

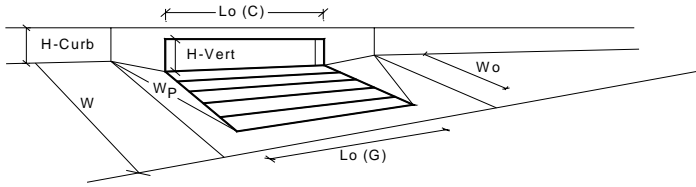

Design Information (Input)	MINOR	MAJOR	
Type of Inlet	CDOT Type R Curb Opening		
Local Depression (additional to continuous gutter depression 'a' from above)	3.00	3.00	inches
Number of Unit Inlets (Grate or Curb Opening)	1	1	
Water Depth at Flowline (outside of local depression)	3.9	3.9	inches
Grate Information	MINOR	MAJOR	<input type="checkbox"/> Override Depths
Length of a Unit Grate	N/A	N/A	feet
Width of a Unit Grate	N/A	N/A	feet
Area Opening Ratio for a Grate (typical values 0.15-0.90)	N/A	N/A	
Clogging Factor for a Single Grate (typical value 0.50 - 0.70)	N/A	N/A	
Grate Weir Coefficient (typical value 2.15 - 3.60)	N/A	N/A	
Grate Orifice Coefficient (typical value 0.60 - 0.80)	N/A	N/A	
Curb Opening Information	MINOR	MAJOR	
Length of a Unit Curb Opening	5.00	5.00	feet
Height of Vertical Curb Opening in Inches	6.00	6.00	inches
Height of Curb Orifice Throat in Inches	6.00	6.00	inches
Angle of Throat (see USDCM Figure ST-5)	63.40	63.40	degrees
Side Width for Depression Pan (typically the gutter width of 2 feet)	1.00	1.00	feet
Clogging Factor for a Single Curb Opening (typical value 0.10)	0.10	0.10	
Curb Opening Weir Coefficient (typical value 2.3-3.7)	3.60	3.60	
Curb Opening Orifice Coefficient (typical value 0.60 - 0.70)	0.67	0.67	
Low Head Performance Reduction (Calculated)	MINOR	MAJOR	
Depth for Grate Midwidth	N/A	N/A	ft
Depth for Curb Opening Weir Equation	0.24	0.24	ft
Combination Inlet Performance Reduction Factor for Long Inlets	0.50	0.50	
Curb Opening Performance Reduction Factor for Long Inlets	1.00	1.00	
Grated Inlet Performance Reduction Factor for Long Inlets	N/A	N/A	
Total Inlet Interception Capacity (assumes clogged condition)	MINOR	MAJOR	
Q_a	2.6	2.6	cfs
Q _{PEAK REQUIRED}	0.4	0.8	cfs

Inlet Capacity IS GOOD for Minor and Major Storms(>Q PEAK)

ALLOWABLE CAPACITY FOR ONE-HALF OF STREET (Minor & Major Storm)

(Based on Regulated Criteria for Maximum Allowable Flow Depth and Spread)

Project: **Parker & Pine Retail**
 Inlet ID: **Inlet A02**

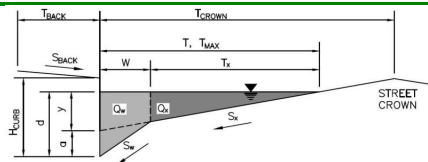

Gutter Geometry (Enter data in the blue cells)

Maximum Allowable Width for Spread Behind Curb
 Side Slope Behind Curb (leave blank for no conveyance credit behind curb)
 Manning's Roughness Behind Curb (typically between 0.012 and 0.020)

$T_{BACK} =$ ft
 $S_{BACK} =$ ft/ft
 $n_{BACK} =$

Height of Curb at Gutter Flow Line
 Distance from Curb Face to Street Crown

$H_{CURB} =$ inches
 $T_{CROWN} =$ ft

Gutter Width

$W =$ ft

Street Transverse Slope

$S_X =$ ft/ft

Gutter Cross Slope (typically 2 inches over 24 inches or 0.083 ft/ft)

$S_W =$ ft/ft

Street Longitudinal Slope - Enter 0 for sump condition

$S_0 =$ ft/ft

Manning's Roughness for Street Section (typically between 0.012 and 0.020)

$n_{STREET} =$

Max. Allowable Spread for Minor & Major Storm

	Minor Storm	Major Storm	
$T_{MAX} =$	<input type="text" value="13.0"/>	<input type="text" value="13.0"/>	ft
$d_{MAX} =$	<input type="text" value="6.0"/>	<input type="text" value="6.0"/>	inches

Max. Allowable Depth at Gutter Flowline for Minor & Major Storm

Allow Flow Depth at Street Crown (leave blank for no)

check = yes

MINOR STORM Allowable Capacity is based on Spread Criterion

MAJOR STORM Allowable Capacity is based on Spread Criterion

	Minor Storm	Major Storm	
$Q_{allow} =$	<input type="text" value="3.2"/>	<input type="text" value="3.2"/>	cfs

Minor storm max. allowable capacity GOOD - greater than the design flow given on sheet 'Inlet Management'

Major storm max. allowable capacity GOOD - greater than the design flow given on sheet 'Inlet Management'

INLET ON A CONTINUOUS GRADE

Version 4.05 Released March 2017

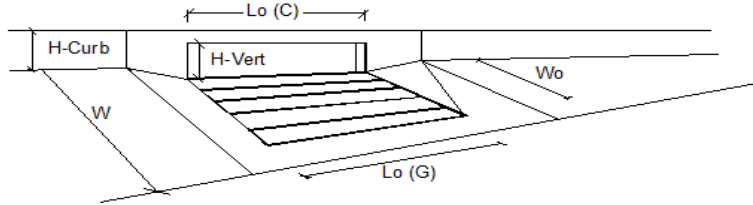

Design Information (Input)	MINOR		MAJOR	
Type of Inlet	CDOT Type R Curb Opening			
Local Depression (additional to continuous gutter depression 'a')	3.0	3.0	inches	
Total Number of Units in the Inlet (Grate or Curb Opening)	1	1		
Length of a Single Unit Inlet (Grate or Curb Opening)	5.00	5.00	ft	
Width of a Unit Grate (cannot be greater than W, Gutter Width)	N/A	N/A	ft	
Clogging Factor for a Single Unit Grate (typical min. value = 0.5)	N/A	N/A		
Clogging Factor for a Single Unit Curb Opening (typical min. value = 0.1)	0.10	0.10		
Street Hydraulics: OK - $Q < Q_{allowable}$ Street Capacity.				
Total Inlet Interception Capacity	0.6	1.4	cfs	
Total Inlet Carry-Over Flow (flow bypassing inlet)	0.0	0.3	cfs	
Capture Percentage = Q_i/Q_o =	100	80	%	

ALLOWABLE CAPACITY FOR ONE-HALF OF STREET (Minor & Major Storm)

(Based on Regulated Criteria for Maximum Allowable Flow Depth and Spread)

Project: **Parker & Pine Retail**
 Inlet ID: **Inlet C00**

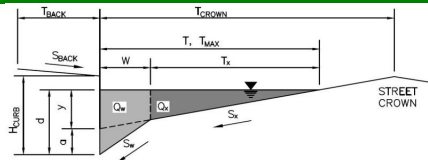

Gutter Geometry (Enter data in the blue cells)

Maximum Allowable Width for Spread Behind Curb
 Side Slope Behind Curb (leave blank for no conveyance credit behind curb)
 Manning's Roughness Behind Curb (typically between 0.012 and 0.020)

$T_{BACK} =$ ft
 $S_{BACK} =$ ft/ft
 $n_{BACK} =$

Height of Curb at Gutter Flow Line
 Distance from Curb Face to Street Crown
 Gutter Width
 Street Transverse Slope
 Gutter Cross Slope (typically 2 inches over 24 inches or 0.083 ft/ft)
 Street Longitudinal Slope - Enter 0 for sump condition
 Manning's Roughness for Street Section (typically between 0.012 and 0.020)

$H_{CURB} =$ inches
 $T_{CROWN} =$ ft
 $W =$ ft
 $S_X =$ ft/ft
 $S_W =$ ft/ft
 $S_0 =$ ft/ft
 $n_{STREET} =$

Max. Allowable Spread for Minor & Major Storm
 Max. Allowable Depth at Gutter Flowline for Minor & Major Storm
 Check boxes are not applicable in SUMP conditions

	Minor Storm	Major Storm	
$T_{MAX} =$	<input type="text" value="13.0"/>	<input type="text" value="13.0"/>	ft
$d_{MAX} =$	<input type="text" value="6.0"/>	<input type="text" value="6.0"/>	inches
	<input type="checkbox"/>	<input type="checkbox"/>	

MINOR STORM Allowable Capacity is based on Depth Criterion
MAJOR STORM Allowable Capacity is based on Depth Criterion

	Minor Storm	Major Storm	
$Q_{allow} =$	<input type="text" value="SUMP"/>	<input type="text" value="SUMP"/>	cfs

INLET IN A SUMP OR SAG LOCATION

Version 4.05 Released March 2017

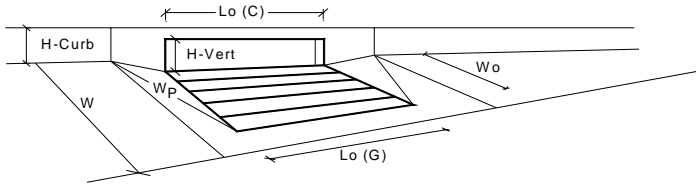

Design Information (Input)	MINOR	MAJOR	
Type of Inlet	CDOT Type R Curb Opening		
Local Depression (additional to continuous gutter depression 'a' from above)	3.00	3.00	inches
Number of Unit Inlets (Grate or Curb Opening)	1	1	
Water Depth at Flowline (outside of local depression)	3.9	3.9	inches
Grate Information	MINOR	MAJOR	<input type="checkbox"/> Override Depths
Length of a Unit Grate	N/A	N/A	feet
Width of a Unit Grate	N/A	N/A	feet
Area Opening Ratio for a Grate (typical values 0.15-0.90)	N/A	N/A	
Clogging Factor for a Single Grate (typical value 0.50 - 0.70)	N/A	N/A	
Grate Weir Coefficient (typical value 2.15 - 3.60)	N/A	N/A	
Grate Orifice Coefficient (typical value 0.60 - 0.80)	N/A	N/A	
Curb Opening Information	MINOR	MAJOR	
Length of a Unit Curb Opening	5.00	5.00	feet
Height of Vertical Curb Opening in Inches	6.00	6.00	inches
Height of Curb Orifice Throat in Inches	6.00	6.00	inches
Angle of Throat (see USDCM Figure ST-5)	63.40	63.40	degrees
Side Width for Depression Pan (typically the gutter width of 2 feet)	1.00	1.00	feet
Clogging Factor for a Single Curb Opening (typical value 0.10)	0.10	0.10	
Curb Opening Weir Coefficient (typical value 2.3-3.7)	3.60	3.60	
Curb Opening Orifice Coefficient (typical value 0.60 - 0.70)	0.67	0.67	
Low Head Performance Reduction (Calculated)	MINOR	MAJOR	
Depth for Grate Midwidth	N/A	N/A	ft
Depth for Curb Opening Weir Equation	0.24	0.24	ft
Combination Inlet Performance Reduction Factor for Long Inlets	0.50	0.50	
Curb Opening Performance Reduction Factor for Long Inlets	1.00	1.00	
Grated Inlet Performance Reduction Factor for Long Inlets	N/A	N/A	
Total Inlet Interception Capacity (assumes clogged condition)	MINOR	MAJOR	
Q_a	2.6	2.6	cfs
Q _{PEAK REQUIRED}	0.7	1.3	cfs

Inlet Capacity IS GOOD for Minor and Major Storms(>Q PEAK)

ALLOWABLE CAPACITY FOR ONE-HALF OF STREET (Minor & Major Storm)

(Based on Regulated Criteria for Maximum Allowable Flow Depth and Spread)

Project: **Parker & Pine Retail**
 Inlet ID: **Inlet A01**

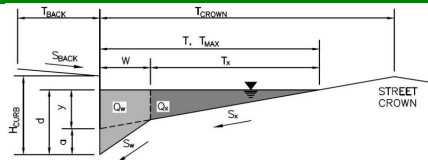

Gutter Geometry (Enter data in the blue cells)

Maximum Allowable Width for Spread Behind Curb
 Side Slope Behind Curb (leave blank for no conveyance credit behind curb)
 Manning's Roughness Behind Curb (typically between 0.012 and 0.020)

T_{BACK} = 0.0 ft
 S_{BACK} = ft/ft
 n_{BACK} = 0.012

Height of Curb at Gutter Flow Line
 Distance from Curb Face to Street Crown
 Gutter Width
 Street Transverse Slope
 Gutter Cross Slope (typically 2 inches over 24 inches or 0.083 ft/ft)
 Street Longitudinal Slope - Enter 0 for sump condition
 Manning's Roughness for Street Section (typically between 0.012 and 0.020)

H_{CURB} = 6.00 inches
 T_{CROWN} = 13.0 ft
 W = 1.00 ft
 S_x = 0.028 ft/ft
 S_w = 0.083 ft/ft
 S_o = 0.000 ft/ft
 n_{STREET} = 0.012

Max. Allowable Spread for Minor & Major Storm
 Max. Allowable Depth at Gutter Flowline for Minor & Major Storm
 Check boxes are not applicable in SUMP conditions

	Minor Storm	Major Storm	
T_{MAX}	13.0	13.0	ft
d_{MAX}	6.0	6.0	inches
	<input type="checkbox"/>	<input type="checkbox"/>	

MINOR STORM Allowable Capacity is based on Depth Criterion
MAJOR STORM Allowable Capacity is based on Depth Criterion

Q_{allow} =

Minor Storm	Major Storm
SUMP	SUMP

 cfs

INLET IN A SUMP OR SAG LOCATION

Version 4.05 Released March 2017

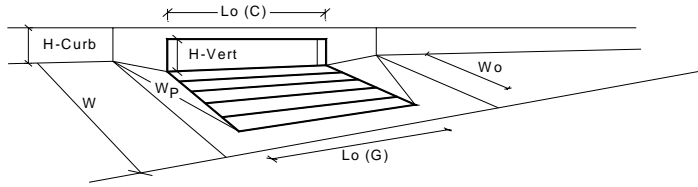

Design Information (Input)	MINOR	MAJOR	
Type of Inlet	CDOT Type R Curb Opening		
Local Depression (additional to continuous gutter depression 'a' from above)	3.00	3.00	inches
Number of Unit Inlets (Grate or Curb Opening)	1	1	
Water Depth at Flowline (outside of local depression)	5.1	5.1	inches
Grate Information	MINOR	MAJOR	<input type="checkbox"/> Override Depths
Length of a Unit Grate	N/A	N/A	feet
Width of a Unit Grate	N/A	N/A	feet
Area Opening Ratio for a Grate (typical values 0.15-0.90)	N/A	N/A	
Clogging Factor for a Single Grate (typical value 0.50 - 0.70)	N/A	N/A	
Grate Weir Coefficient (typical value 2.15 - 3.60)	N/A	N/A	
Grate Orifice Coefficient (typical value 0.60 - 0.80)	N/A	N/A	
Curb Opening Information	MINOR	MAJOR	
Length of a Unit Curb Opening	5.00	5.00	feet
Height of Vertical Curb Opening in Inches	6.00	6.00	inches
Height of Curb Orifice Throat in Inches	6.00	6.00	inches
Angle of Throat (see USDCM Figure ST-5)	63.40	63.40	degrees
Side Width for Depression Pan (typically the gutter width of 2 feet)	1.00	1.00	feet
Clogging Factor for a Single Curb Opening (typical value 0.10)	0.10	0.10	
Curb Opening Weir Coefficient (typical value 2.3-3.7)	3.60	3.60	
Curb Opening Orifice Coefficient (typical value 0.60 - 0.70)	0.67	0.67	
Low Head Performance Reduction (Calculated)	MINOR	MAJOR	
Depth for Grate Midwidth	N/A	N/A	ft
Depth for Curb Opening Weir Equation	0.34	0.34	ft
Combination Inlet Performance Reduction Factor for Long Inlets	0.65	0.65	
Curb Opening Performance Reduction Factor for Long Inlets	1.00	1.00	
Grated Inlet Performance Reduction Factor for Long Inlets	N/A	N/A	
Total Inlet Interception Capacity (assumes clogged condition)	MINOR	MAJOR	
Inlet Capacity IS GOOD for Minor and Major Storms(>Q PEAK)	4.3	4.3	cfs
Q PEAK REQUIRED	0.7	2.2	cfs

ALLOWABLE CAPACITY FOR ONE-HALF OF STREET (Minor & Major Storm)

(Based on Regulated Criteria for Maximum Allowable Flow Depth and Spread)

Project: **Parker & Pine Retail**
 Inlet ID: **Inlet B05**

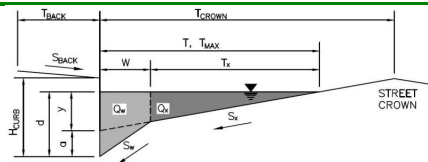

Gutter Geometry (Enter data in the blue cells)					
Maximum Allowable Width for Spread Behind Curb	$T_{BACK} = 0.0$ ft				
Side Slope Behind Curb (leave blank for no conveyance credit behind curb)	$S_{BACK} =$ ft/ft				
Manning's Roughness Behind Curb (typically between 0.012 and 0.020)	$n_{BACK} = 0.012$				
Height of Curb at Gutter Flow Line	$H_{CURB} = 6.00$ inches				
Distance from Curb Face to Street Crown	$T_{CROWN} = 13.0$ ft				
Gutter Width	$W = 1.00$ ft				
Street Transverse Slope	$S_X = 0.020$ ft/ft				
Gutter Cross Slope (typically 2 inches over 24 inches or 0.083 ft/ft)	$S_W = 0.083$ ft/ft				
Street Longitudinal Slope - Enter 0 for sump condition	$S_0 = 0.017$ ft/ft				
Manning's Roughness for Street Section (typically between 0.012 and 0.020)	$n_{STREET} = 0.012$				
Max. Allowable Spread for Minor & Major Storm	<table border="1"> <thead> <tr> <th>Minor Storm</th> <th>Major Storm</th> </tr> </thead> <tbody> <tr> <td>$T_{MAX} = 13.0$</td> <td>$T_{MAX} = 13.0$</td> </tr> </tbody> </table> ft	Minor Storm	Major Storm	$T_{MAX} = 13.0$	$T_{MAX} = 13.0$
Minor Storm	Major Storm				
$T_{MAX} = 13.0$	$T_{MAX} = 13.0$				
Max. Allowable Depth at Gutter Flowline for Minor & Major Storm	<table border="1"> <thead> <tr> <th>Minor Storm</th> <th>Major Storm</th> </tr> </thead> <tbody> <tr> <td>$d_{MAX} = 6.0$</td> <td>$d_{MAX} = 6.0$</td> </tr> </tbody> </table> inches	Minor Storm	Major Storm	$d_{MAX} = 6.0$	$d_{MAX} = 6.0$
Minor Storm	Major Storm				
$d_{MAX} = 6.0$	$d_{MAX} = 6.0$				
Allow Flow Depth at Street Crown (leave blank for no)	<table border="1"> <thead> <tr> <th>Minor Storm</th> <th>Major Storm</th> </tr> </thead> <tbody> <tr> <td><input type="checkbox"/></td> <td><input type="checkbox"/></td> </tr> </tbody> </table> check = yes	Minor Storm	Major Storm	<input type="checkbox"/>	<input type="checkbox"/>
Minor Storm	Major Storm				
<input type="checkbox"/>	<input type="checkbox"/>				
MINOR STORM Allowable Capacity is based on Spread Criterion					
MAJOR STORM Allowable Capacity is based on Spread Criterion					
Minor storm max. allowable capacity GOOD - greater than the design flow given on sheet 'Inlet Management'					
Major storm max. allowable capacity GOOD - greater than the design flow given on sheet 'Inlet Management'					
	<table border="1"> <thead> <tr> <th>Minor Storm</th> <th>Major Storm</th> </tr> </thead> <tbody> <tr> <td>$Q_{allow} = 8.7$</td> <td>$Q_{allow} = 8.7$</td> </tr> </tbody> </table> cfs	Minor Storm	Major Storm	$Q_{allow} = 8.7$	$Q_{allow} = 8.7$
Minor Storm	Major Storm				
$Q_{allow} = 8.7$	$Q_{allow} = 8.7$				

INLET ON A CONTINUOUS GRADE

Version 4.05 Released March 2017

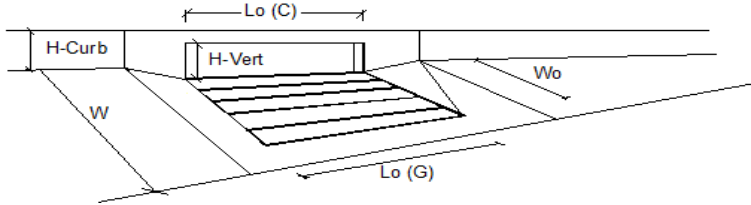

Design Information (Input)	CDOT Type R Curb Opening	MINOR	MAJOR	
Type of Inlet	CDOT Type R Curb Opening	Type =	CDOT Type R Curb Opening	
Local Depression (additional to continuous gutter depression 'a')		$a_{LOCAL} =$	3.0	3.0
Total Number of Units in the Inlet (Grate or Curb Opening)		No =	1	1
Length of a Single Unit Inlet (Grate or Curb Opening)		$L_o =$	5.00	5.00
Width of a Unit Grate (cannot be greater than W, Gutter Width)		$W_o =$	N/A	N/A
Clogging Factor for a Single Unit Grate (typical min. value = 0.5)		$C_r-G =$	N/A	N/A
Clogging Factor for a Single Unit Curb Opening (typical min. value = 0.1)		$C_r-C =$	0.10	0.10
Street Hydraulics: OK - $Q < Q_{allowable}$ Street Capacity.				
Total Inlet Interception Capacity		$Q =$	0.7	1.3
Total Inlet Carry-Over Flow (flow bypassing inlet)		$Q_b =$	0.0	0.1
Capture Percentage = $Q_i/Q_o =$		C% =	100	90
				%

ALLOWABLE CAPACITY FOR ONE-HALF OF STREET (Minor & Major Storm)

(Based on Regulated Criteria for Maximum Allowable Flow Depth and Spread)

Project: **Parker & Pine Retail**
 Inlet ID: **Inlet B03**

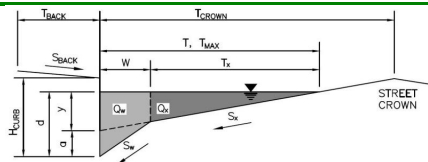

Gutter Geometry (Enter data in the blue cells)													
Maximum Allowable Width for Spread Behind Curb	$T_{BACK} =$ <input type="text" value="0.0"/> ft												
Side Slope Behind Curb (leave blank for no conveyance credit behind curb)	$S_{BACK} =$ <input type="text" value=""/> ft/ft												
Manning's Roughness Behind Curb (typically between 0.012 and 0.020)	$n_{BACK} =$ <input type="text" value="0.012"/>												
Height of Curb at Gutter Flow Line	$H_{CURB} =$ <input type="text" value="6.00"/> inches												
Distance from Curb Face to Street Crown	$T_{CROWN} =$ <input type="text" value="13.0"/> ft												
Gutter Width	$W =$ <input type="text" value="1.00"/> ft												
Street Transverse Slope	$S_X =$ <input type="text" value="0.019"/> ft/ft												
Gutter Cross Slope (typically 2 inches over 24 inches or 0.083 ft/ft)	$S_W =$ <input type="text" value="0.083"/> ft/ft												
Street Longitudinal Slope - Enter 0 for sump condition	$S_0 =$ <input type="text" value="0.038"/> ft/ft												
Manning's Roughness for Street Section (typically between 0.012 and 0.020)	$n_{STREET} =$ <input type="text" value="0.012"/>												
Max. Allowable Spread for Minor & Major Storm	<table border="1"> <thead> <tr> <th></th> <th>Minor Storm</th> <th>Major Storm</th> <th></th> </tr> </thead> <tbody> <tr> <td>$T_{MAX} =$</td> <td><input type="text" value="13.0"/></td> <td><input type="text" value="13.0"/></td> <td>ft</td> </tr> <tr> <td>$d_{MAX} =$</td> <td><input type="text" value="6.0"/></td> <td><input type="text" value="6.0"/></td> <td>inches</td> </tr> </tbody> </table>		Minor Storm	Major Storm		$T_{MAX} =$	<input type="text" value="13.0"/>	<input type="text" value="13.0"/>	ft	$d_{MAX} =$	<input type="text" value="6.0"/>	<input type="text" value="6.0"/>	inches
	Minor Storm	Major Storm											
$T_{MAX} =$	<input type="text" value="13.0"/>	<input type="text" value="13.0"/>	ft										
$d_{MAX} =$	<input type="text" value="6.0"/>	<input type="text" value="6.0"/>	inches										
Max. Allowable Depth at Gutter Flowline for Minor & Major Storm													
Allow Flow Depth at Street Crown (leave blank for no)	<input type="checkbox"/> <input type="checkbox"/> check = yes												
MINOR STORM Allowable Capacity is based on Spread Criterion													
MAJOR STORM Allowable Capacity is based on Spread Criterion													
Minor storm max. allowable capacity GOOD - greater than the design flow given on sheet 'Inlet Management'													
Major storm max. allowable capacity GOOD - greater than the design flow given on sheet 'Inlet Management'													
	<table border="1"> <thead> <tr> <th></th> <th>Minor Storm</th> <th>Major Storm</th> <th></th> </tr> </thead> <tbody> <tr> <td>$Q_{allow} =$</td> <td><input type="text" value="12.0"/></td> <td><input type="text" value="12.0"/></td> <td>cfs</td> </tr> </tbody> </table>		Minor Storm	Major Storm		$Q_{allow} =$	<input type="text" value="12.0"/>	<input type="text" value="12.0"/>	cfs				
	Minor Storm	Major Storm											
$Q_{allow} =$	<input type="text" value="12.0"/>	<input type="text" value="12.0"/>	cfs										

INLET ON A CONTINUOUS GRADE

Version 4.05 Released March 2017

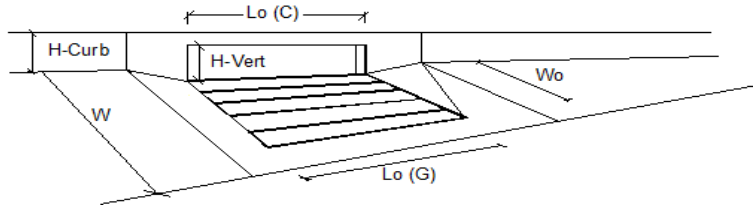

Design Information (Input)	MINOR	MAJOR	
Type of Inlet	CDOT Type R Curb Opening		
Local Depression (additional to continuous gutter depression 'a')	3.0	3.0	inches
Total Number of Units in the Inlet (Grate or Curb Opening)	1	1	
Length of a Single Unit Inlet (Grate or Curb Opening)	5.00	5.00	ft
Width of a Unit Grate (cannot be greater than W, Gutter Width)	N/A	N/A	ft
Clogging Factor for a Single Unit Grate (typical min. value = 0.5)	N/A	N/A	
Clogging Factor for a Single Unit Curb Opening (typical min. value = 0.1)	0.10	0.10	
Street Hydraulics: OK - Q < Allowable Street Capacity.			
Total Inlet Interception Capacity	0.7	1.2	cfs
Total Inlet Carry-Over Flow (flow bypassing inlet)	0.0	0.1	cfs
Capture Percentage = Q_i/Q_o =	100	93	%

ALLOWABLE CAPACITY FOR ONE-HALF OF STREET (Minor & Major Storm)

(Based on Regulated Criteria for Maximum Allowable Flow Depth and Spread)

Project: **Parker & Pine Retail**
 Inlet ID: **Inlet B08**

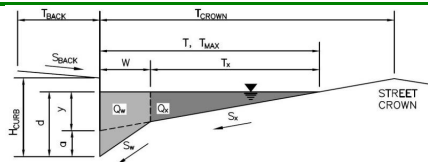

Gutter Geometry (Enter data in the blue cells)					
Maximum Allowable Width for Spread Behind Curb	$T_{BACK} = 0.0$ ft				
Side Slope Behind Curb (leave blank for no conveyance credit behind curb)	$S_{BACK} =$ ft/ft				
Manning's Roughness Behind Curb (typically between 0.012 and 0.020)	$n_{BACK} = 0.012$				
Height of Curb at Gutter Flow Line	$H_{CURB} = 6.00$ inches				
Distance from Curb Face to Street Crown	$T_{CROWN} = 13.0$ ft				
Gutter Width	$W = 1.00$ ft				
Street Transverse Slope	$S_X = 0.020$ ft/ft				
Gutter Cross Slope (typically 2 inches over 24 inches or 0.083 ft/ft)	$S_W = 0.083$ ft/ft				
Street Longitudinal Slope - Enter 0 for sump condition	$S_0 = 0.000$ ft/ft				
Manning's Roughness for Street Section (typically between 0.012 and 0.020)	$n_{STREET} = 0.012$				
Max. Allowable Spread for Minor & Major Storm	<table border="1"> <tr> <th>Minor Storm</th> <th>Major Storm</th> </tr> <tr> <td>$T_{MAX} = 13.0$</td> <td>$T_{MAX} = 13.0$</td> </tr> </table> ft	Minor Storm	Major Storm	$T_{MAX} = 13.0$	$T_{MAX} = 13.0$
Minor Storm	Major Storm				
$T_{MAX} = 13.0$	$T_{MAX} = 13.0$				
Max. Allowable Depth at Gutter Flowline for Minor & Major Storm	<table border="1"> <tr> <th>Minor Storm</th> <th>Major Storm</th> </tr> <tr> <td>$d_{MAX} = 6.0$</td> <td>$d_{MAX} = 9.0$</td> </tr> </table> inches	Minor Storm	Major Storm	$d_{MAX} = 6.0$	$d_{MAX} = 9.0$
Minor Storm	Major Storm				
$d_{MAX} = 6.0$	$d_{MAX} = 9.0$				
Check boxes are not applicable in SUMP conditions	<input type="checkbox"/> <input type="checkbox"/>				
MINOR STORM Allowable Capacity is based on Depth Criterion					
MAJOR STORM Allowable Capacity is based on Depth Criterion					
$Q_{allow} =$	<table border="1"> <tr> <th>Minor Storm</th> <th>Major Storm</th> </tr> <tr> <td>SUMP</td> <td>SUMP</td> </tr> </table> cfs	Minor Storm	Major Storm	SUMP	SUMP
Minor Storm	Major Storm				
SUMP	SUMP				

INLET IN A SUMP OR SAG LOCATION

Version 4.05 Released March 2017

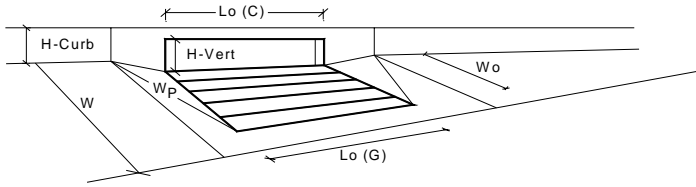

Design Information (Input)	MINOR	MAJOR	
Type of Inlet	CDOT Type R Curb Opening		
Local Depression (additional to continuous gutter depression 'a' from above)	3.00	3.00	inches
Number of Unit Inlets (Grate or Curb Opening)	1	1	
Water Depth at Flowline (outside of local depression)	3.9	3.9	inches
Grate Information	MINOR	MAJOR	<input type="checkbox"/> Override Depths
Length of a Unit Grate	N/A	N/A	feet
Width of a Unit Grate	N/A	N/A	feet
Area Opening Ratio for a Grate (typical values 0.15-0.90)	N/A	N/A	
Clogging Factor for a Single Grate (typical value 0.50 - 0.70)	N/A	N/A	
Grate Weir Coefficient (typical value 2.15 - 3.60)	N/A	N/A	
Grate Orifice Coefficient (typical value 0.60 - 0.80)	N/A	N/A	
Curb Opening Information	MINOR	MAJOR	
Length of a Unit Curb Opening	5.00	5.00	feet
Height of Vertical Curb Opening in Inches	6.00	6.00	inches
Height of Curb Orifice Throat in Inches	6.00	6.00	inches
Angle of Throat (see USDCM Figure ST-5)	63.40	63.40	degrees
Side Width for Depression Pan (typically the gutter width of 2 feet)	1.00	1.00	feet
Clogging Factor for a Single Curb Opening (typical value 0.10)	0.10	0.10	
Curb Opening Weir Coefficient (typical value 2.3-3.7)	3.60	3.60	
Curb Opening Orifice Coefficient (typical value 0.60 - 0.70)	0.67	0.67	
Low Head Performance Reduction (Calculated)	MINOR	MAJOR	
Depth for Grate Midwidth	N/A	N/A	ft
Depth for Curb Opening Weir Equation	0.24	0.24	ft
Combination Inlet Performance Reduction Factor for Long Inlets	0.50	0.50	
Curb Opening Performance Reduction Factor for Long Inlets	1.00	1.00	
Grated Inlet Performance Reduction Factor for Long Inlets	N/A	N/A	
Total Inlet Interception Capacity (assumes clogged condition)	MINOR	MAJOR	
Q_a	2.6	2.6	cfs
$Q_{PEAK REQUIRED}$	0.5	0.9	cfs

Inlet Capacity IS GOOD for Minor and Major Storms(>Q PEAK)

ALLOWABLE CAPACITY FOR ONE-HALF OF STREET (Minor & Major Storm)

(Based on Regulated Criteria for Maximum Allowable Flow Depth and Spread)

Project: **Parker & Pine Retail**
 Inlet ID: **Inlet B00**

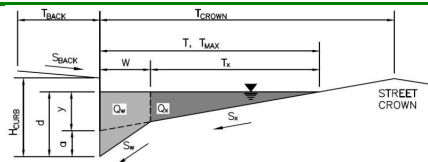

Gutter Geometry (Enter data in the blue cells)					
Maximum Allowable Width for Spread Behind Curb	$T_{BACK} = 0.0$ ft				
Side Slope Behind Curb (leave blank for no conveyance credit behind curb)	$S_{BACK} =$ ft/ft				
Manning's Roughness Behind Curb (typically between 0.012 and 0.020)	$n_{BACK} = 0.012$				
Height of Curb at Gutter Flow Line	$H_{CURB} = 6.00$ inches				
Distance from Curb Face to Street Crown	$T_{CROWN} = 13.0$ ft				
Gutter Width	$W = 1.00$ ft				
Street Transverse Slope	$S_X = 0.014$ ft/ft				
Gutter Cross Slope (typically 2 inches over 24 inches or 0.083 ft/ft)	$S_W = 0.083$ ft/ft				
Street Longitudinal Slope - Enter 0 for sump condition	$S_0 = 0.024$ ft/ft				
Manning's Roughness for Street Section (typically between 0.012 and 0.020)	$n_{STREET} = 0.012$				
Max. Allowable Spread for Minor & Major Storm	<table border="1"> <thead> <tr> <th>Minor Storm</th> <th>Major Storm</th> </tr> </thead> <tbody> <tr> <td>$T_{MAX} = 13.0$</td> <td>$T_{MAX} = 13.0$</td> </tr> </tbody> </table> ft	Minor Storm	Major Storm	$T_{MAX} = 13.0$	$T_{MAX} = 13.0$
Minor Storm	Major Storm				
$T_{MAX} = 13.0$	$T_{MAX} = 13.0$				
Max. Allowable Depth at Gutter Flowline for Minor & Major Storm	<table border="1"> <thead> <tr> <th>Minor Storm</th> <th>Major Storm</th> </tr> </thead> <tbody> <tr> <td>$d_{MAX} = 6.0$</td> <td>$d_{MAX} = 6.0$</td> </tr> </tbody> </table> inches	Minor Storm	Major Storm	$d_{MAX} = 6.0$	$d_{MAX} = 6.0$
Minor Storm	Major Storm				
$d_{MAX} = 6.0$	$d_{MAX} = 6.0$				
Allow Flow Depth at Street Crown (leave blank for no)	<table border="1"> <thead> <tr> <th>Minor Storm</th> <th>Major Storm</th> </tr> </thead> <tbody> <tr> <td><input type="checkbox"/></td> <td><input type="checkbox"/></td> </tr> </tbody> </table> check = yes	Minor Storm	Major Storm	<input type="checkbox"/>	<input type="checkbox"/>
Minor Storm	Major Storm				
<input type="checkbox"/>	<input type="checkbox"/>				
MINOR STORM Allowable Capacity is based on Spread Criterion					
MAJOR STORM Allowable Capacity is based on Spread Criterion					
Minor storm max. allowable capacity GOOD - greater than the design flow given on sheet 'Inlet Management'					
Major storm max. allowable capacity GOOD - greater than the design flow given on sheet 'Inlet Management'					
	<table border="1"> <thead> <tr> <th>Minor Storm</th> <th>Major Storm</th> </tr> </thead> <tbody> <tr> <td>$Q_{allow} = 5.9$</td> <td>$Q_{allow} = 5.9$</td> </tr> </tbody> </table> cfs	Minor Storm	Major Storm	$Q_{allow} = 5.9$	$Q_{allow} = 5.9$
Minor Storm	Major Storm				
$Q_{allow} = 5.9$	$Q_{allow} = 5.9$				

INLET ON A CONTINUOUS GRADE

Version 4.05 Released March 2017

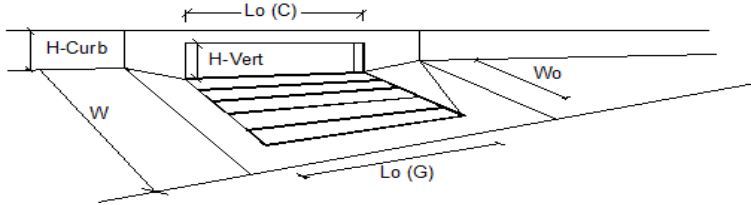

Design Information (Input)	MINOR	MAJOR	
Type of Inlet	CDOT Type R Curb Opening		
Local Depression (additional to continuous gutter depression 'a')	3.0	3.0	inches
Total Number of Units in the Inlet (Grate or Curb Opening)	1	1	
Length of a Single Unit Inlet (Grate or Curb Opening)	5.00	5.00	ft
Width of a Unit Grate (cannot be greater than W, Gutter Width)	N/A	N/A	ft
Clogging Factor for a Single Unit Grate (typical min. value = 0.5)	N/A	N/A	
Clogging Factor for a Single Unit Curb Opening (typical min. value = 0.1)	0.10	0.10	
Street Hydraulics: OK - Q < Allowable Street Capacity.			
Total Inlet Interception Capacity	0.3	1.6	cfs
Total Inlet Carry-Over Flow (flow bypassing inlet)	0.0	0.6	cfs
Capture Percentage = Q_i/Q_o =	100	72	%

ALLOWABLE CAPACITY FOR ONE-HALF OF STREET (Minor & Major Storm)

(Based on Regulated Criteria for Maximum Allowable Flow Depth and Spread)

Project: **Parker & Pine Retail**
 Inlet ID: **Inlet C01**

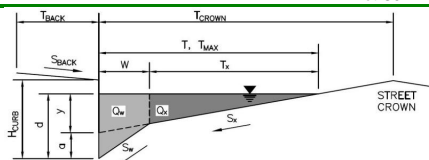

Gutter Geometry (Enter data in the blue cells)

Maximum Allowable Width for Spread Behind Curb
 Side Slope Behind Curb (leave blank for no conveyance credit behind curb)
 Manning's Roughness Behind Curb (typically between 0.012 and 0.020)

$T_{BACK} =$ ft
 $S_{BACK} =$ ft/ft
 $n_{BACK} =$

Height of Curb at Gutter Flow Line
 Distance from Curb Face to Street Crown
 Gutter Width
 Street Transverse Slope
 Gutter Cross Slope (typically 2 inches over 24 inches or 0.083 ft/ft)
 Street Longitudinal Slope - Enter 0 for sump condition
 Manning's Roughness for Street Section (typically between 0.012 and 0.020)

$H_{CURB} =$ inches
 $T_{CROWN} =$ ft
 $W =$ ft
 $S_X =$ ft/ft
 $S_W =$ ft/ft
 $S_0 =$ ft/ft
 $n_{STREET} =$

Max. Allowable Spread for Minor & Major Storm
 Max. Allowable Depth at Gutter Flowline for Minor & Major Storm
 Allow Flow Depth at Street Crown (leave blank for no)

	Minor Storm	Major Storm	
$T_{MAX} =$	<input type="text" value="13.0"/>	<input type="text" value="13.0"/>	ft
$d_{MAX} =$	<input type="text" value="6.0"/>	<input type="text" value="6.0"/>	inches
	<input type="checkbox"/>	<input type="checkbox"/>	check = yes

MINOR STORM Allowable Capacity is based on Spread Criterion
MAJOR STORM Allowable Capacity is based on Spread Criterion

	Minor Storm	Major Storm	
$Q_{allow} =$	<input type="text" value="11.3"/>	<input type="text" value="11.3"/>	cfs

Minor storm max. allowable capacity GOOD - greater than the design flow given on sheet 'Inlet Management'
Major storm max. allowable capacity GOOD - greater than the design flow given on sheet 'Inlet Management'

INLET ON A CONTINUOUS GRADE

Version 4.05 Released March 2017

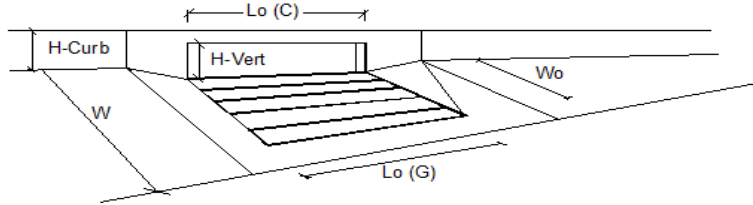

Design Information (Input)	CDOT Type R Curb Opening	MINOR	MAJOR	
Type of Inlet	CDOT Type R Curb Opening	Type =	CDOT Type R Curb Opening	
Local Depression (additional to continuous gutter depression 'a')		$a_{LOCAL} =$	3.0	3.0
Total Number of Units in the Inlet (Grate or Curb Opening)		No =	1	1
Length of a Single Unit Inlet (Grate or Curb Opening)		$L_o =$	5.00	5.00
Width of a Unit Grate (cannot be greater than W, Gutter Width)		$W_o =$	N/A	N/A
Clogging Factor for a Single Unit Grate (typical min. value = 0.5)		$C_r-G =$	N/A	N/A
Clogging Factor for a Single Unit Curb Opening (typical min. value = 0.1)		$C_r-C =$	0.10	0.10
Street Hydraulics: OK - $Q < Q_{allowable}$ Street Capacity.				
Total Inlet Interception Capacity		$Q =$	0.9	1.4
Total Inlet Carry-Over Flow (flow bypassing inlet)		$Q_b =$	0.0	0.2
Capture Percentage = $Q_c/Q_o =$		C% =	100	85
				cfs
				cfs
				%

APPENDIX E - REFERENCES

TOWN OF PARKER

AUG 13 2004

PLANNING DEPT.

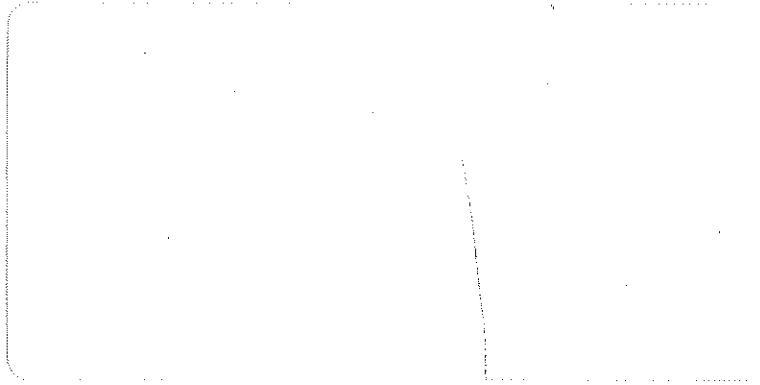

**Final Drainage Report
Parker Auto Plaza
Town of Parker
Douglas County, Colorado**

Prepared for:

Parker Auto Plaza, LLLP
% Concepts West Architecture
202 East Cheyenne Mountain Blvd.
Suite Q
Colorado Springs, Colorado 80906

Prepared by:

Kiowa Engineering Corporation
1604 South 21st Street
Colorado Springs, Colorado 80904

Kiowa Project No. 00056

July 12, 2004

ENGINEER'S STATEMENT:

This report for the final design of the Parker Auto Plaza development was prepared by me or under my direct supervision in accordance with the provisions of the Town of Parker Storm Drainage and Environmental Criteria Manual. I understand that the Town of Parker and its designated town authority do not and will not assume liability for drainage facilities designed by others.

Kiowa Engineering Corporation, 7175 W. Jefferson Ave Suite 3400, Lakewood, CO 80235

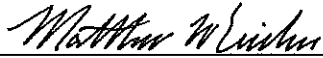

Registered Professional Engineer
State of Colorado # 36713
(For and on behalf of Kiowa Engineering Corp.)

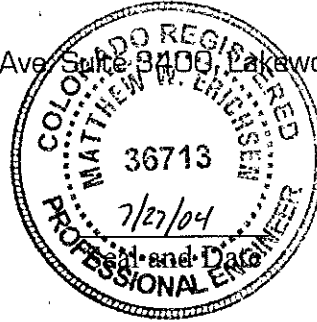

Table of Contents

Engineer's Statement	i
Table of Contents	ii
General Location and Description	1
Drainage Basins and Sub-Basins	
Major Basin Description	1
Site Sub-Basin Description	3
Floodplains.....	3
Drainage Design Criteria	
Regulations.....	4
Development Criteria Reference and Constraints	5
Hydrologic Criteria	5
Hydraulic Criteria.....	5
Drainage Facility Details	
General Concept.....	6
Drainage Basin and Storm Sewer System Description	6
Detention Basin Facility Description	7
Baldwin Gulch Drainageway Facility Description	8
Sculpted Concrete Drop – Cutoff Wall Analysis	9
Environmental Protection Criteria	9
Conclusions	10
References and Software	11
Appendix	12
See Appendix for Table of Contents	
List of Figures (Additional figures and tables are included in the Appendix)	
Figure 3 Vicinity Map.....	2
Figure 7 Future Major Watershed Boundaries and Reach Delineations	Appendix
Figure 8 Flood Insurance Rate Map.....	Appendix
Figure 9 Soil Survey Map	Appendix

General Location and Description

This report addresses the drainage impacts related to the Parker Auto Plaza development. The development will include construction of automobile sales facilities, an automobile body shop and future commercial site development. The property is located in the northwest quarter and southwest quarter of Section 10, Township 6 South, Range 66 West of the Sixth Principal Meridian. The property lies northwest of the intersection of Parker Road and Lincoln Avenue. It is bounded on the north by Pine Lane, on the east by Parker Road, Dransfeldt Road and MacLachlan Subdivision Nos. 1 & 2, on the south by Lincoln Avenue and on the west by the proposed extension alignment of Twenty Mile Road. The proposed Parker Auto Plaza site includes approximately 52.7 acres. A vicinity map of the area is included as Figure 3.

The site is covered by native vegetation, including weeds, sagebrush and a few large and smaller deciduous trees. Baldwin Gulch runs through the property from an existing box culvert under Parker Road to the proposed extension alignment of Twenty Mile Road.

Approximately 31.6 acres of the site will be utilized for the proposed commercial development sites described above. The 8.1 acres that surrounds Baldwin Gulch and the 100-year flood plain will be designated open space. This area will remain undeveloped except for a proposed trail and trailhead area and for channel improvements recommended in the *Baldwin Gulch Outfall Systems Planning Study* prepared by the Urban Drainage and Flood Control District.

Drainage Basins and Sub-Basins

Major Basin Description

The site was part of the MacLachlan Property (of which Filing Nos. 1 & 2 are currently developed). As a result of the review of the final drainage report for the MacLachlan Subdivision No. 1 (S.A. Miro, Inc., March 1994), and the *Newlin and Baldwin Gulches and Basin 4600-09 Outfall Systems Study Preliminary Design Report* (Kiowa Engineering Corporation, December 1994), it is apparent that the site lies within a portion of two major historic basins; Basin 4600-09 and Baldwin Gulch. Basin 4600-09 drains directly into Cherry Creek west of the site. A copy of the Future Major Watershed Boundaries and Reach Delineations, Baldwin Gulch basin 4600-09 is included in the Appendix of this report as Figure 7. The outfall for Baldwin Gulch into Cherry Creek is located approximately one-quarter mile west of the proposed extension of Twenty Mile Road. In the current condition it appears that a portion of the flows from the Basin 4600-09 section of the site are being diverted into Baldwin Gulch by the existing road in the Twenty Mile Road R.O.W. Existing drainage basins are shown on Figure 1 that is located in the map pocket at the end of this report.

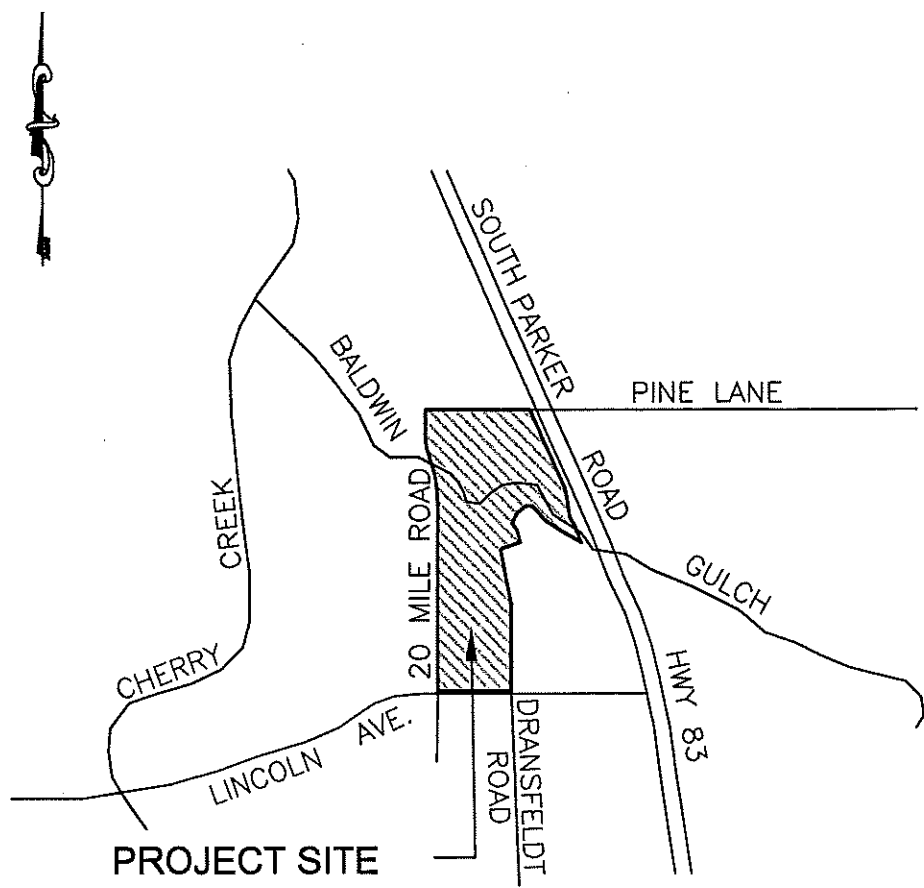

FIGURE 3
VICINITY MAP
PARKER AUTO PLAZA

Site Sub-Basin Description

Most of the flows from the developed lots within the MacLachlan subdivision drain to onsite detention basins. These detention basins in turn outfall directly into Baldwin Gulch and will remain in this condition. A small portion of Ponderosa Drive discharges onto the site in the current condition, and will be conveyed across the site by curb and gutter as Dransfeldt Road will be extended to Twenty Mile Road during the development of the site. Channel improvements will be made to Baldwin Gulch as part of the site development. The channel improvements noted in the *Newlin and Baldwin Gulches and Basin 4600-09 Outfall Systems Study (OSP) Preliminary Design Report* were reviewed during the Preliminary Drainage Report (PDR) for the site. The following modifications have been made to the channel improvements outlined in the *OSP* as part of the *PDR* review by UDFCD and the Town of Parker. Sculpted concrete drop structures have been substituted for the check structures shown in the *OSP*. The sculpted drop structures have replaced the checks so that the channel can be constructed to the ultimate longitudinal slope anticipated for sandy soils instead of allowing the channel to degrade over time with check structures as recommended in the *OSP*. This will minimize the amount of sediment that could be conveyed to Cherry Creek resulting from the degradation of the invert along this portion of Baldwin Gulch. The longitudinal slope of the channel was also modified from 0.94% to 0.6% to reduce the flow velocities in the channel. The proposed improvements to Baldwin Gulch are shown on the Drainage Plan, Figure 2. No further onsite drainage improvements are needed to convey flows from MacLachlan Subdivisions through the site.

The development of the site will not change the drainage patterns significantly onsite. However the increase in runoff that accompanies the development of the site will require the construction of two detention basins. The detention basins are located east of the future alignment of Twenty Mile Road to regulate discharge from the site into Baldwin Gulch. A storm sewer system will be required on the parcels south of Baldwin Gulch in order to convey site runoff from drainage basins 1B-12B into Detention Basin B south of Baldwin Gulch. A storm sewer system will also be required to convey flows from drainage basins 1A-5A to Detention Basin A (see Figure 2).

The existing and proposed grading precludes any treatment or detention of the runoff from Twenty Mile Road basins 3C and 4C and Pine Lane basins 1D and 2D. The Twenty Mile Road basins will be released to their historic Baldwin Gulch outfall location. The drainage basins along Pine Lane will be released to their historic outfall location westerly along the south edge of Pine Lane, eventually reaching Baldwin Gulch. The drainage improvements associated with Pine Lane will be completed as part of the Pine Lane extension project by Douglas County.

Floodplains

The Baldwin Gulch existing 100-year flood plain is shown on Figure 1 located in a map pocket at the end of this report. The 100-year flood plain boundary is based in part on the *1977 Flood Hazard Delineation (FHAD) Report* for Baldwin Gulch. The flood plain boundary was confirmed using Panel Number 080310 0070 D of the FEMA Flood Insurance Rate Map for

Douglas County, shown in Figure 8 which is located in the Appendix of this report. The development of this site will include channel improvements to Baldwin Gulch. These improvements, along with Detention Basin A south of Baldwin Gulch, east of the proposed Twenty Mile Road extension alignment will be the only grading that will occur within the 100-year floodplain. The construction of the channel improvements and attendant grading along the major drainageway will alter the 100-year floodway and floodplain through the site east of the proposed Twenty Mile Road extension. The proposed 100-year floodplain resulting from the proposed channel improvements is shown on Figure 2. A conditional Letter of Map Revision (CLOMR) will be required for this project. The submittal of a CLOMR to FEMA will commence once the design of the Baldwin Gulch improvements are generally approved and accepted by the Town of Parker and the Urban Drainage and Flood Control District.

Drainage Design Criteria

Regulations

In accordance with the Town of Parker's Floodplain ordinance, no temporary or permanent structures designed for human habitation will be placed in the floodplain. There will be a multi-use trail proposed along the Baldwin Gulch drainageway. The area adjacent to the low flow channel and on overbanks will be revegetated with native grasses, trees, and shrubs.

The development of this site will include improvements to the Baldwin Gulch channel, as stated above. These improvements include four sculpted concrete drop structures as well as grading the channel to conform to the recommended channel section and reinforcing the channel as necessary to minimize the adverse affects of erosion along Baldwin Gulch and the lands adjacent to it. A riprap lined low flow channel of 5-year capacity with a benched channel section above the low flow area is proposed. The total 100-year flooding depth along the channel through the site ranges from four to six-feet. A multi-use trail will follow the channel along the north bench of the drainageway, generally located above the 100-year floodplain. This trail will cross beneath proposed Twenty Mile Road in a three-sided box culvert. The upstream portion of the multi-use trail will cross under Parker Road through the north bay of the existing twin box culvert. The trail will loop up to Parker Road on the north side. The trail will continue south along Parker Road to the existing multi-use trail located on the south side of Baldwin Gulch and east of Parker Road. The plan and profile design for Baldwin Gulch has been included in a map pocket at the end of this report.

The proposed channel improvements will alter the existing channel section for the entire length of Baldwin Gulch within the project site. As a result of field meetings with the U. S. Army Corps of Engineers it was determined that a 404 Permit will not be required for the proposed channel improvements. It was determined that the portion of Baldwin Gulch through the site is not considered as jurisdictional waters of the United States.

Development Criteria Reference and Constraints

The Final Drainage Report for MacLachlan Subdivision No. 1 includes portions of this site in its analysis of historic drainage basins, however, drainage reports including developed conditions for this site could not be found. This drainage study generally agrees with the Final Drainage Report for MacLachlan Subdivision No. 1 concerning the historic drainage patterns for the site.

The Final Drainage Report for MacLachlan Subdivision No. 1 describes the developed flows of the neighboring subdivision. This study indicates that all flows aside from three small basins will be routed to a detention basin in MacLachlan Subdivision No. 1 and discharged directly into Baldwin Gulch. Two of the three small basins currently discharge onto the project site. When Dransfeldt Road is extended to Twenty Mile Road as a part of the development of this site, runoff from the offsite sub-basins currently discharging will be conveyed by curb and gutter to the storm sewer system in Dransfeldt Road and Twenty Mile Road and from there to Detention Basin B.

Hydrologic Criteria

Basin runoff was calculated using the Rational Method. Hydrology for Baldwin Gulch was obtained from the Newlin and Baldwin Gulches Outfall Systems Planning Study. The 5-year and 100-year peak discharges for the segment of Baldwin Gulch adjacent to the site are 260 cubic feet per second and 2,100 cubic feet per second, respectively.

Hydraulic Criteria

The drainage systems and street capacities for this site have been designed to accommodate the 5-year initial storm event and the 100-year major storm event as specified in the Town of Parker, Colorado, *Storm Drainage and Environmental Criteria Manual (SDECM)*. The hydraulic capacities of the curb inlets were determined using the UDINLET computer model developed by the University of Colorado at Denver. The initial storm event water spread was used to help determine the inlet locations in the site. Table 2.4 from the *SDECM* was used to determine the maximum allowable water spread for the initial storm runoff and has been included in the Appendix. An Inlet Capacity Summary spreadsheet is included in the Appendix, showing the inlet capacities and the minor storm water spread in tabular form. Colorado Department of Transportation (CDOT) Type R curb inlets will be used throughout the site. City of Denver Standard No. 16 Open Throat Inlets will be used in areas where there is insufficient area behind the curb for a curb-opening inlet.

Detention basins for this site have been designed to conform to the 10-year and 100-year regulated release rates per the aforementioned manual. Detention basins were sized and discharge rates determined using the UDFCD Detention Formulas. The supporting calculations associated with the sizing of hydraulic facilities for this development are included in the Appendix of this report.

Drainage Facility Details

General Concept

In the current condition, drainage from the proposed site flows into Baldwin Gulch. Calculations for the analysis of existing drainage basins are presented in the appendix at the end of this report. The existing Drainage Plan, including drainage basins are shown in Figure 1. The proposed development seeks to preserve the existing drainage patterns with the exception of routing flows through detention basins prior to discharging into Baldwin Gulch in order to limit flows from the developed site to acceptable levels. Calculations for the analysis of developed basins for this site, as well as calculations for the design of the detention basins and their tributary storm water conveyances are presented in the appendix of this report. The configuration of proposed basins and their related drainage facilities are presented in Figure 2. Offsite runoff impacting the site is minimal and will be conveyed across the site with the extension of Dransfeldt Road to be handled by the drainage facilities discharging to Detention Basin B.

Drainage Basin and Storm Sewer System Description

Runoff from Basin 1A will sheet-flow westerly through a parking lot area to a 10-foot sump curb inlet (Inlet 1). The flows captured by the inlet will be routed to Inlet 2. Drainage from Basin 2A will sheet-flow westerly through a parking lot area to a 15-foot curb inlet in sump condition. The flows will combine with flows from Inlet 1 and be carried by a storm sewer to Detention Basin A. Flows generated from Basin 3A will sheet-flow westerly through a parking lot area to a 10-foot sump curb inlet. A storm sewer will route the flows to Detention Basin A. Runoff generated from Basin 4A will sheet-flow southwesterly through a parking lot area to a 10-foot sump curb inlet. The flows will be routed to Detention Basin A by a storm sewer.

Runoff from Basin 1B will be carried northerly by curb and gutter along the western side of Twenty Mile Road. The runoff will be collected by a 15-foot on grade curb inlet at Dransfeldt Road. Runoff generated within Basin 2B will be carried northerly by curb and gutter along on the eastern side of Twenty Mile Road. The runoff will be collected by a 10-foot on grade curb inlet at Inlet 11. Drainage developed from Basin 3B will sheet-flow westerly through a parking lot area to be collected by a 15-foot sump curb inlet near Twenty Mile Road. The flow will then be carried by a 24-inch RCP to join with flows at Inlet 20. Runoff generated within Basin 4B will sheet-flow west through a parking lot area and will be collected by a 10-foot sump curb inlet. The flow will then be carried to Inlet 20 by a storm sewer. Drainage from Basin 5B will sheet-flow northwest through a parking lot area and will be collected by a 10-foot sump curb inlet. The flow will be routed to Inlet 19 through a storm sewer. Drainage from Basin 6B will sheet-flow northwest through a parking lot area and will be collected by a 5-foot sump curb inlet. The flow will be routed to Detention Basin B through a storm sewer. Drainage from Basin 7B will be carried northwest by the Dransfeldt Road curb and gutter to 15-foot curb inlets on grade at the intersection of Twenty Mile Road. A storm sewer will route the flows into the storm

sewer system along Twenty Mile Road. Runoff generated from Basin 8B will sheet-flow directly to Detention Basin B. Runoff generated from Basin 9B will sheet-flow westerly to a 15-foot sump curb inlet. At this point the runoff will combine with the flows in the 36-inch RCP storm sewer located along the east side of Twenty Mile Road (Twenty Mile Storm Sewer). The storm sewer will continue north to a manhole to the north of Dransfeldt Road. The Twenty Mile Storm Sewer will bend at this manhole and be directed into Detention Basin B. The runoff generated by Basin 10B will be carried along the gutter of the private drive extending into the commercial development area. The flows will continue along the east curb and gutter of Twenty Mile Road to a 20-foot inlet (Inlet 18) on grade at the intersection with Dransfeldt Road. The runoff captured by Inlet 20 will be directed into the Twenty Mile Storm Sewer. Runoff generated within Basin 11B will sheet-flow westerly through a parking lot area and will be collected by a 10-foot sump curb inlet near Twenty Mile Road. The flows will be routed into the Twenty Mile Storm Sewer. Runoff generated within Basin 12B will sheet-flow westerly through a parking lot area and will be collected by a 10-foot sump curb inlet near Twenty Mile Road.

Flows developed within Basin 1C will be carried southeasterly by a grass-lined swale to enter Baldwin Gulch. Runoff from Basin 2C will sheet-flow directly to Baldwin Gulch. Drainage Basins 3C-5C are located along a superelevated portion of Twenty Mile Road. Inlets have been located along this section of Twenty Mile Road to minimize the amount of flows crossing the street at points of superelevation. Drainage generated from Basin 3C will sheet-flow onto the west median curb line of Twenty Mile Road. An inlet will be placed along the west curb of Twenty Mile Road to capture the flows. The flows will be conveyed to Baldwin Gulch through a storm sewer. Flows from Basin 4C will be carried along the west curb and gutter of Twenty Mile Road to Inlet 27A. The flows will be routed by a storm sewer into Inlet 27. Flows from Basin 5C will flow onto the east curb and gutter of Twenty Mile Road to Inlet 25 at the low point. Flows from Basin 6C will flow along the east median curb and gutter of Twenty Mile Road to Inlet 26 at the low point. A storm sewer will route the flows to Inlet 26 and Baldwin Gulch. Runoff generated from Basins 1D and 2D will be handled as part of the Pine Lane Improvements. Runoff generated from Basin 1D is carried northerly along the west curb and gutter onto Pine Lane. The flows from Basin 2D will be captured by an inlet and conveyed to the Pine Lane storm sewer system.

Detention Basin Facility Description

The required detention volumes for Detention Basin A are 2.06 acre-feet for the 10-year event and 2.97 acre-feet for the 100-year event, which includes the WQCV. Calculations for this detention basin are located in the Appendix of this report. To control the release of flows and allow for pollutant removal, the detention basin is designed as an Extended Detention Basin Sedimentation Facility, as shown in Figure EDB-1 in Volume 3 of the Urban Storm Drainage Criteria Manual, found in the Appendix of this report. The design will include a forebay, trickle channel and emergency spillway. Modifications to the Figure EDB-1 design were made per the request of the Town of Parker. The modifications include the elimination of the micropool and

APPENDIX A
Hydrologic Calculations

**Parker Auto Plaza
Time of Concentration (Existing)**

Basin	Contributing Basins	Slope		Length		C _s O'land	Velocity		T _c		T _c
		O'land	Travel	O'land	Travel		O'land	Travel	O'land	Travel	
A		6.1 %	0.9 %	150 lf	1125 lf	0.01	0.2 ft/sec	0.5 ft/sec	788 sec.	2272 sec.	51.0 min.
B		2.4 %	2.5 %	150 lf	1105 lf	0.01	0.1 ft/sec	1.0 ft/sec	1077 sec.	1163 sec.	37.3 min.
C		1.9 %	2.4 %	150 lf	1659 lf	0.01	0.1 ft/sec	0.9 ft/sec	1158 sec.	1880 sec.	50.6 min.
D		2.5 %	3.4 %	150 lf	900 lf	0.01	0.1 ft/sec	1.1 ft/sec	1067 sec.	842 sec.	31.8 min.
E		1.5 %	3.9 %	150 lf	814 lf	0.01	0.1 ft/sec	0.8 ft/sec	1268 sec.	1072 sec.	39.0 min.

Equations:

$$\text{Time of Concentration (Overland)} = 1.8(1.1 - C_s)L^{0.5} S^{-0.333}$$

C_s = Runoff coefficient for five-year flow

L = Length of overland flow in feet (Length must be less than 1,000 feet for undeveloped area before entering a channel)

S = Slope of flow path in percent

**Parker Auto Plaza
Basin Runoff Calculation (Existing)**

Basin	Contributing Basins	Area		C		Time of Concentration	Rainfall Intensity		Runoff	
				C ₁₀	C ₁₀₀		i ₁₀	i ₁₀₀	Q ₁₀	Q ₁₀₀
A		519,090 sf	11.92 ac	0.05	0.20	51.0 min.	1.8 in/hr	2.9 in/hr	1.1 cfs	7.0 cfs
B		657,300 sf	15.09 ac	0.05	0.20	37.3 min.	2.3 in/hr	3.6 in/hr	1.7 cfs	10.8 cfs
C		512,500 sf	11.77 ac	0.05	0.20	50.6 min.	1.9 in/hr	2.9 in/hr	1.1 cfs	6.9 cfs
D		256,610 sf	5.89 ac	0.05	0.20	31.8 min.	2.5 in/hr	3.9 in/hr	0.7 cfs	4.6 cfs
E		354,940 sf	8.15 ac	0.05	0.20	39.0 min.	2.2 in/hr	3.5 in/hr	0.9 cfs	5.7 cfs

Equations:

$$I = (28.5P) / (10 + t_c)^{0.786}$$

P = One-hour point rainfall depth (in.) P(5yr)=1.39in. P(10yr)=1.64in. P(100yr)=2.60in.

i₅, i₁₀, i₁₀₀ = Average 5, 10 and 100-year Rainfall Intensity in inches per hour (Fig 5.1, Town of Parker Storm Drainage and Environmental Criteria Manual)

$$Q = CiA$$

Q = Peak Runoff Rate, in cubic feet per second (cfs)

C = Runoff coefficient representing a ration of peak runoff rate to average rainfall intensity for a duration equal to the runoff time of concentration.

i = average rainfall intensity in inches per hour

A = Drainage area in acres

Parker Auto Plaza
Runoff Coefficient Calculation (Developed)

Design Point	Basin	Area	% Area	C _s	C ₁₀₀	C _s	C ₁₀₀
DP 1	1A-4A	13.96 ac	90.31 %	0.81	0.88	0.73	0.79
	5A	1.50 ac	9.69 %	0.14	0.40	0.01	0.04
		15.45 ac	100.0 %			0.75	0.83

Design Point	Basin	Area	% Area	C _s	C ₁₀₀	C _s	C ₁₀₀
DP 2	1B,3B-7B,9B-13B	16.83 ac	85.84 %	0.81	0.88	0.70	0.76
	2B	0.94 ac	4.78 %	0.54	0.66	0.03	0.03
	8B	1.84 ac	9.38 %	0.14	0.40	0.01	0.04
		19.61 ac	100.0 %			0.73	0.82

Parker Auto Plaza
Time of Concentration (Developed)

Basin	Contributing Basins	Slope		Length		C _s	Velocity		t _c		Comp. t _c	t _c Check	Final t _c
		O'land	Travel	O'land	Travel		O'land	Travel (Fig. RO-1)	O'land (t _c)	Travel (t _c)			
1A		8.0 %	3.0 %	85 lf	430 lf	0.14	0.2 ft/sec	3.4 ft/sec	8.0 min.	2.1 min.	10.1 min.	12.9 min.	10.1 min.
2A		3.0 %	3.0 %	100 lf	360 lf	0.14	0.1 ft/sec	3.4 ft/sec	12.0 min.	1.8 min.	13.8 min.	12.6 min.	12.6 min.
3A		1.0 %	3.0 %	80 lf	410 lf	0.14	0.1 ft/sec	3.4 ft/sec	15.5 min.	2.0 min.	17.5 min.	12.7 min.	12.7 min.
4A		3.0 %	1.3 %	70 lf	350 lf	0.14	0.1 ft/sec	2.2 ft/sec	10.0 min.	2.7 min.	12.7 min.	12.3 min.	12.3 min.
5A		4.0 %	1.0 %	110 lf	50 lf	0.14	0.2 ft/sec	1.6 ft/sec	11.4 min.	0.5 min.	11.9 min.	10.9 min.	10.9 min.
1B		3.0 %	1.5 %	20 lf	500 lf	0.14	0.1 ft/sec	2.3 ft/sec	5.4 min.	3.6 min.	9.0 min.	12.9 min.	9.0 min.
2B		1.0 %	1.5 %	200 lf	550 lf	0.14	0.1 ft/sec	2.3 ft/sec	24.4 min.	4.0 min.	28.4 min.	14.2 min.	14.2 min.
3B		3.0 %	1.0 %	60 lf	230 lf	0.14	0.1 ft/sec	2.0 ft/sec	9.3 min.	1.9 min.	11.2 min.	11.6 min.	11.2 min.
4B		8.0 %	2.5 %	30 lf	350 lf	0.14	0.1 ft/sec	3.1 ft/sec	4.7 min.	1.9 min.	6.6 min.	12.1 min.	6.6 min.
5B		8.0 %	2.0 %	40 lf	300 lf	0.14	0.1 ft/sec	2.8 ft/sec	5.5 min.	1.8 min.	7.3 min.	11.9 min.	7.3 min.
6B		3.0 %	3.5 %	60 lf	400 lf	0.14	0.1 ft/sec	3.7 ft/sec	9.3 min.	1.8 min.	11.1 min.	12.6 min.	11.1 min.
7B		4.0 %	4.5 %	15 lf	540 lf	0.14	0.1 ft/sec	4.2 ft/sec	4.2 min.	2.1 min.	6.4 min.	13.1 min.	6.4 min.
8B		3.0 %	1.0 %	80 lf	140 lf	0.14	0.1 ft/sec	1.6 ft/sec	10.7 min.	1.5 min.	12.2 min.	11.2 min.	11.2 min.
9B		5.0 %	3.0 %	50 lf	350 lf	0.14	0.1 ft/sec	3.4 ft/sec	7.1 min.	1.7 min.	8.9 min.	12.2 min.	8.9 min.
10B		3.0 %	2.5 %	20 lf	500 lf	0.14	0.1 ft/sec	3.1 ft/sec	5.4 min.	2.7 min.	8.0 min.	12.9 min.	8.0 min.
11B		3.0 %	2.5 %	25 lf	250 lf	0.14	0.1 ft/sec	3.1 ft/sec	6.0 min.	1.3 min.	7.3 min.	11.5 min.	7.3 min.
12B		3.0 %	2.5 %	50 lf	400 lf	0.14	0.1 ft/sec	3.1 ft/sec	8.5 min.	2.2 min.	10.6 min.	12.5 min.	10.6 min.
13B		1.0 %	1.0 %	150 lf	450 lf	0.14	0.1 ft/sec	2.0 ft/sec	21.2 min.	3.8 min.	24.9 min.	13.3 min.	13.3 min.
1C		1.0 %	2.0 %	200 lf	450 lf	0.14	0.1 ft/sec	1.0 ft/sec	24.4 min.	7.5 min.	31.9 min.	13.6 min.	13.6 min.
2C		1.0 %	1.0 %	25 lf	1490 lf	0.14	0.0 ft/sec	1.5 ft/sec	8.6 min.	16.6 min.	25.2 min.	18.4 min.	18.4 min.
3C		2.0 %	1.0 %	150 lf	700 lf	0.14	0.1 ft/sec	3.4 ft/sec	16.8 min.	3.4 min.	20.2 min.	14.7 min.	14.7 min.
4C		1.0 %	1.1 %	10 lf	500 lf	0.14	0.0 ft/sec	2.1 ft/sec	5.5 min.	4.0 min.	9.4 min.	12.8 min.	9.4 min.
5C		2.0 %	1.0 %	60 lf	200 lf	0.14	0.1 ft/sec	3.4 ft/sec	10.6 min.	1.0 min.	11.6 min.	11.4 min.	11.4 min.
6C		2.0 %	1.0 %	10 lf	340 lf	0.14	0.0 ft/sec	1.6 ft/sec	4.3 min.	3.5 min.	7.9 min.	11.9 min.	7.9 min.
7C		2.0 %	1.0 %	10 lf	220 lf	0.90	0.2 ft/sec	3.4 ft/sec	0.9 min.	1.1 min.	5.0 min.	11.3 min.	5.0 min.
1D		2.0 %	2.0 %	10 lf	350 lf	0.14	0.0 ft/sec	2.8 ft/sec	4.3 min.	2.1 min.	6.4 min.	12.0 min.	6.4 min.
2D		10.0 %	3.0 %	30 lf	100 lf	0.14	0.1 ft/sec	3.4 ft/sec	4.4 min.	0.5 min.	5.0 min.	10.7 min.	5.0 min.
3D		10.0 %	3.0 %	10 lf	400 lf	0.14	0.1 ft/sec	3.4 ft/sec	2.5 min.	2.0 min.	5.0 min.	12.3 min.	5.0 min.
DP 1	A Basins	1.0 %	3.0 %	80 lf	410 lf	0.14	0.1 ft/sec	3.4 ft/sec	15.5 min.	2.0 min.	17.5 min.	12.7 min.	12.7 min.
DP 2	B Basins	3.0 %	1.5 %	80 lf	1560 lf	0.14	0.1 ft/sec	2.3 ft/sec	10.7 min.	11.3 min.	22.0 min.	19.1 min.	19.1 min.

Equations:

$$t_i (\text{Overland}) = 1.8(1.1 - C_s)L^{0.5} S^{-0.333}$$

C_s = Runoff coefficient for five-year flow

L = Length of overland flow in feet

S = Slope of flow path in percent

$$t_c \text{ Check} = (L/180) + 10$$

L = Overall Length

Fig. RO-1: Average velocities for Estimating Travel Time

Parker Auto Plaza
Basin Runoff Calculation (Developed)

Basin	Contributing Basins	Area		C _s	C ₁₀₀	Time of Concentration	Rainfall Intensity		Runoff		Basin
							i ₅	i ₁₀₀	Q ₅	Q ₁₀₀	
1A		124,700 sf	2.86 ac	0.81	0.88	10.1 min.	3.7 in/hr	7.0 in/hr	8.7 cfs	17.7 cfs	1A
2A		158,280 sf	3.63 ac	0.81	0.88	12.6 min.	3.4 in/hr	6.4 in/hr	10.1 cfs	20.5 cfs	2A
3A		149,800 sf	3.44 ac	0.81	0.88	12.7 min.	3.4 in/hr	6.4 in/hr	9.5 cfs	19.3 cfs	3A
4A		175,180 sf	4.02 ac	0.81	0.88	12.3 min.	3.4 in/hr	6.4 in/hr	11.2 cfs	22.8 cfs	4A
5A		65,250 sf	1.50 ac	0.14	0.40	10.9 min.	3.6 in/hr	6.8 in/hr	0.8 cfs	4.1 cfs	5A
1B		26,630 sf	0.61 ac	0.81	0.88	9.0 min.	3.9 in/hr	7.3 in/hr	1.9 cfs	3.9 cfs	1B
2B		40,850 sf	0.94 ac	0.54	0.66	14.2 min.	3.2 in/hr	6.1 in/hr	1.6 cfs	3.8 cfs	2B
3B		114,100 sf	2.62 ac	0.81	0.88	11.2 min.	3.6 in/hr	6.7 in/hr	7.6 cfs	15.5 cfs	3B
4B		83,300 sf	1.91 ac	0.81	0.88	6.6 min.	4.4 in/hr	8.1 in/hr	6.7 cfs	13.7 cfs	4B
5B		71,200 sf	1.63 ac	0.81	0.88	7.3 min.	4.2 in/hr	7.9 in/hr	5.6 cfs	11.4 cfs	5B
6B		63,550 sf	1.46 ac	0.81	0.88	11.1 min.	3.6 in/hr	6.7 in/hr	4.3 cfs	8.7 cfs	6B
7B		51,720 sf	1.19 ac	0.81	0.88	6.4 min.	4.4 in/hr	8.2 in/hr	4.2 cfs	8.6 cfs	7B
8B		80,100 sf	1.84 ac	0.14	0.40	11.2 min.	3.6 in/hr	6.7 in/hr	0.9 cfs	4.9 cfs	8B
9B		116,400 sf	2.67 ac	0.81	0.88	8.9 min.	3.9 in/hr	7.4 in/hr	8.5 cfs	17.3 cfs	9B
10B		46,600 sf	1.07 ac	0.81	0.88	8.0 min.	4.1 in/hr	7.6 in/hr	3.5 cfs	7.2 cfs	10B
11B		59,600 sf	1.37 ac	0.81	0.88	7.3 min.	4.2 in/hr	7.9 in/hr	4.7 cfs	9.5 cfs	11B
12B		100,200 sf	2.30 ac	0.81	0.88	10.6 min.	3.7 in/hr	6.9 in/hr	6.8 cfs	13.9 cfs	12B
13B		65,200 sf	1.50 ac	0.81	0.88	13.3 min.	3.3 in/hr	6.2 in/hr	4.0 cfs	8.2 cfs	13B
1C		72,910 sf	1.67 ac	0.54	0.66	13.6 min.	3.3 in/hr	6.2 in/hr	3.0 cfs	6.8 cfs	1C
2C		361,300 sf	8.29 ac	0.14	0.40	18.4 min.	2.9 in/hr	5.3 in/hr	3.3 cfs	17.7 cfs	2C
3C		43,100 sf	0.99 ac	0.81	0.88	14.7 min.	3.2 in/hr	6.0 in/hr	2.6 cfs	5.2 cfs	3C
4C		32,500 sf	0.75 ac	0.81	0.88	9.4 min.	3.8 in/hr	7.2 in/hr	2.3 cfs	4.7 cfs	4C
5C		42,640 sf	0.98 ac	0.81	0.88	11.4 min.	3.6 in/hr	6.7 in/hr	2.8 cfs	5.7 cfs	5C
6C		22,020 sf	0.51 ac	0.81	0.88	7.9 min.	4.1 in/hr	7.7 in/hr	1.7 cfs	3.4 cfs	6C
7C		37,700 sf	0.87 ac	0.90	0.96	5.0 min.	4.7 in/hr	8.8 in/hr	3.7 cfs	7.3 cfs	7C
1D		21,080 sf	0.48 ac	0.81	0.88	6.4 min.	4.4 in/hr	8.2 in/hr	1.7 cfs	3.5 cfs	1D
2D		17,360 sf	0.40 ac	0.81	0.88	5.0 min.	4.7 in/hr	8.8 in/hr	1.5 cfs	3.1 cfs	2D
3D		25,680 sf	0.59 ac	0.81	0.88	5.0 min.	4.7 in/hr	8.8 in/hr	2.3 cfs	4.6 cfs	3D
DP 1	A Basins	673,210 sf	15.45 ac	0.75	0.83	12.7 min.	3.4 in/hr	6.4 in/hr	39 cfs	82 cfs	DP 1
DP 2	B Basins	919,450 sf	21.11 ac	0.74	0.83	19.1 min.	2.8 in/hr	5.2 in/hr	44 cfs	92 cfs	DP 2

Equations:

$$I = (28.5P) / (10 + t_c)^{0.786}$$

P=One-hour point rainfall depth (in.) P(5yr)=1.39in. P(100yr)=2.60in.

i₅, i₁₀, i₁₀₀=Average 5, 10 and 100-year Rainfall Intensity in inches per hour (Fig 5.1, Town of Parker Storm Drainage and Environmental Criteria Manual)

$$Q = CiA$$

Q = Peak Runoff Rate, in cubic feet per second (cfs) {Initial Storm=Q₅ Major Storm=Q₁₀₀}

C = Runoff coefficient representing a ration of peak runoff rate to average rainfall intensity for a duration equal to the runoff time of concentration.

i = average rainfall intensity in inches per hour

A = Drainage area in acres

TABLE RO-3

Recommended Percentage Imperviousness Values

Land Use or Surface Characteristics	Percentage Imperviousness
Business:	
Commercial areas	95
Neighborhood areas	85
Residential:	
Single-family	*
Multi-unit (detached)	60
Multi-unit (attached)	75
Half-acre lot or larger	*
Apartments	80
Industrial:	
Light areas	80
Heavy areas	90
Parks, cemeteries	5
Playgrounds	10
Schools	50
Railroad yard areas	15
Undeveloped Areas:	
Historic flow analysis	2
Greenbelts, agricultural	2
Off-site flow analysis (when land use not defined)	45
Streets:	
Paved	100
Gravel (packed)	40
Drive and walks	90
Roofs	90
Lawns, sandy soil	0
Lawns, clayey soil	0

* See Figures RO-3 through RO-5 for percentage imperviousness.

Based in part on the data collected by the District since 1969, an empirical relationship between C and the percentage imperviousness for various storm return periods was developed. Thus, values for C can be determined using the following equations (Urbonas, Guo and Tucker 1990).

$$C_A = K_A + (1.31i^3 - 1.44i^2 + 1.135i - 0.12) \text{ for } C_A \geq 0, \text{ otherwise } C_A = 0 \quad (\text{RO-6})$$

$$C_{CD} = K_{CD} + (0.858i^3 - 0.786i^2 + 0.774i + 0.04) \quad (\text{RO-7})$$

$$C_B = (C_A + C_{CD})/2$$

in which:

i = % imperviousness/100 expressed as a decimal (see Table RO-3)

TABLE RO-5
Runoff Coefficients, C

Percentage Imperviousness	Type C and D NRCS Hydrologic Soil Groups					
	2-yr	5-yr	10-yr	25-yr	50-yr	100-yr
0%	0.04	0.15	0.25	0.37	0.44	0.50
5%	0.08	0.18	0.28	0.39	0.46	0.52
10%	0.11	0.21	0.30	0.41	0.47	0.53
15%	0.14	0.24	0.32	0.43	0.49	0.54
20%	0.17	0.26	0.34	0.44	0.50	0.55
25%	0.20	0.28	0.36	0.46	0.51	0.56
30%	0.22	0.30	0.38	0.47	0.52	0.57
35%	0.25	0.33	0.40	0.48	0.53	0.57
40%	0.28	0.35	0.42	0.50	0.54	0.58
45%	0.31	0.37	0.44	0.51	0.55	0.59
50%	0.34	0.40	0.46	0.53	0.57	0.60
55%	0.37	0.43	0.48	0.55	0.58	0.62
60%	0.41	0.46	0.51	0.57	0.60	0.63
65%	0.45	0.49	0.54	0.59	0.62	0.65
70%	0.49	0.53	0.57	0.62	0.65	0.68
75%	0.54	0.58	0.62	0.66	0.68	0.71
80%	0.60	0.63	0.66	0.70	0.72	0.74
85%	0.66	0.68	0.71	0.75	0.77	0.79
90%	0.73	0.75	0.77	0.80	0.82	0.83
95%	0.80	0.82	0.84	0.87	0.88	0.89
100%	0.89	0.90	0.92	0.94	0.95	0.96

Type B NRCS Hydrologic Soils Group						
0%	0.02	0.08	0.15	0.25	0.30	0.35
5%	0.04	0.10	0.19	0.28	0.33	0.38
10%	0.06	0.14	0.22	0.31	0.36	0.40
15%	0.08	0.17	0.25	0.33	0.38	0.42
20%	0.12	0.20	0.27	0.35	0.40	0.44
25%	0.15	0.22	0.30	0.37	0.41	0.46
30%	0.18	0.25	0.32	0.39	0.43	0.47
35%	0.20	0.27	0.34	0.41	0.44	0.48
40%	0.23	0.30	0.36	0.42	0.46	0.50
45%	0.26	0.32	0.38	0.44	0.48	0.51
50%	0.29	0.35	0.40	0.46	0.49	0.52
55%	0.33	0.38	0.43	0.48	0.51	0.54
60%	0.37	0.41	0.46	0.51	0.54	0.56
65%	0.41	0.45	0.49	0.54	0.57	0.59
70%	0.45	0.49	0.53	0.58	0.60	0.62
75%	0.51	0.54	0.58	0.62	0.64	0.66
80%	0.57	0.59	0.63	0.66	0.68	0.70
85%	0.63	0.66	0.69	0.72	0.73	0.75
90%	0.71	0.73	0.75	0.78	0.80	0.81
95%	0.79	0.81	0.83	0.85	0.87	0.88
100%	0.89	0.90	0.92	0.94	0.95	0.96

TYPE B

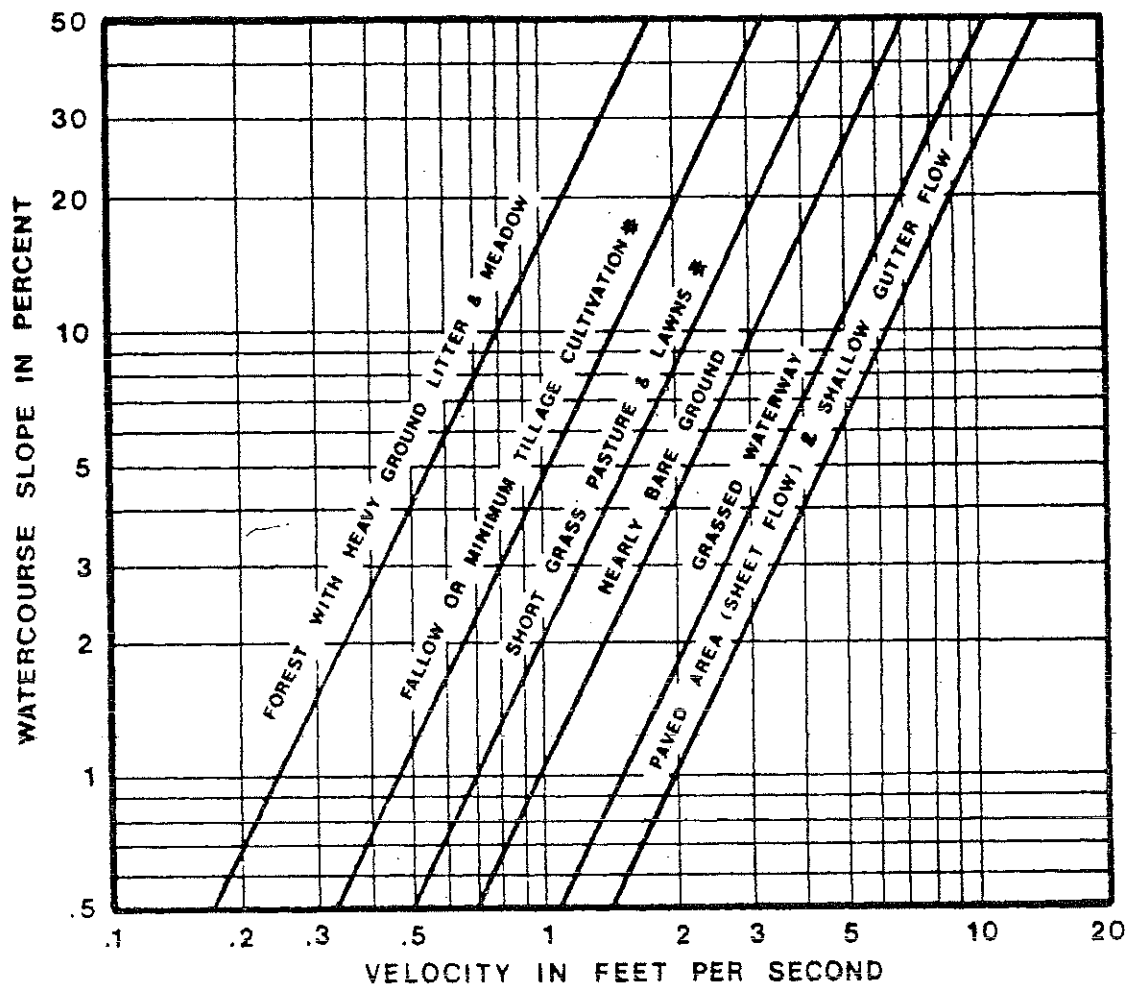

FIGURE RO-1

Estimate of Average Overland Flow Velocity for Use With the Rational Formula

5.1 INTRODUCTION

This section presents the criteria and methodology for determining storm runoff design peaks and volumes to be used in the Town of Parker for preparation of storm drainage plans and facility design. In general hydrologic analysis of the initial and major storm events for both the historic and fully developed site conditions are required. In addition to the hydrologic analysis for a site, a hydrologic analysis should be performed for all off site basins that impact the proposed site. The Town of Parker adopts procedures prescribed by the Urban Drainage and Flood Control District (District) for performing hydrologic analysis. These procedures may be found in the Rainfall and Runoff sections of the MANUAL. Standards and technical criteria found in the MANUAL should be followed except where superseded by specific requirements of this criteria MANUAL.

5.2 DESIGN RAINFALL

For any storm runoff technique, design rainfall must first be established. The design rainfall data to be used for the Town of Parker were obtained from NOAA Atlas 2, Precipitation-Frequency Atlas of the Western United States, Volume III- Colorado. The design storm events developed and utilized are the same as those used by the District.

The one-hour point rainfall depths for different frequency events are shown in Table 5.1. Rainfall intensity as a function of the one-hour point rainfall and the time of concentration can be approximated by the following equation which appears in the MANUAL as Equation RA-5.

$$I = (28.5P_1)/(10+t_c)^{0.786}$$

Where, I = rainfall intensity (in/hr)
 P_1 = one-hour point rainfall depth (in)
 t_c = time of concentration (min)

Graphical presentation of the equation is shown as the Time-Intensity-Frequency curves in Figure 5.1. Rainfall intensity for use in the Rational Method may be taken from Figure 5.1 or calculated using the equation.

Table 5.1
ONE-HOUR POINT RAINFALL

Frequency of Design Event (yr)	One-hour Point Rainfall, P_1 (in)
2	0.99
5	1.39
10	1.64
25	1.98
50	2.31
100	2.60

Intensity, Duration, Frequency
Parker, Colorado

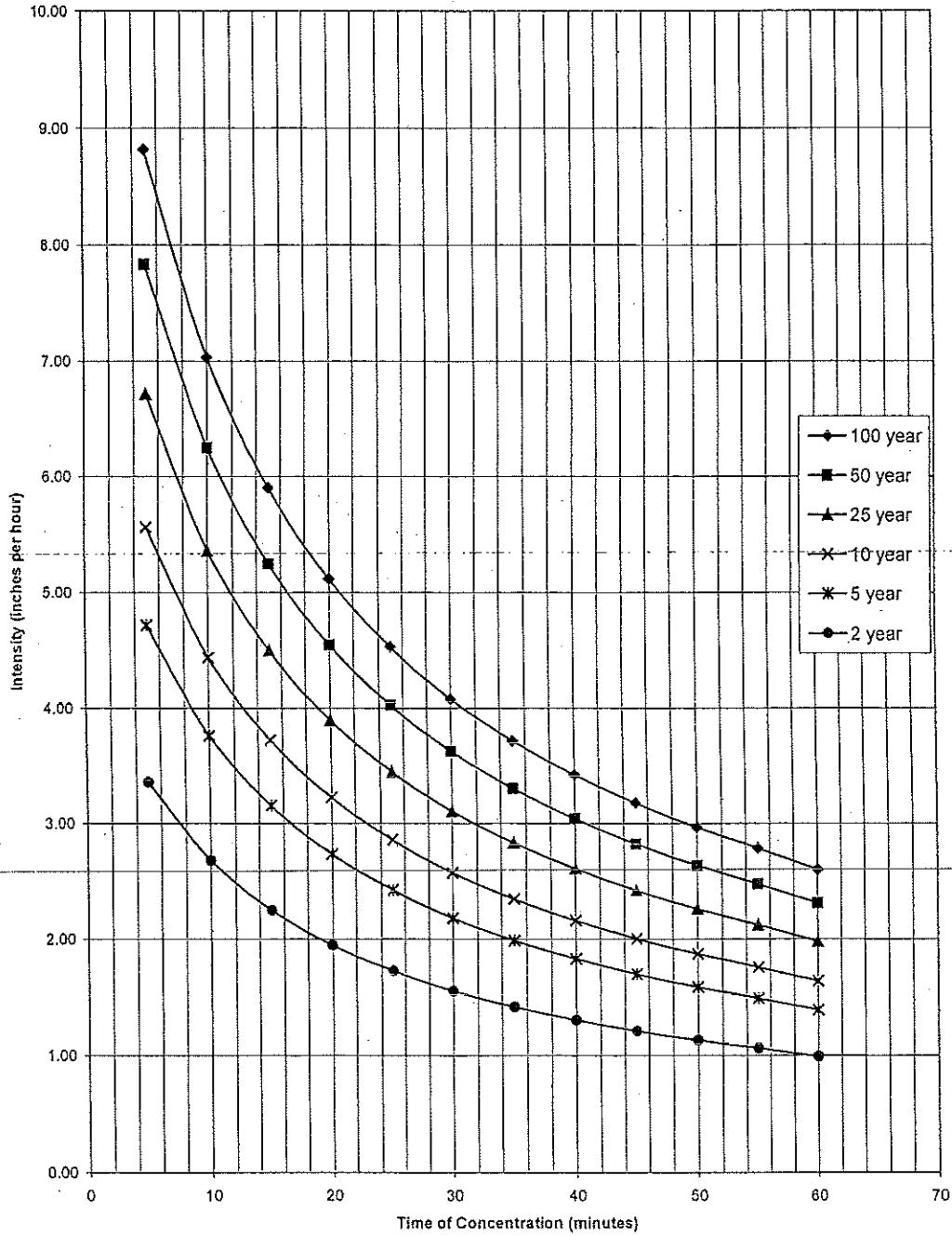

Figure 5.1 Rainfall Intensity Versus Duration Curves for Parker, Colorado

APPENDIX B
Hydraulic Calculations

Table 2.3

**RECURRENCE INTERVALS (years) FOR
INITIAL AND MAJOR STORM RUNOFF DESIGN**

Land use	Initial Storm	Major Storm
Residential	2	100
Open Space/Agricultural	2	100
School	2	100
Commercial/Business/Industrial	5	100

2.5.1 STREETS

Streets are an integral part of the urban drainage system and may be used for transporting storm runoff up to design limits. The design engineer should recognize that the primary purpose of streets is for traffic. Therefore, use of streets for storm runoff must be limited.

Although street criteria are formulated to allow certain drainage, streets should not routinely be considered as major drainageways. The Town of Parker, prohibits the practice of discharging offsite culverts and other non-local drainage outfalls onto streets. Storm drains should not outfall onto streets, but should be piped to suitable outfalls in a swale, channel, or detention basin. Street criteria should be applied to storm runoff flows emanating from building lots and other streets rather than discharges from major offsite drainageways flowing into streets.

Town of Parker criteria for allowable uses and depth of flow for initial and major storm runoff events is presented in Table 2.4, Table 2.5, and Table 2.6

Table 2.4

ALLOWABLE USE OF STREETS FOR INITIAL STORM RUNOFF

Street Classification	Maximum Theoretical Encroachment
Local	No curb overtopping. Flow may spread to crown of street.
Collector	No curb overtopping. Flow spread must leave at least a 10 foot width free of water.
Arterial	No curb overtopping. Flow spread must leave at least two lanes free of water, one 10 foot lane each direction.

Where no curbing exists, encroachment should not extend past the street right-of-way. The maximum allowable street flow shall be the product of the flow calculated at "maximum theoretical street encroachment" and required reduction factor. See Section 6.4

Parker Auto Plaza
Inlet Capacity Summary

Inlet	Location	Inlet Size	Inlet Condition	5yr Flow	5yr Flow Spread	100yr Flow + Carry Over to Inlet	100yr Inlet Capacity	100yr Flow Past Inlet	Downstream Inlet if Carry Over	Contributing Flows
1	Interior	10 ft	Sump			17.9 cfs	17.2 cfs	1 cfs		Basin 1A
2	Interior	15 ft	Sump			20.7 cfs	24.3 cfs	(4 cfs)		Basin 2A
3	Interior	10 ft	Sump			19.5 cfs	19.1 cfs	0 cfs		Basin 3A
4	Interior	10 ft	Sump			23.1 cfs	19.5 cfs	4 cfs		Basin 4A
10	20 Mile Rd	15 ft	Grade	1.9 cfs	7.3 ft	3.7 cfs	3.6 cfs	0 cfs	Off Site	Basin 1B
11	20 Mile Rd	10 ft	Grade	1.6 cfs	6.6 ft	3.8 cfs	3.0 cfs	1 cfs	Inlet 18	Basin 2B
12	Interior	10 ft	Sump			8.2 cfs	9.2 cfs	(1 cfs)		Basin 13B
13	Interior	10 ft	Sump			13.7 cfs	13.5 cfs	0 cfs		Basin 4B
14	Interior	10 ft	Sump			11.4 cfs	13.6 cfs	(2 cfs)		Basin 5B
15	Interior	5 ft	Sump			8.8 cfs	8.2 cfs	1 cfs	Detention Basin	Basin 6B
16	Dransfeldt	15 ft	Grade	2.1 cfs	5.5 ft	4.3 cfs	3.6 cfs	1 cfs	Inlet 27	1/2 Basin 7B
16a	Dransfeldt	15 ft	Grade	2.1 cfs	5.5 ft	4.3 cfs	3.6 cfs	1 cfs	Inlet 27	1/2 Basin 7B
17	Interior	15 ft	Sump			17.3 cfs	18.9 cfs	(2 cfs)		Basin 9B
18	20 Mile Rd	15 ft	Grade	3.5 cfs	12.3 ft	7.2 cfs	6.4 cfs	1 cfs	Off Site to the west	Basin 10B, Carry Inlet 11
19	Interior	10 ft	Sump			9.5 cfs	11.3 cfs	(2 cfs)		Basin 11B
20	Interior	10 ft	Sump			13.9 cfs	18.3 cfs	(4 cfs)		Basin 12B
21	Interior	10 ft	Sump			15.5 cfs	15.5 cfs	0 cfs		Basin 3B
25	20 Mile Rd	10 ft	Sump	2.8 cfs	9.1 ft	7.0 cfs	11.6 cfs	(5 cfs)		Basin 5C, Carry Inlet 27
26	20 Mile Rd	3.25 ft	Sump	1.7 cfs	6.9 ft	4.3 cfs	5.8 cfs	(2 cfs)		Basin 6C, Carry Inlet 27a
27	20 Mile Rd	10 ft	Grade	2.6 cfs	13.7 ft	5.9 cfs	3.4 cfs	3 cfs	Inlet 25	Basin 3C, Carry Inlet 16,16a
27a	20 Mile Rd	10 ft	Grade	2.3 cfs	10.9 ft	4.7 cfs	2.9 cfs	2 cfs	Inlet 26	Basin 4C
28	20 Mile Rd	5 ft	Grade	1.5 cfs	10.1 ft	3.1 cfs	1.6 cfs	2 cfs		Basin 2D
40	Parker Rd	5 ft	Sump	3.7 cfs	8.6 ft	7.3 cfs	6.2 cfs	1 cfs	Baldwin Gulch	Basin 7C

Town of Parker Criteria (Pg 6-15, Section 6.3.5): A 50% reduction factor should be used on carry over flows when determining the amount of flow entering a downstream inlet, due to Carry Over.

Table 2.4: Allowable Use of Streets for Initial Storm Runoff (5-year Runoff)

Collector: No curb overtopping. Flow spread must leave at least a 10-ft width free of water.

Dransfeldt Rd Maximum Flow Spread = 16.0 ft

Arterial: No curb overtopping. Flow spread must leave at least two lanes free of water, one 10-ft lane each direction.

Twenty Mile Rd Maximum Flow Spread = 17.0 ft

APPENDIX C
Detention Basin Calculations

Parker Auto Plaza
Detention Basin Calculations

WQCV = 0.45 inches
% Impervious(I) = 95 %

WQCV (Water Quality Capture Volume) taken from Fig. EDB-2, Volume 3 of the Urban Storm Drainage Criteria Manual for the basin imperviousness shown.
Percent Impervious taken from Table RO-3, Volume 1 of the Urban Storm Drainage Criteria Manual

WQCV = 0.045 * A
WQCV = WQCV/12 * A * 1.2
A = Area

Required Detention Storage Volume = $K_x A$

$K_{10} = 0.08835$
 $K_{100} = 0.14749$

$K_{10} = (0.95I - 1.9)/1000$
 $K_{100} = (1.78I - 0.002I^2 - 3.56)/1000$

Unit Flow Release Rate (cfs/acre)

Hydrologic Soil Group **B**
 $U_{10} = 0.23$
 $U_{100} = 0.85$

Basin	Total Acres	V_{10}		V_{100}		WQCV		10-yr Required Capacity		100-yr Required Capacity		Release Rate	
		ac-ft	cf	ac-ft	cf	ac-ft	cf	ac-ft	cf	ac-ft	cf	Q_{10}	Q_{100}
Detention Basin A	15.45 ac	1.37 ac-ft	59,460 cf	2.28 ac-ft	99,261 cf	0.70 ac-ft	30,285 cf	2.06 ac-ft	89,745 cf	2.97 ac-ft	129,546 cf	3.6 cfs	13.1 cfs
Detention Basin B	21.20 ac	1.87 ac-ft	81,589 cf	3.13 ac-ft	136,203 cf	0.95 ac-ft	41,556 cf	2.83 ac-ft	123,145 cf	4.08 ac-ft	177,759 cf	4.9 cfs	18.0 cfs

$V_x = K_x A$

Release Rate = Area * U_x

U_x = Recommended Maximum Allowable Unit Flow Release Rates (cfs/acre) of Tributary Catchment (Table SO-1, Urban Drainage and Flood Control District - Volume 2)

Parker Auto Plaza
Detention Basin Calculations

Presedimentation / Forebay Sizing

Detention Basin A

WQCV	30,285 cf
10% WQCV	3,029 cf
Orifice Eqn Coef. (C)	0.50

Forebay Pipe Number	Flow	% Total Flow	Weighted Forebay Area	Forebay Size			5 Minute Drain Flow	Pipes Out of Forebay - Orifice Calculation						Total Flow
				Depth	Surface Area	Semicirc. Radii		Pipe 1 Diameter	Pipe 1 Flow	Pipe 2 Diameter	Pipe 2 Flow	Pipe 3 Diameter	Pipe 3 Flow	
S2	37 cfs	46.84 %	1,418 cf	2.0 ft	709 sf	21 ft	4.7 cfs	8 inches	1.8 cfs	10 inches	2.8 cfs	0 inches	0.0 cfs	4.6 cfs
S3	19 cfs	24.05 %	728 cf	2.0 ft	364 sf	15 ft	2.4 cfs	6 inches	1.0 cfs	6 inches	1.0 cfs	0 inches	0.0 cfs	2.1 cfs
S4	23 cfs	29.11 %	882 cf	2.0 ft	441 sf	17 ft	2.9 cfs	6 inches	1.0 cfs	8 inches	1.8 cfs	0 inches	0.0 cfs	2.9 cfs
	79.0 cfs	100.00 %	3,029 cf											9.5 cfs

Orifice Equation:

$$Q = CA(2gH)^{0.5}$$

C = Orifice coefficient (dimensionless)

A = Cross-sectional area of opening, in sf

g = Gravitational acceleration constant, 32.2 ft/sec²

H = Head above the centerline of the pipe, in ft

Detention Basin B

WQCV	41,556 cf
10% WQCV	4,156 cf
Orifice Eqn Coef. (C)	0.50

Forebay Pipe Number	Flow	% Total Flow	Weighted Forebay Area	Forebay Size			5 Minute Drain Flow	Pipes Out of Forebay - Orifice Calculation						Total Flow
				Depth	Surface Area	Semicirc. Radii		Pipe 1 Diameter	Pipe 1 Flow	Pipe 2 Diameter	Pipe 2 Flow	Pipe 3 Diameter	Pipe 3 Flow	
S10	92 cfs	100.00 %	4,156 cf	2.0 ft	2,078 sf	36 ft	13.9 cfs	12 inches	3.9 cfs	12 inches	3.9 cfs	12 inches	3.9 cfs	11.6 cfs
	92.0 cfs	100.00 %	4,156 cf											11.6 cfs

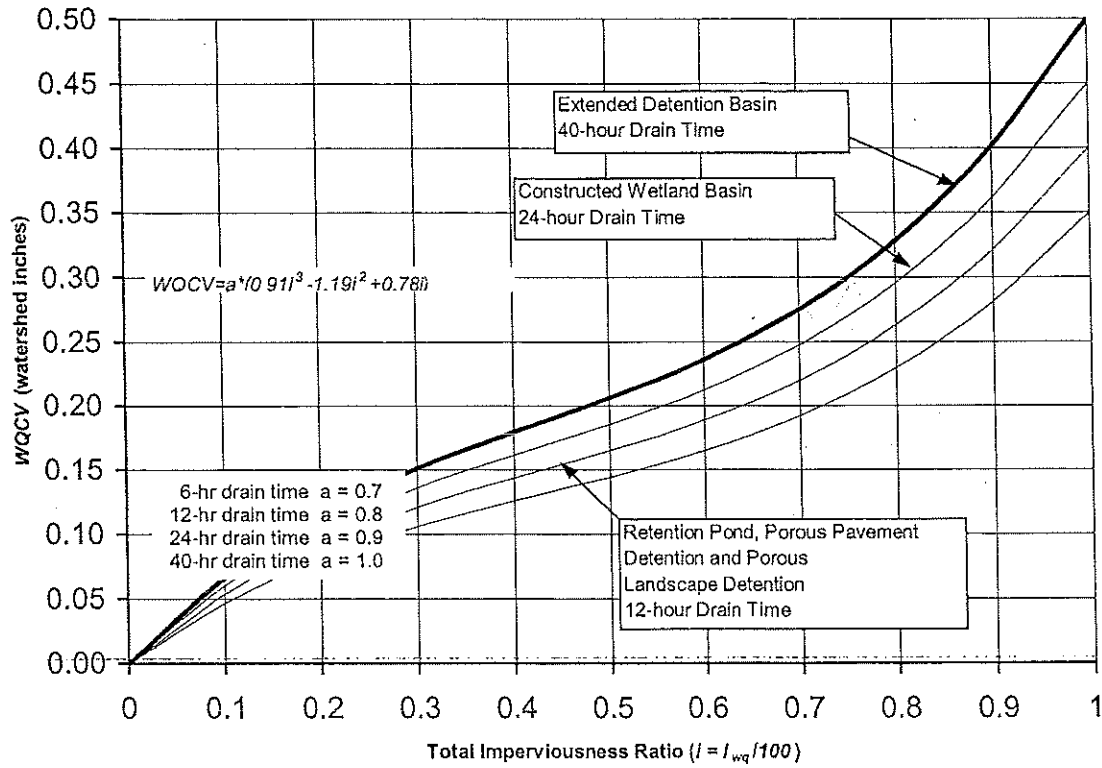

FIGURE EDB-2

Water Quality Capture Volume (WQCV), 80th Percentile Runoff Event

attempt to account for the effects of the WQCV on all control levels whenever it performs watershed-level drainage and flood control system master plans.

3.2 Sizing of On-Site Detention Facilities

3.2.1 Maximum Allowable Unit Release Rates for On-Site Facilities. The maximum allowable unit release rates per acre for on-site detention facilities for a number of design return periods are listed in Table SO-1. These rates apply unless other rates are recommended in a District-approved master plan.

The predominant soil group for the total tributary catchment shall be used for determining the allowable release rates. Multiply the unit rates provided in Table SO-1 by the tributary catchment's area to obtain the actual design release rates in cubic feet per second (cfs). Whenever Natural Resources Conservation Service (NRCS) soil surveys are not available for the portion of a county being studied, extrapolate their types using soil investigations at the site.

TABLE SO-1

Recommended Maximum Allowable Unit Flow Release Rates (cfs/acre) of Tributary Catchment

Design Return Period (Years)	NRCS Hydrologic Soil Group		
	A	B	C & D
2	0.02	0.03	0.04
5	0.07	0.13	0.17
10	0.13	0.23	0.30
25	0.24	0.41	0.52
50	0.33	0.56	0.68
100	0.50	0.85	1.00

3.2.2 Empirical Equations for the Sizing of On-Site Detention Storage Volumes. Urbonas and Glidden (1983), as part of the District's ongoing hydrologic research, conducted studies that evaluated peak storm runoff flows along major drainageways. The following set of empirical equations provided preliminary estimates of on-site detention facility sizing for areas within the District. They are not intended for use when off-site inflows are present or when multi-stage controls are to be used (e.g., 10- and 100-year peak control) at the storage facility. In addition, these equations are not intended to replace detailed hydrologic and flood routing analysis, or even the analysis using the Rational Formula-based FAA method for the sizing of detention storage volumes. The District does not promote the use of these empirical equations. It does not object, however, to their use by local governments who have adopted them or want to adopt them as minimum requirements for the sizing of on-site detention for small catchments within their jurisdiction. If the District has a master plan that contains specific guidance for detention

APPENDIX C.1
Detention Basin A Calculations

Parker Auto Plaza
Detention Basin Earthwork Calculation

Detention Basin A

Elevation	Area	Avg. Area	Volume	Basin Depth	Cumulative Basin Volume		Elevation
77.7	315 sf						
		448 sf	134 cf	0.3 ft	134 cf	0.003 ac-ft	78
78	580 sf						
		3,743 sf	3,743 cf	1.3 ft	3,877 cf	0.09 ac-ft	79
79	6,905 sf						
		13,299 sf	13,299 cf	2.3 ft	17,175 cf	0.39 ac-ft	80
80	19,692 sf						
		22,546 sf	22,546 cf	3.3 ft	39,721 cf	0.91 ac-ft	81
81	25,400 sf						
		27,000 sf	27,000 cf	4.3 ft	66,721 cf	1.53 ac-ft	82
82	28,600 sf						
		30,125 sf	30,125 cf	5.3 ft	96,846 cf	2.22 ac-ft	83
83	31,650 sf						
		33,225 sf	33,225 cf	6.3 ft	130,071 cf	2.99 ac-ft	84
84	34,800 sf						
		36,075 sf	36,075 cf	7.3 ft	166,146 cf	3.81 ac-ft	85
85	37,350 sf						

Water Quality Capture Volume = 30,285 cf
WQCV Elevation = 80.58 ft

10yr Water Volume = 89,745 cf
10yr Water Surface Elevation = 82.76 ft

100yr Water Volume = 129,546 cf
100yr Water Surface Elevation = 83.98 ft

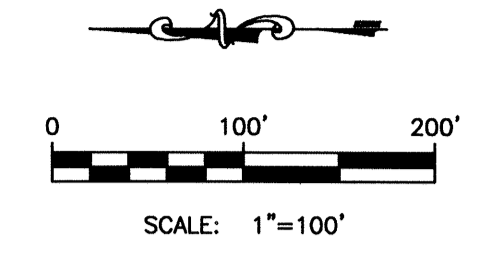
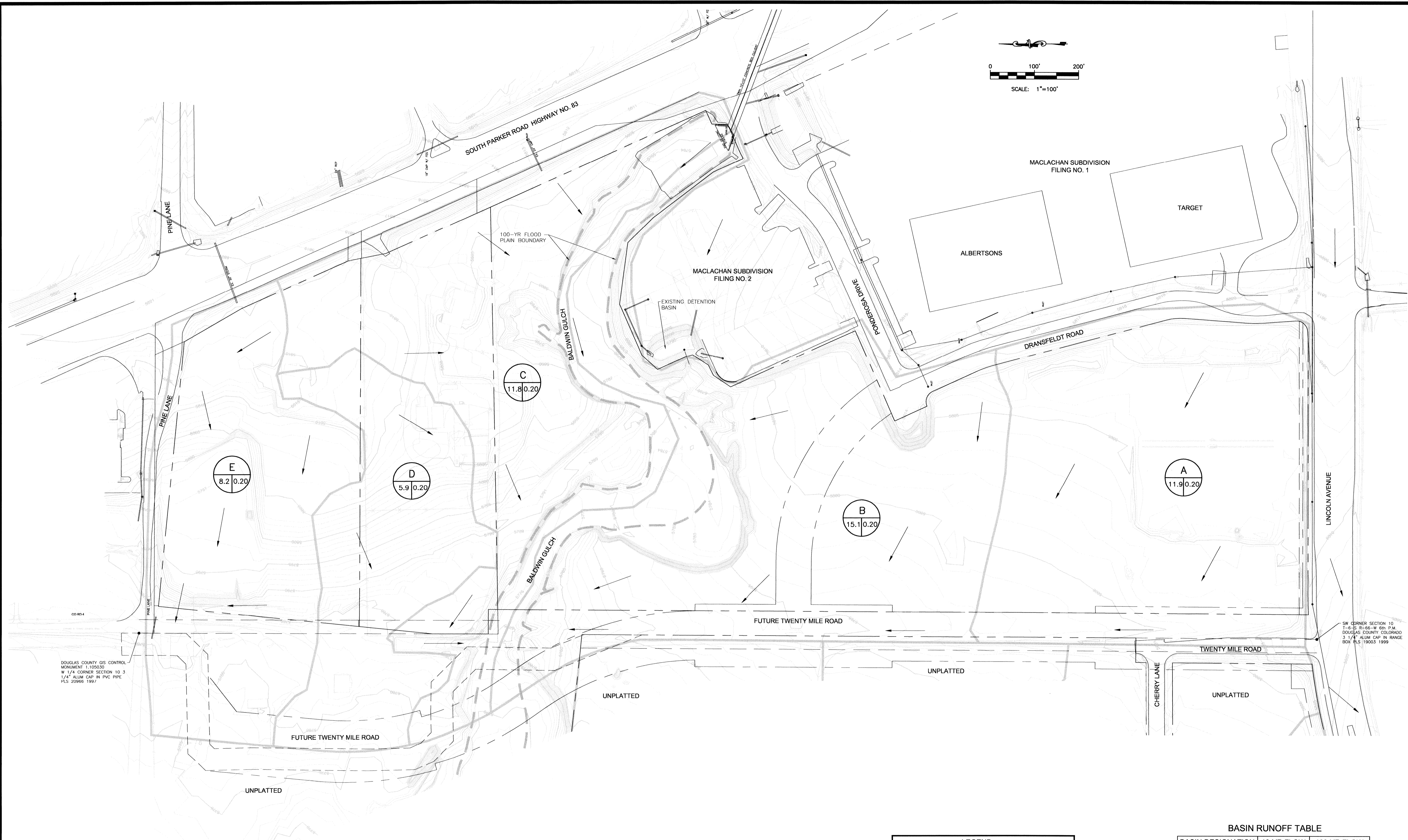

DOUGLAS COUNTY GIS CONTROL
MONUMENT 1.105030
W 1/4 CORNER SECTION 10 3
1/4" ALUM COP IN PVC PIPE
P.L.S. 20966 1997

SW CORNER SECTION 10
T-4-S R-46-W 6th P.M.
DOUGLAS COUNTY COLORADO
3 1/4" ALUM COP IN RANGE
BOX P.L.S. 19003 1999

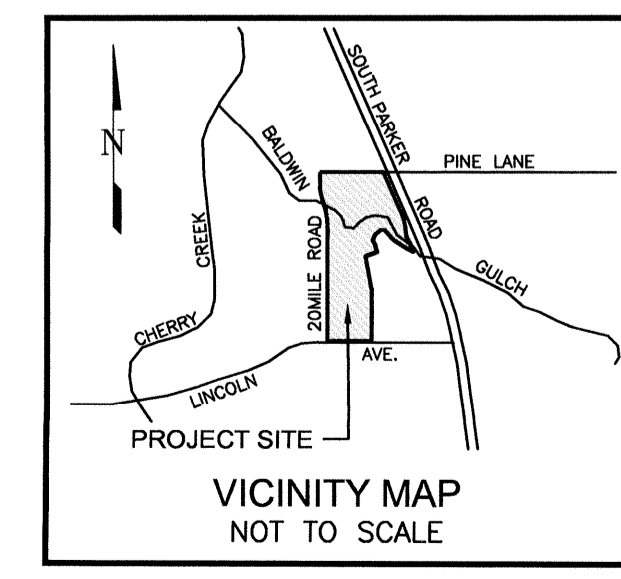

PROJECT DATUM: ALL ELEVATIONS ARE REFERENCED TO NAVD 88
AS SHOWN ON THE 1998 DOUGLAS COUNTY TABULATION

LEGEND	
	BASIN DESIGNATION
	BASIN AREA (AC) / C100 RUNOFF COEFFICIENT
	DIRECTIONAL FLOW ARROW
	EXISTING DRAINAGE BASIN BOUNDARY
	R.O.W. / PROPERTY LINE

BASIN RUNOFF TABLE		
BASIN DESIGNATION	10-YR FLOW	100-YR FLOW
A	1.1 cfs	7.0 cfs
B	1.7 cfs	10.8 cfs
C	1.1 cfs	6.9 cfs
D	0.7 cfs	4.6 cfs
E	0.9 cfs	5.7 cfs

Kiowa Engineering Corporation
7175 West Jefferson Avenue, Suite 3400
Lakewood, Colorado 80235
(303) 692-0369

PARKER AUTO PLAZA
EXISTING DRAINAGE PATTERNS
FINAL DRAINAGE REPORT
PARKER, COLORADO

Project No.: 00056
Date: July 12, 2004
Design: MWE
Drawn: MWE
Check: RNW
Revisions:

FIGURE
1

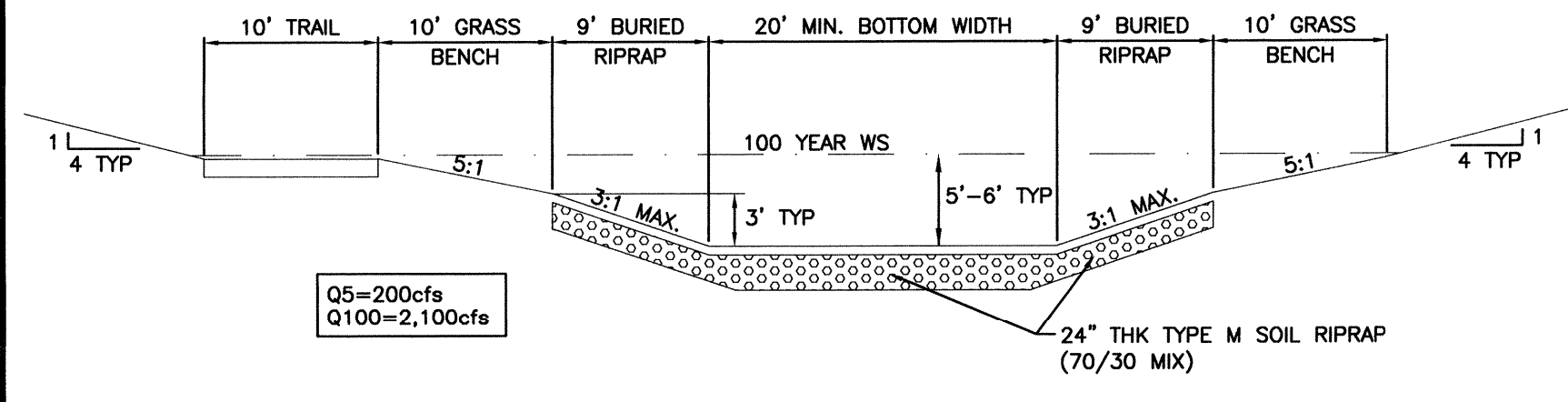
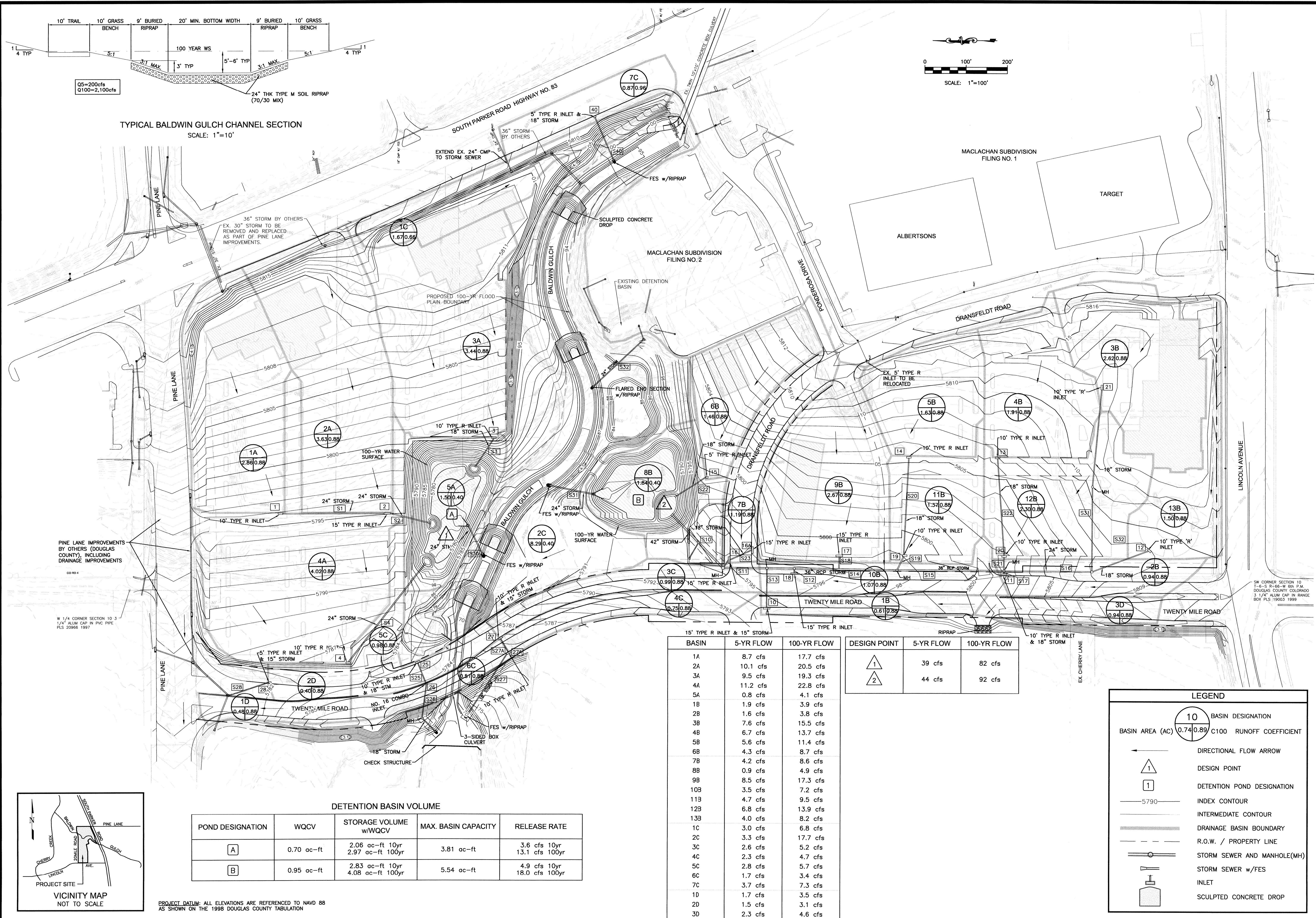

TYPICAL BALDWIN GULCH CHANNEL SECTION
SCALE: 1"=10'

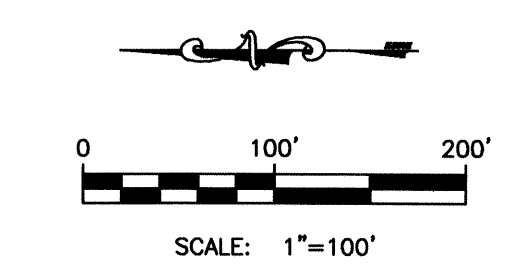

PINE LANE IMPROVEMENTS BY OTHERS (DOUGLAS COUNTY), INCLUDING DRAINAGE IMPROVEMENTS
00 RD 4

W 1/4 CORNER SECTION 10 3
1/4\"/>

SW CORNER SECTION 10
7-6-5 10-66-W 9th P.M.
DOUGLAS COUNTY COLORADO
S. 1/4\"/>

DETENTION BASIN VOLUME

POND DESIGNATION	WQCV	STORAGE VOLUME w/WQCV	MAX. BASIN CAPACITY	RELEASE RATE
A	0.70 ac-ft	2.06 ac-ft 10yr 2.97 ac-ft 100yr	3.81 ac-ft	3.6 cfs 10yr 13.1 cfs 100yr
B	0.95 ac-ft	2.83 ac-ft 10yr 4.08 ac-ft 100yr	5.54 ac-ft	4.9 cfs 10yr 18.0 cfs 100yr

BASIN	5-YR FLOW	100-YR FLOW	DESIGN POINT	5-YR FLOW	100-YR FLOW
1A	8.7 cfs	17.7 cfs	1	39 cfs	82 cfs
2A	10.1 cfs	20.5 cfs			
3A	9.5 cfs	19.3 cfs	2	44 cfs	92 cfs
4A	11.2 cfs	22.8 cfs			
5A	0.8 cfs	4.1 cfs			
1B	1.9 cfs	3.9 cfs			
2B	1.6 cfs	3.8 cfs			
3B	7.6 cfs	15.5 cfs			
4B	6.7 cfs	13.7 cfs			
5B	5.6 cfs	11.4 cfs			
6B	4.3 cfs	8.7 cfs			
7B	4.2 cfs	8.6 cfs			
8B	0.9 cfs	4.9 cfs			
9B	8.5 cfs	17.3 cfs			
10B	3.5 cfs	7.2 cfs			
11B	4.7 cfs	9.5 cfs			
12B	6.8 cfs	13.9 cfs			
13B	4.0 cfs	8.2 cfs			
1C	3.0 cfs	6.8 cfs			
2C	3.3 cfs	17.7 cfs			
3C	2.6 cfs	5.2 cfs			
4C	2.3 cfs	4.7 cfs			
5C	2.8 cfs	5.7 cfs			
6C	1.7 cfs	3.4 cfs			
7C	3.7 cfs	7.3 cfs			
1D	1.7 cfs	3.5 cfs			
2D	1.5 cfs	3.1 cfs			
3D	2.3 cfs	4.6 cfs			

LEGEND

10 BASIN DESIGNATION
BASIN AREA (AC) 0.74|0.89 C100 RUNOFF COEFFICIENT

→ DIRECTIONAL FLOW ARROW

△ 1 DESIGN POINT

□ 1 DETENTION POND DESIGNATION

—5790— INDEX CONTOUR

--- INTERMEDIATE CONTOUR

--- DRAINAGE BASIN BOUNDARY

- - - R.O.W. / PROPERTY LINE

—○— STORM SEWER AND MANHOLE(MH)

—|— STORM SEWER w/FES

—|— INLET

—|— SCULPTED CONCRETE DROP

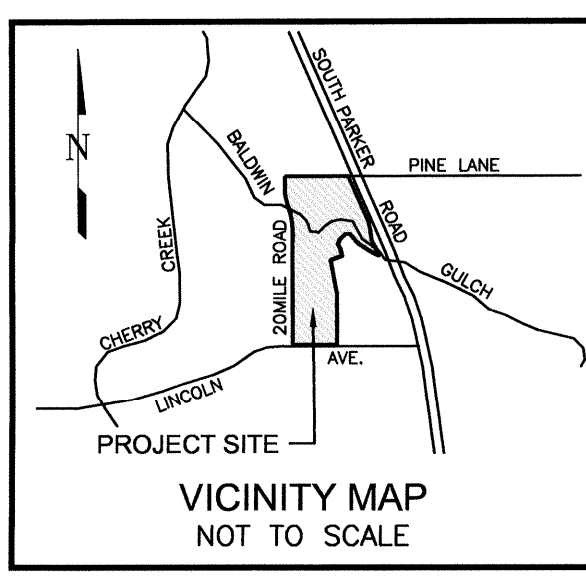

PROJECT DATUM: ALL ELEVATIONS ARE REFERENCED TO NAVD 88 AS SHOWN ON THE 1998 DOUGLAS COUNTY TABULATION

Kiowa Engineering Corporation
7175 West Jefferson Avenue, Suite 3400
Lakewood, Colorado 80235
(303) 692-0369

**PARKER AUTO PLAZA
DEVELOPED DRAINAGE PATTERNS
FINAL DRAINAGE REPORT
PARKER, COLORADO**

Project No.: 00056
Date: July 12, 2004
Design: MWE
Drawn: MWE
Check: RNW
Revisions:

FIGURE
2

K:\DENV_Civil\096502001 - Mt. Les. Parker. R\A\CADD\Plan\Sheet\096502001ST_DET.dwg, CASSIDY, Sheets: 10/16/2019, 10:57 AM
 THIS DOCUMENT, TOGETHER WITH THE CONCRETS AND DESIGNS PRESENTED HEREIN, AS AN INSTRUMENT OF SERVICE, IS INTENDED ONLY FOR THE SPECIFIC PROJECT AND SIGHT FOR WHICH IT WAS PREPARED. REVIEW OF AND IMPROPER RELIANCE ON THIS DOCUMENT WITHOUT WRITTEN AUTHORIZATION AND ADAPTATION BY KIMLEY-HORN AND ASSOCIATES, INC. SHALL BE WITHOUT LIABILITY TO KIMLEY-HORN AND ASSOCIATES, INC.

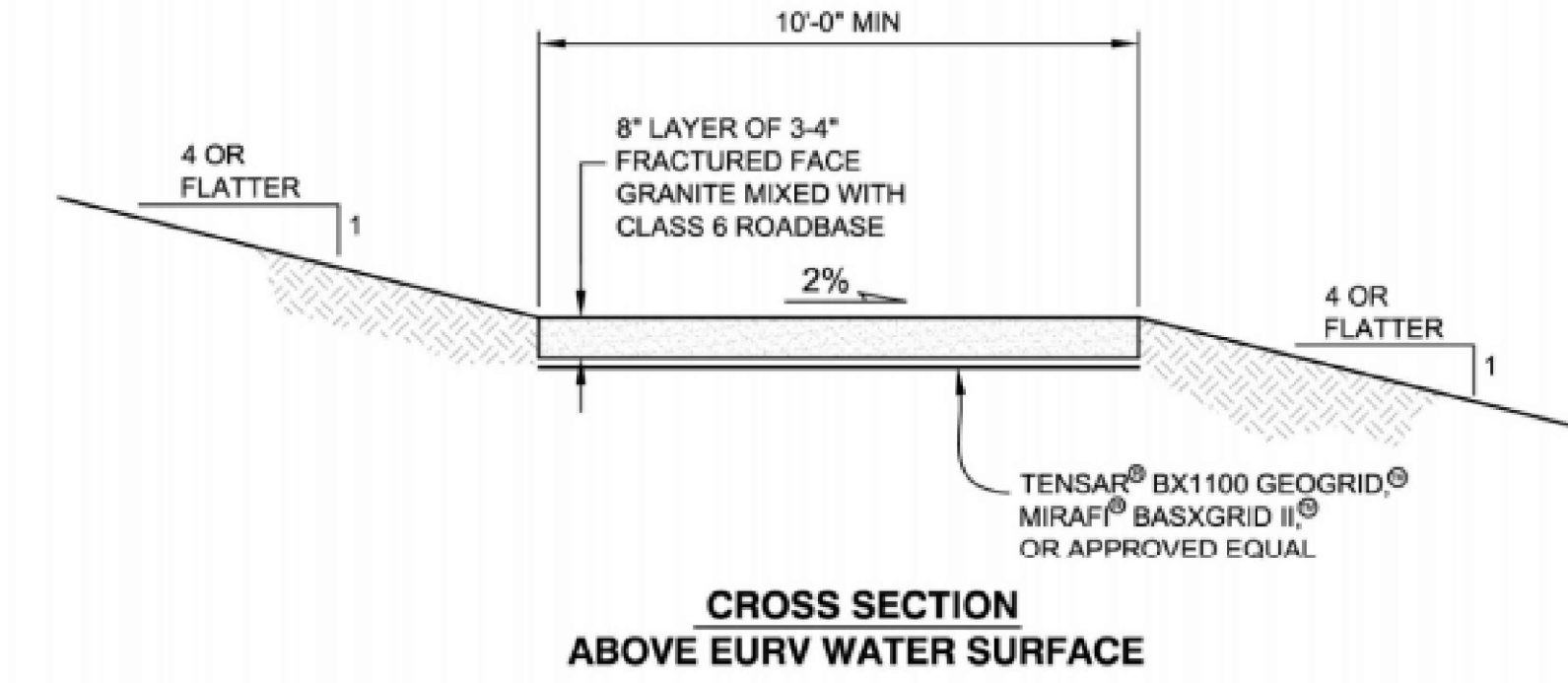
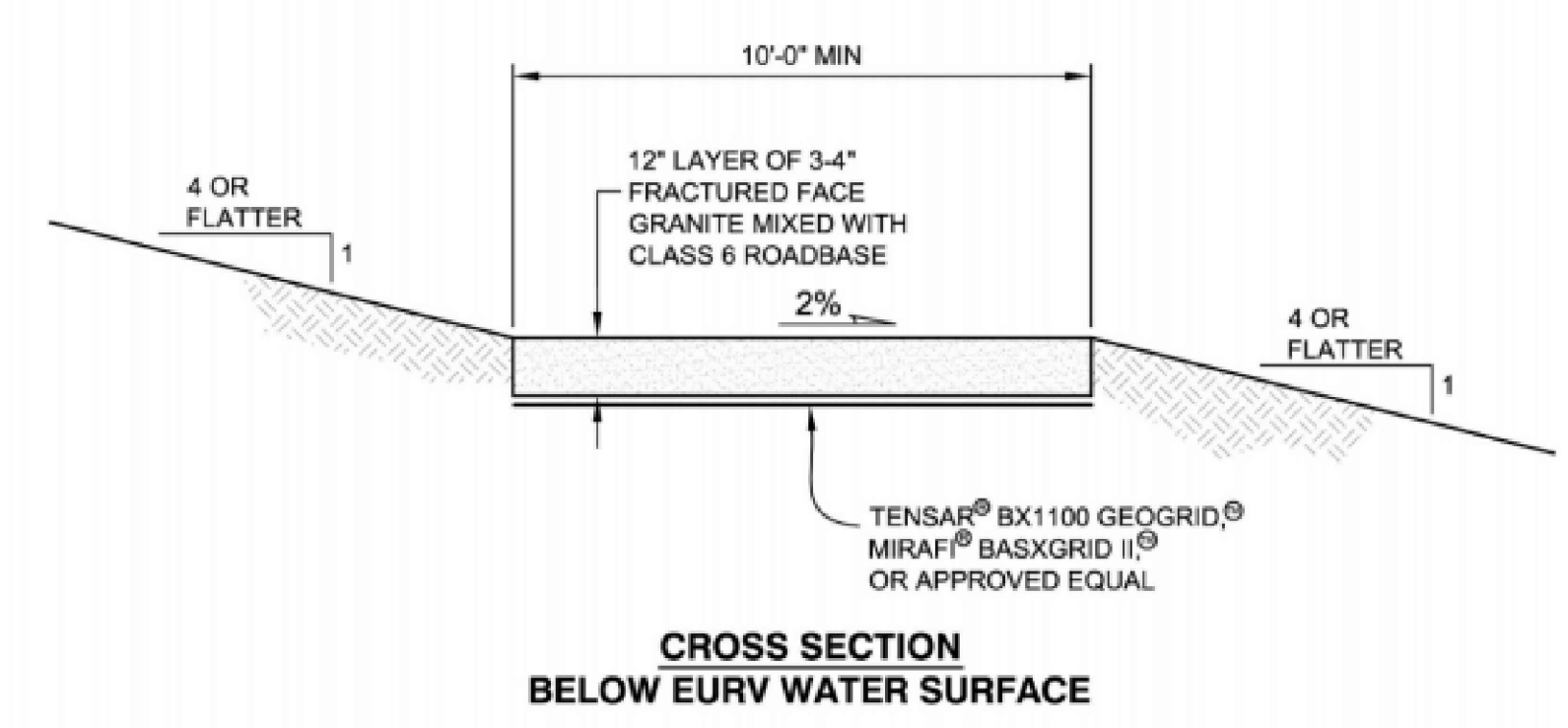
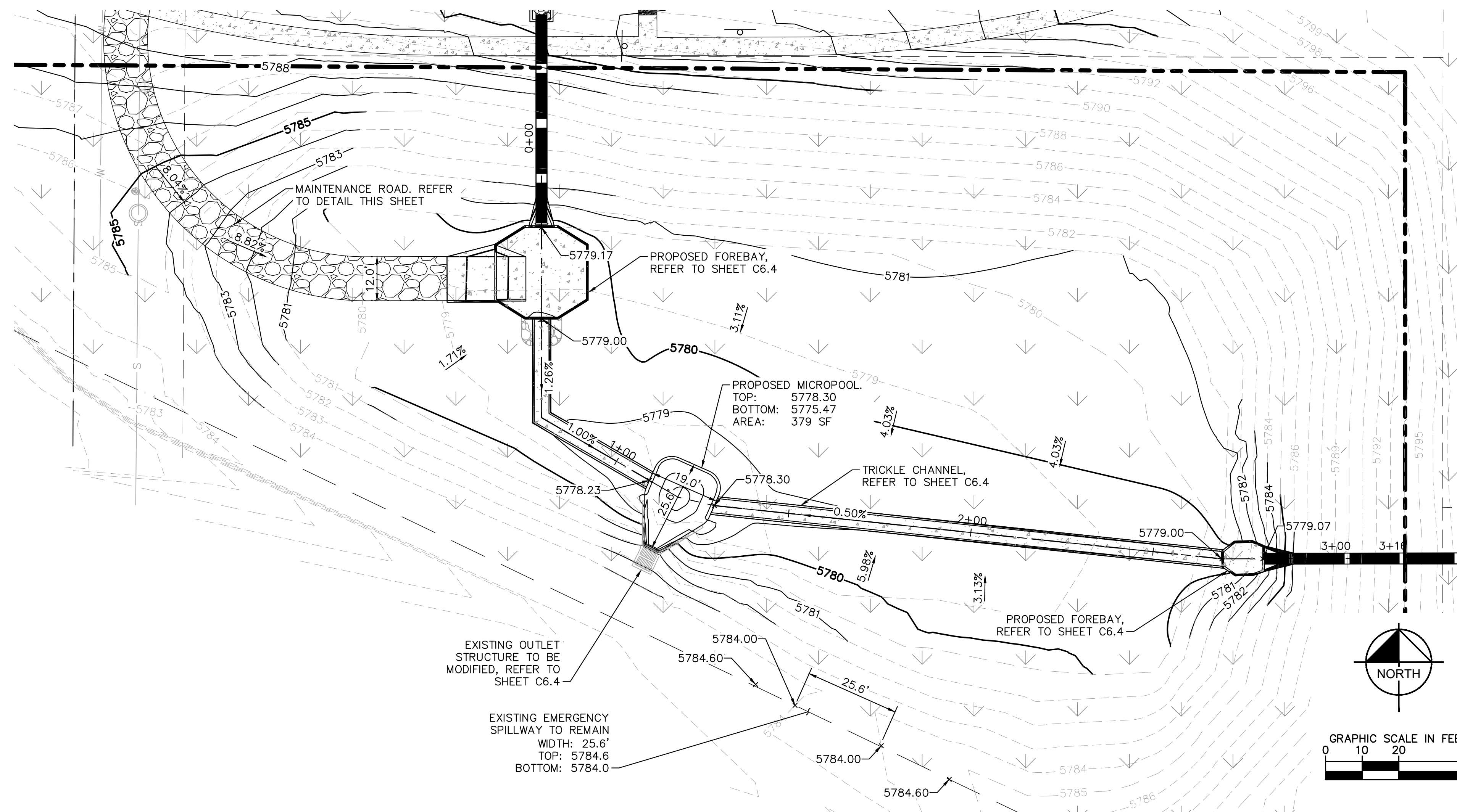

MAINTENANCE ROAD DETAILS
N.T.S.

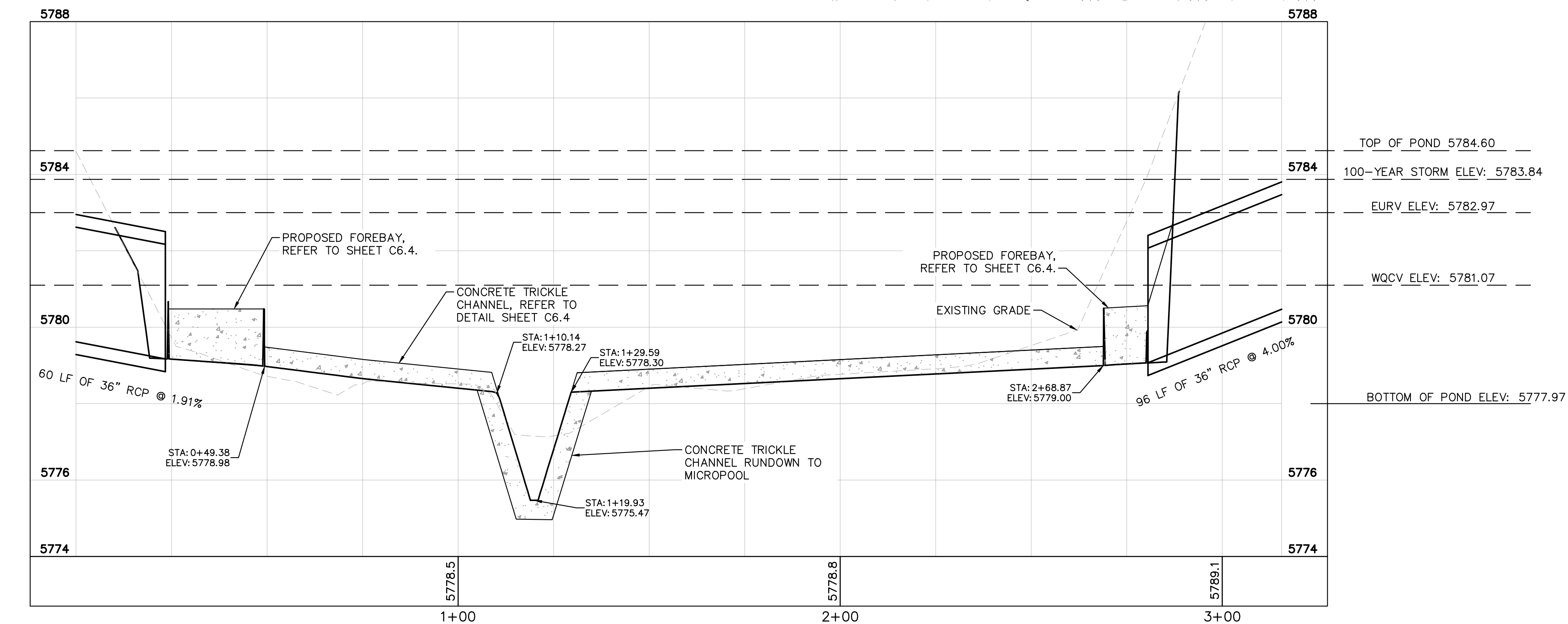

POND PROFILE
HORIZONTAL SCALE: 1" = 20'
VERTICAL SCALE: 1" = 2'

NO.	REVISION	BY	DATE	APPR

Kimley»Horn
 2020 KIMLEY-HORN AND ASSOCIATES, INC.
 4582 South Ulster Street, Suite 1500
 Denver, Colorado 80237 (303) 228-2300

DESIGNED BY: DLS
 DRAWN BY: ECZ
 CHECKED BY: DLS
 DATE: 03/11/20

PARKER & PINE MINOR DEVELOPMENT FILING NO. 1
 PARKER, CO
 CONSTRUCTION DOCUMENTS
 POND PLANS AND PROFILE

PRELIMINARY
 FOR REVIEW ONLY
 NOT FOR
 CONSTRUCTION
Kimley»Horn
 Kimley-Horn and Associates, Inc.

PROJECT NO.
096502001
 DRAWING NAME
096502001ST_DET
C6.3



K:\DEN_Civil\096502001 - Mid. Use, Parker, RA\CADD\Plan\Sheet\096502001_DET.dwg, CASSIDY, Sheets: 10/16/2010, 10:57 AM
 THIS DOCUMENT, WHETHER WITH THE CONCEPTS AND DESIGNS PRESENTED HEREIN, AS AN INSTRUMENT OF SERVICE, IS THE PROPERTY OF KIMLEY-HORN AND ASSOCIATES, INC. IT IS TO BE USED ONLY FOR THE PROJECT AND SITE SPECIFICALLY IDENTIFIED HEREIN. IT IS NOT TO BE REPRODUCED, COPIED, OR TRANSMITTED IN ANY FORM OR BY ANY MEANS, ELECTRONIC OR MECHANICAL, INCLUDING PHOTOCOPYING, RECORDING, OR BY ANY INFORMATION STORAGE AND RETRIEVAL SYSTEM, WITHOUT THE WRITTEN AUTHORIZATION AND ADAPTATION BY KIMLEY-HORN AND ASSOCIATES, INC. SHALL BE WITHOUT LIABILITY TO KIMLEY-HORN AND ASSOCIATES, INC.

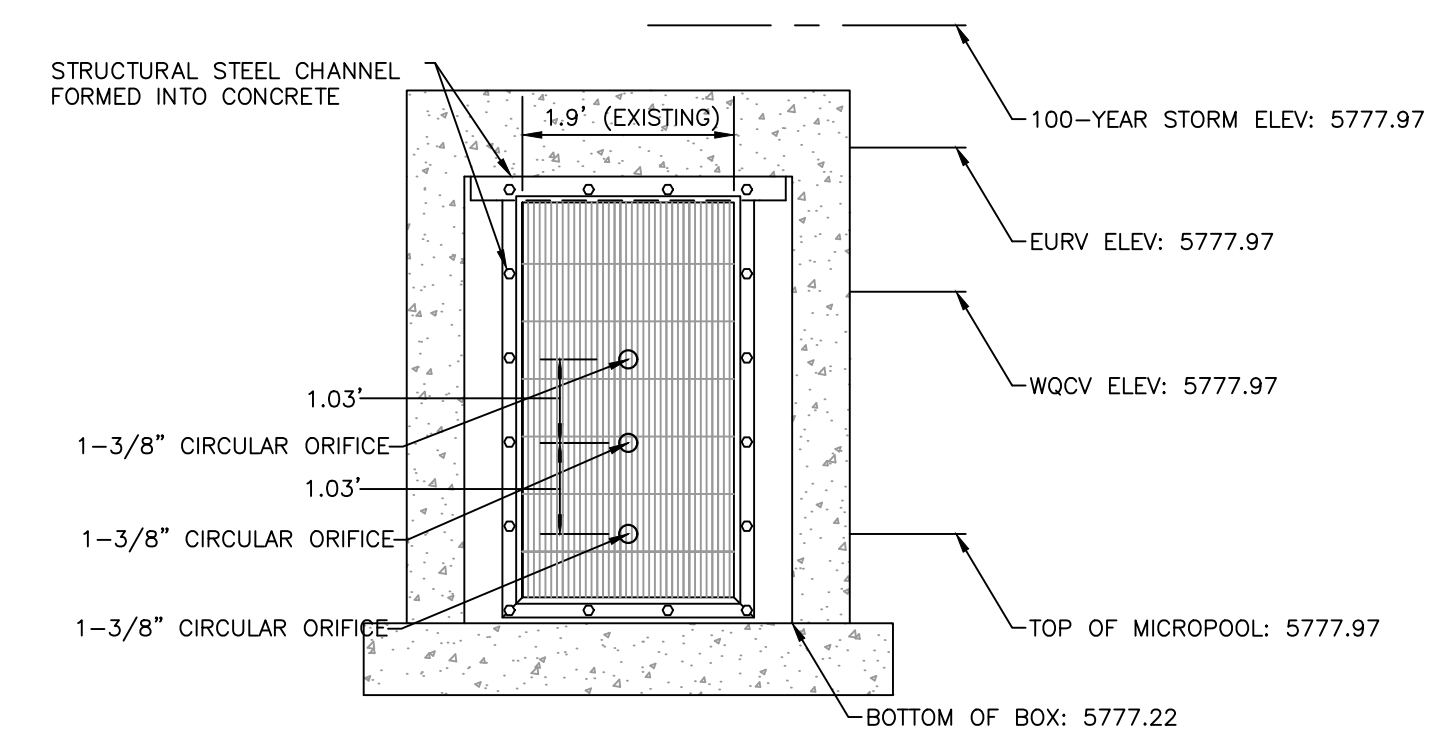
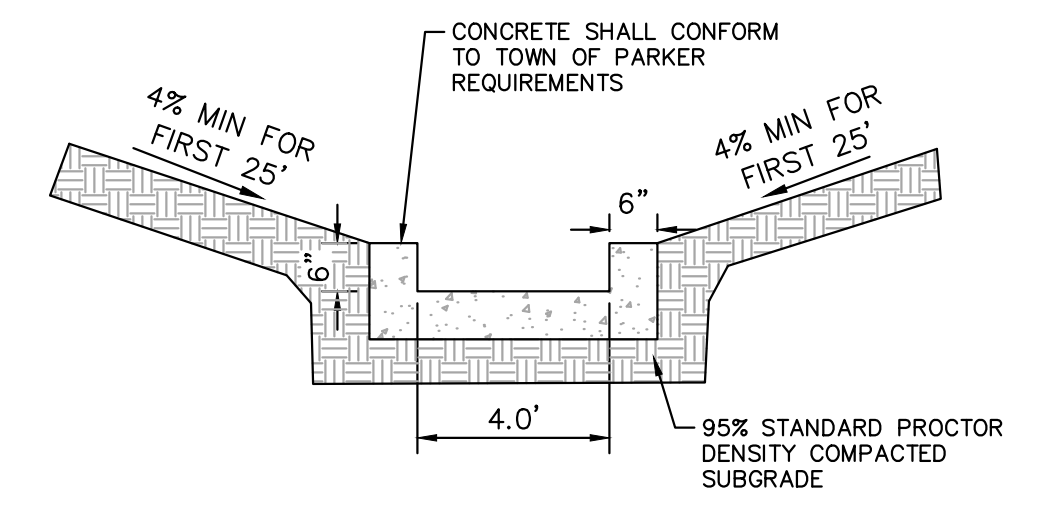
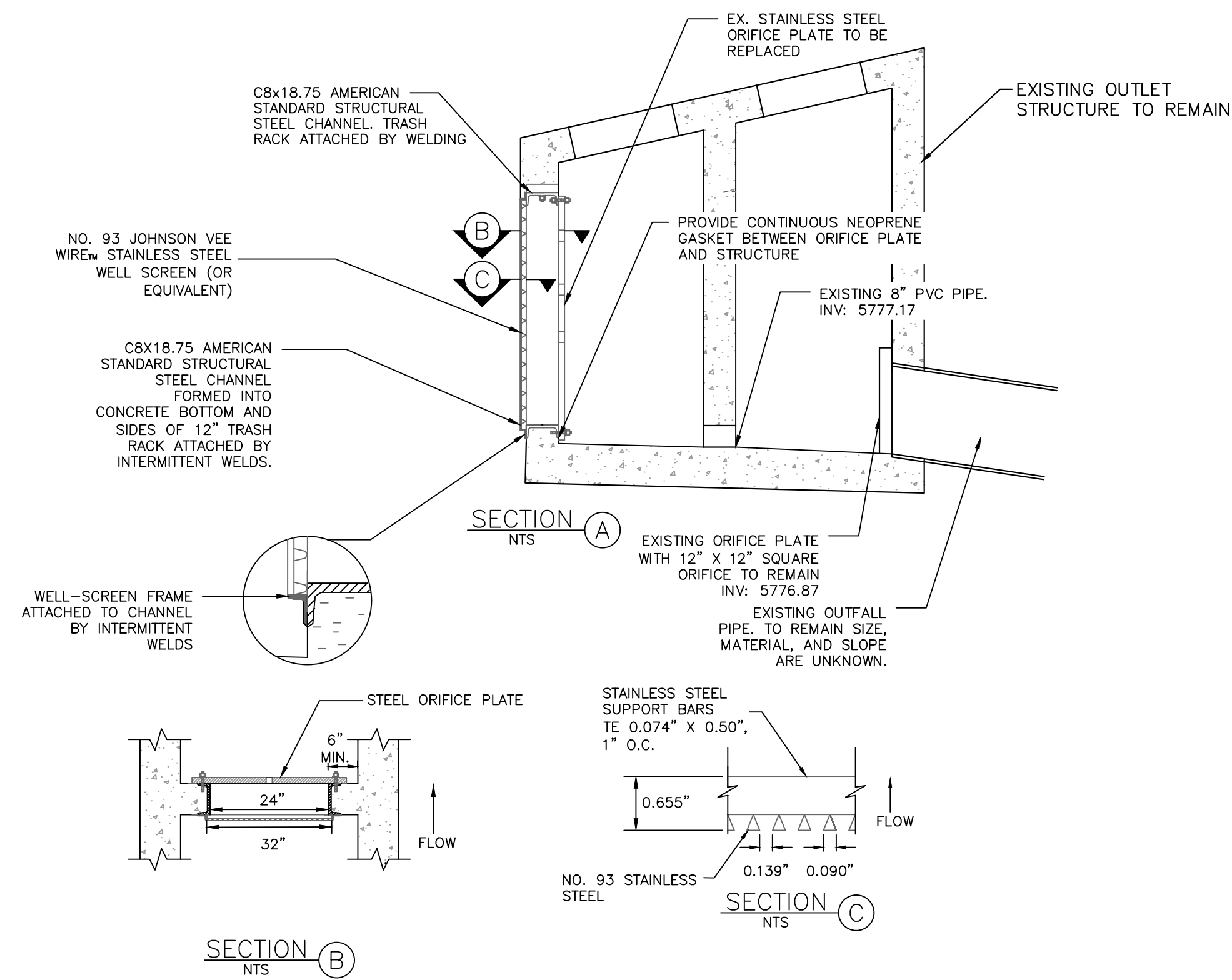
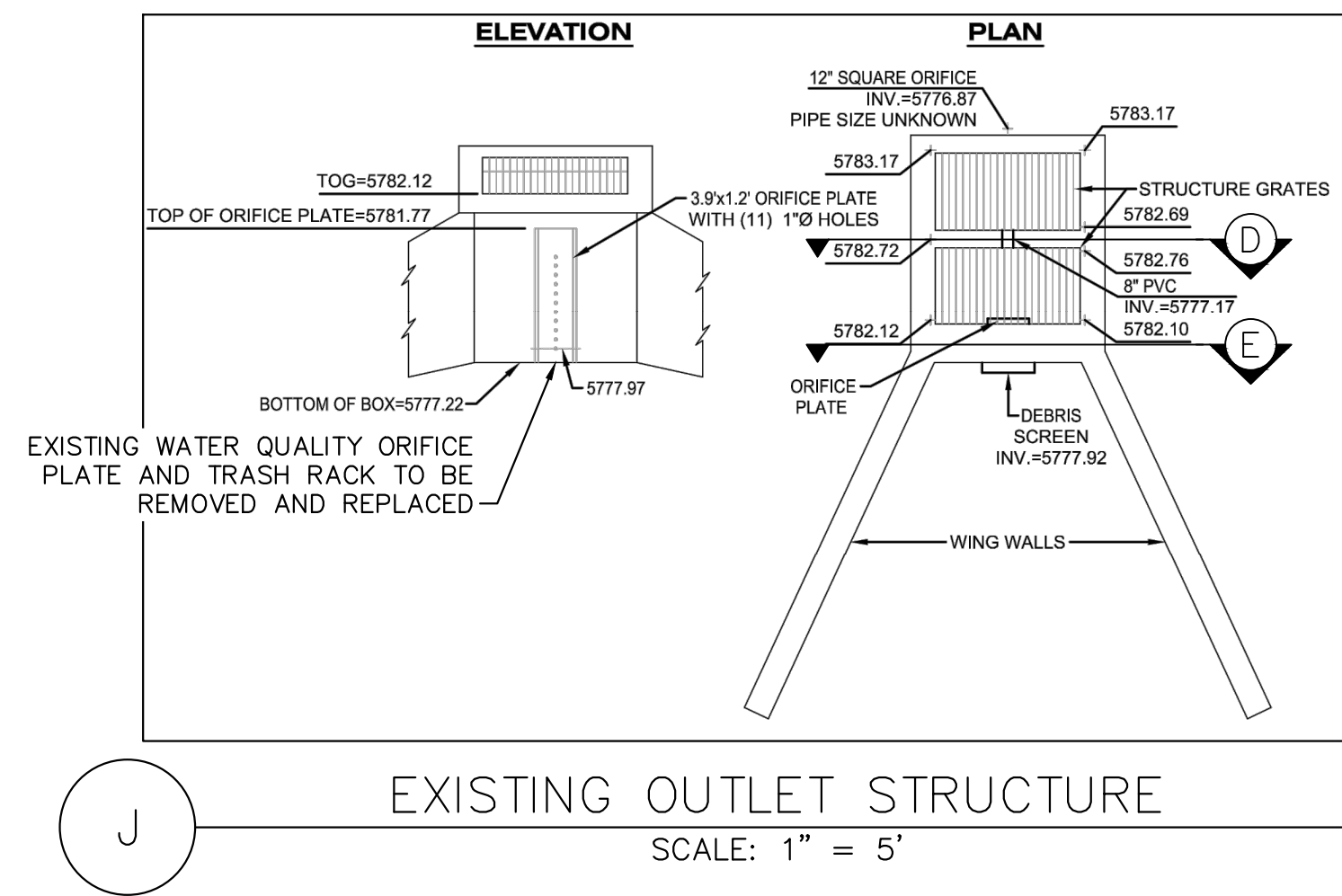

ORIFICE PLATE NOTES:

1. PROVIDE CONTINUOUS NEOPRENE GASKET MATERIAL BETWEEN THE ORIFICE PLATE AND THE CONCRETE.
2. BOLT PLATE TO CONCRETE 12" MAX ON CENTER.

EURV AND WQCV TRASH RACKS

1. WELL-SCREEN TRASH RACKS SHALL BE STAINLESS STEEL AND SHALL BE ATTACHED BY INTERMITTENT WELDS ALONG THE EDGE OF THE MOUNTING FRAME.
2. BAR GATE TRASH RACKS SHALL BE ALUMINUM AND SHALL BE BOLTED USING STAINLESS STEEL HARDWARE.
3. TRASH RACK OPEN AREAS ARE FOR SPECIFIED TRASH RACK MATERIALS. TOTAL TRASH RACK SIZE MAY NEED TO BE ADJUSTED FOR MATERIALS HAVING DIFFERENT OPEN AREA/GROSS AREA RATIO.
4. STRUCTURAL DESIGN OF TRASH RACKS SHALL BE BASED ON FULL HYDROSTATIC HEAD WITH ZERO HEAD DOWNSTREAM OF THE RACK.

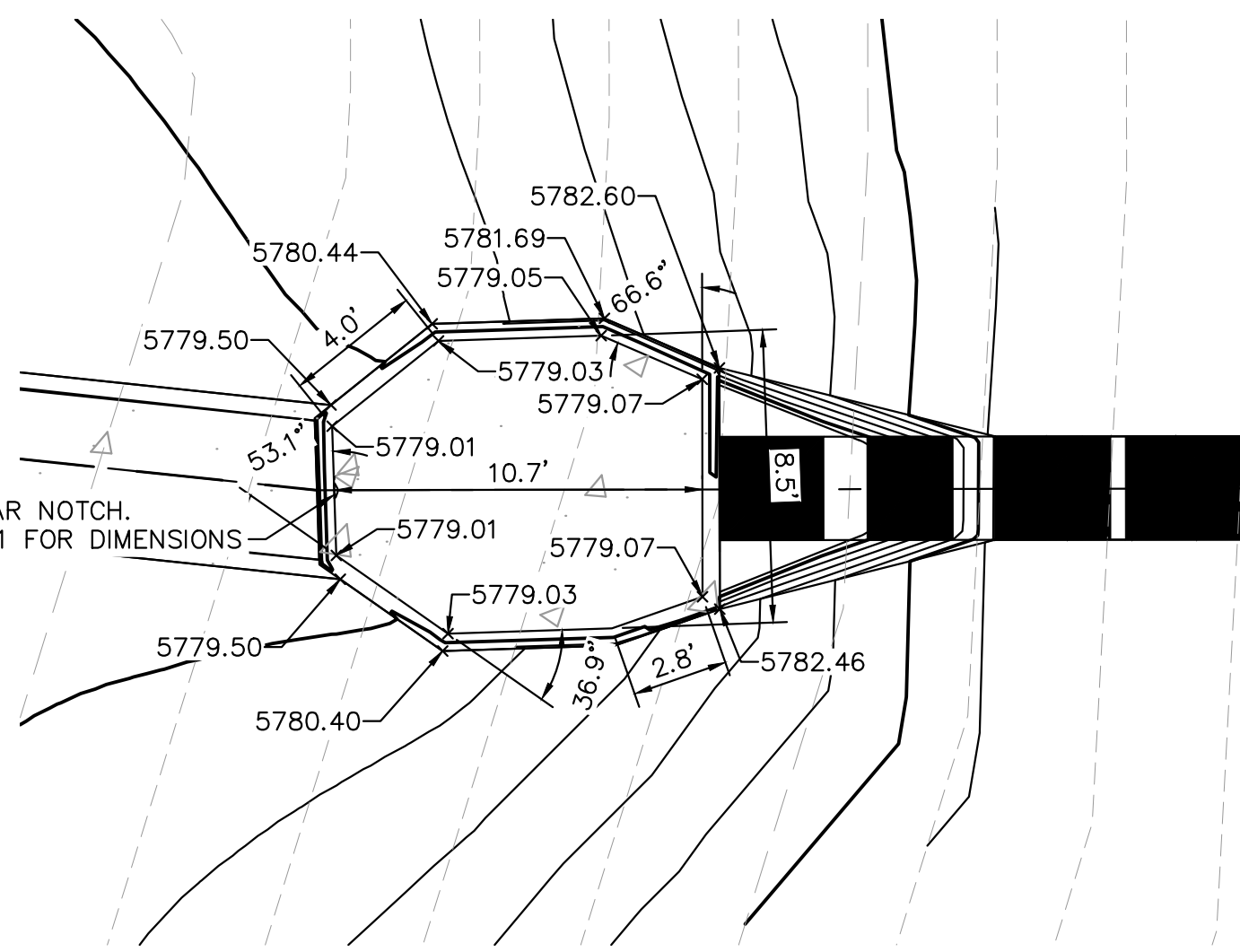
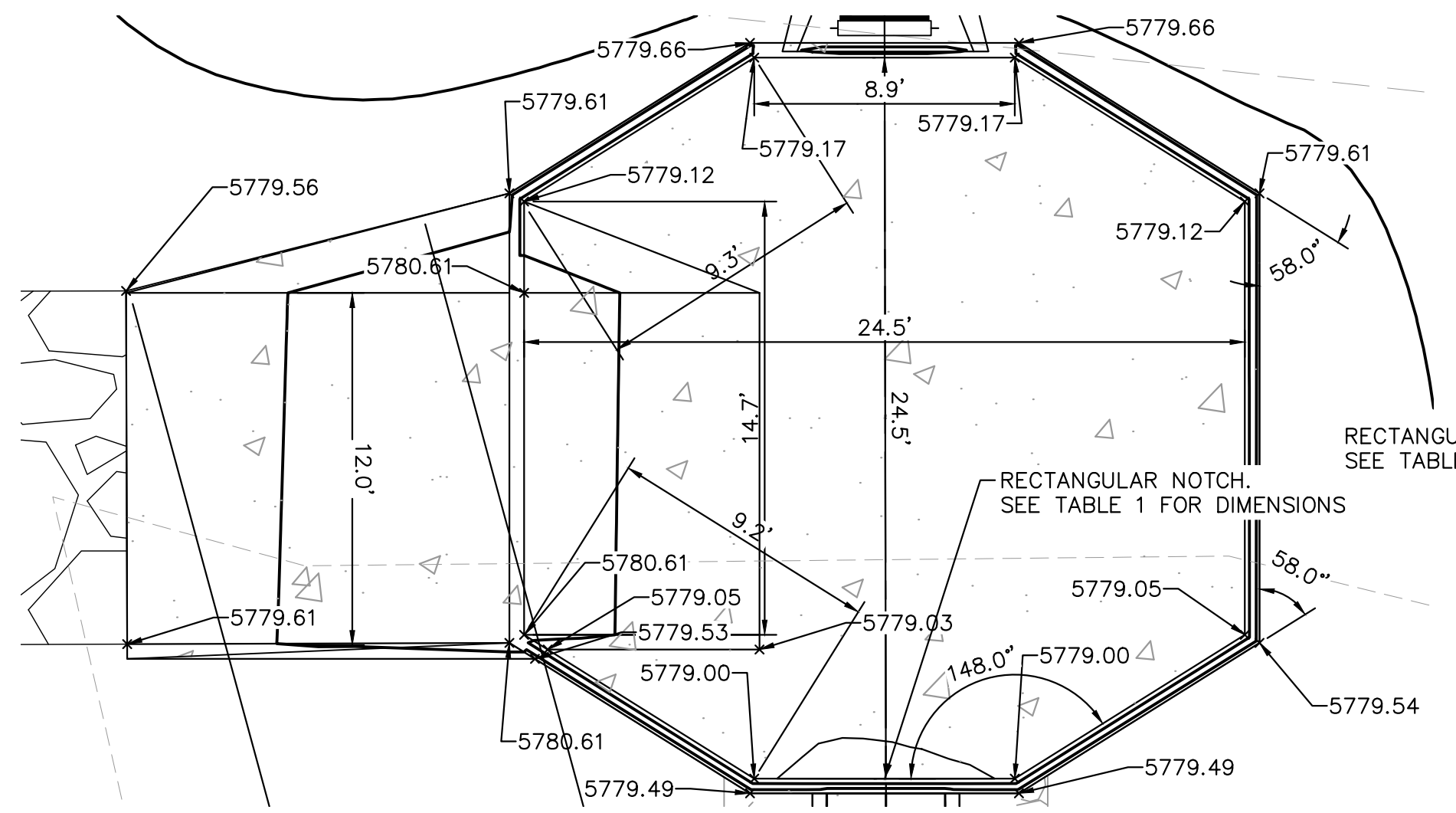
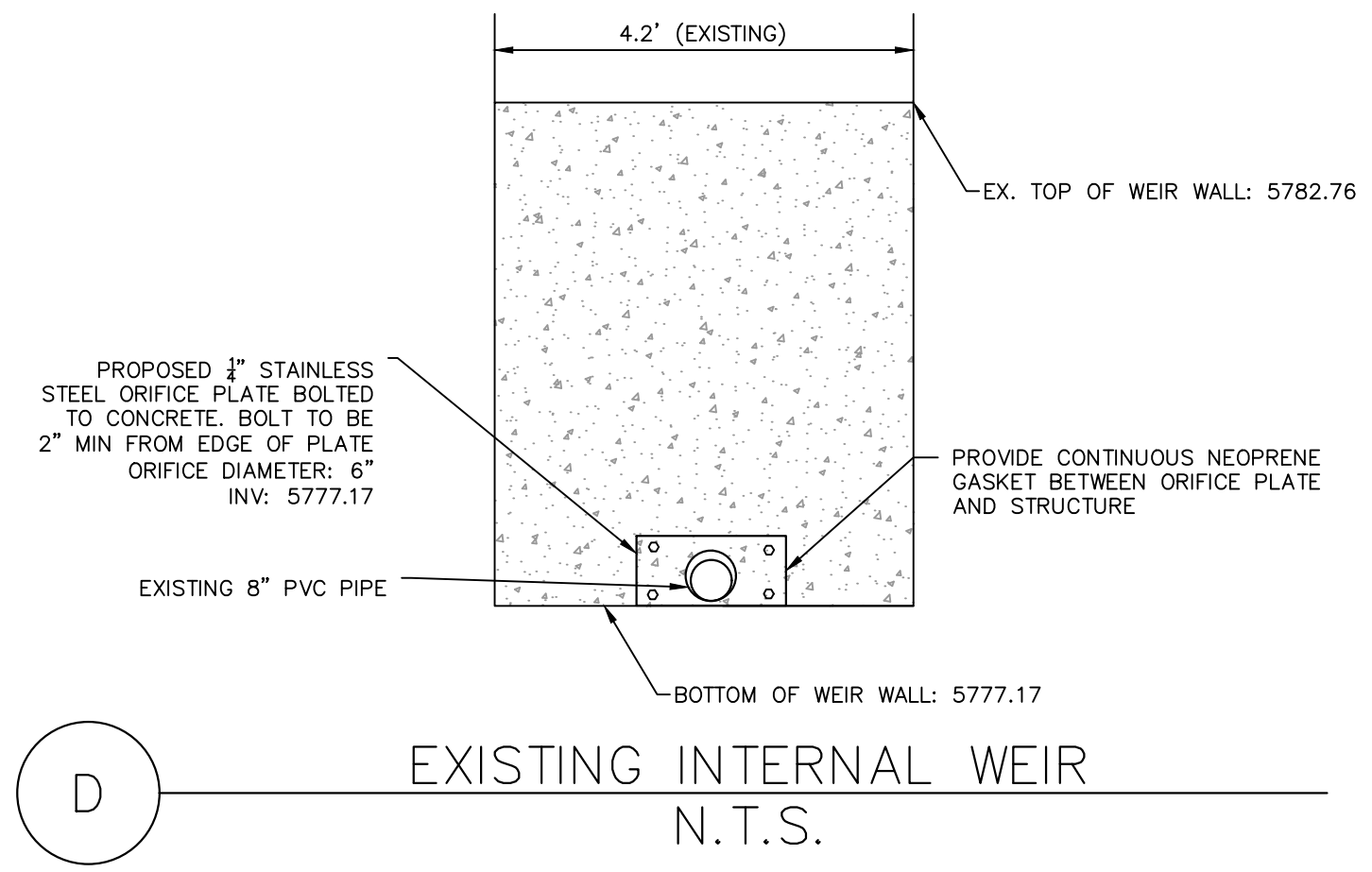

TABLE 1

Forebay ID	WATERSHED AREA (AC)	WQCV (CF)	REQUIRED VOLUME (CF)	FOREBAY SIZE (SF)	REQUIRED HEIGHT (INCHES)	PROVIDED HEIGHT (INCHES)	Q ₁₀₀ (cfs)	REQUIRED RELEASE RATE (cfs)	REQUIRED NOTCH WIDTH (INCHES)	ACTUAL NOTCH WIDTH (INCHES)	ACTUAL RELEASE RATE (cfs)
West	13.94	14,295	286	523	6.6	18.0	119.14	2.38	5.5	5.5	2.53
East	2.22	2,277	46	80	6.8	18.0	16.06	0.32	0.75	0.8	0.36



NO.	REVISION	BY	DATE	APPR

Kimley-Horn
 2020 KIMLEY-HORN AND ASSOCIATES, INC.
 4582 South Ulster Street, Suite 1500
 Denver, Colorado 80237 (303) 228-2300

DESIGNED BY: DLS
 DRAWN BY: ECZ
 CHECKED BY: DLS
 DATE: 03/11/20

PARKER & PINE MINOR DEVELOPMENT FILING NO. 1
 PARKER, CO
 CONSTRUCTION DOCUMENTS
 POND DETAILS

PRELIMINARY
 FOR REVIEW ONLY
 NOT FOR CONSTRUCTION
Kimley-Horn
 Kimley-Horn and Associates, Inc.

PROJECT NO.
096502001
 DRAWING NAME
096502001ST_DET
C6.4



K:\DEN_C\1\096502001 - Misc. Files - Parker - BA\CADD\PlanSheet\096502001DRM.dwg 7:40:11 AM 10/11/2019 10:57 AM
 THIS DOCUMENT, TOGETHER WITH ALL CONCEPTS AND DESIGNS PRESENTED HEREIN, IS AN INSTRUMENT OF SERVICE. IT IS INTENDED ONLY FOR THE SPECIFIC PROJECT AND SITE INDICATED HEREON. IT IS NOT TO BE REPRODUCED, COPIED, OR TRANSMITTED IN ANY FORM OR BY ANY MEANS, WITHOUT THE WRITTEN AUTHORIZATION AND ADAPTATION BY KIMLEY-HORN AND ASSOCIATES, INC. SHALL BE WITHOUT LIABILITY TO KIMLEY-HORN AND ASSOCIATES, INC.

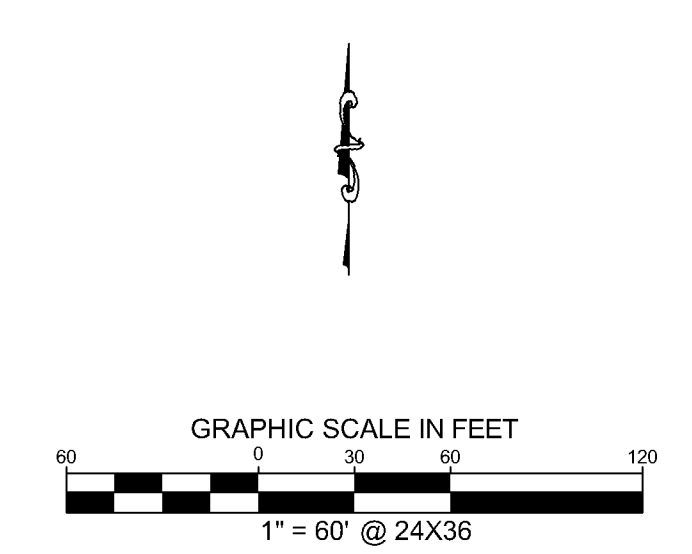
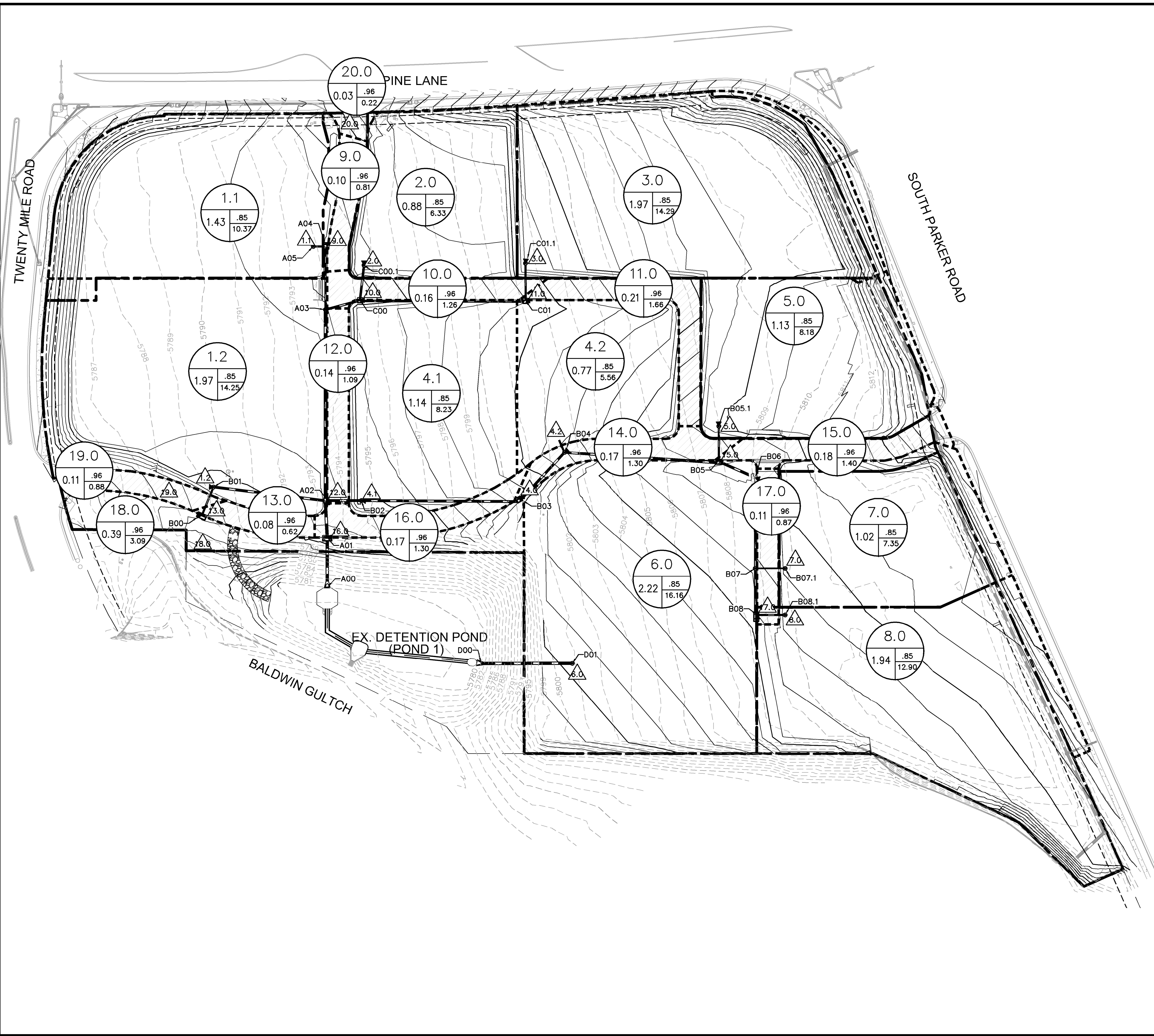

- LEGEND**
- A A = BASIN DESIGNATION
 - B B = AREA (ACRES)
 - C C = BASIN IMPERVIOUSNESS
 - D D = 100YR DESIGN STORM RUNOFF (CFS)
- FLOW DIRECTION
 - DRAINAGE BASIN BOUNDARY
 - EXISTING PROPERTY LINE
 - EXISTING CONTOUR
 - PROPOSED CONTOUR
 - EXISTING STORM SEWER
 - PROPOSED STORM SEWER
 - PROPOSED STORM INLET

NO. REVISION BY DATE

APP

2019 KIMLEY-HORN AND ASSOCIATES, INC.
 4552 South Ulster Street, Suite 1500
 Denver, Colorado 80237 (303) 228-2300

DESIGNED BY: DLS
 DRAWN BY: ECZ
 CHECKED BY: DLS
 DATE: 11/11/19

PARKER & PINE
 PARKER, CO
 CONSTRUCTION DOCUMENTS
PRELIMINARY DRAINAGE AREA MAP

PRELIMINARY
 FOR REVIEW ONLY
 NOT FOR
 CONSTRUCTION

PROJECT NO.
096502001

DRAWING NAME
096502001DRM

DRAINAGE

