

# SVMD SANITARY AND WATER CONSTRUCTION PLANS FOR: COMPARK VILLAGE SOUTH TRACT A, FILING NO. 1 AMENDMENT 1

COMPARK VILLAGE SOUTH,  
TOWN OF PARKER, COUNTY OF DOUGLAS, STATE OF COLORADO

## TRACT A, COMPARK VILLAGE SOUTH FILING NO. 1, AMENDMENT 1, LOCATED IN THE SOUTH HALF OF SECTION 6, TOWNSHIP 6 SOUTH, RANGE 66 WEST OF THE SIXTH PRINCIPAL MERIDIAN, TOWN OF PARKER, COUNTY OF DOUGLAS, STATE OF COLORADO STONEGATE VILLAGE METRO DISTRICT WATER AND SANITARY SEWER PLAN

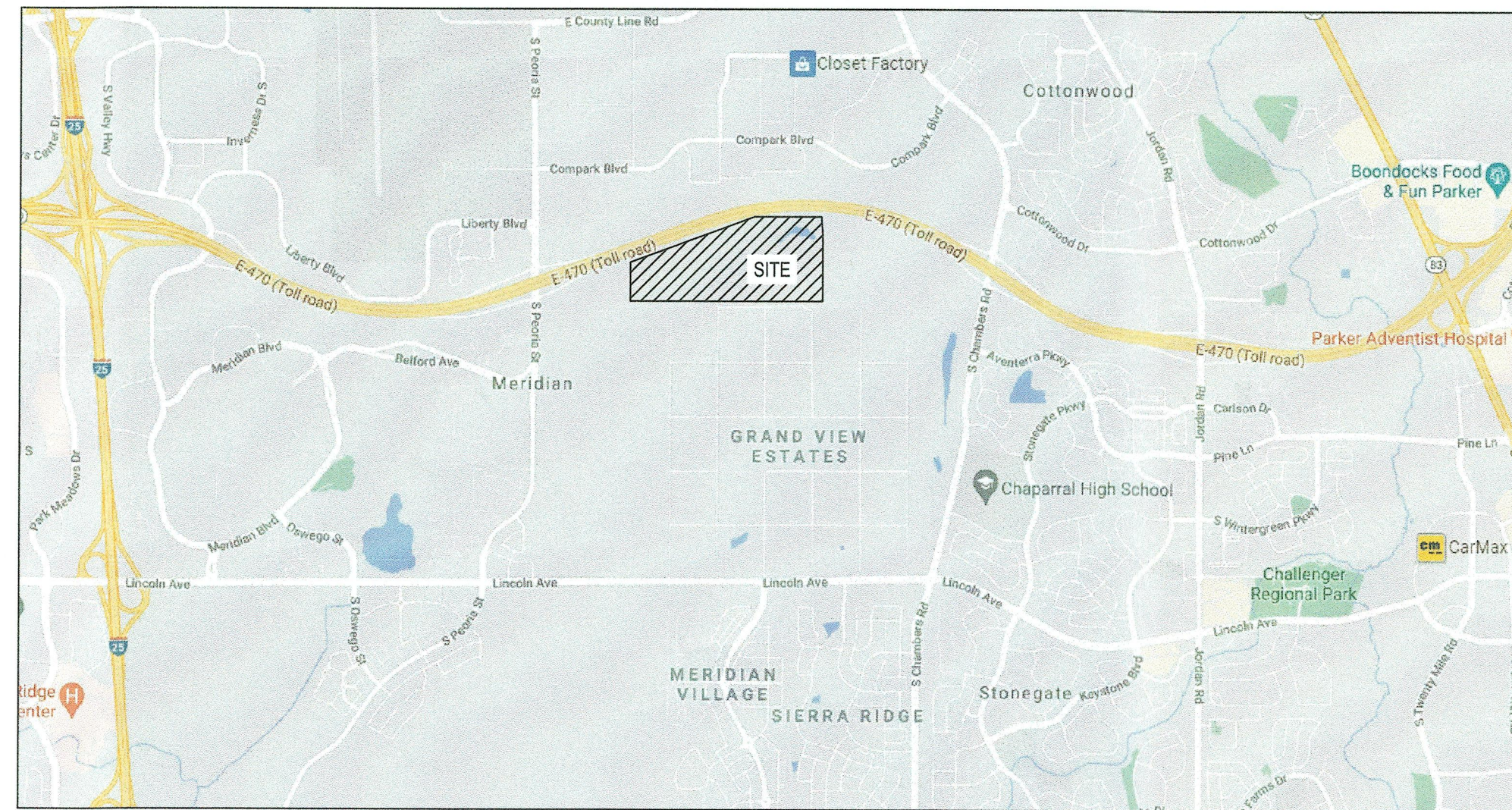

Vicinity Map

N.T.S.

LEGEND	
PROPOSED	EXISTING
CATV	CATV
E	EX E
OHE	EX OE
OHE/C	EX OHE/C
UE	EX UE
FO	EX FO
F	EX F
G	EX G
IRR	EX IRR
SS	EX SS
T	EX T
OT	EX OT
W	EX W
UD	EX UD
X	EX X
>	EX >
---	EX ---
- - -	EX - - -
- - -	EX - - -
- - -	EX - - -
- - -	EX - - -
[ ]	EX [ ]
[ ]	EX [ ]
[ ]	EX [ ]
[ ]	EX [ ]
4990	EX 4990
[ ]	EX [ ]
[ ]	EX [ ]

CABLE TV LINE W/ PEDESTAL

ELECTRIC LINE W/ BOX, METER, AND LIGHT

OVERHEAD ELECTRIC WITH POLE

OVERHEAD ELECTRIC COMMUNICATIONS

UNDERGROUND ELECTRIC

FIBER OPTIC LINE W/ TRAFFIC CONTROL BOX

FIRE

GAS LINE W/ DRY UTILITY VAULT

IRRIGATION

SANITARY SEWER W/ MANHOLE

STORM SEWER FES W/ MAHNOLE, RIPRAP

TELEPHONE LINE W/ PEDESTAL

OVERHEAD TELEPHONE

WATER LINE, VALVE, FITTINGS, METER, AND HYDRANT

UNDERDRAIN

CURB AND GUTTER

WHEEL STOP

CONTOURS

TRASH ENCLOSURE

UNDERDRAIN W/ TYPE R INLET

FENCE LINE

DRAINAGE SWALE

RIGHT-OF-WAY

SECTION LINE

PROPERTY LINE

LOT LINE

EASEMENT

IRRIGATION CONTROL VALVE BOX

PEDESTRIAN LIGHT

STREET LIGHT

TRAFFIC LIGHT

SPOT ELEVATION

FLOW OF WATER

SIGN

### ABBREVIATION LEGEND

TW	GRADE AT TOP OF WALL
BG	GRADE AT BOTTOM OF WALL
PC	POINT OF CURVE
PT	POINT OF TANGENT
Δ	DELTA, HORIZONTAL CURVE DIRECTION CHANGE
CL	CENTERLINE
FL	FLOWLINE
DL	DOUBLE
C.O.	CLEAN OUT
K	RATE OF CURVATURE
AD	ABSOLUTE GRADE DIFFERENCE IN %
VC	VERTICAL CURVE
PVT	POINT OF VERTICAL TANGENT
PVI	POINT OF VERTICAL INTERSECTION
PI	POINT OF TANGENT INTERSECTION
ROW	RIGHT OF WAY
PVMT	PAVEMENT
HP	HIGH POINT
LP	LOW POINT
PCR	POINT OF CURB RETURN
PCC	POINT OF COMPOUND CURVE
PRC	POINT OF REVERSE CURVE
EX, EX.	EXISTING
PR, PR.	PROPOSED
ME	MATCH EXISTING
TC	BACK TOP OF CURB
FG	FINISHED GRADE
STA	STATION
EL, ELEV	ELEVATION
FF	FINISHED FLOOR
TC	TOP OF CONCRETE
BP	BOTTOM OF PIPE
T/P	TOP OF PIPE
Ø	DIAMETER
UE	UTILITY EASEMENT
ESMT	EASEMENT
HCL	HORIZONTAL CONTROL LINE
N	NORTH/NORTHING
E	EAST/EASTING
W	WEST
S	SOUTH
R	RADIUS
LC	LENGTH OF CORD
L	LENGTH
CB	CHORD BEARING

**DEVELOPER/ OWNER**  
CENTURY COMMUNITIES  
8390 E. CRESCENT PARKWAY,  
SUITE 650, GREENWOOD VILLAGE,  
CO 80111  
PHONE: 303-770-8300  
CONTACT: CINDY MYERS

**SURVEYOR**  
MERRICK & COMPANY  
5970 GREENWOOD PLAZA BLVD.  
GREENWOOD VILLAGE, CO 80111  
PHONE: 303-751-0741  
CONTACT: KENNETH G. OUELLETTE, PLS

**PLANNER**  
PCS GROUP  
200 KLAMATH ST, DENVER, CO  
80223  
PHONE: 720-259-8248  
CONTACT: PAUL SHOUKAS

**ENGINEER**  
MERRICK & COMPANY  
5970 GREENWOOD PLAZA BLVD.  
GREENWOOD VILLAGE, CO 80111  
PHONE: 303-751-0741  
CONTACT: KRISTOFER K. WIEST, PE

### TOWN & UTILITY CONTACTS

TOWN OF PARKER  
CONTACT: MIKE WAUGH  
PHONE: 303-840-9546

INTERMOUNTAIN REA  
CONTACT: BROOKS KAUFMAN  
PHONE: 303-688-3100

CENTURY LINK  
CONTACT: WILLIAM BENSON  
PHONE: 303-320-8333

SOUTH METRO FIRE DISTRICT  
CONTACT: MICHELLE HERJAN  
PHONE: 720-488-7200

COMCAST  
CONTACT: KEVIN YOUNG  
PHONE: 720-490-3867

XCEL ENERGY  
CONTACT: MICHELLE O'NAN  
PHONE: 303-329-1618

STONEGATE VILLAGE METRO DISTRICT  
CONTACT: SCOTT BARNETT  
PHONE: 303-649-9857

### DISTRICT APPROVALS

THESE DESIGN PLANS AND CONTRACT DOCUMENTS ARE REVIEWED FOR CONCEPT AND GENERAL CONFORMANCE TO THE DISTRICT'S MINIMUM STANDARDS ONLY, AND THE PRIMARY RESPONSIBILITY FOR THE DESIGN ADEQUACY IS TO REMAIN WITH THE ENGINEER OF RECORD. THIS REVIEW DOES NOT IMPLY RESPONSIBILITY BY EITHER THE STONEGATE VILLAGE METROPOLITAN DISTRICT OR THE DISTRICT ENGINEER FOR COMPLETENESS, ACCURACY OR CORRECTNESS OF CALCULATIONS. THE REVIEW DOES NOT IMPLY THAT QUANTITIES OF ITEMS INDICATED ON THE PLANS ARE THE FINAL QUANTITIES REQUIRED. THE REVIEW SHALL NOT BE CONSTRUED FOR ANY REASON AS ACCEPTANCE OF FINANCIAL RESPONSIBILITY BY THE STONEGATE VILLAGE METROPOLITAN DISTRICT FOR ADDITIONAL ITEMS AND ADDITIONAL QUANTITIES OF ITEMS SHOWN THAT MAY BE REQUIRED DURING THE CONSTRUCTION PHASE.

APPROVED FOR CONSTRUCTION WITHIN ONE YEAR OF THIS DATE:

BY: *Scott Barnett*  
STONEGATE VILLAGE METROPOLITAN DISTRICT ENGINEER

DATE: 7/19/2024



THIS WORK WAS DONE BY ME, OR UNDER MY SUPERVISION

ALL FIRE HYDRANTS SHALL BE INSTALLED ACCORDING TO WATER UTILITY STANDARDS. THE NUMBER AND LOCATIONS OF THE FIRE HYDRANTS AS SHOWN ON THE OVERALL UTILITY PLAN ARE CORRECT AS SPECIFIED BY THE TOWN OF PARKER COMMUNITY DEVELOPMENT DEPARTMENT

*Paul Shoukas*

07/23/2024

FIRE CODE OFFICIAL OR DESIGNATED REPRESENTATIVE

DATE

(NOTE - UNDERGROUND FIRE LINE (UFL) SUBMITTAL DOCUMENTS MUST MEET THE REQUIREMENTS OF NFPA 24 WHEN SUBMITTING FOR REVIEW.)

Sheet List Table		
01	COVER SHEET	C7.1
02	GENERAL NOTES	C7.2
03	OVERALL UTILITY PLAN	C7.3
04	WATER-P&P	C7.4
05	SAN-P&P	C7.5
06	STANDARD DETAILS - WATER	C7.6
07	STANDARD DETAILS - WATER	C7.7
08	STANDARD DETAILS - WATER	C7.8
09	STANDARD DETAILS - WATER	C7.9
10	STANDARD DETAILS - WATER	C7.10
11	STANDARD DETAILS - SANITARY	C7.11
12	STANDARD DETAILS - SANITARY	C7.12

WATER MAIN QUANTITIES		
DESCRIPTION	AMOUNT	UNIT
8" PVC WATER MAIN	683.96	LF
8" TO 6" TEE/W/ KICK BLOCK	33	EACH
8" 11.25 DEGREE BEND	1	EACH
8" 22.5 DEGREE BEND	1	EACH
VERTICAL BEND	2	EACH
FIRE HYDRANT ASSEMBLY	1	EACH
REMOVE EXISTING 8" PLUG AND MAKE DRY CONNECT	2	EACH
SANITARY SEWER MAIN QUANTITIES		
DESCRIPTION	AMOUNT	UNIT
8" SANITARY SEWER MAIN (0-36" DEPTH)	603.6	LF
4" DIAMETER MANHOLES (0-20' DEPTH)	2	EACH
CONNECTION TO EXISTING SANITARY SEWER	1	EACH

### FIRE/LIFE SAFETY REVIEW BLOCK

All fire hydrants shall be installed according to water utility standards. The number and locations of the fire hydrants as shown on the Overall Utility Plan are correct as specified by the Town of Parker, Community Development Department.

*Paul Shoukas*

07/23/2024

Fire Code Official or Designated Representative

(NOTE - Underground Fire Line (UFL) submittal documents must meet the requirements of NFPA 24 when submitting for review.)

The Town of Parker review constitutes general compliance with the Town's Standards and approved variances, subject to these plans being stamped, signed, and dated by the professional engineer of record. Review by the Town does not constitute approval of the plan design or accuracy and correctness of engineering calculations. Errors in the design or calculations remain the responsibility of the registered professional engineer whose stamp and signature are affixed to this document.

This review does not constitute approval of any private on-site improvements which may be shown. Construction cannot commence until all required drainage/traffic report(s), final development plan(s), special review(s), grading permit, and/or other permits are complete, approved and on file with the Town of Parker.

Town of Parker, Director of Engineering/Public Works

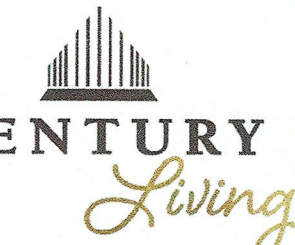
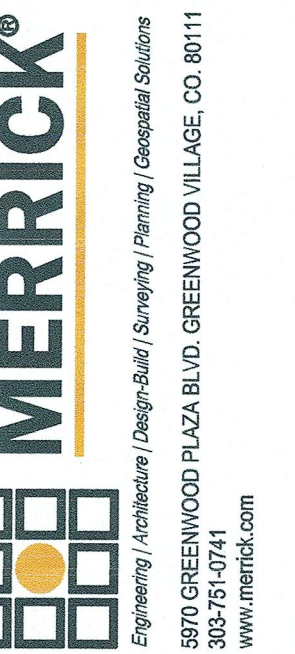

REV/REVISION DESCRIPTION	DATE	ISSUED FOR CONSTRUCTION
0	7/19/2024	ISSUED FOR CONSTRUCTION

## COMPARK VILLAGE SOUTH WATER AND SANITARY PLANS COVER SHEET



JOB NUMBER	120950
DATE	07/11/2024
SHEET	C7.1
	01







THE TOWN OF PARKER ENGINEERING DEPARTMENT IS AN INSTRUMENT OF SERVICE PROVIDED BY MERRICK & COMPANY, INC. A SERVICE PROVIDER TO THE TOWN OF PARKER. THIS PLAN IS THE PROPERTY OF MERRICK & COMPANY, INC. AND IS NOT TO BE REPRODUCED, COPIED, OR TRANSMITTED IN ANY FORM OR BY ANY MEANS, ELECTRONIC OR MECHANICAL, WITHOUT THE WRITTEN CONSENT OF MERRICK & COMPANY, INC. ANY REUSE OR MODIFICATION OF ANY INFORMATION NOT A PART OF THIS INSTRUMENT WITHOUT THE WRITTEN CONSENT OF MERRICK & COMPANY, INC. SHALL BE AT THE USER'S RISK AND WITHOUT LIABILITY TO MERRICK & COMPANY, INC.

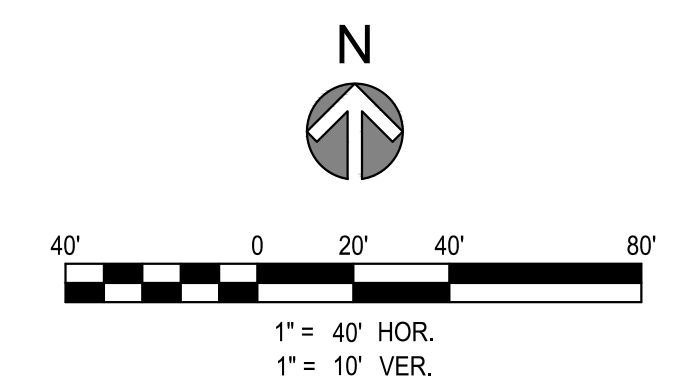
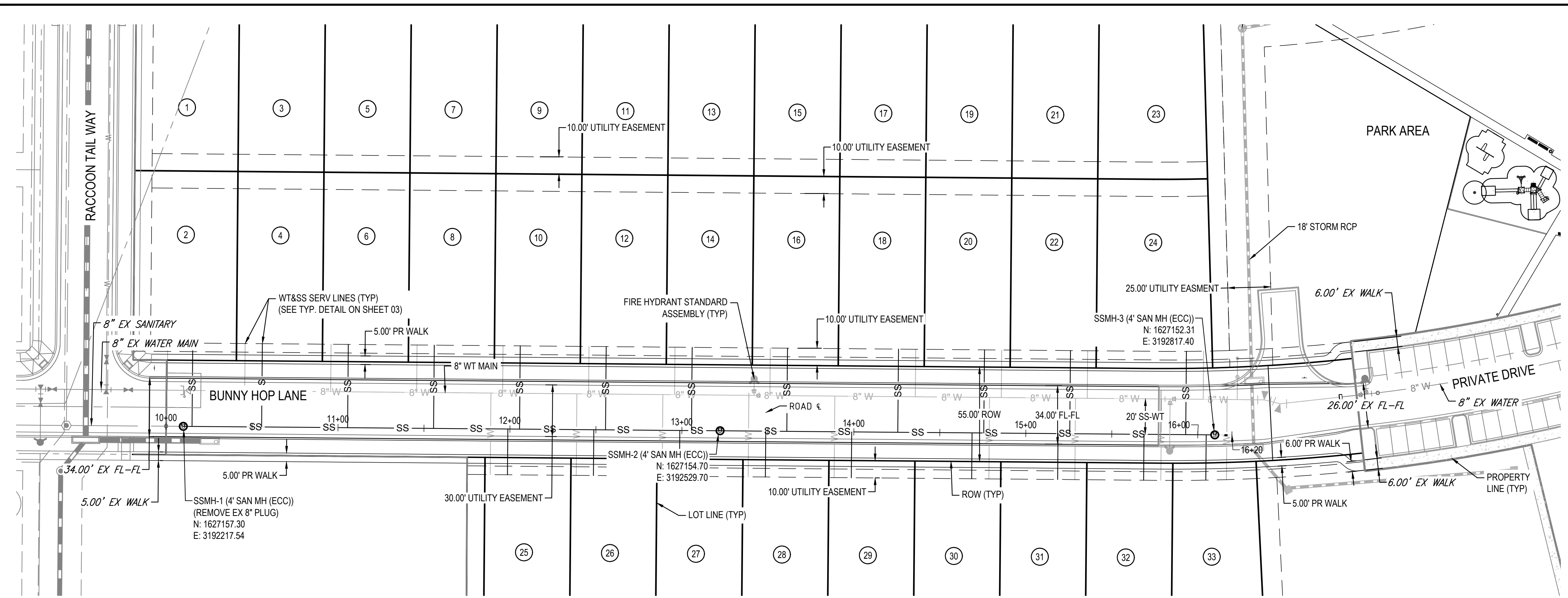

- NOTES:**
1. ALL STATIONING & PIPE LENGTHS ARE TO CENTER OF STRUCTURE.
  2. ALL SANITARY SEWER PVC TO BE SDR 35 PVC UNLESS SPECIFIED OTHERWISE.
  3. CONTRACTOR TO VERIFY LOCATION/ELEVATION OF ALL UTILITIES PRIOR TO CONSTRUCTION.
  4. ALL MANHOLES TO HAVE 48" INNER DIAMETER.

BUNNY HOP LANE SANITARY PROFILE

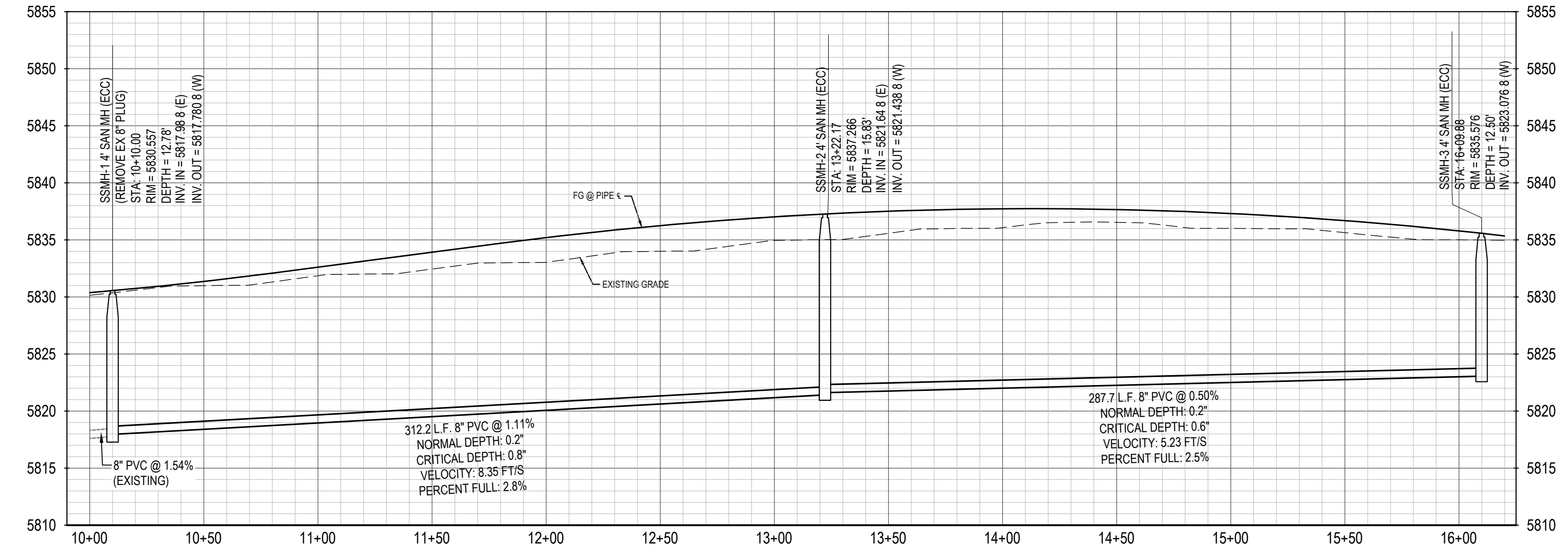

SANITARY SEWER SERVICE TABLE					
PLOT NUMBER	LENGTH (FT)	SLOPE	INV @ MAN	FG @ MAN	INV @ STUB
1	26.47	2.00%	5806.36	5822.18	5806.00
2	58.45	2.00%	5819.03	5830.65	5820.10
3	26.47	2.00%	5806.51	5822.81	5806.15
4	48.31	2.00%	5818.44	5831.44	5820.43
5	26.47	2.00%	5806.96	5823.82	5808.47
6	48.31	2.00%	5819.04	5832.75	5820.99
7	26.47	2.00%	5807.21	5824.61	5808.72
8	48.31	2.00%	5819.59	5834.06	5821.54
9	26.47	2.00%	5807.46	5825.49	5809.97
10	48.31	2.00%	5820.15	5835.33	5822.10
11	26.47	2.00%	5807.91	5826.29	5809.41
12	48.31	2.00%	5820.70	5836.34	5822.65
13	26.47	2.00%	5808.16	5827.25	5809.67
14	48.31	2.00%	5821.25	5837.09	5823.20
15	26.47	2.00%	5808.41	5827.95	5809.92
16	48.31	2.00%	5821.83	5837.58	5823.78
17	26.47	2.00%	5808.66	5827.85	5810.17
18	48.35	2.00%	5822.16	5837.72	5824.11
19	26.47	2.00%	5809.21	5827.85	5810.72
20	48.34	2.00%	5822.40	5837.51	5824.35
21	26.47	2.00%	5809.46	5827.25	5810.97
22	48.32	2.00%	5822.55	5837.02	5824.60
23	27.87	2.00%	5809.78	5836.62	5811.29
24	48.49	2.00%	5822.99	5835.93	5824.94
25	26.60	2.00%	5820.07	5835.17	5821.58
26	26.60	2.00%	5820.63	5836.22	5822.14
27	26.60	2.00%	5821.18	5837.00	5822.69
28	26.60	2.00%	5821.77	5837.50	5823.28
29	26.60	2.00%	5822.02	5837.72	5823.53
30	26.67	2.00%	5822.37	5837.56	5823.88
31	26.68	2.00%	5822.62	5837.10	5824.13
32	26.69	2.00%	5822.87	5836.38	5824.38
33	26.31	2.00%	5823.05	5835.68	5824.56



REV	REVISION DESCRIPTION	DATE	CHKD	APPR
0	ISSUED FOR CONSTRUCTION	7/19/2024		

**COMPARK VILLAGE SOUTH**  
WATER AND SANITARY  
PLANS  
SAN-P&P

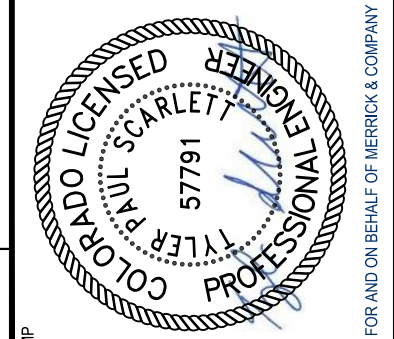

The Town of Parker review constitutes general compliance with the Town's Standards and approved variances, subject to these plans being stamped, signed, and dated by the professional engineer of record. Review by the Town does not constitute approval of the plan design or accuracy and correctness of engineering calculations. Errors in the design or calculations remain the responsibility of the registered professional engineer whose stamp and signature are affixed to this document.

This review does not constitute approval of any private on-site improvements which may be shown. Construction cannot commence until all required drainage/traffic report(s), final development plan(s), special review(s), grading permit, and/or other permits are complete, approved and on file with the Town of Parker.

Town of Parker, Director of Engineering/Public Works



JOB NUMBER	120950
DATE	07/11/2024
SHEET	C7.5
	05

THE NEW ORLEANS SUBURBAN METRO DEVELOPMENT IS AN INSTRUMENT OF SERVICE PROVIDED BY MERRICK AND COMPANY, INC. A REGISTERED PROFESSIONAL ENGINEER HAS REVIEWED THIS INSTRUMENT OF SERVICE AND HAS DETERMINED THAT IT IS IN ACCORDANCE WITH THE REQUIREMENTS OF THE PROFESSIONAL ENGINEERING ACT AND THE RULES OF THE BOARD OF ENGINEERING AND SURVEYING. IT IS NOT INTENDED OR REPRESENTED TO BE SUITABLE FOR USE IN ANY OTHER JURISDICTION WITHOUT THE PRIOR WRITTEN CONSENT OF MERRICK AND COMPANY. NO LIABILITY SHALL BE ASSUMED FOR THE USE OF THIS INSTRUMENT OF SERVICE IN ANY OTHER JURISDICTION.

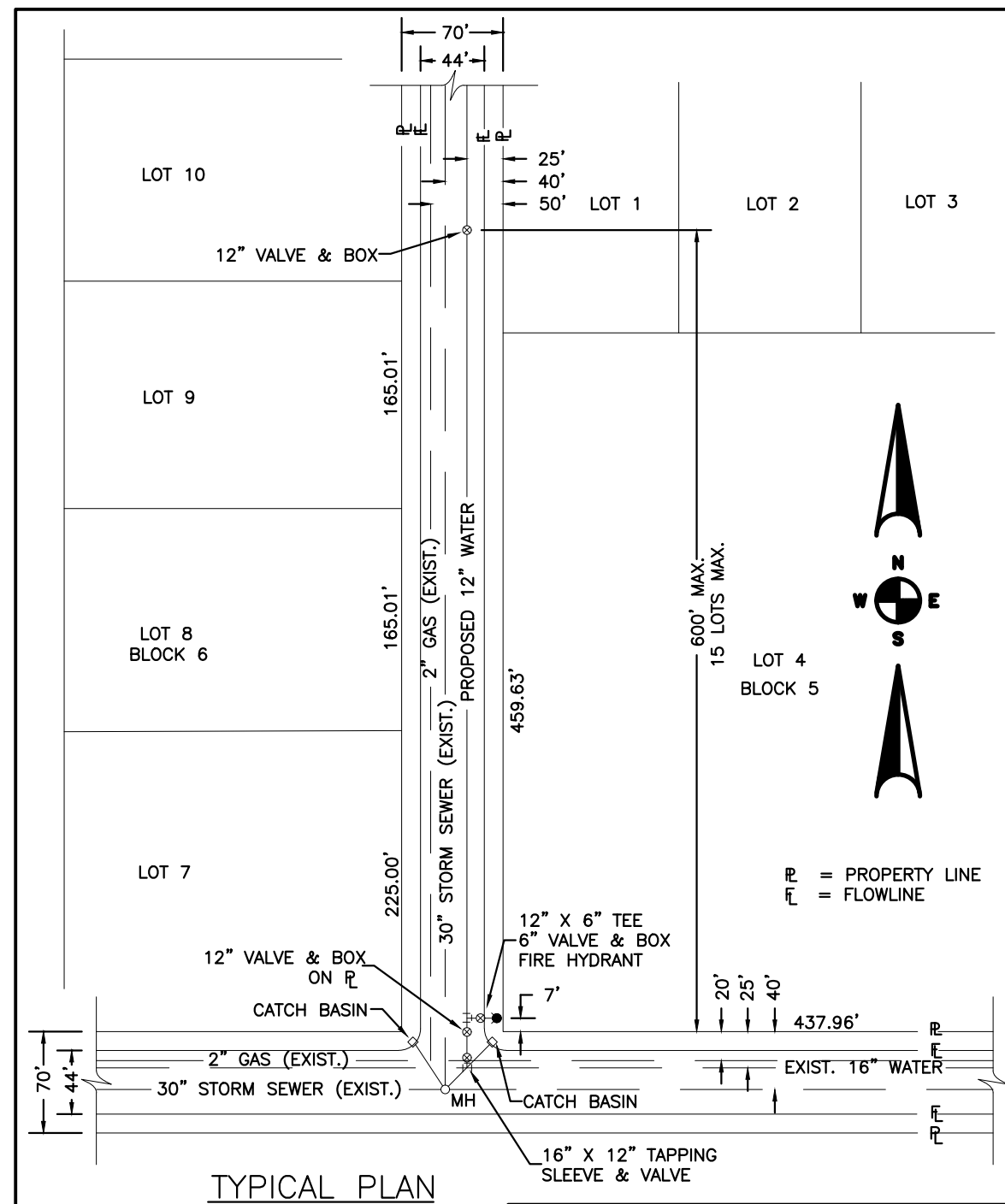

**TYPICAL PLAN**

NOTES:  
 1. SEE "TYPICAL STREET CROSS SECTION - TYPICAL STREET Q<sub>1</sub> PROFILE" DRAWING.  
 2. ALL FIRE HYDRANTS TO BE LOCATED AT POINTS OTHER THAN CORNER INTERSECTIONS SHALL BE INSTALLED AT A LOT LINE EXTENDED.

STONEGATE VILLAGE METROPOLITAN DISTRICT  
 WATER DISTRIBUTION SYSTEM  
 TYPICAL PLAN

SCALE: NONE DATE: 4/00  
 APPROVED: R/JG DISTRICT ENGINEER

2000 REVISION SHEET 1

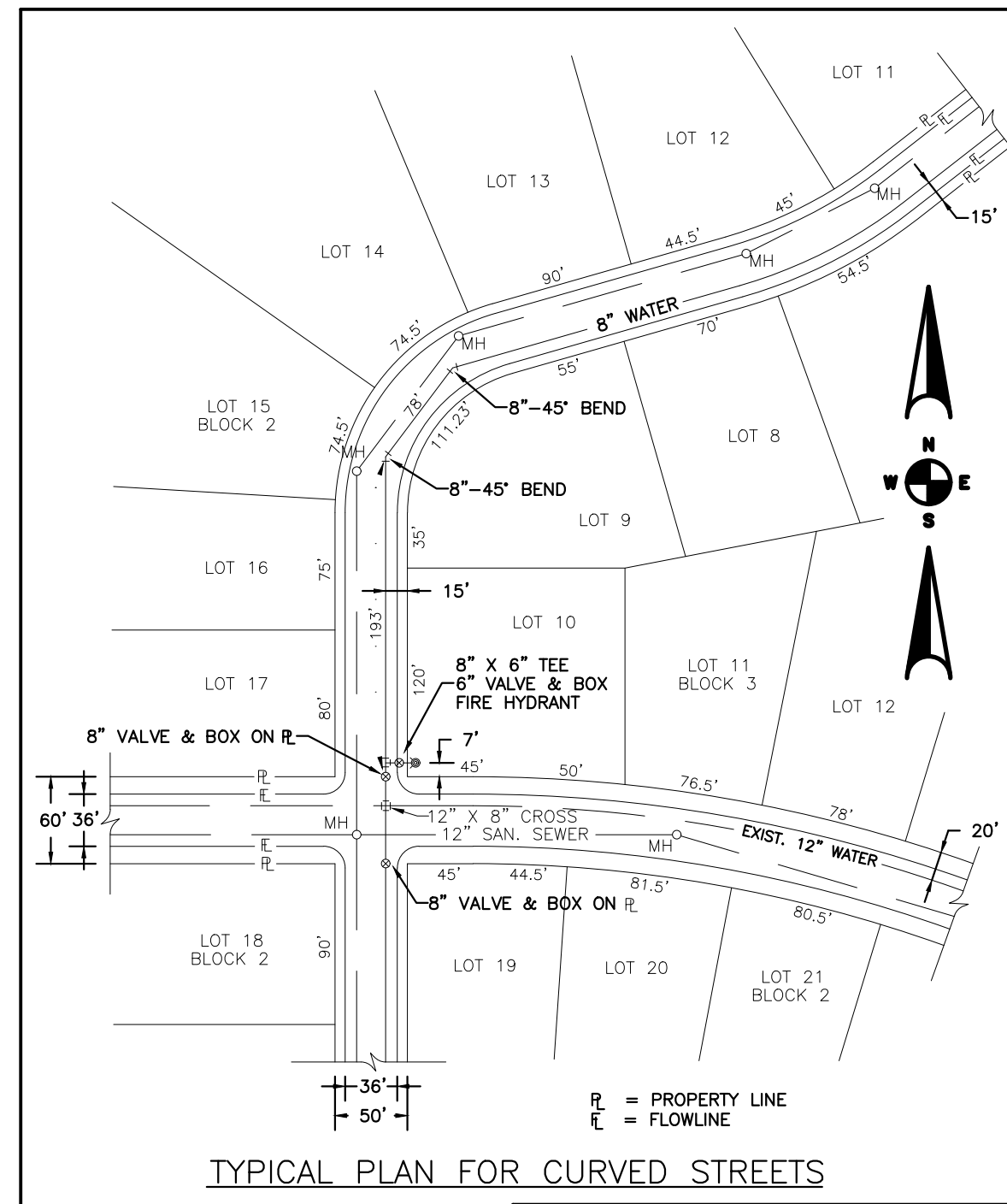

**TYPICAL PLAN FOR CURVED STREETS**

STONEGATE VILLAGE METROPOLITAN DISTRICT  
 WATER DISTRIBUTION SYSTEM  
 TYPICAL PLAN FOR CURVED STREETS

SCALE: NONE DATE: 4/00  
 APPROVED: R/JG DISTRICT ENGINEER

2000 REVISION SHEET 3

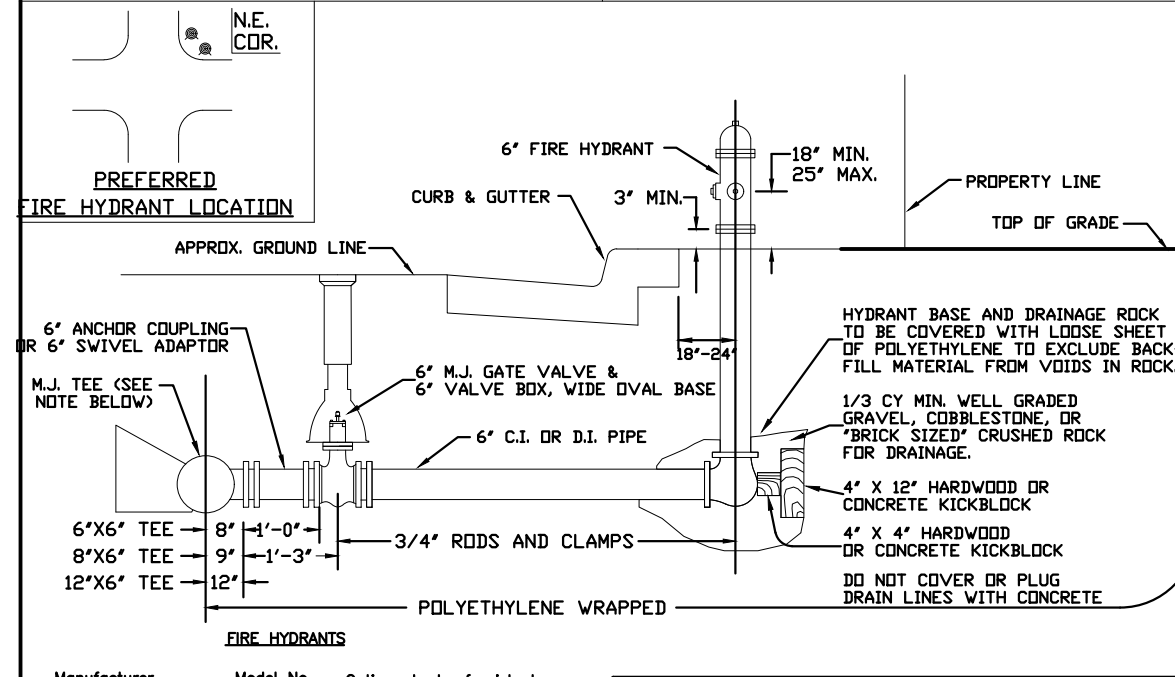
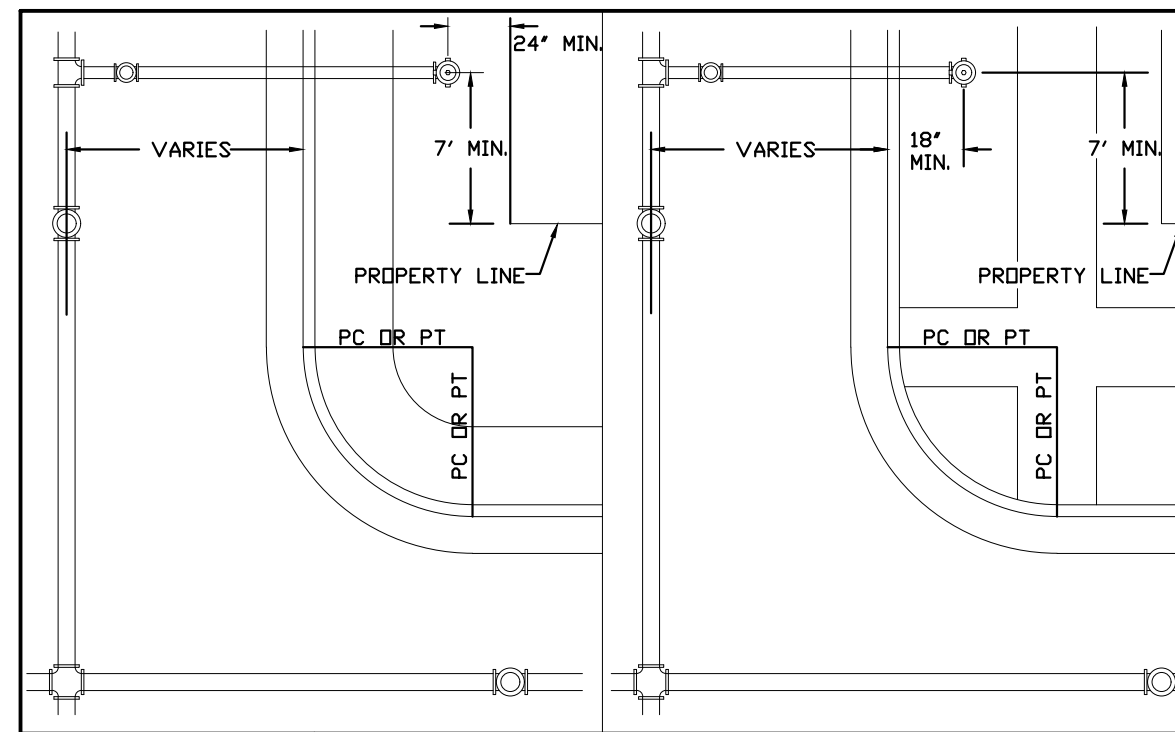

**FIRE HYDRANTS LOCATION & INSTALLATION**

STONEGATE VILLAGE METROPOLITAN DISTRICT

SCALE: NONE DATE: 4/00  
 APPROVED: R/JG DISTRICT ENGINEER

2000 REVISION SHEET 5

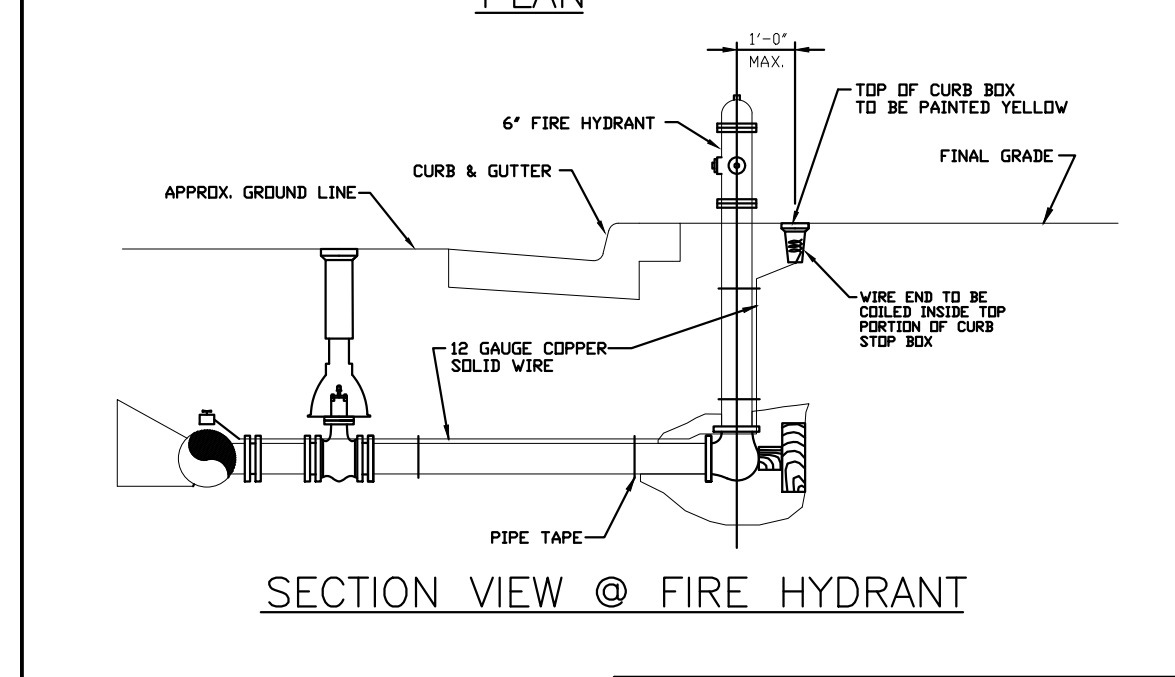
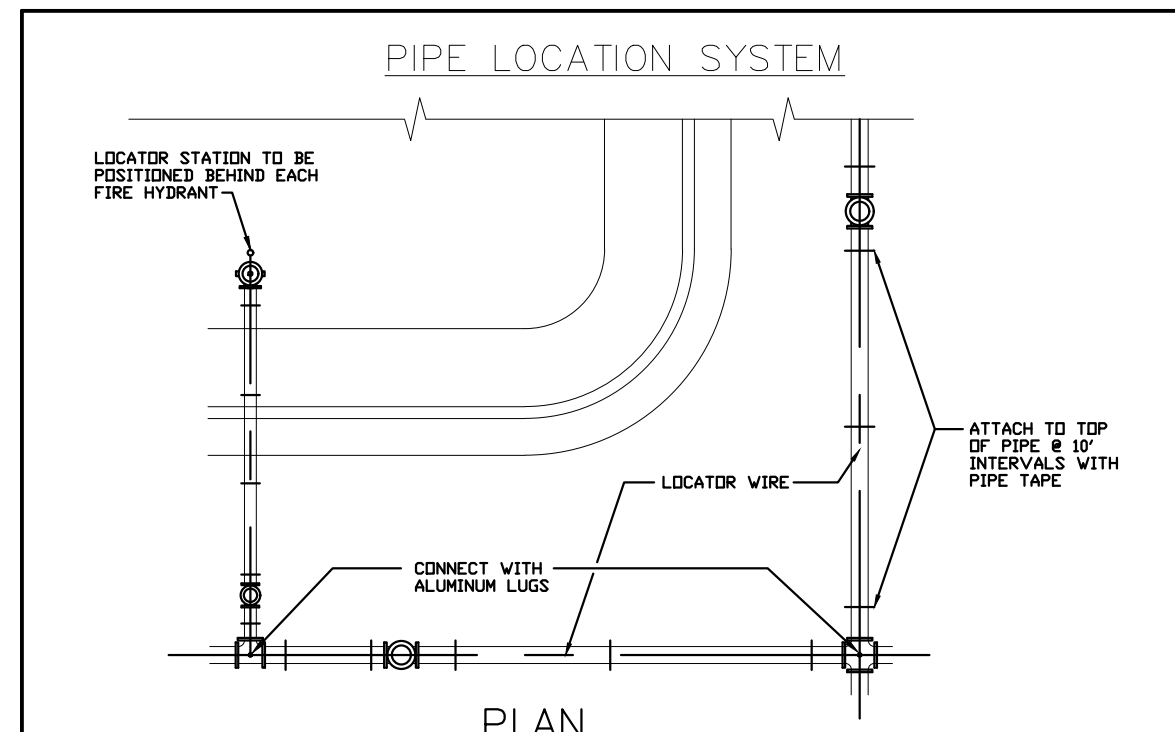

**LOCATOR WIRE DETAILS**

STONEGATE VILLAGE METROPOLITAN DISTRICT

SCALE: NONE DATE: 4/00  
 APPROVED: R/JG DISTRICT ENGINEER

2000 REVISION SHEET 6

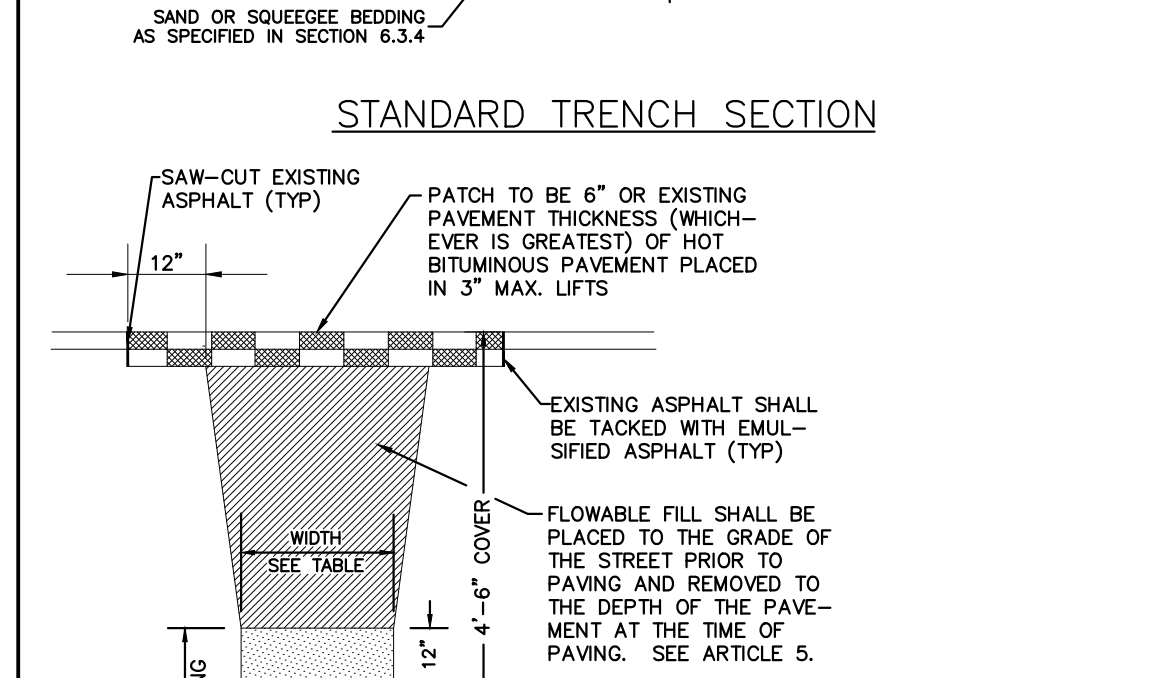
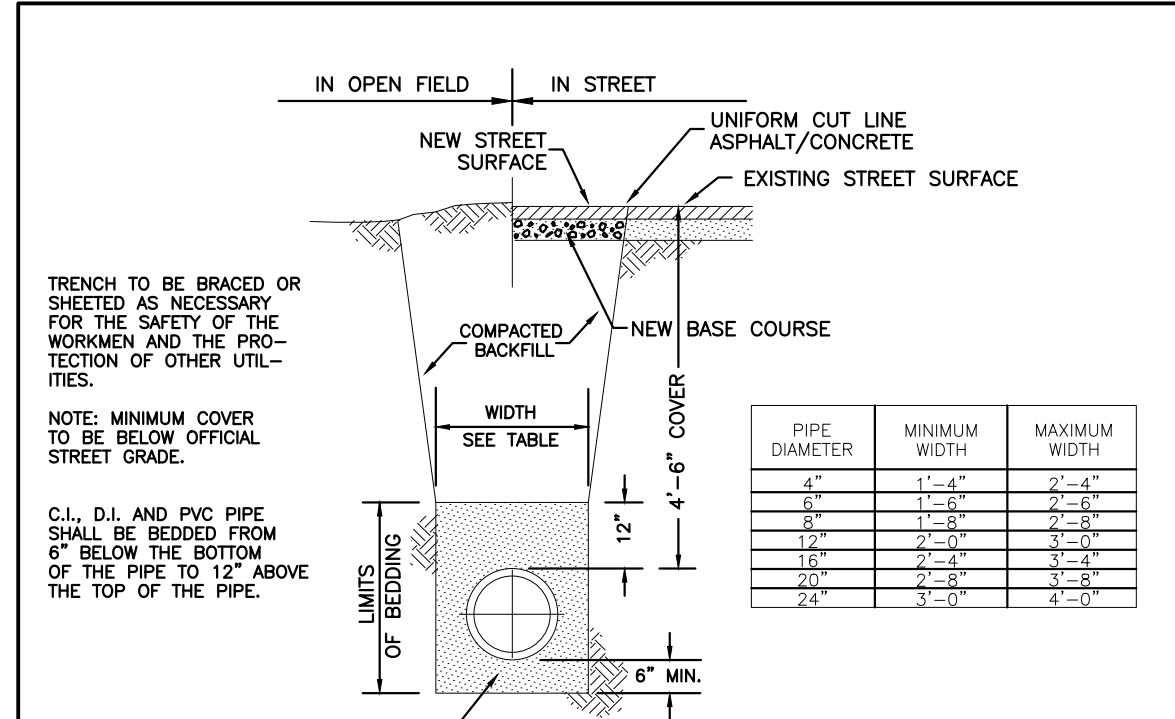

**TYPICAL TRENCH SECTION PIPE PROTECTION**

STONEGATE VILLAGE METROPOLITAN DISTRICT

SCALE: NONE DATE: 4/00  
 APPROVED: R/JG DISTRICT ENGINEER

2000 REVISION SHEET 8

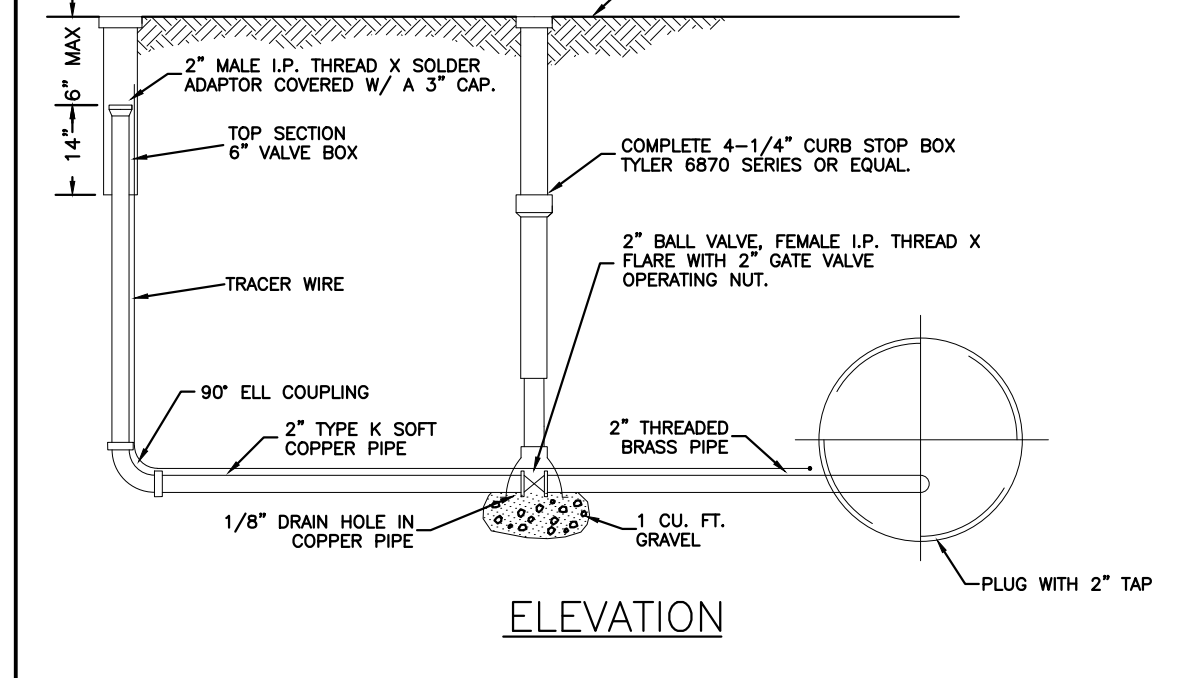
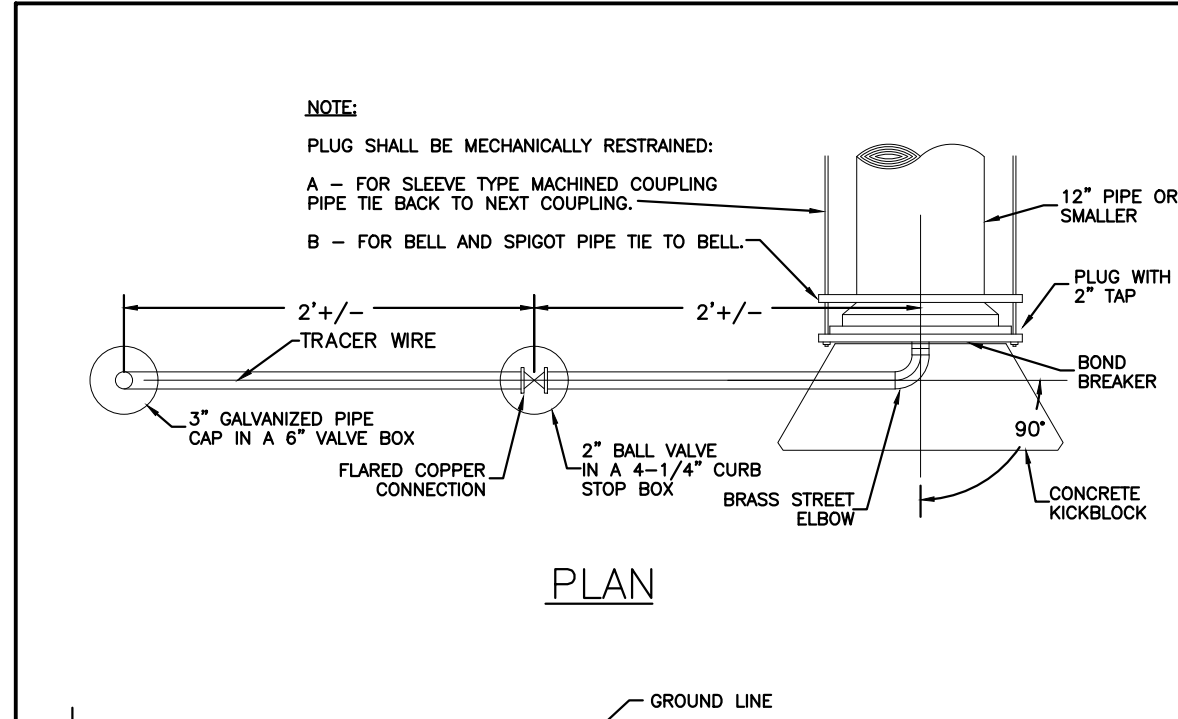

**BLOW-OFF INSTALLATION FOR 12" & SMALLER PIPE**

STONEGATE VILLAGE METROPOLITAN DISTRICT

SCALE: NONE DATE: 4/00  
 APPROVED: R/JG DISTRICT ENGINEER

2000 REVISION SHEET 9

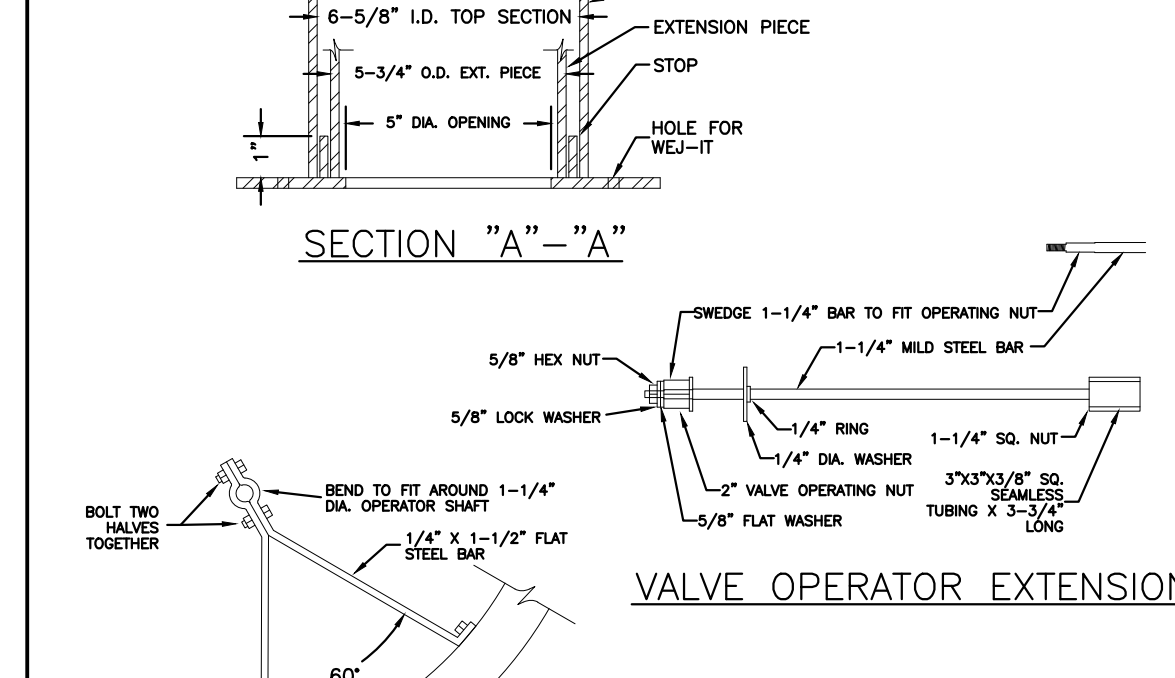
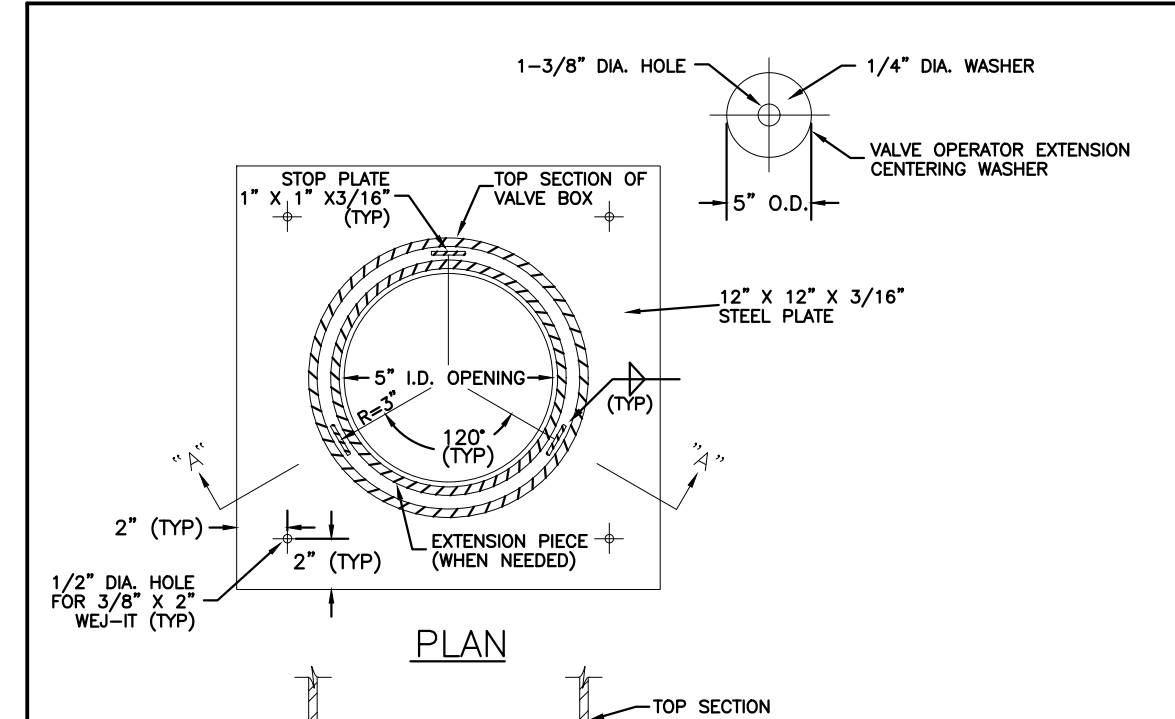

**VALVE BOX SUPPORT PLATE AND EXTENSION GUIDE**

STONEGATE VILLAGE METROPOLITAN DISTRICT

SCALE: NONE DATE: 4/00  
 APPROVED: R/JG DISTRICT ENGINEER

2000 REVISION SHEET 12

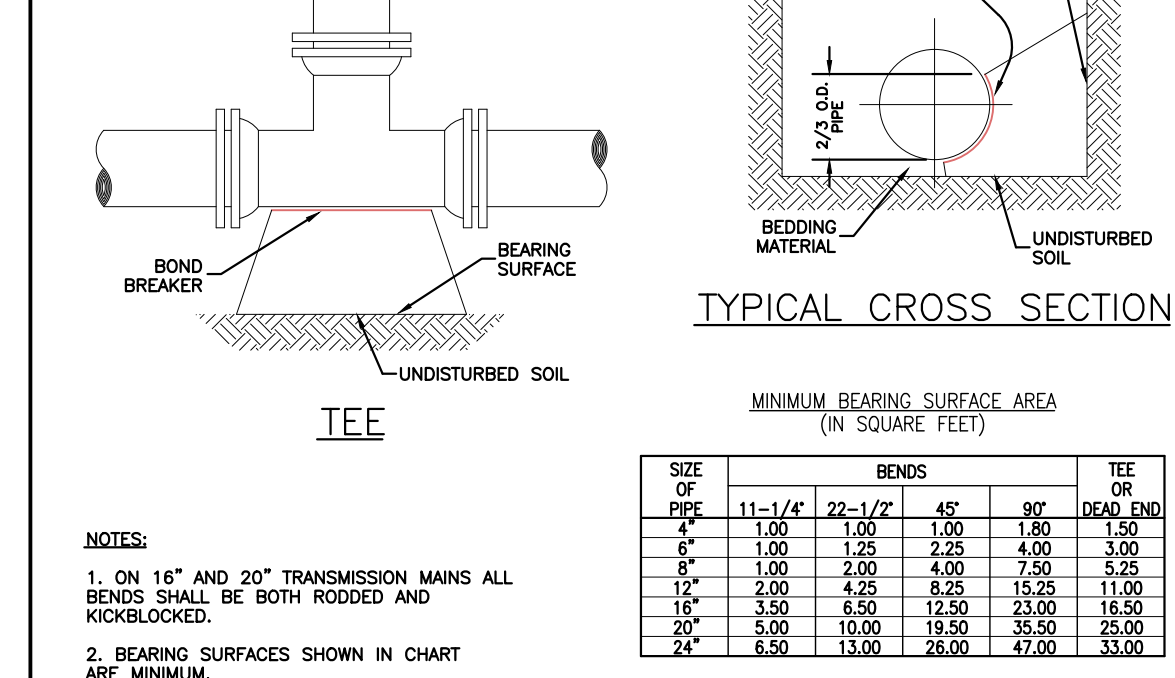
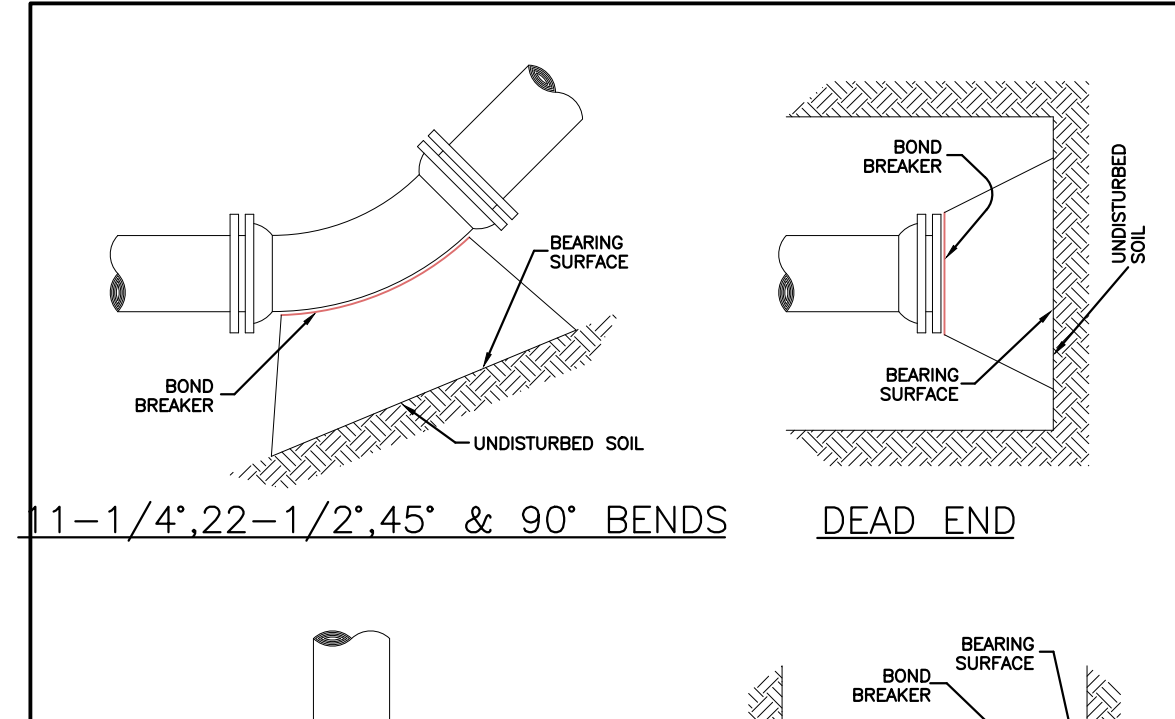

**CONCRETE KICKBLOCKS BEARING SURFACES AND INSTALLATION**

STONEGATE VILLAGE METROPOLITAN DISTRICT

SCALE: NONE DATE: 4/00  
 APPROVED: R/JG DISTRICT ENGINEER

2000 REVISION SHEET 17

NO.	ISSUED FOR CONSTRUCTION	DATE	CHNO/CHKD/APPR
0	ISSUED FOR CONSTRUCTION	7/19/2024	



THE USE OF THESE STANDARD DETAILS IS AN ACKNOWLEDGMENT OF THE DESIGN RESPONSIBILITY OF THE ENGINEER. THE ENGINEER SHALL BE RESPONSIBLE FOR THE DESIGN OF THE PROJECT AND FOR THE SELECTION OF THE APPROPRIATE STANDARD DETAIL. THE ENGINEER SHALL BE RESPONSIBLE FOR THE SELECTION OF THE APPROPRIATE STANDARD DETAIL. THE ENGINEER SHALL BE RESPONSIBLE FOR THE SELECTION OF THE APPROPRIATE STANDARD DETAIL.

### LENGTH OF TIED PIPE

PIPE SIZE	4"		6"		8"		12"		16"		20"		24"	
	D	L	D	L	D	L	D	L	D	L	D	L	D	L
3/4"	6.0	M.S.	3/4"	13.0	M.S.	3/4"	20.0	M.S.	3/4"	30.0	M.S.	3/4"	40.0	M.S.
1"	6.0	M.S.	1"	13.0	M.S.	1"	20.0	M.S.	1"	30.0	M.S.	1"	40.0	M.S.
1 1/4"	6.0	M.S.	1 1/4"	13.0	M.S.	1 1/4"	20.0	M.S.	1 1/4"	30.0	M.S.	1 1/4"	40.0	M.S.
2"	6.0	M.S.	2"	13.0	M.S.	2"	20.0	M.S.	2"	30.0	M.S.	2"	40.0	M.S.
2 1/2"	6.0	M.S.	2 1/2"	13.0	M.S.	2 1/2"	20.0	M.S.	2 1/2"	30.0	M.S.	2 1/2"	40.0	M.S.
3"	6.0	M.S.	3"	13.0	M.S.	3"	20.0	M.S.	3"	30.0	M.S.	3"	40.0	M.S.
4"	6.0	M.S.	4"	13.0	M.S.	4"	20.0	M.S.	4"	30.0	M.S.	4"	40.0	M.S.
4 1/2"	6.0	M.S.	4 1/2"	13.0	M.S.	4 1/2"	20.0	M.S.	4 1/2"	30.0	M.S.	4 1/2"	40.0	M.S.
5"	6.0	M.S.	5"	13.0	M.S.	5"	20.0	M.S.	5"	30.0	M.S.	5"	40.0	M.S.
6"	6.0	M.S.	6"	13.0	M.S.	6"	20.0	M.S.	6"	30.0	M.S.	6"	40.0	M.S.
8"	6.0	M.S.	8"	13.0	M.S.	8"	20.0	M.S.	8"	30.0	M.S.	8"	40.0	M.S.
10"	6.0	M.S.	10"	13.0	M.S.	10"	20.0	M.S.	10"	30.0	M.S.	10"	40.0	M.S.
12"	6.0	M.S.	12"	13.0	M.S.	12"	20.0	M.S.	12"	30.0	M.S.	12"	40.0	M.S.
14"	6.0	M.S.	14"	13.0	M.S.	14"	20.0	M.S.	14"	30.0	M.S.	14"	40.0	M.S.
16"	6.0	M.S.	16"	13.0	M.S.	16"	20.0	M.S.	16"	30.0	M.S.	16"	40.0	M.S.
18"	6.0	M.S.	18"	13.0	M.S.	18"	20.0	M.S.	18"	30.0	M.S.	18"	40.0	M.S.
20"	6.0	M.S.	20"	13.0	M.S.	20"	20.0	M.S.	20"	30.0	M.S.	20"	40.0	M.S.
22-1/2"	6.0	M.S.	22-1/2"	13.0	M.S.	22-1/2"	20.0	M.S.	22-1/2"	30.0	M.S.	22-1/2"	40.0	M.S.
24"	6.0	M.S.	24"	13.0	M.S.	24"	20.0	M.S.	24"	30.0	M.S.	24"	40.0	M.S.

TIE ROD

90° BEND

45° BEND

**NOTES:**

- LENGTH OF TIED PIPE MEASURED EACH WAY FROM VALVES AND BENDS.
- CLAMPS AND RODS NOT ALLOWED FOR 24" AND LARGER PIPES.
- D = DIAMETER, L = LENGTH, G = GRADE, M.S. = MILD STEEL, H.S. = HIGH STRENGTH.
- MINIMUM 4.5' GROUND COVER REQUIRED.
- BASED ON 150 PSI INTERNAL PRESSURE.
- M.S. MEANS MILD STEEL ROD A.S.T.M. STANDARD DESIGNATION A-36.
- H.S. MEANS HIGH STRENGTH ROD A.S.T.M. STANDARD DESIGNATION A-307 GRADE A OR B HEXAGON HEAVY SERIES.
- NUTS SHALL BE A.S.T.M. STANDARD DESIGNATION A-307 GRADE A OR B HEXAGON HEAVY SERIES.
- CLAMP METALS AND SET CLAMP DETAILS SHALL BE AS SHOWN. SEE THE ROD COUPLING DETAILS.
- LENGTH REFERS TO THE AMOUNT OF PIPE WHICH MUST BE TIED TOGETHER AND IS NOT NECESSARILY THE LENGTH OF THE RODS.
- STAR BOLTS NOT ALLOWED ON PIPE LARGER THAN 16".
- MINIMUM OF 4 RODS REQUIRED ON 16" PIPE IF STAR BOLTS ARE USED.
- TEES ARE TO BE RODED ON BRANCH ONLY.
- ALL VALVES TO BE RODED IN BOTH DIRECTIONS.

STONEGATE VILLAGE METROPOLITAN DISTRICT

LENGTH OF TIED PIPE

SCALE: NONE DATE: 4/00

APPROVED: R/JG DISTRICT ENGINEER

TIE ROD DETAIL

WASHER DETAIL

ROD DIAMETER	THREAD	ROD LENGTH
3/4"	ALL THREAD	10 11 8 20
1"	ALL THREAD	10 11 8 20

WIDTH	HOLE DIAMETER	LENGTH	THICKNESS
3"	3/8"	6"	3/8"
4"	1/2"	7"	1/2"
6"	3/4"	9"	3/8"

**NOTES:**

- SEE TIED JOINTS ROD DIMENSIONS SHEET.
- SEE CLAMP DETAILS AND DIMENSIONS SHEET 23 FOR PROPER PLACEMENT OF WASHERS.

STONEGATE VILLAGE METROPOLITAN DISTRICT

TIE ROD AND WASHER DETAILS

SCALE: NONE DATE: 4/00

APPROVED: R/JG DISTRICT ENGINEER

TIE ROD COUPLING DETAIL

SECTION "A-A"

NOTE: BLACK IRON PIPE = SCHEDULE 40.

ROD SIZE	PIPE DIAMETER
3/4"	1"
1"	1-1/4"
1-1/4"	1-1/2"

STONEGATE VILLAGE METROPOLITAN DISTRICT

TIE ROD COUPLING

SCALE: NONE DATE: 4/00

APPROVED: R/JG DISTRICT ENGINEER

FLANGE LUG DETAIL

DIMENSIONS (IN INCHES)

PIPE DIA.	N	O	H.S. ROD			M.S. ROD			R	S	U	V	PIPE DIA.
			P	Q	ROD DIA.	P	Q	ROD DIA.					
4"	13/16"	2 1/4"	7/8"	3/4"	7/8"	3/4"	7/8"	3/4"	1 1/2"	1 1/2"	1 1/2"	3/4"	4"
6"	2 1/4"	3 1/4"	7/8"	3/4"	7/8"	3/4"	7/8"	3/4"	1 1/2"	1 1/2"	1 1/2"	3/4"	6"
8"	2 3/4"	3 3/4"	7/8"	3/4"	7/8"	3/4"	7/8"	3/4"	1 1/2"	1 1/2"	1 1/2"	3/4"	8"
10"	3 1/4"	4 1/4"	7/8"	3/4"	7/8"	3/4"	7/8"	3/4"	1 1/2"	1 1/2"	1 1/2"	3/4"	10"
12"	3 3/4"	4 3/4"	7/8"	3/4"	7/8"	3/4"	7/8"	3/4"	1 1/2"	1 1/2"	1 1/2"	3/4"	12"
14"	4 1/4"	5 1/4"	7/8"	3/4"	7/8"	3/4"	7/8"	3/4"	1 1/2"	1 1/2"	1 1/2"	3/4"	14"
16"	4 3/4"	5 3/4"	7/8"	3/4"	7/8"	3/4"	7/8"	3/4"	1 1/2"	1 1/2"	1 1/2"	3/4"	16"
18"	5 1/4"	6 1/4"	7/8"	3/4"	7/8"	3/4"	7/8"	3/4"	1 1/2"	1 1/2"	1 1/2"	3/4"	18"
20"	5 3/4"	6 3/4"	7/8"	3/4"	7/8"	3/4"	7/8"	3/4"	1 1/2"	1 1/2"	1 1/2"	3/4"	20"

**NOTES:**

- M.S. MEANS MILD STEEL ROD A.S.T.M. STANDARD DESIGNATION A-36. (NUTS SHALL BE A.S.T.M. STANDARD DESIGNATION A-307 GRADE A OR B HEXAGON HEAVY SERIES).
- H.S. MEANS HIGH STRENGTH STEEL ROD A.S.T.M. STANDARD DESIGNATION A-193 GRADE 87. (NUTS SHALL BE A.S.T.M. STANDARD DESIGNATION A-194 GRADE 2H).
- FLANGE LUGS SHALL NOT BE USED ON VALVES.

STONEGATE VILLAGE METROPOLITAN DISTRICT

FLANGE LUG DETAIL

SCALE: NONE DATE: 4/00

APPROVED: R/JG DISTRICT ENGINEER

### PIPE BEDDING

(a) Installation of Bedding and Pipe: After completion of the trench excavation and proper preparation of the foundation, six inches (6") of bedding material shall be placed on the trench bottom for support under the pipe. Bed holes shall be dug deep enough to provide a minimum of two inches (2") of clearance between the bed and bedding material. All pipe shall be installed in such a manner as to insure full support of the pipe barrel over its entire length. After the pipe is adjusted for line and grade, and the joint is made, the bedding material shall be carefully placed and tamped under the haunches of the pipe and in the previously dug bed holes.

Tamping is herein defined as the act of placing approved bedding material under the haunches of the pipe, paying particular attention to voids, bell holes, and silt holes. The purpose of tamping is to ensure uniform support for the pipe.

The limits of bedding shall be from six inches (6") below the bottom of the pipe to twelve inches (12") above the top of the pipe. Approved backfill may then be installed to the groundline. See Section 8 of these Standards for backfill and composition of backfill.

Compaction of bedding is not required. The only requirement is sufficient tamping to achieve uniform support under the pipe. See Sheet 8 of the Standard Drawings for a typical trench cross section.

(b) Bedding Material: The bedding material shall be a clean well-graded sand or silt-sand and shall conform to the following limits when tested by means of laboratory sieves:

Well-Graded Sand	
Sieve Size	Total Percent Passing by Weight
3/8 inch	100
No. 4	95-100
No. 8	80-100
No. 16	50-85
No. 30	25-60
No. 50	10-30
No. 100	2-10
No. 200	0

Sieve Sand	
Sieve Size	Total Percent Passing by Weight
3/8 inch	100
No. 100	0-5

If approved by the District, fines from the trench walls and spoils pile may be used to provide uniform support for the pipe. No rock or stone larger than that allowed by the sieve analysis, or any other detrimental substance, shall be placed closer to the pipe than six inches (6"). Approved bedding materials shall be stockpiled on the jobsite to be used in the event natural materials become unsatisfactory. The District reserves the right to require the use of the specified bedding material at any time.

STONEGATE VILLAGE METROPOLITAN DISTRICT

PIPE BEDDING

SCALE: NONE DATE: 4/00

APPROVED: R/JG DISTRICT ENGINEER

IMPROPER WASHER PLACEMENT

PROPER WASHER PLACEMENT (FOR WASHER DIMENSIONS SEE TIE ROD AND WASHER DETAILS SHEET 19)

NOTE: ALL BOLT HOLES TO BE 1/8" LARGER DIA. THAN BOLT

CLAMP DETAILS

DIMENSIONS

PIPE DIA.	BAR SIZE	A	B	C	D	E	F	G	H	I	J	K	L	M	N	O	P	PIPE DIA.
4"	1-1/2"	9-3/4"	7-1/2"	3-1/2"	3-1/2"	1	1	6-3/4"	4-7/8"	2-3/4"	1-13/16"	1-1/4"	1-1/4"	3x1/2"	2-1/2x3/8"	4	4	4"
6"	2x1/2"	13	9-1/2"	4	4-1/2"	2	2	10-1/4"	7-7/8"	4-1/8"	2-19/16"	2	1-1/4"	3-1/2x1/2"	3-1/2x1/2"	6	6"	
8"	2-1/2x1/2"	15	12-3/4"	4-3/4"	4-1/2"	1-1/4"	1-1/2"	12-1/4"	9-1/4"	5-1/8"	4	2	1-1/4"	4-1/2x1/2"	4-1/2x1/2"	8	8"	
12"	2-1/2x5/8"	17-1/2"	16-3/8"	4-5/8"	4-3/4"	1	1-1/4"	14-1/2"	11-1/2"	6	5-1/2"	2-1/2"	2-1/2"	4-1/2x5/8"	4-1/2x5/8"	12	12"	
16"	3x3/4"	24-1/2"	21-7/8"	4-1/2"	4-3/4"	1-1/2"	1-1/2"	19-3/4"	17-1/2"	8-3/8"	7-1/2"	3	2-1/2"	5-1/2x5/8"	5-1/2x5/8"	16	16"	
20"	3x3/4"	32-1/2"	29-5/8"	4-1/2"	4-3/4"	1-1/2"	1-1/2"	24-3/4"	21-3/4"	10-7/8"	9-1/2"	3	2-3/4"	5-1/2x5/8"	5-1/2x5/8"	20	20"	
24"																		24"

NOTE: ALL DIMENSIONS IN INCHES. CLAMPS MAY NOT BE USED ON PVC PIPE.

STONEGATE VILLAGE METROPOLITAN DISTRICT

CLAMP DETAILS AND DIMENSIONS

SCALE: NONE DATE: 4/00

APPROVED: R/JG DISTRICT ENGINEER

TOP VIEW

SIDE VIEW

HARNES LUG DIMENSIONS

CARRIER PIPE NOMINAL DIA.	STUD DIA.	A	W	Z	T	H	E	H1	Y	X
4" TO 16"	3/4"	5"	1-1/2"	3-3/4"	3/8"	4-1/8"	3-1/8"	2"	4-1/2"	5"
20"	1"	5-3/4"	1-3/4"	4-7/16"	3/8"	4-1/2"	3-1/4"	2"	5-1/4"	5-11/16"

**NOTES:**

- USE TWO HIGH STRENGTH STEEL TIE RODS AT END OF CASING.
- TIE ROD HOLE DIAMETER 1/8" LARGER THAN STUD DIAMETER.
- BOTTOM EDGE OF ALL PLATES SHAPED TO FIT O.D. OF PIPE.

STONEGATE VILLAGE METROPOLITAN DISTRICT

HARNES LUG DETAILS

SCALE: NONE DATE: 4/00

APPROVED: R/JG DISTRICT ENGINEER

SEWER CROSSING UNDER (WITH "D" LESS THAN 2')

SECTION A-A

**NOTES:**

- ANY SUBDRAIN UNDER THE SEWER SHALL BE REPLACED SUCH THAT NO FLOW SHALL ENTER THE WATER LINE TRENCH.

STONEGATE VILLAGE METROPOLITAN DISTRICT

CROSSING STORM & SANITARY SEWERS

SCALE: NONE DATE: 4/00

APPROVED: R/JG DISTRICT ENGINEER

REV	DESCRIPTION	DATE	BY	CHKD	APPD
0	ISSUED FOR CONSTRUCTION	7/19/2024			



THE USE OF ANY OTHER MATERIALS OR METHODS OF CONSTRUCTION IS AN INSTRUMENT OF SERVICE PROVIDED BY MERRICK AND COMPANY, INC. A REVIEW PROJECT, REUSE OR MODIFICATION OF ANY INFORMATION NOT A PART OF THIS PROJECT OR PART OF AN EXTENSION OF THE PROJECT OR ON ANY OTHER PROJECT SHALL BE AT THE USER'S RISK. THE USER SHALL BE RESPONSIBLE FOR OBTAINING ALL NECESSARY PERMITS AND APPROVALS FROM ALL APPLICABLE AGENCIES.

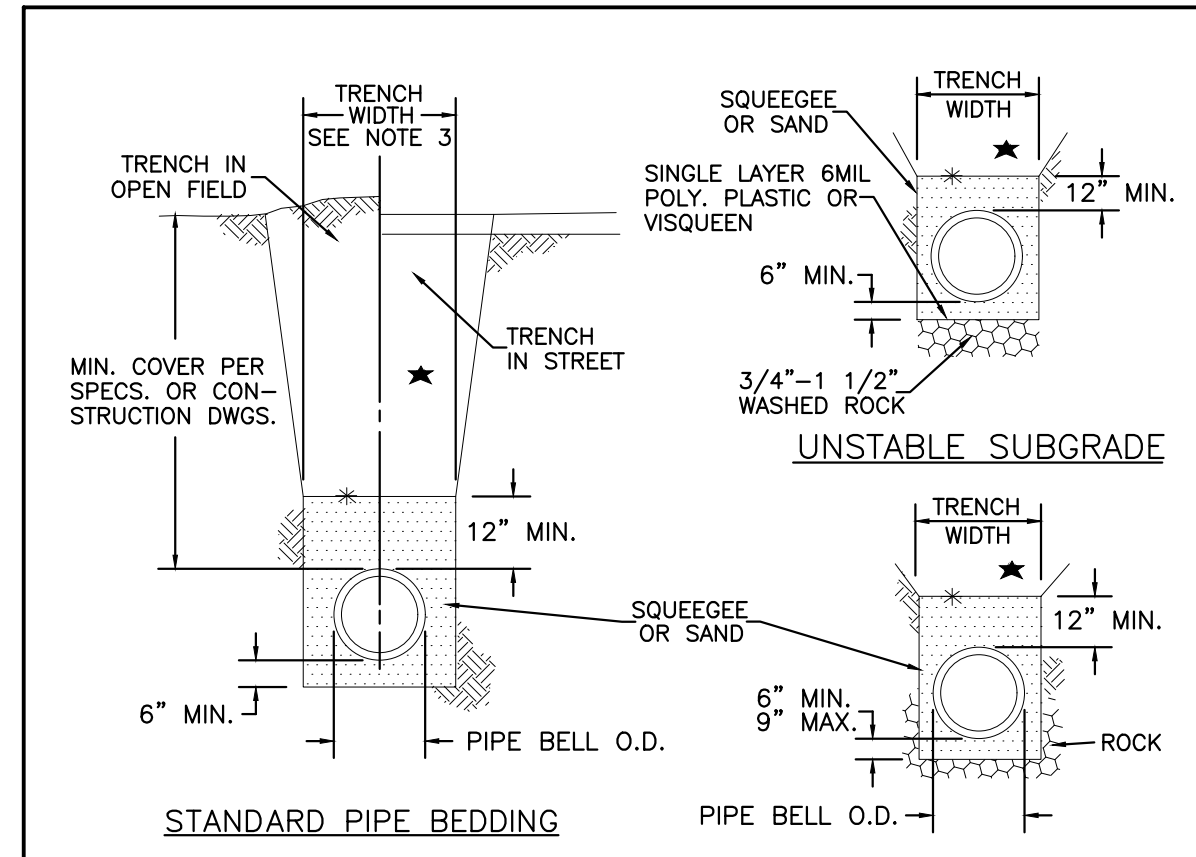

- STANDARD PIPE BEDDING**
- ★ MACHINE COMPACTED TRENCH BACKFILL
  - \* LIMIT OF SLOPING OR BENCHING OF TRENCH WALLS
  - UNDISTURBED GROUND
- PIPE BEDDING IN ROCK**
- NOTES:**
1. MIN. COVER TO BE BELOW FINAL STREET GRADE WHEN AVAILABLE.
  2. TRENCH TO BE BRACED OR SHEETED AS NECESSARY FOR THE PROTECTION OF OTHER UTILITIES AND TO MEET OSHA SAFETY REQUIREMENT.
  3. TRENCH WIDTH SHALL NOT BE MORE THAN 16" NOR LESS THAN 12" WIDER THAN THE LARGEST OUTSIDE DIAMETER OF THE PIPE LAID THEREIN (BELL OR COUPLING O.D. IF APPLICABLE).

STONEGATE VILLAGE METROPOLITAN DISTRICT  
**BEDDING DETAILS**

SCALE: NONE DATE: 4/00

APPROVED: R/JG DISTRICT ENGINEER

2000 REVISION SHEET 29

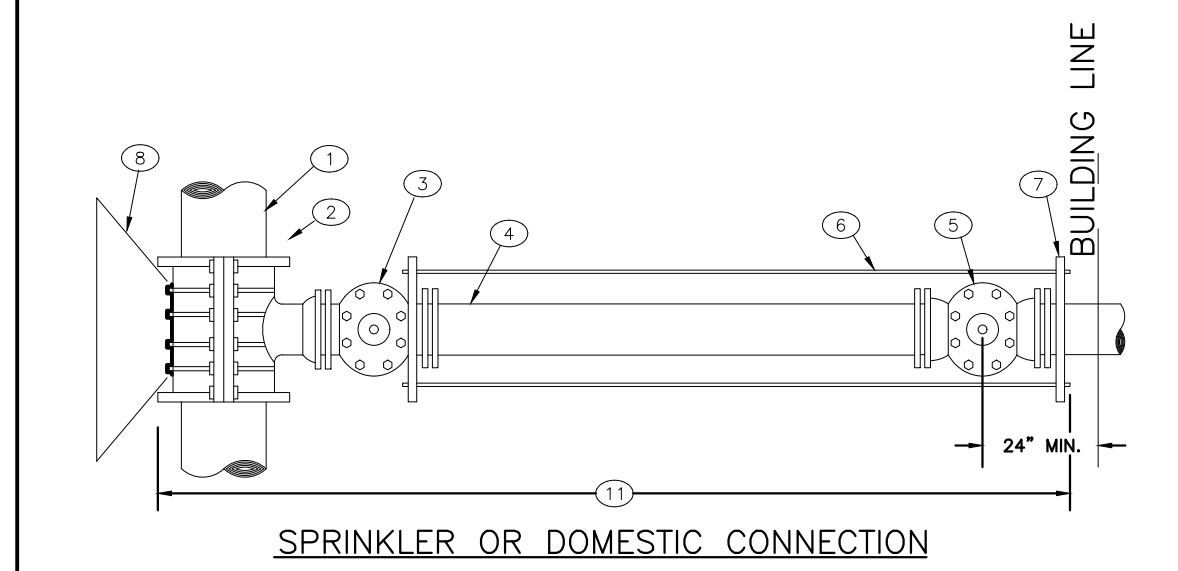
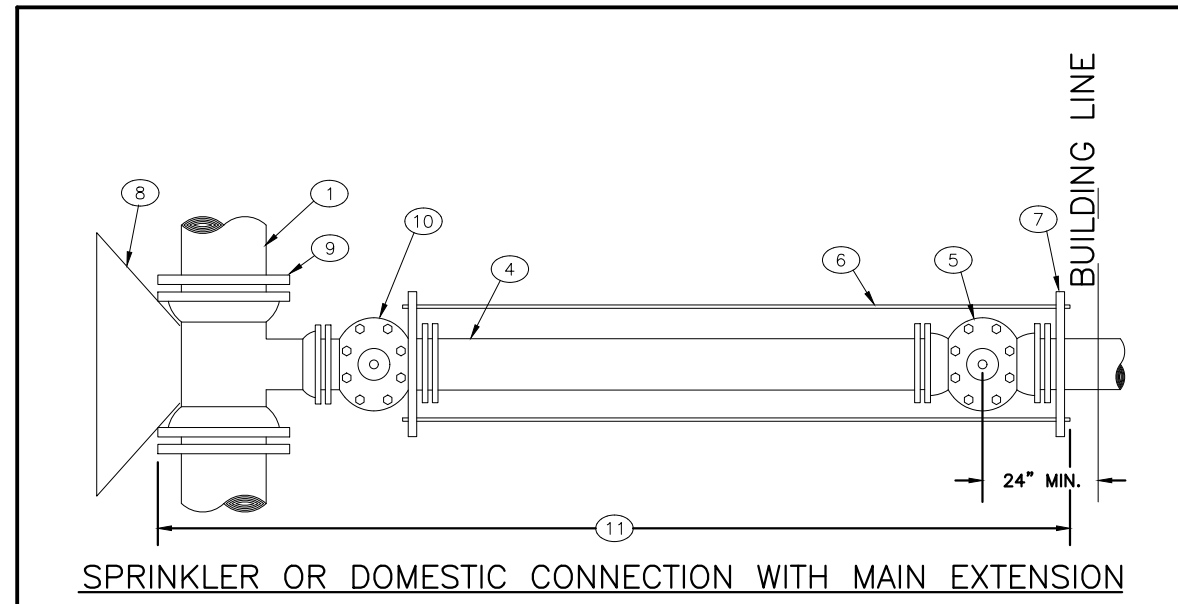

STONEGATE VILLAGE METROPOLITAN DISTRICT  
**3" AND LARGER DOMESTIC AND SPRINKLER CONNECTIONS**

SCALE: NONE DATE: 4/00

APPROVED: R/JG DISTRICT ENGINEER

LEGEND:  
1 EXISTING MAIN  
2 TAPPING SLEEVE  
3 TAPPING VALVE  
4 DOUBLE SPIGOT PIPE  
5 PROPERTY LINE VALVE  
6 TIE RODS  
7 PIPE CLAMP  
8 CONCRETE KICKBLOCK  
9 M.J. ANCHORING TEE (SWIVEL TEE)  
10 M.J. VALVE  
11 POLYETHYLENE WRAPPED

2000 REVISION SHEET 31

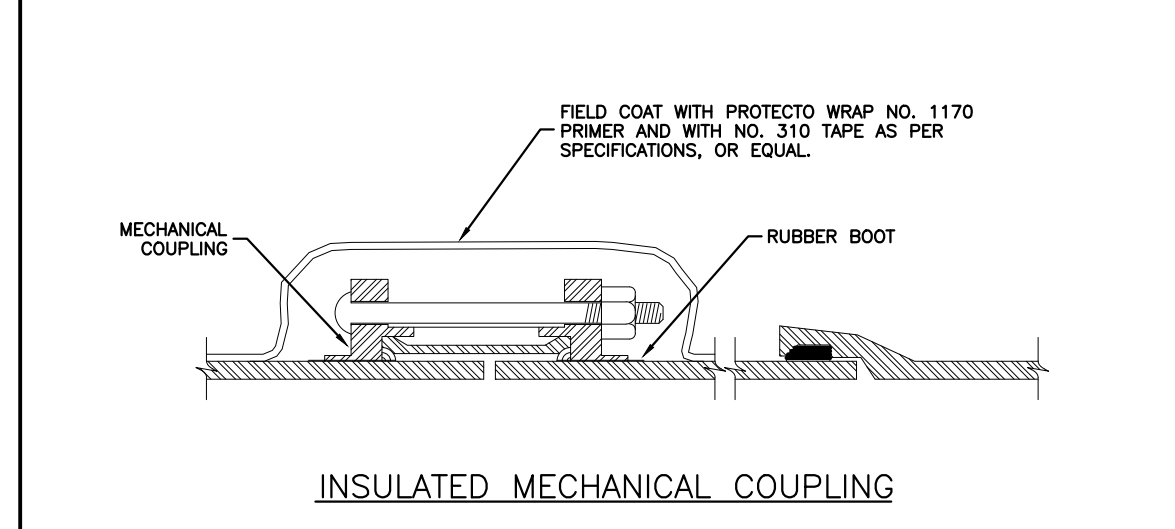
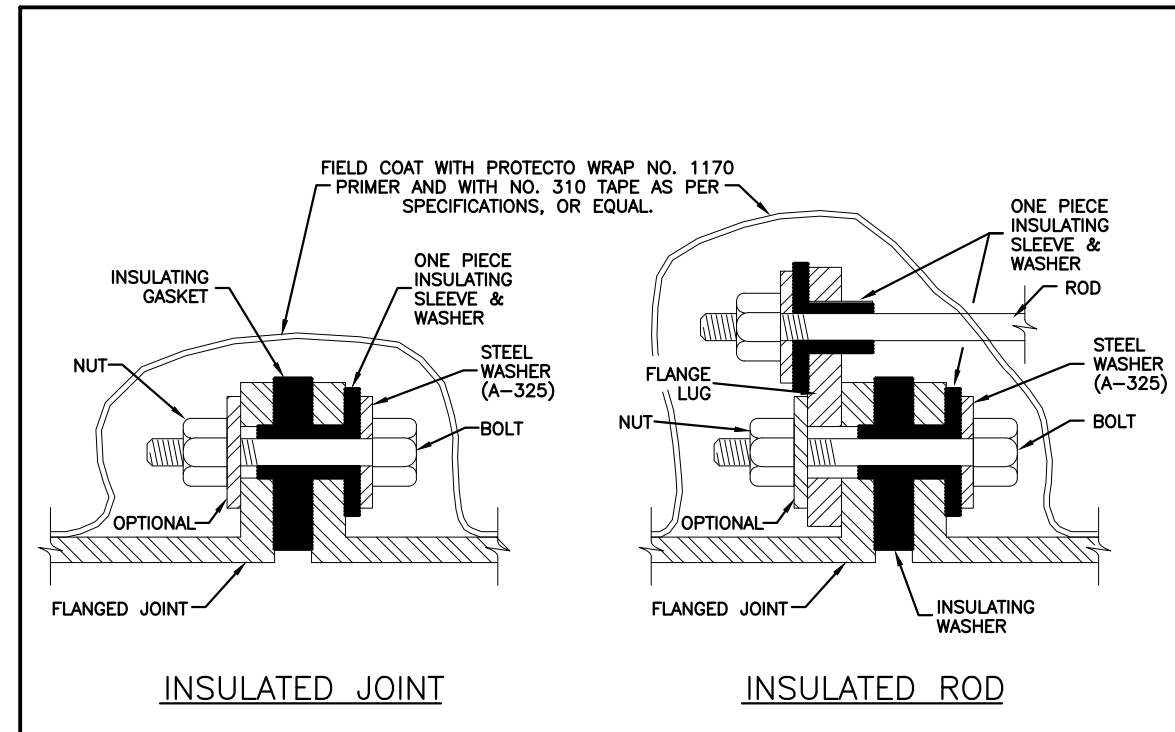

STONEGATE VILLAGE METROPOLITAN DISTRICT  
**INSULATED JOINTS, RODS AND MECHANICAL COUPLINGS**

SCALE: NONE DATE: 4/00

APPROVED: R/JG DISTRICT ENGINEER

2000 REVISION SHEET 32

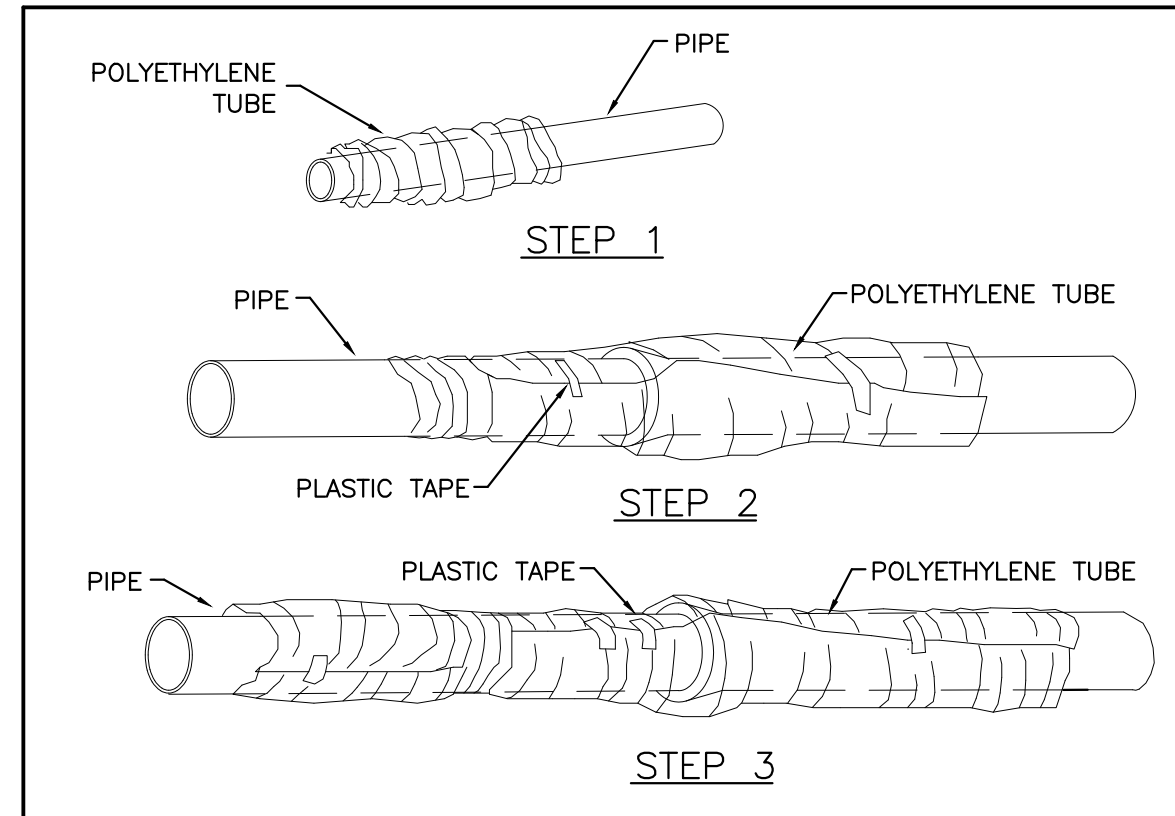

- FIELD INSTALLATION - POLYETHYLENE WRAP**
- STEP 1 - PLACE TUBE OF POLYETHYLENE MATERIAL ON PIPE PRIOR TO LOWERING IT INTO TRENCH.**
- STEP 2 - PULL THE TUBE OVER THE LENGTH OF THE PIPE. TAPE TUBE TO PIPE AT JOINT. FOLD MATERIAL AROUND THE ADJACENT SPIGOT END AND WRAP WITH TAPE TO HOLD THE PLASTIC TUBE IN PLACE.**
- STEP 3 - OVERLAP FIRST TUBE WITH ADJACENT TUBE AND SECURE WITH PLASTIC ADHESIVE TAPE. THE POLYETHYLENE TUBE MATERIAL COVERING THE PIPE SHALL BE LOOSE. EXCESS MATERIAL SHALL BE NEATLY DRAWN UP AROUND THE PIPE BARREL, FOLDED ON TOP OF PIPE AND TAPED IN PLACE.**

STONEGATE VILLAGE METROPOLITAN DISTRICT  
**POLYETHYLENE WRAP**

SCALE: NONE DATE: 4/00

APPROVED: R/JG DISTRICT ENGINEER

2000 REVISION SHEET 33

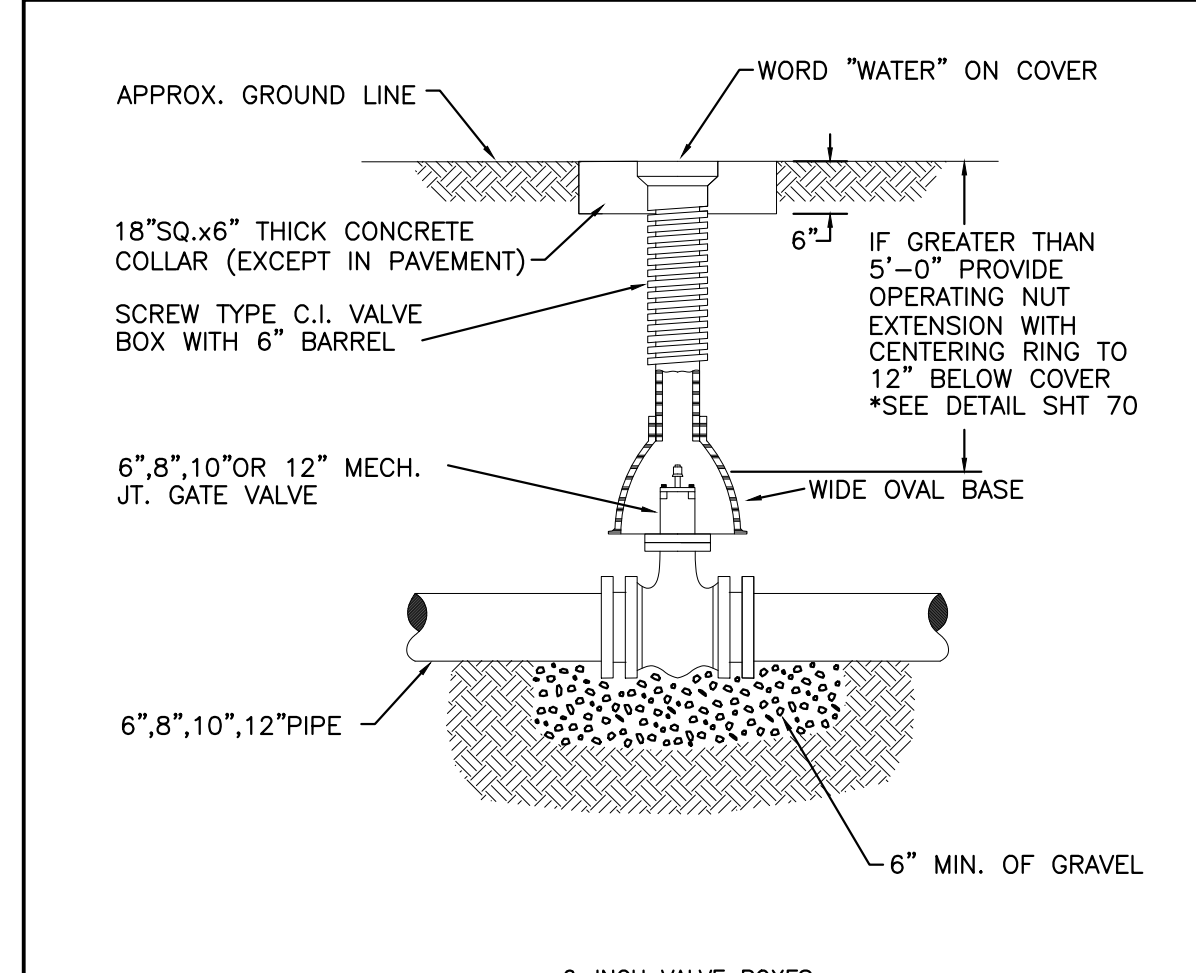

- Materials:**  
Valve box parts shall be made from gray cast iron, ASTM A48 Class 20A. Use of an aluminum alloy as a casting material is not acceptable.
- Approved Patterns:**  
Valve boxes shall be the three-piece adjustable screw type and the following two patterns are acceptable.
1. Tyler screw-type 6-inch cast iron valve box assembly series 6860 with No. 160 oval base.
  2. Clay and Bailey screw-type 6-inch cast iron valve box assembly No. P-105 with No. 160 large oval base.

STONEGATE VILLAGE METROPOLITAN DISTRICT  
**VALVE BOX DETAIL**

SCALE: NONE DATE: 4/00

APPROVED: R/JG DISTRICT ENGINEER

2000 REVISION SHEET 34

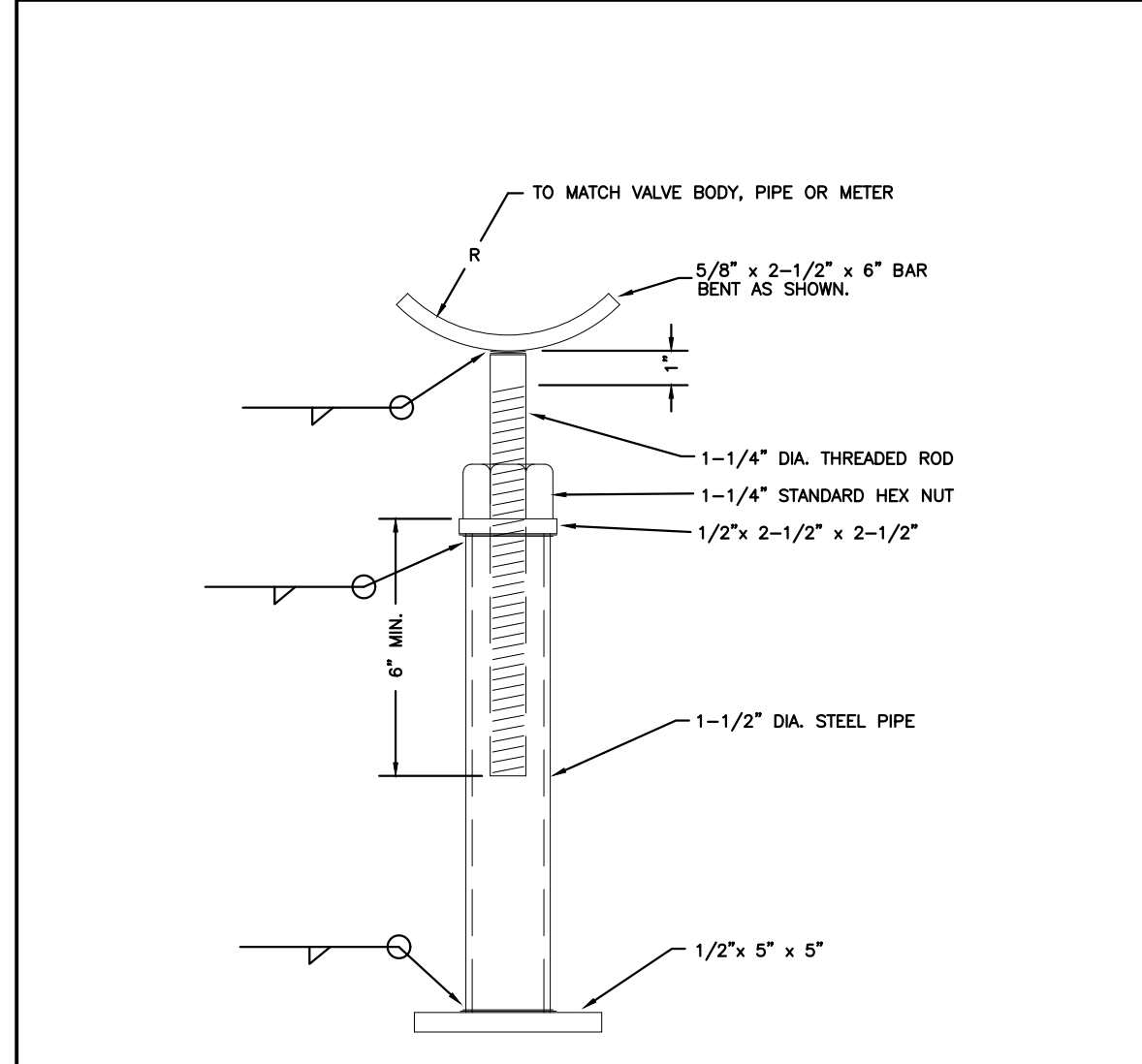

STONEGATE VILLAGE METROPOLITAN DISTRICT  
**ADJUSTABLE STEEL PIPE VALVE SUPPORT**

SCALE: NONE DATE: 4/00

APPROVED: R/JG DISTRICT ENGINEER

2000 REVISION SHEET 35

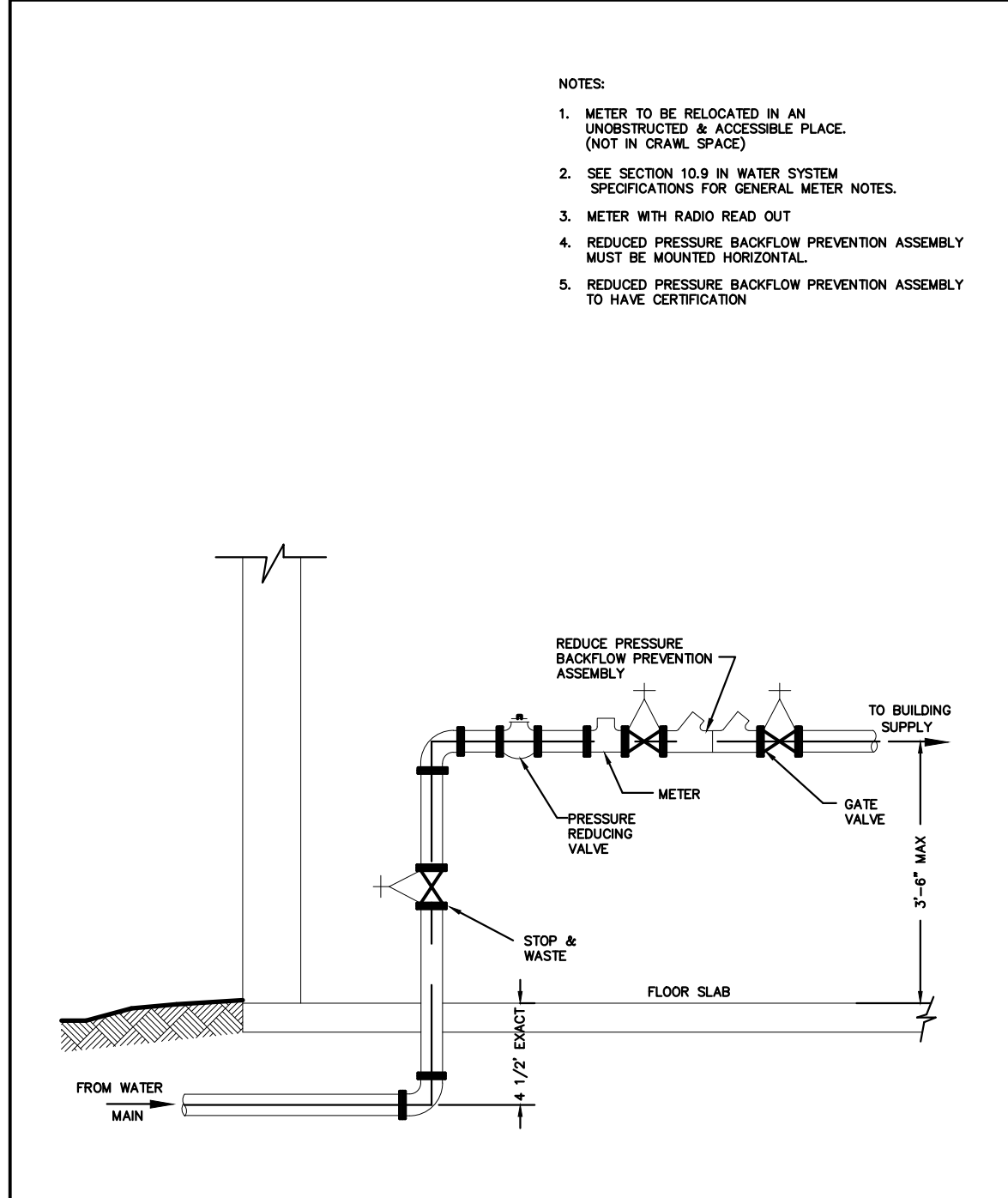

STONEGATE VILLAGE METROPOLITAN DISTRICT  
**INSIDE COMMERCIAL METER INSTALLATION FOR 6" & SMALLER PIPE**

SCALE: NONE DATE: 4/00

APPROVED: R/JG DISTRICT ENGINEER

2000 REVISION SHEET 43

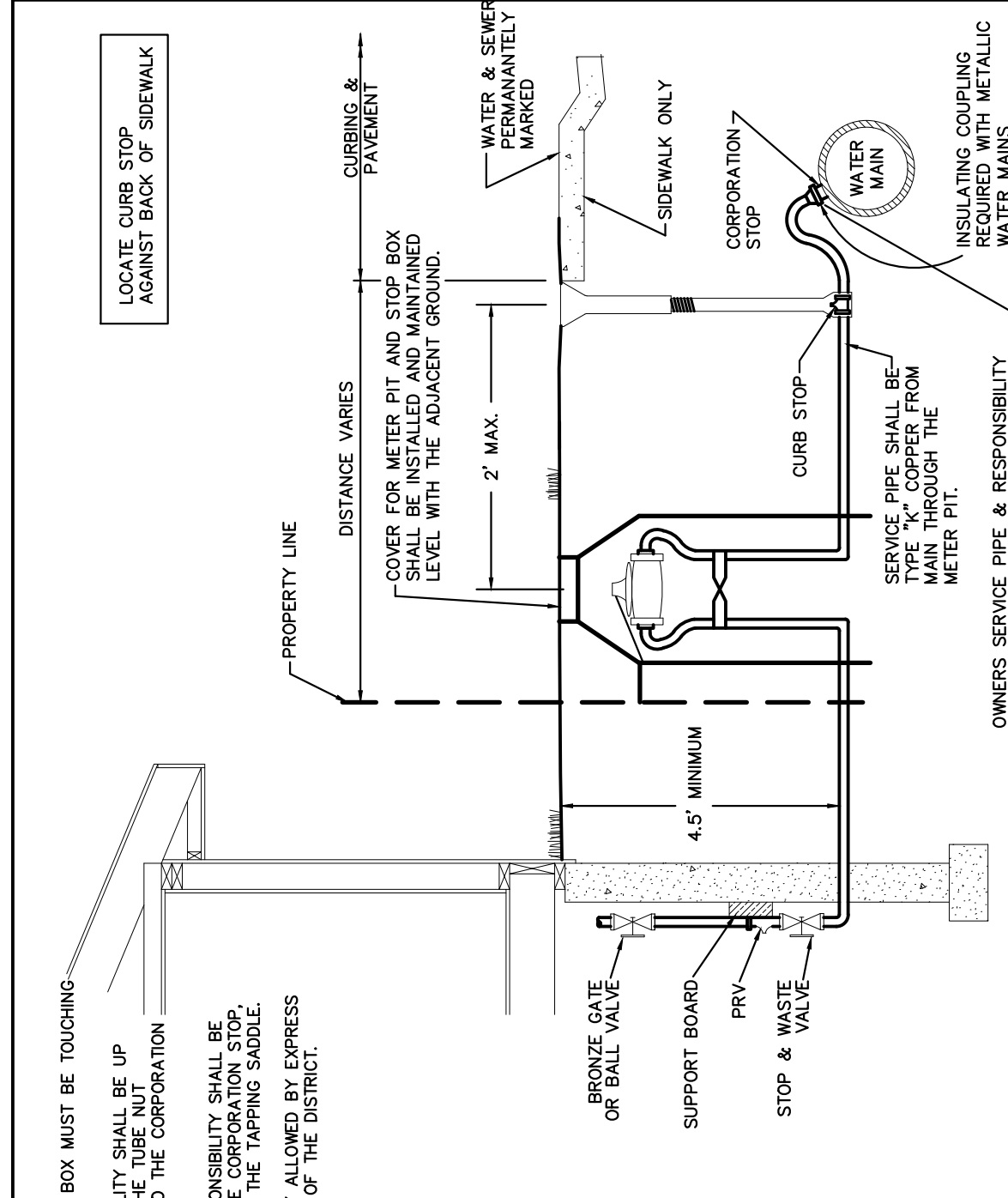

STONEGATE VILLAGE METROPOLITAN DISTRICT  
**SERVICE LINE, STOP BOX AND OUTSIDE METER INSTALLATION**

SCALE: NONE DATE: 9/2010

APPROVED: SB DISTRICT ENGINEER

2000 REVISION SHEET 44

REV	REVISION DESCRIPTION	DATE	CHKD	APPD
0	ISSUED FOR CONSTRUCTION	7/19/2024		

**COMPARK VILLAGE SOUTH**  
WATER AND SANITARY PLANS  
STANDARD DETAILS - WATER

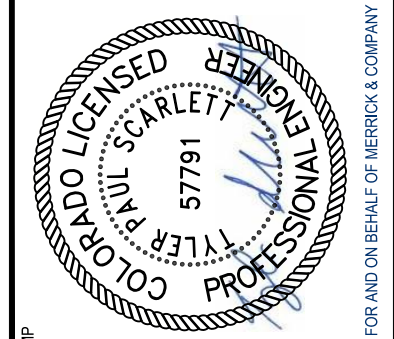

THE USE OF ANY OTHER MATERIALS OR EQUIPMENT IS AN INSTRUMENT OF SERVICE PROVIDED BY MERRICK AND COMPANY, FOR A SPECIFIC PROJECT. IT IS NOT INTENDED OR REPRESENTED TO BE SUITABLE FOR USE IN ANY OTHER PROJECT OR PART OF THE PROJECT OR ON ANY OTHER PROJECT. REUSE OR MODIFICATION OF ANY INSTRUMENT OF SERVICE WITHOUT THE WRITTEN CONSENT OF MERRICK AND COMPANY SHALL BE AT THE USER'S RISK AND WITHOUT LIABILITY TO MERRICK AND COMPANY.

**GENERAL NOTES:**

- NOT FOR INSTALLATION IN ROADWAYS, OR PARKING AREAS.
- IF SURFACE IS NOT TO FINAL GRADE AT TIME OF INSTALLATION OF METER, OWNER MUST RAISE OR LOWER PIT WHEN SURFACE IS GRADED.
- METER SETTING MUST BE INSPECTED BY THE DISTRICT BEFORE BACKFILLING.
- LOCATION OF METER TO BE ESTABLISHED BY A DISTRICT REPRESENTATIVE.
- NO CONCRETE FLOOR TO BE LAID IN METER PIT.
- METER PIT SHALL BE CONSTRUCTED OF FOUR 12", OR ONE 12" AND ONE 36" RINGS. WALLS SHALL BE 2" THICK.
- ADJUSTMENT RINGS SHALL BE 2", 3" 4" OR 6" IN HEIGHT AND SHALL BE INSERTED BETWEEN THE TOP TWO RINGS.
- NO CONNECTIONS OR CHANGES IN PIPE DIAMETER SHALL BE MADE IN THE METER PIT OR IN THE DISTANCE OF FIVE FEET BEYOND THE METER PIT WALL ON THE OUTLET SIDE.
- LAWN SPRINKLER CONNECTION SHALL BE A MINIMUM OF FIVE FEET FROM THE METER PIT WALL ON THE OUTLET SIDE.
- THIS DETAIL TO BE USED ONLY WITH EXPRESS PERMISSION OF THE DISTRICT.
- THE FORD TANDEM COPPERSETTER TO HOLD A WATTS USB PRESSURE REGULATOR (PRV) JUST AHEAD OF THE WATER METER.
- (JUMPER OR CHEATER) PIPES TO BE REMOVED BEFORE METER SET DATE.

METER SIZE	A	B	C
5/8" x 3/4"	12 5/8"	7 1/2"	4"
3/4"	14 1/4"	9 5/16"	5"
1"	17 1/4"	11 1/16"	6"

STONEGATE VILLAGE METROPOLITAN DISTRICT  
ALL OUTSIDE SETTING FOR 5/8" x 3/4", 3/4" & 1" METERS w/ PRV

SCALE: NONE DATE: 4/00  
APPROVED: R/JG DISTRICT ENGINEER

2000 REVISION SHEET 45

**NOTES:**

- ALL CONCRETE SHALL HAVE A 28 DAY STRENGTH OF 3,000 PSI USING TYPE 1 PORTLAND CEMENT AND 3/4" AGGREGATE. ALL CONCRETE SHALL HAVE 5-7% ENTRAINED AIR CONTENT AND A MAXIMUM SLUMP OF 4".
- ALL REINFORCEMENT SHALL CONFORM TO ASTM A615, GRADE 60.
- ALL REINFORCEMENT SHALL HAVE 2" MIN. CONCRETE COVER.
- THE SUBGRADE SHALL BE COMPACTED TO 95% OF THE MAXIMUM STANDARD PROCTOR DENSITY PRIOR TO FORMING THE STRUCTURE.

STONEGATE VILLAGE METROPOLITAN DISTRICT  
WATERLINE ENCASUREMENT

SCALE: NONE DATE: 4/00  
APPROVED: R/JG DISTRICT ENGINEER

2000 REVISION SHEET 48

**NOTES:**

- MANHOLE BASE BEAMS SHALL BE REQUIRED FOR INSTALLATIONS IN DRIVEWAYS, OR PARKING AREAS.
- 4" 45° CONCENTRIC MANHOLE FIT WILL ACCOMMODATE 1 1/2" AND 2" SPLIT BASE METERS.
- JOINTS INSIDE METER VAULT SHALL BE EITHER THREADED OR SOLDERED WITH 95-5 TINANTIMONY SOLDER.
- SEE SECTION 10.9, WATER SYSTEM SPECIFICATIONS FOR GENERAL METER NOTES.
- NO CONCRETE TO BE LAID IN FLOOR OF METER M.H.
- METER SHALL BE FLANGED WITH BRASS COMPANION FLANGES.
- NO CONNECTIONS OR CHANGES IN PIPE DIAMETER SHALL BE MADE IN THE METER PIT OR IN THE DISTANCE OF FIVE FEET BEYOND THE METER PIT ON THE OUTLET SIDE.
- LADDER RINGS SHALL BE ON OPPOSITE SIDE OF BYPASS.
- (JUMPER OR CHEATER) PIPES TO BE REMOVED BEFORE METER SET DATE.

STONEGATE VILLAGE METROPOLITAN DISTRICT  
OUTSIDE SETTING FOR 1 1/2" & 2" METER FOR IRRIGATION

SCALE: NONE DATE: 4/00  
APPROVED: R/JG DISTRICT ENGINEER

2000 REVISION SHEET 49

**NOTES:**

- PIPE JOINT SHALL BE THREADED OR SOLDERED WITH SILVER SOLDER.
- INSTALLATION MUST ALLOW ACCESS FOR MAINTENANCE AND BE PROTECTED FROM FREEZING.
- SEE SECTION 10.9, WATER SYSTEM SPECIFICATIONS FOR GENERAL METER NOTES.
- COMPANION FLANGES SHALL BE BRASS.
- METER SUPPORT SHALL BE EITHER CONCRETE OR ADJ. STEEL PIPE (SEE SHEET NO. 34)
- THIS DETAIL TO BE USED ONLY WITH EXPRESS PERMISSION OF THE DISTRICT ENGINEER.

STONEGATE VILLAGE METROPOLITAN DISTRICT  
INSIDE SETTING FOR 1 1/2" & 2" METER WITH CHECK VALVE

SCALE: NONE DATE: 4/00  
APPROVED: R/JG DISTRICT ENGINEER

2000 REVISION SHEET 51

**VALVE OPENING & CLOSING PROCEDURE**

STONEGATE VILLAGE METROPOLITAN DISTRICT  
VALVE OPERATION

SCALE: NONE DATE: 4/00  
APPROVED: R/JG DISTRICT ENGINEER

2000 REVISION SHEET 61

NOMINAL PIPE SIZE	NO. OF BOLTS	NO. OF WEDGES	K2 INCHES	J INCHES	F INCHES	M INCHES
4"	2	2				
6"	6	3	11.12	9.5	7.00	0.88
8"	6	4	13.37	11.75	9.15	1.00
10"	8	6	15.62	14.00	11.20	1.00
12"	8	8	17.88	16.25	13.30	1.25
4"	4	2				
6"	6	3	11.12	9.5	7.00	0.88
8"	6	4	13.37	11.75	9.15	1.00
10"	8	6	15.62	14.00	11.20	1.00
12"	8	8	17.88	16.25	13.30	1.25

STONEGATE VILLAGE METROPOLITAN DISTRICT  
MECHANICAL JOINT RESTRAINT DETAILS

SCALE: NONE DATE: 4/00  
APPROVED: R/JG DISTRICT ENGINEER

2000 REVISION SHEET 65

STONEGATE VILLAGE METROPOLITAN DISTRICT  
TYPICAL WATER SERVICES

SCALE: NONE DATE: 4/00  
APPROVED: R/JG DISTRICT ENGINEER

2000 REVISION SHEET 66

**INSPECTION POLICY:**

- ALL SERVICE INSPECTIONS MUST BE SCHEDULED WITH THE DISTRICT ENGINEER (303) 263-3699 AT LEAST 24 HOURS IN ADVANCE OF THE REQUESTED INSPECTION.
- SERVICE INSPECTIONS WILL OCCUR BETWEEN 8:00 A.M. AND 3:00 P.M. SPECIFIC INSPECTION TIMES ARE NOT AVAILABLE.
- IF THE CONTRACTOR IS NOT READY FOR INSPECTION WHEN THE INSPECTOR ARRIVES AT THE SITE, A RE-INSPECTION WILL HAVE TO BE SCHEDULED IN ACCORDANCE WITH NOTES 1 AND 2 ABOVE.
- SHOULD THE SERVICE LINES BE DAMAGED BY LATER CONSTRUCTION, AN INSPECTION OF THE REPAIR WILL BE REQUIRED IN ACCORDANCE WITH NOTES 1 AND 2 ABOVE.
- THE CONTRACTOR SHALL LEAVE ALL PIPE AND FITTINGS EXPOSED FOR THE INSPECTOR TO OBSERVE. INSPECTORS WILL NOT ENTER ANY EXCAVATIONS TO CHECK MATERIALS. THE TOP LAYER OF BEDDING CAN BE ADDED AFTER THE INSPECTION HAS BEEN COMPLETED.
- ALL EXCAVATIONS SHALL BE IN ACCORDANCE WITH OSHA STANDARDS.

**INSTALLATION NOTES:**

**WATER**

- ACCEPTABLE PIPE MATERIALS SHALL BE K-COPPER TUBING. (3/4" MIN.)
- APPROVED BEDDING TO BE SQUEEGEE.
- ONLY ONE COUPLING WILL BE ALLOWED BETWEEN THE STUB-IN AND BUILDING. A COUPLING MAY BE EITHER FLARED OR SILVER-SOLDERED. COMPRESSION COUPLINGS WILL NOT BE ALLOWED. MOVED CURB BOXES MUST BE INSPECTED BY PWSD PRIOR TO BURIAL.
- A WATER SERVICE WHICH CROSSES A SEWER SERVICE CAN DO SO ONLY AT A 90°± ANGLE MAXIMUM, 45° ANGLE MINIMUM. WATER SERVICES SHALL BE LOCATED A MINIMUM OF 18" ABOVE SEWER SERVICE.
- WATER SERVICE FOUNDATION PENETRATIONS SHALL BE WATERPROOFED USING MASTIC OR OTHER APPROVED METHOD.
- STOPBOX MUST BE PLUMB AND CENTERED OVER NUT, AND MUST BE SET AT OR, SLIGHTLY ABOVE FINISHED GRADE.
- STOPBOXES MUST BE SET AT BACK OF SIDEWALK ONLY (TOUCHING) NOT AT CURBS.
- NO CRAWLSPACE MOUNTED METERS ALLOWED.
- WATERLINE MUST BE ATTACHED TO A SUPPORT BOARD THAT IS MOUNTED TO THE WALL.
- NO VOIDS ALLOWED UNDER WATERLINES FROM STOP BOX TO FOUNDATION.
- METER SHOULD BE LOCATED ON SAME SIDE OF HOUSE AS CURBSTOP IF POSSIBLE.
- WATERLINES PASSING UNDER DRIVEWAYS NEED TO BE SLEEVED IN 4" P.V.C. AND HAVE EXPRESS PERMISSION OF THE DISTRICT.
- YOKES SHOULD BE MOUNTED NO GREATER THAN 6 INCHES ABOVE BOTTOM SHUTOFF. EACH SERVICE MUST INCLUDE A STOP AND WASTE VALVE AND A PRESSURE REDUCING VALVE LOCATED WITHIN THE ABOVE REFERENCED 6 INCH SPACE.
- NO SPLICES OR FLARED COUPLINGS ALLOWED ON WATERLINES. SILVER SOLDER JOINTS MUST BE USED IN MOVING STOPBOXES, AND SILVER SOLDER JOINT MUST BE INSPECTED BY PWSD PRIOR TO BURIAL.
- ONLY 3/4" (JUMPER OR CHEATER) PIPES (RESIDENCES) ARE ALLOWED. (JUMPER OR CHEATER) PIPES WILL BE REMOVED PRIOR TO METER SET DATE.
- ALL SERVICES WILL BE PERMANENTLY MARKED ON CURB FACE AS FOLLOWS: "X" FOR SANITARY SEWER SERVICE "W" FOR WATER SERVICES

STONEGATE VILLAGE METROPOLITAN DISTRICT  
DISTRICT POLICIES & INSTALLATION NOTES FOR WATER SERVICES

SCALE: NONE DATE: 4/00  
APPROVED: R/JG DISTRICT ENGINEER

2000 REVISION SHEET 67

NO.	ISSUED FOR CONSTRUCTION	DATE	CHNO/CHDO/APPR
0	ISSUED FOR CONSTRUCTION	7/19/2024	

**COMPARK VILLAGE SOUTH**  
WATER AND SANITARY PLANS  
STANDARD DETAILS - WATER

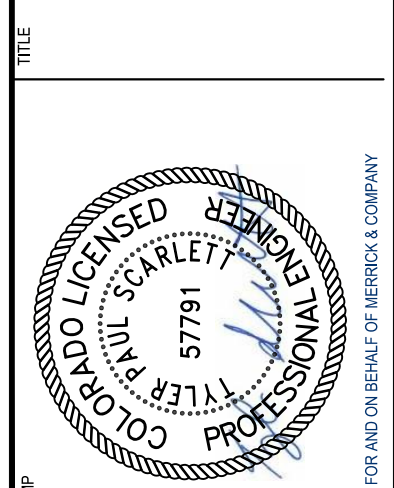



THESE AND ALL OTHERS ARE SUBJECT TO CHANGE WITHOUT NOTICE. ANY CHANGES IN THE DESIGN OR SPECIFICATIONS SHALL BE MADE BY THE DESIGNER. THE USER SHALL BE RESPONSIBLE FOR OBTAINING THE LATEST REVISIONS OF THIS MANUAL. THE USER SHALL BE RESPONSIBLE FOR OBTAINING THE LATEST REVISIONS OF THIS MANUAL. THE USER SHALL BE RESPONSIBLE FOR OBTAINING THE LATEST REVISIONS OF THIS MANUAL.

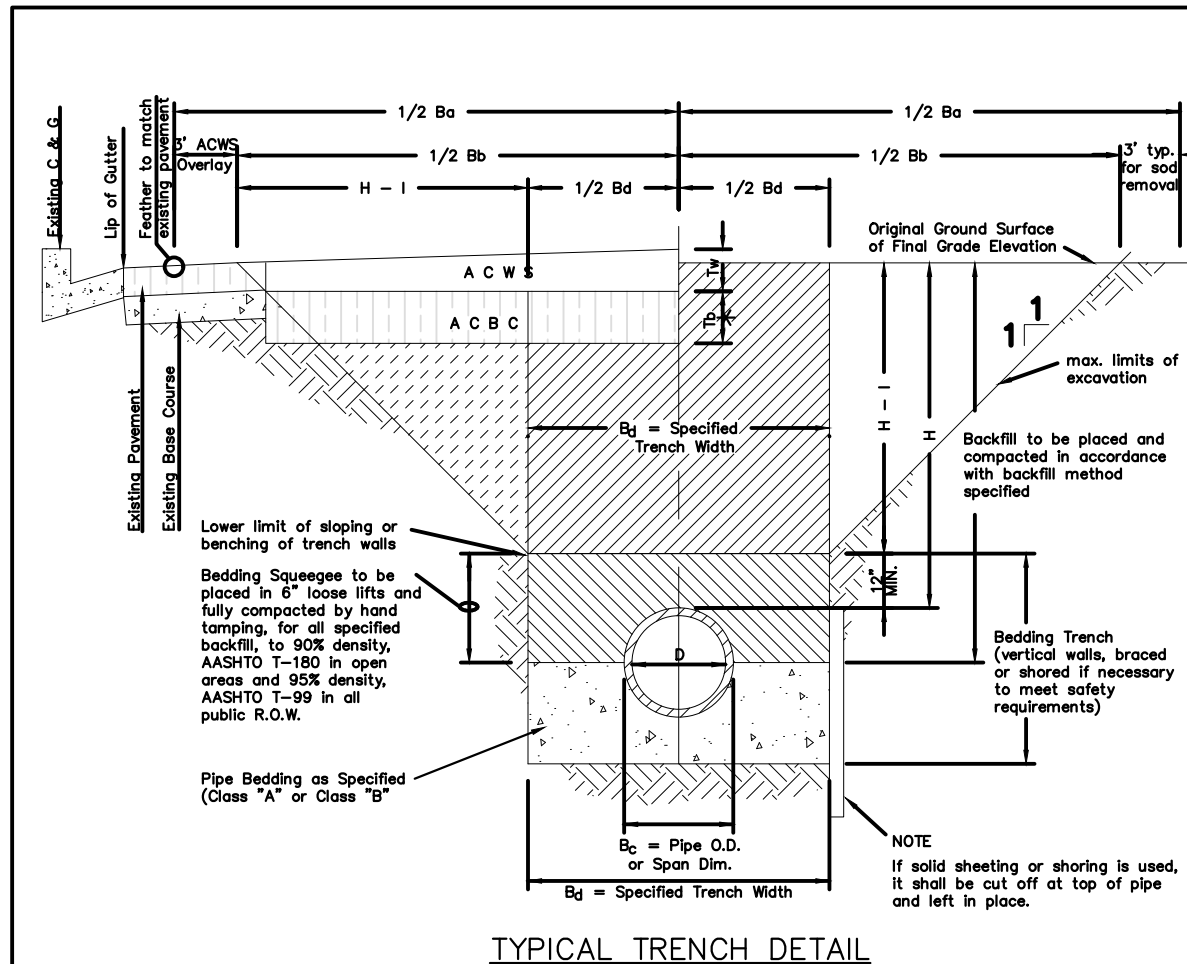

TYPICAL TRENCH DETAIL

**NOTES**

- Sloping or benching of trench side walls, where permitted shall be in accordance with applicable Federal, State and Local safety regulations.
- Trench shall be broad and shored as necessary to afford safe working conditions or to protect adjacent utilities, structures, etc. Unless otherwise specified on the plans, no pavement will be made for removal, replacement or relocation of curb and gutters, utilities, sidewalks, structures, etc. outside the maximum limits of excavation as shown and the contractor shall be responsible for protection of same.
- If dimension  $T_2$  is  $\leq 5'$ , then existing asphalt pavement shall be removed and replaced up to the gutter. Maximum asphalt pavement,  $R_2$  if  $R_2$  shall then be based upon this section only.

ASPHALT AND BASE COURSE REPLACEMENT SCHEDULE			
STREET WIDTH	ASPHALTIC BASE COURSE (A C B C)	ASPHALTIC WEARING SURFACE (A C W S)	TOTAL THICKNESS (T <sub>2</sub> )
UP TO 36'	4"	2"	6"
36' TO 44'	4"	3"	7"
44' TO 48'	5"	3"	8"
WIDER THAN 48'	6"	3"	9"

TABLE II \* Unless otherwise noted on the plans or in the specs.

STONEGATE VILLAGE METROPOLITAN DISTRICT  
SEWER TRENCHING AND BEDDING DETAIL

SCALE: NONE DATE: 4/00  
APPROVED: RJD DISTRICT ENGINEER

2000 REVISION SHEET 1

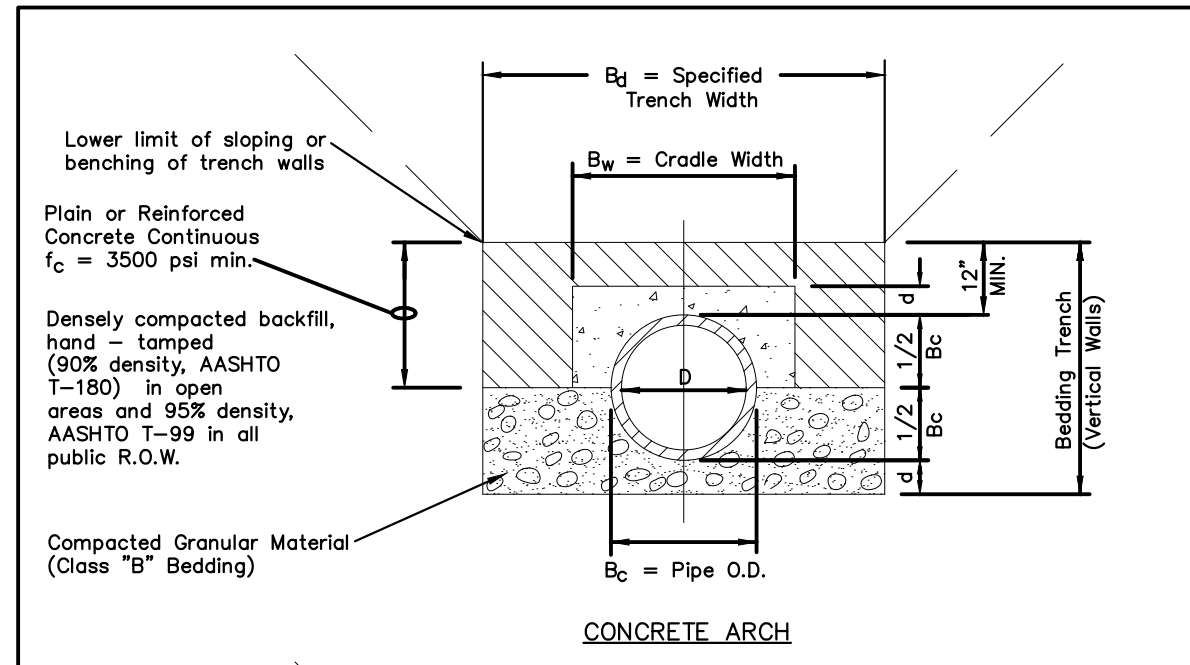

CONCRETE ARCH

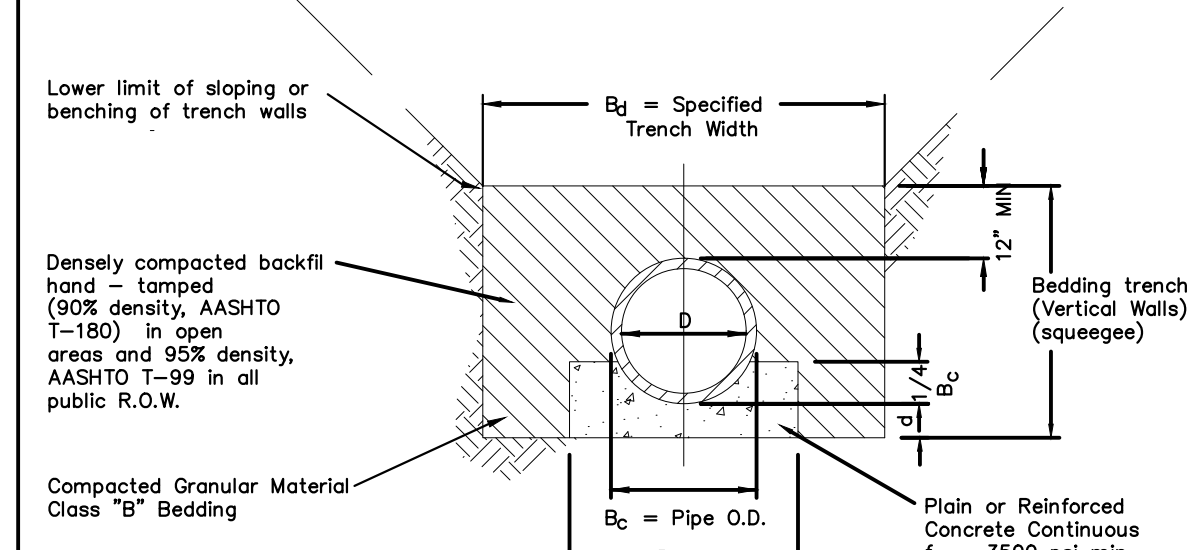

CONCRETE CRADLE

**NOTE:** The Design Engineer shall be responsible for structural design of the concrete cradle and/or concrete arch.

TABLE III		
NOMINAL DIAMETER (D)	MINIMUM THICKNESS (t)	MIN. WIDTH OF CRADLE (B <sub>w</sub> )
18" & smaller	4"	B <sub>c</sub> + 6"
21" to 24"	6"	B <sub>c</sub> + 8"
27" to 33"	8"	B <sub>c</sub> + 8"
36" to 42"	10"	1.25 B <sub>c</sub>
48" & larger	1/4 D	1.25 B <sub>c</sub>

STONEGATE VILLAGE METROPOLITAN DISTRICT  
TRENCHING AND BEDDING DETAIL - CLASS "A"

SCALE: NONE DATE: 4/00  
APPROVED: RJD DISTRICT ENGINEER

2000 REVISION SHEET 2

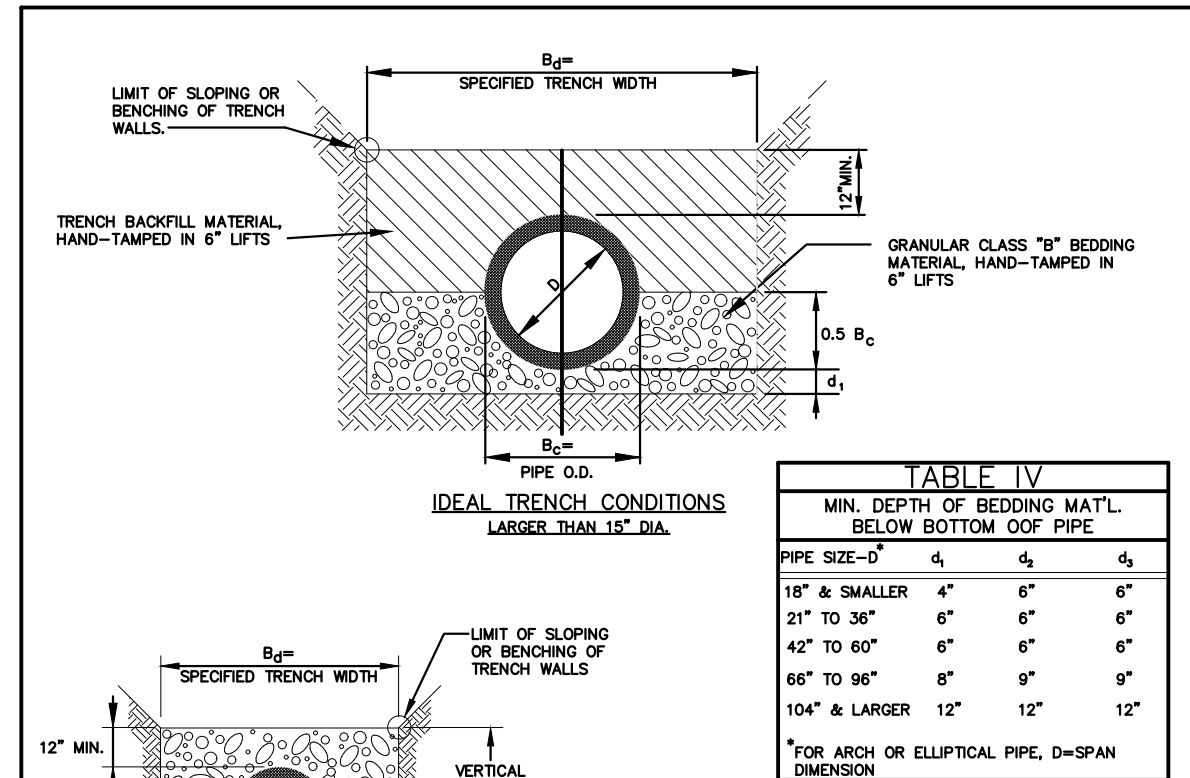

IDEAL TRENCH CONDITIONS

PIPE SIZE - D	4"	6"	8"
18" & SMALLER	4"	6"	6"
21" to 36"	6"	6"	6"
42" to 60"	6"	6"	6"
66" to 96"	6"	9"	9"
104" & LARGER	12"	12"	12"

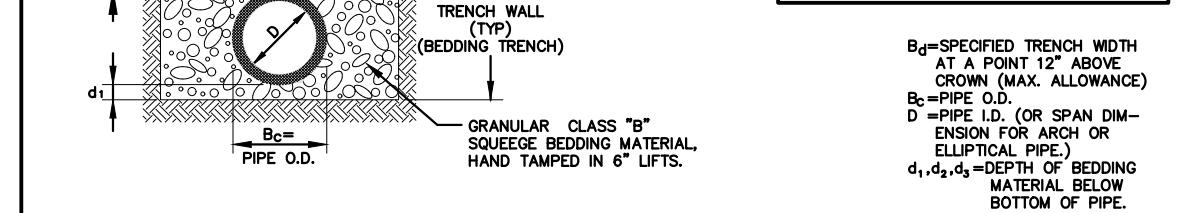

IDEAL TRENCH CONDITIONS

**GENERAL NOTES:**

- 1-1 THESE DETAILS ARE TYPICAL FOR NORMAL TRENCH CONDITIONS. FOR INSTALLATIONS OTHER THAN THESE (SUCH AS EMBANKMENT OR TUNNEL INSTALLATIONS, ETC.) EXCAVATION, BEDDING AND BACKFILL REQUIREMENTS SHALL BE DETAILED ON THE CONSTRUCTION DRAWINGS. FOR UNUSUAL OR UNSTABLE SOIL CONDITIONS, TRENCH AND BEDDING DETAILS SHALL BE A SPECIAL DESIGN.
- 2-2 ULTIMATE BACKFILL LOADS AND STRUCTURAL DESIGN OF PIPE OR CONDUIT SHALL BE BASED UPON B<sub>2</sub> & TRANSITION WIDTH AS SET FORTH IN "REFERENCE R-2" (SEE BLOCK BELOW).
- 3-3 FOR INSTALLATIONS OTHER THAN TYPICAL TRENCH CONDITIONS, EXCAVATIONS, BEDDING, BACKFILL AND STRUCTURAL REQUIREMENTS SHALL BE DESIGNED IN ACCORDANCE WITH THE REFERENCES NOTED BELOW OR THE PIPE MFG.'S RECOMMENDATIONS.

STONEGATE VILLAGE METROPOLITAN DISTRICT  
TRENCHING AND BEDDING DETAIL - CLASS "B"

SCALE: NONE DATE: 4/00  
APPROVED: RJD DISTRICT ENGINEER

2000 REVISION SHEET 3

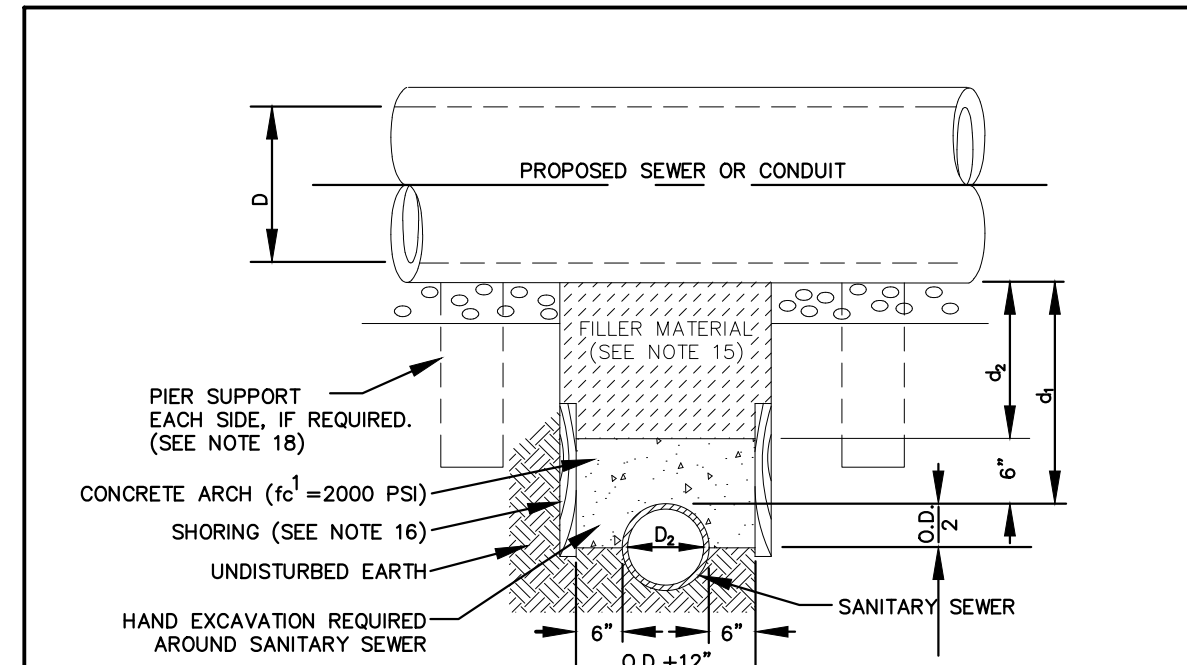

TYPE I CONCRETE ENCASEMENT FOR SANITARY SEWERS

(CONCRETE ARCH)

**GENERAL NOTES FOR TYPE I & II ENCASEMENT**

- CONCRETE TO BE CAST AGAINST UNDISTURBED SOIL OR SHORING. IF OPTIONAL CONSTRUCTION JOINT IS USED & BOTTOM HALF OF ENCASEMENT IS POURED SEPARATELY, A ONE INCH LAYER OF SAND OR MORTAR SHALL BE PLACED BETWEEN BOTTOM OF SANITARY SEWER AND TOP OF CONCRETE.
- LENGTH OF ENCASEMENT FOR: (a) TYPE I & II ENCASEMENT SHALL EXTEND FULL TRENCH WIDTH EXCAVATED FOR PROPOSED SEWER OR CONDUIT. (b) TYPE I ENCASEMENT SHALL EXTEND AT LEAST TO FEET EACH SIDE OF WATER MAIN.
- UNLESS OTHERWISE NOTED ON PLAN/PROFILE DRAWINGS, TYPE I & II ENCASEMENTS NEED NOT BE REINFORCED. REINFORCEMENT, IF REQUIRED, SHALL BE SPECIFIED AND DETAILED SEPARATELY ON PLAN & PROFILE DRAWINGS.
- TYPE I OR II ENCASEMENTS ARE REQUIRED UNDER FOLLOWING CONDITIONS: (a) TYPE I OR TYPE II IF  $d \leq 18"$  ( $d \leq 12"$  EXCEPT FOR SANITARY SEWER CROSSING OVER OR UNDER WATER MAINS). (b) TYPE II IS REQUIRED FOR SANITARY SEWERS CROSSING OVER TOP OF WATER MAINS, REGARDLESS OF DIMENSION "d". (c) EXCEPT FOR UNUSUAL CIRCUMSTANCES, WATER MAIN CROSSINGS, OR WHERE UNSTABLE SOIL CONDITIONS ARE ENCOUNTERED, TYPE I ENCASEMENT WILL NORMALLY BE SATISFACTORY. (d) IF THE SANITARY SEWER IS REPLACED OR CONSTRUCTED OF DUCTILE IRON PIPE (AWWA C-150 OR C-151), CONCRETE ENCASEMENT MAY NOT BE REQUIRED.
- FILLER MATERIAL BETWEEN CONDUITS TO BE: (a) APPROVED COMPRESSIBLE MATERIAL SUCH AS STYROFOAM, ETC. IF  $d_1 \leq 4"$  &  $d_2 \leq 6"$ . (b) COMPACTED CLASS "B" BEDDING IF  $d_1 \leq 4"$  &  $d_2 > 6"$  (IF  $d_1 > 6"$  FOR TYPE II ENCASEMENT POUR CONCRETE ON UNDISTURBED SOIL).
- SHORING OR SHEETING, IF USED, TO BE CUT OFF AT TOP OF ENCASEMENT.
- THESE ENCASEMENT DETAILS MAY ALSO BE APPLICABLE FOR CONDUITS OTHER THAN STORM OR SANITARY SEWER INSTALLATIONS.
- IN CERTAIN SITUATIONS WHERE CONDUIT DIAMETER "D" IS EXTREMELY LARGE, PIER SUPPORTS ON EACH SIDE OF SANITARY SEWER MAY ALSO BE REQUIRED. IF REQUIRED, SUPPORTS SHALL BE SPECIFIED AND DETAILED SEPARATELY ON PLAN AND PROFILE DRAWINGS.

2000 REVISION SHEET 4

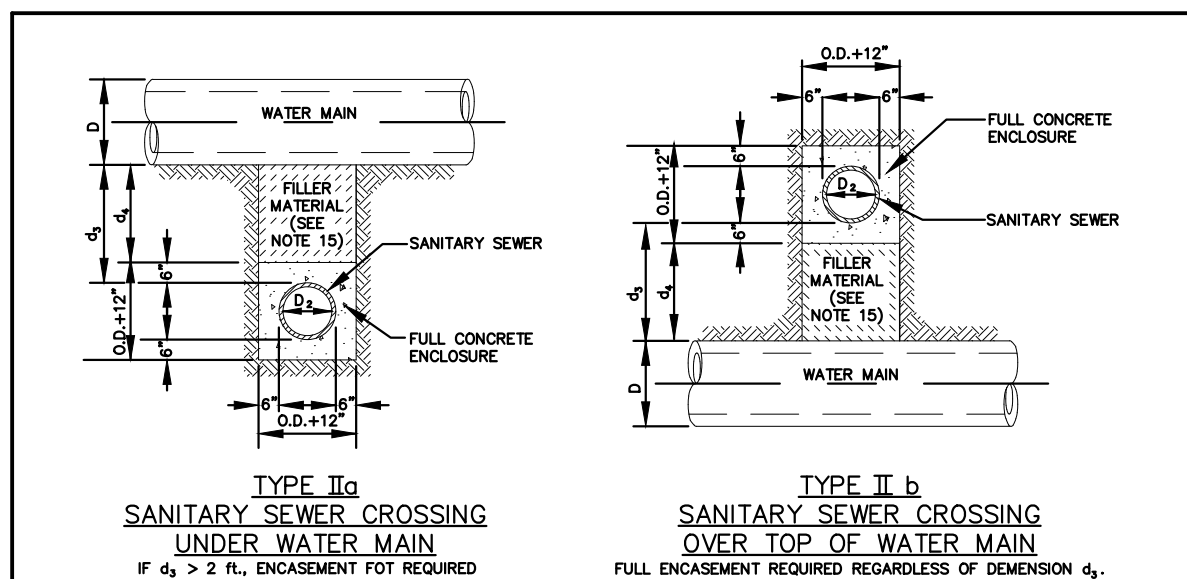

TYPE IIa SANITARY SEWER CROSSING UNDER WATER MAIN

IF  $d_1 \leq 4'$ , ENCASEMENT FOR REQUIRED

FULL ENCASEMENT REQUIRED REGARDLESS OF DIMENSION  $d_2$ .

TYPE IIb Sanitary Sewer Crossing Over Water Main diagram showing cross-section with labels: WATER MAIN, FULL CONCRETE ENCLOSURE, SANITARY SEWER, FILLER MATERIAL, and O.D. + 12".

TYPE IIb SANITARY SEWER CROSSING OVER WATER MAIN

FULL ENCASEMENT REQUIRED REGARDLESS OF DIMENSION  $d_2$ .

STONEGATE VILLAGE METROPOLITAN DISTRICT  
CONCRETE ENCASEMENT TYPE II

SCALE: NONE DATE: 4/00  
APPROVED: RJD DISTRICT ENGINEER

2000 REVISION SHEET 5

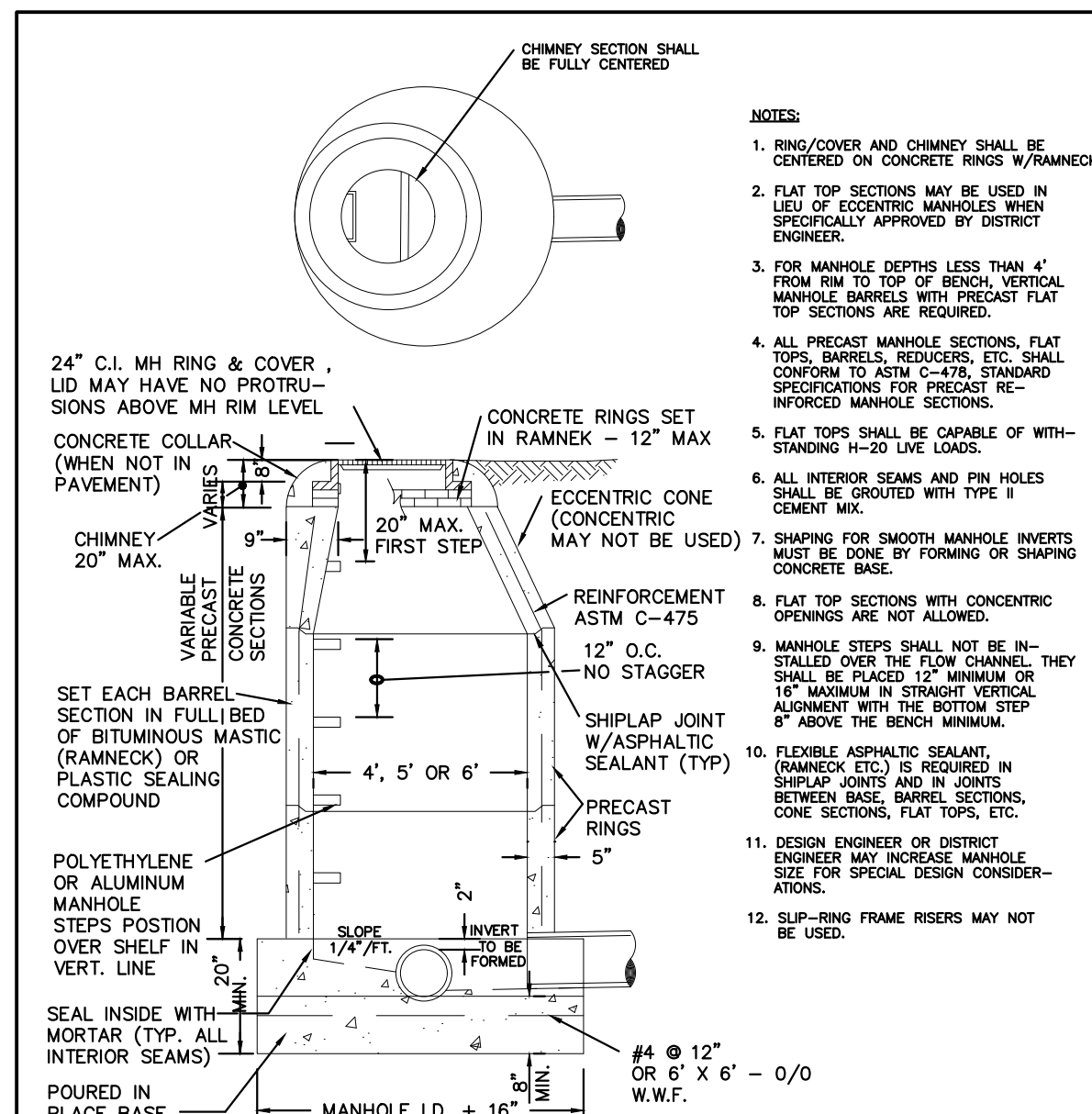

STONEGATE VILLAGE METROPOLITAN DISTRICT  
PRECAST MANHOLE ECCENTRIC CONE

SCALE: NONE DATE: 4/00  
APPROVED: RJD DISTRICT ENGINEER

2000 REVISION SHEET 6

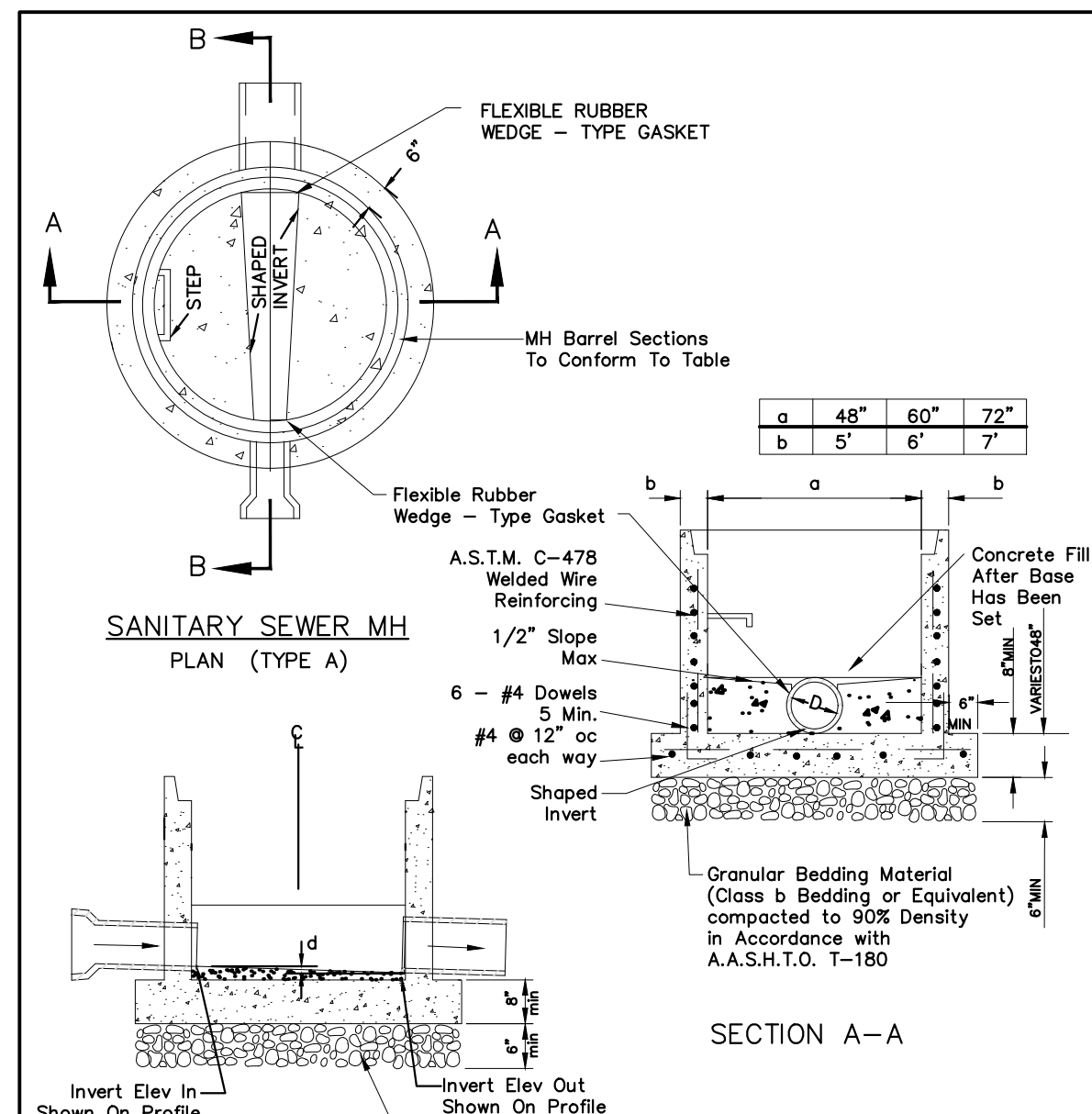

STONEGATE VILLAGE METROPOLITAN DISTRICT  
PRECAST MANHOLE BASE DETAIL

SCALE: NONE DATE: 4/00  
APPROVED: RJD DISTRICT ENGINEER

2000 REVISION SHEET 7

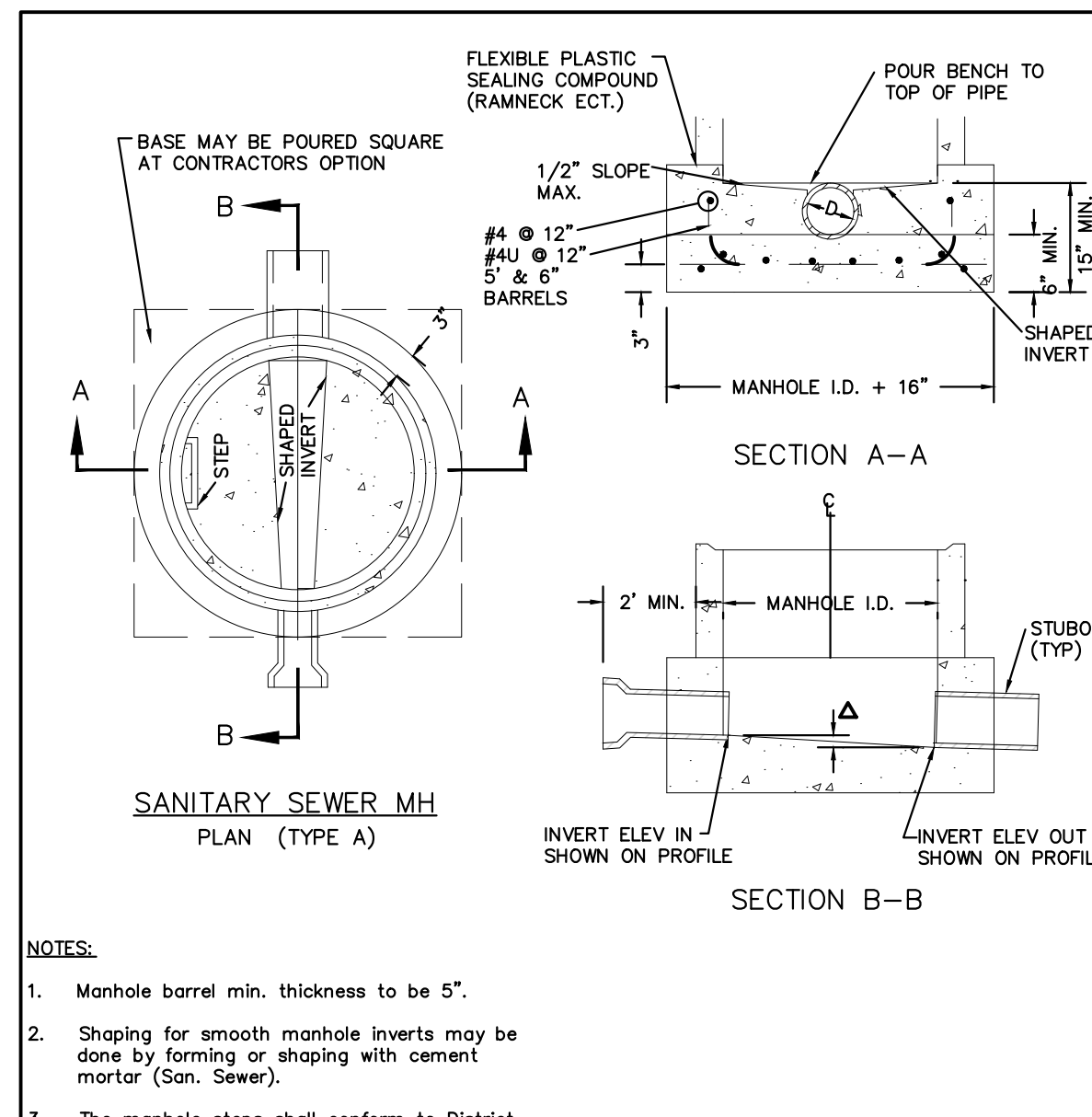

STONEGATE VILLAGE METROPOLITAN DISTRICT  
CAST-IN-PLACE MANHOLE BASE DETAIL

SCALE: NONE DATE: 4/00  
APPROVED: RJD DISTRICT ENGINEER

2000 REVISION SHEET 8

NO.	ISSUED FOR CONSTRUCTION	DATE	CHANGED (CHKD) (APPR)
0	ISSUED FOR CONSTRUCTION	7/19/2024	



THE USE OF THESE DRAWINGS IS AN ACKNOWLEDGMENT OF THE SERVICE PROVIDED BY MERRICK AND COMPANY, INC. A SERVICE PROJECT, REUSE OR MODIFICATION OF ANY DRAWING IS NOT A PROHIBITED INSTRUMENT, WITHOUT THE WRITTEN CONSENT OF MERRICK AND COMPANY. ANY CHANGES TO THESE DRAWINGS SHALL BE THE SOLE RESPONSIBILITY OF THE USER. MERRICK AND COMPANY IS NOT RESPONSIBLE FOR ANY CHANGES TO THESE DRAWINGS.

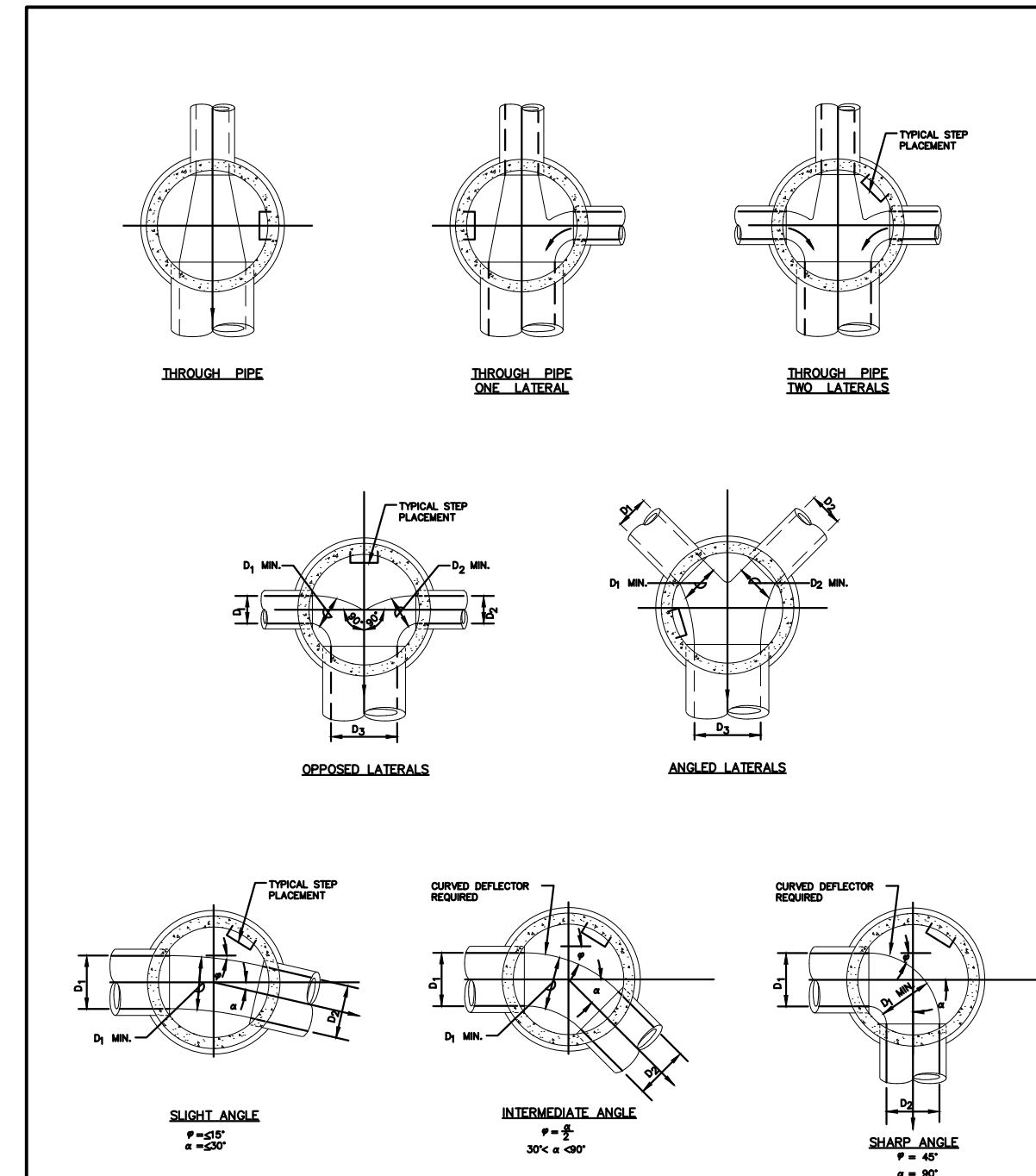

STONEGATE VILLAGE METROPOLITAN DISTRICT	
TYPICAL BASE CHANNELIZATION DETAILS	
SCALE: NONE	DATE: 4/00
APPROVED: RJD	DISTRICT ENGINEER

2000 REVISION SHEET 15

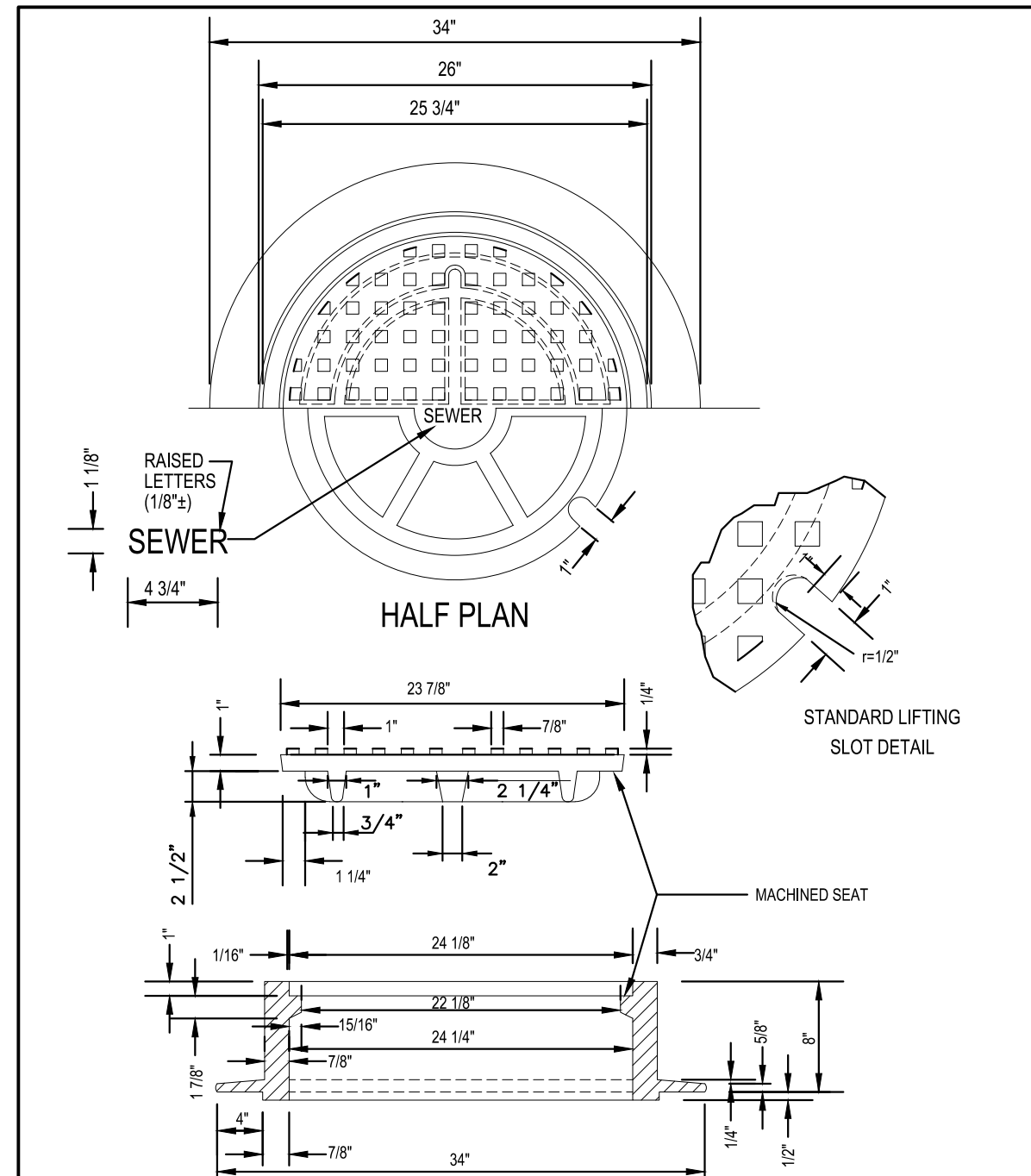

STONEGATE VILLAGE METROPOLITAN DISTRICT	
24" DIAMETER RING AND COVER	
SCALE: NONE	DATE: 4/00
APPROVED: RJD	DISTRICT ENGINEER

2000 REVISION SHEET 17

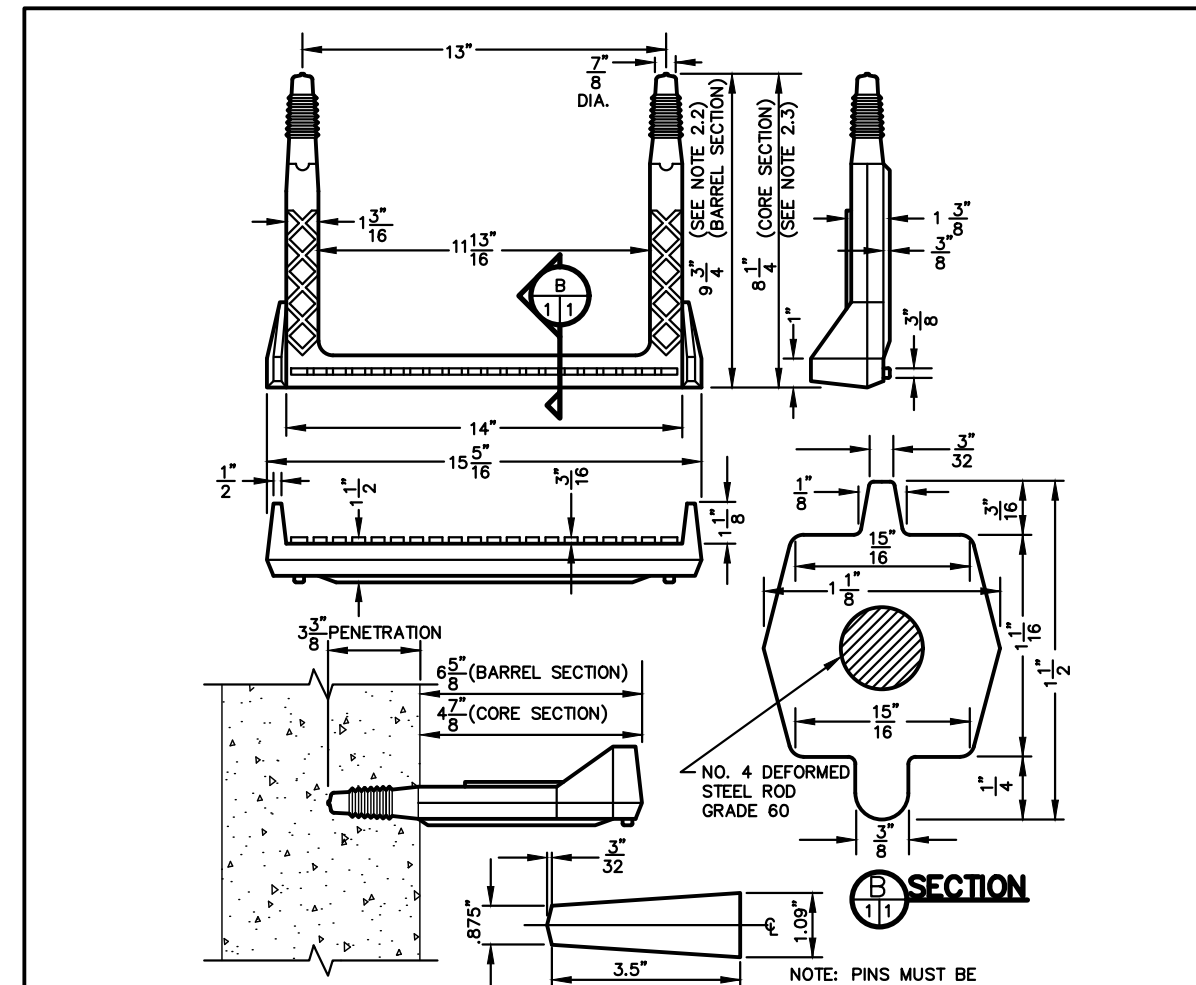

- NOTES:
- ASTM SPECIFICATIONS:
    - ASTM C-478
    - ASTM A-815 GRADE 60 (STEEL ROD)
    - ASTM 2146-69, TYPE II, GRADE 16906 (POLYPROPYLENE)
  - STEPS INSTALLED IN MANHOLE BARREL SECTIONS OR VERTICAL WALLS OF STRUCTURE SHALL HAVE A 9-3/4 INCH LEG AND SHALL PROJECT FROM THE WALL 6-5/8 INCHES AND SHALL PROJECT FROM THE WALL 4-7/8 INCHES.
  - ALL STEPS SHALL HAVE A PENETRATION DEPTH INTO THE WALL OF 3-3/8 INCHES.
  - STEPS SHALL BE INSTALLED BY THE "PRESS-FIT" METHOD UTILIZING A SPECIALLY TAPERED PIN TO FORM THE INSERT HOLE AS SHOWN.
  - INSTALLED STEPS SHALL BE CAPABLE OF WITHSTANDING A PULL OUT FORCE OF 2500 P.S.I. PER LEG FOR A MINIMUM PERIOD OF TWO MINUTES.
  - STEPS SHALL BE INSTALLED BY THE "PRESS-FIT" METHOD EXCLUSIVELY FOLLOWING MANUFACTURER'S RECOMMENDED PROCEDURE AND SHALL NOT BE GROUTED IN PLACE.

STONEGATE VILLAGE METROPOLITAN DISTRICT	
POLYPROPYLENE REINFORCED PLASTIC MANHOLE STEP	
SCALE: NONE	DATE: 4/00
APPROVED: RJD	DISTRICT ENGINEER

2000 REVISION SHEET 20

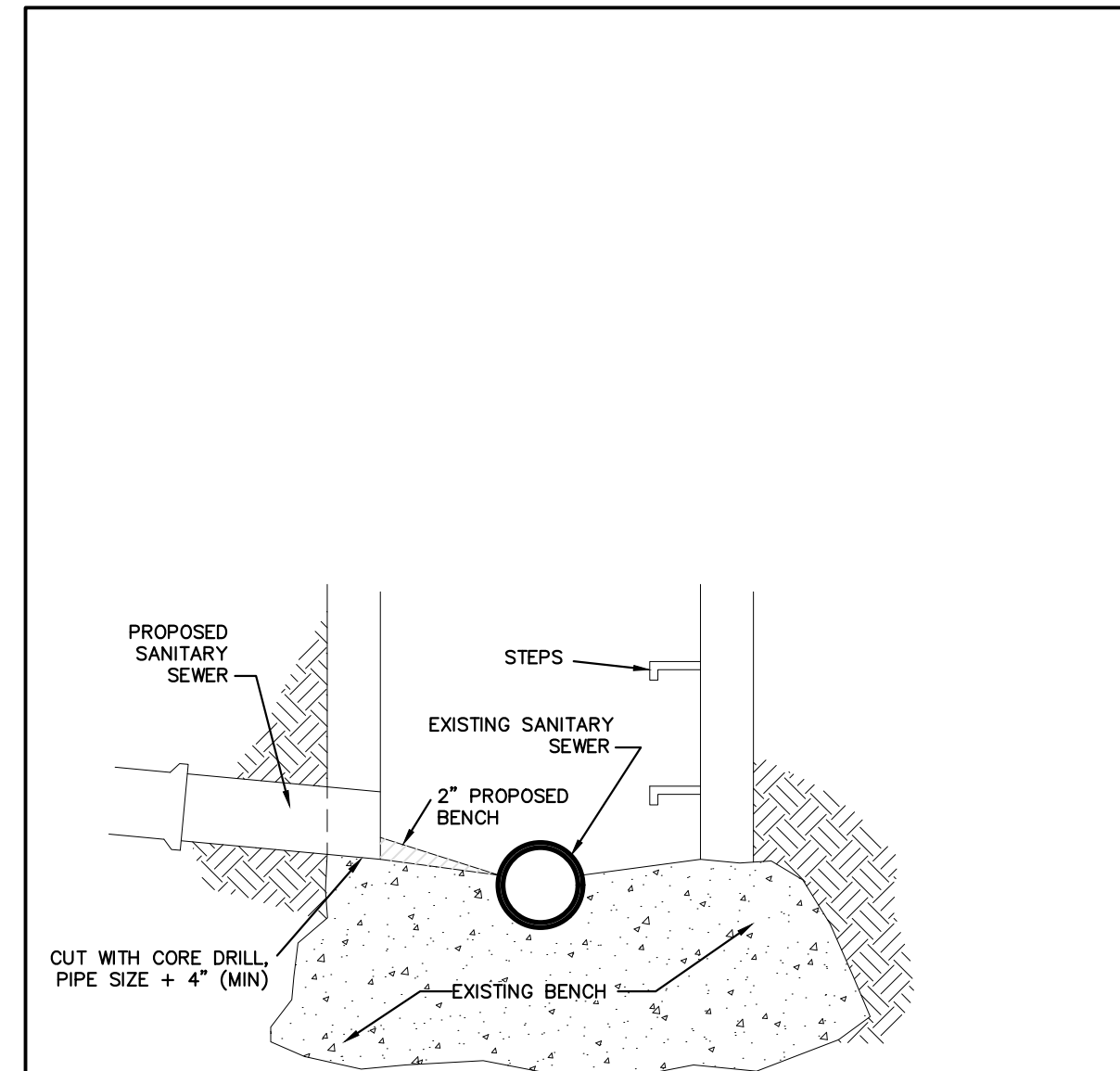

STONEGATE VILLAGE METROPOLITAN DISTRICT	
MANHOLE INVERT TIE-IN DETAIL	
SCALE: NONE	DATE: 4/00
APPROVED: RJD	DISTRICT ENGINEER

2000 REVISION SHEET 22

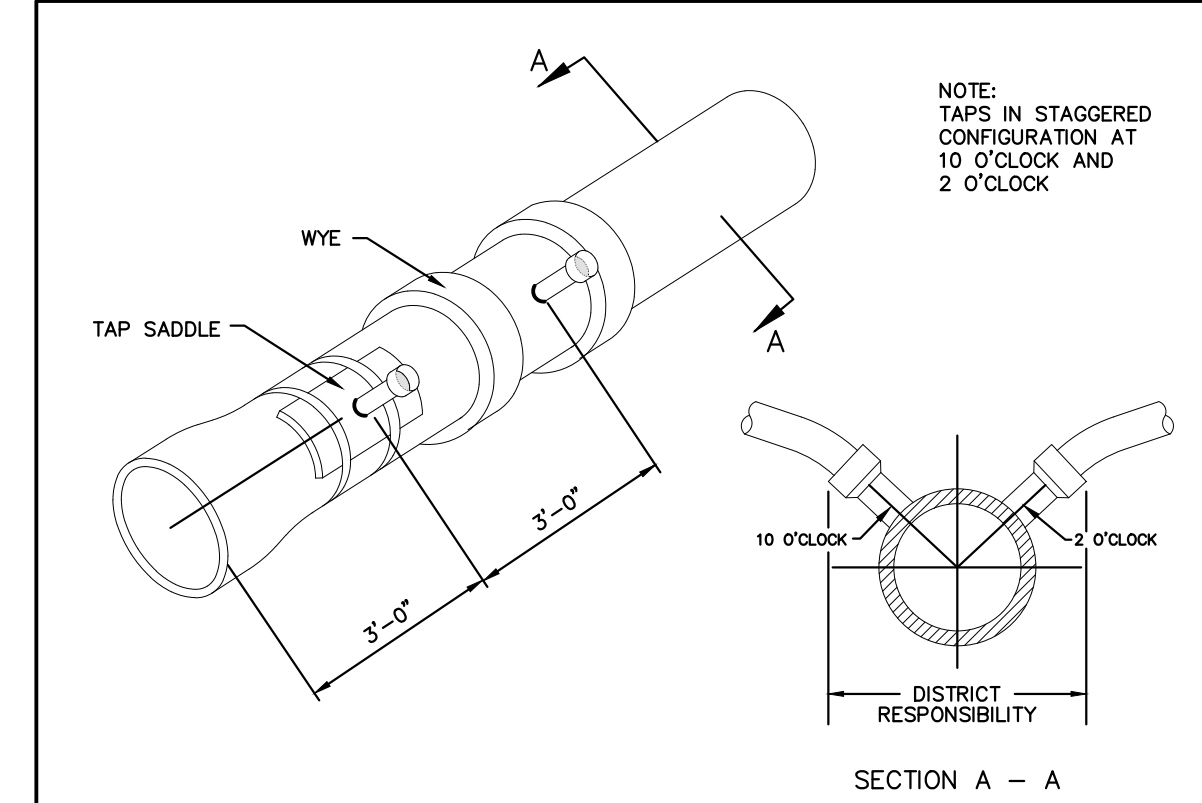

NOTE: TAPS IN STAGGERED CONFIGURATION AT 10 O'CLOCK AND 2 O'CLOCK

SECTION A - A

DOMESTIC SEWER TAPPING DETAIL

STONEGATE VILLAGE METROPOLITAN DISTRICT	
DOMESTIC SEWER TAPPING DETAIL	
SCALE: NONE	DATE: 4/00
APPROVED: RJD	DISTRICT ENGINEER

2000 REVISION SHEET 27

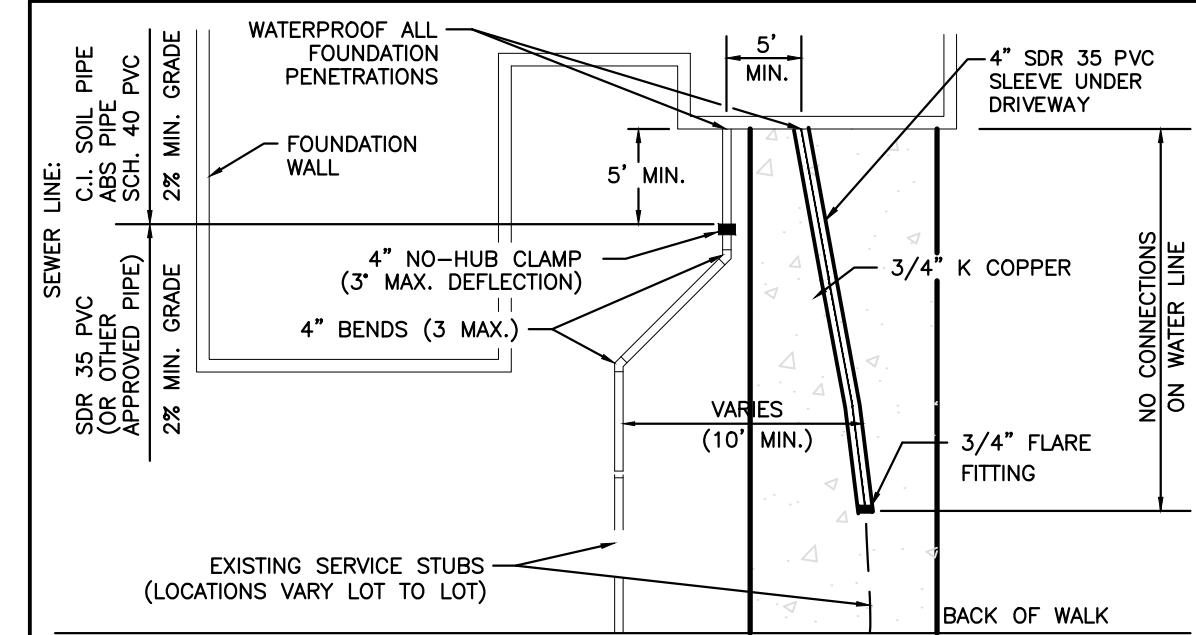

TYPICAL SERVICES PLAN VIEW NTS

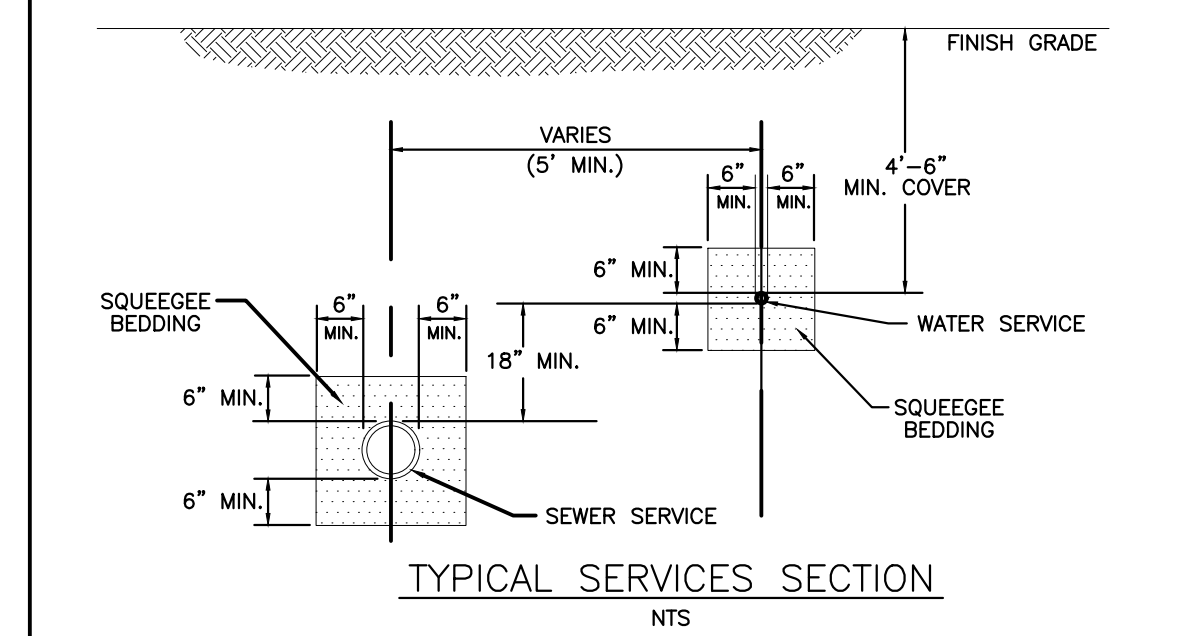

TYPICAL SERVICES SECTION NTS

NOTE: SEE SHEET 28 FOR DISTRICT POLICIES AND INSTALLATION NOTES.

STONEGATE VILLAGE METROPOLITAN DISTRICT	
TYPICAL SEWER SERVICES	
SCALE: NONE	DATE: 4/00
APPROVED: RJD	DISTRICT ENGINEER

2000 REVISION SHEET 28

- INSPECTION POLICY:
- ALL SERVICE INSPECTIONS MUST BE SCHEDULED WITH THE DISTRICT ENGINEER'S OFFICE (303) 263-3699 AT LEAST 24 HOURS IN ADVANCE OF THE REQUESTED INSPECTION.
  - SERVICE INSPECTIONS WILL OCCUR BETWEEN 1:00 P.M. AND 4:00 P.M. SPECIFIC INSPECTION TIMES ARE NOT AVAILABLE.
  - IF THE CONTRACTOR IS NOT READY FOR INSPECTION WHEN THE INSPECTOR ARRIVES AT THE SITE, A RE-INSPECTION WILL HAVE TO BE SCHEDULED IN ACCORDANCE WITH NOTES 1 AND 2 ABOVE.
  - SHOULD THE SERVICE LINES BE DAMAGED BY LATER CONSTRUCTION, AN INSPECTION OF THE REPAIR WILL BE REQUIRED IN ACCORDANCE WITH NOTES 1 AND 2 ABOVE.
  - THE CONTRACTOR SHALL LEAVE ALL PIPE AND FITTINGS EXPOSED FOR THE INSPECTOR TO OBSERVE. INSPECTORS WILL NOT ENTER ANY EXCAVATIONS TO CHECK MATERIALS. THE TOP LAYER OF BEDDING CAN BE ADDED AFTER THE INSPECTION HAS BEEN COMPLETED.
  - ALL EXCAVATIONS SHALL BE IN ACCORDANCE WITH OSHA STANDARDS.

- INSTALLATION NOTES:
- SEWER
- ACCEPTABLE PIPE MATERIALS ARE TO BE SDR 35 PVC PIPE, ABS PIPE AND CAST IRON CLASS 22 SOIL PIPE. APPROVED BEDDING IS TO BE SQUEEGEE.
  - NO-HUB CLAMPS SHALL BE USED TO JOIN 2 MALE PIPE ENDS WITH A MAXIMUM DEFLECTION OF 3".
  - MINIMUM GRADE SHALL BE 2%.
  - INSTALLATION SHALL INCLUDE NO MORE THAN 3 BENDS. 90° BENDS ARE NOT ALLOWED. SOLVENT WELDED PIPE WILL NOT BE ALLOWED.
  - CLEAN-OUTS SHALL BE INSTALLED AT 100' INTERVALS. CLEAN-OUTS ARE NOT REQUIRED FOR SERVICES LESS THAN 100'.
  - STRESSING OF THE PIPE BETWEEN FITTINGS WILL NOT BE ALLOWED.

STONEGATE VILLAGE METROPOLITAN DISTRICT	
DISTRICT POLICIES & INSTALLATION NOTES FOR SEWER SERVICES	
SCALE: NONE	DATE: 4/00
APPROVED: RJD	DISTRICT ENGINEER

2000 REVISION SHEET 29

ISSUED FOR CONSTRUCTION	7/19/2024	DATE	CHND/CHKD/APPR
REV/REVISION DESCRIPTION			

